

THIS DRAWING IS UNPUBLISHED. RELEASED FOR PUBLICATION
 © COPYRIGHT - By - ALL RIGHTS RESERVED.

LOC		DIST		REVISIONS			
P	LTR	DESCRIPTION		DATE	DWN	APVD	
GP	00	M		REVISED PER ECO-12-021105	27DEC2012	CJV	SLB

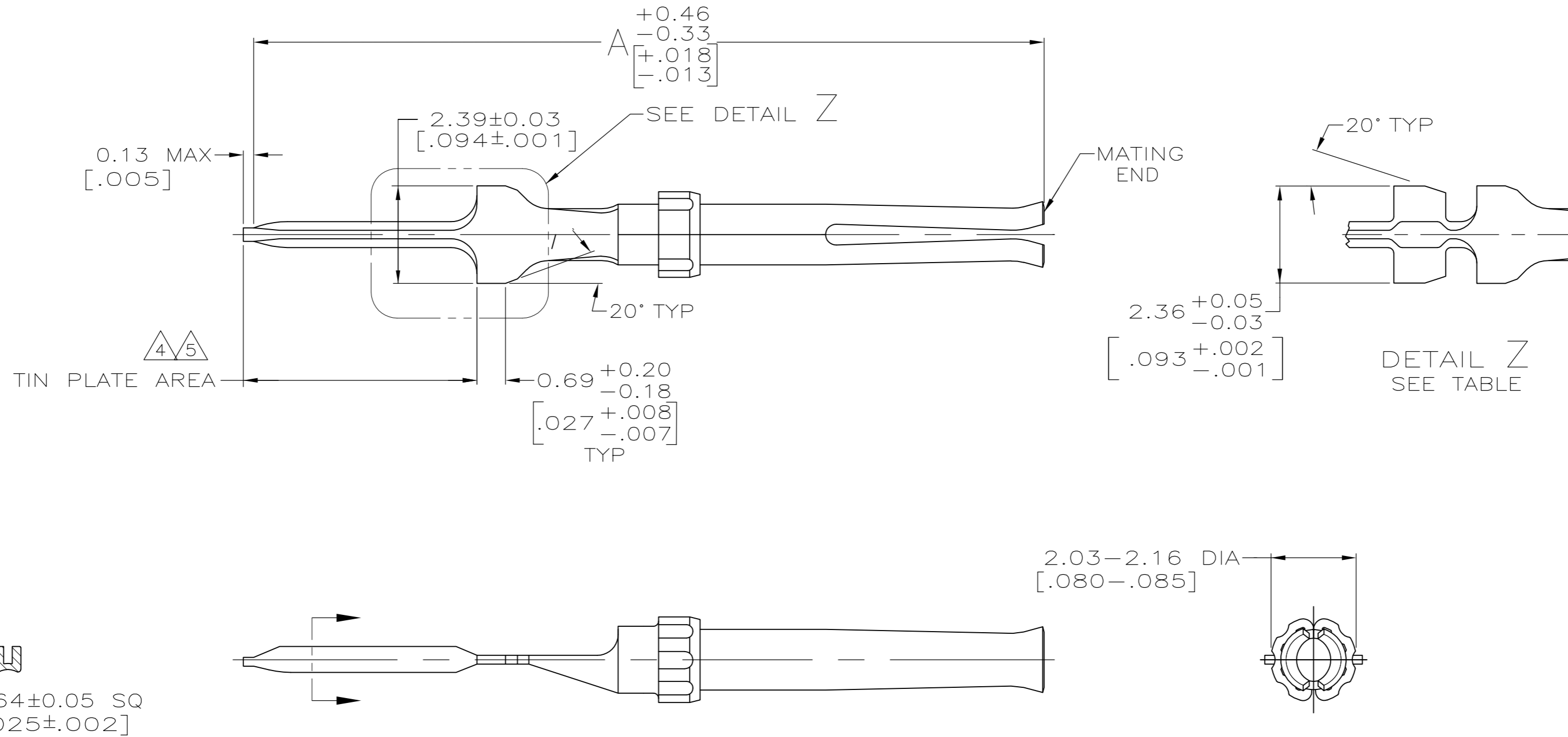

- FOR MATING CONTACT SEE DRAWING 745287.
- TO BE USED FOR REPLACEMENT ONLY.
- PLATED GOLD FLASH FOR LENGTH OF 2.54 [.100] MIN FROM MATING END, 2.54µm [.000100] MIN TIN ON TIN PLATE AREA, ALL OVER 1.27µm [.000050] MIN NICKEL.
- PLATED GOLD FLASH FOR LENGTH OF 2.54 [.100] MIN FROM MATING END 2.54µm [.000100] MIN TIN-LEAD ON TIN PLATE AREA, ALL OVER 1.27µm [.000050] MIN NICKEL.
- PLATED 0.76µm [.000030] GOLD FOR LENGTH OF 2.54 [.100] MIN FROM MATING END, 2.54µm [.000100] MIN TIN-LEAD ON TIN PLATE AREA, ALL OVER 1.27µm [.000050] MIN NICKEL.
- GOLD PLATED AS FOLLOWS:
 PLATED WITH 0.76µm [.000030] GOLD FOR A LENGTH OF 2.54 [.100] MIN FROM MATING END, 2.54µm [.000100] MIN TIN ON TIN PLATE AREA, ALL OVER 1.27µm [.000050] MIN NICKEL.
 OR
 GOLD FLASH OVER PALLADIUM-NICKEL PLATE, 0.76µm [.000030] MIN TOTAL FOR A LENGTH OF 2.54 [.100] MIN FROM MATING END, 2.54µm [.000100] MIN TIN ON TIN PLATE AREA, ALL OVER 1.27µm [.000050] MIN NICKEL.
- MATERIAL: PHOSPHOR BRONZE.

	PER DETAIL Z	26.92 [1.060]	3	7-745288-2
OBSOLETE	AS SHOWN	30.15 [1.187]	6	7-745288-0
	PER DETAIL Z	32.56 [1.282]	6	6-745288-1
	PER DETAIL Z	26.92 [1.060]	6	5-745288-8
	AS SHOWN	19.30 [.760]	6	5-745288-5
OBSOLETE	AS SHOWN	30.15 [1.187]	5	4-745288-4
OBSOLETE	AS SHOWN	21.16 [.833]	5	2-745288-0
OBSOLETE	AS SHOWN	21.16 [.833]	4	1-745288-8
OBSOLETE	PER DETAIL Z	32.56 [1.282]	5	1-745288-2
OBSOLETE	PER DETAIL Z	32.56 [1.282]	4	1-745288-0
OBSOLETE	PER DETAIL Z	26.92 [1.060]	5	745288-8
OBSOLETE	PER DETAIL Z	26.92 [1.060]	4	745288-6
OBSOLETE	AS SHOWN	19.30 [.760]	5	745288-4
OBSOLETE	AS SHOWN	19.30 [.760]	4	745288-2
	RETENTION TINES	A	FINISH	PART NO

THIS DRAWING IS A CONTROLLED DOCUMENT. DIMENSIONING AND TOLERANCING PER ASME Y14.5M-2009

DWN: R.SHIREY 29 JAN 91
 CHK: J.MCCLINTON 06 FEB 91

TE Connectivity

SOCKET CONTACT, SIZE 20 DF, AMPLIMITE

SIZE: A2 CAGE CODE: 00779 C=745288

SCALE: 10:1 SHEET: 1 OF 1 REV: M

CUSTOMER DRAWING

X-ON Electronics

Largest Supplier of Electrical and Electronic Components

Click to view similar products for [D-Sub Contacts](#) category:

Click to view products by [TE Connectivity](#) manufacturer:

Other Similar products are found below :

[173112-0723](#) [173112-0393](#) [173112-0389](#) [173112-0750](#) [173112-0912](#) [D02-22-22P-10000](#) [D02-22-26S-10000](#) [FMP009P104](#) [FMP010P104](#)
[FMP010S104](#) [FMP016P104](#) [FMP051S110](#) [FMX006S128B](#) [131A11039X](#) [131J21029X](#) [132J22039X](#) [132A11029X](#) [132A11049X](#)
[132C12029X](#) [RMPIR01S02E2RLF](#) [DM53744-1](#) [1757912-1](#) [188582-000](#) [162A11839X](#) [162A11889X](#) [1757913-1](#) [FMP006S110](#)
[FMP008P104](#) [FMP009S104](#) [FMP139S115](#) [212558-1](#) [D02-22-26P-10000](#) [L17DM53744217](#) [030-1955-000](#) [030-50634](#) [053744-0098](#)
[601064N004](#) [601098N003](#) [6-745288-2](#) [D-610-10CS2962](#) [86303057NLF](#) [DM537425001NCLF](#) [173112-0045](#) [162A11819X](#) [1731120397](#) [40-](#)
[9854MP](#) [1-208778-5](#) [1-745288-3](#) [173112-0455](#) [121A05329A](#)