

REVISIONS				
P	LTN	DESCRIPTION	DATE	APVD
D15		REVISED PER ECO-20-004256	25MAR2020	JM DS
D16		REVISED PER PCN E-20-016603	24NOV2020	PN DS
E		REVISED PER ECN-21-123056	08NOV2021	DK CB

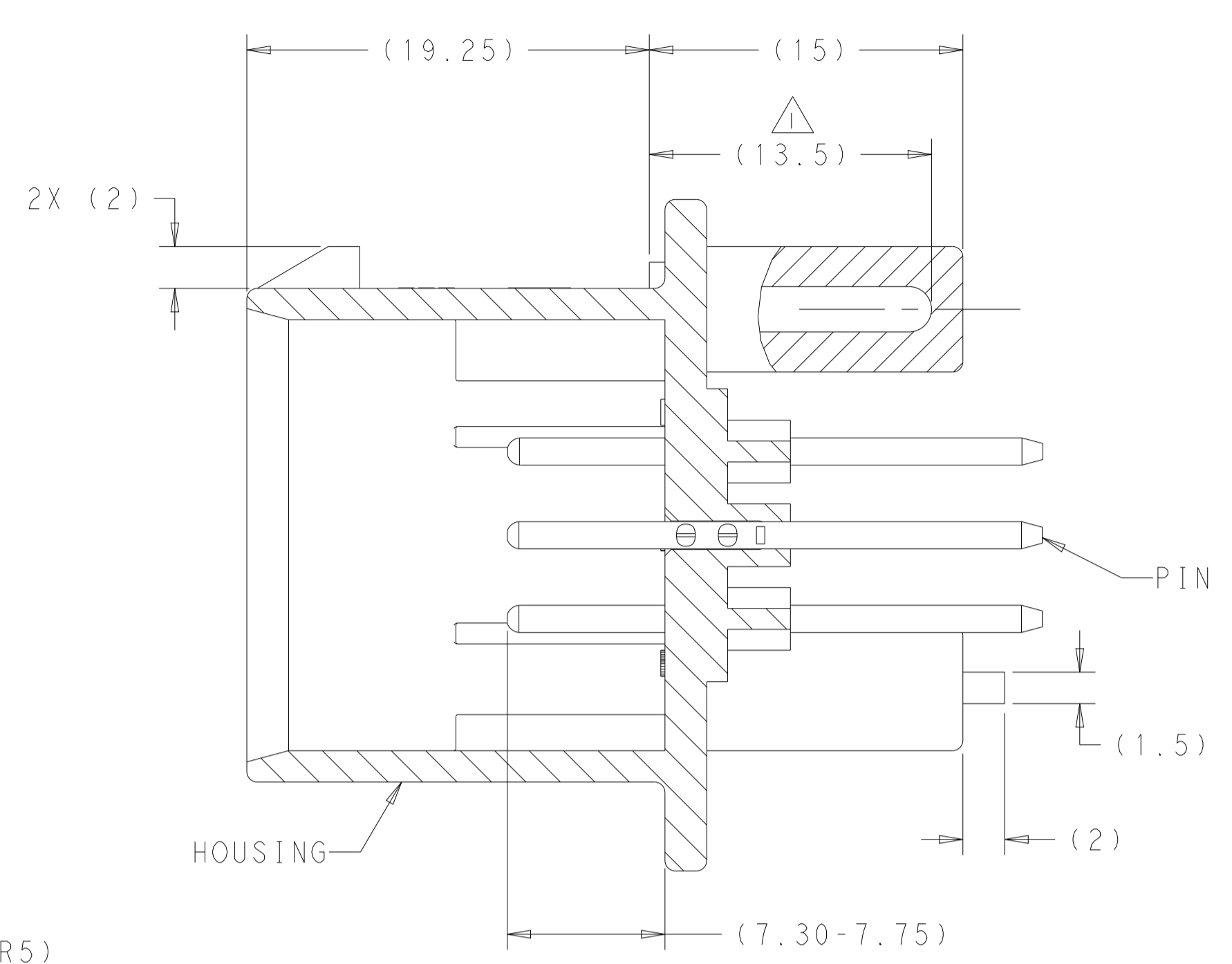

SECTION A-A

- 1 SUGGESTED MOUNTING SCREW SIZE IS $\varnothing 2.50-3.00\text{mm}$ [$\varnothing 0.099 - 0.118$ INCH] SELF TAPPING THREAD FORMING SCREW, SUCH AS DELTA PT, TO BE DRIVEN AT 0.6-0.8 N-m. THE CUSTOMER SHOULD TEST THE SCREW SIZE AND TYPE IN ORDER TO VERIFY THEIR SELECTION FOR THEIR APPLICATION.
- 2 DATE CODE IN THIS LOCATION USING 5 DIGIT CODE. FIRST 2 DIGITS = YEAR, SECOND 2 DIGITS = WEEK, LAST DIGIT = DAY.
- 3 MATERIALS: HEADER HOUSING - GLASS FILLED PBT; PINS - TIN OR GOLD PLATED BRASS.
- 4 HOUSING COLORS ARE MECHANICALLY KEYED TO MATE ONLY WITH IDENTICALLY COLORED PLUG ASSEMBLIES.
- 5. HEADER MATES TO PLUG ASSEMBLY 770680 WHICH USES REELED TERMINAL 770520 OR LOOSE PIECE TERMINAL 770854.

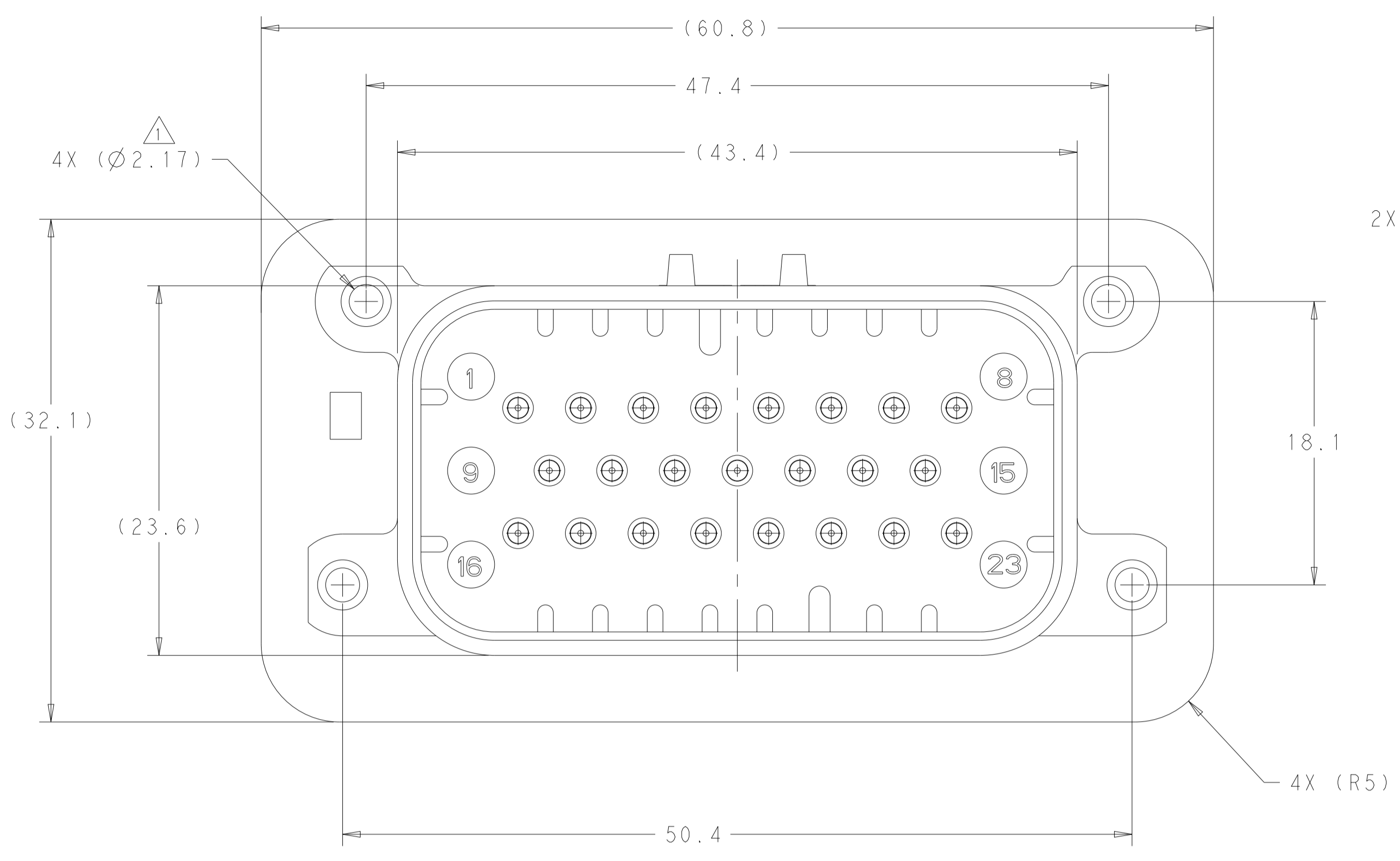
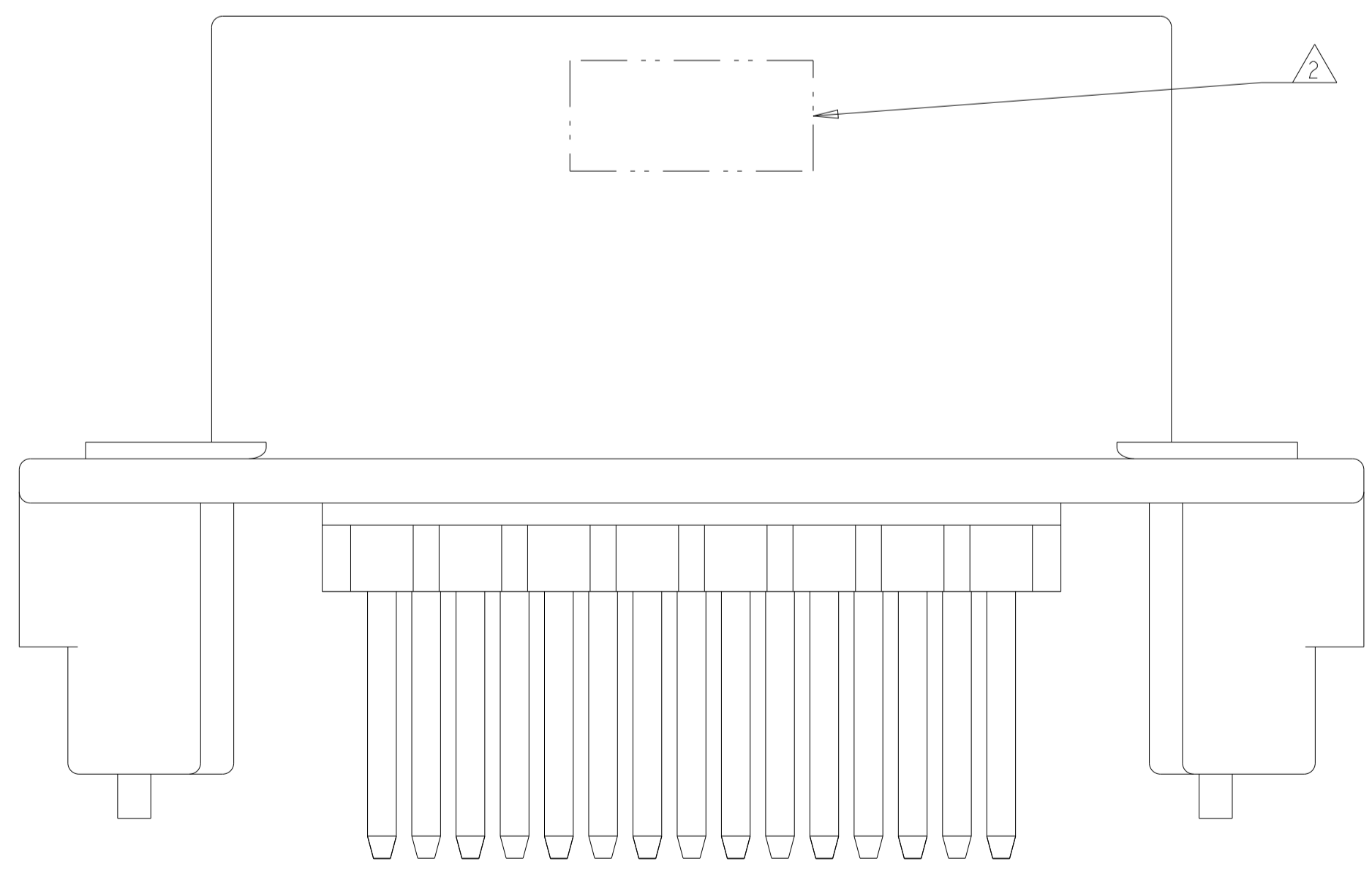

776200-1 & 1-776200-1 SHOWN

HEADER COLOR	PLATING	PART NUMBER
BLUE	GOLD	1-776200-5
GRAY	GOLD	1-776200-4
NATURAL	GOLD	1-776200-2
BLACK	GOLD	1-776200-1
BLUE	TIN	776200-5
GRAY	TIN	776200-4
NATURAL	TIN	776200-2
BLACK	TIN	776200-1

THIS DRAWING IS A CONTROLLED DOCUMENT.

DIMENSIONS: mm 	TOLERANCES UNLESS OTHERWISE SPECIFIED: 0 PLC ± 0.2 1 PLC ± 0.2 2 PLC ± 0.2 3 PLC ± 0.2 4 PLC ± 0.2 ANGLES ± 0.1 FINISH ± 0.1	DWN: D. STRAUSSER 04FEB2010 CHK: D. STRAUSSER 22MAR2010 APVD: D. STRAUSSER 27APR2010 NAME: D. STRAUSSER PRODUCT SPEC: 108-1329 APPLICATION SPEC: 114-16016 WEIGHT: 22.48g CUSTOMER DRAWING	DATE: 04FEB2010 NAME: D. STRAUSSER PRODUCT SPEC: 108-1329 APPLICATION SPEC: 114-16016 WEIGHT: 22.48g CUSTOMER DRAWING	SIZE: A1 CAGE CODE: 00779 DRAWING NO: 776200 RESTRICTED TO: - SCALE: 4:1 SHEET: 1 OF 2 REV: E
-----------------------	---	---	--	---

TE Connectivity

HEADER ASSEMBLY,
23 POSITION, VERTICAL,
AMPSEAL

REVISIONS				
P	LTN	DESCRIPTION	DATE	APVD
-	-	SEE SHEET 1	-	-

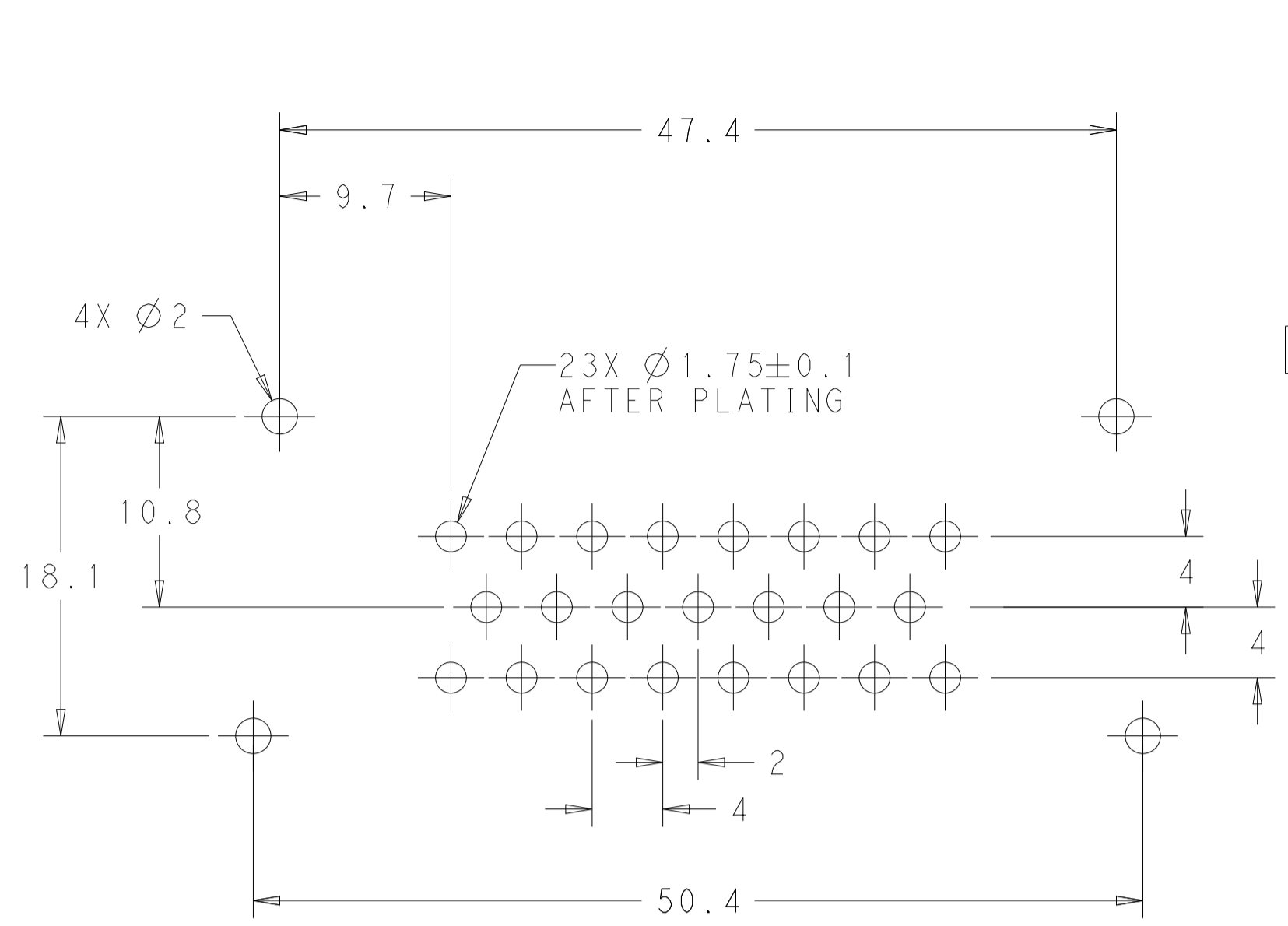

RECOMMENDED P.C. BOARD LAYOUT
 FOR 1.57 THICK P.C. BOARD

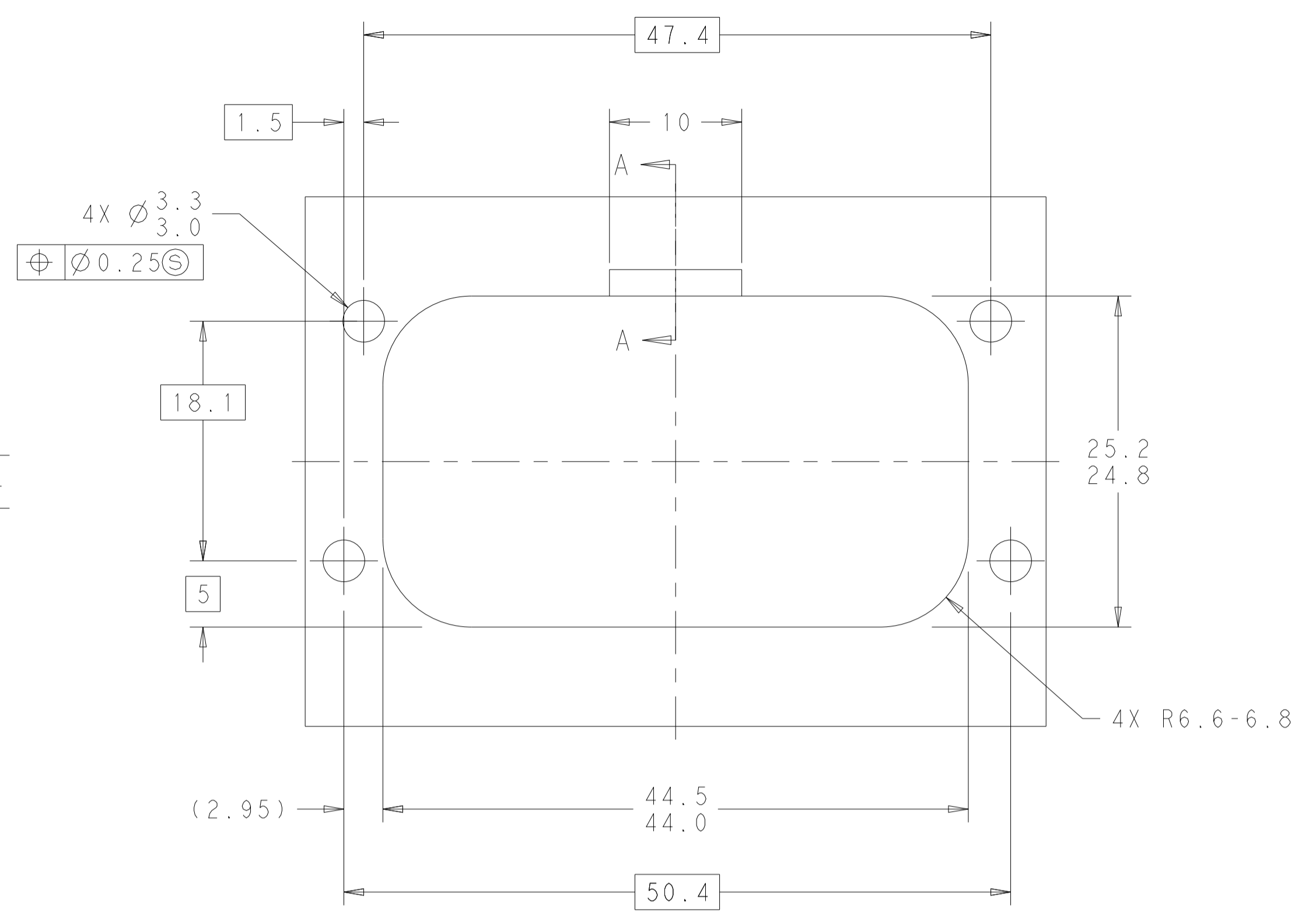

RECOMMENDED MOUNTING HOLE LAYOUT
 FOR 5.0 MAX THICK PANEL

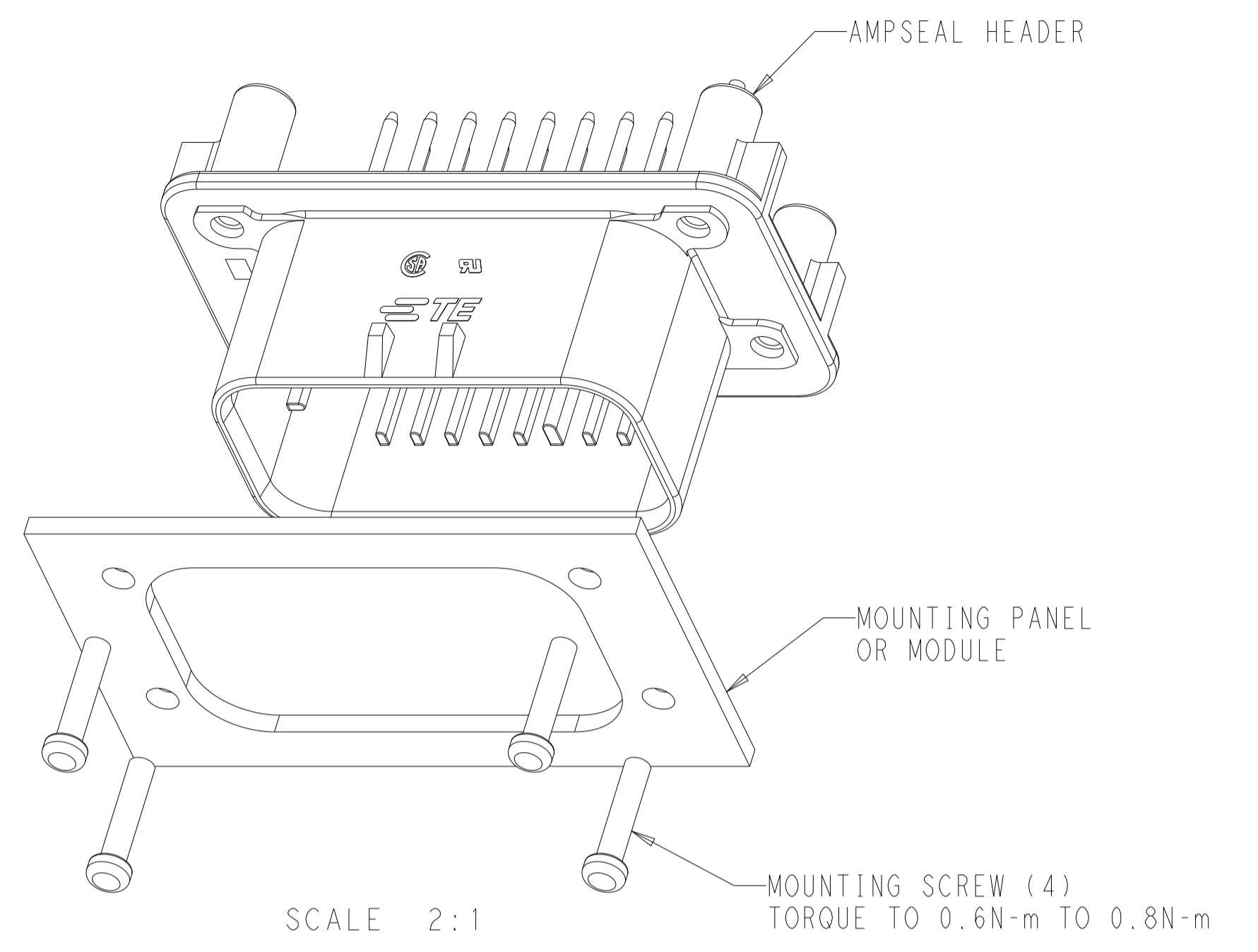

SCALE 2:1

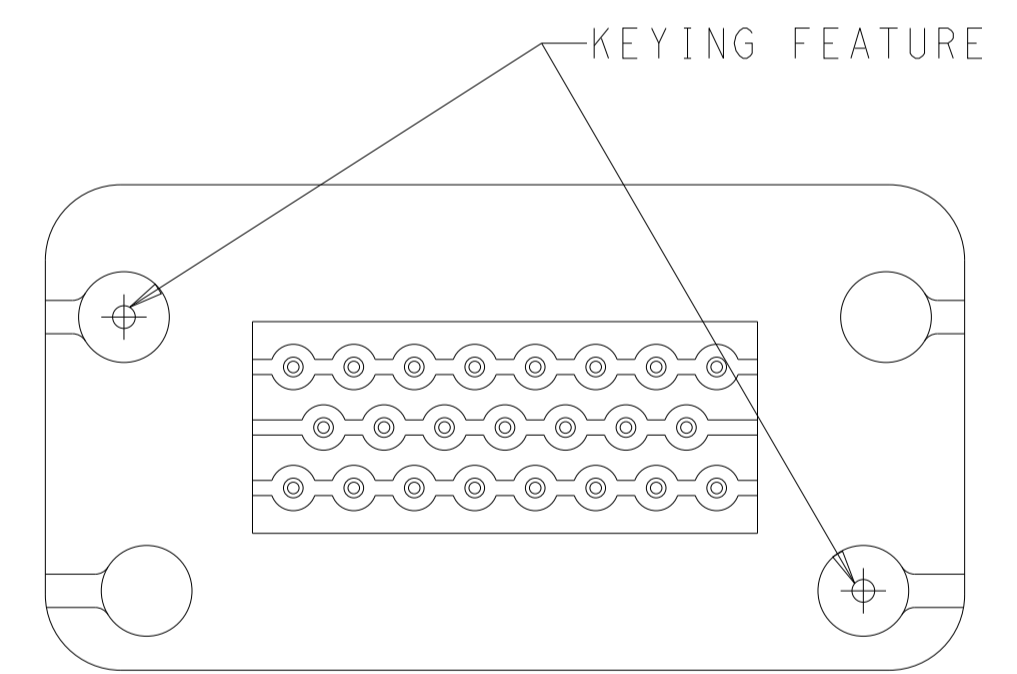

KEYING FOR 776200-1 AND 776200-5
 SCALE 2:1

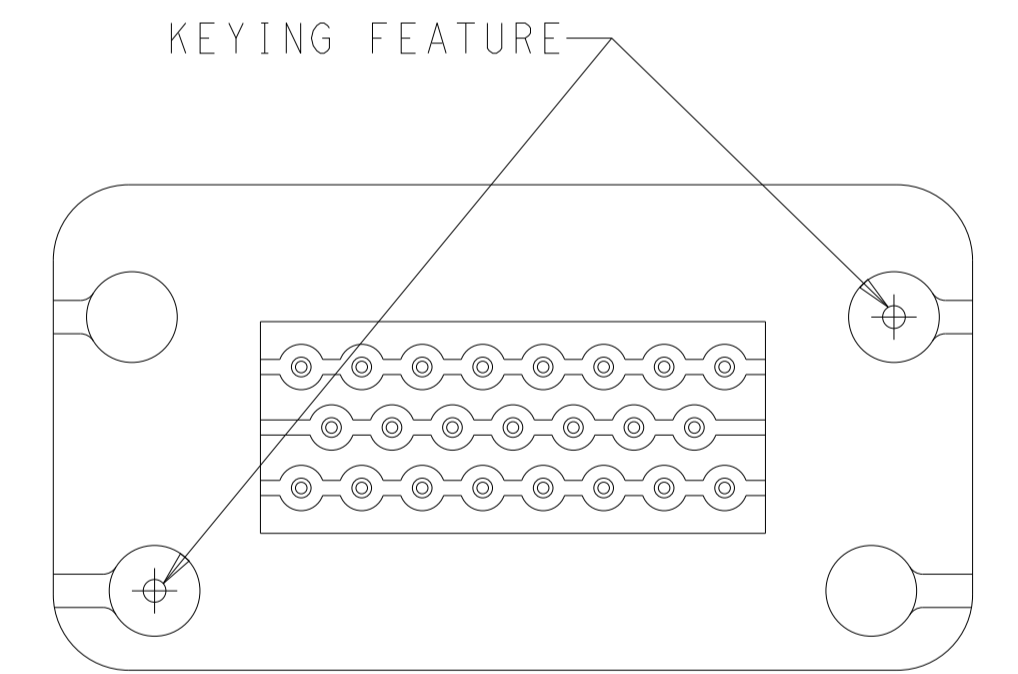

KEYING FOR 776200-2 AND 776200-4
 SCALE 2:1

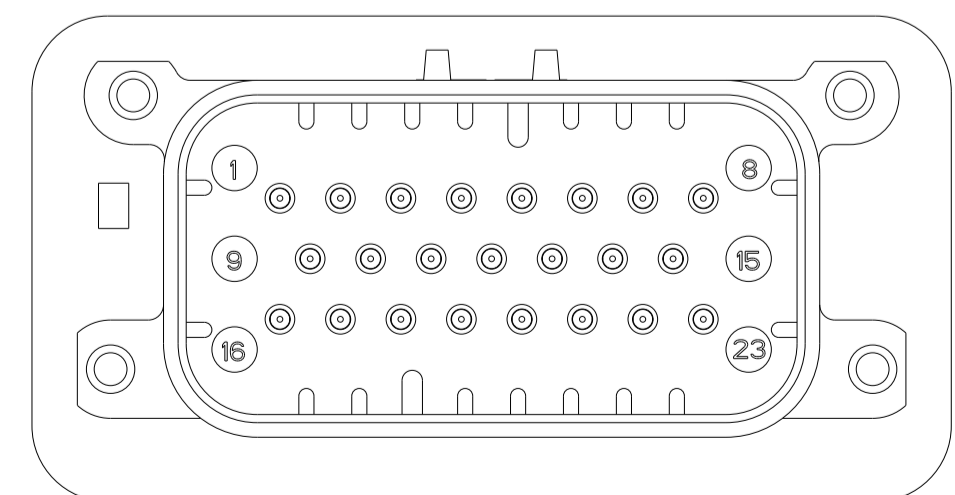

776200-2 & 1-776200-2
 KEY LOCATION
 SCALE 2:1

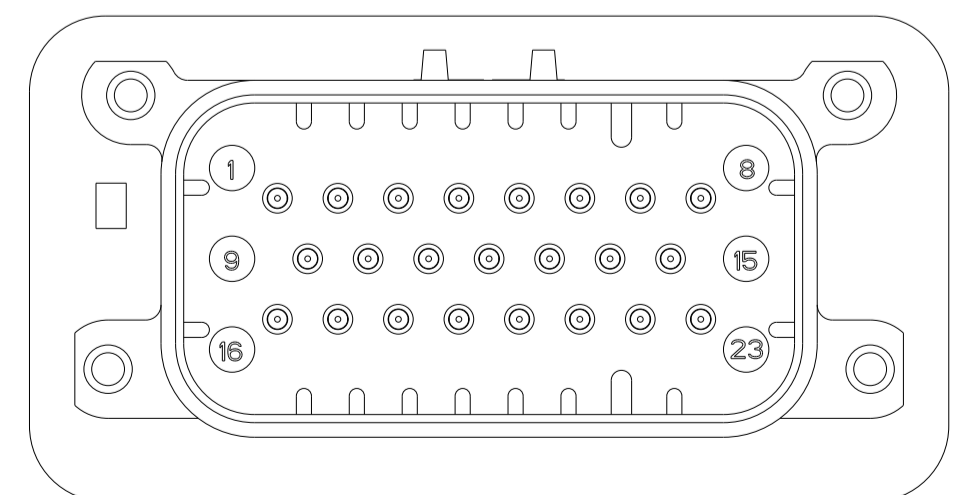

776200-4 & 1-776200-4
 KEY LOCATION
 SCALE 2:1

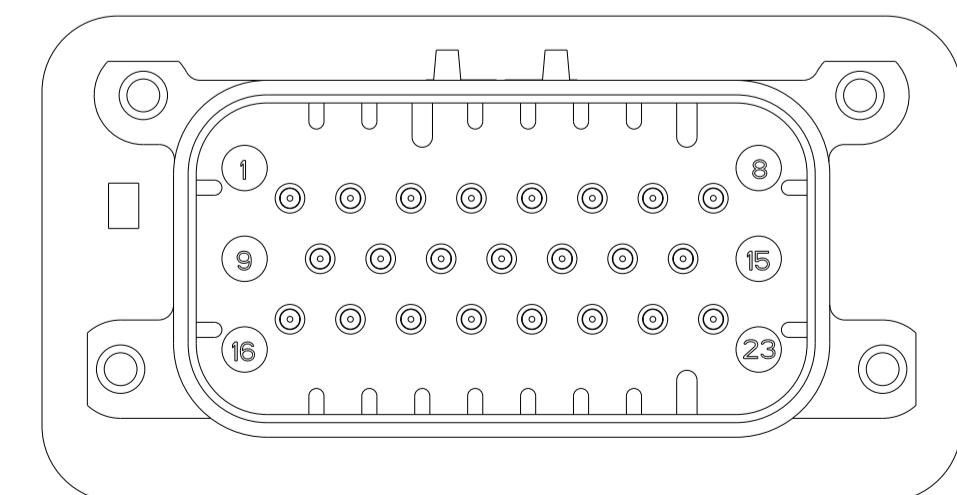

776200-5 & 1-776200-5
 KEY LOCATION
 SCALE 2:1

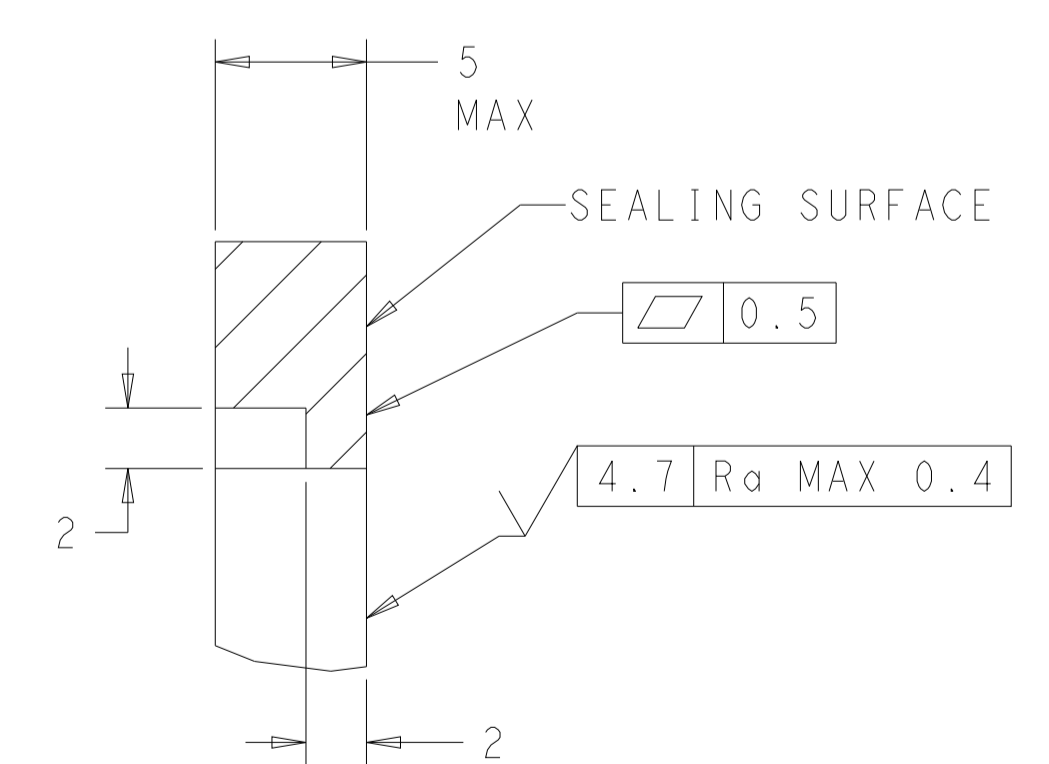
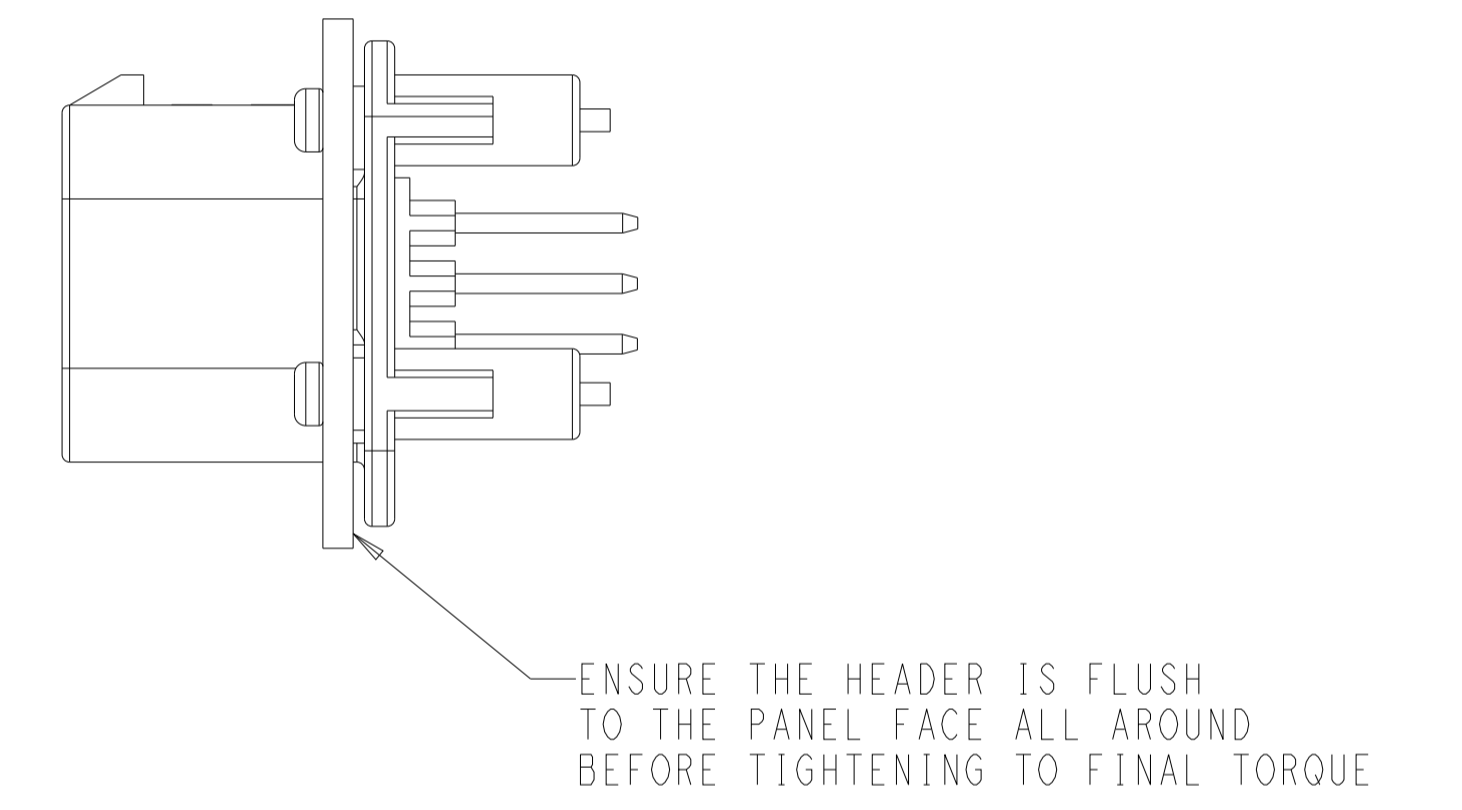

SECTION A-A
 OPTIONAL CONSTRUCTION IF PANEL
 THICKNESS IS GREATER THAN 2.0
 SCALE 4:1

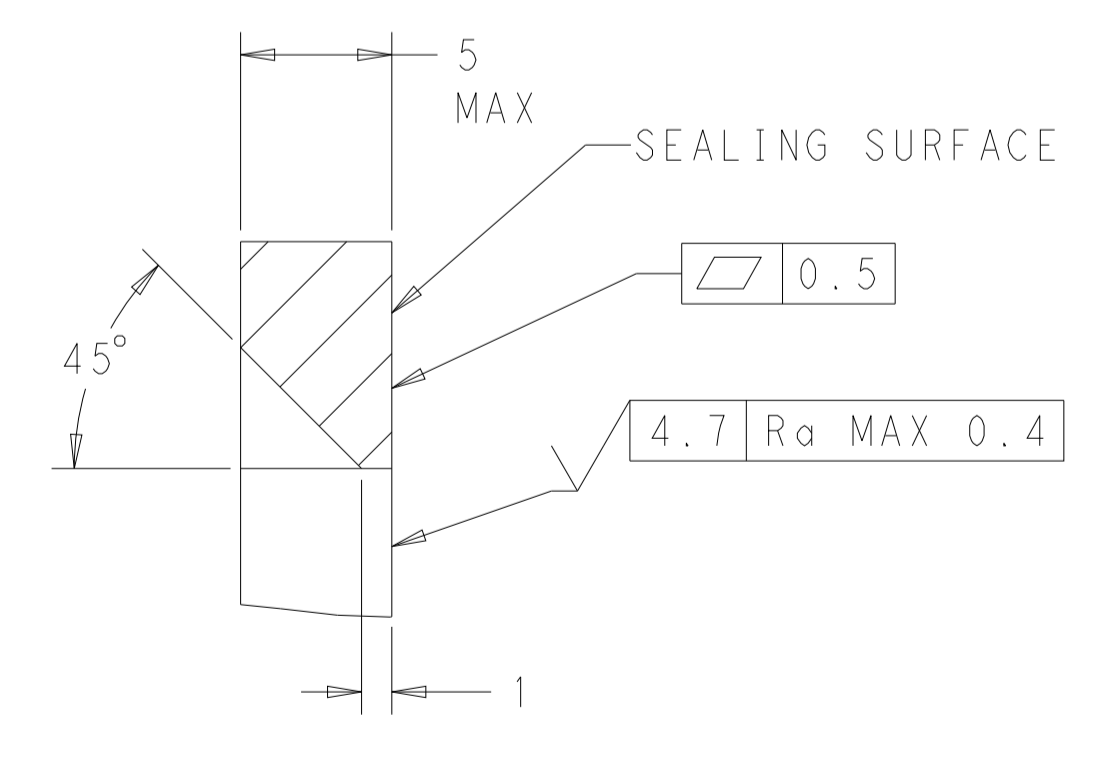

SECTION A-A
 OPTIONAL CONSTRUCTION IF PANEL
 THICKNESS IS GREATER THAN 2.0
 SCALE 4:1

THIS DRAWING IS A CONTROLLED DOCUMENT.		OWN: D. STRAUSSER 04FEB2010	TE Connectivity	
DIMENSIONS: mm		CHK: D. STRAUSSER 22MAR2010		
TOLERANCES UNLESS OTHERWISE SPECIFIED:		APVD: D. STRAUSSER 27APR2010	NAME: HEADER ASSEMBLY, 23 POSITION, VERTICAL, AMPSEAL	
0 PLC ±0.2		PRODUCT SPEC: 108-1329	SIZE: CAGE CODE: DRAWING NO: 114-16016	
1 PLC ±0.2		APPLICATION SPEC: 114-16016	RESTRICTED TO: -	
2 PLC ±0.2		WEIGHT: 22.48g	SCALE: 4:1 SHEET 2 OF 2 REV E	
3 PLC ±0.2		CUSTOMER DRAWING	A100779C=776200	
4 PLC ±0.2				
ANGLES FINISH ±				

X-ON Electronics

Largest Supplier of Electrical and Electronic Components

Click to view similar products for [Automotive Connectors](#) category:

Click to view products by [TE Connectivity](#) manufacturer:

Other Similar products are found below :

[003-018-000](#) [60403001](#) [60993906-B](#) [M902-2131](#) [M902-2161](#) [72.330.1035.1](#) [73.353.4028.0](#) [F119300-B](#) [F166900](#) [F258300-B](#) [F358300-B](#)
[F407400](#) [F444110](#) [F487000](#) [F509500B-B](#) [827153-1](#) [8N1515-32-24P](#) [9-1326729-8](#) [925474-1](#) [928905-1](#) [964562-4](#) [968782-1](#) [GT17SA-8DS-](#)
[HU](#) [98891-1012](#) [98947-1016](#) [12004147](#) [12004475-L](#) [12010290](#) [12010309-B](#) [12015454](#) [12020219-B](#) [12020308](#) [12041318-B](#) [12052225-L](#)
[12052466](#) [12059125](#) [12064869](#) [12004327-B](#) [12010503-B](#) [12015308](#) [12015384](#) [12015909](#) [1-21030-1](#) [12041254](#) [12041318](#) [12047946-B](#)
[12047957](#) [12047957-L](#) [12059473](#) [12066261](#)