

THIS DRAWING IS UNPUBLISHED. RELEASED FOR PUBLICATION
 © COPYRIGHT - By - ALL RIGHTS RESERVED.

REVISIONS					
P	LTR	DESCRIPTION	DATE	DWN	APVD
E1		REVISED PER ECO-16-004223	20JUL2016	NK	MZ
F		REVISED PER ECO-16-017885	06OCT2017	RS	MZ

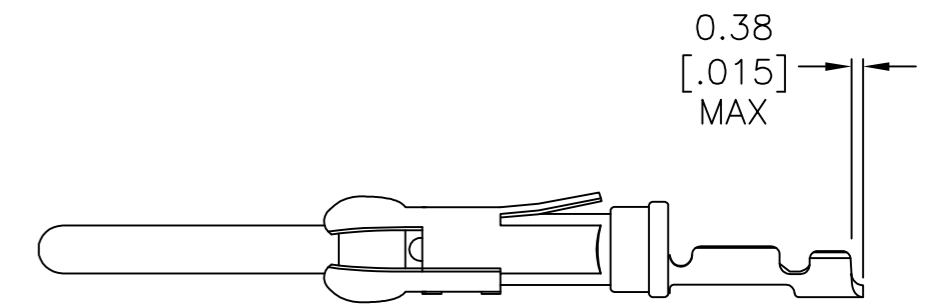

DETAIL C
 SCALE 4:1

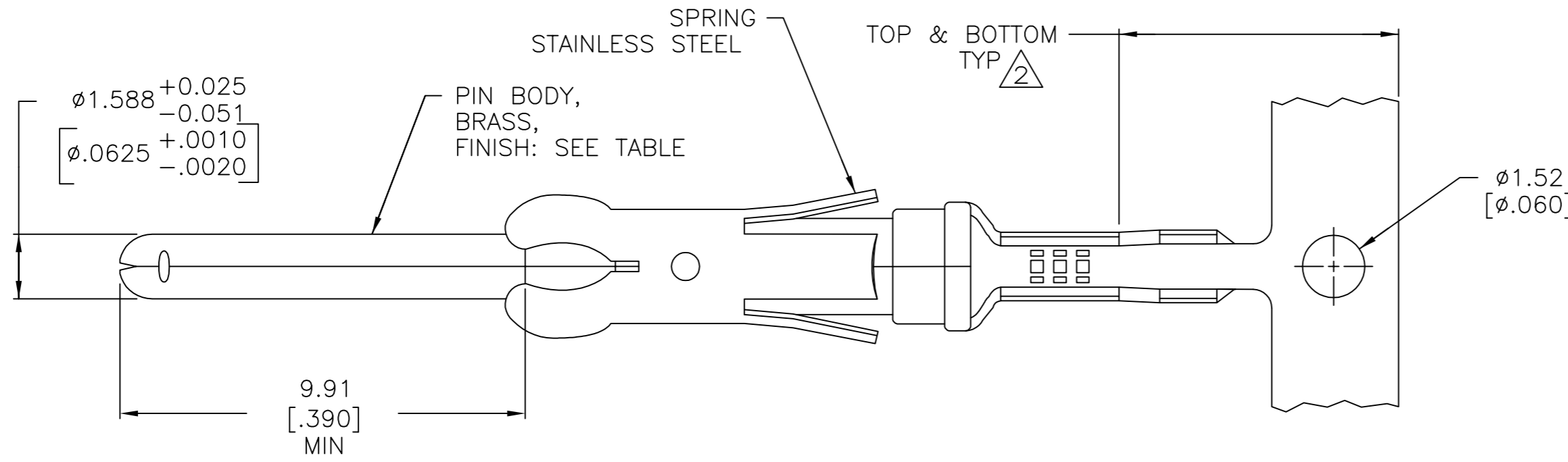
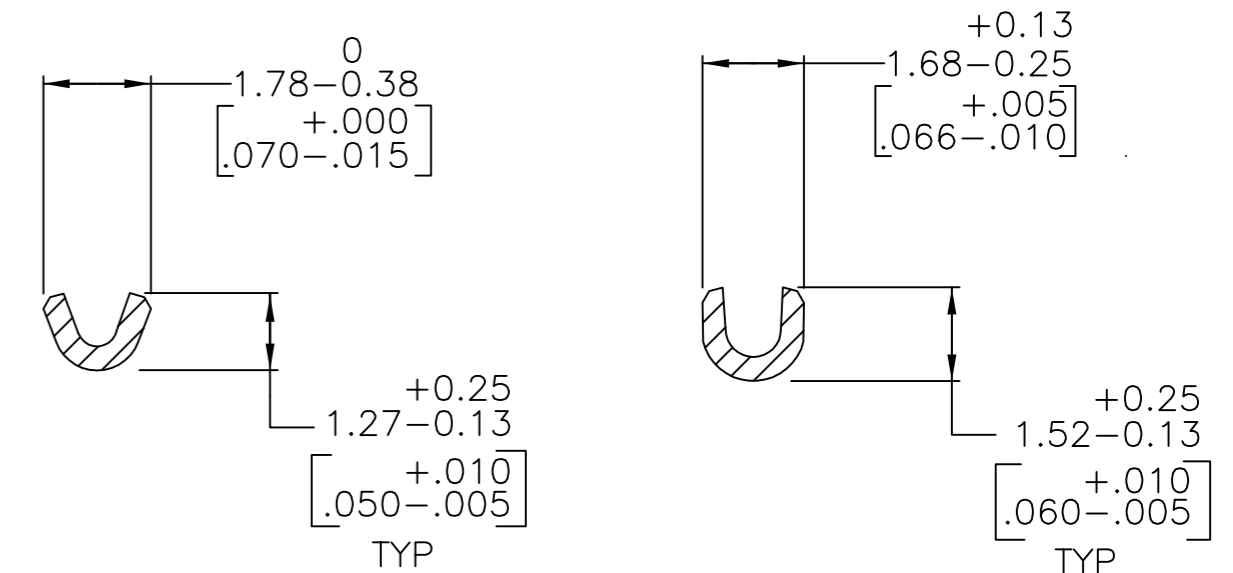
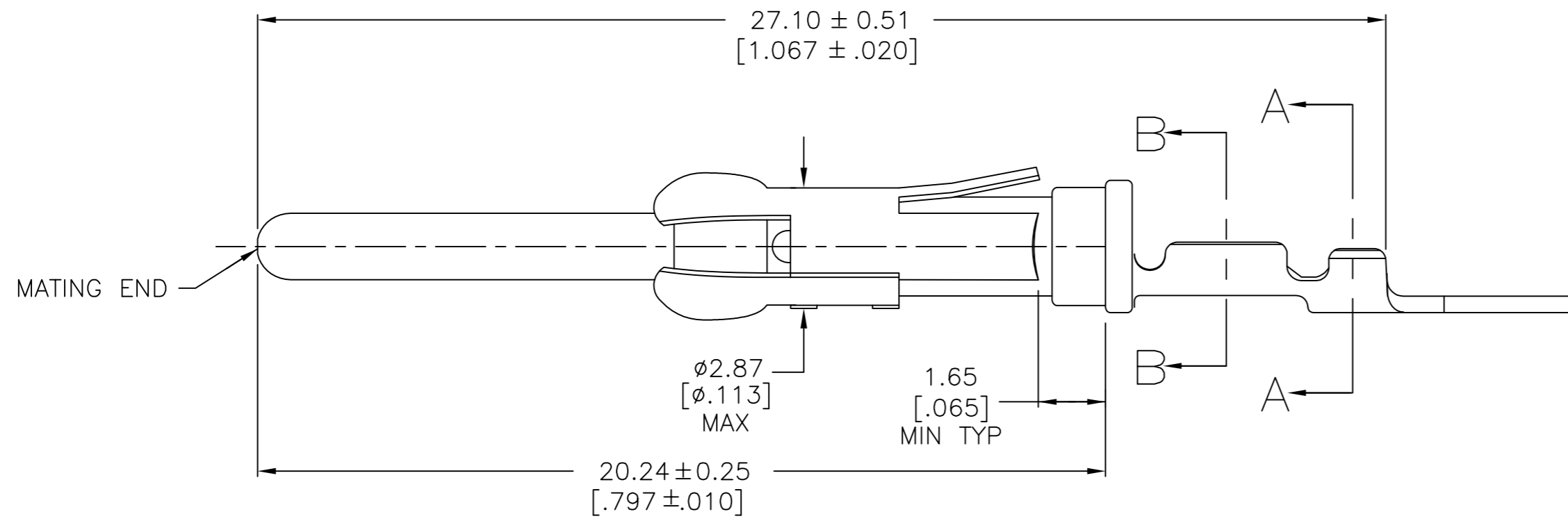

- $\triangle 1$ 0.76 μm [.000030] MIN PRECIOUS METAL PLATE ON MATING END FOR A LENGTH OF 5.08 [.200] MIN WITH 1.27 μm [.000050] MIN MATTE TIN PLATE IN WIRE CRIMP AREA, BOTH OVER 1.27 μm [.000050] MIN NICKEL PLATE. CONFORMS TO THE REQUIREMENTS OF TE CONNECTIVITY PRODUCT SPEC 108-10042, BASED ON EIA/ECA-364-1000.01A (CONTROLLED ENVIRONMENT APPLICATIONS).
- $\triangle 2$ GOLD PLATING NEED NOT APPEAR IN THIS AREA.
- 3 REELED FOR MINI-APPLICATOR.
- 4 WIRE RANGE 28-30 AWG. INSULATION RANGE $\phi 3.81[\phi 0.15]$ - $\phi 7.62[\phi 0.30]$.
- $\triangle 5$ 0.76 μm [.000030] MIN PRECIOUS METAL PLATE ON MATING END FOR A LENGTH OF 5.08 [.200] MIN WITH A UNIFORM GRADIENT TO 0.25 μm [.000010] ON REMAINDER, OVER 1.27 μm [.000050] MIN NICKEL PLATE. GOLD FLASH ALL OVER. CONFORMS TO THE REQUIREMENTS OF TYCO ELECTRONICS PRODUCT SPEC 108-10042, BASED ON EIA/ECA-364-1000.01A (CONTROLLED ENVIRONMENT APPLICATIONS).
- $\triangle 6$ 0.38 μm [.000015] MIN GOLD PER MIL-G-45204 ON MATING END FOR A LENGTH OF 5.08 [.200] MIN WITH 1.27 μm [.000050] MIN MATTE TIN PLATE IN WIRE CRIMP AREA, BOTH OVER 1.27 μm [.000050] MIN NICKEL PER QQ-N-290.

OBSOLETE	PER DETAIL C	$\triangle 1$	788085-4
	-	$\triangle 6$	788085-3
OBSOLETE	-	$\triangle 5$	788085-2
	-	$\triangle 1$	788085-1
	LOOSE PIECE	FINISH	PART NUMBER

THIS DRAWING IS A CONTROLLED DOCUMENT.		DWN 21 NOV 96 C.OBERMAN		
DIMENSIONS: mm [INCHES]		CHK 22 NOV 96 R.STONE		
TOLERANCES UNLESS OTHERWISE SPECIFIED:		APVD 22 NOV 96 G.STEINHAUER	NAME PIN ASSEMBLY, .062, TYPE III+	
ϕ 0 PLC \pm - 1 PLC \pm - 2 PLC \pm 0.13 [.005] 3 PLC \pm - 4 PLC \pm - ANGLES \pm -		PRODUCT SPEC 108-10042	SIZE A2	CAGE CODE 00779
MATERIAL SEE CALLOUTS		APPLICATION SPEC 114-10004	DRAWING NO C=788085	RESTRICTED TO -
FINISH SEE CALLOUTS		WEIGHT -	SCALE 4:1	SHEET 1 of 1
CUSTOMER DRAWING			REV F	

X-ON Electronics

Largest Supplier of Electrical and Electronic Components

Click to view similar products for [Standard Circular Contacts](#) category:

Click to view products by [TE Connectivity](#) manufacturer:

Other Similar products are found below :

[RC16M23J](#) [133780-1](#) [RM20M13D28](#) [RM24M9D28](#) [RMMX110-1D28](#) [MS3474W10-6P L/C](#) [ELFH02211](#) [ELVP16100E](#) [164-901-CD](#)
[EN3545007SCE](#) [BV002BSQ20049CZ](#) [BV002SSQ160404CZ](#) [1900ND05S1B00B](#) [166566-1](#) [1900ND04S1X00D](#) [ST-JL05-16S-C3-100](#) [ST-JL05-20S-C1-100](#) [ST-JL05-20S-C2-100](#) [T01-CRIMP-S03](#) [APK-SA16A07-002](#) [27963-15T12](#) [CONT-JL05-08S-C2-10](#) [CONT-JL05-12S-C1-10](#) [RC16M-23T](#) [RFD26L-1D28](#) [BV002ASJ16049CW](#) [JN1-22-20S-R-PKG100](#) [031-50213](#) [031-50565](#) [031-50794](#) [SJS861301M](#) [ST-JL05-16S-C1-100](#) [ST-JL05-20P-C1-100](#) [82911466K](#) [192991-0087](#) [192900-0570](#) [44-100-1414P-1000-101](#) [T3P16FC3LZ](#) [ST-JL05-16S-C2-3500](#)
[ZP-4016-10NF](#) [CONT-JL05-12P-C1-10](#) [RM20M12G8D28](#) [031-50676](#) [12115010110](#) [RJFTVC2MG](#) [CAP-DACMDPC2](#) [031-50675-002](#)
[CAP-DD1FDPC2](#) [CAP-DACMDPC1](#) [031-50966-010](#)