

THIS DRAWING IS UNPUBLISHED. RELEASED FOR PUBLICATION 20
 © COPYRIGHT 20 BY - ALL RIGHTS RESERVED.

LOC		DIST		REVISIONS			
P	LTR	DESCRIPTION	DATE	DWN	APVD		
E3		REVISED PER ECO-11-008211	21APR2011	HMR	CR		

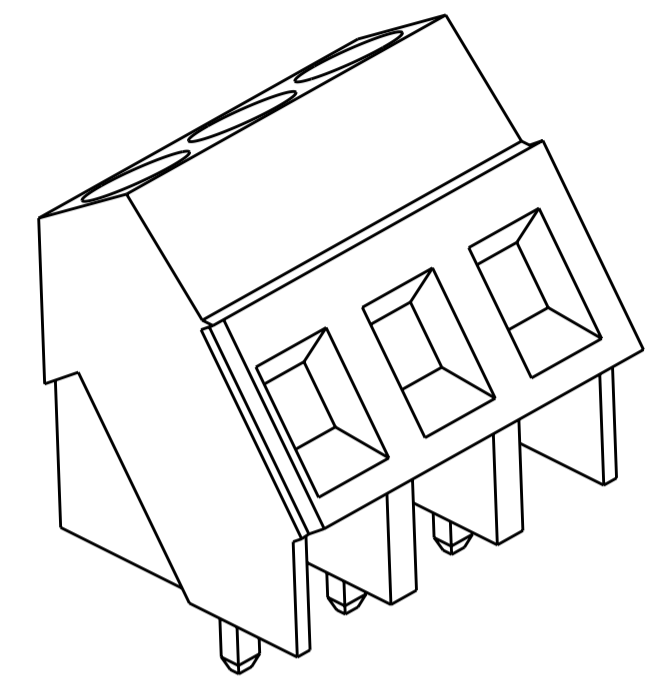

796690-3 AS SHOWN

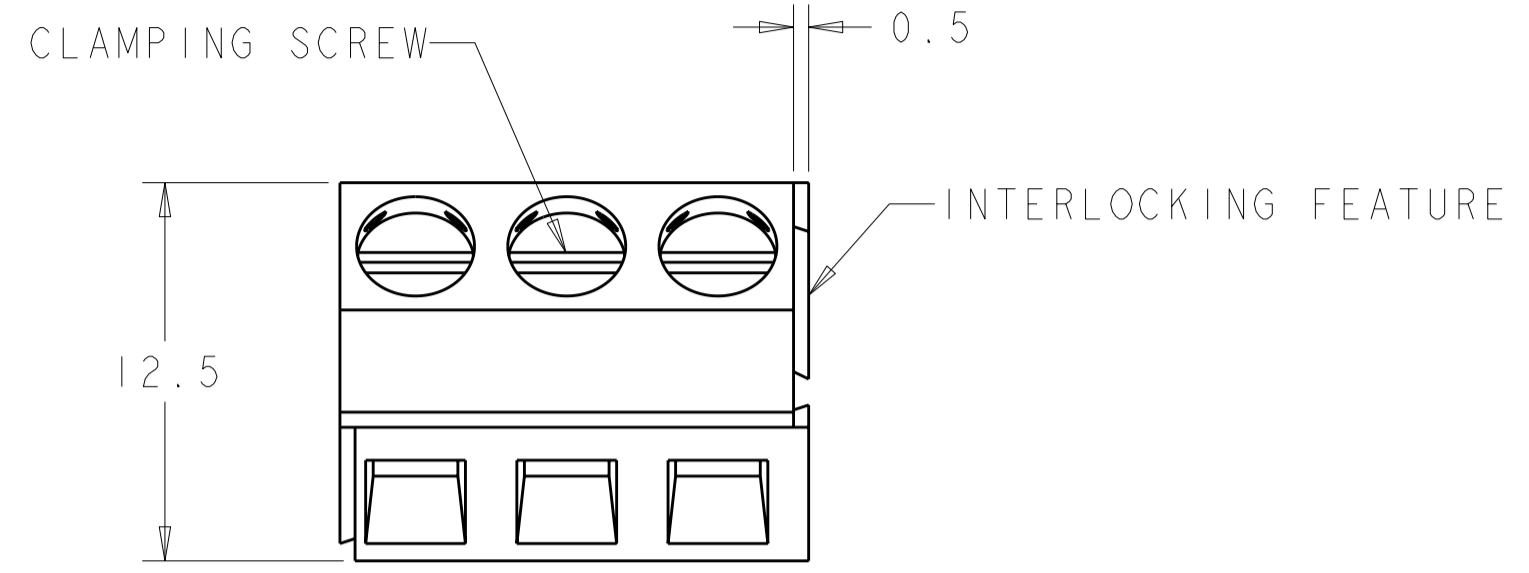
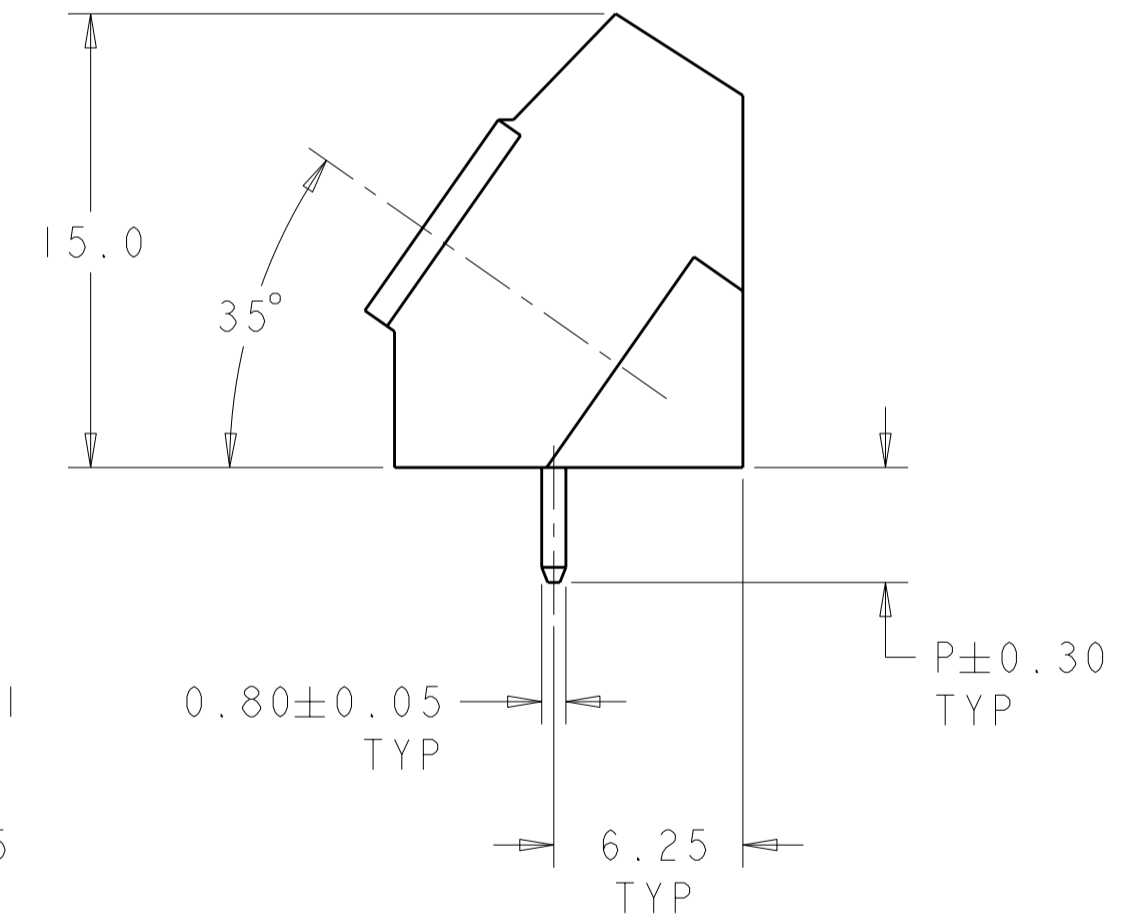
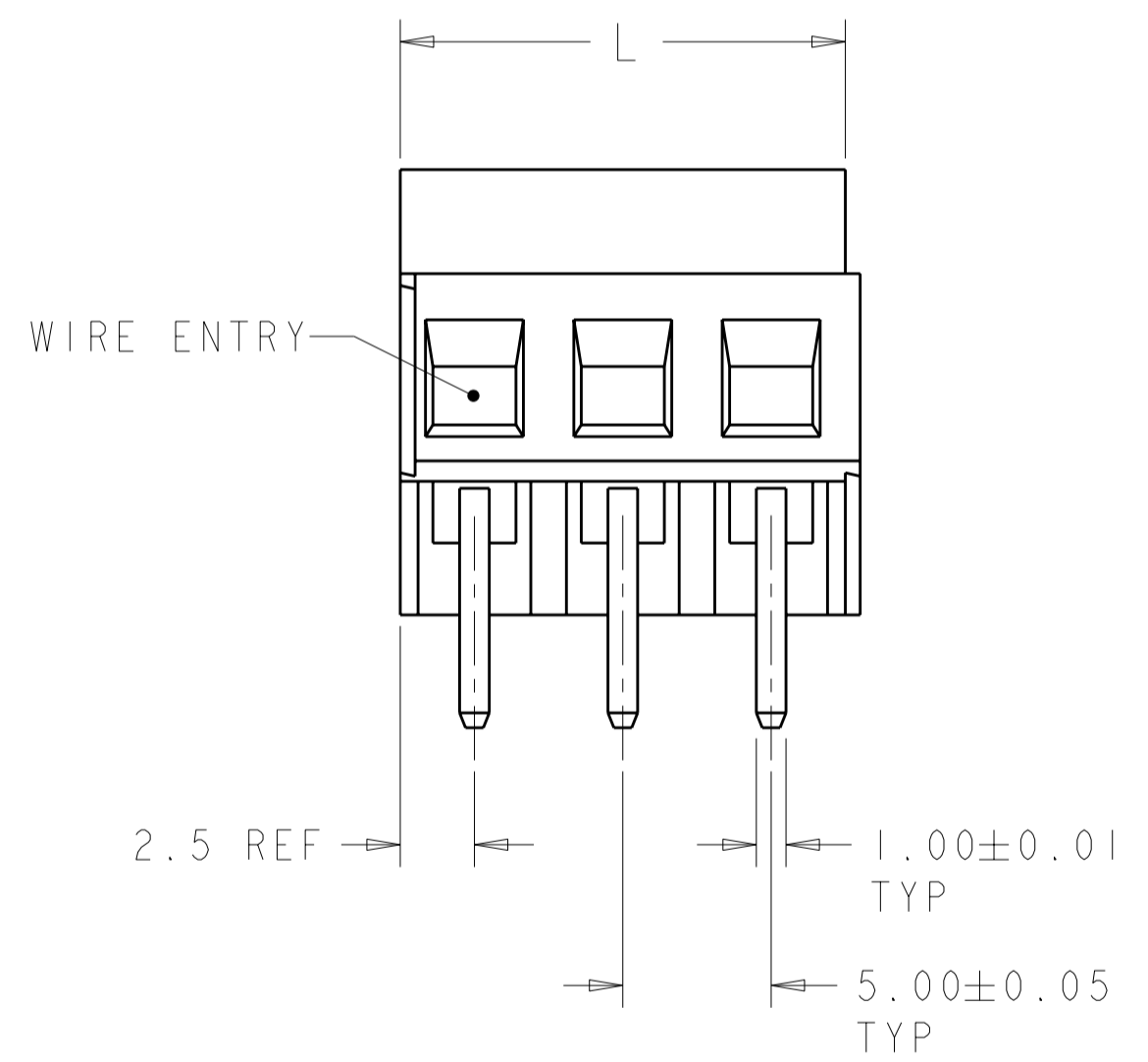

BLACK	SEE DETAIL J	3.8	10	2	5-796690-6
BLACK	SEE DETAIL H	3.8	10	2	5-796690-5
BLACK	SEE DETAIL G	3.8	10	2	5-796690-4
-	-	6.0	15	3	5-796690-3
-	-	-	10	2	5-796690-2
9	SEE DETAIL B	3.8	10	2	4-796690-2
8	SEE DETAIL F	-	40	8	3-796690-8
9	SEE DETAIL C	-	15	3	3-796690-3
-	-	-	100	20	2-796690-0
9	SEE DETAIL C	-	15	3	1-796690-9
9	SEE DETAIL B	-	10	2	1-796690-8
-	-	6.0	15	3	1-796690-7
-	-	-	10	2	1-796690-6
8	SEE DETAIL E	3.8	25	5	1-796690-5
8	SEE DETAIL D	-	20	4	1-796690-4
8	SEE DETAIL A	-	10	2	1-796690-3
-	-	-	60	12	1-796690-2
-	-	-	55	11	1-796690-1
-	-	-	50	10	1-796690-0
-	-	-	45	9	796690-9
-	-	-	40	8	796690-8
-	-	-	35	7	796690-7
-	-	-	30	6	796690-6
-	-	-	25	5	796690-5
-	-	-	20	4	796690-4
-	-	-	15	3	796690-3
-	-	-	10	2	796690-2

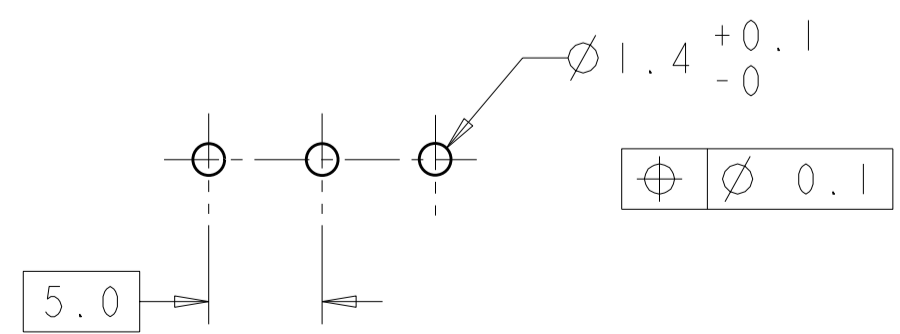

RECOMMENDED PC BOARD LAYOUT

THIS DRAWING IS A CONTROLLED DOCUMENT.

DIMENSIONS:	TOLERANCES UNLESS OTHERWISE SPECIFIED:	DWN	14MAR2001	TE Connectivity NAME TERMINAL BLOCK, PCB MOUNT ANGLED WIRE ENTRY, STACKING W/INTERLOCK, 5mm PITCH			
mm	0 PLC ±3 1 PLC ±.3 2 PLC ±.25 3 PLC ±. 4 PLC ±. ANGLES ±2 FINISH	CHK	14MAR2001				
		APVD	14MAR2001				
		PRODUCT SPEC	108-20166				
MATERIAL		APPLICATION SPEC	114-20079	SIZE	CAGE CODE	DRAWING NO	RESTRICTED TO
		WEIGHT	-	A2	00779	C-796690	-
CUSTOMER DRAWING			SCALE	3:1	SHEET	1 OF 2	REV E3

THIS DRAWING IS UNPUBLISHED. RELEASED FOR PUBLICATION 20
 © COPYRIGHT 20 BY - ALL RIGHTS RESERVED.

LOC	DIST	REVISIONS			
P	LTR	DESCRIPTION	DATE	DWN	APVD
FT	0	-	SEE SHEET 1	-	-

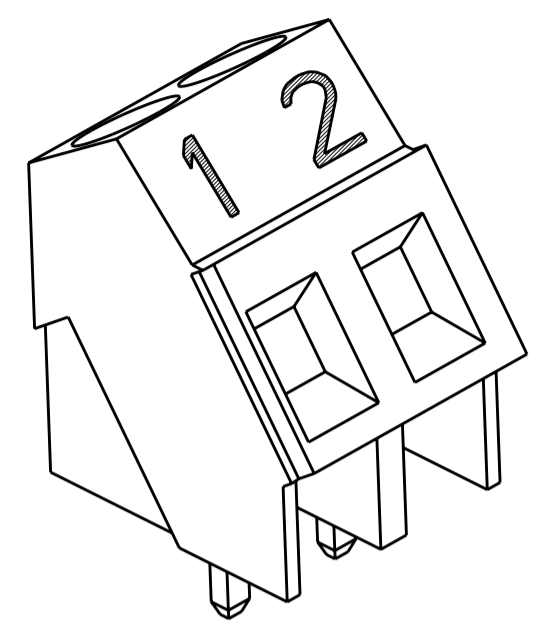

DETAIL A

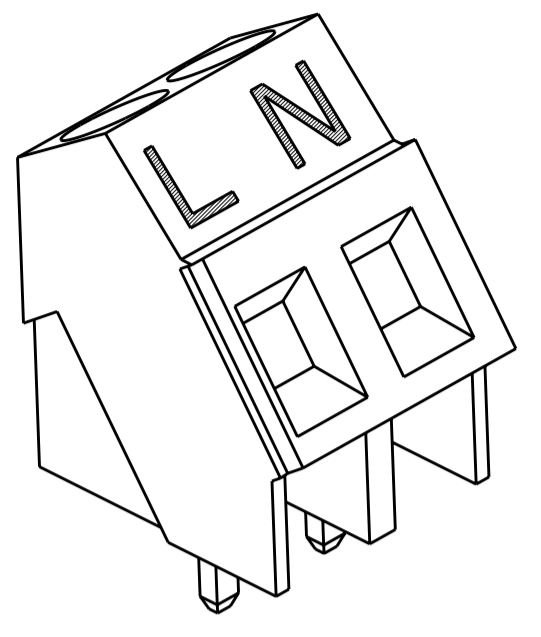

DETAIL B

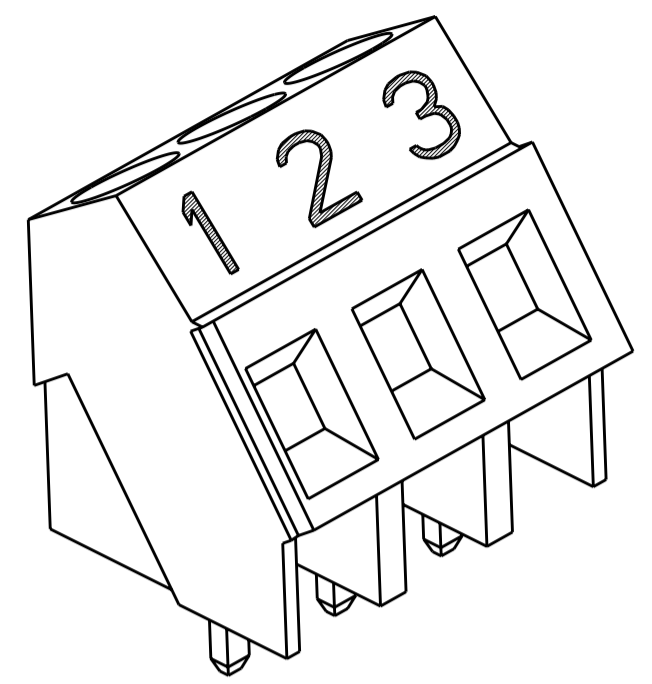

DETAIL C

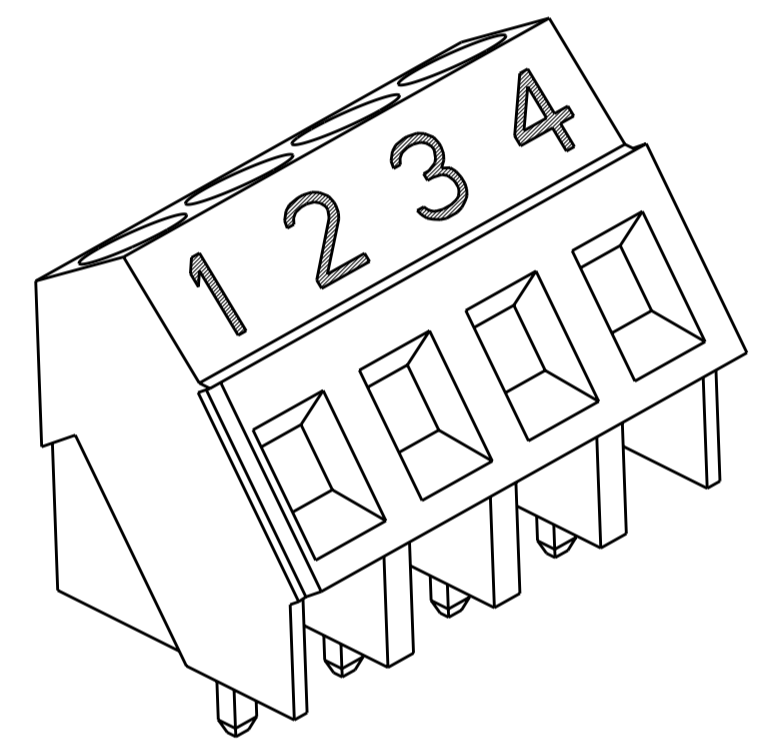

DETAIL D

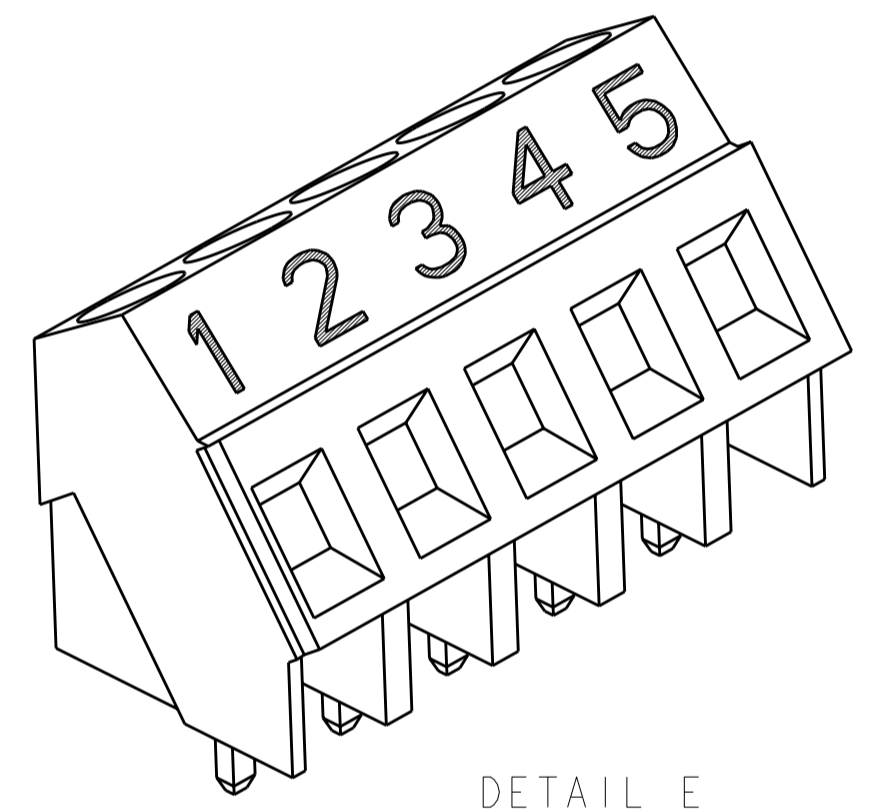

DETAIL E

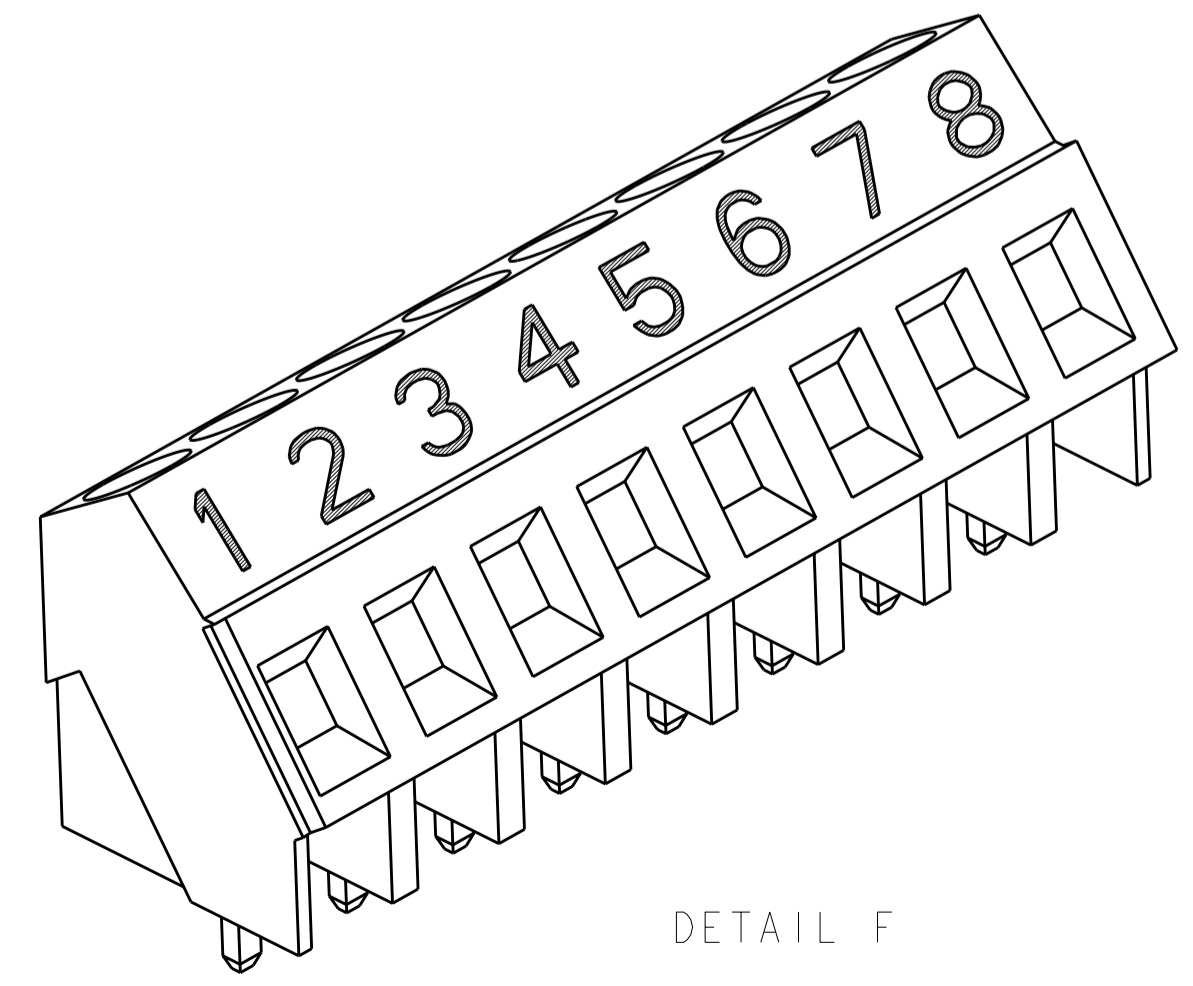

DETAIL F

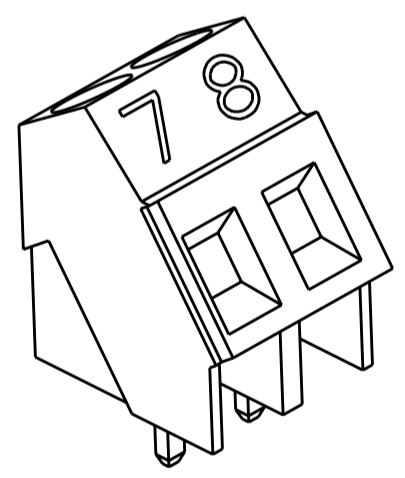

DETAIL G

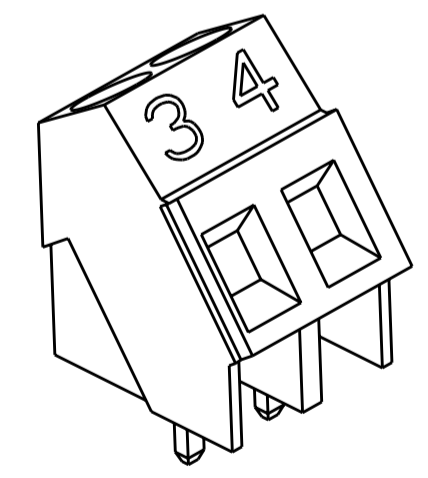

DETAIL H

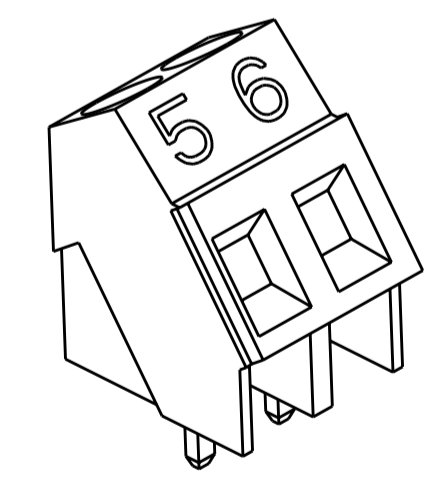

DETAIL J

- 1. MATERIALS AND FINISH:
 HOUSING: PA 6-6, UL 94-V0, COLOR GREEN.
 CLAMP: BRASS, NICKEL PLATED.
 TERMINAL: BRASS, TIN PLATED.
 CLAMPING SCREW: M3, BRASS, NICKEL PLATED.
- 2. SUITABLE FOR 1,6-2,4mm PCB THICKNESS.
- 3. END-TO-END STACKABLE W/INTERLOCK, WITHOUT LOSS OF CENTERLINE SPACING.
- 4. WIRE RANGE: 12-30 AWG.
- 5. RECOGNIZED UNDER THE COMPONENT PROGRAM OF UNDERWRITERS LABORATORIES INC. FILE N° E60677.
- 6. IMO CERTIFICATE WITH SURVEILLANCE IN CONFORMITY WITH IEC 998-1/998-2-1.
- 7. NOT CUMULATIVE TOLERANCE.
- 8. INK MARKED WHITE, UNLESS OTHERWISE SPECIFIED. NUMERICAL SEQUENCE FROM LEFT TO RIGHT.
- 9. INK MARKED BLACK, UNLESS OTHERWISE SPECIFIED. NUMERICAL SEQUENCE FROM LEFT TO RIGHT.
- 10. BUCHANAN LOGO TO APPEAR ON HOUSING, LOCATION OPTIONAL, WHERE SPACE PERMITS.

THIS DRAWING IS A CONTROLLED DOCUMENT.		DWN E. ZANOLINI 14MAR2001	TE Connectivity	
DIMENSIONS: mm		CHK D. BIEVENOUR 14MAR2001		
TOLERANCES UNLESS OTHERWISE SPECIFIED:		APVD D. BIEVENOUR 14MAR2001	NAME TERMINAL BLOCK, PCB MOUNT ANGLED WIRE ENTRY, STACKING W/INTERLOCK, 5mm PITCH	
0 PLC ±3 1 PLC ±3 2 PLC ±.25 3 PLC ±. 4 PLC ±. ANGLES ±2 FINISH		PRODUCT SPEC 108-20166	SIZE A200779	
MATERIAL		APPLICATION SPEC 114-20079	DRAWING NO C-796690	
		WEIGHT -	RESTRICTED TO -	
CUSTOMER DRAWING		SCALE 3:1 SHEET 2 OF 2 REV E3		

X-ON Electronics

Largest Supplier of Electrical and Electronic Components

Click to view similar products for [Fixed Terminal Blocks](#) category:

Click to view products by [TE Connectivity](#) manufacturer:

Other Similar products are found below :

[MBE-1512](#) [MBE-154](#) [MBE-156](#) [MBES-153](#) [MBES-156](#) [MH-2512](#) [MHE-132](#) [MHE-163](#) [MI-254 \(35\)](#) [MI-272](#) [880507](#) [MPT-275](#)
[15602-04-08-21](#) [ELM023100](#) [BA311TU](#) [BA411SU](#) [MV-152](#) [MV-252-D](#) [MV-253/NCNOC](#) [MV-254-D](#) [MV-255](#) [MV-462](#) [MV-493](#) [MVE-](#)
[252](#) [MVE-253](#) [MVE-273](#) [MVEB-153](#) [1700096](#) [1705142](#) [1712417](#) [1713020](#) [1713088](#) [1745195](#) [1760594](#) [1776118-2](#) [1790852](#) [1-796689-8](#)
[1-796692-6](#) [1800001](#) [1800114](#) [1995279](#) [20020314-C121B01LF](#) [CB2-12](#) [KP03215000J0G](#) [KP04215000J0G](#) [S451](#) [282802-2](#) [29.007](#) [29.116](#)
[30.103](#)