

THIS DRAWING IS UNPUBLISHED. RELEASED FOR PUBLICATION
 © COPYRIGHT - By - ALL RIGHTS RESERVED.

| LOC | DIST | REVISIONS | | | |
|-----|------|-------------|---------------------------|---------|--------|
| P | LTR | DESCRIPTION | DATE | DWN | APVD |
| G | 14 | L2 | REVISED PER ECO-11-004587 | 11MAR11 | RK HMR |

| | | |
|--------------------------------|---|---|
| AMP WIRE RANGE |  Listed FILE E13288 |  LR7189 Certified |
| 12-10 AWG SOLID OR STRANDED | 12-10 AWG SOLID OR STRANDED | 12-10 AWG SOLID OR STRANDED |

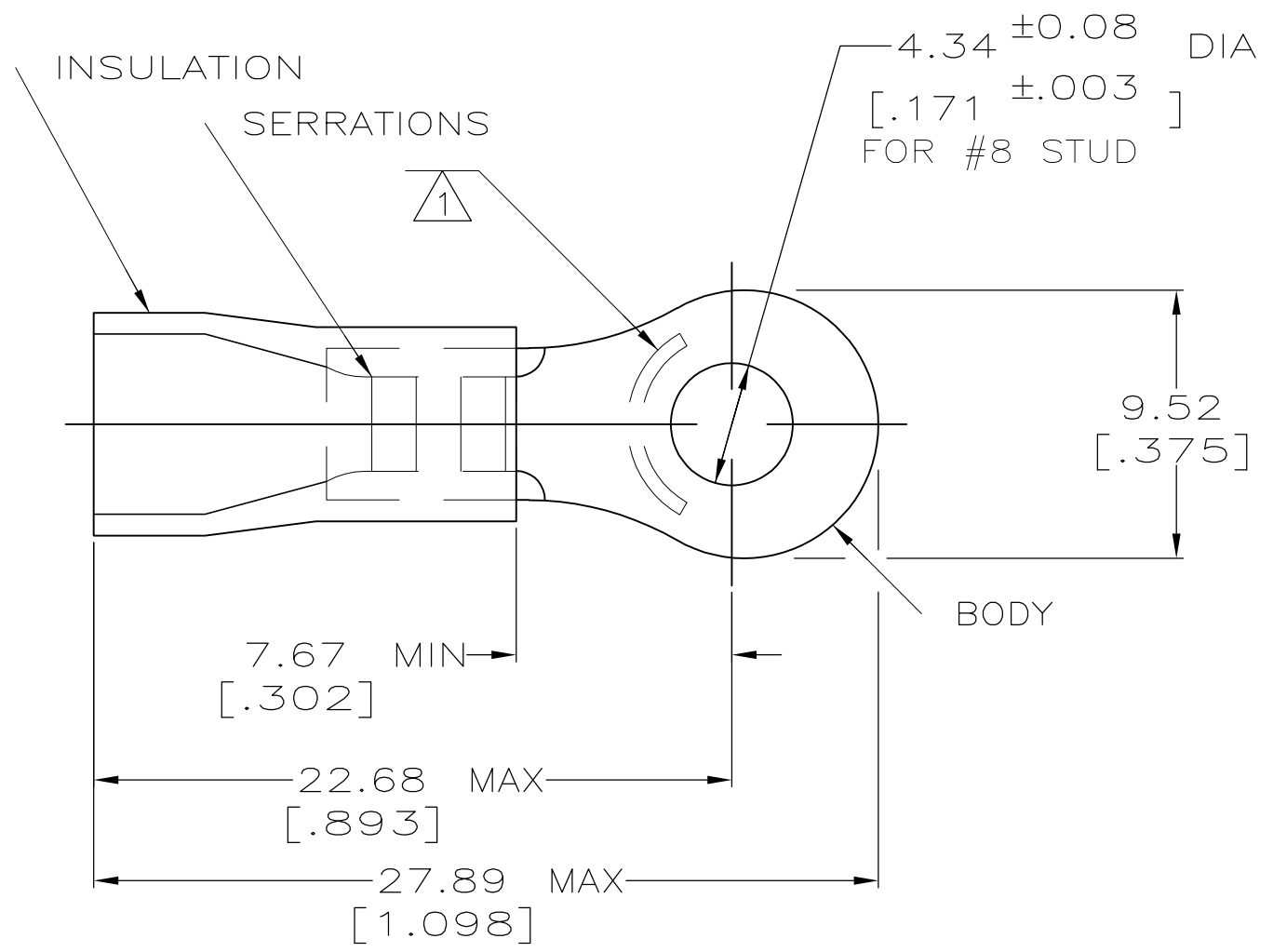

- ① STAMP AMP 12-10* APPROX AS SHOWN
- 2 WIRE INSULATION DIA: .150-.250
- 3 TONGUE MATERIAL THK: 1.02^{±0.05} [.040^{±.002}]

| | | |
|------|------------------|-----------|
| 25 | LOOSE PIECE, BAG | 8-34853-5 |
| 4 | LOOSE PIECE, BLS | 8-34853-4 |
| 100 | LOOSE PIECE, BOX | 8-34853-1 |
| 2500 | ON TAPE, REEL | 2-34853-1 |
| - | LOOSE PIECE | 34853 |
| QTY | PACKAGE TYPE | PART NO |

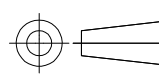
| | | | | | | | | | |
|--|--|---|---|--|------------------------------|---|--------------------|-----------------------|--------------------|
| AMP INCORPORATED CUSTOMER SERVICE SYSTEMS | | MAX RECOMMENDED OPERATING TEMPERATURE: 105°C [221°F] | THIS DRAWING IS A CONTROLLED DOCUMENT. | | DWN DK SCHRUM 08/06/92 |  TE Connectivity | | | |
| FOR ADDITIONAL PRODUCT INFORMATION OR COPIES OF DRAWINGS AND TECHNICAL DOCUMENTS | PRODUCT INFORMATION CENTER 1-800-522-6752 | VOLTAGE RATING: N/A | DIMENSIONS: INCHES | TOLERANCES UNLESS OTHERWISE SPECIFIED: | CHK RE HERSEY 11/10/92 | | | | |
| FOR APPLICATION TOOLING INFORMATION | TOOLING ASSISTANCE CENTER 1-800-722-1111 | CIRCULAR MIL AREA: 2.62-6.64mm ² [5,180-13,100] SOLID OR STRANDED |  | 0 PLC ± - 1 PLC ± - 2 PLC ± 0.20[.008] 3 PLC ± - 4 PLC ± - ANGLES ± - | APVD M BARNABA 11/10/92 | PRODUCT SPEC UL 486A | | | |
| FOR ORDER ENTRY | 1-800-526-5142 | THIS DRAWING IS A CONTROLLED DOCUMENT FOR AMP INCORPORATED. IT IS SUBJECT TO CHANGE AND THE CONTROLLING ENGINEERING ORGANIZATION SHOULD BE CONTACTED FOR THE LATEST REVISION. | MATERIAL COPPER ASTM B-152 PVC: COLOR - YELLOW | FINISH TIN PLATE PER ASTM B545 | APPLICATION SPEC 114-2161 | SIZE A3 | CAGE CODE 00779 | DRAWING NO C-34853 | RESTRICTED TO - |
| | | | | | WEIGHT - | SCALE 4:1 | | SHEET 1 OF 1 | REV L2 |

X-ON Electronics

Largest Supplier of Electrical and Electronic Components

Click to view similar products for [Terminals](#) category:

Click to view products by [TE Connectivity](#) manufacturer:

Other Similar products are found below :

[00-054007-01074-6](#) [00-054007-70206-1](#) [00-054007-70210-8](#) [00-054007-70217-7](#) [00-054007-70226-9](#) [00-054007-70228-3](#) [00-054007-70248-1](#) [00-054007-70256-6](#) [00-054007-70301-3](#) [00-054007-70316-7](#) [00-054007-49560-4](#) [00-054007-70209-2](#) [00-054007-70225-2](#) [00-054007-70227-6](#) [00-054007-70231-3](#) [00-054007-70241-2](#) [00-054007-70242-9](#) [00-054007-70244-3](#) [00-054007-70246-7](#) [00-054007-70263-4](#) [00-054007-70288-7](#) [00-054007-70290-0](#) [00-054007-70300-6](#) [00-054007-70304-4](#) [01-2065-1-0216](#) [01-2900-1-04412](#) [00581P0075](#) [600TS-10](#) [60205-1](#) [604200-1](#) [605601-1](#) [60598-1-CUT-TAPE](#) [61314-6-C](#) [61810-3](#) [61-S](#) [61-SN](#) [626-0194](#) [62-NBM-A](#) [62-SN](#) [62-SP](#) [63-S](#) [640179-1](#) [M55155/059I03](#) [M55155/079C01](#) [M55155/099H02](#) [M55155/109H01](#) [M55155/109H02](#) [M55155/12XH05](#) [M55155/16XH02](#) [M55155/29-5S](#)