

REVISIONS		DATE	BY	APP.
01	INITIAL REVISION			

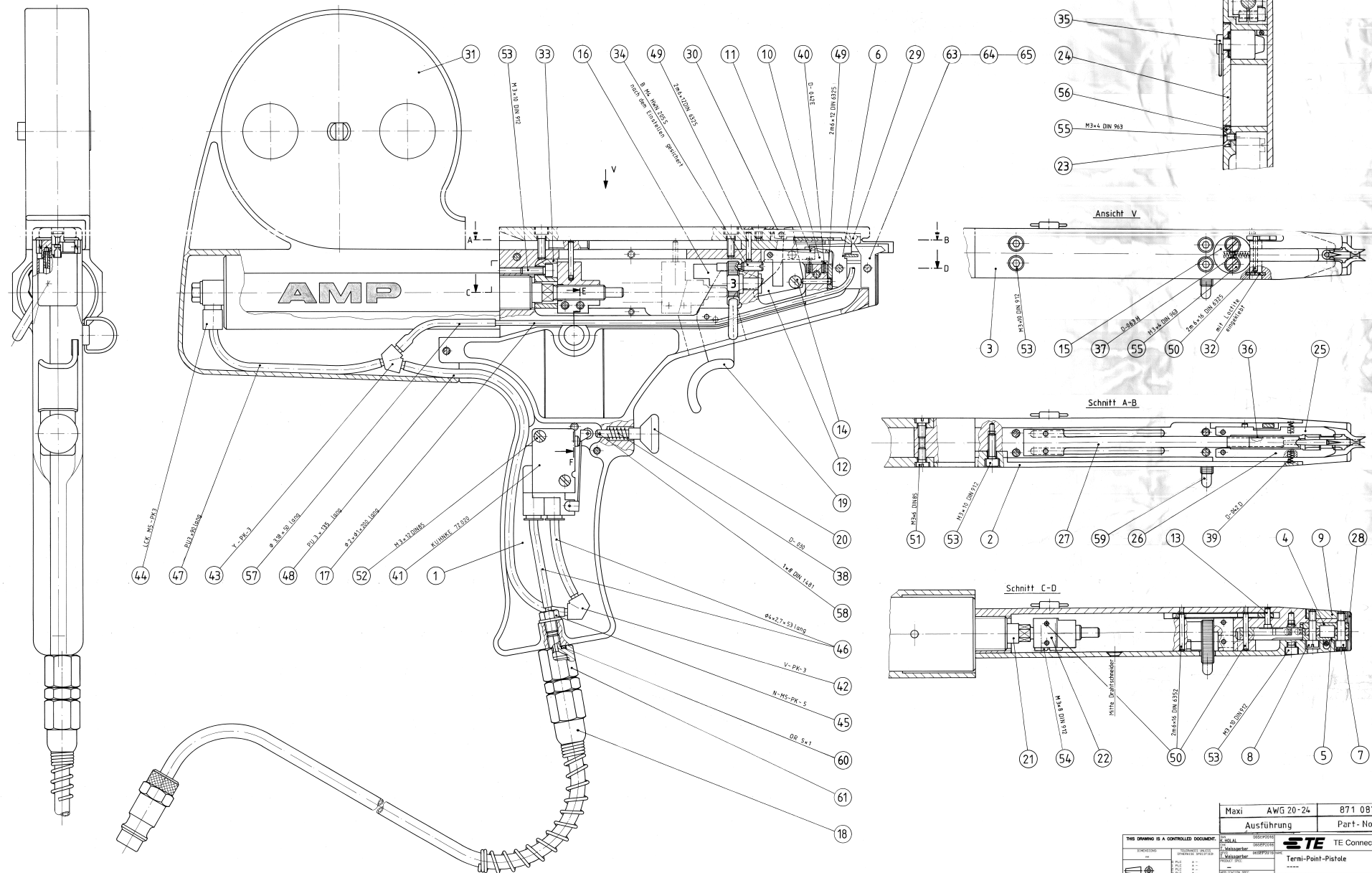

Maxi	AWG 20-24	871 087-1	D
Ausführung		Part-No	Rev

THIS DRAWING IS A CONTROLLED DOCUMENT:		TE Connectivity Termi-Point-Pistole	
APPROVED BY: _____ DATE: _____ DRAWN BY: _____ DATE: _____	PART NO: 871087-1 REV: 00779	CONTROLLED BY: _____ DATE: _____	CUSTOMER DRAWING

9	1	0-0871299-1	A	BEFESTIGUNGSKEIL	<input checked="" type="checkbox"/>	<input type="checkbox"/>
10	1	0-0871300-1	A	VORLAUFSPERRE	<input checked="" type="checkbox"/>	<input checked="" type="checkbox"/>
11	1	0-0871301-1	A	RÜCKLAUFSPERRE	<input checked="" type="checkbox"/>	<input checked="" type="checkbox"/>
12	1	0-0871302-1	A1	UMLENKHEBEL	<input checked="" type="checkbox"/>	<input type="checkbox"/>
13	1	0-0871303-1	A	BUNDBOLZEN	<input checked="" type="checkbox"/>	<input type="checkbox"/>
14	1	0-0871304-1	A	GEWINDEBOLZEN	<input checked="" type="checkbox"/>	<input type="checkbox"/>
15	1	0-0871305-1	A	DECKEL	<input checked="" type="checkbox"/>	<input type="checkbox"/>
16	1	0-0871306-1	B	ANSCHLAGWÄHLSCHEIBE	<input checked="" type="checkbox"/>	<input type="checkbox"/>
17	1	0-2030758-8	C	TUBING, CLEAR, 1.2ID KUNSTSTOFFSCHLAUCH, TRANSPA	<input checked="" type="checkbox"/>	<input type="checkbox"/>
18	1	0-0871308-1	B	ANSCHLUßSCHLAUCH KPL.	<input checked="" type="checkbox"/>	<input type="checkbox"/>
19	1	0-0871309-1	A	HEBEL	<input checked="" type="checkbox"/>	<input type="checkbox"/>
20	1	0-0871310-1	B	VENTILAUSLÖSER	<input checked="" type="checkbox"/>	<input type="checkbox"/>
21	1	0-0871311-1	D	PNEUM.-ZYLINDER Ø25*48 HUB EINFACHW.	<input checked="" type="checkbox"/>	<input type="checkbox"/>
22	1	0-0871312-1	C	KOLBENSTANGENKOPF	<input checked="" type="checkbox"/>	<input type="checkbox"/>
23	1	0-0871313-1	A	SCHARNIER	<input checked="" type="checkbox"/>	<input type="checkbox"/>
24	1	0-0871314-1	A	FENSTER	<input checked="" type="checkbox"/>	<input type="checkbox"/>
25	1	0-0871315-1	C1	PFOSTENFÜHRUNG LINKS	<input checked="" type="checkbox"/>	<input checked="" type="checkbox"/>
26	1	0-0871316-1	C1	PFOSTENFÜHRUNG RECHTS	<input checked="" type="checkbox"/>	<input checked="" type="checkbox"/>

REMARKS: AUSFÜHRUNG FÜR AWG 20 - 24. FÜR SCHALTDRAHT ODER LITZE 7-ADRIG.



USED ON

P	LTR	REVISION RECORD	DATE	DWN	APVD	PRINTED	DWN	28SEP92	CHK	APVD	
-	D1	SEE SHEET 1	-	-	-	06SEP16	KREUZER	-	-	-	
-	-	-	-	-	-	WEIGHT	DIMENSION (mm)	MATERIAL	HT TR	-	
-	-	-	-	-	-	-	-	-	-	-	
-	-	-	-	-	-			TE Connectivity SPARE AND WEAR PARTS LIST			
THIS DRAWING IS A CONTROLLED DOCUMENT FOR TYCO ELECTRONICS CORPORATION. IT IS SUBJECT TO CHANGE AND THE CONTROLLING ENGINEERING ORGANIZATION SHOULD BE CONTACTED FOR THE LATEST REVISION. DIESES ZEICHNUNGSDOKUMENT WIRD DURCH TYCO ELECTRONICS CORPORATION KONTROLLIERT. ÄNDERUNGEN DIE DEM TECHNISCHEN FORTSCHRITT DIENEN, SIND VORBEHALTEN. DEN JEWEILS LETZTGÜLTIGEN ÄNDERUNGSSTAND ERFAHREN SIE AUF ANFRAGE.						TOLERANCES UNLESS OTHERWISE SPECIFIED SEE SHEET 1				RESTRICTED TO	
						NAME TERMI-POINT-PISTOLE MAXI					
			SCALE SEE SHEET 1		SIZE A4	DRAWING NO C-871087-1		SHEET 2/4	REV D1		

35	1	0-0871325-1	A	SCHNELLVERSCHLUSS	<input checked="" type="checkbox"/>	<input type="checkbox"/>
36	1	0-0871326-1	B	VORSCHUBFEDER	<input checked="" type="checkbox"/>	<input checked="" type="checkbox"/>
37	1	9-0653861-9	A	PRESSURE SPRING DRUCKFEDER	<input checked="" type="checkbox"/>	<input checked="" type="checkbox"/>
38	1	3-0653861-4	A	PRESSURE SPRING DRUCKFEDER	<input checked="" type="checkbox"/>	<input checked="" type="checkbox"/>
39	2	9-0653861-8	A	PRESSURE SPRING DRUCKFEDER	<input checked="" type="checkbox"/>	<input checked="" type="checkbox"/>
40	2	3-0659650-4	A	PRESSURE SPRING DRUCKFEDER	<input checked="" type="checkbox"/>	<input type="checkbox"/>
41	1	0-2030375-1	A	VALVE MICRO-STÖßELVENTIL S-3-PK3-B	<input checked="" type="checkbox"/>	<input checked="" type="checkbox"/>
42	1	0-2256816-1	A	CONNECTOR, VEE, TUBE L-PK-3	<input checked="" type="checkbox"/>	<input type="checkbox"/>
43	1	0-0993844-1	O	CONNECTOR SCHLAUCHVERBINDUNG Y-PK-3	<input checked="" type="checkbox"/>	<input type="checkbox"/>
44	1	0-2079044-1	A	CONNECTOR, ELBOW SCHNELLVERSCHR. LCK-M5-PK-3	<input checked="" type="checkbox"/>	<input type="checkbox"/>
45	1	0-2030331-1	A	CONNECTOR, BARRED STECKNIPPEL N-M5-PK-3	<input checked="" type="checkbox"/>	<input type="checkbox"/>
46	2	1-0658455-2	O	RILSAN ROHR Ø4*2,7*53 LANG	<input checked="" type="checkbox"/>	<input type="checkbox"/>
47	2	0-0657583-4	A	KUNSTSTOFFSCHLAUCH PU-3	<input checked="" type="checkbox"/>	<input type="checkbox"/>
49	3	3-0992946-9	S	PIN, DOWEL, METRIC	<input checked="" type="checkbox"/>	<input type="checkbox"/>
50	5	5-0992946-9	AG	PIN, DOWEL, METRIC	<input checked="" type="checkbox"/>	<input type="checkbox"/>
51	2	2-0519003-2	O	ZYLINDERSCHR. M3*6 DIN 84 -8.8 GAL NI	<input checked="" type="checkbox"/>	<input type="checkbox"/>
52	2	2-0519003-5	O	ZYLINDERSCHR. M3*12 DIN 84 -8.8 GAL NI	<input checked="" type="checkbox"/>	<input type="checkbox"/>
53	8	1-0519000-3	A	SCREW, CAP, SOCKET HD, METRIC	<input checked="" type="checkbox"/>	<input type="checkbox"/>

REMARKS: AUSFÜHRUNG FÜR AWG 20 - 24. FÜR SCHALTDRAHT ODER LITZE 7-ADRIG.



USED ON

P	LTR	REVISION RECORD	DATE	DWN	APVD	PRINTED	DWN	28SEP92	CHK	APVD	
-	D1	SEE SHEET 1	-	-	-	06SEP16	KREUZER	-	-	-	
-	-	-	-	-	-	WEIGHT	DIMENSION (mm)	MATERIAL	HT TR	-	
-	-	-	-	-	-	-	-	-	-	-	
-	-	-	-	-	-	 TOLERANCES UNLESS OTHERWISE SPECIFIED SEE SHEET 1		 TE Connectivity			
THIS DRAWING IS A CONTROLLED DOCUMENT FOR TYCO ELECTRONICS CORPORATION. IT IS SUBJECT TO CHANGE AND THE CONTROLLING ENGINEERING ORGANIZATION SHOULD BE CONTACTED FOR THE LATEST REVISION.							SPARE AND WEAR PARTS LIST				
DIESES ZEICHNUNGSDOKUMENT WIRD DURCH TYCO ELECTRONICS CORPORATION KONTROLLIERT. ÄNDERUNGEN DIE DEM TECHNISCHEN FORTSCHRITT DIENEN, SIND VORBEHALTEN. DEN JEWEILS LETZTGÜLTIGEN ÄNDERUNGSSTAND ERFAHREN SIE AUF ANFRAGE							NAME TERMI-POINT-PISTOLE MAXI			RESTRICTED TO	
SCALE SEE SHEET 1			SIZE A4		DRAWING NO C-871087-1			SHEET 3/4	REV D1		

63	0	0-0871295-1	A	MANDREL AWG 20 ABISOLIEREINSATZ	<input checked="" type="checkbox"/>	<input checked="" type="checkbox"/>
64	0	0-0871295-2	A	MANDREL AWG 24 ABISOLIEREINSATZ	<input checked="" type="checkbox"/>	<input checked="" type="checkbox"/>
67	0	0-0871330-1	A	DRAHTABSCHNEIDER	<input checked="" type="checkbox"/>	<input type="checkbox"/>
68	0	0-0871331-1	A	BALANCERHALTER KPL.	<input checked="" type="checkbox"/>	<input type="checkbox"/>

REMARKS: AUSFÜHRUNG FÜR AWG 20 - 24. FÜR SCHALTDRAHT ODER LITZE 7-ADRIG.

USED ON

P	LTR	REVISION RECORD	DATE	DWN	APVD	PRINTED	DWN	28SEP92	CHK	APVD
-	D1	SEE SHEET 1	-	-	-	06SEP16	KREUZER	-	-	-
-	-	-	-	-	-	WEIGHT	DIMENSION (mm)	MATERIAL	HT TR	-
-	-	-	-	-	-	-	-	-	-	-
-	-	-	-	-	-	-	-	-	-	-
<p>THIS DRAWING IS A CONTROLLED DOCUMENT FOR TYCO ELECTRONICS CORPORATION. IT IS SUBJECT TO CHANGE AND THE CONTROLLING ENGINEERING ORGANIZATION SHOULD BE CONTACTED FOR THE LATEST REVISION.</p> <p>DIESES ZEICHNUNGSDOKUMENT WIRD DURCH TYCO ELECTRONICS CORPORATION KONTROLLIERT. ÄNDERUNGEN DIE DEM TECHNISCHEN FORTSCHRITT DIENEN, SIND VORBEHALTEN. DEN JEWEILS LETZTGÜLTIGEN ÄNDERUNGSSTAND ERFAHREN SIE AUF ANFRAGE</p>						 <p>TOLERANCES UNLESS OTHERWISE SPECIFIED SEE SHEET 1</p>		 <p>TE Connectivity</p>		
						<p>SPARE AND WEAR PARTS LIST</p>				
<p>NAME TERMI-POINT-PISTOLE MAXI</p>									<p>RESTRICTED TO</p>	
<p>SCALE SEE SHEET 1</p>			<p>SIZE A4</p>		<p>DRAWING NO C-871087-1</p>				<p>SHEET 4/4</p>	<p>REV D1</p>

X-ON Electronics

Largest Supplier of Electrical and Electronic Components

Click to view similar products for [Hand Tools](#) category:

Click to view products by [TE Connectivity](#) manufacturer:

Other Similar products are found below :

[568681-1](#) [576786-2](#) [58061-1](#) [58176-1](#) [58177-1](#) [58177-2](#) [58284-1](#) [59085](#) [0031](#) [59737-5](#) [015-0339-000](#) [015-8755-001](#) [600-146-06](#) [M15570-25](#) [62200-5709](#) [6-304052-1](#) [63443-1002](#) [63443-3513](#) [63443-4025](#) [63443-7114](#) [6-354778-5](#) [6-354779-2](#) [63600-2995](#) [63810-0105](#) [M8196914-08](#) [M819698-07](#) [662508-1](#) [662908-1](#) [679994-1](#) [679994-2](#) [68764-0001](#) [69001-0105](#) [69002-5525](#) [690124-7](#) [690191-1](#) [690191-4](#) [690696-1](#) [691409-4](#) [691667-1](#) [692006-2](#) [692655-7](#) [692776-1](#) [692776-4](#) [693077-3](#) [693077-4](#) [693597-1](#) [D20418-137](#) [D20419-189](#) [ESR-17x17](#) [ET-LY10](#)