

SPECIFICATION CONTROL DRAWING

55FA0511

TITLE	CABLE, ELECTRIC, FILTER LINE - ELECTROLOSS, COMPONENT WIRE	Date	7-23-10	Revision	J
This specification sheet forms a part of the latest issue of Raychem Specification 55F.					

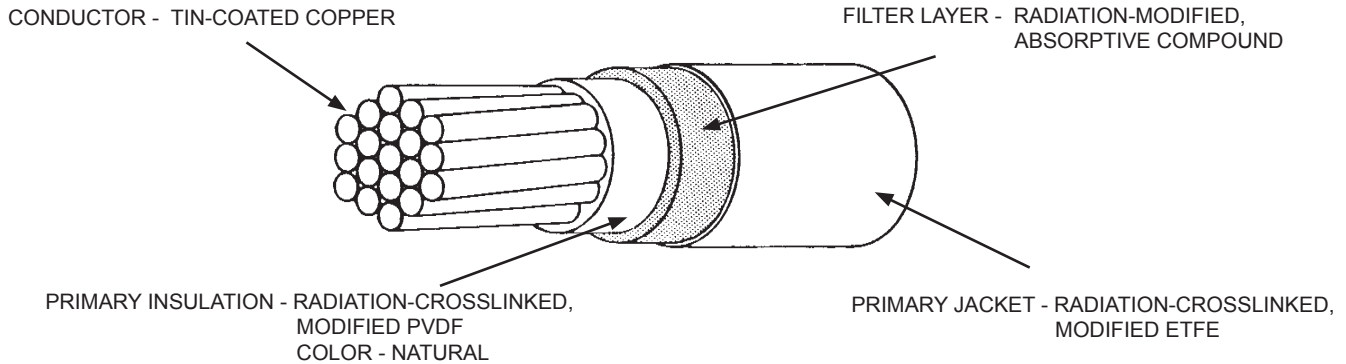

TABLE I. CONSTRUCTION DETAILS

PART NUMBER 1/	WIRE SIZE (AWG)	CONDUCTOR STRANDING (number x AWG)	DIAMETER OF STRANDED CONDUCTOR (in.)		FINISHED WIRE		
			MINIMUM	MAXIMUM	MAXIMUM RESISTANCE AT 20°C (ohms/1000 ft)	DIAMETER (in.)	MAXIMUM WEIGHT (lbs/1000 ft.)
55FA0511-22-*	22	19 x 34	.029	.033	16.2	.051 ± .003	4.0
55FA0511-20-*	20	19 x 32	.037	.041	9.88	.059 ± .003	5.8
55FA0511-18-*	18	19 x 30	.046	.051	6.23	.070 ± .003	8.7
55FA0511-16-*	16	19 x 29	.052	.058	4.81	.078 ± .004	11.2
55FA0511-14-*	14	19 x 27	.065	.073	3.06	.095 ± .004	16.1
55FA0511-12-*	12	37 x 28	.084	.090	2.02	.112 ± .004	24.0
55FA0511-10-*	10	37 x 26	.106	.114	1.26	.136 ± .005	37.0

TABLE II. PERFORMANCE DETAILS

PART NUMBER 1/	BEND TESTING			
	MANDREL DIAMETER (inch) (± 3%)		WEIGHT (lb) (± 3%)	
	IMMERSION, LIFE CYCLE AND CROSSLINKING PROOF TEST	COLD BEND	IMMERSION, LIFE CYCLE AND CROSSLINKING PROOF TEST	COLD BEND
55FA0511-22-*	.500	2.00	.750	3.00
55FA0511-20-*	.750	2.50	1.25	4.00
55FA0511-18-*	1.00	3.00	1.75	4.00
55FA0511-16-*	1.00	3.00	2.00	5.00
55FA0511-14-*	1.00	5.00	2.00	5.00
55FA0511-12-*	1.50	6.00	2.50	5.00
55FA0511-10-*	1.50	8.00	2.50	5.00

This product meets or exceeds all requirements of SAE AS85485/9, less identification, for AWG's 22-10. All other AWG sizes meet or exceed requirements of SAE AS85485, less identification.

Users should evaluate the suitability of this product for their application. Specifications are subject to change without notice. Tyco Electronics also reserves the right to make changes in materials or processing, which do not affect compliance with any specification, without notification to Buyer.

1/ COLORS AND COLOR CODE DESIGNATORS SHALL BE IN ACCORDANCE WITH MIL-STD-681. OTHER CODES AND SUFFIXES MAY BE ADDED TO THE PART NUMBER. AS NECESSARY, TO CAPTURE ANY ADDITIONAL REQUIREMENTS IMPOSED BY THE PURCHASE ORDER.

Page 1 of 3	The TE logo, Tyco Electronics, Electroloss and Raychem are trademarks.		Raychem Wire & Cable 501 Oakside Avenue Redwood City, CA 94063-3800 Phone: 1-800-227-8816 Fax: 1-650-361-6297
	DIMENSIONS ARE IN INCHES, AND UNLESS OTHERWISE DESIGNATED ARE NOMINAL		
	THIS SPECIFICATION SHEET TAKES PRECEDENCE OVER DOCUMENTS REFERENCED HEREIN. REFERENCED DOCUMENTS SHALL BE OF THE ISSUE IN EFFECT ON DATE OF INVITATION FOR BID.		

	SPECIFICATION CONTROL DRAWING	Page 2 of 3	Revision J	SCD Number 55FA0511
---	--------------------------------------	-------------	---------------	-------------------------------

WIRE RATINGS AND ADDITIONAL REQUIREMENTS

TEMPERATURE RATING: 150°C

Maximum continuous conductor temperature

VOLTAGE RATING: 600 volts (rms) at sea level

ATTENUATION (INSERTION LOSS): See Table III

BLOCKING: 200 ± 3°C for 6 hours

COLOR: Light violet preferred

CONCENTRICITY: Primary Insulation - 50% (minimum); Finished Wire - 70% (minimum)

CROSSLINKING PROOF TEST: 300 ± 3°C for 7 hours

FLAMMABILITY: 3 seconds (maximum); 3 in. (maximum); no flaming of facial tissue

FLUORIDE EXTRACTION: 70 ± 2°C for 168 hours, 150 ppm (maximum)

HUMIDITY RESISTANCE: Insulation Resistance, 5000 megohms for 1000 ft. (minimum)

IDENTIFICATION AND COLOR STRIPING DURABILITY:

125 cycles (250 strokes) (minimum), 500 g weight

IMMERSION: Diameter increase 5% (maximum); no cracking, no dielectric breakdown

INSULATION ELONGATION AND TENSILE STRENGTH:

Primary Insulation, Filter Layer and Primary Jacket pulled together

Elongation, 50% (minimum)

Tensile Strength, 3000 lbf/in² (minimum)

INSULATION FLAWS:

Primary Insulation only,

Spark Test, 1.5 kV (rms) at 60 Hz

4.2 kV (rms) at 3 kHz

Impulse Dielectric Test, 6.0 kV (peak)

Finished Wire,

Spark Test, 3.0 kV (rms) at 60 Hz

5.7 kV (rms) at 3 kHz

Impulse Dielectric Test, 8.0 kV (peak)

INSULATION RESISTANCE: 5000 megohms for 1000 ft. (minimum)

INSULATION THICKNESS:

Primary Insulation, .002 in. (minimum);

Filter Layer, average .0025 in. (minimum);

Primary Jacket, .0035 in. (minimum)

LIFE CYCLE: 200 ± 3°C for 168 hours

LOW TEMPERATURE-COLD BEND: -65 ± 2°C for 4 hours

SHRINKAGE: 200 ± 3°C for 6 hours, 0.125 in. (maximum)

SMOKE: 200 ± 2°C, no visible smoke

SURFACE RESISTANCE: 500 megohms-in. (minimum), initial and final readings

THERMAL SHOCK RESISTANCE: 150 ± 3°C, .060 in. (maximum)

THERMAL STABILITY: 180 ± 3°C for 1250 hours

VOLTAGE WITHSTAND (Post Environmental): 1500 volts (rms), 60 Hz

WRAP TEST: 200 ± 3°C for 6 hours, no cracking

PART NUMBER:

The "*" in the part numbers in Tables I-III shall be replaced by a color code designator, except that violet shall be light violet and designator shall be 7L.

1/ Example: AWG 20, light violet: 55FA0511-20-7L

AWG 20, light violet with blue stripe: 55FA0511-20-7L6

1/ See footer section on page 1

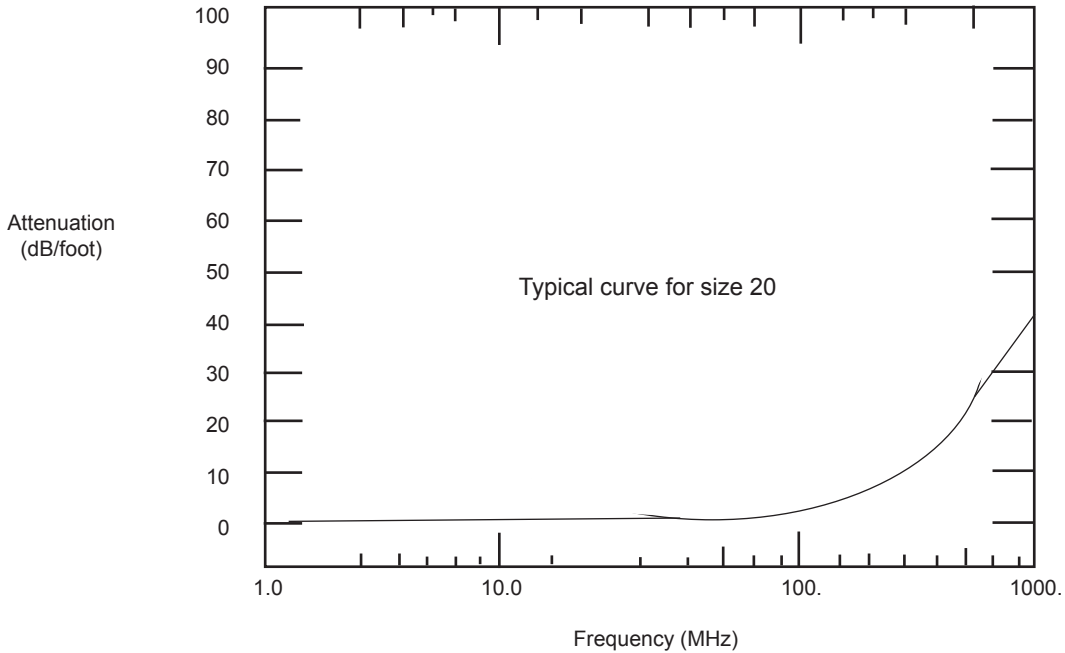

ATTENUATION (INSERTION LOSS)

TABLE III. ATTENUATION (INSERTION LOSS) +							
PART NUMBER 1/	PASS BAND (dB/ft.)			TRANSITION BAND (dB/ft.)			STOP BAND (dB/ft.)
	1.0 MHz	10.0 MHz		100 MHz	500 MHz	1000 MHz	1 to 12 GHz
	(max)	(min)	(max)	(min)	(min)	(min)	(min)
55FA0511-22-*	.02	.06	0.20	1.3	12	30	30
55FA0511-20-*	.02	.06	0.20	1.3	12	30	30
55FA0511-18-*	.02	.06	0.20	1.3	13	33	33
55FA0511-16-*	.02	.06	0.20	1.3	13	33	33
55FA0511-14-*	.02	.06	0.20	1.3	13	33	33
55FA0511-12-*	.02	.04	0.20	1.3	12	30	30
55FA0511-10-*	.02	.04	0.20	1.3	12	30	30

1/ See footer section on page 1

+ THE PRIMARY WIRE OF THIS SPECIFICATION SHEET SHALL MEET THE ATTENUATION REQUIREMENTS SHOWN ABOVE ONLY WHEN USED AS A SINGLE COMPONENT IN A SHIELDED CABLE.

X-ON Electronics

Largest Supplier of Electrical and Electronic Components

Click to view similar products for [Hook-up Wire](#) category:

Click to view products by [TE Connectivity](#) manufacturer:

Other Similar products are found below :

[8918-BRN-1000](#) [8920-DK-BLU-1000](#) [CR6328-000](#) [01776.38.01](#) [M22759/16-14-5-500FT](#) [7053-RED-1000](#) [7053-SLATE-1000](#) [F25935-000](#)
[F60898-000](#) [8055](#) [81044/12-18-9CS3209](#) [82A0811-4-9-G110](#) [83004-ORG-1000](#) [83005-LT-BLU-1000](#) [83025-VIO-1000](#) [8523-RED-100](#)
[8524-WHT-100](#) [8525-ORG-1000](#) [8530-BLK-1000](#) [8530-LT-BLU-100](#) [8538-009-1000](#) [8597-LT-BLU-100](#) [8898-BLK-100](#) [138498-000](#)
[E76065-000](#) [EPD50886A-20-9](#) [BFWUL3239-24-PINK](#) [C2015A.12.04](#) [C2015A.12.05](#) [C2015A.12.08](#) [C2015A.12.10](#) [C2015A.12.19](#)
[C2016A.12.05](#) [C2016A.12.07](#) [C2065A.12.02](#) [C77653-000](#) [220368-001](#) [8916-GRY-500](#) [8918-RED-100](#) [8919-DK-BLU-1000](#) [8919-YEL-100](#)
[8920-YEL-100](#) [9242833001](#) [933205-000](#) [282257-000](#) [2841/7-YELLOW-1000](#) [2842/7-ORANGE-100](#) [2842/7-RED-1000](#) [2843/19-BLUE-100](#)
[2843/1-YELLOW-100](#)