

REVISIONS			
NO.	DATE	BY	APPD.
B15	ECR-15-014318	29SEP2015	VH SCH
B16	NOTE ON DIM MAX. 0.2 CHANGED	06.AUG.2016	MO. SCHI
B17	ECR-17-019996, NEW PNs CREATED	0202.12017	MB PSI
B18	ECR-20-015852, NEW PNs ADDED	23SEP2020	JMK PM

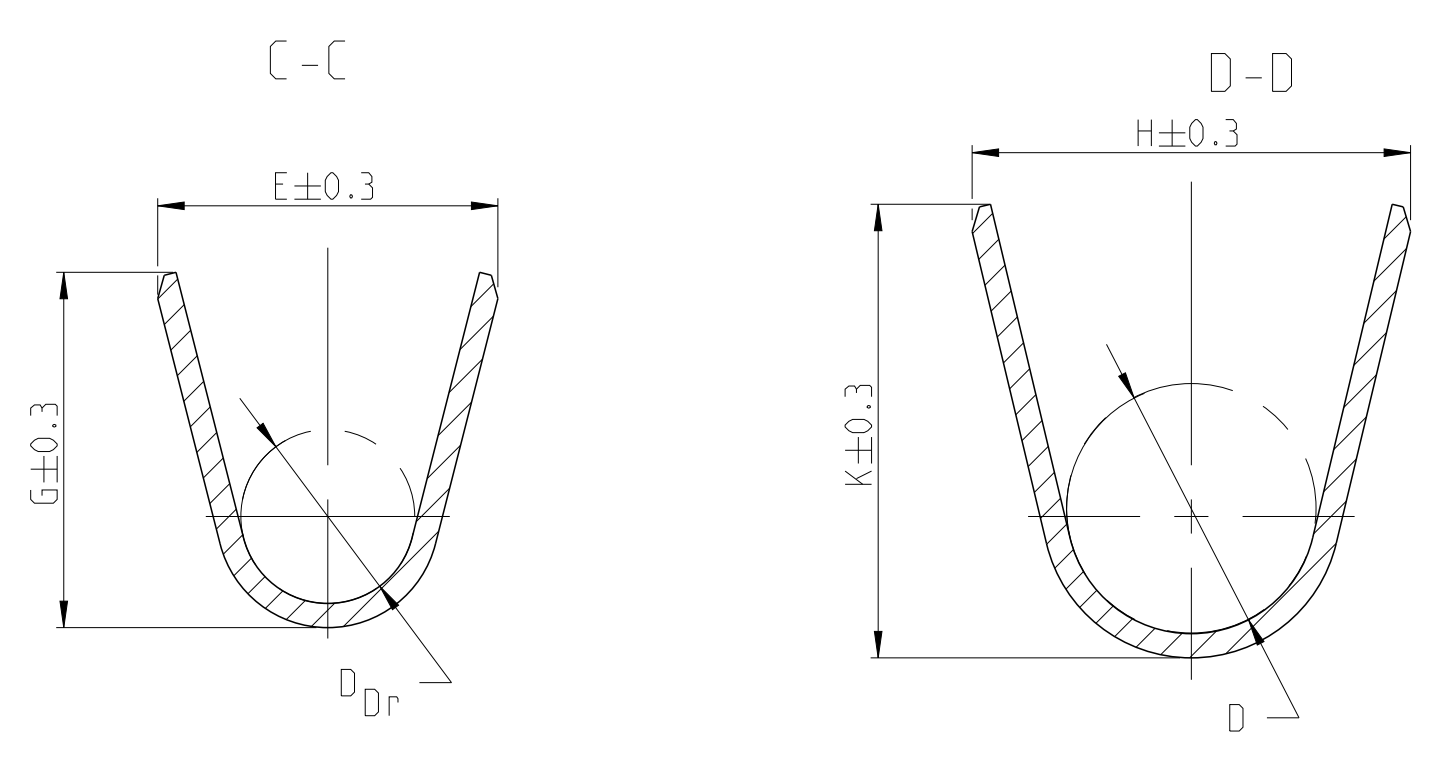

FLR-WIRE
FLR-Leitung

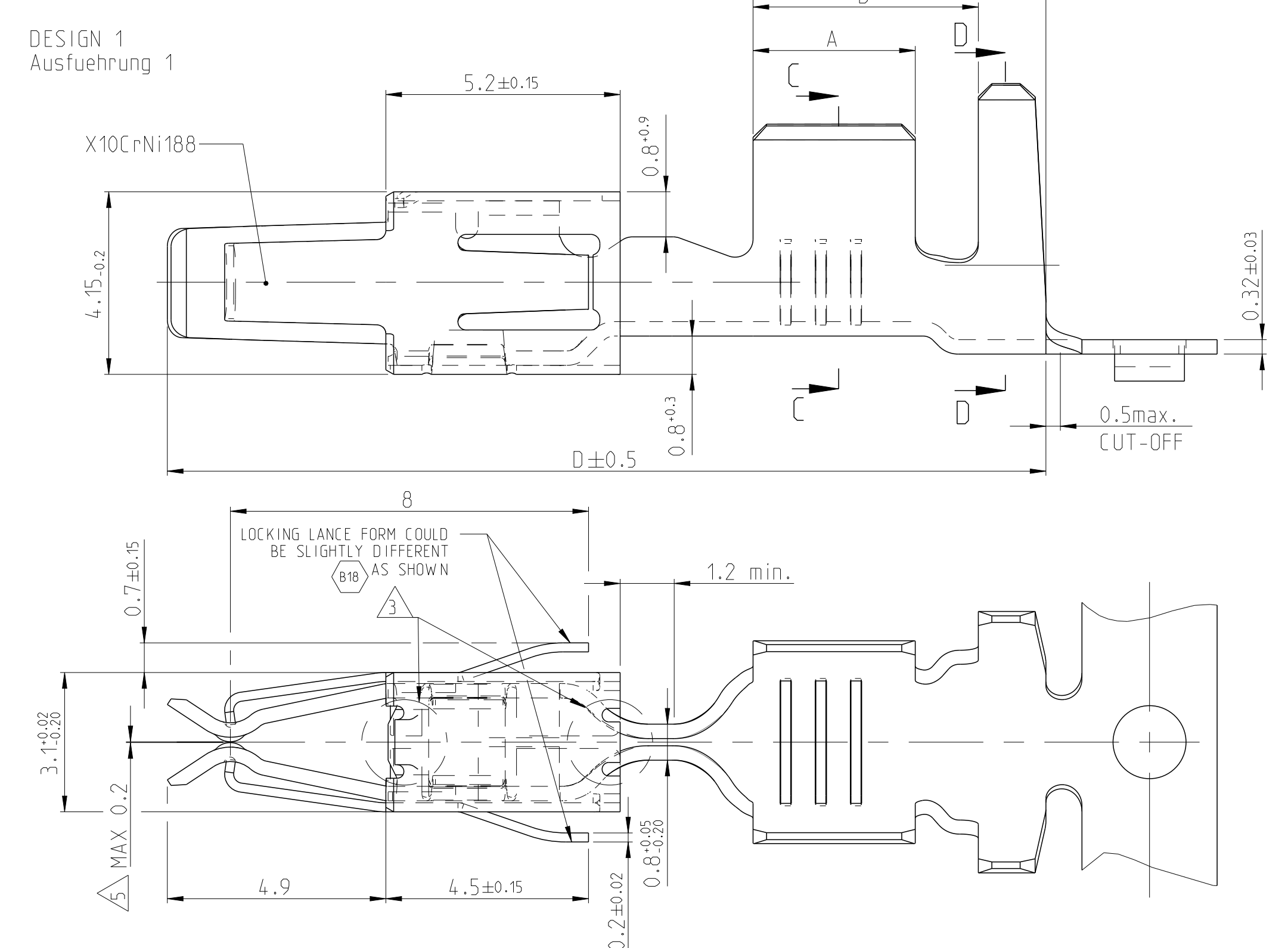

FLR- AND FLK-CABLE
FLR- und FLK- Leitung

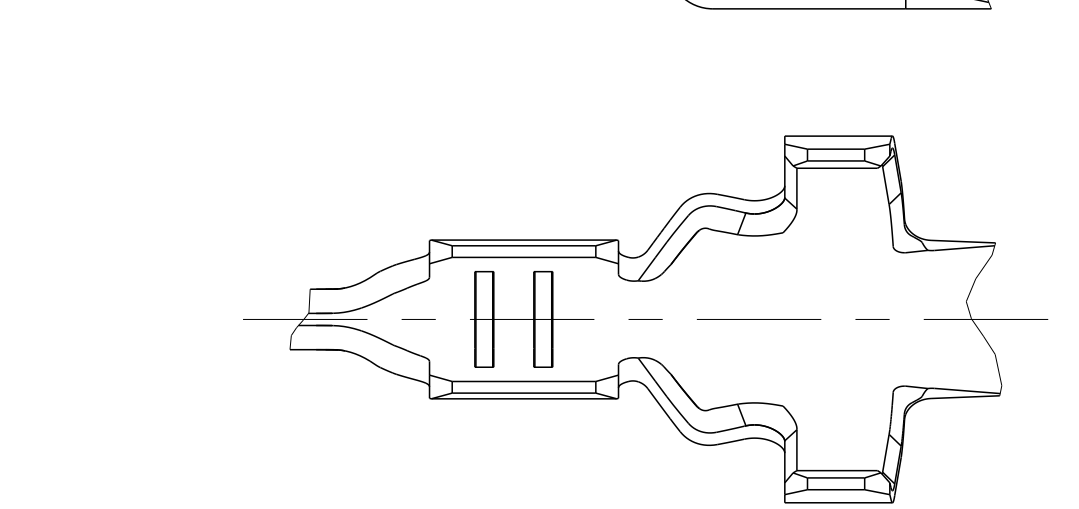
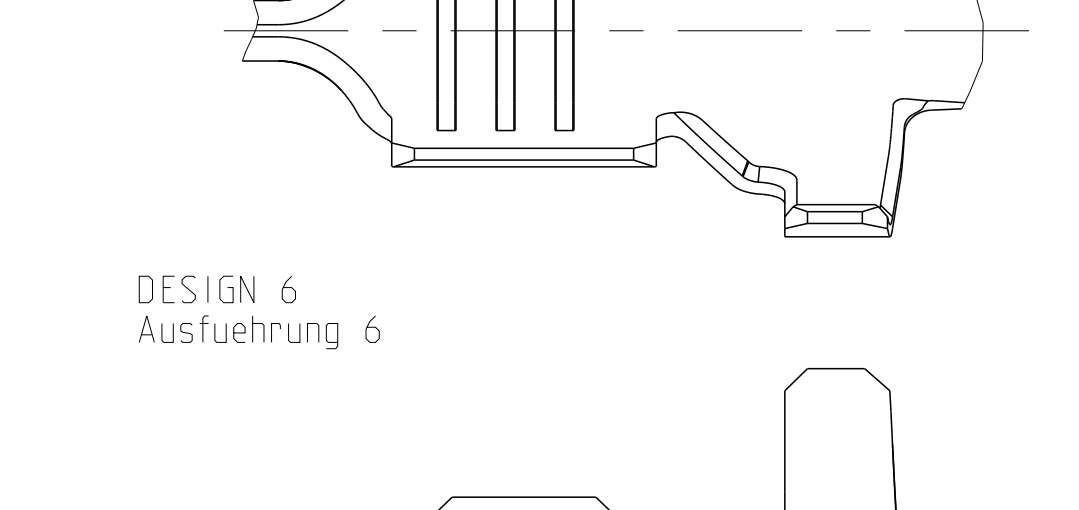
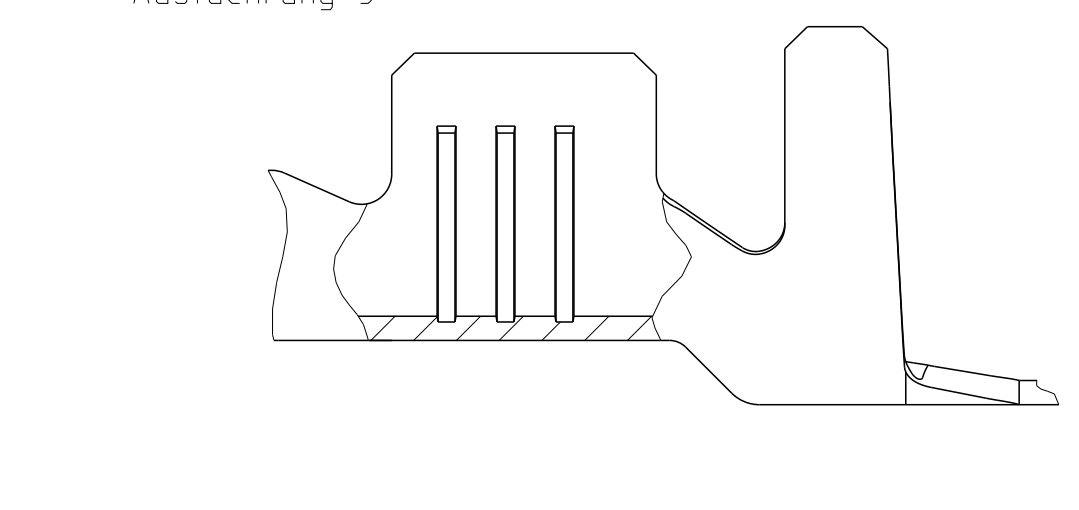
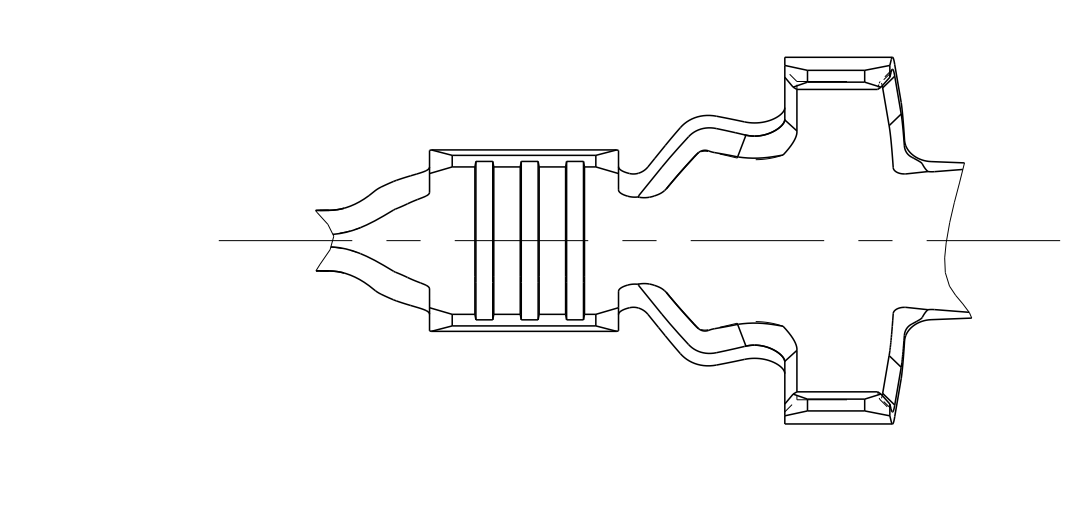
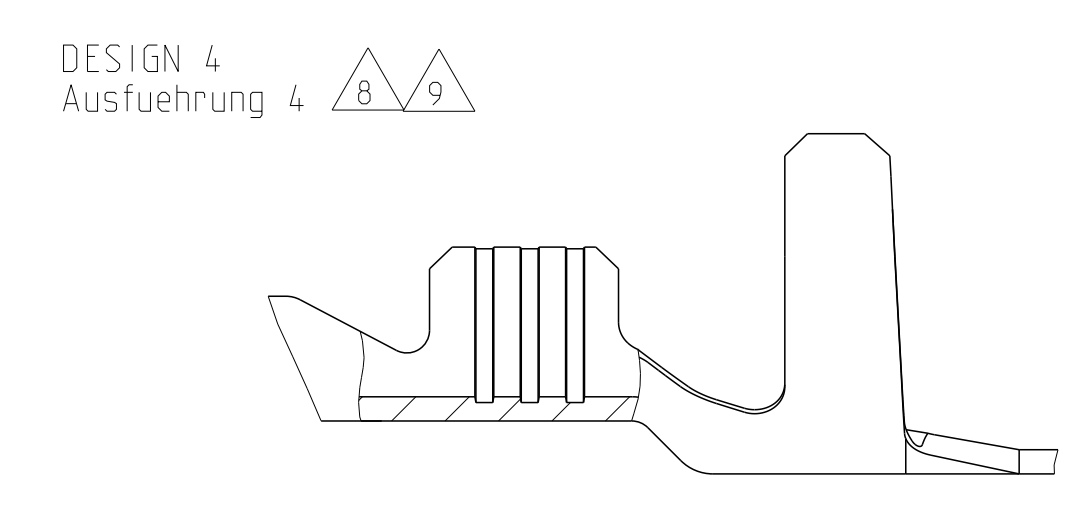

TE ORDER NO. STRIP FORM Bandware	REV.	DESIGN Ausführung	MATERIAL Werkstoff	SURFACE Oberfläche	WIRE RANGE Drahtgrößen Bereich [mm²]	INSULATION Isolations Ø [mm]	WIRE CRIMP Drahtcrimp Bandware	INSUL.-CRIMP Iso.-Crimp Bandware	A	B	C	D	CRIMP DATA AND CRIMP TOOL Crimpdataen u. Crimptwerkzeuge			
													E	G	K	D
1241978-2	A	1	CuSn4	PRET INNED vorverzinkt	×2.5-4.0	2.7-3.7	E = 4.5 G = 4.7 DDr = 2.3	H = 5.8 K = 6.0 D = 3.3	3.6	5.0	6.5	19.5				
1241978-1	A		CuFe2	PRET INNED vorverzinkt												
4-965999-1	F		CuNiSi	△												
2-965999-1	F		CuSn4	△												
965999-6	A	1	CuSn4	△	×1.0-2.5	2.2-3.0	E = 3.6 G = 3.8 DDr = 1.8	H = 4.7 K = 4.9 D = 2.6	3.3	4.3	5.8	18.8				
965999-2	F		CuSn4	PRET INNED vorverzinkt												
965999-1	F		CuFe2	PRET INNED vorverzinkt												
4-964284-1	F		CuNiSi	△												
2-964284-1	F		CuSn4	△												
964284-6	A	1	CuSn4	△	0.5-1.0	1.4-2.1	E = 2.5 G = 2.7 DDr = 1.2	H = 3.7 K = 3.9 D = 1.8	3.0	4.0	5.5	18.8				
964284-2	F		CuSn4	PRET INNED vorverzinkt												
964284-1	F		CuFe2	PRET INNED vorverzinkt												
2-2141892-1	△ A	2	CuSn4	△	0.35	1.2-1.3	E = 2.4 G = 2.3 DDr = 1.0	H = 2.9 K = 2.9 D = 1.4	2.5	3.5	5.6	18.8				
2141892-2	△ A		CuSn4	PRET INNED vorverzinkt												
2-964280-1	F		CuSn4	△												
964280-6	F	3	CuSn4	△	0.2-0.5	1.15-1.6	E = 2.1 G = 2.1 DDr = 0.8	H = 2.7 K = 2.8 D = 1.4	2.5	3.5	5.6	18.8				
964280-2	F		CuSn4	PRET INNED vorverzinkt												
964280-1	F		CuFe2	PRET INNED vorverzinkt												
2-1564326-1	A	4	CuSn4	△/△	0.35	1.2-1.3	E = 2.4 G = 2.3 DDr = 1.0	H = 4.05 K = 4.5 D = 3.2	2.5	4.7	6.3	19.55				
1241872-6	△ A	5	CuSn4	△	×1.0-2.5	2.2-3.0	E = 3.6 G = 3.8 DDr = 1.8	H = 5.3 K = 5.0 D = 3.5	3.5	5.2	6.8	19.55				
1241872-1	△ A		CuFe2	PRET INNED vorverzinkt												
1241868-6	△ A	5	CuSn4	△	0.5-1.0	1.4-2.7	E = 2.5 G = 2.7 DDr = 1.2	H = 5.1 K = 4.8 D = 3.3	3.0	4.7	6.3	19.55				
1241868-1	△ A		CuFe2	PRET INNED vorverzinkt												
4-1241864-1	△ A	6	CuNiSi	△	0.2-0.5	1.2-2.3	E = 2.1 G = 2.1 DDr = 0.8	H = 4.7 K = 4.5 D = 3.2	2.5	4.7	6.3	19.55				
6-964273-6	F		CuSn4	△/△												
3-964273-1	F		CuNiSi	△												
2-964273-1	F	5	CuSn4	△	×1.0-2.5	2.2-3.0	E = 3.6 G = 3.8 DDr = 1.8	H = 5.3 K = 5.0 D = 3.5	3.5	5.2	6.8	19.55				
964273-2	F		CuSn4	PRET INNED vorverzinkt												
964273-1	F		CuFe2	PRET INNED vorverzinkt												
6-964286-6	F		CuSn4	△/△												
2-964286-1	F	5	CuSn4	△	×1.0-2.5	2.2-3.0	E = 3.6 G = 3.8 DDr = 1.8	H = 5.3 K = 5.0 D = 3.5	3.5	5.2	6.8	19.55				
964286-2	F		CuSn4	PRET INNED vorverzinkt												
964286-1	F		CuFe2	PRET INNED vorverzinkt												
2-2141894-1	△ A	4	CuSn4	△	0.35	1.2-1.3	E = 2.4 G = 2.3 DDr = 1.0	H = 4.85 K = 4.5 D = 3.2	2.5	4.7	6.3	19.55				
2141894-2	△ A		CuSn4	PRET INNED vorverzinkt												
6-964282-6	F		CuSn4	△/△												
2-964282-1	F	6	CuSn4	△	×1.0-2.5	2.2-3.0	E = 3.6 G = 3.8 DDr = 1.8	H = 5.3 K = 5.0 D = 3.5	3.5	5.2	6.8	19.55				
964282-2	F		CuSn4	PRET INNED vorverzinkt												
964282-1	F		CuFe2	PRET INNED vorverzinkt												

SEE APPLICATION - SPECIFICATION
siehe Anwendungsspezifikation
14-18050

- △ BODY ELECTRO TIN PLATED OVER NICKEL 0.2 µm min.
Kontaktkörper galv. verzinkt ueber Nickel 0.2 µm min.
CONTACT AREA SELECTIV GOLD OVER NICKEL 0.8 µm min.
Kontaktzone selektiv vergoldet ueber Nickel 0.8 µm min.
WIRE CRIMP AREA ELECTRO TIN PLATED 1 µm min.
Drahtcrimbereich galv. verzinkt 1 µm min.
- △ ACCORDING INSULATION DIA IS TO CHOOSE THE SINGLE WIRE SEAL
Entsprechend dem Isolationsdurchmesser ist die Einzel-Dichtung auszuwaehlen
- △ CUT OFF OPTIONAL
Optionaler Federabschnitt
- △ VARIANTS WITH GAP-SIZE 0.3mm
Varianten mit Gap-Size 0.3mm
- △ FOR EVALUATION OF THE GAP-SIZE, THE MATING-FORCE HAS PRIORITY.
Zur Beurteilung des Oeffnungsmasses ist die Steckkraft ausschlaggebend
- △ CONTACT BODY PRE-SILVER PLATED MIN. 0.8µm
CONTACT ZONE SELECTIVE PRE-SILVER PLATED MIN. 3µm
Kontaktkoerper vorversilbert min. 0.8µm
Kontaktzone selektiv vorversilbert min. 3µm
- △ PUNCHED WITH VOLATILIZING STAMPING-OIL
Gestanzl mit vertuechtigendem Stanzoel
- △ SERRATIONS OVER THE WHOLE WIDTH OF THE CRIMP AREA
Rillen ueber die ganze Breite des Crimpbereichs.

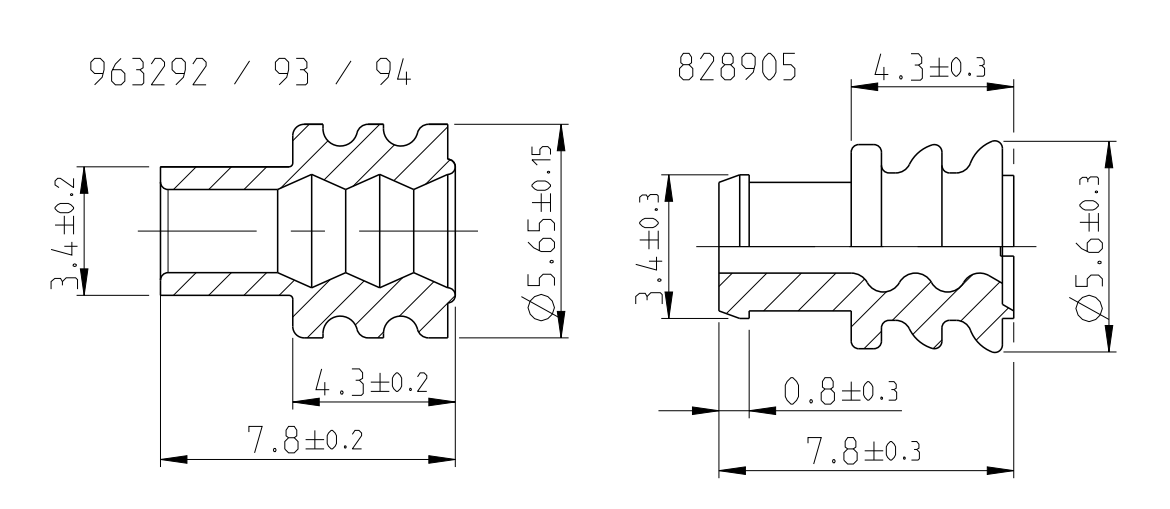

SINGLE WIRE SEAL Einzel-Dichtung		
963292-1	2.7-3.0	yellow gelb
963293-1	2.0-2.7	redbrown rotbraun
963294-1	1.2-2.1	blue blau
828905-1	2.2-3.0	white weiss
ORDER No. Bestell-Nr.	INSULATION Ø Isolations Ø	COLOR Farbe

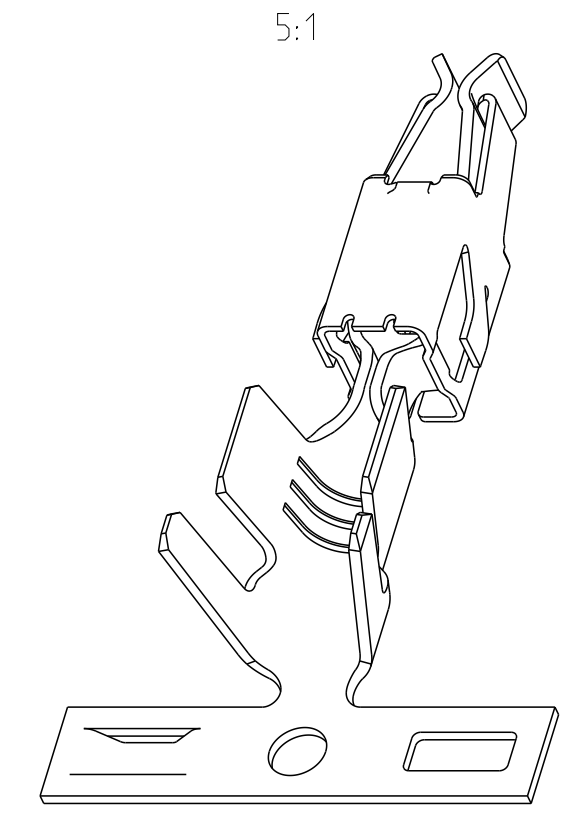

THIS DRAWING IS A CONTROLLED DOCUMENT. DATE: 18.AUG.2000. DRAWN BY: Pfeilschiffer. CHECKED BY: Huhn. APPROVED BY: Pfeilschiffer. DATE: 02.JUN.2003. PRODUCT SPEC: 108-18013. APPLICATION SPEC: 114-18050. WEIGHT: -. CUSTOMER: Drawing. SCALE: 5:1. SHEET: 1 OF 1. RESTRICTION: A0. ©=1355047.

STE TE Connectivity
 PRODUCT GROUP DRAWING FOR JUNIORPOWER TIMER CONTACT TYPE A
 Produkt-Gruppenzeichnung fuer JPT Typ A

X-ON Electronics

Largest Supplier of Electrical and Electronic Components

Click to view similar products for [Automotive Connectors](#) category:

Click to view products by [TE Connectivity](#) manufacturer:

Other Similar products are found below :

[003-018-000](#) [600858](#) [60403001](#) [60993906-B](#) [60993913-B](#) [629515004020001](#) [M83723/71R1808N L/C](#) [M902-2131](#) [M902-2161](#) [M902-2344](#)
[72.330.1035.1](#) [73.353.4028.0](#) [F118010](#) [F119300-B](#) [F132210](#) [F166900](#) [F180100](#) [F258300](#) [F258300-B](#) [F294300-B](#) [F339100](#) [F339700](#)
[F358300-B](#) [F374110](#) [F407400](#) [F412210](#) [F444110](#) [F487000](#) [F495100](#) [F500900-B](#) [F509500B-B](#) [770444-1](#) [827153-1](#) [881735-1](#)
[8N1515-32-24P](#) [9-1326729-8](#) [925467-1](#) [925474-1](#) [928905-1](#) [936398-2](#) [964562-4](#) [964731-2](#) [968782-1](#) [GT17SA-8DS-HU](#) [GT17VS-10DP-](#)
[5.2CF](#) [98315-0001](#) [98315-0010](#) [98891-1012](#) [98895-2014](#) [98936-1039](#)