

## GELCAP MOTOR CONNECTION KIT - 1000V

GREAT SEAL, EXCELLENT INSULATION, COMPACT DESIGN

### KEY FEATURES

- PowerGel sealing gel filling, operates in SF6 and insulating liquids
- Fast and simple to install
- Easy re-entry

Our GelCap motor connection kits quickly and conveniently insulate, seal, and protect stub splice connections up to 1000 volts. The robust yet compact design was engineered to handle the harsh environment of motor connections. GelCap kits are equally well suited to many other connection applications including street light connections.

To install the GelCap motor connection kit, simply push the cover down over the connection and snap the clamp closed. The PowerGel sealing gel is already in the cap, no extra material or grease is required.

The corner of the stub connection is easy to reenter as the PowerGel sealing gel pulls away leaving a clean connection. Re-entry is also safer than other methods because no sharp objects or cutting tools are required for removal of the cap.

The GelCap motor connection kits feature revolutionary PowerGel sealing gel which provides an excellent moisture seal over a wide temperature range (-40°C to 105°C). PowerGel sealing gel has excellent insulating properties and the added benefit of acting as a vibration damper.

**Customers can count on consistent, high quality products, driven by TE's proven innovation and backed by our extraordinary customer support.**

## Gelcap Motor Connection Kit - 1000V



The GelCap motor connection kits feature revolutionary PowerGel sealing gel which provides an excellent moisture seal over a wide temperature range (-40°C to 105°C). PowerGel sealing gel has excellent insulating properties and the added benefit of acting as a vibration damper.

Molded clamp of UV stable, impact resistant polypropylene secures cover in place.

Molded cover of high abrasive and impact resistant elastomer provides rugged protection for electrical connection.

Silicone gel is high dielectric insulation and provides constant pressure on cable and connector to provide waterseal. PowerGel sealing gel is specially formulated for high temperature environments.

Snap-lock feature provides quick installation and removal.

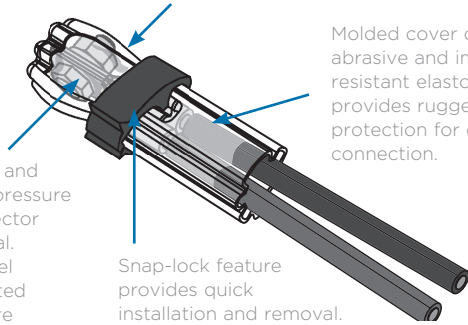

TESTING	
Testing	Test Conditions
Chemical Resistance	ASTM D543, Sulfuric acid, Sodium hydroxide, transformer and motor oil
Ozone Resistance	ASTM D1149, 120 hours @ 40°C, 50pphm
Accelerated Aging	ASTM D2671
UV Resistance	ASTM G53, UVB, 4000 hours, 4 hour on/off cycle
Abrasion Resistance	2040 gm wt., 4000 cycles, 5% max thickness loss

PRODUCT SELECTION INFORMATION	
Description	Feeder Conductor Size (mm <sup>2</sup> )
GelCap 1*	#16 - #10 AWG (1.5 - 5)
GelCap 2	#8 - #2 AWG (8 - 35)
GelCap 3	#2 - #4/0 AWG (35 - 105)
GelCap 4	250 - 500 kcmil (125 - 250)

\*For wire sizes #16 - #10 the unique design of the "GelCap 1" kit saves space by allowing all three phase connections to be installed in one cover. Product sizes 2, 3, and 4 include one cap per phase.

TEST REPORT
Related Product Information: EDR-5334 Test Report



[te.com/energy](http://te.com/energy)

©2019 TE Connectivity. All Rights Reserved. E145-0719-EN

Raychem, TE, TE Connectivity and the TE connectivity (logo) are trademarks of the TE Connectivity Ltd. Family of companies. Other logos, product and Company names mentioned herein may be trademarks of their respective owners. While TE has made every reasonable effort to ensure the accuracy of the information in this brochure, TE does not guarantee that it is error-free, nor does TE make any other representation, warranty or guarantee that the information is accurate, correct, reliable or current. TE reserves the right to make any adjustments to the information contained herein at any time without notice. TE expressly disclaims all implied warranties regarding the information contained herein, including, but not limited to, any implied warranties of merchantability or fitness for a particular purpose. The dimensions in this brochure are for reference purposes only and are subject to change without notice. Specifications are subject to change without notice. Consult TE for the latest dimensions and design specifications

### FOR MORE INFORMATION: TE Technical Support Centers

USA:	+ 1 800 327 6996
France:	+ 33 380 583 200
UK:	+ 44 0870 870 7500
Germany:	+ 49 896 089 903
Spain:	+ 34 916 630 400
Italy:	+ 39 333 250 0915
Benelux:	+ 32 16 508 695
Canada:	+ 1 (905) 475-6222
Mexico:	+ 52 (0) 55-1106-0800
Latin/S. America:	+ 54 (0) 11-4733-2200
China:	+ 86 (0) 400-820-6015

## X-ON Electronics

Largest Supplier of Electrical and Electronic Components

*Click to view similar products for [Wire Ducting](#) category:*

*Click to view products by [TE Connectivity](#) manufacturer:*

Other Similar products are found below :

[66200A-10](#) [CVED32VEPG](#) [CVED40VEPG](#) [F512D5-5F140Y](#) [F512D5-5F200Y](#) [F512D5-5F26Y](#) [F512D5-5F30Y](#) [F512D5-5F33Y](#) [F512D5-5F34Y](#) [F512D5-5F45Y](#) [F512D5-5F50Y](#) [F512D5-5F54Y](#) [F512D5-5F66Y](#) [F512D5-5F70Y](#) [F512D5-5F75Y](#) [F512D5-5F90Y](#) [F612D5-5F100Y](#) [F612D5-5F130Y](#) [F612D5-5F50Y](#) [F612D5-5F56Y](#) [F612D5-5F58Y](#) [F6L12D5-5F46](#) [F912D5-5F11Y](#) [F912D5-5F170Y](#) [F912D5-5F175Y](#) [F912D5-5F230Y](#) [F912D5-5F300Y](#) [F912D5-5F55Y](#) [F912D5-5F56Y](#) [F912D5-5F63Y](#) [F912D5-5F6Y](#) [F912D5-5F75Y](#) [F912D5-5F85Y](#) [F912D5-5F86Y](#) [F912D5-5F88Y](#) [F912D5-5F96Y](#) [FAP0047WBLMTP](#) [FAP12WBRDRDDLZ](#) [FAP12WDYLYLDLZ](#) [FAP12WEORORDLZ](#) [FAP6WEORORDLZ](#) [FAP6WFDBDBDLZ](#) [FAP8WEORORDLZ](#) [FCE2UWCL](#) [800A-LB](#) [802A-ECSP](#) [802I-ICSP](#) [FJQADH](#) [FJQFXT](#) [PED10](#)