



## ANT-MAG-SMAF-cccc-1 Magnetic Remote Antenna Base

The ANT-MAG-SMAF-cccc-1 is a magnetic externally mounted connector base incorporating an SMA jack (female socket) on a 1 meter length of LMR195 low-loss coaxial cable terminating in an SMA plug (male pin), RP-SMA jack (female socket), N plug (male pin) or TNC plug (male pin) connector.

The ANT-MAG-SMAF-cccc-1 combines a strong magnetic mount with typical connectors to create new mounting options for most any whip/blade-style connectorized antenna.

### FEATURES

- SMA jack (female socket)
  - Integrated magnetic base securely attaches to ferrous metallic surfaces and allows for repositioning
  - Gold plated body and center contact
  - Silicone gasket provided to aid seal to antenna
- Connector options (cabled end)
  - SMA plug (male pin)
  - Reverse-polarity SMA plug (female socket)
  - N plug (male pin)
  - TNC plug (male pin)
- LMR195 low-loss coaxial cable
  - Compliant to VW-1
- ABS housing and PVC Base materials
  - Compliant to UL 940V-0
- IP67 rated (connectors, base and coax)

### APPLICATIONS

- Cellular IoT - LTE-M (Cat-M1), NB-IoT
- Cellular - 5G/4G LTE/3G/2G
- LPWA
  - LoRaWAN®, Sigfox®, WiFi HaLow™ (802.11ah)
- ISM - Bluetooth®, ZigBee®
- GNSS - GPS, Galileo, BeiDou, QZSS
- Remote control, monitoring and sensing
- Internet of Things (IoT) devices
- Automotive, Industrial, Commercial, Enterprise

### ORDERING INFORMATION

Part Number	Description
ANT-MAG-SMAF-SMAM-1	Magnetic remote antenna mount SMA jack (female socket) to SMA plug (male pin) on 1 meter of LMR195 low-loss coaxial cable
ANT-MAG-SMAF-RPSM-1	Magnetic remote antenna mount SMA jack (female socket) to RP-SMA plug (female socket) on 1 meter of LMR195 low-loss coaxial cable
ANT-MAG-SMAF-NM-1	Magnetic remote antenna mount SMA jack (female socket) to N plug (male pin) on 1 meter of LMR195 low-loss coaxial cable
ANT-MAG-SMAF-TNCM-1	Magnetic remote antenna mount SMA jack (female socket) to TNC plug (male pin) on 1 meter of LMR195 low-loss coaxial cable

Available from Linx Technologies and select distributors and representatives.

## TABLE 1. ELECTRICAL SPECIFICATIONS

Parameter	Value			
	ANT-MAG-SMAF-SMAM	ANT-MAG-SMAF-RPSM	ANT-MAG-SMAF-NM	ANT-MAG-SMAF-TNCM
Insertion Loss (dB max)	2.1	1.7	1.5	1.6
VSWR (max)	2.2	1.7	1.5	1.3
Impedance	50 Ω			
Insulation Resistance	500 MΩ min.			
Max. Power Rating	10 W			
Operating Temp. Range	-40 °C to +105 °C			

## PRODUCT DIMENSIONS

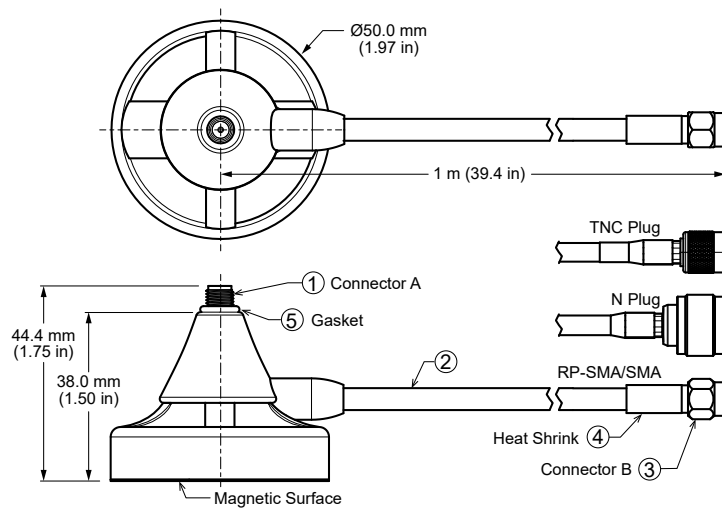

Figure 1: Product Dimensions for the ANT-MAG-SMAF-cccc-1 Cable Assembly

## TABLE 2. CABLE ASSEMBLY COMPONENTS

Item #	Description	Material	Finish
1	Connector, SMA jack (female socket) right-angle magnetic base	Brass	Gold
2	LMR195 coaxial cable	LMR195	-
3	See Table for cable-end connector options	-	-
4	Heat Shrink Tubing	PTFE	-
5	Gasket	Silicone	-

## TABLE 3. CABLE ASSEMBLY MECHANICAL SPECIFICATIONS

Parameter	Connector A SMA jack (female socket)	Connector B (See Table 4)
Fastening Type	1/4"-36 UNS-2A threaded coupling	A
Recommended Torque	0.9 N m (8.0 in lbs)	B
Coupling Nut Retention	60 lbs. min.	C
Connector Durability	500 cycles min.	D
Weight		E

**TABLE 4. CABLE-END CONNECTOR (CONNECTOR B) PARAMETERS**

	SMA plug (male pin)	RP-SMA plug (female socket)	N plug (male pin)	TNC plug (male pin)
	ANT-MAG-SMAF-SMAM-1	ANT-MAG-SMAF-RPSM-1	ANT-MAG-SMAF-NP-1	ANT-MAG-SMAF-TNC-1
A	1/4"-36 UNS-2B	1/4"-36 UNS-2B	5/8"-24UNEF	7/16"-28UNEF
B	0.9 N m (8.0 in lbs)	0.9 N m (8.0 in lbs)	0.9 N m (8.0 in lbs)	1.14 N·m (10.0 in·lbs)
C	60 lbs. min.	60 lbs. min.	60 lbs. min.	100 lbs min.
D	500 cycles min.	500 cycles min.	500 cycles min.	500 cycles min.
E	127.5 g (4.50 oz)	127.3 g (4.50 oz)	148.2 g (5.23 oz)	126.8 g (4.47 oz)

**COAXIAL CABLE SPECIFICATIONS**

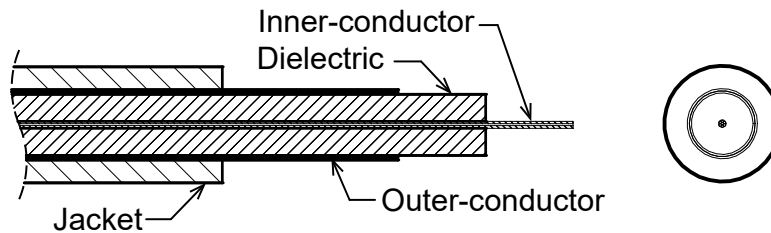

Figure 2: Coaxial Cable Cutaway Diagram

**TABLE 5. COAXIAL CABLE MATERIAL SPECIFICATIONS FOR LMR195**

LMR195 Coax	Material	Dimensions
Inner-Conductor	Copper, single strand	Ø0.95 mm (0.040 in)
Dielectric	Foam-PE	Ø2.95 mm (0.120 in)
Outer-Conductor	Aluminum mylar over copper braid, Coverage 85%	Ø3.19 mm (0.130 in)
Jacket	PVC, Black	Ø5.00 mm (0.200 in)

**TABLE 6. COAXIAL CABLE ELECTRICAL AND PHYSICAL SPECIFICATIONS FOR LMR195**

Parameter	Value		
Rated Temp Voltage	105 °C 30 V		
Conductor Resistance	25.3 Ω/km max @20 °C		
Insulation Resistance	100 M Ω·km min.		
Dielectric Strength	AC 500 V/Minute		
Spark Test	1.5 kV		
Insulation	Unaged	Tensile Strength	1500 psi min. (1.76 kg/mm <sup>2</sup> )
		Elongation	200% min.
	Aged	Tensile Strength	Unaged min. 70% (168 hrs x 232 °C)
		Elongation	Unaged min. 65% (168 hrs x 232 °C)
Jacket	Unaged	Tensile Strength	2500 psi min. (1.76 kg/mm <sup>2</sup> )
		Elongation	200% min.
	Aged	Tensile Strength	Unaged min. 70% (168 hrs x 232 °C)
		Elongation	Unaged min. 65% (168 hrs x 232 °C)
Nominal Impedance	50 ± 3 Ω		
Minimum Inside Bend radius	12.7 mm (0.5 in)		

## INSERTION LOSS

Figure 3 shows the Insertion Loss for ANT-MAG-SMAF-cccc-1 cable assembly. Insertion loss is the loss of signal power (gain) resulting from the insertion of a device in a transmission line.

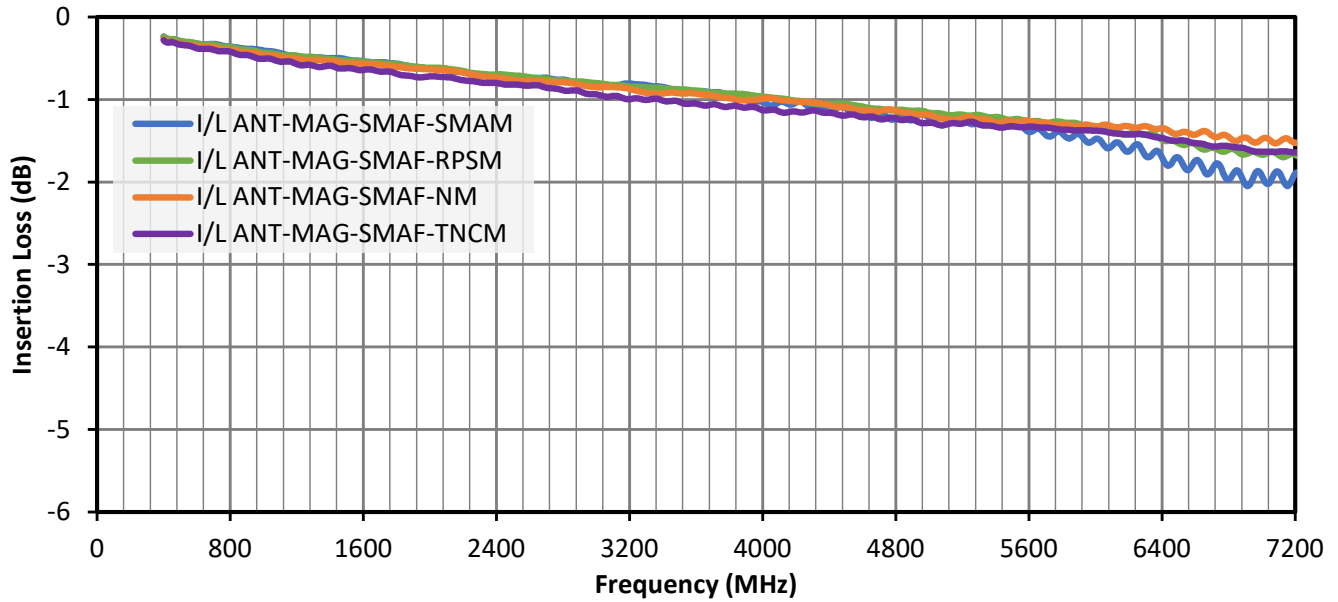

Figure 3: Insertion Loss for the ANT-MAG-SMAF-cccc-1 Cable Assembly

## VSWR

Figure 4 provides the voltage standing wave ratio (VSWR) across the cable assembly's bandwidth for the ANT-MAG-SMAF-cccc-1 cable assembly. VSWR describes how efficiently power is transmitted through the cable assembly. A lower VSWR value indicates better performance at a given frequency.

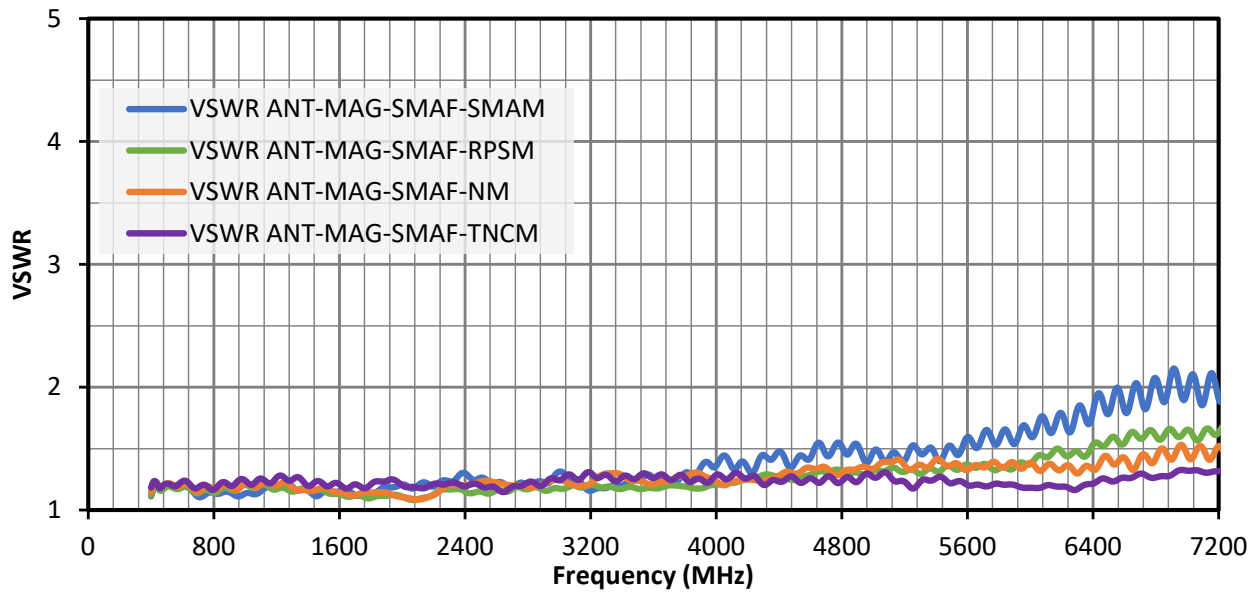

Figure 4: VSWR for the ANT-MAG-SMAF-cccc-1 Cable Assembly

---

## PACKAGING INFORMATION

The ANT-MAG-SMAF-cccc-1 magnetic antenna base assembly is packaged in a clear plastic bag, which is sealed in labeled plastic bags of 10 pcs. Antennas are packaged in boxes in quantities of 100 pcs. Distribution channels may offer alternative packaging options.

## CONNECTOR & ADAPTER DEFINITIONS AND USEFUL FORMULAS

**VSWR** - Voltage Standing Wave Ratio. VSWR is a unitless ratio that describes how efficiently power is transmitted through the connector. A lower VSWR value indicates better performance at a given frequency. VSWR is easily derived from Return Loss.

$$VSWR = \frac{10^{\left[\frac{\text{Return Loss}}{20}\right]} + 1}{10^{\left[\frac{\text{Return Loss}}{20}\right]} - 1}$$

**Insertion Loss** - The loss of signal power (gain) resulting from the insertion of a device in a transmission line. Insertion loss can be derived from the power transmitted to the load before the insertion of the component  $P_T$  and the power transmitted to the load after the insertion of the component  $P_R$ .

$$\text{Insertion Loss (dB)} = 10 \log_{10} \frac{P_T}{P_R}$$

## TE TECHNICAL SUPPORT CENTER

USA:	+1 (800) 522-6752
Canada:	+1 (905) 475-6222
Mexico:	+52 (0) 55-1106-0800
Latin/S. America:	+54 (0) 11-4733-2200
Germany:	+49 (0) 6251-133-1999
UK:	+44 (0) 800-267666
France:	+33 (0) 1-3420-8686
Netherlands:	+31 (0) 73-6246-999
China:	+86 (0) 400-820-6015

## te.com

TE Connectivity, TE, TE connectivity (logo), Linx and Linx Technologies are trademarks owned or licensed by the TE Connectivity Ltd. family of companies. All other logos, products and/or company names referred to herein might be trademarks of their respective owners.

The information given herein, including drawings, illustrations and schematics which are intended for illustration purposes only, is believed to be reliable. However, TE Connectivity makes no warranties as to its accuracy or completeness and disclaims any liability in connection with its use. TE Connectivity's obligations shall only be as set forth in TE Connectivity's Standard Terms and Conditions of Sale for this product and in no case will TE Connectivity be liable for any incidental, indirect or consequential damages arising out of the sale, resale, use or misuse of the product. Users of TE Connectivity products should make their own evaluation to determine the suitability of each such product for the specific application.

TE Connectivity warrants to the original end user customer of its products that its products are free from defects in material and workmanship. Subject to conditions and limitations TE Connectivity will, at its option, either repair or replace any part of its products that prove defective because of improper workmanship or materials. This limited warranty is in force for the useful lifetime of the original end product into which the TE Connectivity product is installed. Useful lifetime of the original end product may vary but is not warranted to exceed one (1) year from the original date of the end product purchase.

©2023 TE Connectivity. All Rights Reserved.

1/23 Original

## X-ON Electronics

Largest Supplier of Electrical and Electronic Components

*Click to view similar products for [Antenna Accessories](#) category:*

*Click to view products by [TE Connectivity](#) manufacturer:*

Other Similar products are found below :

[HKIT-MTA9101-001](#) [YMST4](#) [NMOHPCN518](#) [MB830](#) [MB825](#) [MB820](#) [GRO](#) [W9909](#) [HKIT-MTA9100-001](#) [HKIT-LPx-001](#) [GPS-17519](#)  
[MABT8M](#) [KH-IPEX3-0.81](#) [HJ-IPEX1-1.13-SMA-L=100mm](#) [3C0224M01-003](#) [KHA\(RG1.37\)-TX300B-IPEX](#) [KHA\(RG1.37\)-TX80B-IPEX](#)  
[KHA\(RG1.37\)-TX140B-IPEX](#) [KH-IPEXA-SMAKWE-B060H](#) [KHA\(RG1.37\)-TX90B-IPEX](#) [KH-IPEX-SMA-RG137-120MM](#) [KH-SMAKW-](#)  
[IPEX4-RG1.13-B300](#) [KH-SMAKW-IPEX4-RG0.81-B90](#) [KH-SMAKW-IPEX4-RG1.37-B80](#) [KH-SMAKW-IPEX4-RG1.37-B160](#) [KH-](#)  
[SMAKW-IPEX-RG0.81-B70](#) [KH-SMAKW-IPEX-RG0.81-B140](#) [KHA-\(RG1.13\)-TX120-IPEX-221](#) [KHA\(RG1.37\)-TX70B-IPEX](#) [KH-](#)  
[SMAKW-IPEX-RG1.78-250](#) [KH-SMAKW-IPEX4-RG0.81-B200](#) [KH-SMAKW-IPEX4-RG1.13-B70](#) [KH-SMAKW-IPEX4-RG1.37-B90](#) [KH-](#)  
[SMAJ-221-RG1.78-160](#) [KH-SMAJ-IPEX-RG1.37-B70](#) [KH-SMAJ-IPEX-RG1.37-B60](#) [KH-FL2SMAK-IPEX3-RG0.81-B160](#) [KH-FL2SMAK-](#)  
[IPEX4-RG0.81-B100](#) [KH-FL2SMAK-IPEX-RG1.13-B70](#) [KH-FL2SMAK-IPEX4-RG1.13-B90](#) [KH-FL2SMAK-IPEX-RG1.37-B60](#) [KH-](#)  
[FL2SMAK-IPEX-RG1.37-B120](#) [KH-FL2SMAK-IPEX4-RG1.37-B80](#) [KH-FL2SMAK-IPEX4-RG1.37-B160](#) [KH-FL2SMAK-IPEX-RG178-](#)  
[100](#) [KH-FL2SMAK-IPEX-RG178-200](#) [KH-SMAJ-221-RG1.13-B70](#) [KH-SMAJ-221-RG1.37-B90](#) [KH-FL2SMAK-IPEX-RG0.81-B50](#) [KH-](#)  
[FL2SMAK-IPEX3-RG0.81-B300](#)