

SPECIFICATION CONTROL DRAWING

7724E2664

CHEMINAX

77 OHM, AWG 24, 19 STRANDS OF AWG 36,
DATA BUS CABLE, OUTER SPACE USE

Date: 8-8-18
Revision: E

THIS SPECIFICATION SHEET FORMS A PART OF THE LATEST ISSUE OF RAYCHEM SPECIFICATION 1200.

CONSTRUCTION DETAILS

ELECTRICAL CHARACTERISTICS

DIMENSIONS ARE NOMINAL VALUES IN INCHES, UNLESS OTHERWISE DESIGNATED.

CHARACTERISTIC IMPEDANCE	77 ± 7 ohms, Method C at 1 MHz
MUTUAL CAPACITANCE	30.0 pF/ft. (maximum)
ATTENUATION	1.0 dB/100 ft. (nominal) at 1 MHz 8.0 dB/100 ft. (maximum) at 10 MHz
SURFACE TRANSFER IMPEDANCE	70 milliohms/meter (nominal) at 10 MHz

ADDITIONAL REQUIREMENTS

**COMPONENT WIRE PRIOR TO CABLING
(Test procedures per SAE AS22759)**

CONDUCTOR RESISTANCE	26.5 ohms/1000 ft. (nominal)
CROSSLINKING PROOF TEST	300 ± 3°C for 1 hour, .500 inch mandrel, .500 lb, 2.5 kV dielectric test
INSULATION (DIELECTRIC) ELONGATION	50% (minimum)
TENSILE STRENGTH	5000 lbf/in ² (minimum)
INSULATION FLAWS SPARK TEST	3.0 kV (rms)
IMPULSE TEST	8.0 kV (peak)
INSULATION RESISTANCE	5000 megohms for 1000 ft. (minimum)
LOW TEMPERATURE-COLD BEND	-65 ± 3°C for 4 hours, .500 inch mandrel, 1.00 lb, 2.5 kV dielectric test
SHRINKAGE	200 ± 3°C for 1 hour, .125 inch (maximum) in 12 inches

FINISHED CABLE

(Test procedures per NEMA WC 27500, unless otherwise specified)

BLOCKING	200°C for 6 hours
CABLE LAY LENGTH	.75 inch (minimum), 1.25 inches (maximum)
CROSSLINKED VERIFICATION	300 ± 5°C for 6 hours, 6.00 inch mandrel
FLAMMABILITY (Method B of Spec 1200)	3 seconds (maximum), 3 inches (maximum); no flaming of facial tissue
JACKET ELONGATION	50% (minimum)
TENSILE STRENGTH	5000 lbf/in ² (minimum)
JACKET FLAWS SPARK TEST	1.0 kV (rms)
IMPULSE TEST	6.0 kV (peak)
JACKET THICKNESS	.008 inch (nominal)
LOW TEMPERATURE-COLD BEND	-55 ± 5°C for 4 hours, 6.00 inch mandrel
SHIELD COVERAGE	90% (minimum)
VOLTAGE WITHSTAND (DIELECTRIC)	1000 volts (rms) (minimum)
WEIGHT	10.4 lbs/1000 ft. (nominal)

OUTER SPACE REQUIREMENTS

RADIATION RESISTANCE	500 megarads/3.75 inch mandrel
VACUUM STABILITY TOTAL MASS LOSS (TML)	1.00% (maximum)
VOLATILE CONDENSABLE MATERIAL (VCM)	0.10% (maximum)
WEIGHT LOSS	0.45% (maximum)

ENGINEERING REFERENCE

TEMPERATURE RATING	200°C (maximum)
--------------------	-----------------

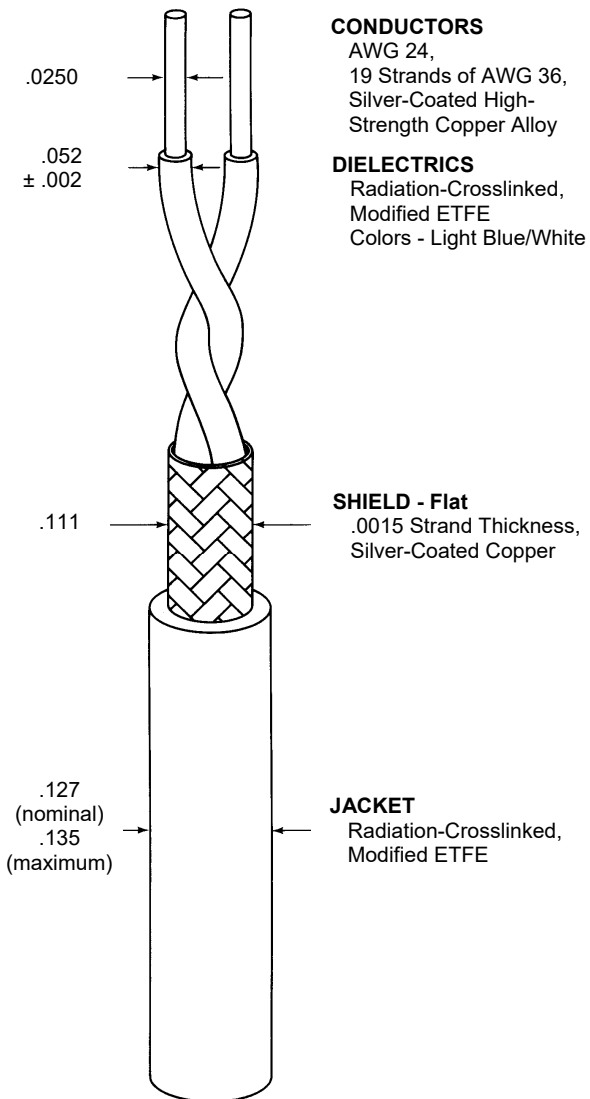

Designate outer jacket color with a dash number in accordance with MIL-STD-681. Unless otherwise specified, outer jacket color will be white designated by a "-9" appended to the part number, e.g. 7724E2664-9.

Other codes and suffixes may be added to the part number, as necessary, to capture any additional requirements imposed by the purchase order.

Users should evaluate the suitability of this product for their application. Specifications are subject to change without notice. TE Connectivity also reserves the right to make changes in materials or processing, which do not affect compliance with any specification, without notification to Buyer.



X-ON Electronics

Largest Supplier of Electrical and Electronic Components

Click to view similar products for [Coaxial Cables](#) category:

Click to view products by [TE Connectivity](#) manufacturer:

Other Similar products are found below :

[89880-003-1000](#) [CY2389-000](#) [8221-010-U1000](#) [9116-010-U500](#) [1322R-010-1000](#) [1807A-B59-U1000](#) [2020K8421-9X-CS3417](#) [9251-010-1000](#) [9275-010-U1000](#) [935240-000](#) [980704-001](#) [CF2823-000](#) [33312-010-500](#) [CZ1589-000](#) [5022W0809-0CS3263](#) [10610-4-4](#) [EF8108-000](#) [1673B TIN100](#) [672525-001](#) [144517-000](#) [735A1-008-1000](#) [8212-010-U500](#) [480414-000](#) [7915A 009U1000](#) [5024A1311-0](#) [1281S5 010250](#) [1530A 010U1000](#) [9248 010U1000](#) [9244 0101000](#) [1694A 0081000](#) [1190A 0101000](#) [8241F J5C1000](#) [1674A TIN50](#) [7915A 0091000](#) [TRCH-50-2](#) [9066 0031000](#) [7805R 008100](#) [1674A TIN100](#) [9116SB 0101000](#) [9271 0061000](#) [1613A 0101000](#) [1807A B591000](#) [5339Q5 009U500](#) [539945 0091000](#) [9116R 0101000](#) [89207 010100](#) [9058 0101000](#) [8241A 0101000](#) [DA7805R 0101000](#) [C6424](#)