

Type CPF-A Series

Key Features

AEC-Q200

Compliance

Advanced thin film technology

RoHS compliant

Special materials, design, and processing for high sulfur applications

Test proven immunity to humidity, moisture, and sulfur



TE Connectivity are pleased to introduce the sister of our CPF thin film chip resistor, the AEC-Q200 compliant CPF-A series. Supplied on tape and reel for ease of insertion, and available in 7 sizes / power ratings up to 0.5W

Characteristics – Electrical

Applications

Automotive

Medical

Testing / Measurement

Communication

Size	Power Rating @70°C	Operating Temp. Range	Max. Operating Voltage	Max. Overload Voltage	Resistance Range				TCR PPM/°C
					±0.05%	±0.1%	±0.5%	±1%	
0402	0.0625W	-55 ~ +155°C	25V	50V	49.9Ω - 10KΩ	49.9Ω - 100KΩ			±25 ±50
0603	0.0625W	-55 ~ +155°C	50V	100V	10Ω - 49.9KΩ	10Ω - 332KΩ			±25 ±50
0805	0.1W	-55 ~ +155°C	100V	200V	10Ω - 100KΩ	10Ω - 1MΩ			±25 ±50
1206	0.125W	-55 ~ +155°C	150V	300V	10Ω - 200KΩ	10Ω - 1MΩ			±25 ±50
1210	0.25W	-55 ~ +155°C	150V	300V	10Ω - 499KΩ	10Ω - 1MΩ			±25 ±50
2010	0.25W	-55 ~ +155°C	150V	300V	10Ω - 499KΩ	10Ω - 1MΩ			±25 ±50
2512	0.5W	-55 ~ +155°C	150V	300V	10Ω - 499KΩ	10Ω - 1MΩ			±25 ±50

Operating Voltage= $\sqrt{P \cdot R}$ or Max. operating voltage listed above, whichever is lower.

Overload Voltage= $2.5 \cdot \sqrt{P \cdot R}$ or Max. overload voltage listed above, whichever is lower

Derating Curve

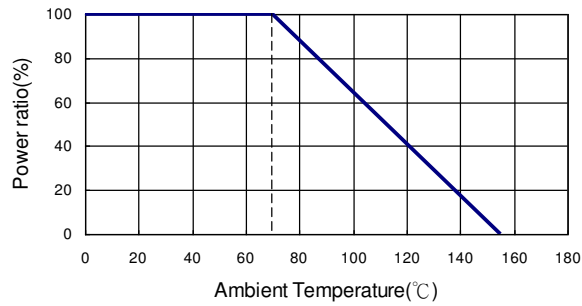

Construction and dimensions

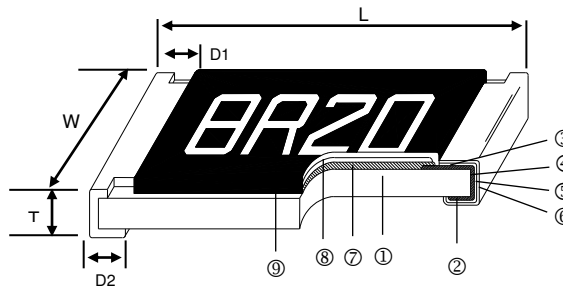

① Alumina Substrate	④ Edge Electrode (NiCr)	⑦ Resistor Layer (NiCr)
② Bottom Electrode (Ag)	⑤ Barrier Layer (Ni)	⑧ Overcoat (Epoxy)
③ Top Electrode (Ag-Pd or Cu)	⑥ External Electrode (Sn)	⑨ Marking

Size	L	W	T	D1	D2	Weight (g) (1000pcs)
0402	1.00±0.05	0.50±0.05	0.30±0.05	0.20±0.10	0.20±0.10	0.54
0603	1.55±0.10	0.80±0.10	0.45±0.10	0.30±0.20	0.30±0.20	1.83
0805	2.00±0.15	1.25±0.15	0.55±0.10	0.30±0.20	0.40±0.20	4.71
1206	3.05±0.15	1.55±0.15	0.55±0.10	0.42±0.20	0.35±0.25	9.02
1210	3.10±0.15	2.40±0.15	0.55±0.10	0.40±0.20	0.55±0.25	10
2010	4.90±0.15	2.40±0.15	0.55±0.10	0.60±0.30	0.50±0.25	23.61
2512	6.30±0.15	3.10±0.15	0.55±0.10	0.60±0.30	0.50±0.25	38.06

Environmental Characteristics

Item	Requirement	Test Method
Temperature Coefficient of Resistance (TCR)	As Spec	JIS-C-5201-1 4.8 IEC-60115-1 4.8 -55°C~155°C, 25°C is the reference temperature
Short Term Overload	$\Delta R \pm 0.05\%$	JIS-C-5201-1 4.13 RCWV*2.5 or maximum overload voltage, whichever is lower for 5 seconds
Insulation Resistance	>1000M Ω	JIS-C-5201-1 4.6 IEC-60115-1 4.6 Apply 100vdc for 1 minute
Operational Life	$\Delta R \pm 0.2\%$	MIL-STD-202 method 108 Condition D steady state TA=125°C at rated power. Measurement taken 24±4 hours after test conclusion
Biased Humidity	$\Delta R \pm 0.1\%$	MIL-STD-202 method 103 1000 hours 85°C 85%RH 10% of operating power
High Temperature Exposure	$\Delta R \pm 0.2\%$	MIL-STD-202 method 108 At 155°C for 1000 Hours
Temperature Cycling	$\Delta R \pm 0.1\%$	JESD-22 method JA- 104
Bending Strength (Board Flex)	$\Delta R \pm 0.1\%$	JIS-C-5201-1 4.33 Bending once for 60 seconds Bending displacement 2010 / 2512 = 2mm Other sizes = 3mm
Solderability	95% min. coverage	JIS-C-5201-1 4.17 IEC-60115-1 4.17 245 ±5°C for 3 seconds
Resistance to Soldering Heat	$\Delta R \pm 0.05\%$	JIS-C-5201-1 4.18 IEC-60115-1 4.18 260 ±5°C for 10 seconds
Terminal Strength	Not Broken	AEC-Q200-006 Force of 1.8kg for 60 seconds.
Mechanical Shock	$\Delta R \pm 0.1\%$	MIL-STD-202 method 213 Wave Form: Tolerance for half sine shock pulse. Peak value 100g's. Normal duration (D) is 6
Vibration	$\Delta R \pm 0.1\%$	MIL-STD-202 method 204 5 g's for 20 minutes. 12 cycles each of 3 orientations. 10 ~ 2000 Hz
ESD	$\Delta R \pm 0.1\%$	AEC-Q200-002 Human body 2KV
Resistance to Solvents	Marking undamaged	MIL-STD-202 method 215 Add aqueous wash chemical – OKEM Clean or equivalent. Do not use banned solvents.
Sulfur Test	$\Delta R \pm 1\%$	EIA-997 (condition B) 105 ±2°C no power rating for 750 hours
Flammability	No ignition of tissue paper or scorching of pinewood board	UL94 V-0 or V-1 are acceptable. No electrical testing required

RCWV (rated continuous working voltage)= $\sqrt{P \cdot R}$ or Max. operating voltage listed above, whichever is lower

Marking:

0603 3digit marking for E96



3digit marking for Example: 14C=13K7Ω 13C=13K3Ω

Marking Table

Code	E96	Code	E96	Code	E96	Code	E96				
01	100	25	178	49	316	73	562				
02	102	26	182	50	324	74	576				
03	105	27	187	51	332	75	590				
04	107	28	191	52	340	76	604				
05	110	29	196	53	348	77	619				
06	113	30	200	54	357	78	634				
07	115	31	205	55	365	79	649				
08	118	32	210	56	374	80	665				
09	121	33	215	57	383	81	681				
10	124	34	221	58	392	82	698				
11	127	35	226	59	402	83	715				
12	130	36	232	60	412	84	732				
13	133	37	237	61	422	85	750				
14	137	38	243	62	432	86	768				
15	140	39	249	63	442	87	787				
16	143	40	255	64	453	88	806				
17	147	41	261	65	464	89	825				
18	150	42	267	66	475	90	845				
19	154	43	274	67	487	91	866				
20	158	44	280	68	499	92	887				
21	162	45	287	69	511	93	909				
22	165	46	294	70	523	94	931				
23	169	47	301	71	536	95	953				
24	174	48	309	72	549	96	976				
Code	A	B	C	D	E	F	G	H	X	Y	Z
Multiplier	10 ⁰	10 ¹	10 ²	10 ³	10 ⁴	10 ⁵	10 ⁶	10 ⁷	10 ⁻¹	10 ⁻²	10 ⁻³

0603 3digit marking for E24 Example: 101=100Ω 102=1KΩ

E24	10	11	12	13	15	16	18	20	22	24	27	30
	33	36	39	43	47	51	56	62	68	75	92	91

0805~2512 4digit marking

Resistance	100Ω	2.2KΩ	10KΩ	49.9KΩ	100KΩ
marking	1000	2201	1002	4992	1003

Packaging Quantity and reel specifications

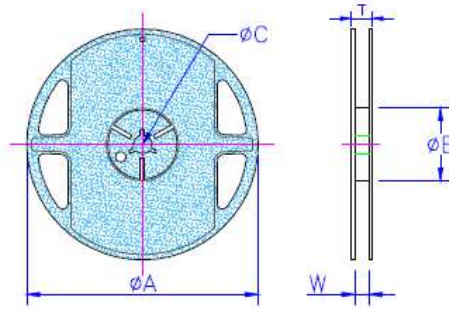

Type	ØA	ØB	ØC	W	T	Paper Tape (EA)	Emboss Plastic Tape (EA)
0402	178.0±1.0	60.0±1.0	13.5±0.7	9.5±1.0	11.5±1.0	1,000 / 5,000	-
0603	178.0±1.0	60.0±1.0	13.5±0.7	9.5±1.0	11.5±1.0	1,000 / 5,000	-
0805	178.0±1.0	60.0±1.0	13.5±0.7	9.5±1.0	11.5±1.0	1,000 / 5,000	-
1206	178.0±1.0	60.0±1.0	13.5±0.7	9.5±1.0	11.5±1.0	1,000 / 5,000	-
1210	178.0±1.0	60.0±1.0	13.5±0.7	9.5±1.0	11.5±1.0	1,000 / 5,000	-
2010	178.0±1.0	60.0±1.0	13.5±0.7	13.5±1.0	15.5±1.0	-	4,000
2512	178.0±1.0	60.0±1.0	13.5±0.7	13.5±1.0	15.5±1.0	-	4,000

Paper Tape Specifications

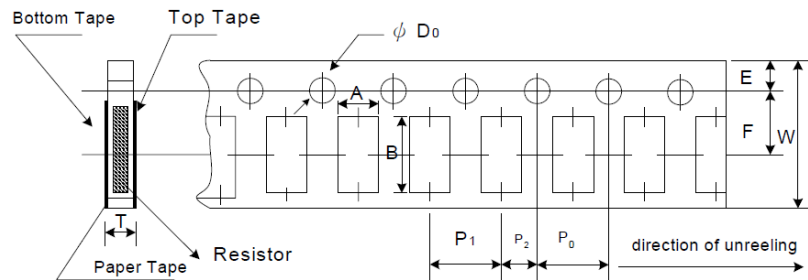

Type	A	B	W	E	F	P ₀	P ₁	P ₂	ØD ₀	T
0402	0.70±0.05	1.16±0.0	8.00±0.10	1.75±0.05	3.5±0.05	4.00±0.10	2.00±0.05	2.00±0.05	1.55±0.05	0.40±0.03
0603	1.10±0.05	1.90±0.0	8.00±0.10	1.75±0.05	3.5±0.05	4.00±0.10	4.00±0.10	2.00±0.05	1.55±0.05	0.60±0.03
0805	1.60±0.05	2.37±0.0	8.00±0.10	1.75±0.05	3.5±0.05	4.00±0.10	4.00±0.10	2.00±0.05	1.55±0.05	0.75±0.05
1206	2.00±0.05	3.55±0.0	8.00±0.10	1.75±0.05	3.5±0.05	4.00±0.10	4.00±0.10	2.00±0.05	1.55±0.05	0.75±0.05
1210	2.75±0.05	3.40±0.0	8.00±0.10	1.75±0.05	3.5±0.05	4.00±0.05	4.00±0.10	2.00±0.05	1.60±0.10	0.75±0.05

Peel force of top cover tape

The peel speed shall be about 300mm/min±5%

The peel force of top cover tape shall be between 8gf to 60gf

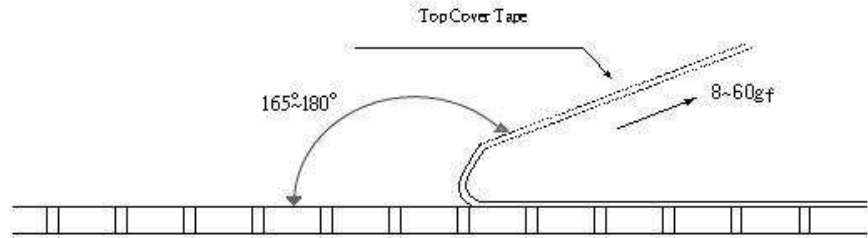

Embossed Plastic Tape Specifications

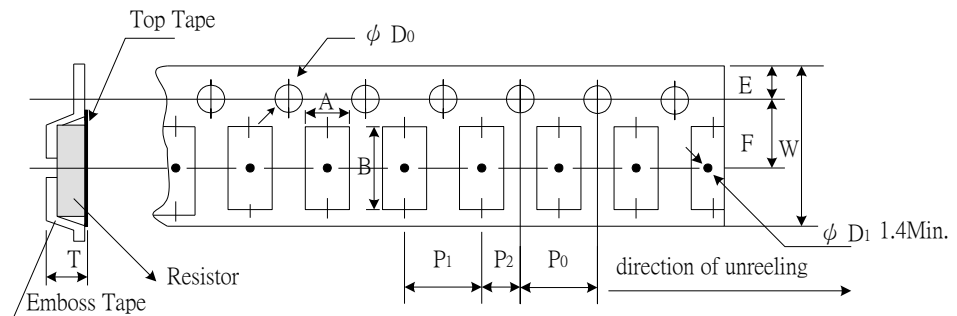

Type	A	B	W	E	F	P ₀	P ₁	P ₂	ØD ₀	T
2010	2.85±0.10	5.45±0.10	12.0±0.10	1.75±0.10	5.5±0.05	4.00±0.05	4.00±0.10	2.00±0.05	1.50±0.10	1.00±0.20
2512	3.40±0.10	6.65±0.10	12.0±0.10	1.75±0.10	5.5±0.05	4.00±0.05	4.00±0.10	2.00±0.05	1.50±0.10	1.00±0.20

Peel force of top cover tape

The peel speed shall be about 300mm/min±5%

The peel force of top cover tape shall be between 20gf to 80g

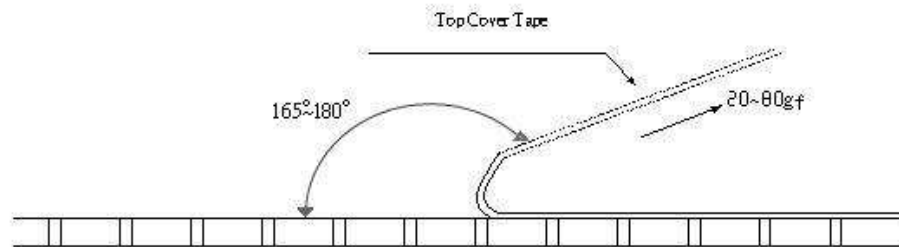

Recommended Land Pattern

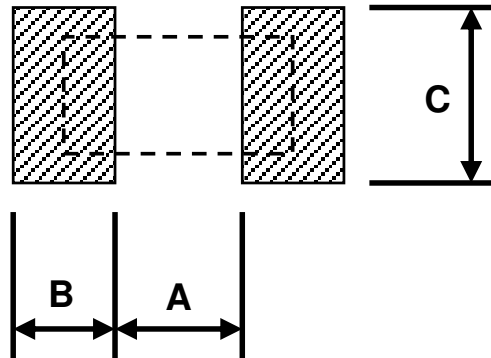

Type	A	B	C
0402	0.50	0.50	0.60±0.2
0603	0.80	1.00	0.90±0.2
AR05	1.00	1.00	1.35±0.2
AR06	2.00	1.15	1.70±0.2
AR13	2.00	1.15	2.50±0.2
AR10	3.60	1.40	2.50±0.2
AR12	4.90	1.60	3.10±0.2

Solder Profile

IR Reflow Soldering

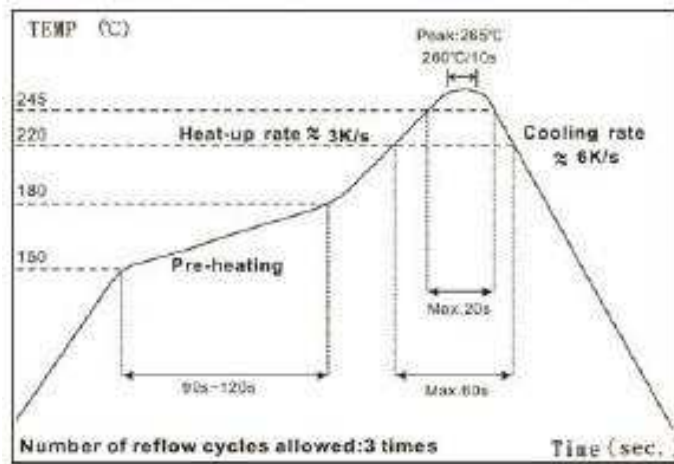

Time of IR reflow soldering at maximum temperature point 260°C : 10s

Wave Soldering (Flow Soldering)

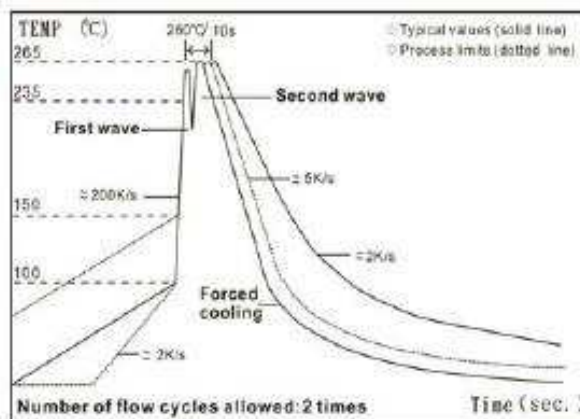

Time of wave soldering at maximum temperature point 260°C : 10s

Hand Soldering

Time of soldering iron at maximum temperature point 410°C : 5s

How To Order

CPF-A	0805	B	1K0	E	1
Common Part	Package Size	Tolerance	Value	TCR	Packaging
CPF-A	0402 1206	B - ±0.1%	100R - 100Ω	E - 25PPM	1 - 1K
Automotive Grade	0603 1210	D - ±0.5%	1K0 -	C - 50PPM	REEL
precision	0805 2010	F - ±1%	1000Ω		Blank -
chip resistor	2512		10K -		5K REEL
			10,000Ω		

X-ON Electronics

Largest Supplier of Electrical and Electronic Components

Click to view similar products for [Thin Film Resistors - SMD category](#):

Click to view products by [TE Connectivity manufacturer](#):

Other Similar products are found below :

[M55342K06B34E0RT3](#) [D55342E07B379BR-TR](#) [AR02BTC1872](#) [AR02BTC18R7](#) [AR02BTC3830](#) [AR02BTC4220](#) [AR02BTC4422](#)
[AR02BTC5100](#) [AR02BTC5111](#) [AR02BTC5762](#) [AR02BTC8251](#) [AR02BTC8452](#) [AR03BTC0110](#) [AR03BTC0120](#) [AR03BTC0330](#)
[AR03BTC0390](#) [AR03BTC1102](#) [AR03BTC1103](#) [AR03BTC1201](#) [AR03BTC2000](#) [AR03BTC2201](#) [AR03BTC2203](#) [AR03BTC2490](#)
[AR03BTC3003](#) [AR03BTC3302](#) [AR03BTC3901](#) [AR03BTC4220](#) [AR03BTC4223N](#) [AR03BTC5602](#) [AR03BTC5603](#) [AR03BTC5900](#)
[AR03BTC7500](#) [AR03BTC9100](#) [AR03BTC9103](#) [AR03BTC9760](#) [AR05BTC0280](#) [AR05BTC1000](#) [AR05BTC1100](#) [AR05BTC1201](#)
[AR05BTC1202](#) [AR05BTC1300](#) [AR05BTC14R3](#) [AR05BTC1500](#) [AR05BTC1523](#) [AR05BTC1620](#) [AR05BTC1622](#) [AR05BTC1623](#)
[AR05BTC1760](#) [AR05BTC1800](#) [AR05BTC1823](#)