

EVC 500 Main Contactor

- Limiting continuous current 500A at 85°C (with 400mcm conductors)
- Hermetically sealed
- UL approved

Typical applications

- DC high voltage high current applications
- Main contactors for hybrid, full battery electric vehicles and fuel-cell cars
- Battery charging systems



3D500_fw5

Contact Data

Contact arrangement	1 Form X (SPST NO DM)
Rated operating voltage	450VDC (450-900VDC) ¹⁾
Continuous carry current ²⁾	500A
85°C, load cable 214mm ² /400mcm	
Limiting short-time current	
85°C, load cable 107mm ² /200mcm	500A / 7.5min 1000A / 1min 2000A / 15s
Make/break current at various voltages	see graph on page 3
Limiting break current, forward direction resistive load, 23°C, 450VDC	1 x 1560A
Load life	see graph on page 3
Initial contact voltage drop at 200A, 30s	<100mV
Operate / release time max.	
close (includes bounce)	20 ³⁾
bounce (after close only)	7
release (includes arcing) at 2000A	12
Mechanical life	>500,000 cycles

- 1) Suitable for voltages up to 450VDC with limited capability to 900VDC.
- 2) Maximum allowed terminal temperatures are: 150°C continuous; 175°C for 2h; 200°C for 2min.
- 3) 20ms (max.) at rated 12V. Consult TE Connectivity for operating time not done at rated voltage.

Coil Data⁴⁾

Economized coil with internal economizer (valid from -40°C to 85°C)

Coil code	Operating voltage range VDC	Inrush current at 23°C A	Max. inrush time ms	Nominal frequency kHz	Nominal duty cycle %
A	9 to 36	3.8	130	19.9	20

Un-economized coil for external economization⁵⁾

Coil code	Rated voltage VDC	Pull-in voltage min. VDC	Pull-in voltage max. VDC	Drop-out voltage max. VDC	Drop-out voltage min. VDC	Min. hold current mA	Coil resistance Ω -5%/+10%
1	12	4.2	6.5	1.5	0.5	650 ⁶⁾	3.14

- 4) All data valid at 23°C coil temperature.
- 5) Un-economized coil must be economized by the customer to avoid overheating.
- 6) Must operate at 12V for 100ms before reducing to minimum holding current.

Coil Data (continued)

Recommended PWM parameters for customer supplied economizer circuit (valid from -40°C to 85°C)

Frequency kHz	Operating voltage range VDC	Coil Current (min. recommended RMS) mA	Duty cycle %	Max. inrush time ms
16 to 20	8.5 to 16	650	20 to 30	200

Insulation Data

Initial dielectric strength ⁷⁾		
between open contacts		2920VDC/leakage <1mA
between contact and coil		2920VDC/leakage <1mA
max. altitude		5000m
Insulation resistance at 500VDC ⁷⁾		
between open contacts		>1 GΩ
between contact and coil		>1 GΩ

- 7) Meets dielectric strength and IR requirements according to ISO 6469-3, conformity to IEC60664-1 in preparation.

Other Data

Material data	
EU RoHS/ELV compliant	
Ambient temperature	-40°C to +85°C
Vibration resistance (functional)	
sine sweep/peak	80-2000Hz/20g
Shock resistance (functional)	
coil energized, peak	50g
Terminal type	stripped wires (coil) and screw (load)
Weight	approx. 430g (0.95lb)

Terminal Assignment

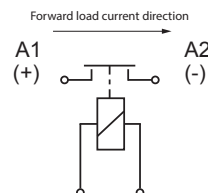

EVC 500 Main Contactor (Continued)

Dimensions

EVC 500 main contactor without coil economizer

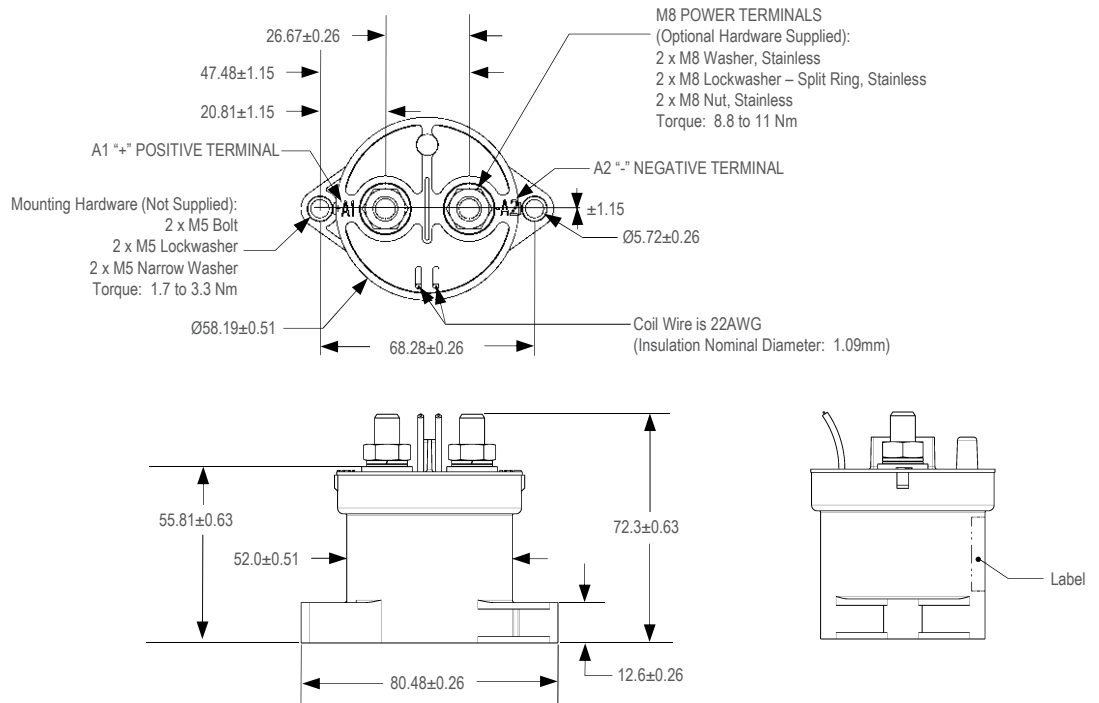

Dimensions

EVC 500 main contactor with internal economizer

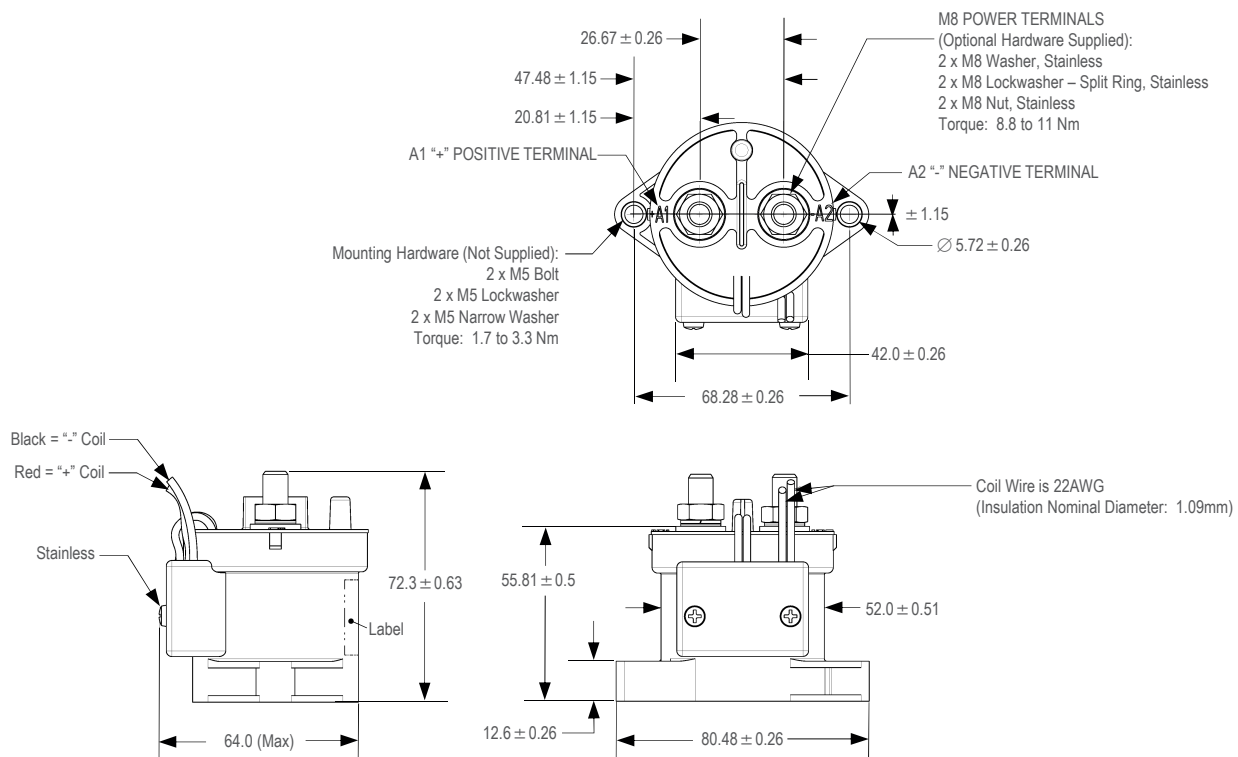

EVC 500 Main Contactor (Continued)

Contact performance

Estimated make and break power switching ratings (forward direction)

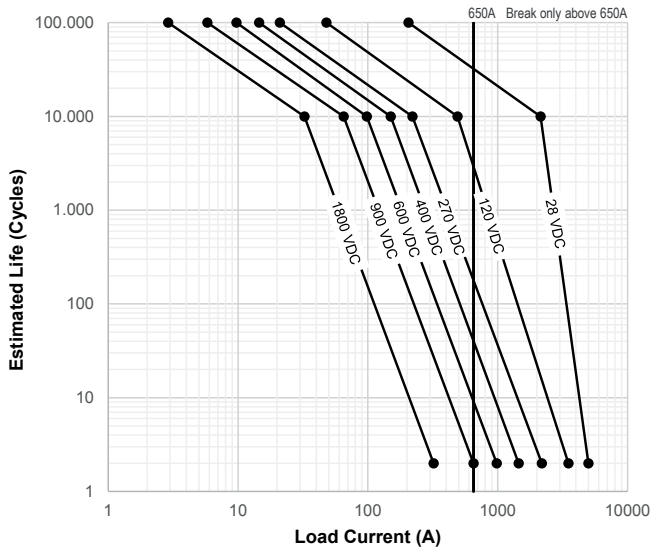

Notes:

- 1) Maximum of 300µH for resistive load. Consult TE Connectivity for inductive loads.
- 2) Estimates based on extrapolated data. Consult TE Connectivity to confirm performance in application.
- 3) End of life when "Insulation Resistance" between terminals falls below 50 MΩ at 500VDC.
- 4) The maximum make current is 650A to avoid contact welding.
- 5) Curves for voltages above maximum rated voltage for information purpose only.
- 6) For reverse current switching capability, please contact TE Connectivity for details.

Contacts closed into capacitor precharge sequence at various time constants

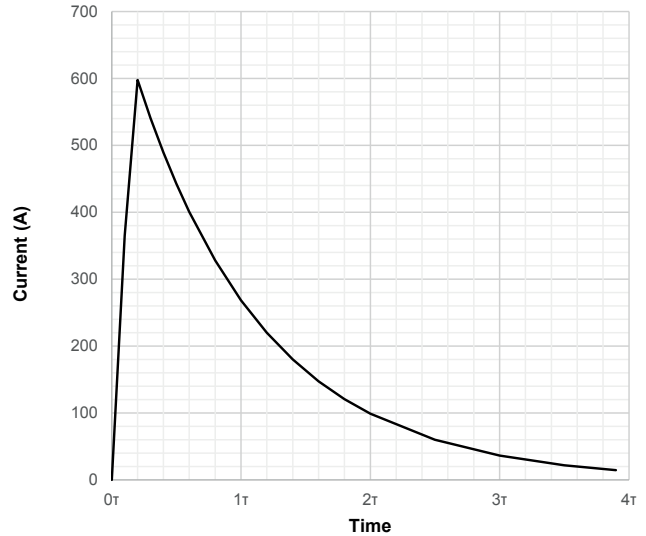

Notes:

- 1) Because higher current cause more damage to contact surface, at least 95% precharge recommended.
- 2) Inrush current dependent upon RC time constant and precharge timing sequence.

Estimated fuse guide for EVC 500 contactors
(Reference only – not to be used for actual fuse sizing)

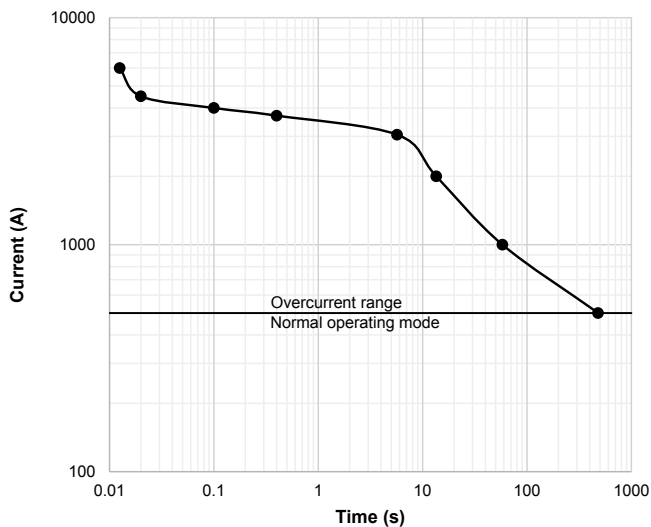

Coil inductance

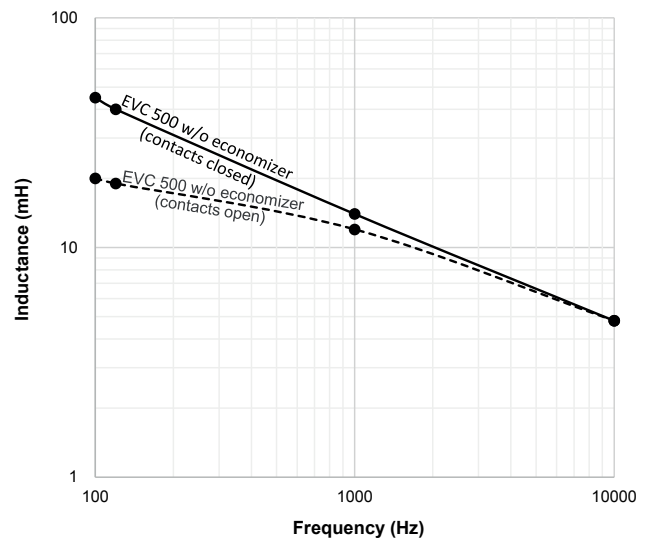

Note:

Data points above were measured using Quadtech 1715 LCR Bridge set 10Ω range, 1V output, measured at 100Hz, 120Hz, 1kHz and 10kHz.



Automotive Relays High Voltage Contactors

EVC 500 Main Contactor (Continued)

Product code structure	Typical product code						EVC 500	-A	1	-A	N	A	M
Type	EVC 500 EVC 500 Main Contactor												
Contact arrangement	A SPST-NO-DM												
Coil system	1 12VDC (requires external economizer)			A 12VDC (internal economizer)									
Coil wire length	A 15.3 inches (390mm)												
Coil termination	N None – stripped wires						C Customer specific connector						
Mounting & power terminals	A Bottom mount & male 10mm x M8 terminals												
Connection hardware (power terminals)	M Connection hardware included						N No connection hardware included						

Production in Americas (only)

Product code	Contact arrang.	Coil	Circuit	Coil suppr.	Relay Type	Resistance	Part number
EVC 500-A1ANAM	SPDT-NO-DM	12VDC	No economizer	External >40V	450VDC	3.14Ω	2098372-1
EVC 500-AAANAM			Internal PWM	Internal			2098190-1

Production in AP (Korea only)

Product code	Contact arrang.	Coil	Circuit	Coil suppr.	Relay Type	Resistance	Part number
EVC 500-A1ANAM	SPDT-NO-DM	12VDC	No economizer	External >40V	450VDC	3.14Ω	2219561-1
EVC 500-AAANAM			Internal PWM	Internal			2299223-2

Production in AP (China only)

Product code	Contact arrang.	Coil	Circuit	Coil suppr.	Relay Type	Resistance	Part number
EVC 500-A1ANAM	SPDT-NO-DM	12VDC	No economizer	External >40V	450VDC	3.14Ω	2327585-1
EVC 500-AAANAM			Internal PWM	Internal			2303096-2
EVC 500-AAACAM-01			Internal PWM with connector	Internal			2303096-1

X-ON Electronics

Largest Supplier of Electrical and Electronic Components

Click to view similar products for [Automotive Relays](#) category:

Click to view products by [TE Connectivity](#) manufacturer:

Other Similar products are found below :

[7-1414968-8](#) [7-1617345-6](#) [9-1617516-5](#) [G5CE1ASIDC12](#) [1393204-2](#) [1393302-3](#) [13Z99A115-0074](#) [1432872-1](#) [AR4-15F11-S01](#) [AR4-15H11](#)
[1617057-2](#) [1617058-6](#) [1617518-5](#) [2-1617057-2](#) [2-1617057-6](#) [2-1617058-3](#) [CB1F-M-12V-H15](#) [898H-1AH-D-001-12VDC](#) [AR4-11F11](#)
[AR4-15F11](#) [AR4-41F11](#) [24198-1](#) [4-1617057-0](#) [41FZ-200ACG-BSL](#) [5-1616920-2](#) [5-1617052-9](#) [5407-0011-HS](#) [CB1AF-M-12V-H59](#) [5-](#)
[1617346-8](#) [103-1AH-C-12VDC](#) [V23134A1052X299](#) [6-1393302-1](#) [897H-1AH-D-R1-U01-12VDC](#) [FTR-P3CP024W1-06](#) [1-1617057-8](#) [3-](#)
[1393305-1](#) [5436-0001-HS](#) [V23086-R1851-A502](#) [V23136-A0004-X075](#) [898H-1AH-D1SW-R1-12VDC](#) [RH4C1P2607](#) [RE031005](#)
[V23134M0052G242](#) [1393204-1](#) [23234B0001X001-EV-144](#) [AZ979-1A-24D](#) [2-1904020-1](#) [V23134B0052C642](#) [V23134B0053C642](#) [V23234-](#)
[A1001-X036](#)