

KHR500 CONTACTOR

"BUBBA II"

600A/28-1000Vdc SPST

Product Features

- Size reduced version of Popular BUBBA series contactors.
- 600A Carry
- SPST Main Contacts, SPDT Auxiliary Contacts
- Bi-Directional Load Switching
- 3300A Break at 400Vdc
- Make Current 4kA
- Available with Integrated PWM Coil Economizer or Dual Coil Electronic "Cut-Throat" Economizer
- Hermetically Sealed- operates in explosive/harsh environments.



PH. 805-220-2020 FAX 805-220-2075
550 LINDEN AVE, CARPINTERIA, CA 93013
www.te.com

PRODUCTION DATA SHEET

11-17-16 Rev

KHR500 Contactor

CAGE CODE

18741

SCALE

NONE

SHEET

1 of 7

Physical Data	Units	KHR500				
Contact Arrangements: Main Contacts		SPST Form X				
Auxiliary Contacts (3A/125Vrms or 1A/30Vdc)		SPDT Form C				
Dimensions	inches	See drawing				
Weight, Nominal	Kg	0.56				

Environmental Data						
Shock, 11ms ½ sine (operating)	G _{peak}	25(Z)/35(X,Y)				
Sine Vibration, 20 G _{peak}	Hz	55-2000				
Random Vibration, 13.3 Grms	Hz	15	100	450	900	2000
		G ² /Hz	.002	.002	.12	.12
Operating/Storage Temperature Range (1)	°C	-55 to +125				
Operating Altitude (max)	ft	70,000				

Electrical Data						
Voltage Rating: Main Contacts (2)	Vdc	28-1000				
Current Rating, Continuous: Main Contacts (1)	A	600A				
Contact Resistance: Main Contacts (3)	mΩ	0.3 max @600A				
	mV	180 max @600A				
Aux Contacts:	mΩ	150@1A				
Hot Switching performance, Resistive Load						
200A make/ break @ 400Vdc	cycles	4000				
600A make/break@400Vdc	cycles	10				
3000A carry/break @ 400 Vdc	cycles	3				
4000A make or pulse through closed contacts (4)	cycles	10				
Mechanical Life (min)	cycles	100,000				
Dielectric Withstand Voltage						
Terminal to Terminal/ Terminals to Coil		1mA max @ 2800 Vrms				
Insulation resistance						
Terminal to Terminal/ Terminals to Coil		100MΩ min @ 500Vdc new 50MΩ min @ 500Vdc end of life				

(1) Ambient conditions and conductor design affect rating. Keep relay terminals below 150C max continuous, 175C max for two hours, and 200C for 1 minute. 170 mm sq. conductor size recommended for 600A carry (2X 3/0 AWG, 350 kcmil). See derating curve for current vs.ambient temperature – operating ambient to +125C allowed with current derating.

(2) Maximum Load Interrupt at 1000Vdc = 100A dc

(3) Stabilized reading. Contact resistance may exceed spec in the first 3 minutes of current carry.

(4) 1ms rise time, 10ms pulse duration.



Kilovac Brand

PH. 805-220-2020 FAX 805-220-2075
550 LINDEN AVE, CARPINTERIA, CA 93013
www.te.com

PRODUCTION DATA SHEET

11-17-16 Rev

KHR500 Contactor

CAGE CODE

18741

SCALE

NONE

SHEET

2 of 7

Coil Data (@ 20 C)

		12V	24V
Nominal/Max Coil Voltage	Vdc	12/16	24/32
Pickup (1)	Vdc	9	13
Hold (min)	Vdc	6	10
Drop Out (max)	Vdc	5	8
Coil Resistance (Pickup/Hold)	Ω	1.3/20	3.2/85
Coil Inrush Current (Max @ Nominal Voltage)	A	5.5	4.5
Holding Current	A	0.63	0.32
Coil Inrush Time (max)	ms	100	100
Timing:			
	Operate Time (typ.)	ms	25
	Operate Bounce (max)	ms	5
	Release time (max)	ms	15
	Simultaneity – Aux/Main(max)	ms	5

(1) Do not operate coil for extended periods at <18Vdc for 24V coil or <9Vdc for 12V coil, as this may damage the economizer low-dropout/hold circuit.

Schematic

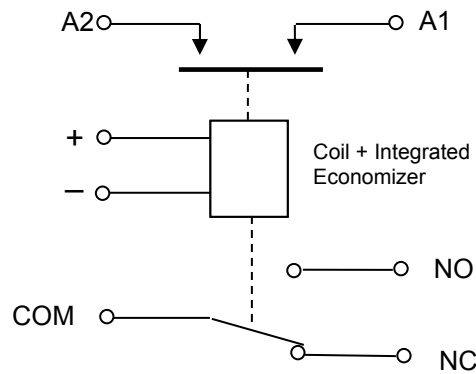

KHR500 (Electronic Cut-Throat Economizer)

Coil Wire: 22 AWG, Red = +, Black = Return

Auxiliary: 22 AWG;

Green = COM

Brown = NO

White = NC



Kilovac Brand

PH. 805-220-2020 FAX 805-220-2075
550 LINDEN AVE, CARPINTERIA, CA 93013
www.te.com

PRODUCTION DATA SHEET

11-17-16 Rev

KHR500 Contactor

CAGE CODE

18741

SCALE

NONE

SHEET

3 of 7

Outline Drawing

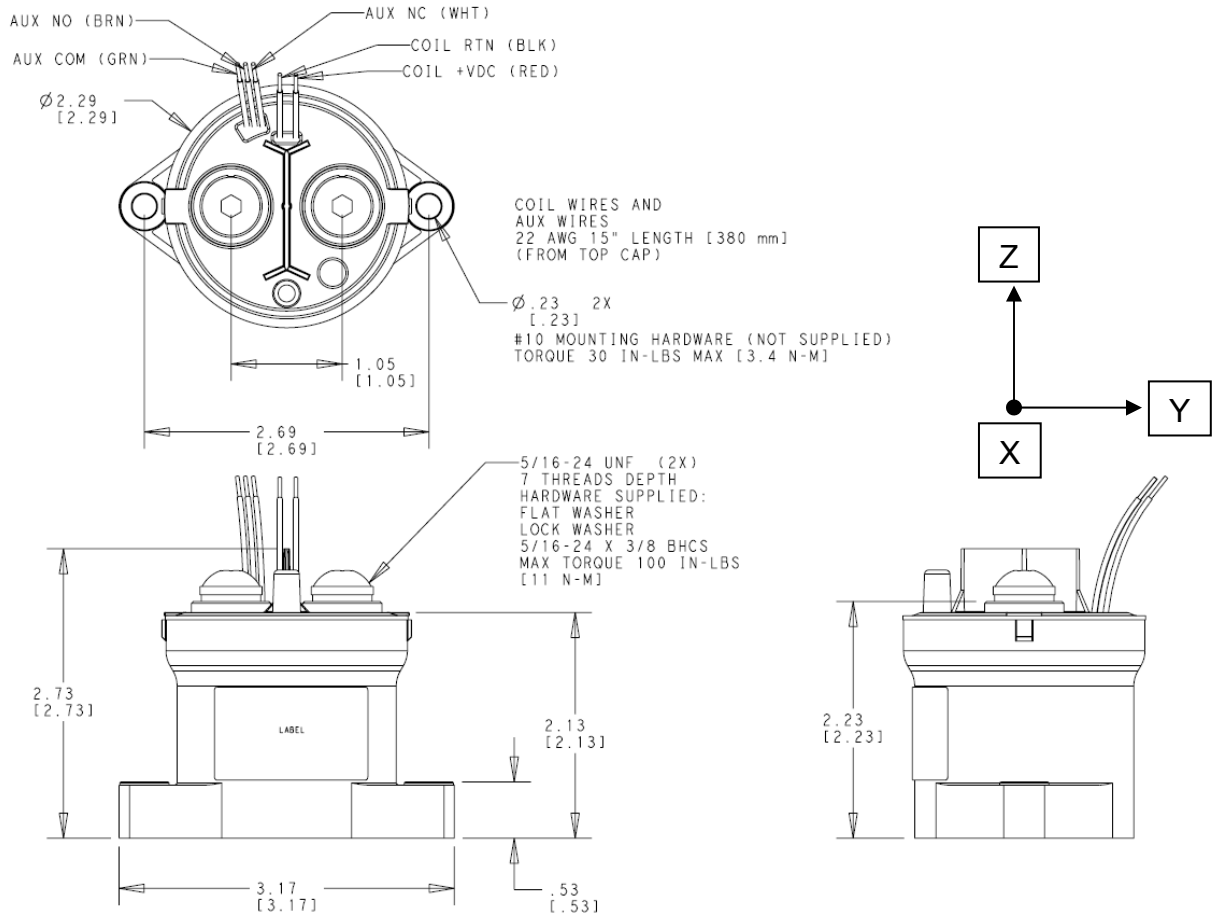

PN Selection

K HR 500 K S A N L

K = Kilovac

HR = High Rupture

500 = Series Designator

K = SPST-NO w/1 SPDT Aux

A = SPST-NO

S = 24-28Vdc Coil Economized

V = 12Vdc Coil Economized

A = 15 inch coil leads

N = No Connector

L = Bottom mount (2X #10 holes)

Female 5/16 X 24 Power Terminals



Kilovac Brand

PRODUCTION DATA SHEET

11-17-16 Rev

KHR500 Contactor

PH. 805-220-2020 FAX 805-220-2075
550 LINDEN AVE, CARPINTERIA, CA 93013
www.te.com

CAGE CODE

18741

SCALE

NONE

SHEET

4 of 7

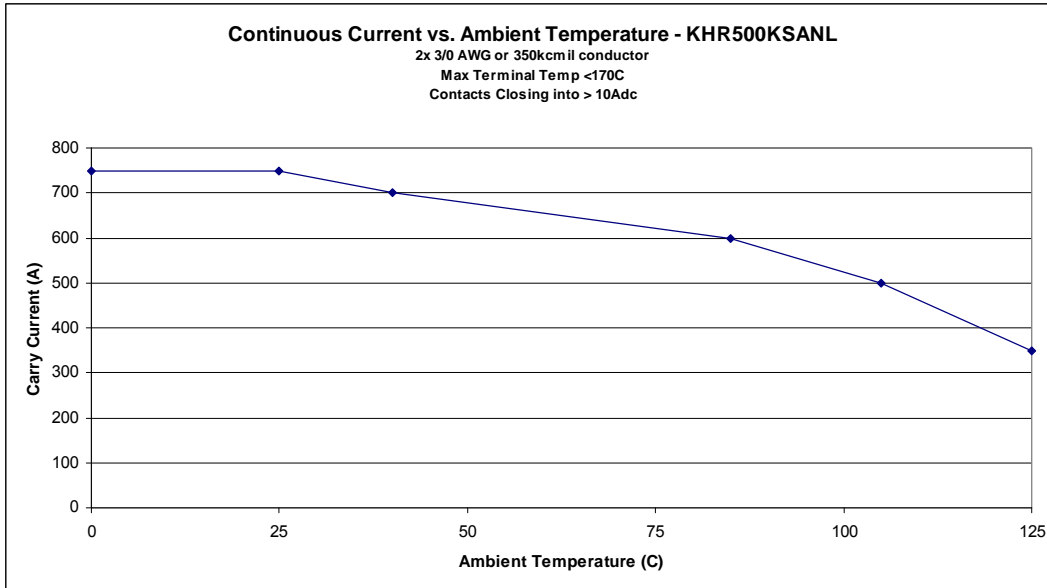

Continuous Current vs. Temperature

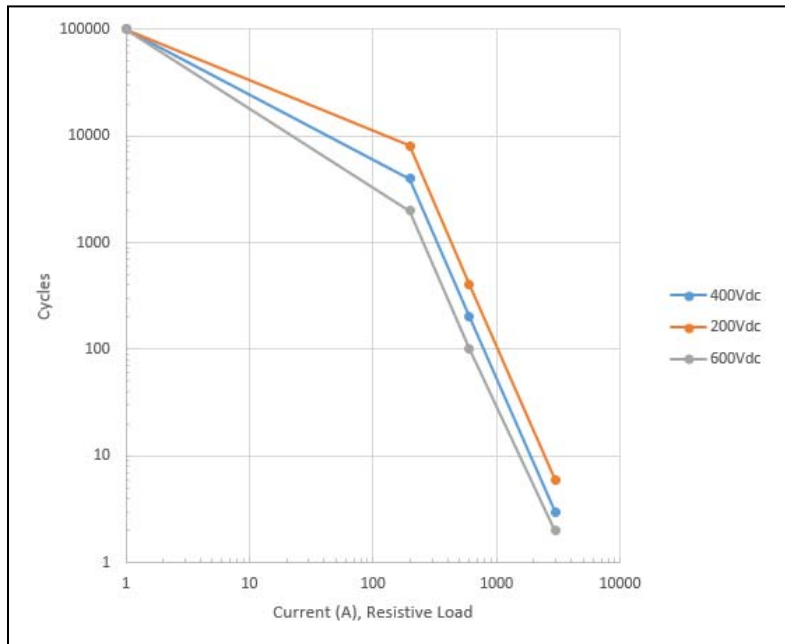

Estimated Load Switching Life vs. Voltage and Current



PRODUCTION DATA SHEET

11-17-16 Rev

PH. 805-220-2020 FAX 805-220-2075
550 LINDEN AVE, CARPINTERIA, CA 93013
www.te.com

KHR500 Contactor

CAGE CODE

18741

SCALE

NONE

SHEET

5 of 7

Application Notes:

Introduction - Product Capabilities And Typical Applications

Kilovac KHR contactors are designed to be the highest performance, smallest and lightest weight, sealed High Voltage contactors in the industry. With current carrying capability of up to 600A and power switching up to 200kW, they are used in a variety of industrial, marine, automotive, and commercial applications. Primarily designed to switch resistive loads, they can be used in a variety of circuit applications bearing in mind a few important considerations. This application note focuses on a few of the more common circuit configurations, and what to consider when selecting, installing and using the contactors.

1. Installation

Kilovac KHR contactors can be mounted in any orientation, and due to the nature of their hermetic seal and isolated enclosure, can be mounted in close proximity to other equipment. However, care must be taken with regard to the termination of the power cables to the main terminals. It is important that the main power connection lugs are mated directly to the terminal seats. Be sure that the hardware stackup is in the proper order, and that washers and other spacers are not placed between the lug and terminal seat. Extraneous connection resistance can cause considerable power dissipation and terminal heating at high current carry. Refer to Figure 1 and Table I for the recommended hardware stackup and torque.

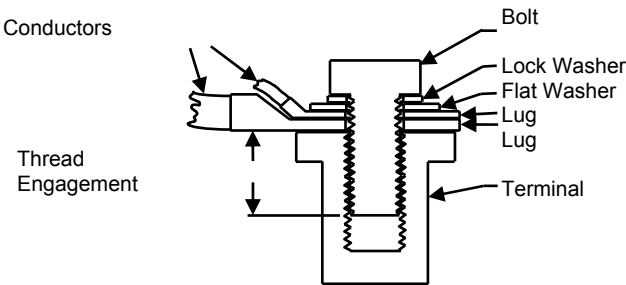

Figure 1
Main Terminal Hardware Installation

Table I

THREAD ENGAGEMENT(turns)	TORQUE
Less than 5	Use longer fastener
5 TO 7	7.9 Nm (70 in-lb.) MAX
7 TO 8	9.0 Nm (80 in-lb.) MAX
8 TO 11	9.0 Nm (80 in-lb.) 11 Nm (100 in-lb.) MAX
Mounting Feet (all)	1.7-3.3 Nm (30-35 in-lb.)

Use the same guidelines and torque maximum values for stud terminal contactors as well.

2. Coils, Drive Circuits and Coil Economizing

Since the power required to close the contacts is generally much greater than the required holding power, Kilovac KHR contactors are packaged with low-profile coils that utilize either an electronic economizer (switch-mode PWM), or mechanical cut-throat economizer. The economizer lets-through the higher power required for contact closure, then reduces the power for holding, greatly reducing the coil power consumption and heating. These circuits are packaged with the contactor, and include coil suppression components as well.

3. Load Types and Power Switching Recommendations

In general, all EV/LEV contactors are designed primarily for connection and interruption of resistive loads and slightly inductive loads ($L/R < 1\text{ms}$). High currents (up to 3000A) can be interrupted in case of circuit faults, and high continuous currents upwards of 600A can be maintained through closed contacts. Some important points to consider are:

- a. Closing into current spikes due to uncharged filter capacitors. Capacitors should be pre-charged whenever possible to avoid excessive contact erosion and nuisance welds. Keep inrush current spikes below 4kA at all times. Care should also be taken when considering other high-inrush loads such as lamps or motors.



PH. 805-220-2020 FAX 805-220-2075
550 LINDEN AVE, CARPINTERIA, CA 93013
www.te.com

PRODUCTION DATA SHEET

11-17-16 Rev

KHR500 Contactor

CAGE CODE	SCALE	SHEET
18741	NONE	6 of 7

b. Large current spikes through closed contacts. Large current spikes through closed contacts in excess of 4000A can sometimes cause spot welding or contact levitation.

c. Circuit inductance. Contactor break-arcs generally last as long as it takes to dissipate the stored inductive energy of the load ($t(\text{arc}) = 1.1 \cdot L/R$).

Longer arcs due to circuit inductance can accelerate contact wear, and in extreme cases, can cause contactor failure. Kilovac recommends that the time constant of the load be less than 1ms for safe operation and maximum life.

Contactors life is a function of the power level switched. Higher make/break currents erode contact materials faster and accelerate loss of dielectric withstanding between the open contacts. The graph on sheet 5 can be used as a guideline for estimating product life at a given load.

4. Recommended Conductor Sizes for Continuous Current Carry

Many sources exist for recommending the proper conductor size for a given current carry. Many of these sources are concerned primarily with wire insulation safety issues. Cable bundling, conduit types, length of runs, etc., are all important considerations. With regard to a contactor placed in line with the conductors, it is important to make sure that the wire size is sufficient such that the contactor terminals themselves do not overheat, leading to a failure of the device. In most cases, the primary path for removal of heat from the contactor terminals is the conductors themselves. Convection to atmosphere and conduction via the base mountings play a lesser role in this type of contactor due to the nature of the construction. 350 kcmil conductor is recommended for maximum carry capabilities over the temperature range.

The recommended maximum power terminal temperature for KHR contactors is 150° C continuous, 175° C for 2 hours and 200C for 1 minute.

5. Auxiliary Circuits

Auxiliary SPDT contacts are available on all KHR models. Auxiliary contacts are rated at 125Vac/ 1A or 30Vdc/3A, with a minimum load of 5Vdc/1mA. Kilovac’s auxiliary contact actuating method will indicate the true position of the main contacts. The auxiliary contact actuation is directly coupled to the main contact moving bridge, and will not indicate “open” unless both contact gaps of the double-make, Form X contact are fully disconnected. Keep in mind that the auxiliary contact is mainly a status indication, and should not be used to directly power other loads such as a relay coil or high power lamp load.

6. Environmental Considerations

All Kilovac contactors are characterized for operation in thermal, vibration, moisture and fluid environments. Refer to the Environmental Data section on sheet 2 for details.



PH. 805-220-2020 FAX 805-220-2075
 550 LINDEN AVE, CARPINTERIA, CA 93013
 www.te.com

PRODUCTION DATA SHEET
 11-17-16 Rev

KHR500 Contactor

CAGE CODE	SCALE	SHEET
18741	NONE	7 of 7

X-ON Electronics

Largest Supplier of Electrical and Electronic Components

Click to view similar products for [Contactors - Electromechanical category:](#)

Click to view products by [TE Connectivity manufacturer:](#)

Other Similar products are found below :

[6-1618400-7](#) [686-117111](#) [686-120111](#) [686-924](#) [686-948](#) [70-901](#) [70-914](#) [MB-3D-6](#) [MC-22A/4-AC120V](#) [8-1616943-9](#) [8-1672124-5](#)
[A40-30-10-84](#) [120-905](#) [A701U](#) [120-904](#) [1393132-9](#) [154-905](#) [154-912](#) [154-913](#) [154-915](#) [154-902](#) [154-910](#) [AVR743D](#) [B6-40-00-84](#) [B7-40-00-84](#) [1616017-5](#) [1616021-1](#) [MVDILM](#) [HP-11D-24](#) [P25-E5019-1](#) [P30C47A12D1-120](#) [P40C47A12D1-120](#) [P40P47D13P1-24-01](#) [CA7-12-10-240](#) [CA7-72-00-24Z](#) [90-162](#) [9-1393132-2](#) [2NC4F0222](#) [A275KXXV2-120VAC](#) [ACC338UMM20](#) [AF80-30-11-13](#) [SZ-B1](#) [CGC-9A-120](#) [3GC2H0M22](#) [3NC0T0A22](#) [3NC1Q0A22](#) [3NC2H0A22](#) [3NC2T0122/SE](#) [3TF3400-0BB4](#) [MC-12B-DC24V](#)