

LOC		DIST		REVISIONS			
P	LTR	DESCRIPTION	DATE	DN	APVD		
D1	REVISED PER	ECO-11-005030	11MAR11	RK	HMR		

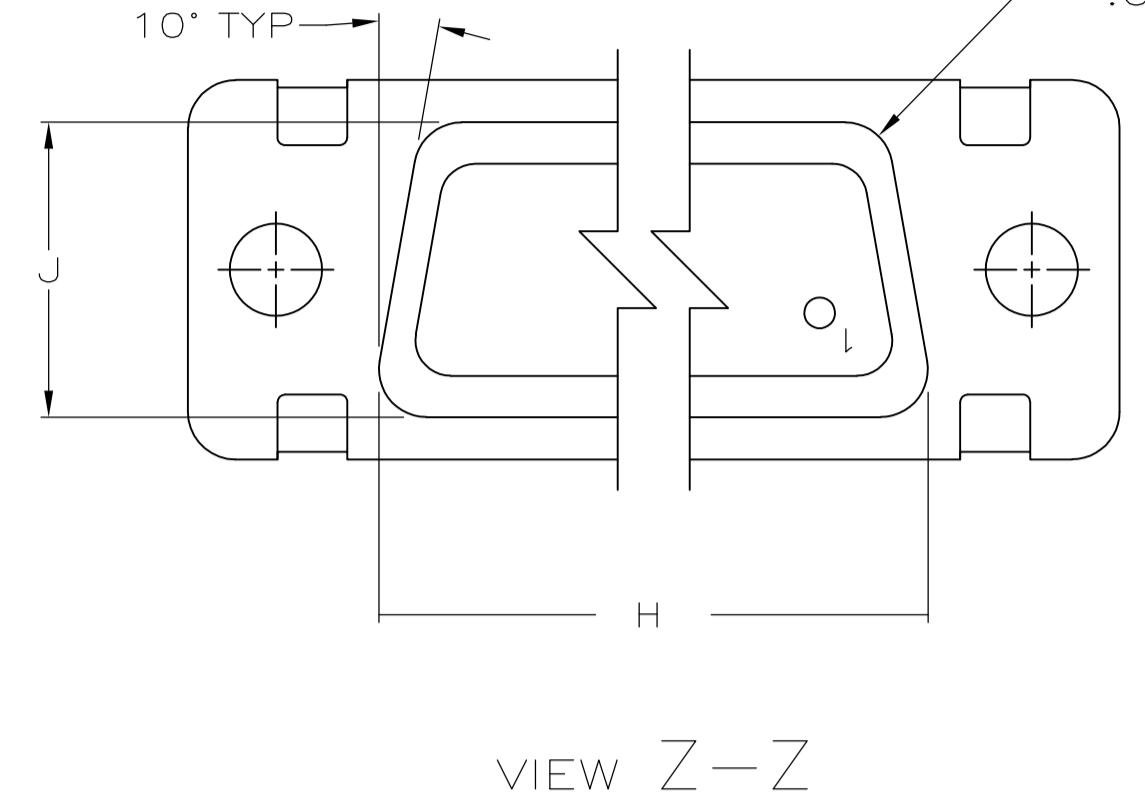
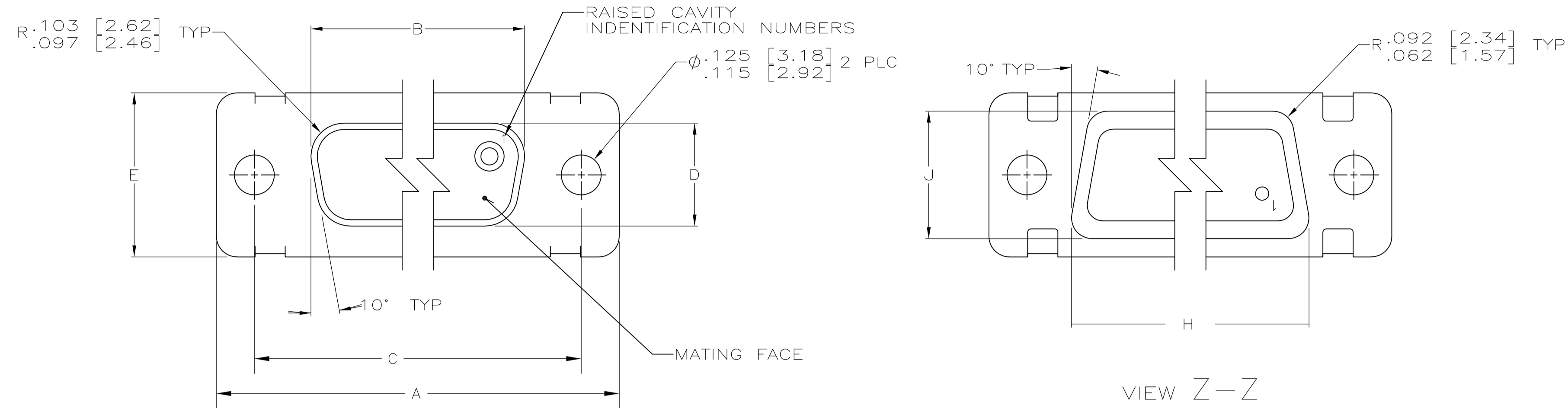

- 1. SEE SHEET 2 FOR RECOMMENDED P.C. BOARD LAYOUT. TRUE POSITION TOLERANCE FOR P.C. BOARD LAYOUT IS .010 [0.25] AT MAX MATERIAL CONDITION. SUGGESTED BOARD THICKNESS IS .125 [3.18]
- 2. THE CONNECTORS DESCRIBED IN THIS DOCUMENT MEET THE REQUIREMENTS OF MIL-C-24308 AND MATE WITH ANY PLUG CONNECTOR WITH SAME INSERT ARRANGEMENT.
- 3. MARK WITH .047 [1.19]-.062 [1.57] HIGH CHARACTERS. FAR SIDE REFERS TO THE WIDE SIDE OF THE KEYSTONE. NEAR SIDE REFERS TO THE NARROW SIDE OF THE KEYSTONE. IF THE REAR SHELL IS TOO SMALL FOR THE ENTIRE MILITARY PART NUMBER, MARKING SHALL BE LOCATED AS FOLLOWS:
 - A. "M24308" ON FRONT SHELL, FAR SIDE.
 - B. SLASH SHEET AND DASH NUMBER ON REAR SHELL, FAR SIDE.
 - C. "AMP" AND DATE CODE ON FRONT SHELL, NEAR SIDE.
 - D. PART NUMBER ON REAR SHELL, NEAR SIDE.

IF THE FRONT SHELL IS TOO SMALL FOR "AMP", PART NUMBER AND DATE CODE, THEN SPLIT AS FOLLOWS:

- A. PART NUMBER ON REAR SHELL, NEAR SIDE.
- B. "AMP" AND DATE CODE ON FRONT SHELL, NEAR SIDE.
- C. MILITARY PART NUMBER ON REAR SHELL, FAR SIDE.

3. MARK AMP, PART NO AND DATE CODE, FAR SIDE.

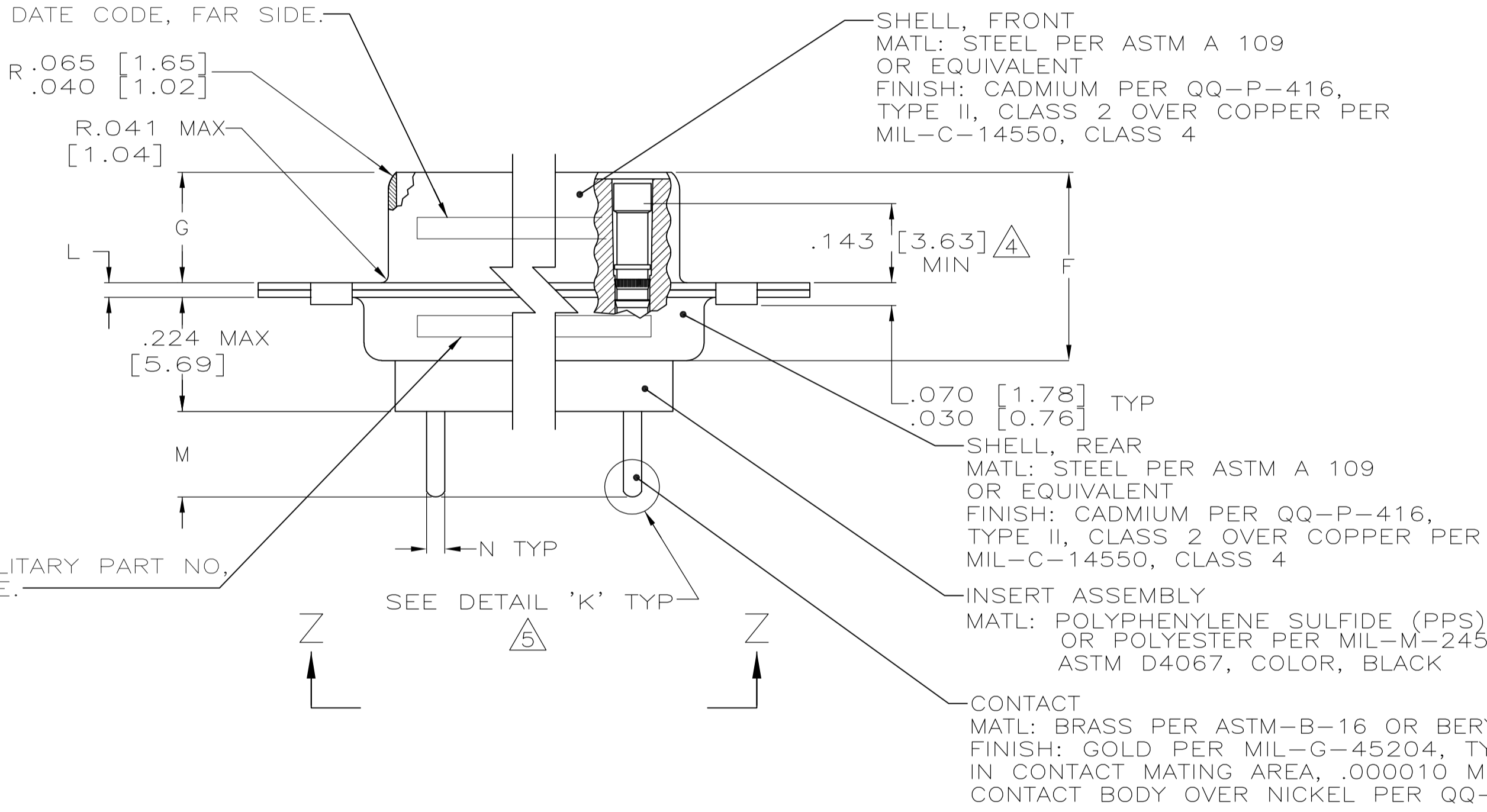

DETAIL K SCALE 8:1

3. MARK MILITARY PART NO, FAR SIDE.

SHELL, FRONT
MATL: STEEL PER ASTM A 109 OR EQUIVALENT
FINISH: CADMIUM PER QQ-P-416, TYPE II, CLASS 2 OVER COPPER PER MIL-C-14550, CLASS 4

SHELL, REAR
MATL: STEEL PER ASTM A 109 OR EQUIVALENT
FINISH: CADMIUM PER QQ-P-416, TYPE II, CLASS 2 OVER COPPER PER MIL-C-14550, CLASS 4

INSERT ASSEMBLY
MATL: POLYPHENYLENE SULFIDE (PPS) PER MIL-M-24519, TYPE: GST-40F OR POLYESTER PER MIL-M-24519, TYPE: GLCP-30F OR PPS PER ASTM D4067, COLOR, BLACK

CONTACT
MATL: BRASS PER ASTM-B-16 OR BERYLLIUM COPPER PER ASTM-B-194
FINISH: GOLD PER MIL-G-45204, TYPE II, GRADE C, CLASS 1
IN CONTACT MATING AREA, .000010 MIN GOLD PER MIL-G-45204 ON CONTACT BODY OVER NICKEL PER QQ-NN-290, .000050 MIN THICK

- 4. POINT OF ELECTRICAL ENGAGEMENT - AS MEASURED WITH A .0390 [0.991]-.0393 [0.998] DIA SQUARE ENDED TEST PIN.
- 5. SOLDER DIP PER MIL-STD-2000 COMPOSITION Sn63 CONFORMING TO QQ-S-571. COVERAGE SHALL BE COMPLETE TO A DISTANCE .020 [0.51] MAX FROM INSERT ASSEMBLY.
- 6. THE SOLDER DIP PROCESS IS PERFORMED SUBSEQUENT TO THE COMPLETION OF PRODUCTION OF THE MILITARY QUALIFIED CONNECTOR. DIMENSIONS APPLY PRIOR TO SOLDER DIPPING.
- 7. SPACERS (QTY 2) ARE SUPPLIED WITH CONNECTORS (NOT ATTACHED TO THE CONNECTOR).
- 8. DIMENSIONS AND TOLERANCES PER ANSI Y14.5M-1982.
- 9. THIS DRAWING SHALL BE INTERPRETED IN ACCORDANCE WITH APPLICABLE STANDARDS LISTED IN MIL-STD-100.

N	M	L	J	H	G	F	E	D	C	B	A	INSERT ARRANGEMENT	NO OF POS	SHELL SIZE	MILITARY P/N ON CONNECTOR	P/N ON CONNECTOR	PART NUMBER		
.033 [0.84] .027 [0.69]	.176 [4.47] .136 [3.45]	.040 [1.02] .020 [0.51]	.544 [13.82] .524 [13.31]	2.188 [55.58] 2.168 [55.07]	.248 [6.30] .238 [6.05]	.439 [11.15] .419 [10.64]	.620 [15.75] .590 [14.99]	.428 [10.87] .418 [10.62]	2.411 [61.24] 2.401 [60.99]	2.069 [52.55] 2.059 [52.30]	2.650 [67.31] 2.620 [66.55]	MS18277-1	50	5	M24308/23-5F	443975-5	1-443975-0		
			2.282 [57.96] 2.262 [57.45]	2.505 [63.63] 2.495 [63.37]			2.164 [54.97] 2.154 [54.71]	2.744 [69.70] 2.714 [68.94]	MS18276-1	37	4	M24308/23-4F	443975-4	443975-9					
.432 [10.97] .412 [10.46]	1.093 [27.76] 1.073 [27.25]	1.635 [41.53] 1.615 [41.02]	.509 [12.93] .479 [12.17]	.316 [8.03] .306 [7.77]	1.857 [47.17] 1.847 [46.91]	1.516 [38.51] 1.506 [38.25]	2.103 [53.42] 2.073 [52.65]	1.317 [33.45] 1.307 [33.20]	.976 [24.79] .966 [24.54]	1.556 [39.52] 1.526 [38.76]	1.889 [47.17] 1.879 [46.91]	1.648 [41.46] 1.638 [41.21]	1.228 [31.19] 1.198 [30.43]	MS18275-1	25	3	M24308/23-3F	443975-3	443975-8
			MS18274-1	15															
.769 [19.53] .749 [19.02]	.033 [0.84] .027 [0.69]	.176 [4.47] .136 [3.45]	.040 [1.02] .020 [0.51]	2.188 [55.58] 2.168 [55.07]	.248 [6.30] .238 [6.05]	.439 [11.15] .419 [10.64]	.620 [15.75] .590 [14.99]	.428 [10.87] .418 [10.62]	2.411 [61.24] 2.401 [60.99]	2.069 [52.55] 2.059 [52.30]	2.650 [67.31] 2.620 [66.55]	MS18273-1	9	1	M24308/23-1F	443975-1	443975-6	443975-5	
																			MS18277-1
.195 MAX [4.95]	.120 REF [3.05]	.033 [0.84] .027 [0.69]	.176 [4.47] .136 [3.45]	.040 [1.02] .020 [0.51]	2.188 [55.58] 2.168 [55.07]	.248 [6.30] .238 [6.05]	.439 [11.15] .419 [10.64]	.620 [15.75] .590 [14.99]	.428 [10.87] .418 [10.62]	2.411 [61.24] 2.401 [60.99]	2.069 [52.55] 2.059 [52.30]	2.650 [67.31] 2.620 [66.55]	MS18276-1	37	4	M24308/23-4F	443975-4	443975-4	
																			MS18275-1
.246±.003 [6.25±0.08]	.120 REF [3.05]	.033 [0.84] .027 [0.69]	.176 [4.47] .136 [3.45]	.040 [1.02] .020 [0.51]	2.188 [55.58] 2.168 [55.07]	.248 [6.30] .238 [6.05]	.439 [11.15] .419 [10.64]	.620 [15.75] .590 [14.99]	.428 [10.87] .418 [10.62]	2.411 [61.24] 2.401 [60.99]	2.069 [52.55] 2.059 [52.30]	2.650 [67.31] 2.620 [66.55]	MS18274-1	15	2	M24308/23-2F	443975-2	443975-2	
																			MS18273-1

SPACER
MATL: ALUMINUM ALLOY PER ASTM B 211
FINISH: IRIDITE PER MIL-C-5541, CLASS 3, COLOR GOLD

THIS DRAWING IS A CONTROLLED DOCUMENT.

STE TE Connectivity

AMPLIMITE RECEPTACLE ASSY W/ SIZE 20 POSTED PC BOARD CONTACTS SERIES 109, SIZES 1 THRU 5

00779-443975

SCALE 4:1 SHEET 1 OF 2 REV D1

LOC	DIST	REV	DATE	BY	APPV
DF	DO				

REVISIONS		DATE	BY	APPV
P	LTR			
- SEE SHEET 1				

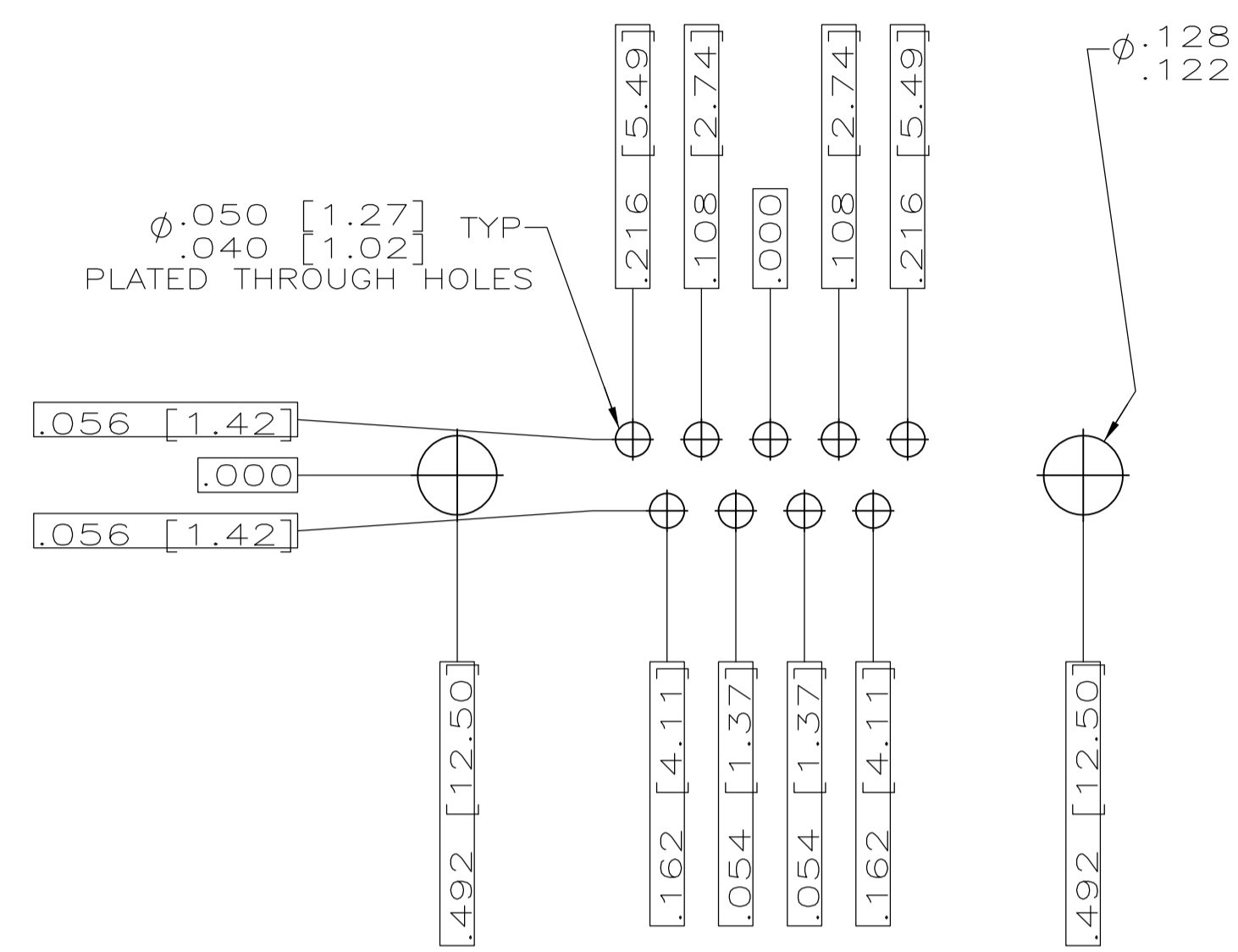

RECOMMENDED P.C. BOARD LAYOUT
SHELL SIZE 1 (9 POSITION) Δ

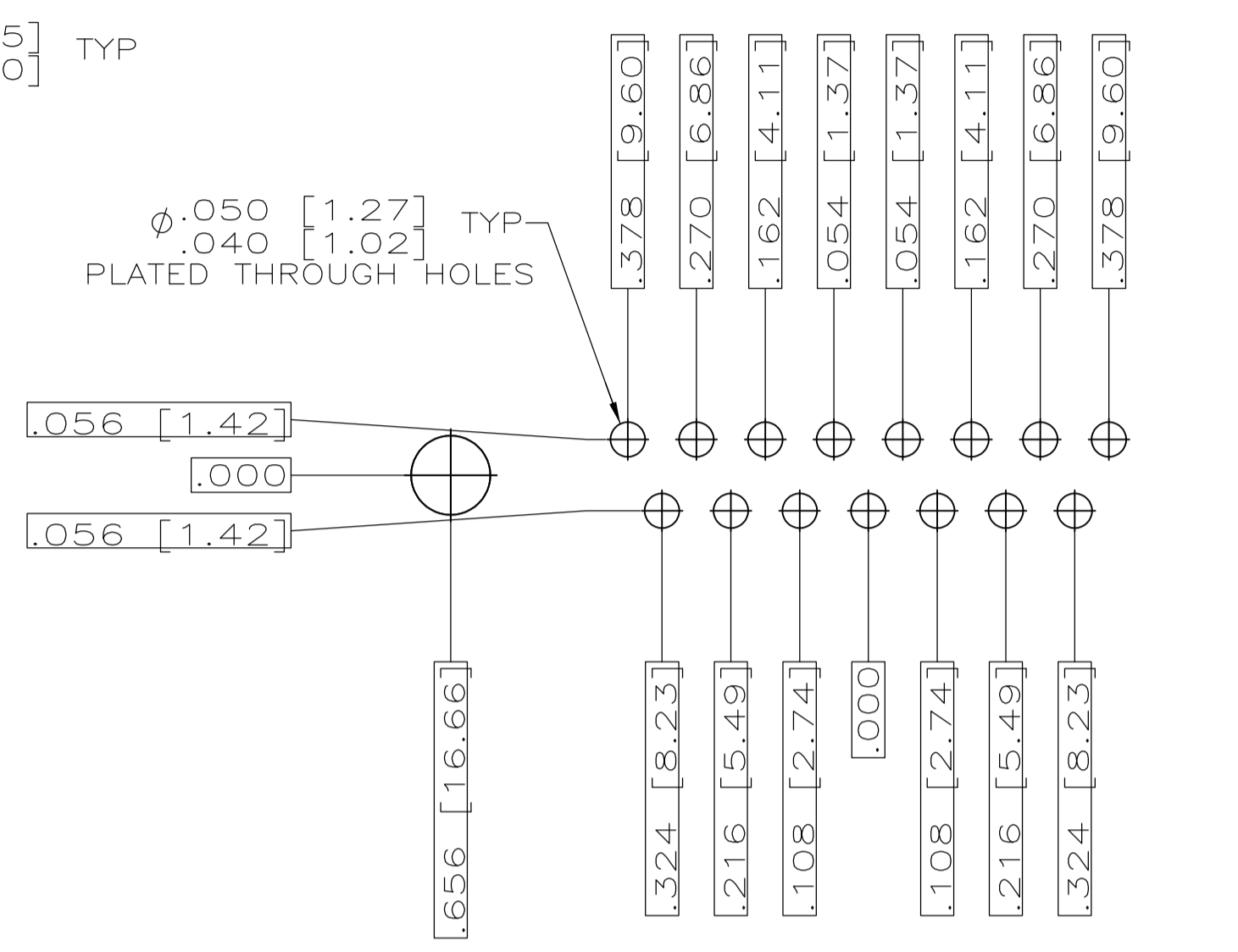

RECOMMENDED P.C. BOARD LAYOUT
SHELL SIZE 2 (15 POSITION) Δ

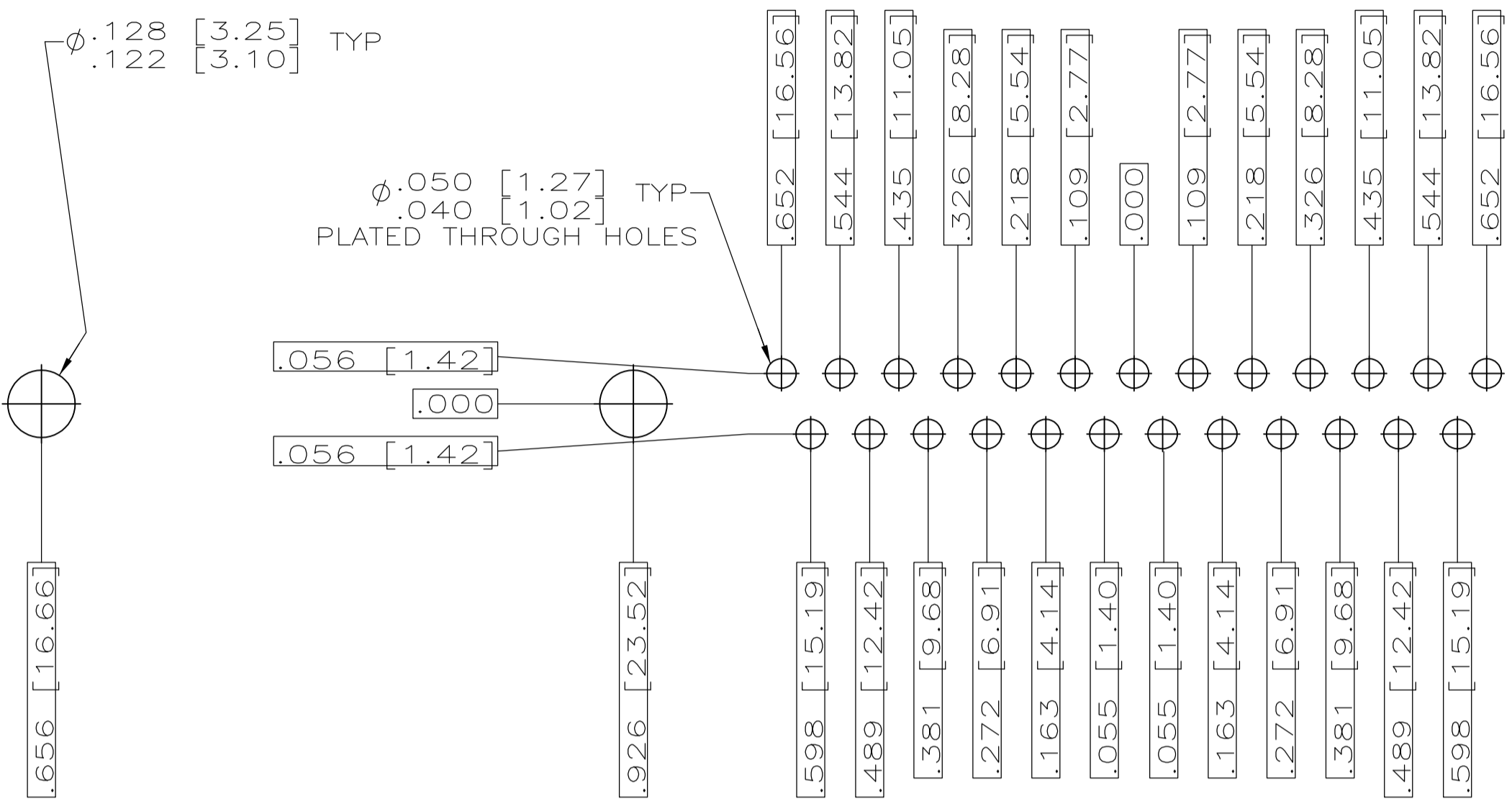

RECOMMENDED P.C. BOARD LAYOUT
SHELL SIZE 3 (25 POSITION) Δ

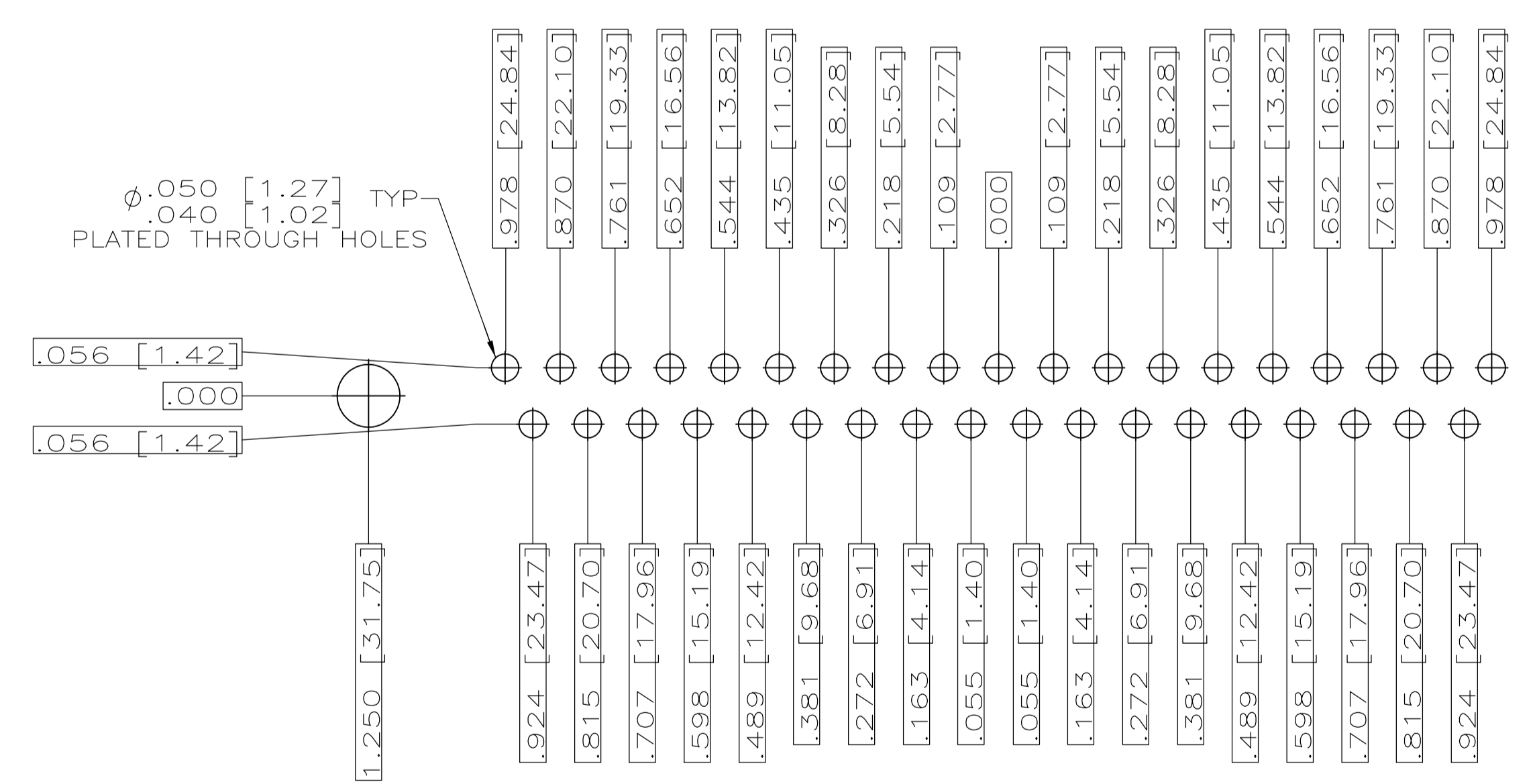

RECOMMENDED P.C. BOARD LAYOUT
SHELL SIZE 4 (37 POSITION) Δ

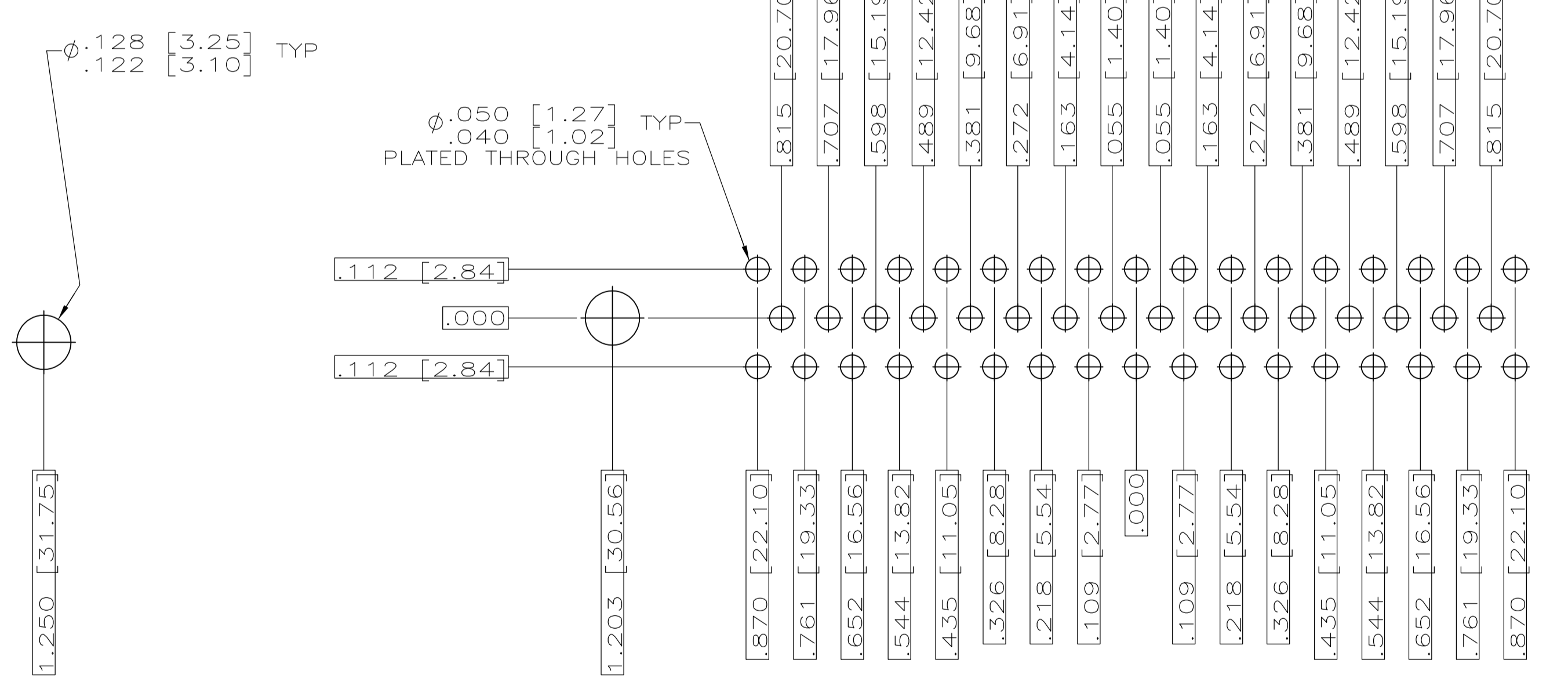

RECOMMENDED P.C. BOARD LAYOUT
SHELL SIZE 5 (50 POSITION) Δ

THIS DRAWING IS A CONTROLLED DOCUMENT.		DWN J.A.Baker	OSMAY97	STE TE Connectivity
		DRW G. OVER	15MAY98	
DIMENSIONS: INCHES	TOLERANCES UNLESS OTHERWISE SPECIFIED:	NAME		AMPLIMITE RECEPTACLE ASSY WITH SIZE 20 STRAIGHT POSTED P.C. BOARD CONTACTS, SERIES 109.
		PRODUCT SPEC MIL-C-24308		
		APPLICATION SPEC		SIZE: CAGE CODE: DRAWING NO: RESTRICTED TO
MATERIAL SEE CALLOUTS	FINISH SEE CALLOUTS	WEIGHT		A1 00779 C-443975
		CUSTOMER DRAWING		SCALE: 4:1 SHEET 2 OF 2 REV D1

X-ON Electronics

Largest Supplier of Electrical and Electronic Components

Click to view similar products for [D-Sub MIL Spec Connectors](#) category:

Click to view products by [TE Connectivity](#) manufacturer:

Other Similar products are found below :

[M85049/50-5F](#) [D38999/24WG11PB-LC](#) [MDM-9SH006A](#) [850-056-0812](#) [1218697-4](#) [D38999/26WJ61PC L/C](#) [1484349-1](#) [17D25HV](#)
[1996840-1](#) [243082-15](#) [1757682-1](#) [17D-E51218-1](#) [17SDA15S](#) [1883533-1](#) [1883886-1](#) [1883889-1](#) [192900-0377](#) [M24308/8-347](#) [M83513/03-](#)
[E09C](#) [443961-3](#) [5-1218949-1](#) [550-031NF1R6K](#) [3-1236089-2](#) [550E001NF1R3J0L](#) [550T001NF1R6K0L](#) [557T283NF5B08](#) [DC121073157](#)
[443869-3](#) [443869-4](#) [443869-5](#) [550S004NF1R1B0F03](#) [557E283NF1A06](#) [527-019NF0303R2K1F](#) [5-446405-1](#) [550-031NF1R2E](#)
[550E003M2R9J0F04](#) [550E003M3R9J0F05](#) [550E024M104R9J0](#) [550E024NF102R3J0B](#) [550E039NF1R3J1-02](#) [550S003M3R9B0F05](#)
[550S004M4R7M0F04](#) [550S004NF1R1B1F02](#) [550S008M3F0K0F04](#) [550S086M5R3J0L](#) [550S100NF3F0E](#) [550T001M2R7E0L](#)
[550T001NF1F0B1L](#) [550T001NF1R1K0G](#) [550T001NF1R3K0G](#)