

LOC		DIST		REVISIONS			
P	LTR	DESCRIPTION	DATE	DN	APVD		
D1	REVISED PER	ECO-11-005030	11MAR11	RK	HMR		

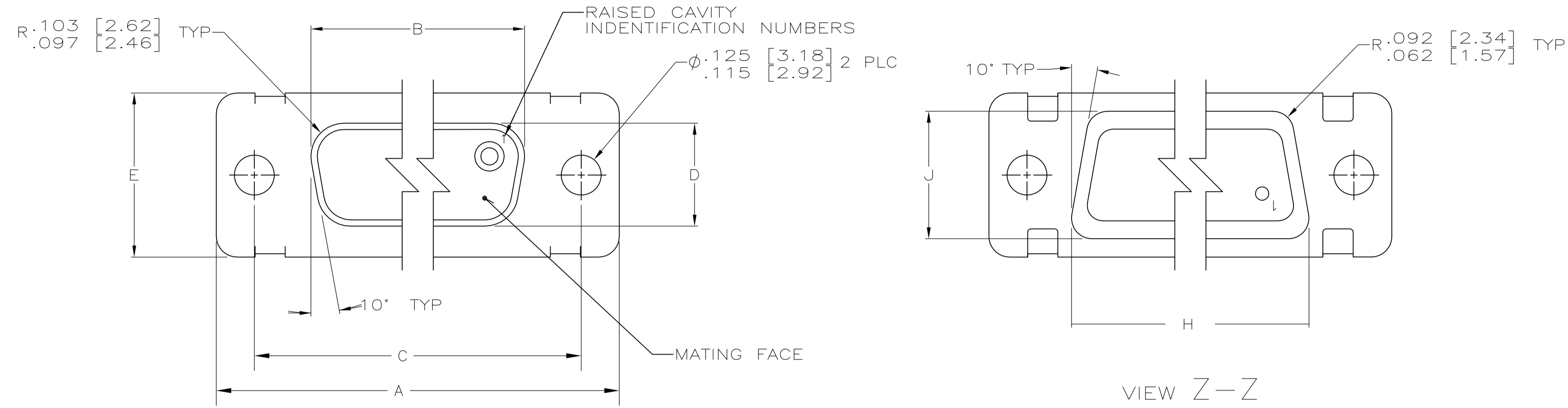

- SEE SHEET 2 FOR RECOMMENDED P.C. BOARD LAYOUT. TRUE POSITION TOLERANCE FOR P.C. BOARD LAYOUT IS .010 [0.25] AT MAX MATERIAL CONDITION. SUGGESTED BOARD THICKNESS IS .125 [3.18]
- THE CONNECTORS DESCRIBED IN THIS DOCUMENT MEET THE REQUIREMENTS OF MIL-C-24308 AND MATE WITH ANY PLUG CONNECTOR WITH SAME INSERT ARRANGEMENT.
- MARK WITH .047 [1.19]-.062 [1.57] HIGH CHARACTERS. FAR SIDE REFERS TO THE WIDE SIDE OF THE KEYSTONE. NEAR SIDE REFERS TO THE NARROW SIDE OF THE KEYSTONE. IF THE REAR SHELL IS TOO SMALL FOR THE ENTIRE MILITARY PART NUMBER, MARKING SHALL BE LOCATED AS FOLLOWS:
 - "M24308" ON FRONT SHELL, FAR SIDE.
 - SLASH SHEET AND DASH NUMBER ON REAR SHELL, FAR SIDE.
 - "AMP" AND DATE CODE ON FRONT SHELL, NEAR SIDE.
 - PART NUMBER ON REAR SHELL, NEAR SIDE.
 IF THE FRONT SHELL IS TOO SMALL FOR "AMP", PART NUMBER AND DATE CODE, THEN SPLIT AS FOLLOWS:
 - PART NUMBER ON REAR SHELL, NEAR SIDE.
 - "AMP" AND DATE CODE ON FRONT SHELL, NEAR SIDE.
 - MILITARY PART NUMBER ON REAR SHELL, FAR SIDE.

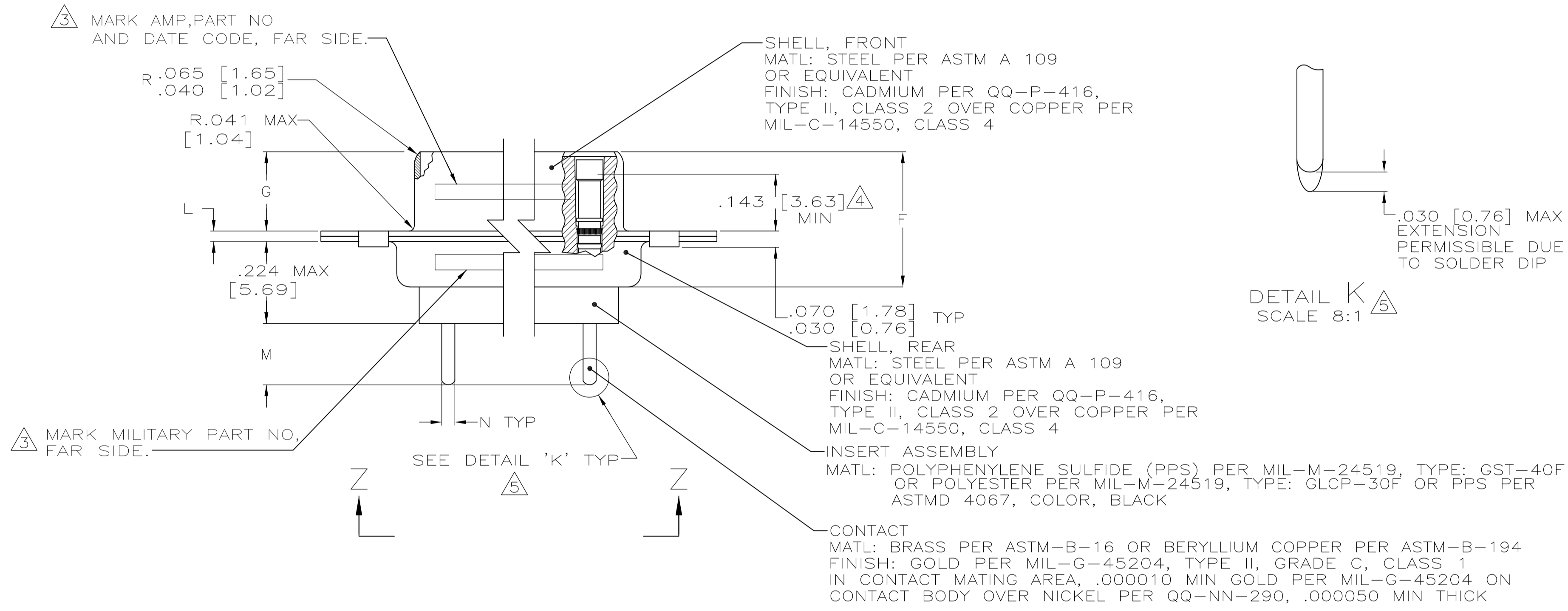

- POINT OF ELECTRICAL ENGAGEMENT - AS MEASURED WITH A .0390 [0.991]-.0393 [0.998] DIA SQUARE ENDED TEST PIN.
- SOLDER DIP PER MIL-STD-2000 COMPOSITION Sn63 CONFORMING TO QQ-S-571. COVERAGE SHALL BE COMPLETE TO A DISTANCE .020 [0.51] MAX FROM INSERT ASSEMBLY.
- THE SOLDER DIP PROCESS IS PERFORMED SUBSEQUENT TO THE COMPLETION OF PRODUCTION OF THE MILITARY QUALIFIED CONNECTOR. DIMENSIONS APPLY PRIOR TO SOLDER DIPPING.
- SPACERS (QTY 2) ARE SUPPLIED WITH CONNECTORS (NOT ATTACHED TO THE CONNECTOR).
- DIMENSIONS AND TOLERANCES PER ANSI Y14.5M-1982.
- THIS DRAWING SHALL BE INTERPRETED IN ACCORDANCE WITH APPLICABLE STANDARDS LISTED IN MIL-STD-100.

N	M	L	J	H	G	F	E	D	C	B	A	INSERT ARRANGEMENT	NO OF POS	SHELL SIZE	MILITARY P/N ON CONNECTOR	P/N ON CONNECTOR	PART NUMBER
.033 [0.84] .027 [0.69]	.208 [5.28] .168 [4.27]	.040 [1.02] .020 [0.51]	.544 [13.82] .524 [13.31]	2.188 [55.58] 2.168 [55.07]	.248 [6.30] .238 [6.05]	.439 [11.15] .419 [10.64]	.620 [15.75] .590 [14.99]	.428 [10.87] .418 [10.62]	2.411 [61.24] 2.401 [60.99]	2.069 [52.55] 2.059 [52.30]	2.650 [67.31] 2.620 [66.55]	MS18277-1	50	5	M24308/23-11F	443976-5	1-443976-0
			2.282 [57.96] 2.262 [57.45]	2.505 [63.63] 2.495 [63.37]			2.164 [54.97] 2.154 [54.71]	2.744 [69.70] 2.714 [68.94]	MS18276-1	37	4	M24308/23-10F	443976-4	443976-9			
			1.635 [41.53] 1.615 [41.02]	1.857 [47.17] 1.847 [46.91]			1.516 [38.51] 1.506 [38.25]	2.103 [53.42] 2.073 [52.65]	MS18275-1	25	3	M24308/23-9F	443976-3	443976-8			
			1.093 [27.76] 1.073 [27.25]	1.317 [33.45] 1.307 [33.20]			.976 [24.79] .966 [24.54]	1.556 [39.52] 1.526 [38.76]	MS18274-1	15	2	M24308/23-8F	443976-2	443976-7			
.033 [0.84] .027 [0.69]	.208 [5.28] .168 [4.27]	.040 [1.02] .020 [0.51]	.749 [19.02]	2.188 [55.58] 2.168 [55.07]	.248 [6.30] .238 [6.05]	.439 [11.15] .419 [10.64]	.620 [15.75] .590 [14.99]	.428 [10.87] .418 [10.62]	2.411 [61.24] 2.401 [60.99]	2.069 [52.55] 2.059 [52.30]	2.650 [67.31] 2.620 [66.55]	MS18277-1	50	5	M24308/23-11F	443976-5	443976-5
			2.282 [57.96] 2.262 [57.45]	2.505 [63.63] 2.495 [63.37]			2.164 [54.97] 2.154 [54.71]	2.744 [69.70] 2.714 [68.94]	MS18276-1	37	4	M24308/23-10F	443976-4	443976-4			
			1.635 [41.53] 1.615 [41.02]	1.857 [47.17] 1.847 [46.91]			1.516 [38.51] 1.506 [38.25]	2.103 [53.42] 2.073 [52.65]	MS18275-1	25	3	M24308/23-9F	443976-3	443976-3			
			1.093 [27.76] 1.073 [27.25]	1.317 [33.45] 1.307 [33.20]			.976 [24.79] .966 [24.54]	1.556 [39.52] 1.526 [38.76]	MS18274-1	15	2	M24308/23-8F	443976-2	443976-2			
.033 [0.84] .027 [0.69]	.208 [5.28] .168 [4.27]	.040 [1.02] .020 [0.51]	.749 [19.02]	2.188 [55.58] 2.168 [55.07]	.248 [6.30] .238 [6.05]	.439 [11.15] .419 [10.64]	.620 [15.75] .590 [14.99]	.428 [10.87] .418 [10.62]	2.411 [61.24] 2.401 [60.99]	2.069 [52.55] 2.059 [52.30]	2.650 [67.31] 2.620 [66.55]	MS18277-1	50	5	M24308/23-11F	443976-5	443976-1
			2.282 [57.96] 2.262 [57.45]	2.505 [63.63] 2.495 [63.37]			2.164 [54.97] 2.154 [54.71]	2.744 [69.70] 2.714 [68.94]	MS18276-1	37	4	M24308/23-10F	443976-4	443976-4			
			1.635 [41.53] 1.615 [41.02]	1.857 [47.17] 1.847 [46.91]			1.516 [38.51] 1.506 [38.25]	2.103 [53.42] 2.073 [52.65]	MS18275-1	25	3	M24308/23-9F	443976-3	443976-3			
			1.093 [27.76] 1.073 [27.25]	1.317 [33.45] 1.307 [33.20]			.976 [24.79] .966 [24.54]	1.556 [39.52] 1.526 [38.76]	MS18274-1	15	2	M24308/23-8F	443976-2	443976-1			

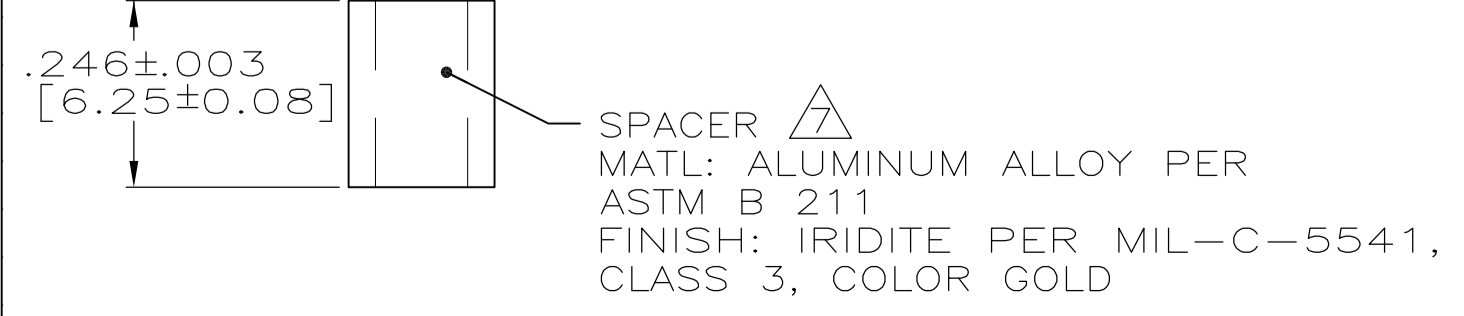
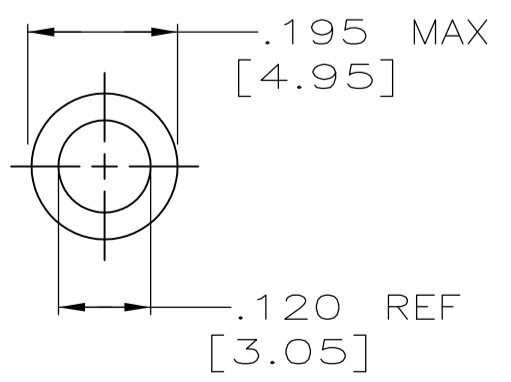

THIS DRAWING IS A CONTROLLED DOCUMENT.		DIN J.A. BAKER DSMAY97		STE TE Connectivity	
DIMENSIONS: INCHES	TOLERANCES UNLESS OTHERWISE SPECIFIED:	APVD	NAME	PRODUCT SPEC	RESTRICTED TO
0 PLC ± -	1 PLC ± -	---	---	---	---
2 PLC ± -	3 PLC ± -	---	---	---	---
4 PLC ± -	ANGLES ± -	---	---	---	---
MATERIAL	FINISH	WEIGHT	SIZE	CAGE CODE	DRAWING NO
---	---	---	A1	00779	443976
CUSTOMER DRAWING			SCALE	SHEET	REV
			4:1	1 OF 2	D1

LOC	DIST	REV	DATE	BY	APPV
DF	D0				

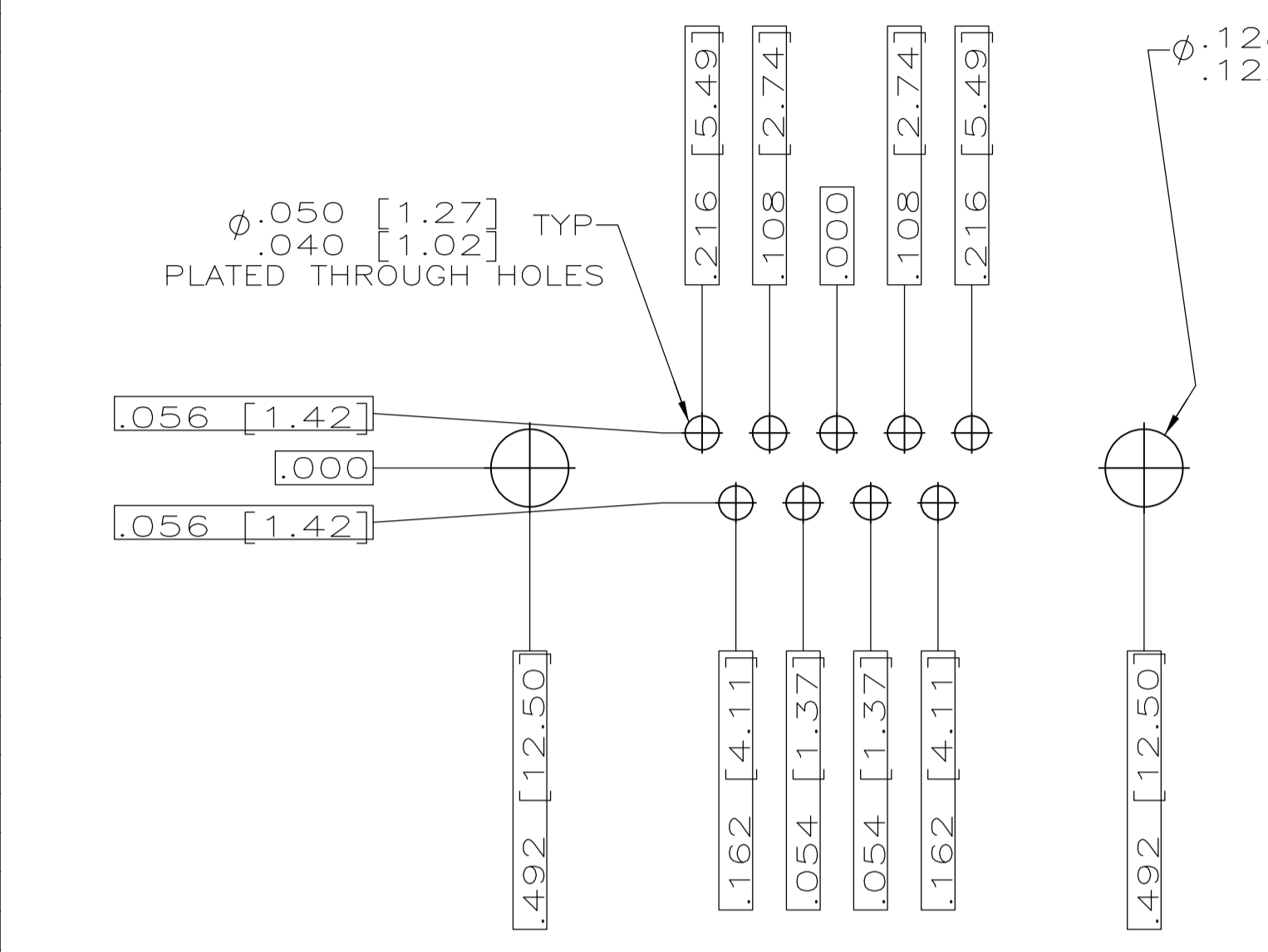

RECOMMENDED P.C. BOARD LAYOUT
SHELL SIZE 1 (9 POSITION) ▲

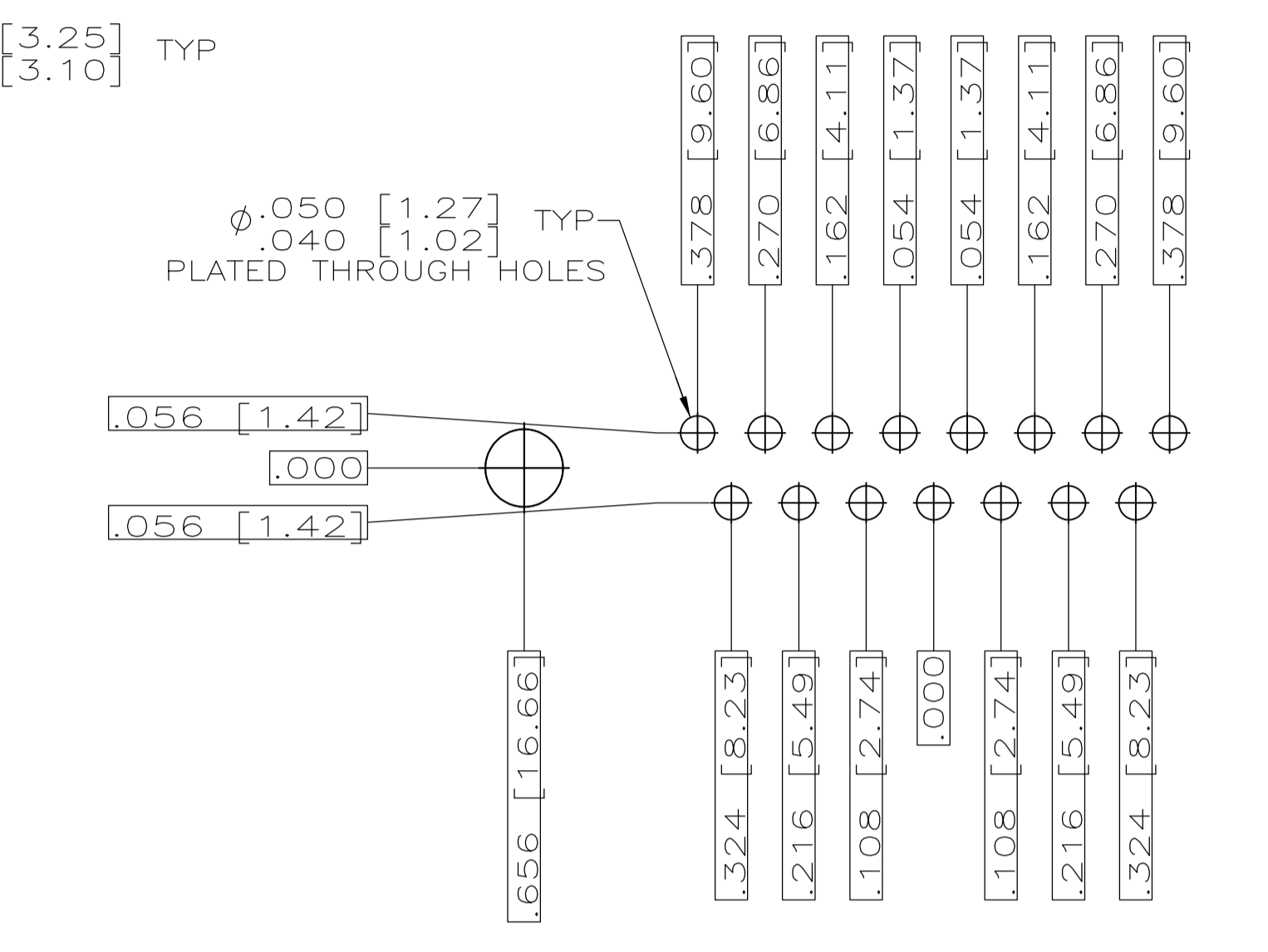

RECOMMENDED P.C. BOARD LAYOUT
SHELL SIZE 2 (15 POSITION) ▲

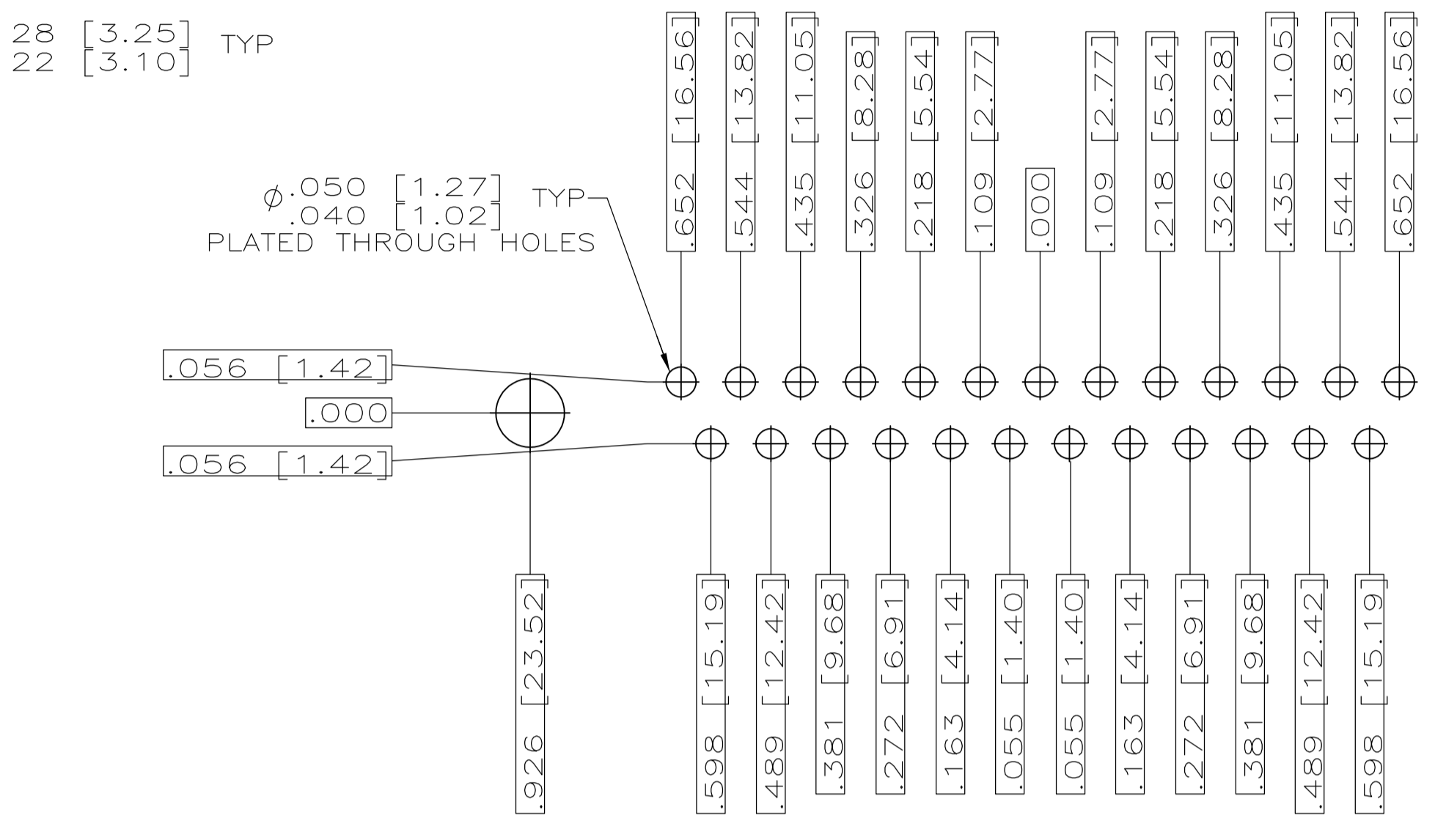

RECOMMENDED P.C. BOARD LAYOUT
SHELL SIZE 3 (25 POSITION) ▲

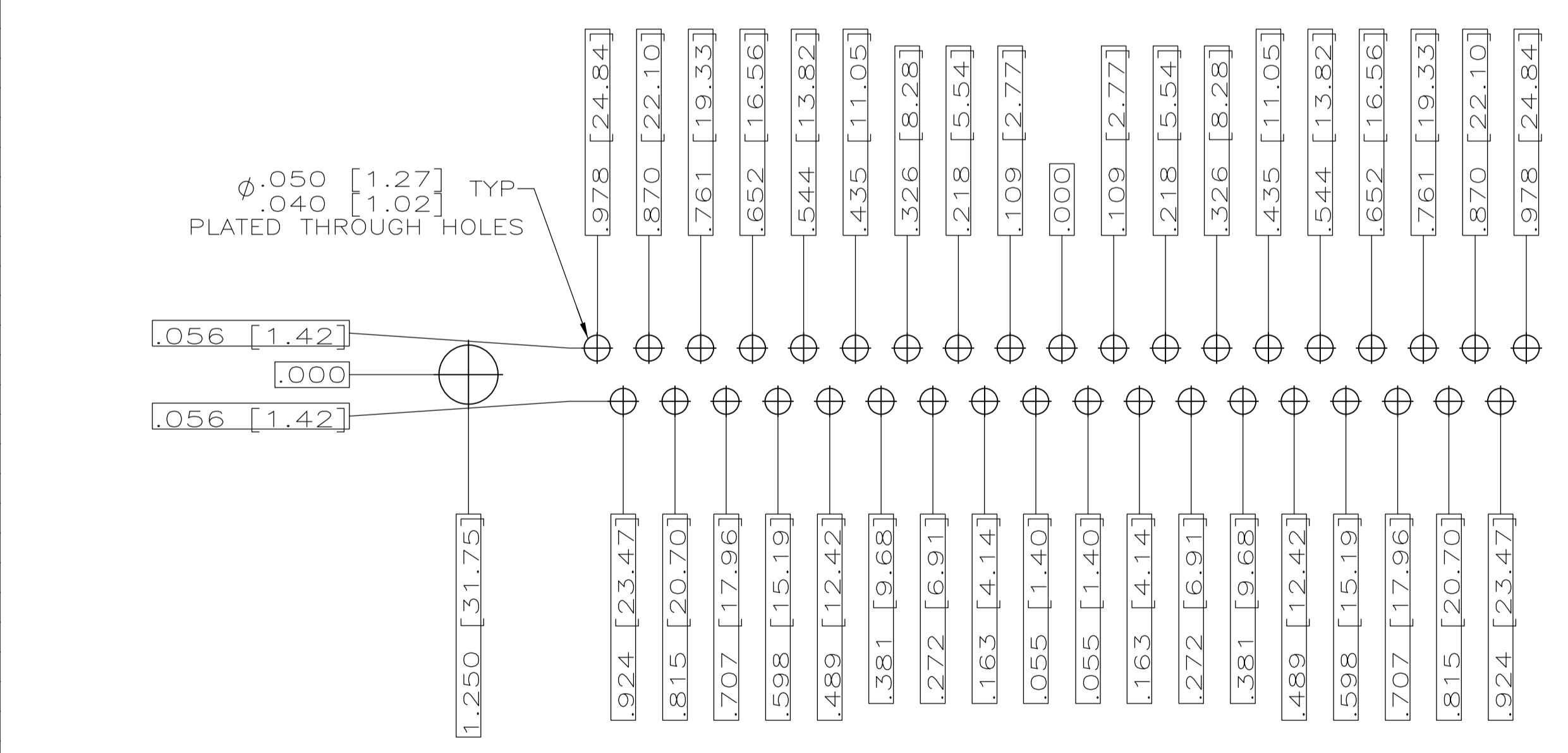

RECOMMENDED P.C. BOARD LAYOUT
SHELL SIZE 4 (37 POSITION) ▲

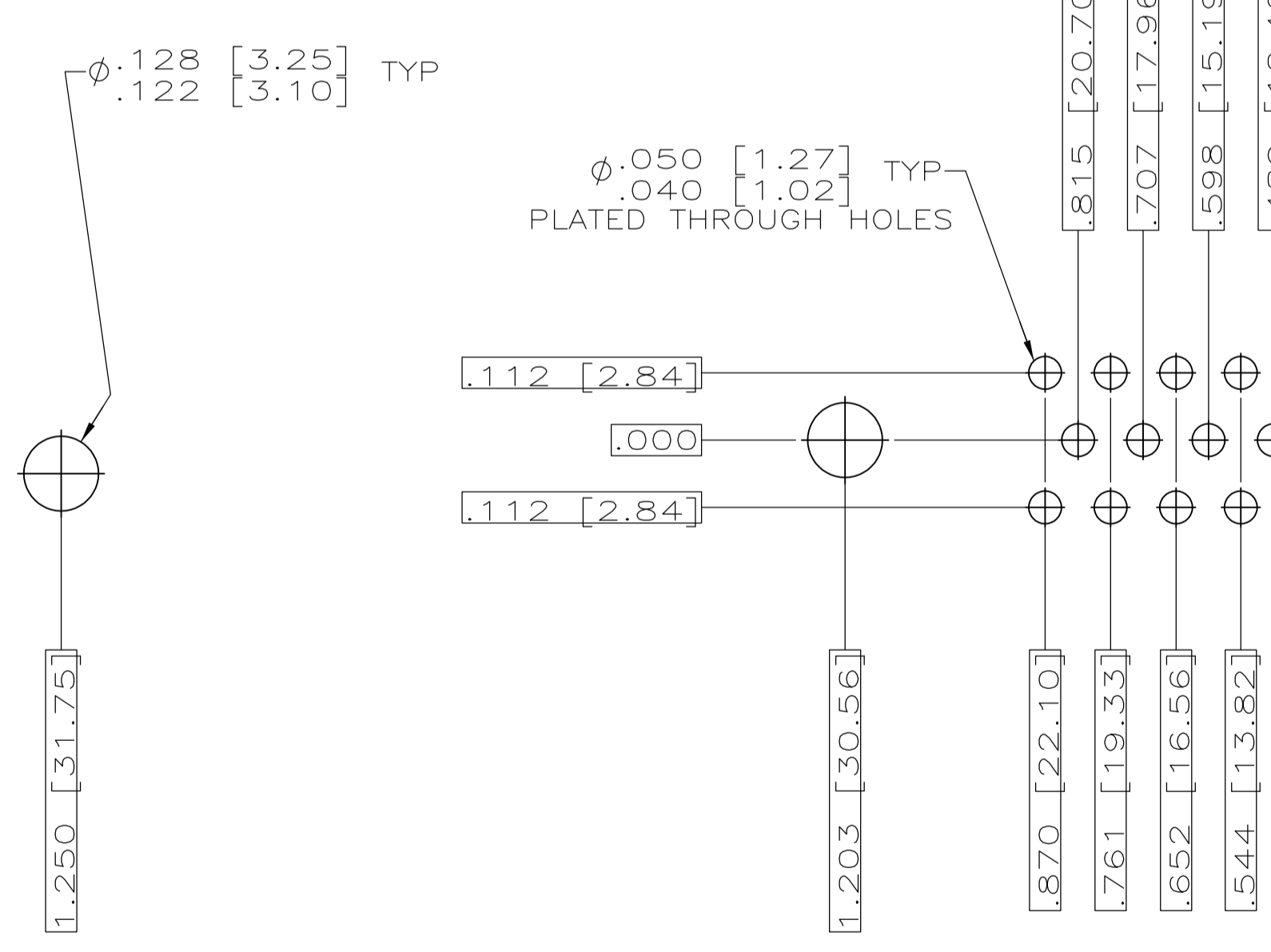

RECOMMENDED P.C. BOARD LAYOUT
SHELL SIZE 5 (50 POSITION) ▲

THIS DRAWING IS A CONTROLLED DOCUMENT.		DWG J.A.Baker	DATE 05MAY97														
DIMENSIONS: INCHES		CHK G. OVER	DATE 15MAY98														
TOLERANCES UNLESS OTHERWISE SPECIFIED:		NAME															
<table border="1"> <tr><td>0 PL</td><td>±</td></tr> <tr><td>1 PL</td><td>±</td></tr> <tr><td>2 PL</td><td>±</td></tr> <tr><td>3 PL</td><td>±</td></tr> <tr><td>4 PL</td><td>±</td></tr> <tr><td>AVG</td><td>±</td></tr> <tr><td>FINISH</td><td>±</td></tr> </table>		0 PL	±	1 PL	±	2 PL	±	3 PL	±	4 PL	±	AVG	±	FINISH	±	PRODUCT SPEC MIL-C-24308	
0 PL	±																
1 PL	±																
2 PL	±																
3 PL	±																
4 PL	±																
AVG	±																
FINISH	±																
MATERIAL SEE CALLOUTS		APPLICATION SPEC															
SEE CALLOUTS		SIZE CAGE CODE DRAWING NO RESTRICTED TO A1 00779 C-443976															
CUSTOMER DRAWING		SCALE 4:1 SHEET 2 OF 2 REV D1															

X-ON Electronics

Largest Supplier of Electrical and Electronic Components

Click to view similar products for [D-Sub MIL Spec Connectors](#) category:

Click to view products by [TE Connectivity](#) manufacturer:

Other Similar products are found below :

[M85049/50-5F](#) [D38999/24WG11PB-LC](#) [MDM-9SH006A](#) [1218697-4](#) [D38999/26WJ61PC L/C](#) [1484349-1](#) [17D25HV](#) [1996840-1](#) [243082-15](#)
[1757682-1](#) [17D-E51218-1](#) [17SDA15S](#) [1883533-1](#) [1883886-1](#) [1883889-1](#) [192900-0377](#) [M24308/8-347](#) [M83513/03-E09C](#) [443961-3](#) [5-](#)
[1218949-1](#) [550-031NF1R6K](#) [3-1236089-2](#) [550E001NF1R3J0L](#) [550T001NF1R6K0L](#) [557T283NF5B08](#) [DC121073157](#) [443869-3](#) [443869-4](#)
[443869-5](#) [550S004NF1R1B0F03](#) [557E283NF1A06](#) [527-019NF0303R2K1F](#) [5-446405-1](#) [550-031NF1R2E](#) [550E003M2R9J0F04](#)
[550E003M3R9J0F05](#) [550E024M104R9J0](#) [550E024NF102R3J0B](#) [550E039NF1R3J1-02](#) [550S003M3R9B0F05](#) [550S004M4R7M0F04](#)
[550S004NF1R1B1F02](#) [550S008M3F0K0F04](#) [550S086M5R3J0L](#) [550S100NF3F0E](#) [550T001M2R7E0L](#) [550T001NF1F0B1L](#)
[550T001NF1R1K0G](#) [550T001NF1R3K0G](#) [550T001NF1R4K0L](#)