

| LOC | DIST | REV | DESCRIPTION | DATE | BY | APPV |
|-----|------|-----|---------------------------|-----------|-----|------|
| DF | AO | B | REVISED PER ECO-13-002054 | 05FEB2013 | MGM | CT |

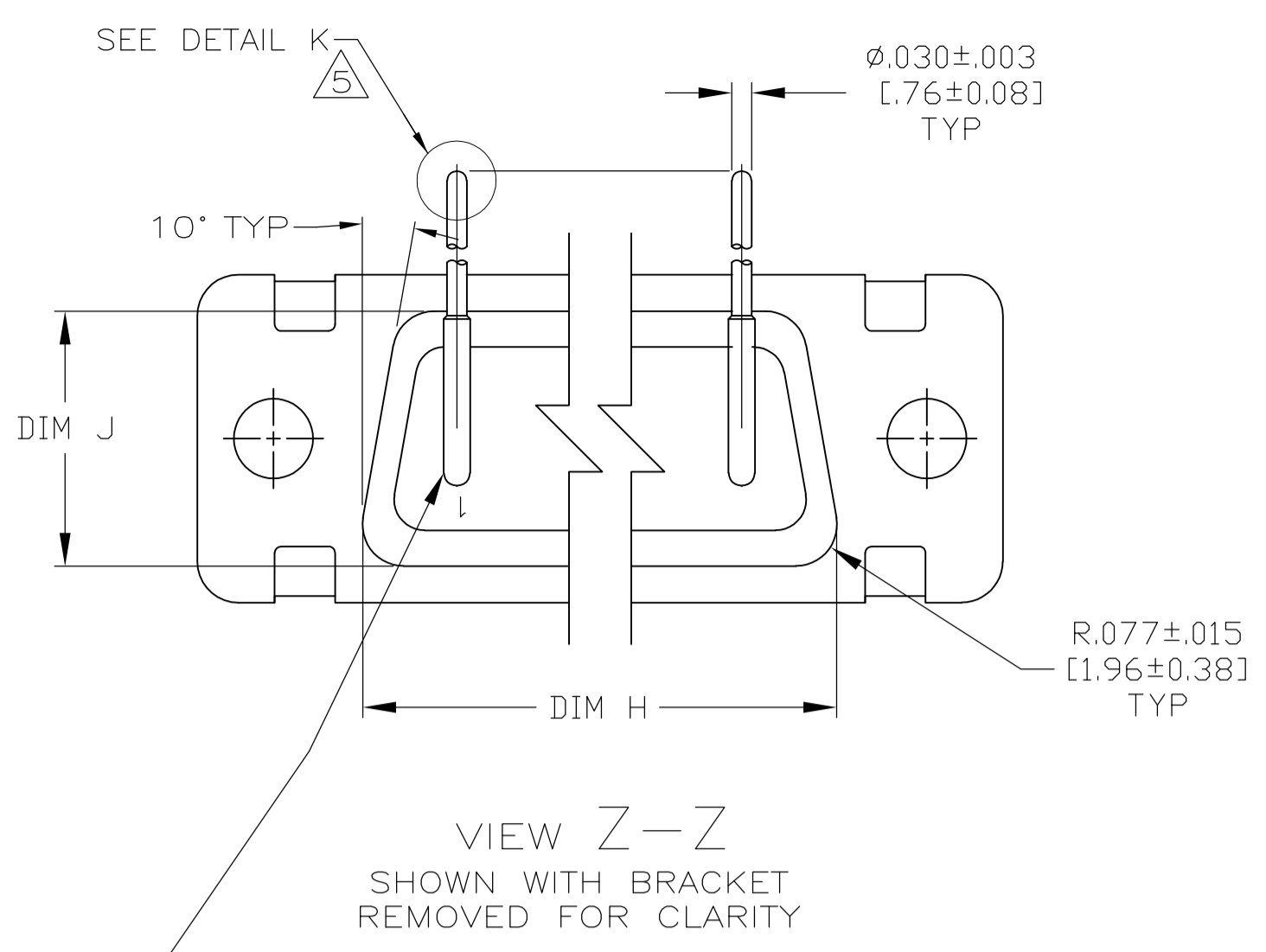
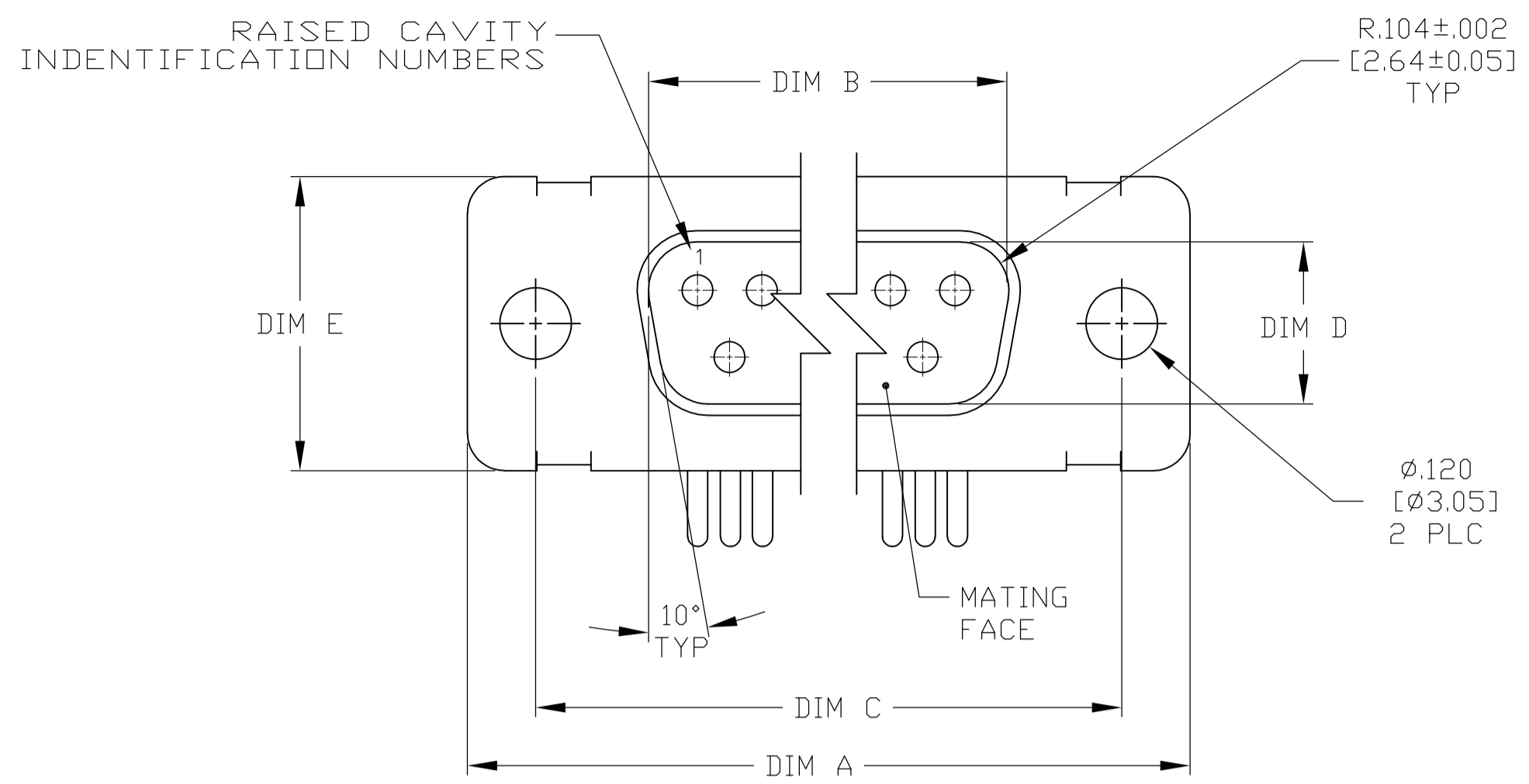

VIEW Z-Z
SHOWN WITH BRACKET REMOVED FOR CLARITY

CONTACT (QTY = NO. OF POSN)
MATL: BRASS PER ASTM-B-16, OR BERYLLIUM COPPER PER ASTM-B-194
FINISH: GOLD PER ASTM-B-488, TYPE II, GRADE C, CLASS 1.27 IN CONTACT MATING AREA, .000010 [0.0003] MIN THK GOLD PER ASTM-B-488 OVER .000050 [0.0013] MIN THK NICKEL PER SAE-AMS-QQ-N-290 ON CONTACT BODY

- SEE SHEET 2 FOR RECOMMENDED P.C. BOARD LAYOUT. TRUE POSITION TOLERANCE FOR P.C. BOARD LAYOUT IS .010 [0.25] AT MAX MATERIAL CONDITION. SUGGESTED BOARD THICKNESS IS .062 [1.57]
- THE CONNECTORS DESCRIBED IN THIS DOCUMENT MEET THE REQUIREMENTS OF MIL-C-24308 AND MATE WITH ANY RECEPTACLE CONNECTOR WITH SAME INSERT ARRANGEMENT.
- MARKED WITH .047 [1.19]-.062 [1.57] HIGH CHARACTERS. FAR SIDE REFERS TO THE WIDE SIDE OF THE KEYSTONE. NEAR SIDE REFERS TO THE NARROW SIDE OF THE KEYSTONE. IF THE SHELL IS TOO SMALL FOR THE ENTIRE MARKING MARKING SHALL BE SPLIT AS FOLLOWS:
A. "M24308" ON FRONT SHELL, FAR SIDE.
B. SLASH SHEET AND DASH NUMBER ON REAR SHELL, FAR SIDE.
C. "MFG'S" (NAME, BRAND OR LOGO), AND DATE CODE ON FRONT SHELL, NEAR SIDE.
D. MFG'S PART NUMBER ON REAR SHELL, NEAR SIDE.
- REQUIREMENT FOR FULL PIN DIAMETER EXTENSION:
.159 [4.04] MIN, SHELL SIZES 1 AND 2.
.150 [3.81] MIN, SHELL SIZES 3 AND 4.
- SOLDER DIPPED PER J-STD-001 WITH Sn63 SOLDER PER J-STD-006 IN THE ENTIRE AREA OF DIMENSION SHOWN. (1757835-6 THRU -10 ONLY.)
- MEETS SOLDERABILITY PER MIL-STD-202 METHOD 208.

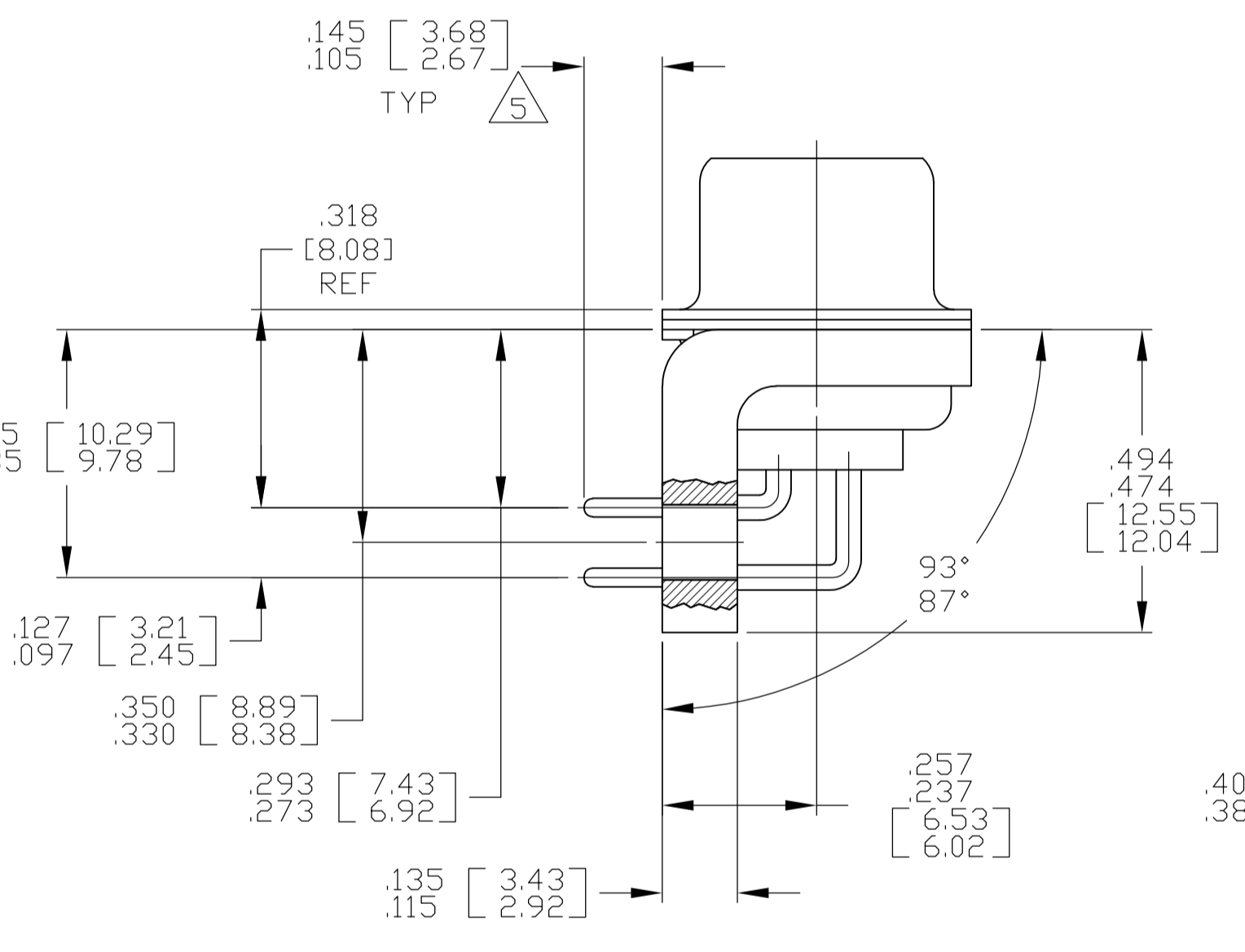
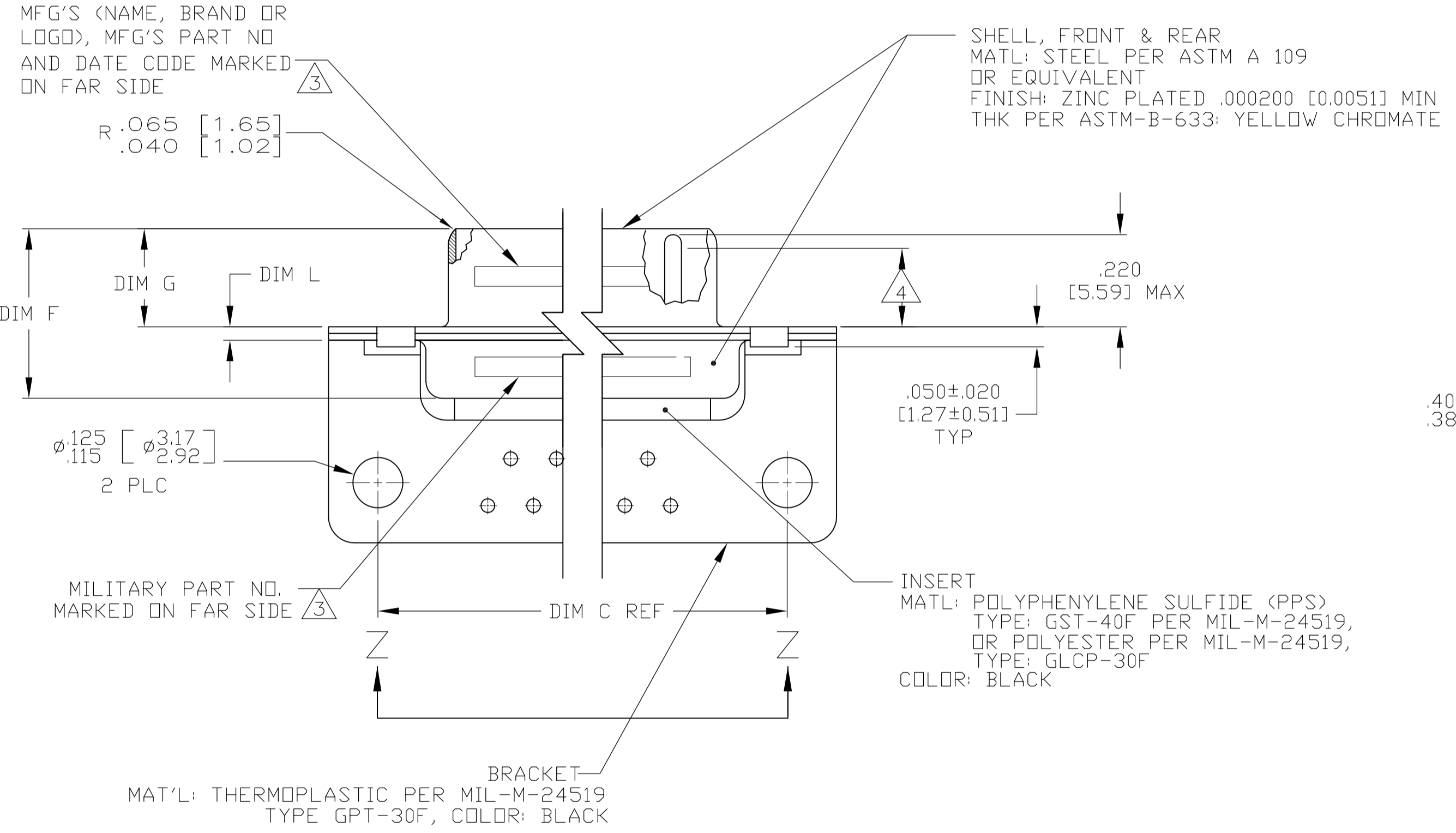

SHELL SIZES 1 THRU 4 CONTACT CONFIGURATION

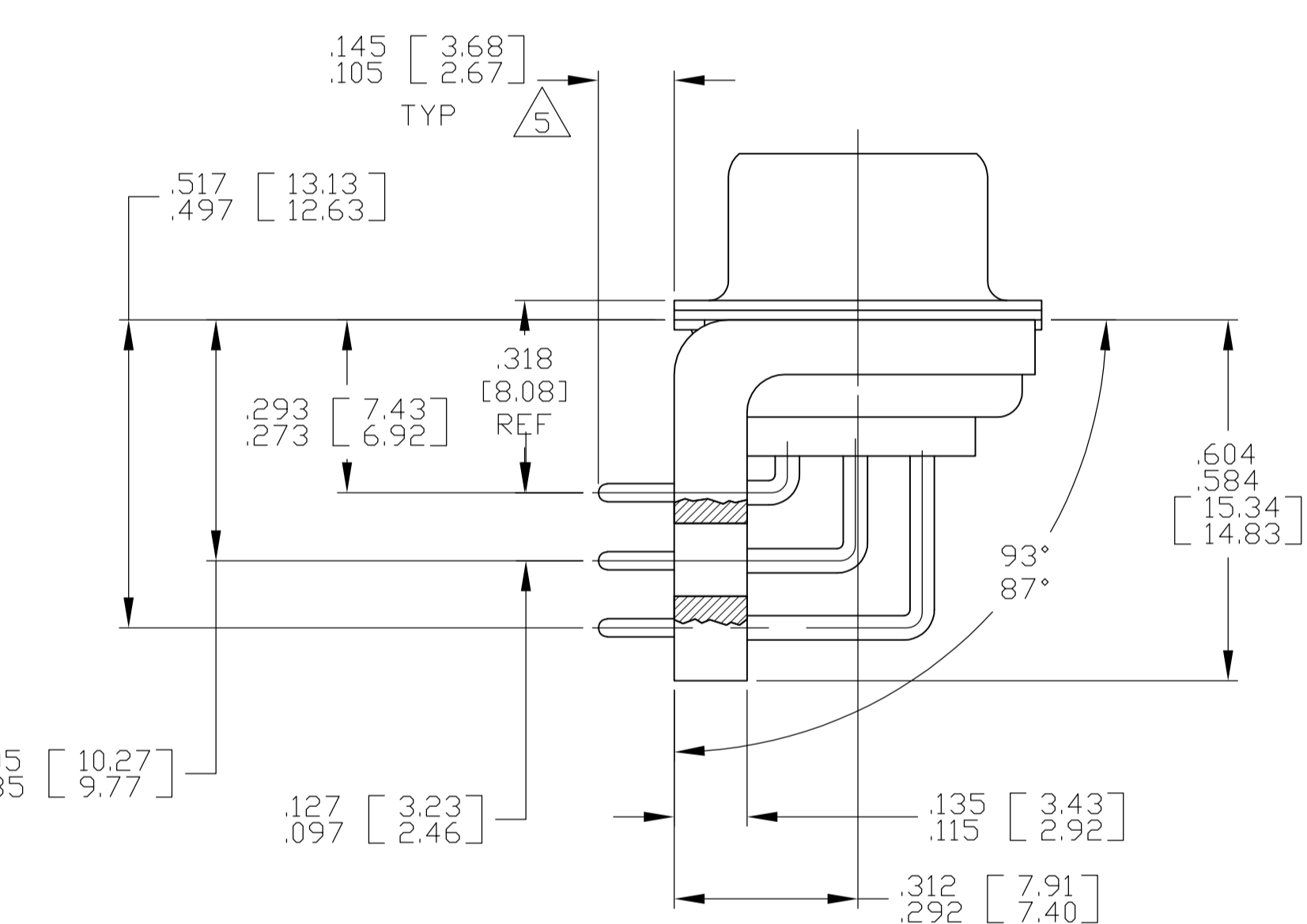

SHELL SIZE 5 CONTACT CONFIGURATION

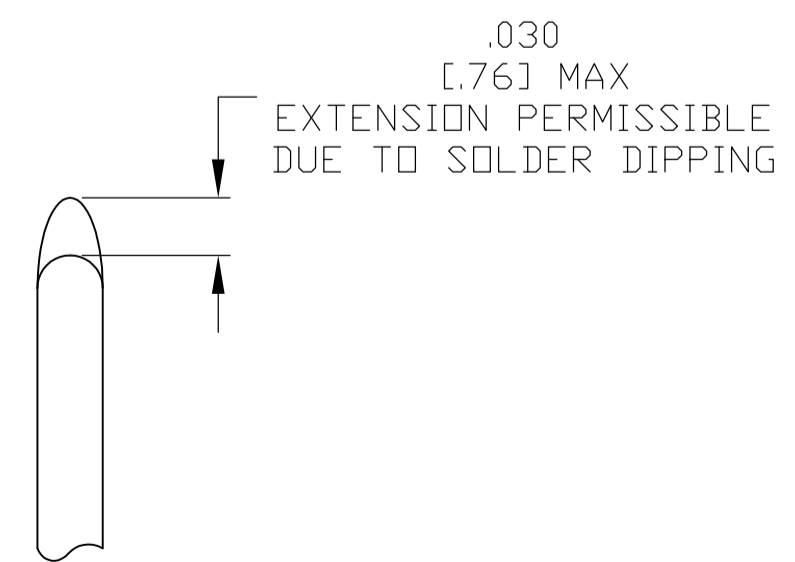

DETAIL K SCALE 10:1 FOR 1757835-6 THRU -10 ONLY

| | | | | | | | | | | | | | | | | | | | |
|------|--------|------|---------|-------|---------|------|--------|------|---------|------|---------|------|---------|-------|---------|-------|---------|-------|---------|
| .049 | [1.24] | .544 | [13.82] | 2.188 | [55.58] | .236 | [5.99] | .436 | [11.07] | .620 | [15.75] | .446 | [11.33] | 2.411 | [61.24] | 2.084 | [52.55] | 2.650 | [67.31] |
| .029 | [0.74] | .524 | [13.31] | 2.168 | [55.07] | .224 | [5.69] | .416 | [10.57] | .590 | [14.99] | .436 | [11.07] | 2.401 | [60.99] | 2.074 | [52.30] | 2.620 | [66.55] |
| .049 | [1.24] | .432 | [10.97] | 2.282 | [57.96] | .236 | [5.99] | .436 | [11.07] | .509 | [12.93] | .334 | [8.48] | 2.505 | [63.63] | 2.187 | [54.97] | 2.744 | [69.70] |
| .029 | [0.74] | .412 | [10.46] | 2.262 | [57.45] | .224 | [5.69] | .416 | [10.57] | .479 | [12.17] | .324 | [8.23] | 2.495 | [63.37] | 2.177 | [54.71] | 2.714 | [68.94] |
| .049 | [1.24] | .432 | [10.97] | 1.635 | [41.53] | .236 | [5.99] | .436 | [11.07] | .509 | [12.93] | .334 | [8.48] | 1.857 | [47.17] | 1.539 | [38.51] | 2.103 | [53.42] |
| .029 | [0.74] | .412 | [10.46] | 1.615 | [41.02] | .224 | [5.69] | .416 | [10.57] | .479 | [12.17] | .324 | [8.23] | 1.847 | [46.91] | 1.529 | [38.25] | 2.073 | [52.65] |
| .040 | [1.02] | .432 | [10.97] | 1.093 | [27.76] | .238 | [6.05] | .432 | [10.97] | .509 | [12.93] | .334 | [8.48] | 1.317 | [33.45] | .999 | [24.79] | 1.556 | [39.52] |
| .020 | [0.51] | .412 | [10.46] | 1.073 | [27.25] | .229 | [5.82] | .412 | [10.46] | .479 | [12.17] | .324 | [8.23] | 1.307 | [33.20] | .989 | [24.54] | 1.526 | [38.76] |
| .049 | [1.24] | .432 | [10.97] | .769 | [19.53] | .238 | [6.05] | .432 | [10.97] | .509 | [12.93] | .334 | [8.48] | .989 | [25.12] | .671 | [16.46] | 1.228 | [31.19] |
| .029 | [0.74] | .412 | [10.46] | .749 | [19.02] | .229 | [5.82] | .412 | [10.46] | .479 | [12.17] | .324 | [8.23] | .979 | [24.87] | .661 | [16.21] | 1.198 | [30.43] |
| .049 | [1.24] | .544 | [13.82] | 2.188 | [55.58] | .236 | [5.99] | .436 | [11.07] | .620 | [15.75] | .446 | [11.33] | 2.411 | [61.24] | 2.084 | [52.55] | 2.650 | [67.31] |
| .029 | [0.74] | .524 | [13.31] | 2.168 | [55.07] | .224 | [5.69] | .416 | [10.57] | .590 | [14.99] | .436 | [11.07] | 2.401 | [60.99] | 2.074 | [52.30] | 2.620 | [66.55] |
| .049 | [1.24] | .432 | [10.97] | 2.282 | [57.96] | .236 | [5.99] | .436 | [11.07] | .509 | [12.93] | .334 | [8.48] | 2.505 | [63.63] | 2.187 | [54.97] | 2.744 | [69.70] |
| .029 | [0.74] | .412 | [10.46] | 2.262 | [57.45] | .224 | [5.69] | .416 | [10.57] | .479 | [12.17] | .324 | [8.23] | 2.495 | [63.37] | 2.177 | [54.71] | 2.714 | [68.94] |
| .049 | [1.24] | .432 | [10.97] | 1.635 | [41.53] | .236 | [5.99] | .436 | [11.07] | .509 | [12.93] | .334 | [8.48] | 1.857 | [47.17] | 1.539 | [38.51] | 2.103 | [53.42] |
| .029 | [0.74] | .412 | [10.46] | 1.615 | [41.02] | .224 | [5.69] | .416 | [10.57] | .479 | [12.17] | .324 | [8.23] | 1.847 | [46.91] | 1.529 | [38.25] | 2.073 | [52.65] |
| .040 | [1.02] | .432 | [10.97] | 1.093 | [27.76] | .238 | [6.05] | .432 | [10.97] | .509 | [12.93] | .334 | [8.48] | 1.317 | [33.45] | .999 | [24.79] | 1.556 | [39.52] |
| .020 | [0.51] | .412 | [10.46] | 1.073 | [27.25] | .229 | [5.82] | .412 | [10.46] | .479 | [12.17] | .324 | [8.23] | 1.307 | [33.20] | .989 | [24.54] | 1.526 | [38.76] |
| .049 | [1.24] | .432 | [10.97] | .769 | [19.53] | .238 | [6.05] | .432 | [10.97] | .509 | [12.93] | .334 | [8.48] | .989 | [25.12] | .671 | [16.46] | 1.228 | [31.19] |
| .029 | [0.74] | .412 | [10.46] | .749 | [19.02] | .229 | [5.82] | .412 | [10.46] | .479 | [12.17] | .324 | [8.23] | .979 | [24.87] | .661 | [16.21] | 1.198 | [30.43] |

| DIM L | DIM J | DIM H | DIM G | DIM F | DIM E | DIM D | DIM C | DIM B | DIM A | INSERT ARRANGEMENT | NO OF POS | SHELL SIZE | MILITARY P/N ON CONNECTOR | MFG'S P/N MARKED ON CONNECTOR | MFG'S PART NO. | | | | | | | | | | |
|-------|--------|-------|---------|-------|---------|-------|--------|-------|---------|--------------------|-----------|------------|---------------------------|-------------------------------|----------------|-------|---------|-------|---------|-----------|----|---|---------------|-----------|-------------|
| .049 | [1.24] | .544 | [13.82] | 2.188 | [55.58] | .236 | [5.99] | .436 | [11.07] | .620 | [15.75] | .446 | [11.33] | 2.411 | [61.24] | 2.084 | [52.55] | 2.650 | [67.31] | MS18277-1 | 50 | 5 | M24308/24-29Z | 1757835-5 | 1-1757835-0 |
| .029 | [0.74] | .524 | [13.31] | 2.168 | [55.07] | .224 | [5.69] | .416 | [10.57] | .590 | [14.99] | .436 | [11.07] | 2.401 | [60.99] | 2.074 | [52.30] | 2.620 | [66.55] | MS18276-1 | 37 | 4 | M24308/24-28Z | 1757835-4 | 1757835-9 |
| .049 | [1.24] | .432 | [10.97] | 2.282 | [57.96] | .236 | [5.99] | .436 | [11.07] | .509 | [12.93] | .334 | [8.48] | 2.505 | [63.63] | 2.187 | [54.97] | 2.744 | [69.70] | MS18275-1 | 25 | 3 | M24308/24-27Z | 1757835-3 | 1757835-8 |
| .029 | [0.74] | .412 | [10.46] | 2.262 | [57.45] | .224 | [5.69] | .416 | [10.57] | .479 | [12.17] | .324 | [8.23] | 2.495 | [63.37] | 2.177 | [54.71] | 2.714 | [68.94] | MS18274-1 | 15 | 2 | M24308/24-26Z | 1757835-2 | 1757835-7 |
| .040 | [1.02] | .432 | [10.97] | 1.093 | [27.76] | .238 | [6.05] | .432 | [10.97] | .509 | [12.93] | .334 | [8.48] | 1.317 | [33.45] | .999 | [24.79] | 1.556 | [39.52] | MS18273-1 | 9 | 1 | M24308/24-25Z | 1757835-1 | 1757835-6 |
| .020 | [0.51] | .412 | [10.46] | 1.073 | [27.25] | .229 | [5.82] | .412 | [10.46] | .479 | [12.17] | .324 | [8.23] | 1.307 | [33.20] | .989 | [24.54] | 1.526 | [38.76] | MS18272-1 | 9 | 1 | M24308/24-25Z | 1757835-1 | 1757835-5 |

THIS DRAWING IS A CONTROLLED DOCUMENT.

DMN: C.C. THOMAS 10FEB2008
CHK: D. MILLER 2-13-06
APPV: D. MILLER 2-13-06

TE Connectivity

PLUG ASSEMBLY, AMP/LMITE, RT ANGLE, SERIES 109, SIZE 1 THRU 5

APPLIC. SPEC: 1757835

SCALE: 4:1 SHEET 1 OF 2 REV B

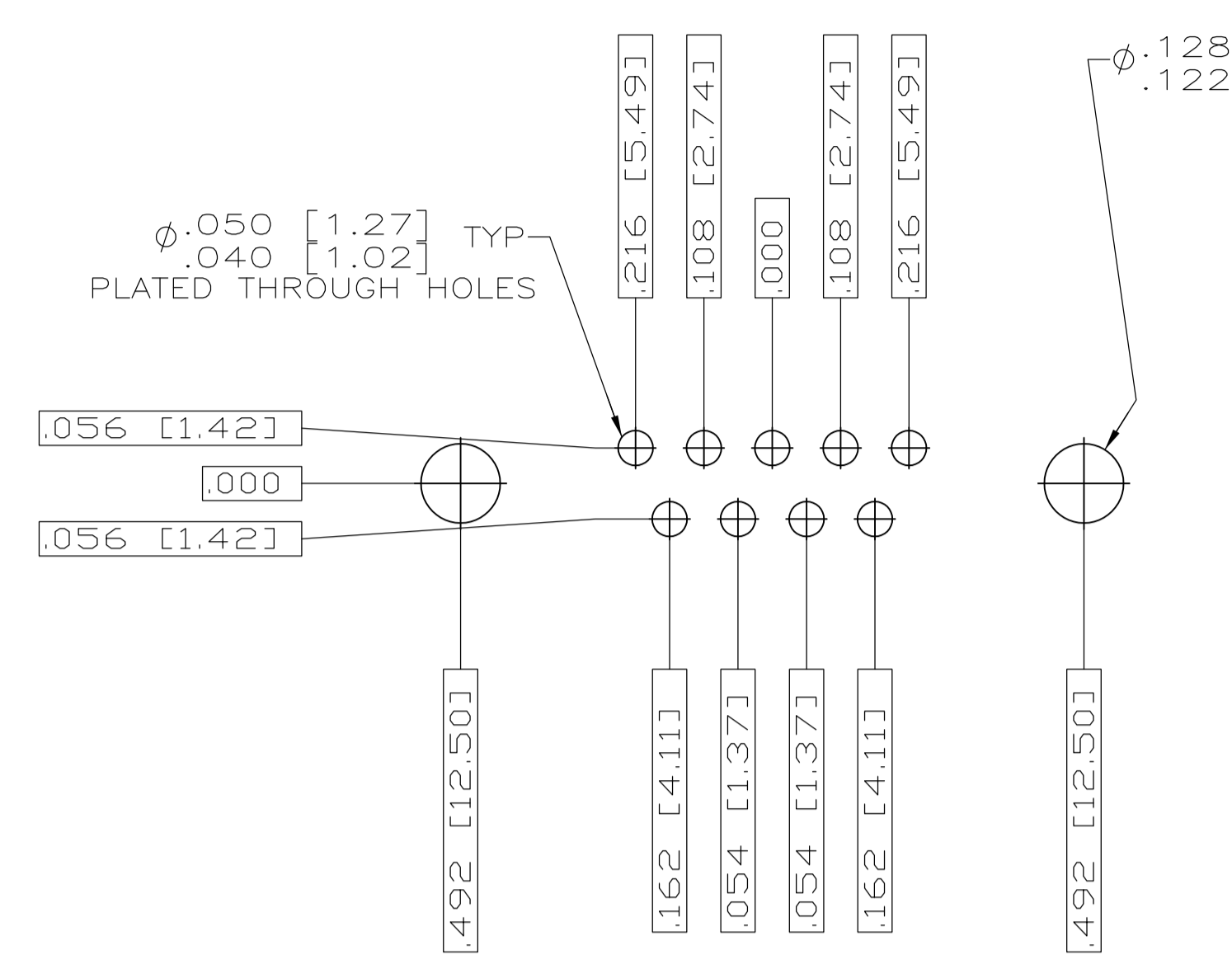

RECOMMENDED P.C. BOARD LAYOUT
SHELL SIZE 1 (9 POSITION) ⚠

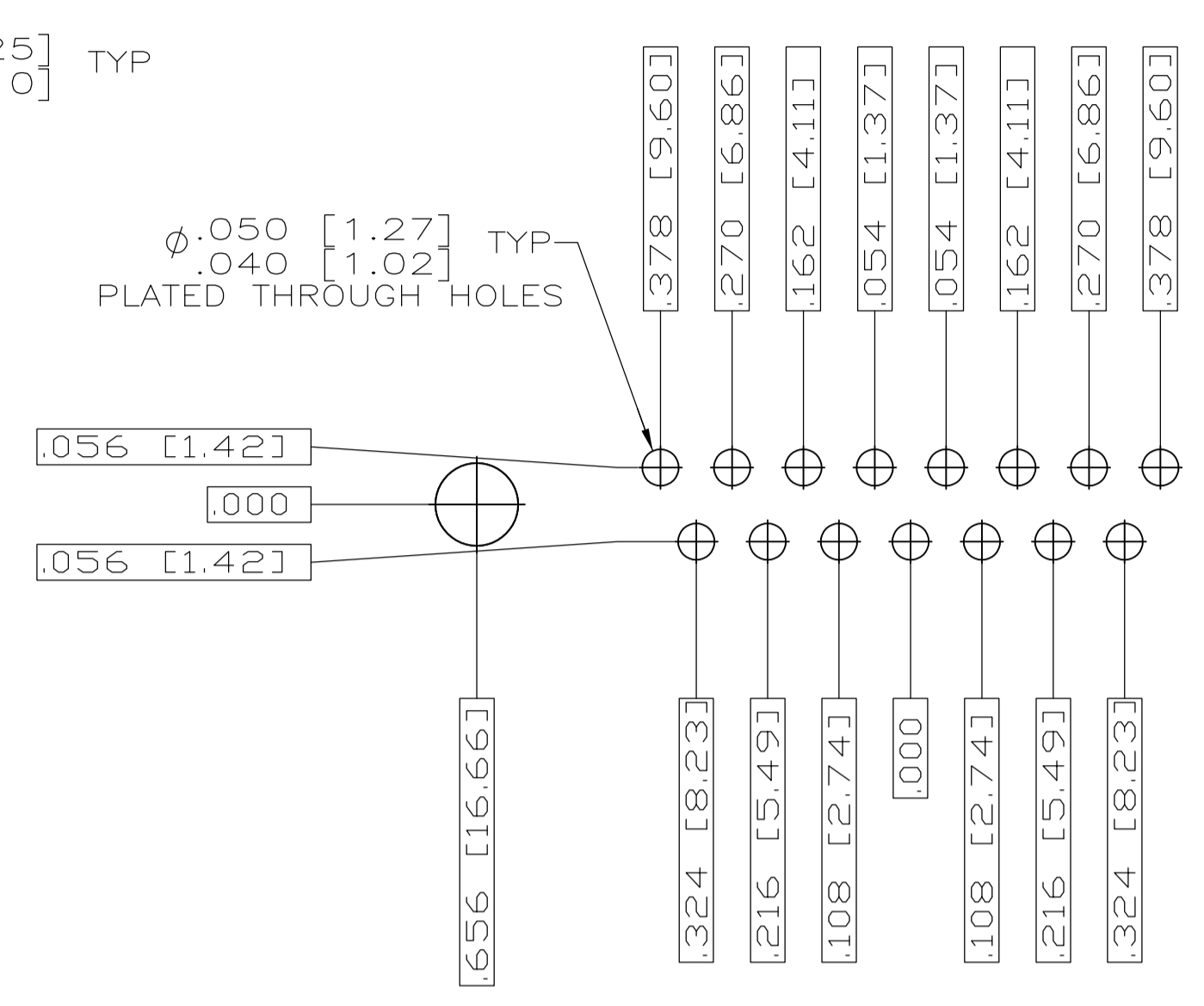

RECOMMENDED P.C. BOARD LAYOUT
SHELL SIZE 2 (15 POSITION) ⚠

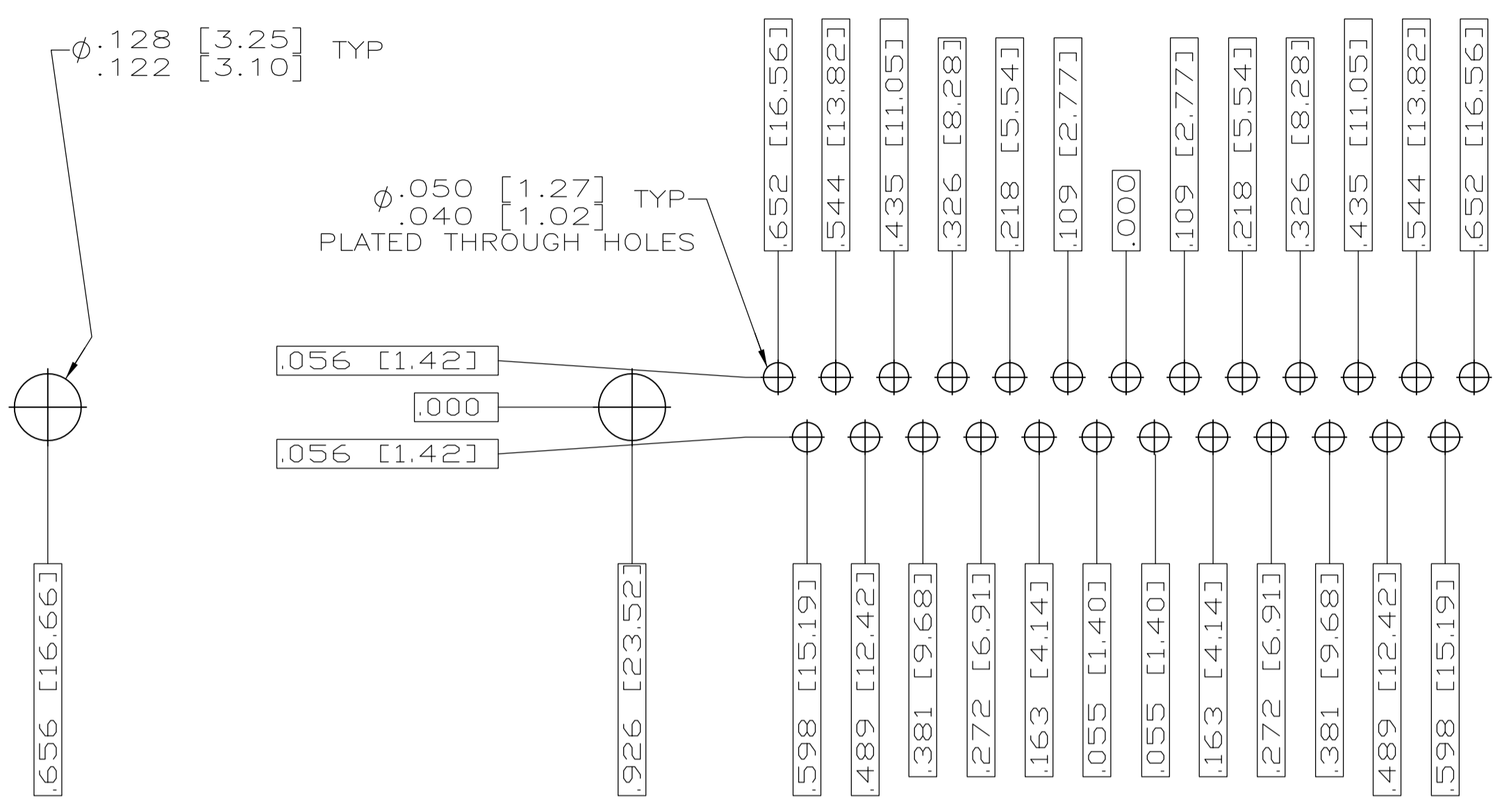

RECOMMENDED P.C. BOARD LAYOUT
SHELL SIZE 3 (25 POSITION) ⚠

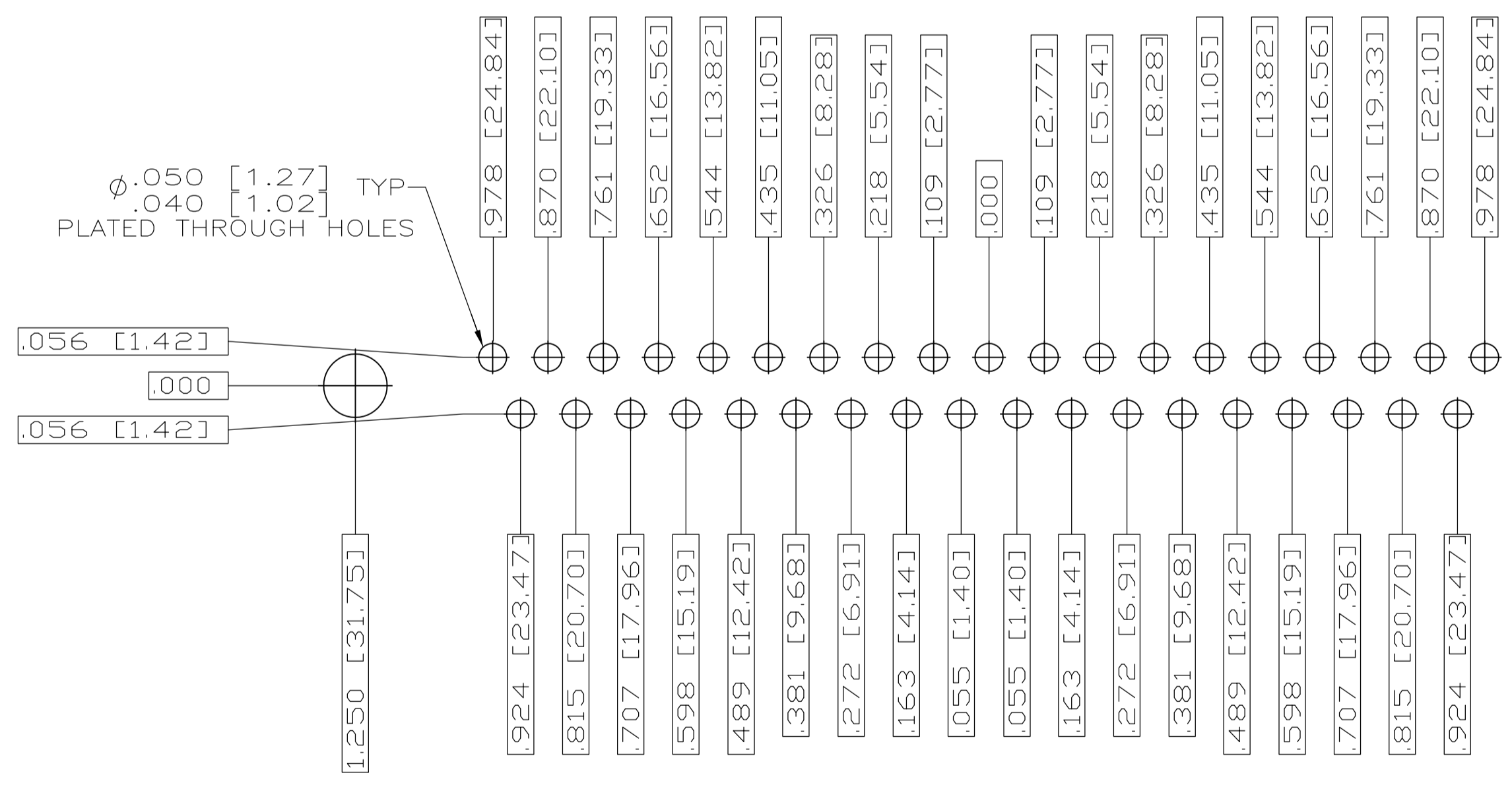

RECOMMENDED P.C. BOARD LAYOUT
SHELL SIZE 4 (37 POSITION) ⚠



RECOMMENDED P.C. BOARD LAYOUT
SHELL SIZE 5 (50 POSITION) ⚠

| | | | | |
|--|--|--|---|--|
| THIS DRAWING IS A CONTROLLED DOCUMENT. | | DWN C.C. THOMAS 2-10-06 CHK D. HOFFMAN 2-13-06 APVO D. MILLER 2-13-06 | TE Connectivity | |
| DIMENSIONS: INCHES TOLERANCES UNLESS OTHERWISE SPECIFIED: 0 PL ± .005 1 PL ± .005 2 PL ± .005 3 PL ± .005 4 PL ± .005 ANGLES ± .1° | MATERIAL SEE CALLOUTS FINISH SEE CALLOUTS | NAME PLUG ASSY,AMPLIMITE RIGHT ANGLE,SERIES 109,SIZE 1 THRU 5 APPLICATION SPEC SIZE A1 CAGE CODE 00779 DRAWING NO 1757835 WEIGHT RESTRICTED TO CUSTOMER DRAWING | SCALE 4:1 SHEET 2 OF 2 REV B | |

X-ON Electronics

Largest Supplier of Electrical and Electronic Components

Click to view similar products for [D-Sub MIL Spec Connectors](#) category:

Click to view products by [TE Connectivity](#) manufacturer:

Other Similar products are found below :

[M85049/50-5F](#) [D38999/24WG11PB-LC](#) [MDM-9SH006A](#) [1218697-4](#) [D38999/26WJ61PC L/C](#) [1484349-1](#) [17D25HV](#) [1996840-1](#) [243082-15](#)
[1757682-1](#) [17D-E51218-1](#) [17SDA15S](#) [1883533-1](#) [1883886-1](#) [1883889-1](#) [192900-0377](#) [M24308/8-347](#) [M83513/03-E09C](#) [443961-3](#) [5-](#)
[1218949-1](#) [550-031NF1R6K](#) [3-1236089-2](#) [550E001NF1R3J0L](#) [550T001NF1R6K0L](#) [557T283NF5B08](#) [DB121073-56](#) [DC121073157](#)
[443869-3](#) [443869-4](#) [443869-5](#) [550S004NF1R1B0F03](#) [557E283NF1A06](#) [527-019NF0303R2K1F](#) [5-446405-1](#) [550-031NF1R2E](#)
[550E003M2R9J0F04](#) [550E003M3R9J0F05](#) [550E024M104R9J0](#) [550E024NF102R3J0B](#) [550E039NF1R3J1-02](#) [550S003M3R9B0F05](#)
[550S004M4R7M0F04](#) [550S004NF1R1B1F02](#) [550S008M3F0K0F04](#) [550S086M5R3J0L](#) [550S100NF3F0E](#) [550T001M2R7E0L](#)
[550T001NF1F0B1L](#) [550T001NF1R1K0G](#) [550T001NF1R3K0G](#)