

LOC	DIST	REV	DESCRIPTION	DATE	DMN	APVD
DF	AO	B	REVISED PER ECO-13-002054	05FEB2013	MGM	CT

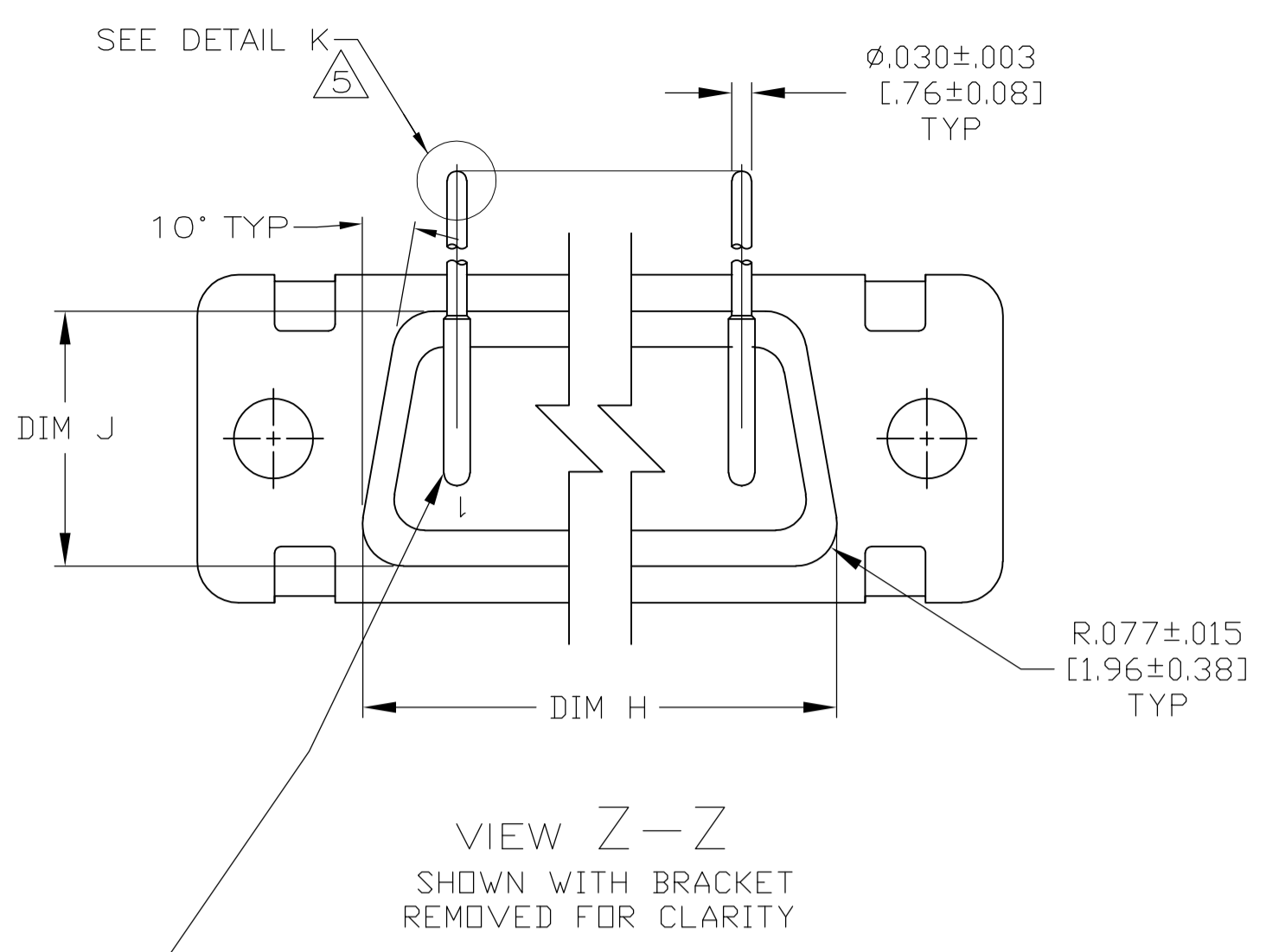

CONTACT (QTY = NO. OF POSN)
 MATL: BRASS PER ASTM-B-16, OR BERYLLIUM COPPER PER ASTM-B-194
 FINISH: GOLD PER ASTM-B-488, TYPE II, GRADE C, CLASS 1.27 IN CONTACT MATING AREA, .000010 [0.0003] MIN THK GOLD PER ASTM-B-488 OVER .000050 [0.0013] MIN THK NICKEL PER SAE-AMS-QQ-N-290 ON CONTACT BODY

1. SEE SHEET 2 FOR RECOMMENDED P.C. BOARD LAYOUT. TRUE POSITION TOLERANCE FOR P.C. BOARD LAYOUT IS .010 [0.25] AT MAX MATERIAL CONDITION. SUGGESTED BOARD THICKNESS IS .062 [1.57]
2. THE CONNECTORS DESCRIBED IN THIS DOCUMENT MEET THE REQUIREMENTS OF MIL-C-24308 AND MATE WITH ANY RECEPTACLE CONNECTOR WITH SAME INSERT ARRANGEMENT.
3. MARKED WITH .047 [1.19]-.062 [1.57] HIGH CHARACTERS. FAR SIDE REFERS TO THE WIDE SIDE OF THE KEYSTONE. NEAR SIDE REFERS TO THE NARROW SIDE OF THE KEYSTONE. IF THE SHELL IS TOO SMALL FOR THE ENTIRE MARKING MARKING SHALL BE SPLIT AS FOLLOWS:
 - A. "M24308" ON FRONT SHELL, FAR SIDE.
 - B. SLASH SHEET AND DASH NUMBER ON REAR SHELL, FAR SIDE.
 - C. "MFG'S" (NAME, BRAND OR LOGO) AND DATE CODE ON FRONT SHELL, NEAR SIDE.
 - D. MFG'S PART NUMBER ON REAR SHELL, NEAR SIDE.
4. REQUIREMENT FOR FULL PIN DIAMETER EXTENSION: .159 [4.04] MIN, SHELL SIZES 1 AND 2; .150 [3.81] MIN, SHELL SIZES 3 AND 4.
5. SOLDER DIPPED PER J-STD-001 WITH Sn63 SOLDER PER J-STD-006 IN THE ENTIRE AREA OF DIMENSION SHOWN. (1757837-6 THRU -10 ONLY.)
6. MEETS SOLDERABILITY PER MIL-STD-202 METHOD 208.

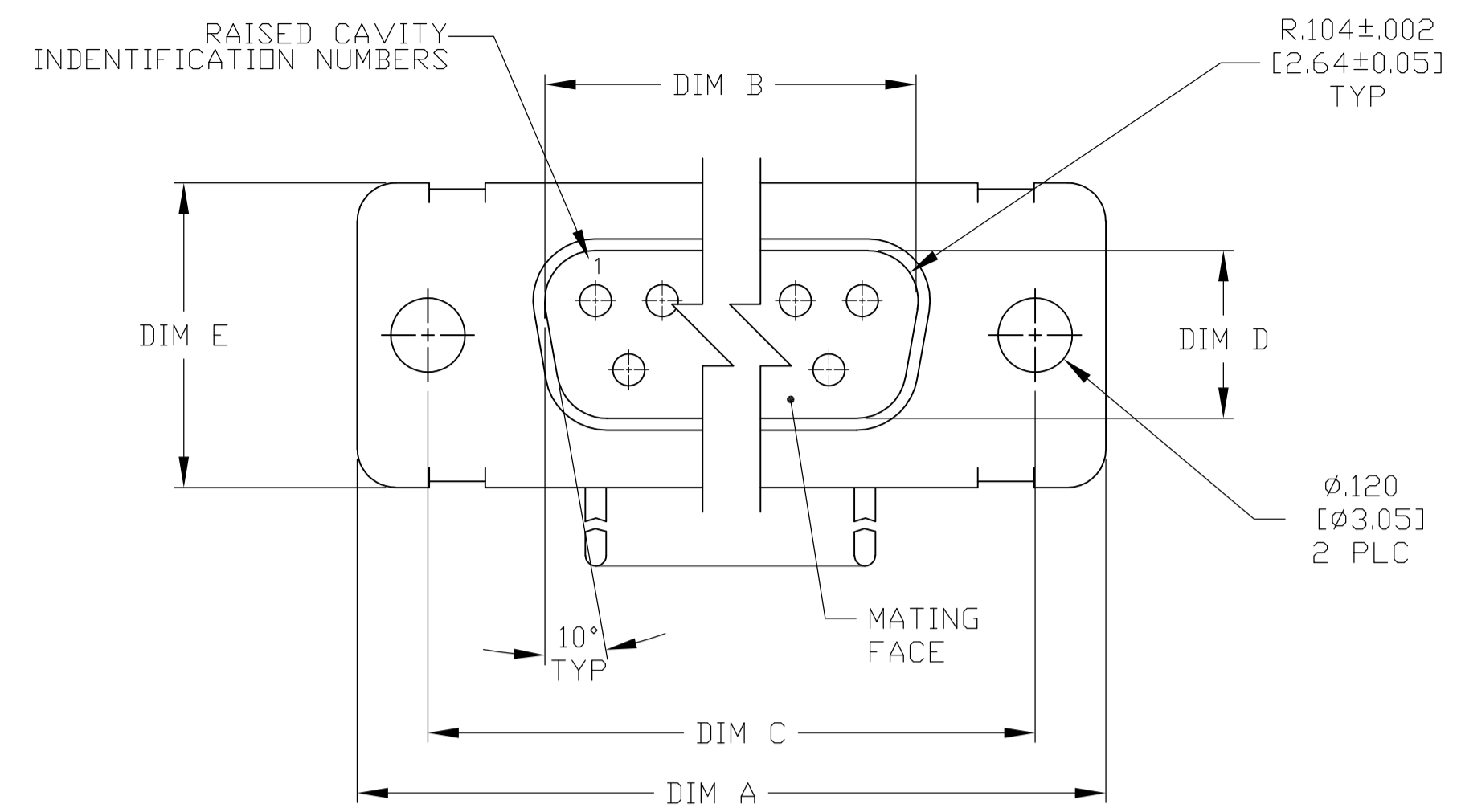
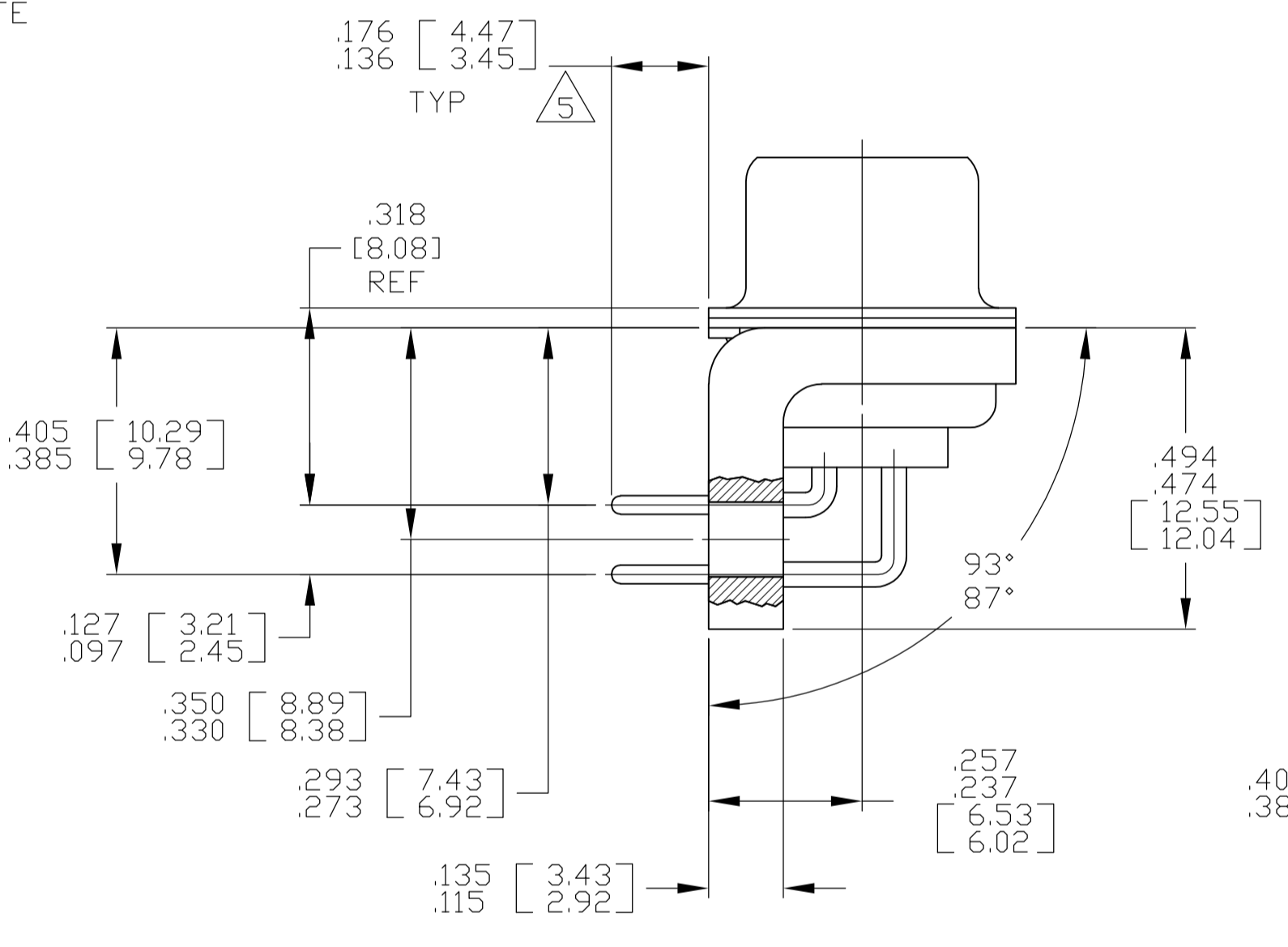
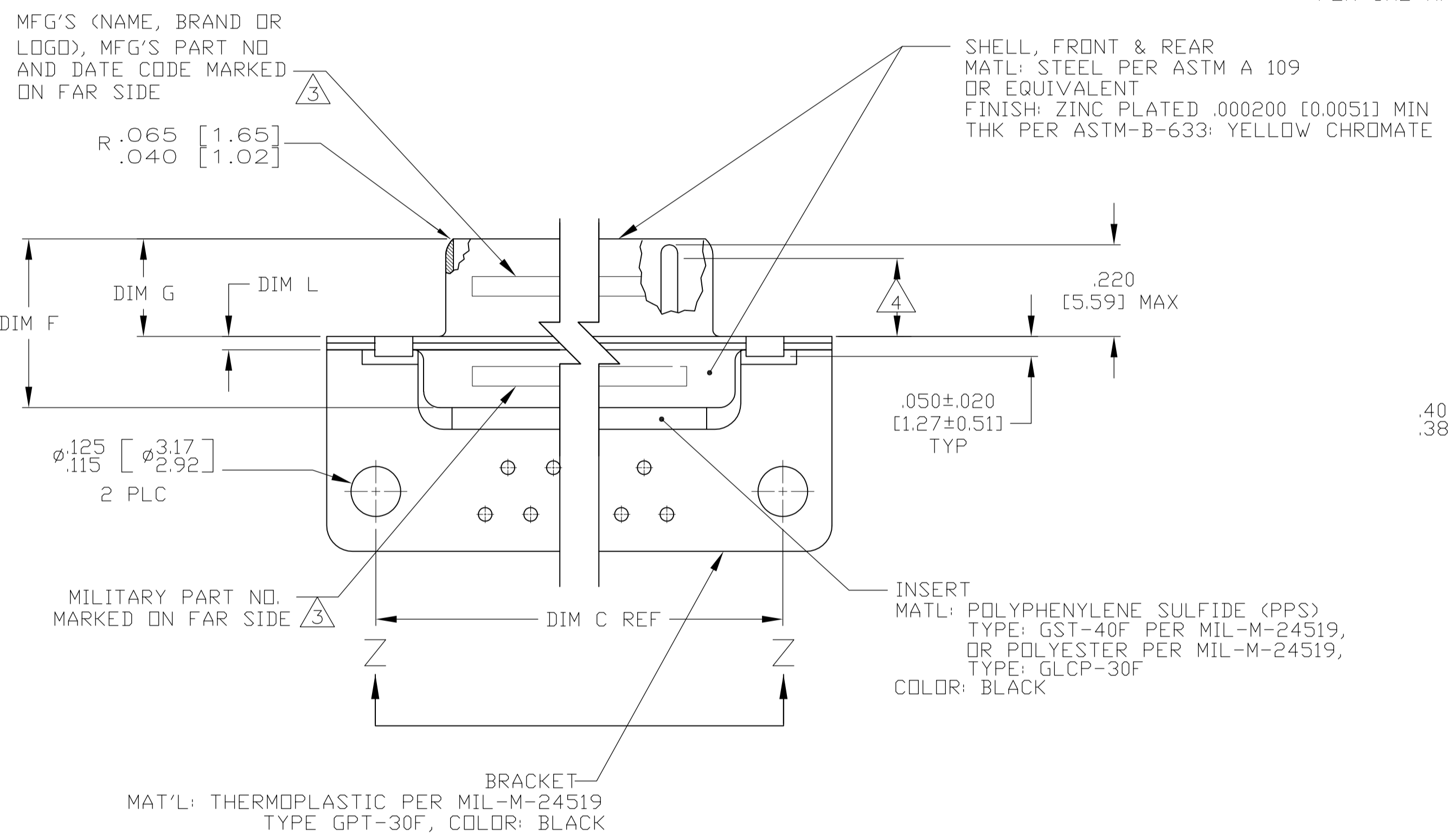

SHELL SIZES 1 THRU 4 CONTACT CONFIGURATION

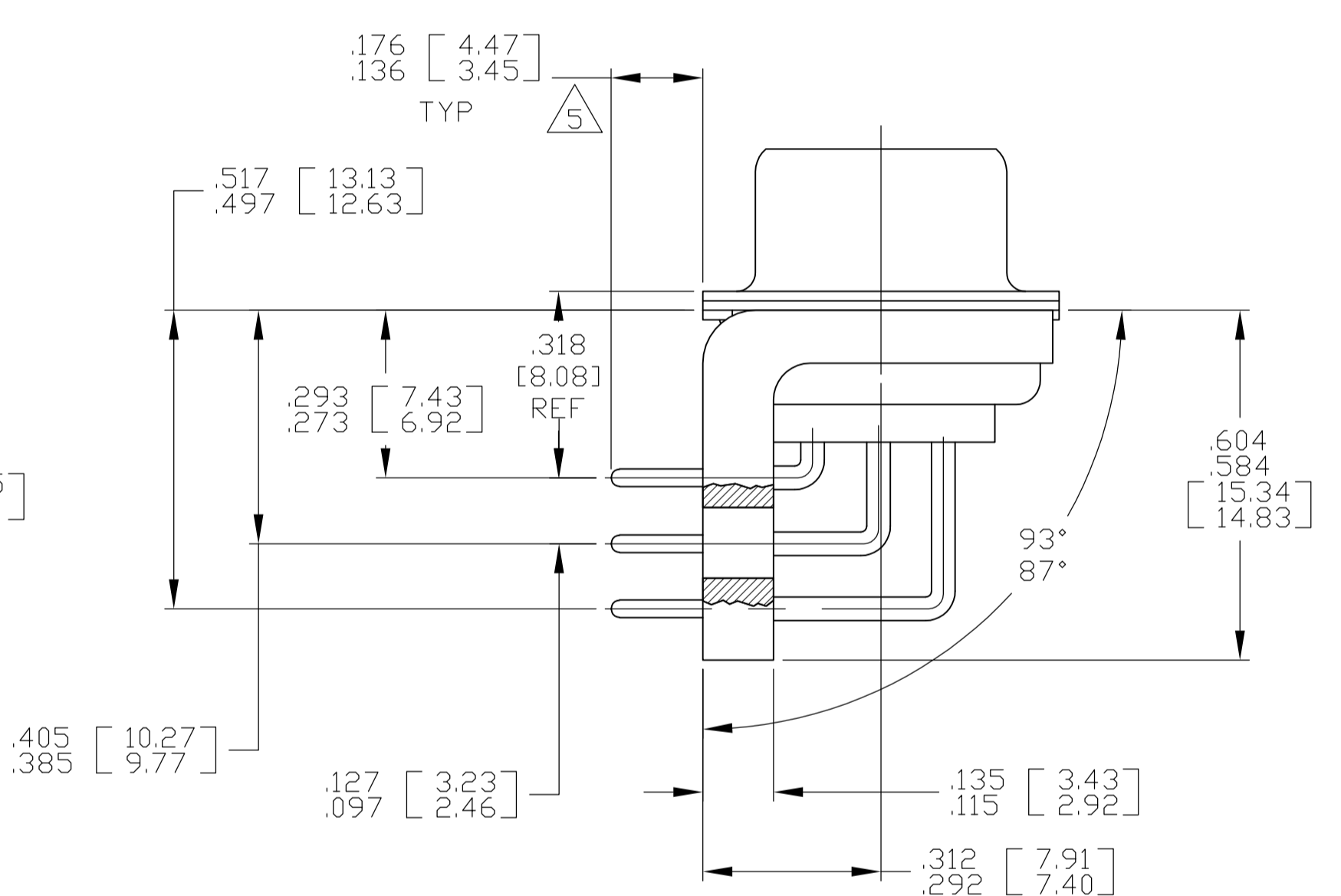

SHELL SIZE 5 CONTACT CONFIGURATION

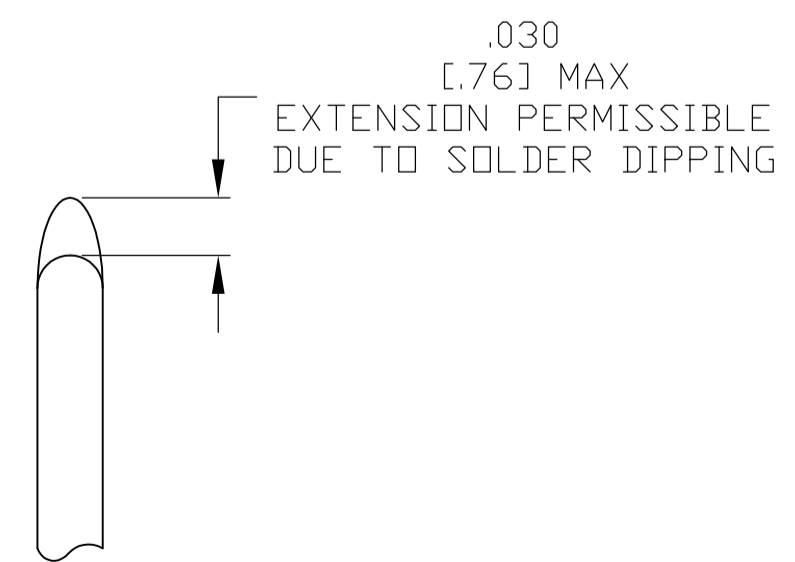

DETAIL K SCALE 10:1 FOR 1757837-6 THRU -10 ONLY

.049	.124	.544	13.82	2.188	55.58	.236	5.99	.436	11.07	.620	15.75	.446	11.33	2.411	61.24	2.084	52.55	2.650	67.31
.029	[0.74]	.524	[13.31]	2.168	[55.07]	.224	[5.69]	.416	[10.57]	.590	[14.99]	.436	[11.07]	2.401	[60.99]	2.074	[52.30]	2.620	[66.55]
.049	.124	.432	10.97	2.282	57.96	.236	5.99	.436	11.07	.509	12.93	.334	8.48	2.505	63.63	2.187	54.97	2.744	69.70
.029	[0.74]	.412	[10.46]	2.262	[57.45]	.224	[5.69]	.416	[10.57]	.479	[12.17]	.324	[8.23]	2.495	[63.37]	2.177	[54.71]	2.714	[68.94]
.049	.124	.432	10.97	1.635	41.53	.236	5.99	.436	11.07	.509	12.93	.334	8.48	1.857	47.17	1.539	38.51	2.103	53.42
.029	[0.74]	.412	[10.46]	1.615	[41.02]	.224	[5.69]	.416	[10.57]	.479	[12.17]	.324	[8.23]	1.847	[46.91]	1.529	[38.25]	2.073	[52.65]
.040	1.02	.432	10.97	1.093	27.76	.238	6.05	.432	10.97	.509	12.93	.334	8.48	1.317	33.45	.999	24.79	1.556	39.52
.020	[0.51]	.412	[10.46]	1.073	[27.25]	.229	[5.82]	.412	[10.46]	.479	[12.17]	.324	[8.23]	1.307	[33.20]	.989	[24.54]	1.526	[38.76]
.040	1.02	.432	10.97	.769	19.53	.238	6.05	.432	10.97	.509	12.93	.334	8.48	.989	25.12	.671	16.46	1.228	31.19
.020	[0.51]	.412	[10.46]	.749	[19.02]	.229	[5.82]	.412	[10.46]	.479	[12.17]	.324	[8.23]	.979	[24.87]	.661	[16.21]	1.198	[30.43]
.049	.124	.544	13.82	2.188	55.58	.236	5.99	.436	11.07	.620	15.75	.446	11.33	2.411	61.24	2.084	52.55	2.650	67.31
.029	[0.74]	.524	[13.31]	2.168	[55.07]	.224	[5.69]	.416	[10.57]	.590	[14.99]	.436	[11.07]	2.401	[60.99]	2.074	[52.30]	2.620	[66.55]
.049	.124	.432	10.97	2.282	57.96	.236	5.99	.436	11.07	.509	12.93	.334	8.48	2.505	63.63	2.187	54.97	2.744	69.70
.029	[0.74]	.412	[10.46]	2.262	[57.45]	.224	[5.69]	.416	[10.57]	.479	[12.17]	.324	[8.23]	2.495	[63.37]	2.177	[54.71]	2.714	[68.94]
.049	.124	.432	10.97	1.635	41.53	.236	5.99	.436	11.07	.509	12.93	.334	8.48	1.857	47.17	1.539	38.51	2.103	53.42
.029	[0.74]	.412	[10.46]	1.615	[41.02]	.224	[5.69]	.416	[10.57]	.479	[12.17]	.324	[8.23]	1.847	[46.91]	1.529	[38.25]	2.073	[52.65]
.040	1.02	.432	10.97	1.093	27.76	.238	6.05	.432	10.97	.509	12.93	.334	8.48	1.317	33.45	.999	24.79	1.556	39.52
.020	[0.51]	.412	[10.46]	1.073	[27.25]	.229	[5.82]	.412	[10.46]	.479	[12.17]	.324	[8.23]	1.307	[33.20]	.989	[24.54]	1.526	[38.76]
.040	1.02	.432	10.97	.769	19.53	.238	6.05	.432	10.97	.509	12.93	.334	8.48	.989	25.12	.671	16.46	1.228	31.19
.020	[0.51]	.412	[10.46]	.749	[19.02]	.229	[5.82]	.412	[10.46]	.479	[12.17]	.324	[8.23]	.979	[24.87]	.661	[16.21]	1.198	[30.43]

DIM L	DIM J	DIM H	DIM G	DIM F	DIM E	DIM D	DIM C	DIM B	DIM A	INSERT ARRANGEMENT	NO OF POS	SHELL SIZE	MILITARY P/N ON CONNECTOR	MFG'S P/N MARKED ON CONNECTOR	MFG'S PART NO.
										3			3		

THIS DRAWING IS A CONTROLLED DOCUMENT.

DIMENSIONS: INCHES	TOLERANCES UNLESS OTHERWISE SPECIFIED:	DMN: C.C. THOMAS 2-23-06	APVD: D. MILLER 2-23-06
0 PLC ± .005	1 PLC ± .005	NAME: D. MILLER	PRODUCT SPEC: PLUG ASSEMBLY, AMPLIMITE, RT ANGLE, SERIES 109, SIZE 1 THRU 5
2 PLC ± .005	3 PLC ± .005	APPLICATION SPEC: A1	SIZE: 4:1
4 PLC ± .005	ANGLES ± .1°	WEIGHT: 1757837	RESTRICTED TO: 1 OF 2

CUSTOMER DRAWING SCALE 4:1 SHEET 1 OF 2 REV B

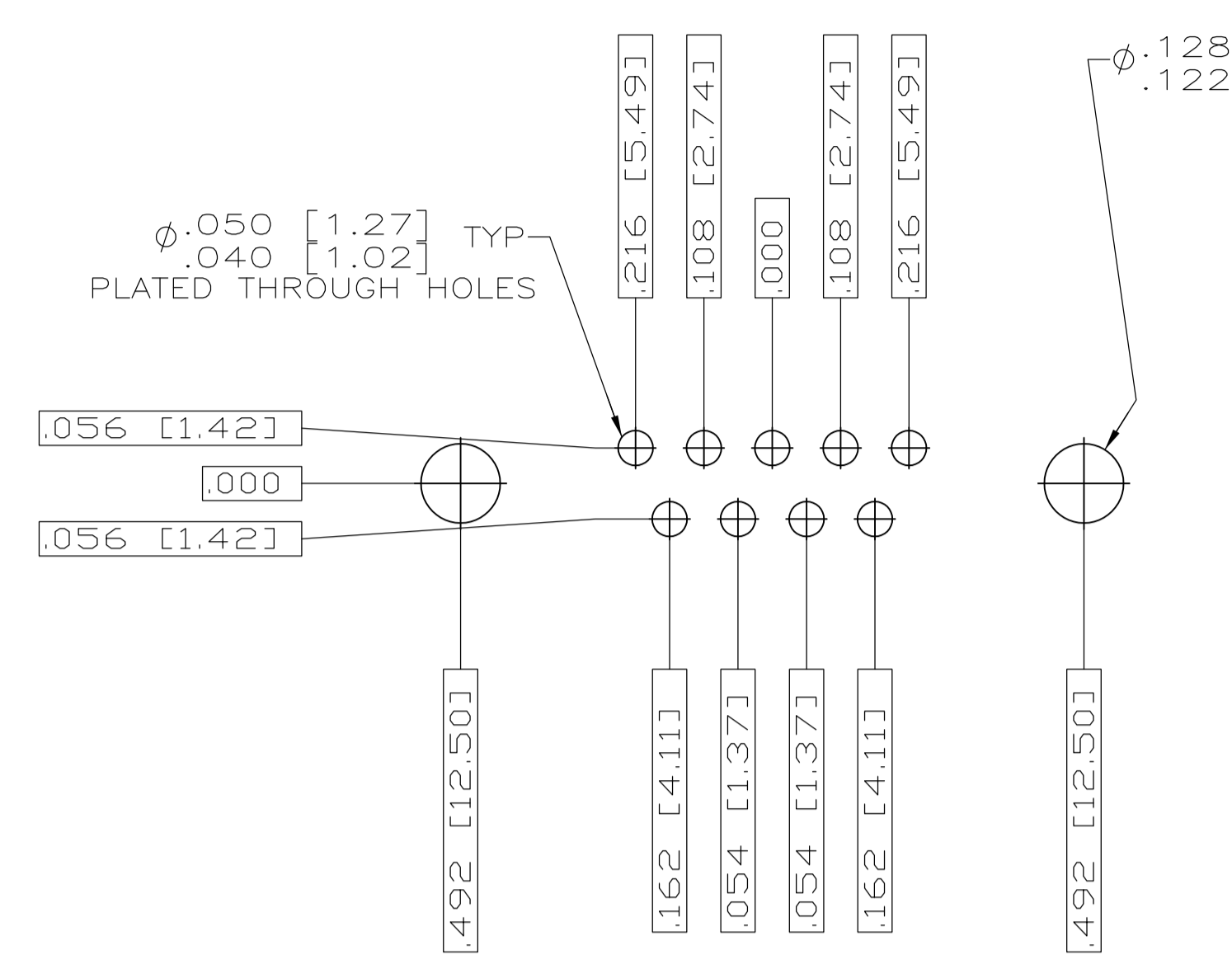

RECOMMENDED P.C. BOARD LAYOUT
 SHELL SIZE 1 (9 POSITION) Δ

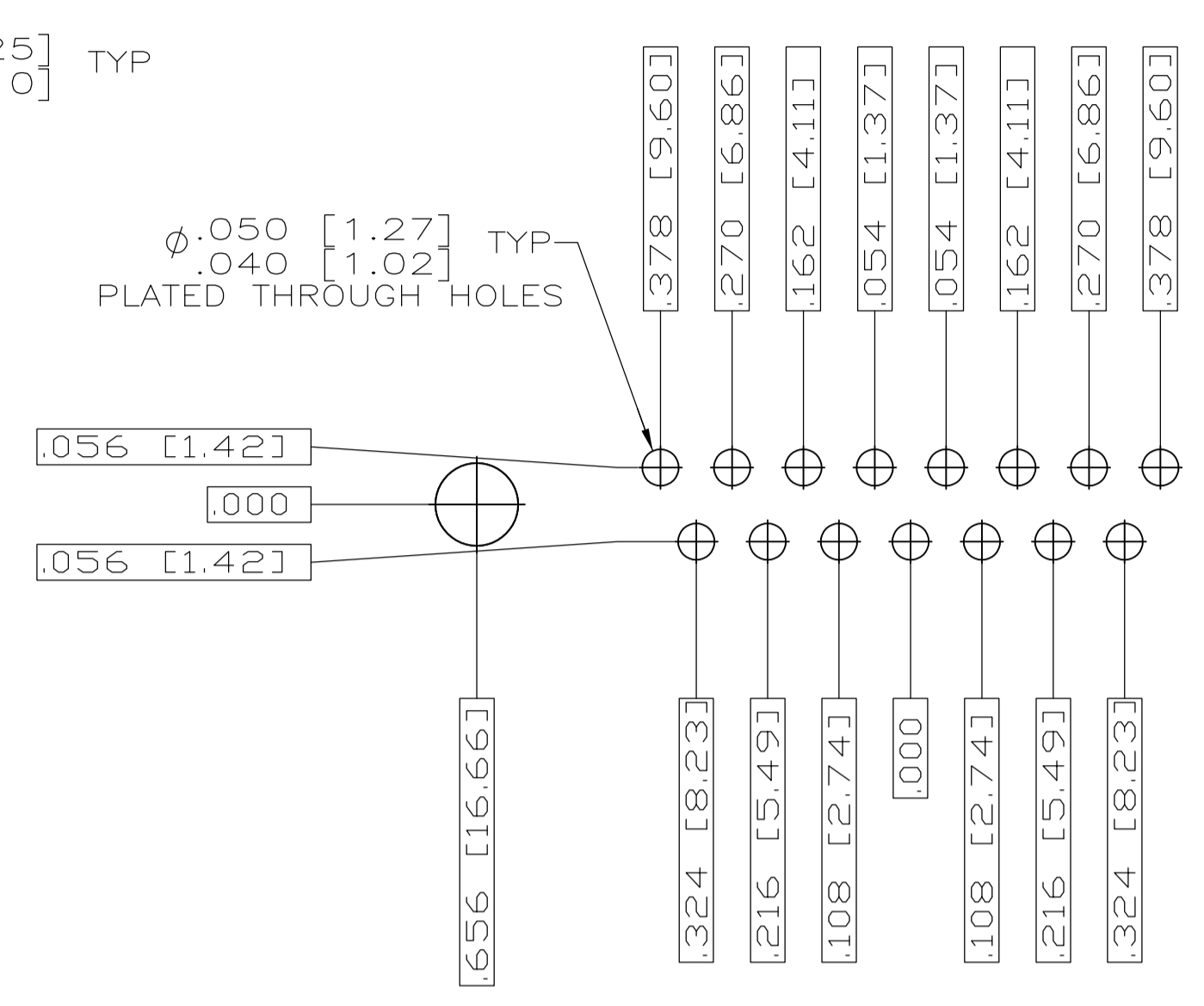

RECOMMENDED P.C. BOARD LAYOUT
 SHELL SIZE 2 (15 POSITION) Δ

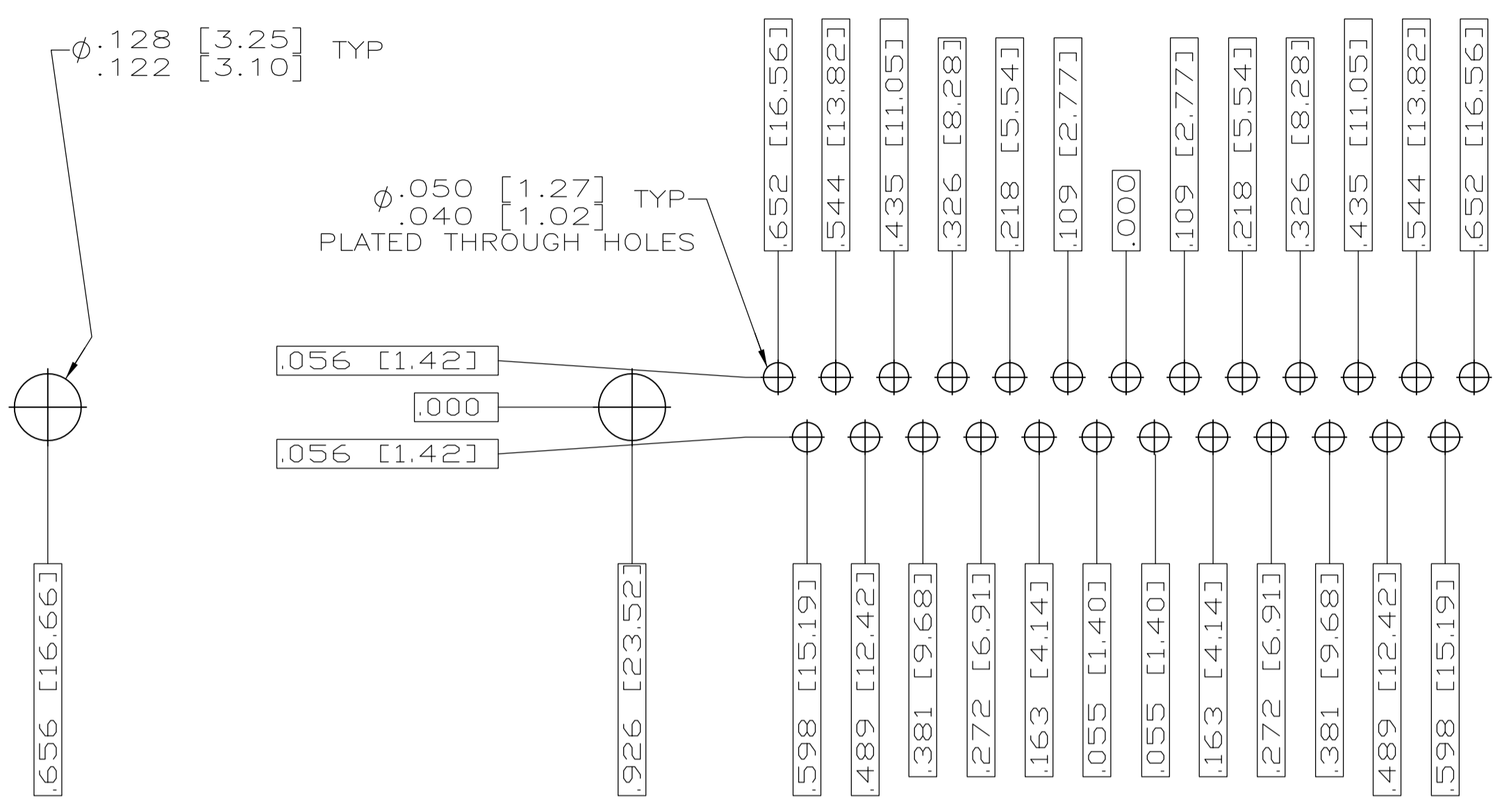

RECOMMENDED P.C. BOARD LAYOUT
 SHELL SIZE 3 (25 POSITION) Δ

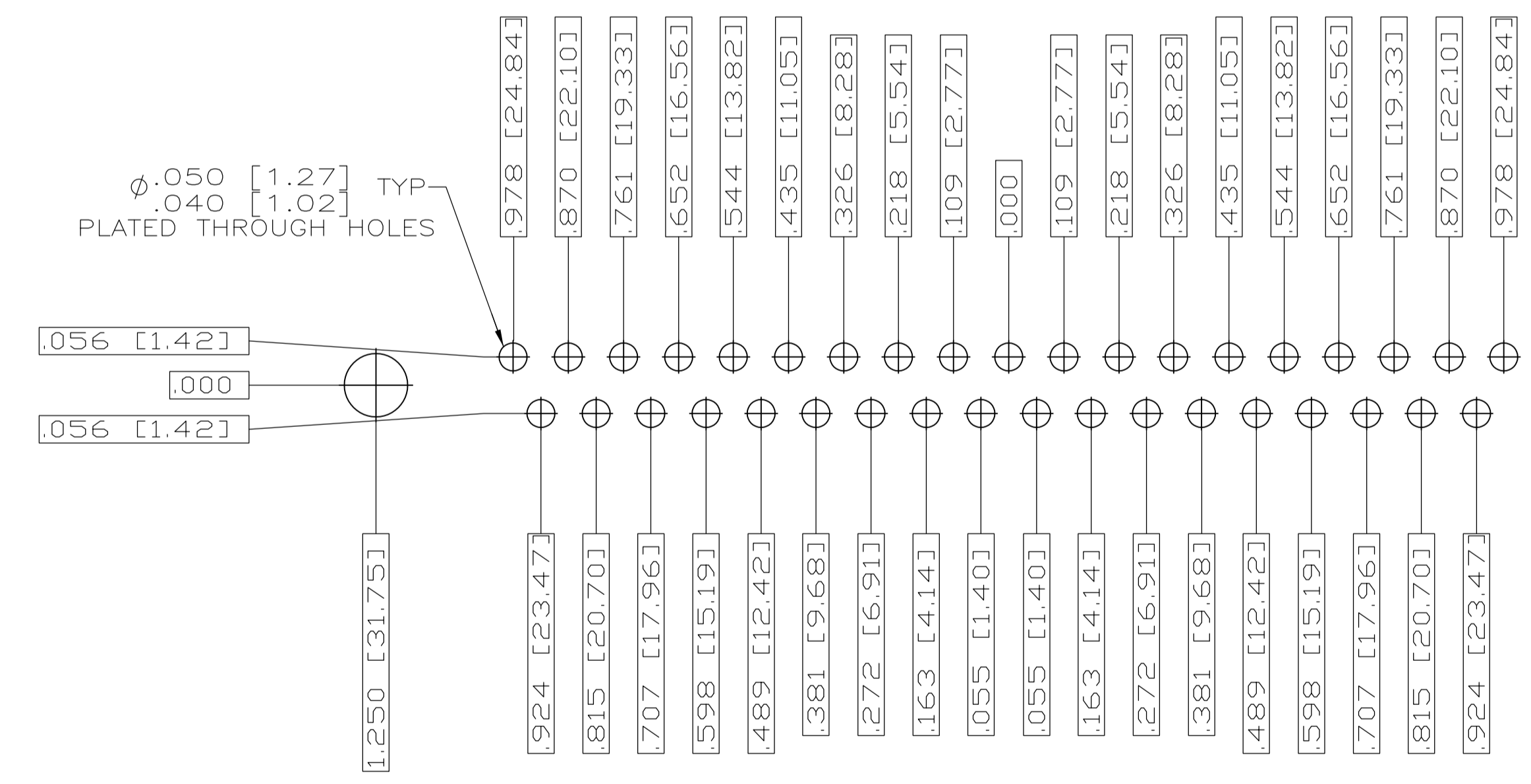

RECOMMENDED P.C. BOARD LAYOUT
 SHELL SIZE 4 (37 POSITION) Δ

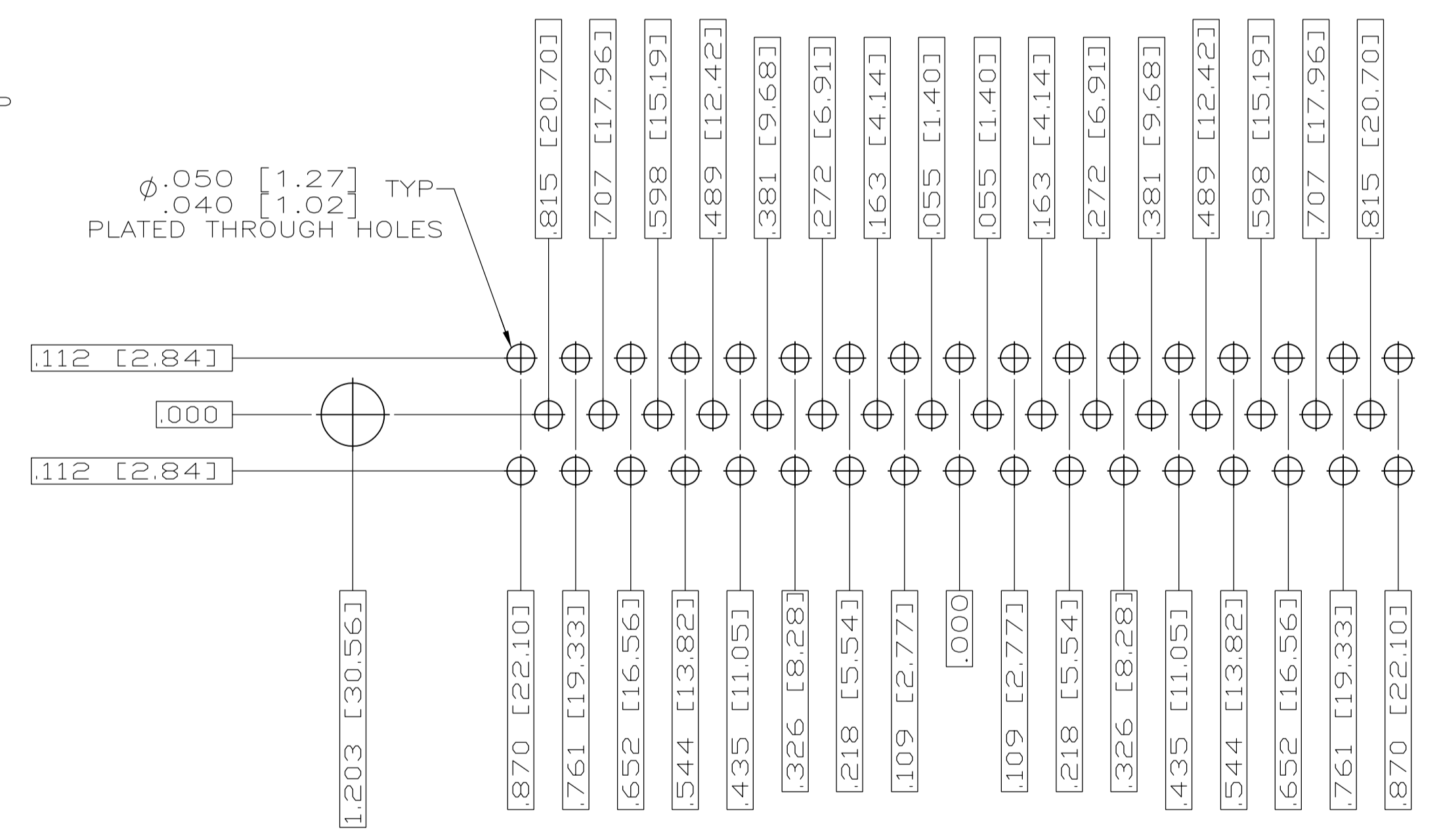

RECOMMENDED P.C. BOARD LAYOUT
 SHELL SIZE 5 (50 POSITION) Δ

THIS DRAWING IS A CONTROLLED DOCUMENT.		DIN C.C.THOMAS 2-23-06	TE Connectivity
DIMENSIONS: INCHES		CHK D.HOFFMAN 2-23-06	
TOLERANCES UNLESS OTHERWISE SPECIFIED:		APVD D.MILLER 2-23-06	NAME PLUG ASSY,AMPLIMITE RIGHT ANGLE,SERIES 109,SIZE 1 THRU 5
0 PL ± .005 1 PL ± .005 2 PL ± .005 3 PL ± .005 4 PL ± .005 ANGLES ± .1°		APPLICATION SPEC	SIZE A1
MATERIAL SEE CALLOUTS		WEIGHT	CAGE CODE 00779
		FINISH SEE CALLOUTS	DRAWING NO 1757837
			RESTRICTED TO
		CUSTOMER DRAWING	SCALE 4:1 SHEET 2 OF 2 REV B

X-ON Electronics

Largest Supplier of Electrical and Electronic Components

Click to view similar products for [D-Sub MIL Spec Connectors](#) category:

Click to view products by [TE Connectivity](#) manufacturer:

Other Similar products are found below :

[M85049/50-5F](#) [MDM-21PH046F](#) [850-056-0812](#) [1218697-4](#) [1484349-1](#) [17D25HV](#) [1996840-1](#) [243082-15](#) [1757682-1](#) [17D-E51218-1](#)
[17SDA15S](#) [1883533-1](#) [1883886-1](#) [1883889-1](#) [192900-0377](#) [M24308/8-347](#) [M83513/03-E09C](#) [443961-3](#) [MDM-21PH041F](#) [MDM-](#)
[21PH048F](#) [5-1218949-1](#) [550-031NF1R6K](#) [3-1236089-2](#) [550E001NF1R3J0L](#) [550T001NF1R6K0L](#) [557T283NF5B08](#) [DB121073-56](#)
[DC121073157](#) [443869-3](#) [443869-4](#) [443869-5](#) [550S004NF1R1B0F03](#) [557E283NF1A06](#) [527-019NF0303R2K1F](#) [5-446405-1](#) [550-](#)
[031NF1R2E](#) [550E003M2R9J0F04](#) [550E003M3R9J0F05](#) [550E024M104R9J0](#) [550E024NF102R3J0B](#) [550E039NF1R3J1-02](#)
[550S003M3R9B0F05](#) [550S004M4R7M0F04](#) [550S004NF1R1B1F02](#) [550S008M3F0K0F04](#) [550S086M5R3J0L](#) [550S100NF3F0E](#)
[550T001M2R7E0L](#) [550T001NF1F0B1L](#) [550T001NF1R1K0G](#)