

1. SEE SHEET 2 FOR RECOMMENDED P.C. BOARD LAYOUT. TRUE POSITION TOLERANCE FOR P.C. BOARD LAYOUT IS .010 [0.25] AT MAX MATERIAL CONDITION. SUGGESTED BOARD THICKNESS IS .062 [1.57]
2. THE CONNECTORS DESCRIBED IN THIS DOCUMENT MEET THE REQUIREMENTS OF MIL-C-24308 AND MATE WITH ANY PLUG CONNECTOR WITH SAME INSERT ARRANGEMENT.
3. MARKED WITH .047 [1.19]-.062 [1.57] HIGH CHARACTERS. FAR SIDE REFERS TO THE WIDE SIDE OF THE KEYSTONE. NEAR SIDE REFERS TO THE NARROW SIDE OF THE KEYSTONE. IF THE SHELL IS TOO SMALL FOR ENTIRE MARKING MARKING SHALL BE SPLIT AS FOLLOWS:
 - A. "M24308" ON FRONT SHELL, FAR SIDE.
 - B. SLASH SHEET AND DASH NUMBER ON REAR SHELL, FAR SIDE.
 - C. "MFG'S" (NAME, BRAND OR LOGO) AND DATE CODE ON FRONT SHELL, NEAR SIDE.
 - D. MFG'S PART NUMBER ON REAR SHELL, NEAR SIDE.
4. REQUIREMENT FOR FULL PIN DIAMETER EXTENSION: .159 [4.04] MIN FOR SHELL SIZE 1 THRU 2; .150 [3.81] MIN FOR SHELL SIZE 3, 4 & 5.
5. SOLDER DIPPED PER J-STD-001 WITH Sn63 SOLDER PER J-STD-006 IN THE ENTIRE AREA OF DIMENSION SHOWN. (1757827-6 THRU -10 ONLY.)
6. MEETS SOLDERABILITY PER MIL-STD-202 METHOD 208.
7. SPACERS (QTY = 2) ARE SUPPLIED WITH CONNECTOR; NOT ATTACHED.

MFG'S (NAME, BRAND OR LOGO), MFG'S PART NO. AND DATE CODE MARKED ON FAR SIDE

SHELL, FRONT & REAR
MATL: STEEL PER ASTM A 109 OR EQUIVALENT
FINISH: ZINC PLATED .000200 [0.0051] MIN THK PER ASTM-B-633; YELLOW CHROMATE

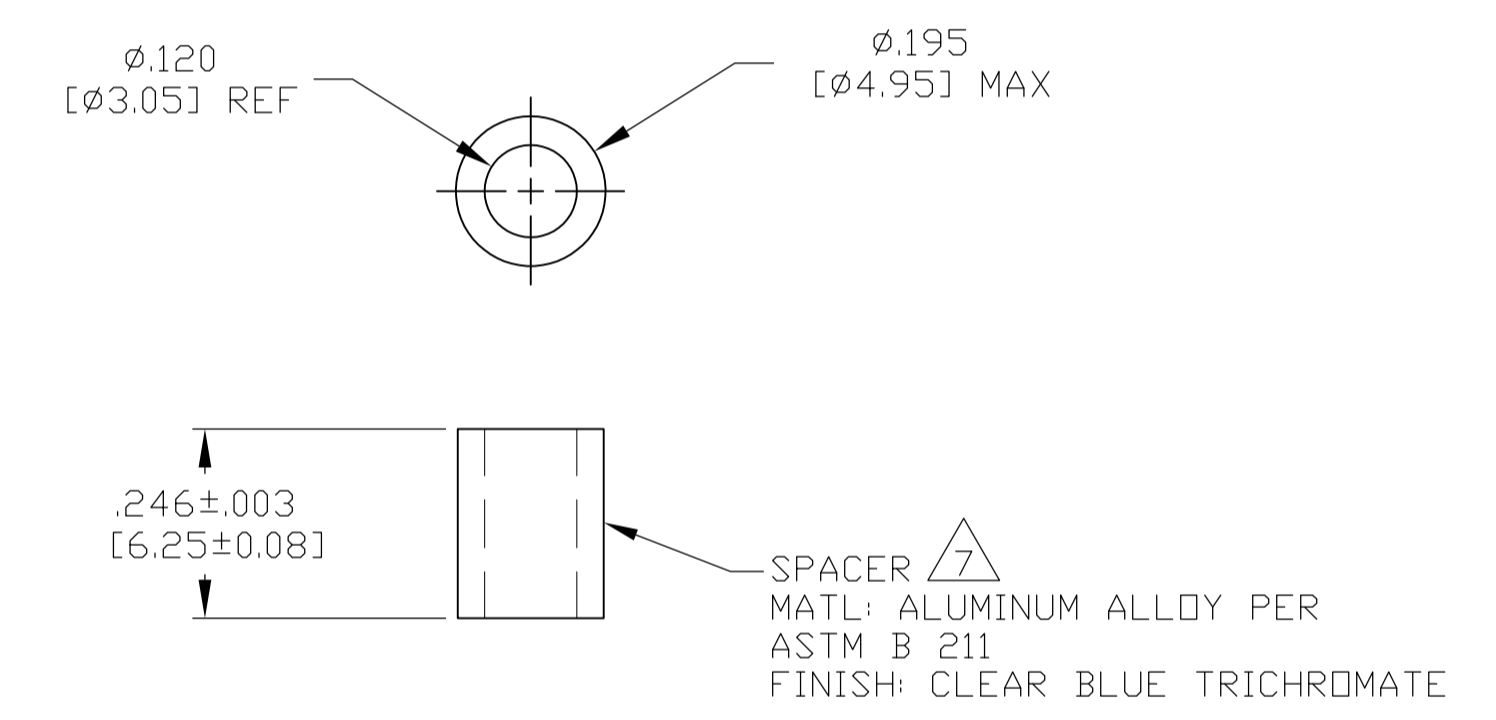
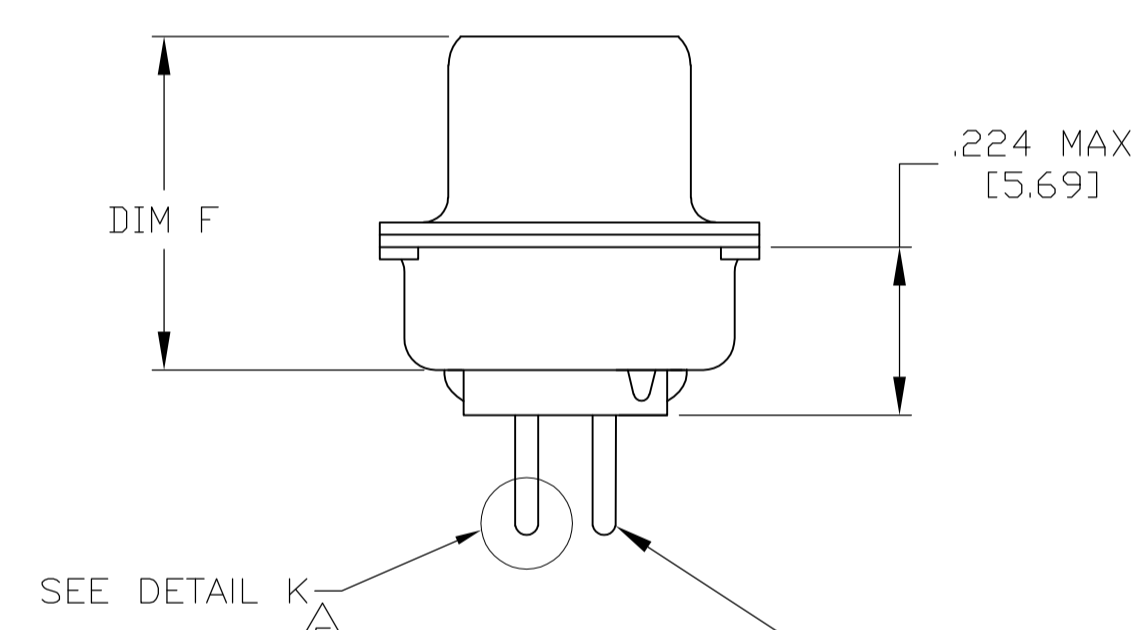
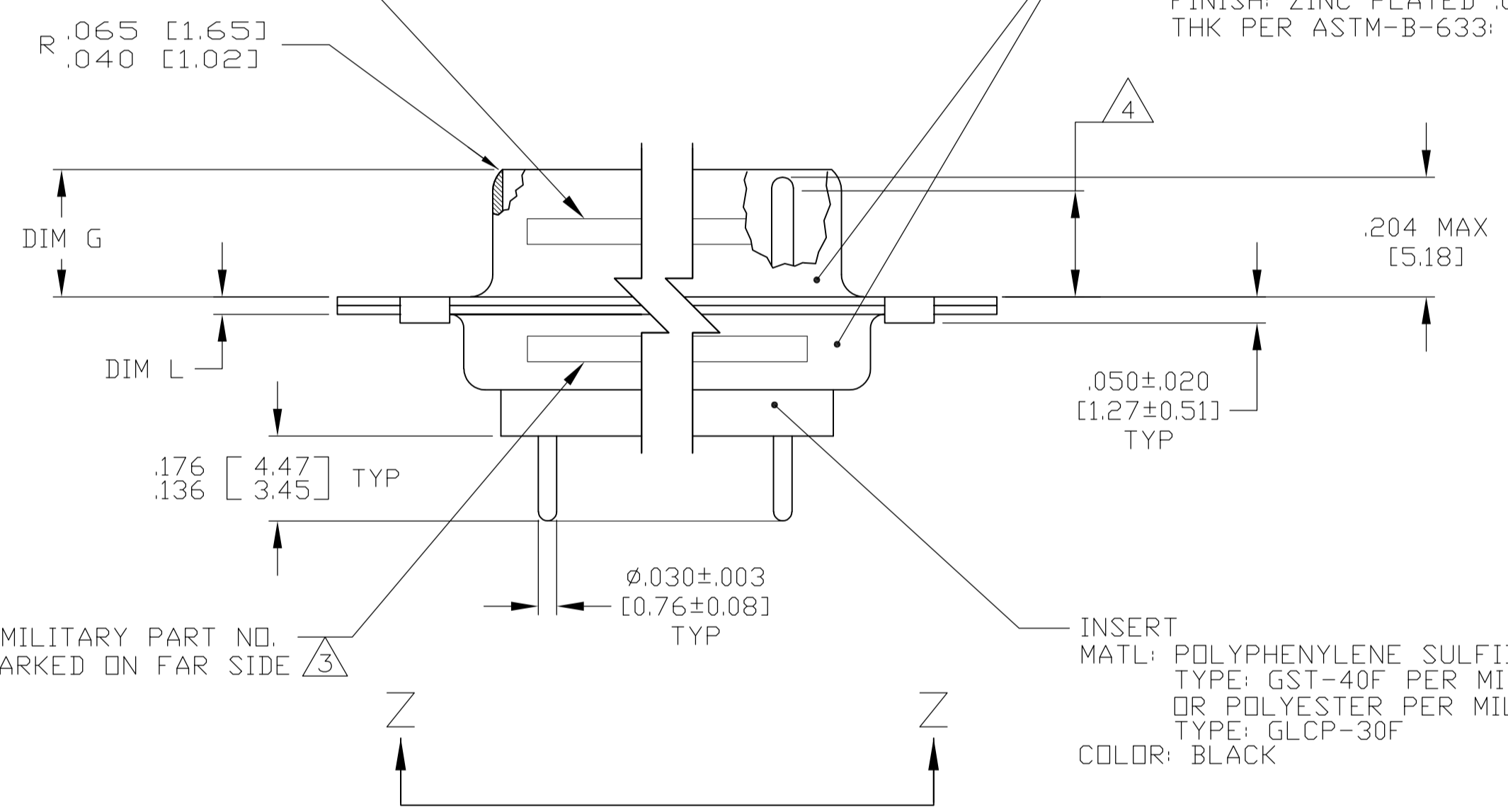

CONTACT (QTY = NO. OF POSN)
MATL: BRASS PER ASTM-B-16, OR BERYLLIUM COPPER PER ASTM-B-194
FINISH: GOLD PER ASTM-B-488, TYPE II, GRADE C, CLASS 1.27 IN CONTACT MATING AREA, .000010 [0.0003] MIN THK GOLD PER ASTM-B-488 OVER .000050 [0.0013] MIN THK NICKEL PER SAE-AMS-QQ-N-290 ON CONTACT BODY

MILITARY PART NO. MARKED ON FAR SIDE

INSERT
MATL: POLYPHENYLENE SULFIDE (PPS) TYPE: GST-40F PER MIL-M-24519, OR POLYESTER PER MIL-M-24519, TYPE: GLCP-30F COLOR: BLACK

.049	[1.24]	.544	[13.82]	2.188	[55.58]	.236	[5.99]	.436	[11.07]	.620	[15.75]	.446	[11.33]	2.411	[61.24]	2.084	[52.93]	2.650	[67.31]	MS18277-1	50	5	M24308/24-5Z	1757827-5	1-1757827-0
.029	[0.74]	.524	[13.31]	2.168	[55.07]	.224	[5.69]	.416	[10.57]	.590	[14.99]	.436	[11.07]	2.401	[60.99]	2.074	[52.68]	2.620	[66.55]	MS18277-1	50	5	M24308/24-5Z	1757827-5	1757827-5
.049	[1.24]	.432	[10.97]	2.282	[57.96]	.236	[5.99]	.436	[11.07]	.509	[12.93]	.334	[8.48]	2.505	[63.63]	2.187	[55.55]	2.744	[69.70]	MS18276-1	37	4	M24308/24-4Z	1757827-4	1757827-9
.029	[0.74]	.412	[10.46]	2.262	[57.45]	.224	[5.69]	.416	[10.57]	.479	[12.17]	.324	[8.23]	2.495	[63.37]	2.177	[55.30]	2.714	[68.94]	MS18276-1	37	4	M24308/24-4Z	1757827-4	1757827-4
.049	[1.24]	.432	[10.97]	1.635	[41.53]	.236	[5.99]	.436	[11.07]	.509	[12.93]	.334	[8.48]	1.857	[47.17]	1.539	[39.09]	2.103	[53.42]	MS18275-1	25	3	M24308/24-3Z	1757827-3	1757827-8
.029	[0.74]	.412	[10.46]	1.615	[41.02]	.224	[5.69]	.416	[10.57]	.479	[12.17]	.324	[8.23]	1.847	[46.91]	1.529	[38.84]	2.073	[52.65]	MS18275-1	25	3	M24308/24-3Z	1757827-3	1757827-3
.040	[1.02]	.432	[10.97]	1.093	[27.76]	.238	[6.05]	.432	[10.97]	.509	[12.93]	.334	[8.48]	1.317	[33.45]	.999	[25.37]	1.556	[39.52]	MS18274-1	15	2	M24308/24-2Z	1757827-2	1757827-7
.020	[0.51]	.412	[10.46]	1.073	[27.25]	.229	[5.82]	.412	[10.46]	.479	[12.17]	.324	[8.23]	1.307	[33.20]	.989	[25.12]	1.526	[38.76]	MS18274-1	15	2	M24308/24-2Z	1757827-2	1757827-2
.040	[1.02]	.432	[10.97]	.769	[19.53]	.238	[6.05]	.432	[10.97]	.509	[12.93]	.334	[8.48]	.989	[25.12]	.671	[17.04]	1.228	[31.19]	MS18273-1	9	1	M24308/24-1Z	1757827-1	1757827-6
.020	[0.51]	.412	[10.46]	.749	[19.02]	.229	[5.82]	.412	[10.46]	.479	[12.17]	.324	[8.23]	.979	[24.87]	.661	[16.79]	1.198	[30.43]	MS18273-1	9	1	M24308/24-1Z	1757827-1	1757827-6
.049	[1.24]	.544	[13.82]	2.188	[55.58]	.236	[5.99]	.436	[11.07]	.620	[15.75]	.446	[11.33]	2.411	[61.24]	2.084	[52.93]	2.650	[67.31]	MS18277-1	50	5	M24308/24-5Z	1757827-5	1757827-5
.029	[0.74]	.524	[13.31]	2.168	[55.07]	.224	[5.69]	.416	[10.57]	.590	[14.99]	.436	[11.07]	2.401	[60.99]	2.074	[52.68]	2.620	[66.55]	MS18277-1	50	5	M24308/24-5Z	1757827-5	1757827-5
.049	[1.24]	.432	[10.97]	2.282	[57.96]	.236	[5.99]	.436	[11.07]	.509	[12.93]	.334	[8.48]	2.505	[63.63]	2.187	[55.55]	2.744	[69.70]	MS18276-1	37	4	M24308/24-4Z	1757827-4	1757827-4
.029	[0.74]	.412	[10.46]	2.262	[57.45]	.224	[5.69]	.416	[10.57]	.479	[12.17]	.324	[8.23]	2.495	[63.37]	2.177	[55.30]	2.714	[68.94]	MS18276-1	37	4	M24308/24-4Z	1757827-4	1757827-4
.049	[1.24]	.432	[10.97]	1.635	[41.53]	.236	[5.99]	.436	[11.07]	.509	[12.93]	.334	[8.48]	1.857	[47.17]	1.539	[39.09]	2.103	[53.42]	MS18275-1	25	3	M24308/24-3Z	1757827-3	1757827-3
.029	[0.74]	.412	[10.46]	1.615	[41.02]	.224	[5.69]	.416	[10.57]	.479	[12.17]	.324	[8.23]	1.847	[46.91]	1.529	[38.84]	2.073	[52.65]	MS18275-1	25	3	M24308/24-3Z	1757827-3	1757827-3
.040	[1.02]	.432	[10.97]	1.093	[27.76]	.238	[6.05]	.432	[10.97]	.509	[12.93]	.334	[8.48]	1.317	[33.45]	.999	[25.37]	1.556	[39.52]	MS18274-1	15	2	M24308/24-2Z	1757827-2	1757827-2
.020	[0.51]	.412	[10.46]	1.073	[27.25]	.229	[5.82]	.412	[10.46]	.479	[12.17]	.324	[8.23]	1.307	[33.20]	.989	[25.12]	1.526	[38.76]	MS18274-1	15	2	M24308/24-2Z	1757827-2	1757827-2
.040	[1.02]	.432	[10.97]	.769	[19.53]	.238	[6.05]	.432	[10.97]	.509	[12.93]	.334	[8.48]	.989	[25.12]	.671	[17.04]	1.228	[31.19]	MS18273-1	9	1	M24308/24-1Z	1757827-1	1757827-1
.020	[0.51]	.412	[10.46]	.749	[19.02]	.229	[5.82]	.412	[10.46]	.479	[12.17]	.324	[8.23]	.979	[24.87]	.661	[16.79]	1.198	[30.43]	MS18273-1	9	1	M24308/24-1Z	1757827-1	1757827-1
L	J	H	G	F	E	D	C	B	A	ARRANGEMENT	NO OF POS	SHELL SIZE	MILITARY P/N ON CONNECTOR	MFG'S P/N ON CONNECTOR	PART NUMBER										

.030 [0.76] MAX EXTENSION PERMISSIBLE DUE TO SOLDER DIPPING

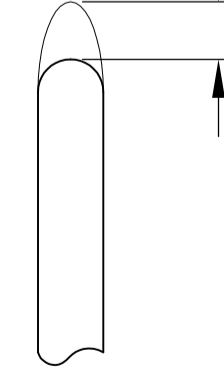

DETAIL K SCALE 10:1 FOR 1757827-6 THRU -10 ONLY

THIS DRAWING IS A CONTROLLED DOCUMENT.

DIMENSIONS: INCHES	TOLERANCES UNLESS OTHERWISE SPECIFIED:	DMN: C.C. THOMAS 3-28-06	APVD: D. MILLER 3-29-06	NAME: PLUG ASSEMBLY, AMPLIMITE, POSTED SERIES 109, SIZE 1 THRU 5
0 PLC ± .005	1 PLC ± .005	2 PLC ± .005	3 PLC ± .005	4 PLC ± .005
ANGLES ± 1°	APPLICATION SPEC: -			
MATERIAL: SEE CALLOUTS	FINISH: SEE CALLOUTS	WEIGHT: -	SIZE: A1	CAGE CODE: 00779
CUSTOMER DRAWING		SCALE: 4:1	SHEET: 1 OF 2	REV: C

STE TE Connectivity

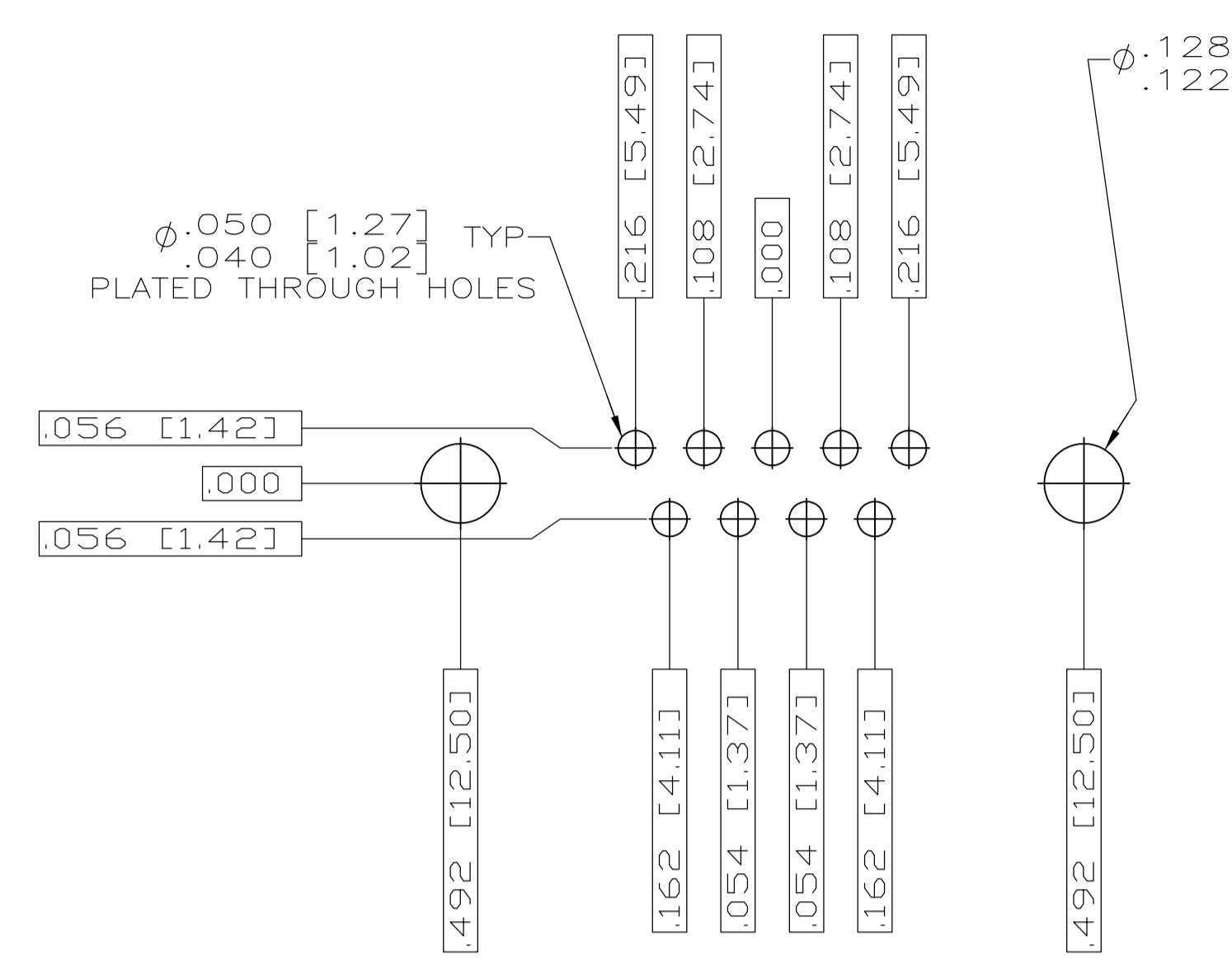

RECOMMENDED P.C. BOARD LAYOUT
SHELL SIZE 1 (9 POSITION) Δ

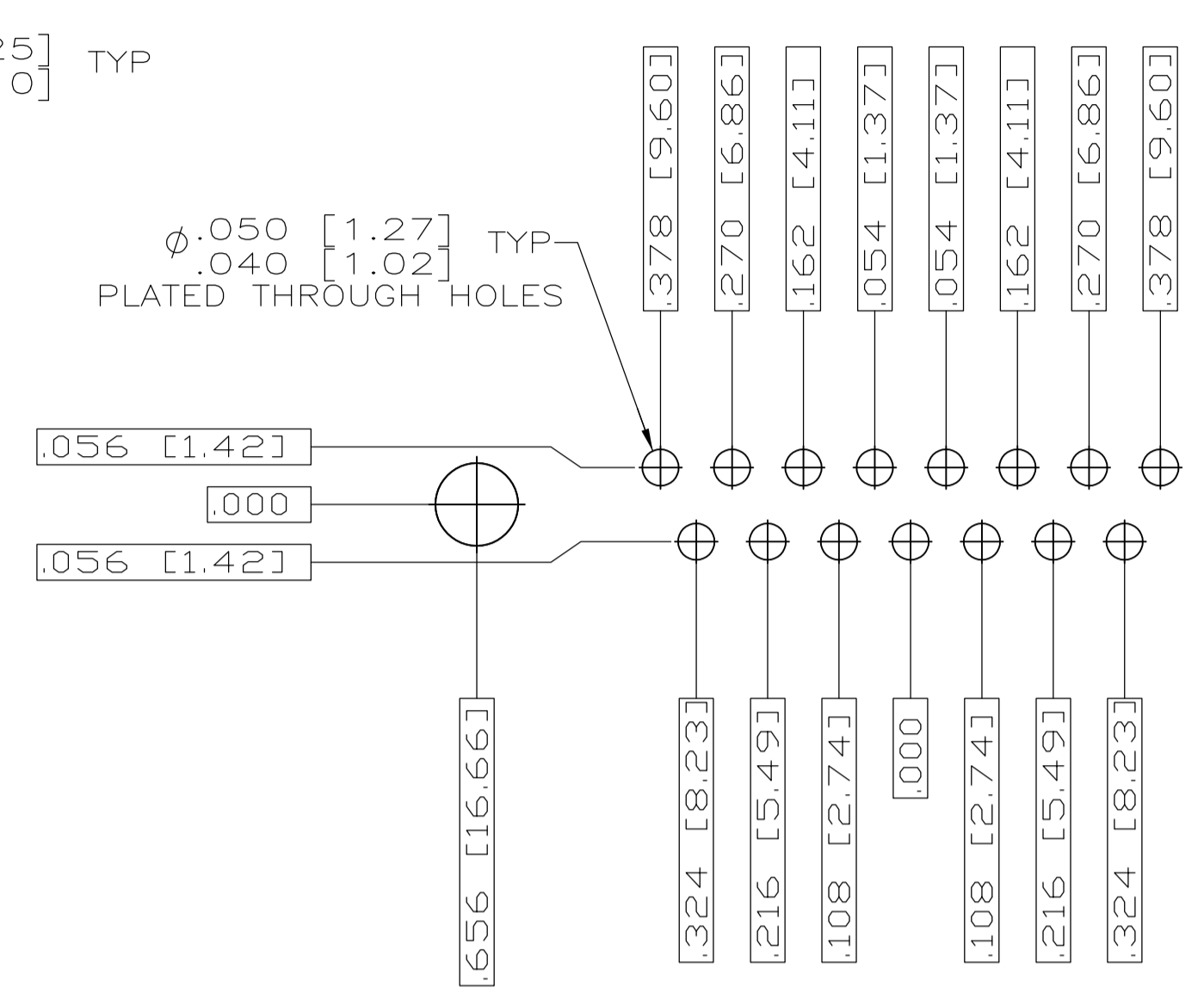

RECOMMENDED P.C. BOARD LAYOUT
SHELL SIZE 2 (15 POSITION) Δ

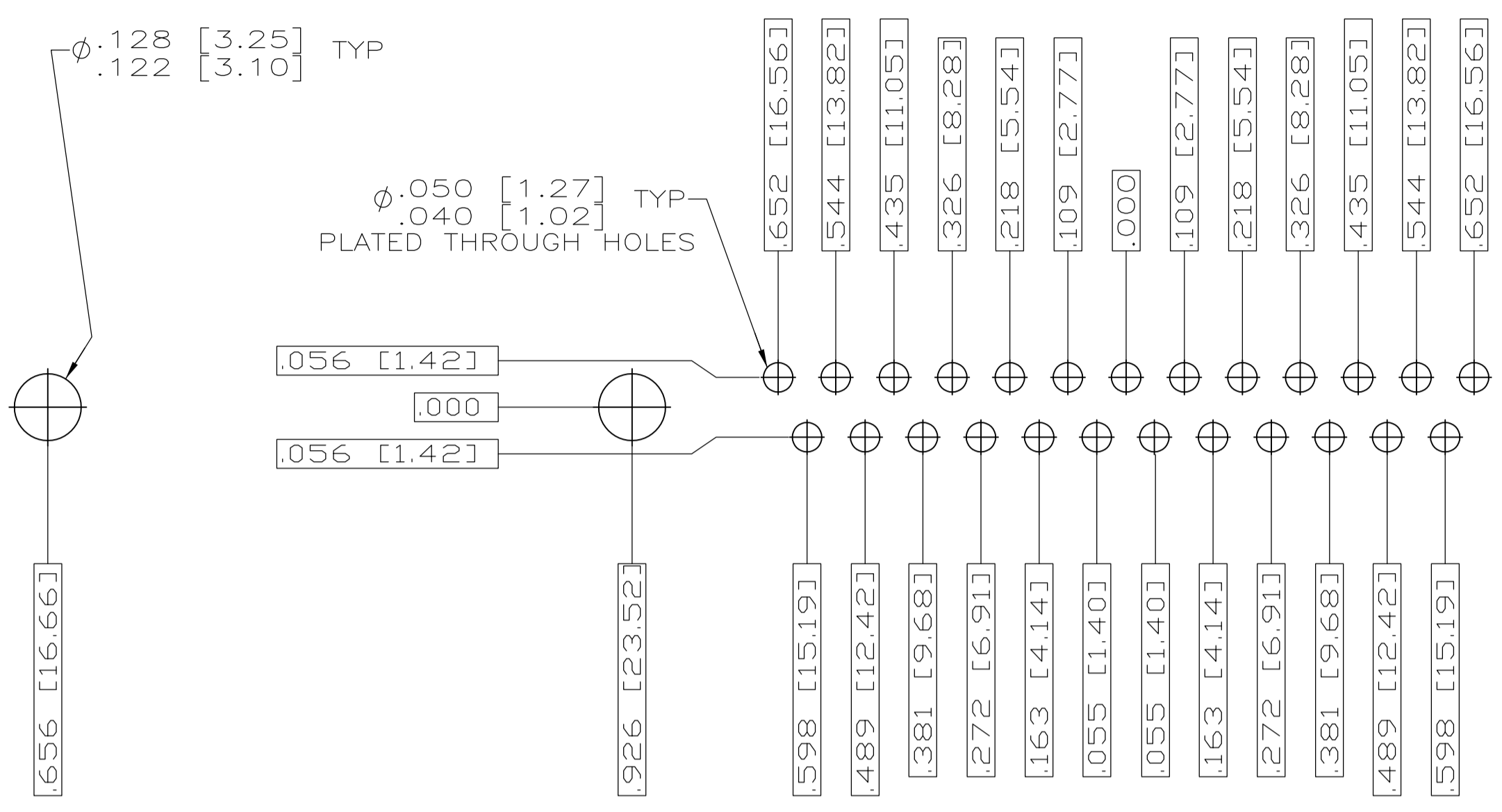

RECOMMENDED P.C. BOARD LAYOUT
SHELL SIZE 3 (25 POSITION) Δ

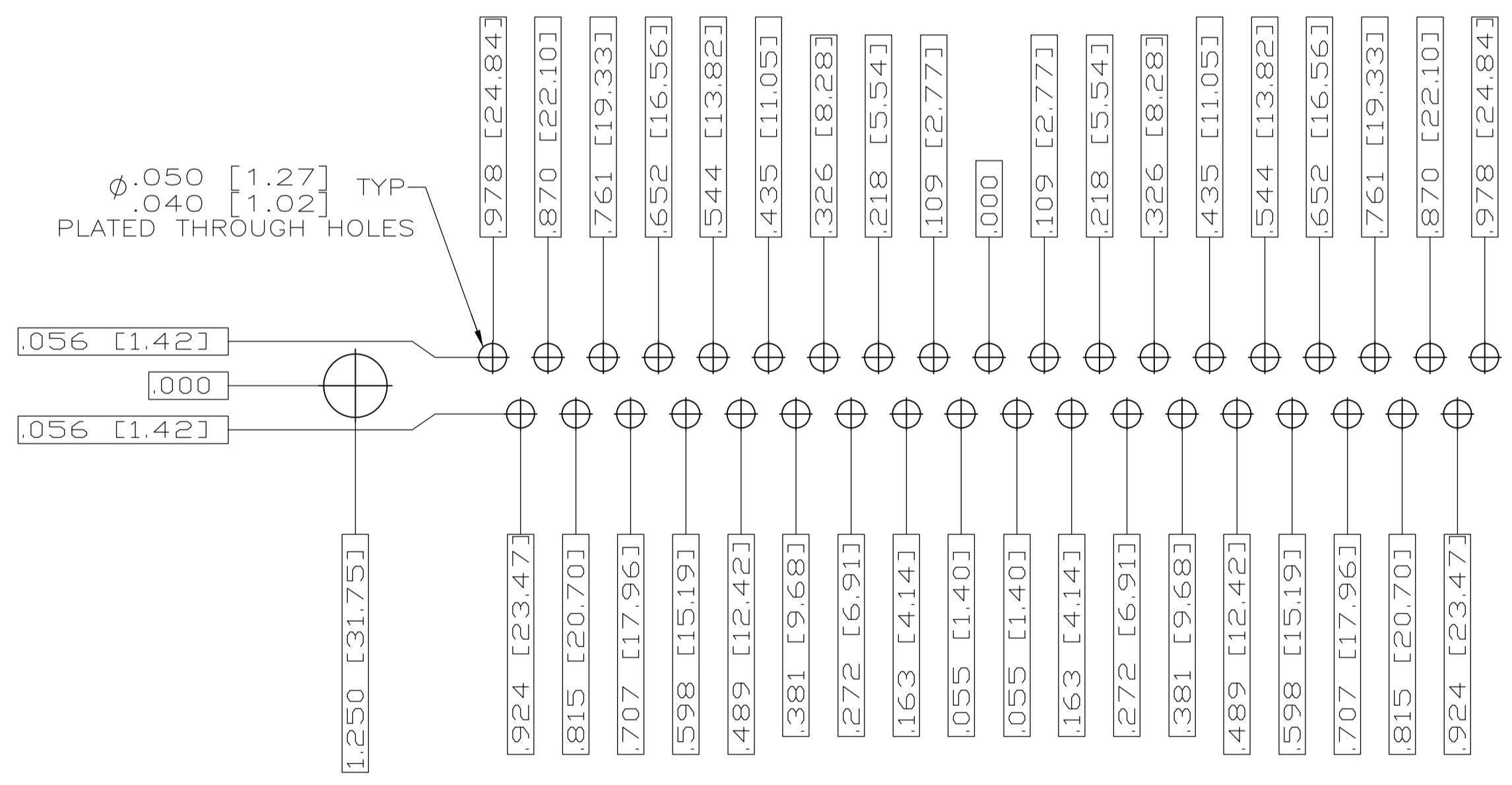

RECOMMENDED P.C. BOARD LAYOUT
SHELL SIZE 4 (37 POSITION) Δ

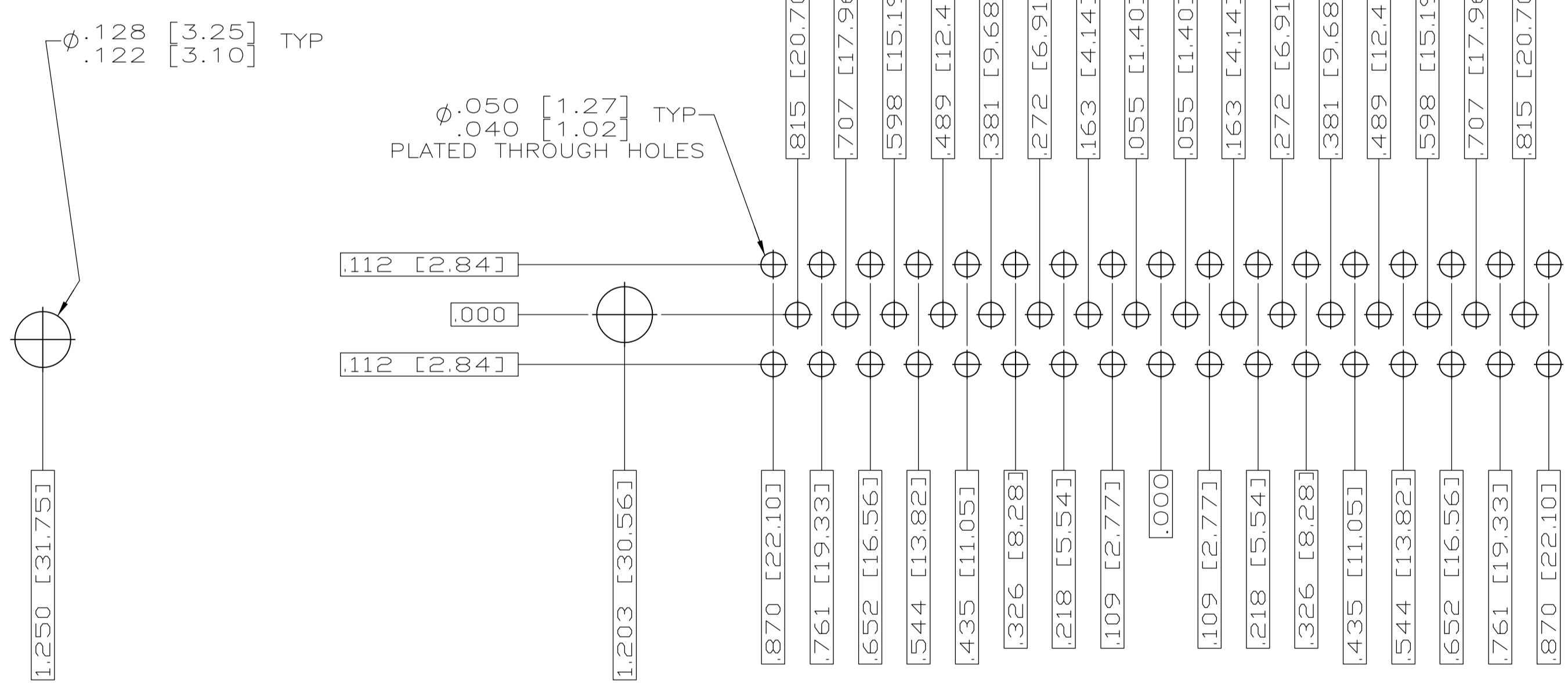

RECOMMENDED P.C. BOARD LAYOUT
SHELL SIZE 5 (50 POSITION) Δ

THIS DRAWING IS A CONTROLLED DOCUMENT.		DWN C.C.THOMAS 3-27-06 CHK D.MILLER 3-28-06 APVD D.MILLER 3-28-06 NAME PRODUCT SPEC APPLICATION SPEC WEIGHT CUSTOMER DRAWING	TE Connectivity PLUG ASSEMBLY,AMPLIMITE SERIES 109,SIZE 1 THRU 5 SIZE A1 CAGE CODE 00779 DRAWING NO. 1757827 SCALE 4:1 SHEET 2 OF 2 REV C
DIMENSIONS: INCHES TOLERANCES UNLESS OTHERWISE SPECIFIED: 0 PL ± .005 1 PL ± .005 2 PL ± .005 3 PL ± .005 4 PL ± .005 ANGLES ± .1°	FINISH SEE CALLOUTS	RESTRICTED TO -	

X-ON Electronics

Largest Supplier of Electrical and Electronic Components

Click to view similar products for [D-Sub MIL Spec Connectors](#) category:

Click to view products by [TE Connectivity](#) manufacturer:

Other Similar products are found below :

[M24308/4-13Z](#) [M8351307-B](#) [D38999/20FJ43HN](#) [D38999/24WG11PB-LC](#) [D38999/24WG41HN](#) [MDM-15PH041P](#) [MDM-21PH041P](#) [MDM-21SH003B-K139](#) [850-056-0812](#) [1218697-4](#) [DBMM25S](#) [MS27467T21F41S](#) [17D25HV](#) [1996840-1](#) [243082-15](#) [1663962-1](#) [1757682-1](#) [17D-E51218-1](#) [17SDA15S](#) [1883533-1](#) [1883886-1](#) [1883889-1](#) [192900-0377](#) [308-CP6P0441-024H](#) [M24308/2-3Z](#) [M24308/4-3Z](#) [M24308/4-4F](#) [M24308/4-4Z](#) [M24308/8-347](#) [M83513/03-E09C](#) [M83723/75W2212N L/C](#) [D38999/24FJ29PN-LC](#) [D38999/24WG11SB-LC](#) [MDM-21PH046P](#) [5-1218949-1](#) [550-031NF1R6K](#) [550E001NF1R3J0L](#) [550T001NF1R6K0L](#) [557T283NF5B08](#) [C115368-1612B](#) [C115370-1717B](#) [DC121073157](#) [443869-3](#) [443869-4](#) [443869-5](#) [550S004NF1R1B0F03](#) [550-031NF1R2E](#) [550E003M2R9J0F04](#) [550E003M3R9J0F05](#) [550E024M104R9J0](#)