

REVISED PER		ECO-11-005030	DATE	DWN	APVD
F1	REVISED PER	ECO-11-005030	11MAR11	RK	HMR

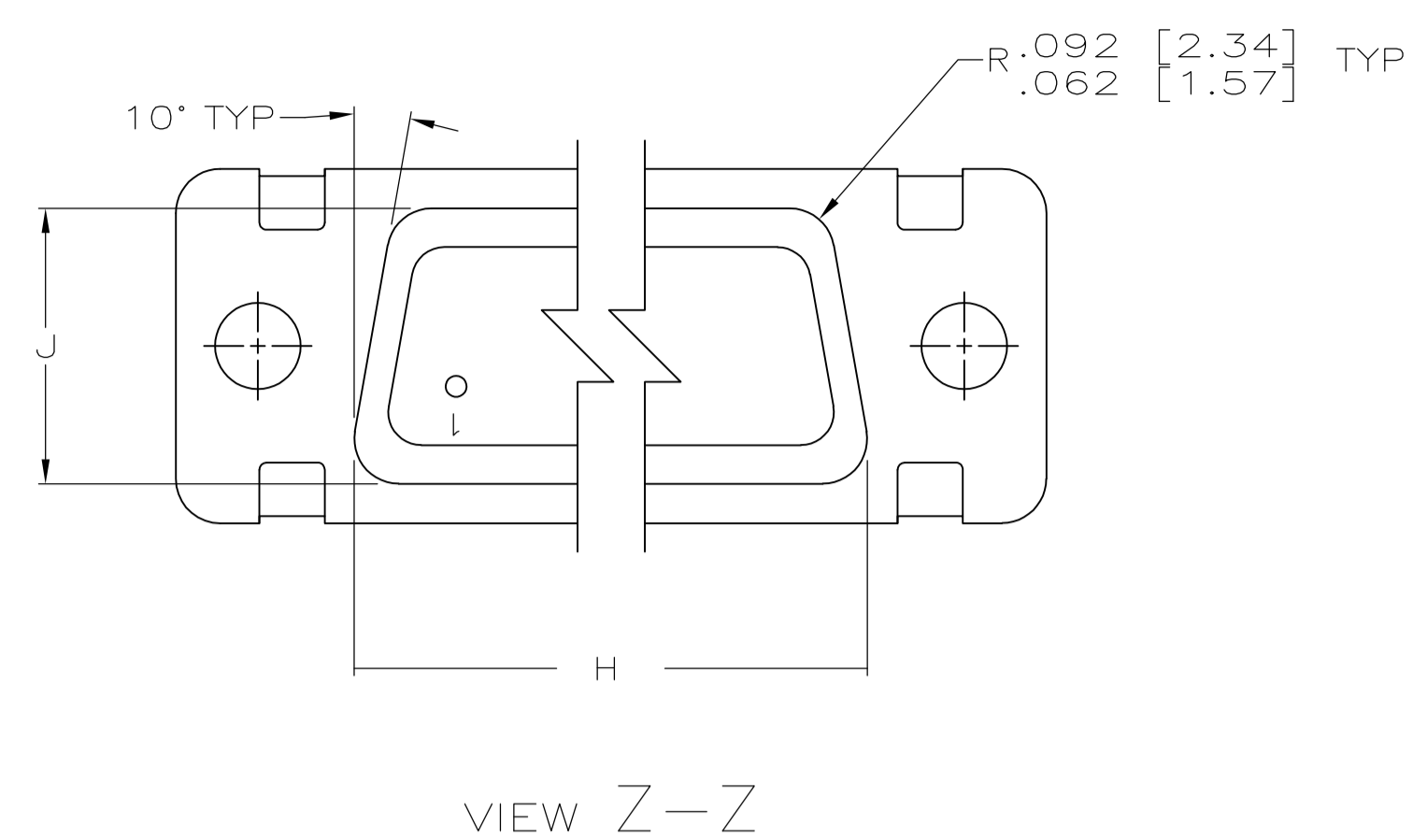

- 1 SEE SHEET 2 FOR RECOMMENDED P.C. BOARD LAYOUT. TRUE POSITION TOLERANCE FOR P.C. BOARD LAYOUT IS .010 [0.25] AT MAX MATERIAL CONDITION. SUGGESTED BOARD THICKNESS IS .094 [2.39]
- 2 THE CONNECTORS DESCRIBED IN THIS DOCUMENT MEET THE REQUIREMENTS OF MIL-C-24308 AND MATE WITH ANY RECEPTACLE CONNECTOR WITH SAME INSERT ARRANGEMENT.
- 3 MARK WITH .047 [1.19]-.062 [1.57] HIGH CHARACTERS. FAR SIDE REFERS TO THE WIDE SIDE OF THE KEYSTONE. NEAR SIDE REFERS TO THE NARROW SIDE OF THE KEYSTONE. IF THE REAR SHELL IS TOO SMALL FOR THE ENTIRE MILITARY PART NUMBER, MARKING SHALL BE LOCATED AS FOLLOWS:
 - A. "M24308" ON FRONT SHELL, FAR SIDE.
 - B. SLASH SHEET AND DASH NUMBER ON REAR SHELL, FAR SIDE.
 - C. "AMP" AND DATE CODE ON FRONT SHELL, NEAR SIDE.
 - D. PART NUMBER ON REAR SHELL, NEAR SIDE.
 IF THE FRONT SHELL IS TOO SMALL FOR "AMP", PART NUMBER AND DATE CODE, THEN SPLIT AS FOLLOWS:
 - A. PART NUMBER ON REAR SHELL, NEAR SIDE.
 - B. "AMP" AND DATE CODE ON FRONT SHELL, NEAR SIDE.
 - C. MILITARY PART NUMBER ON REAR SHELL, FAR SIDE.

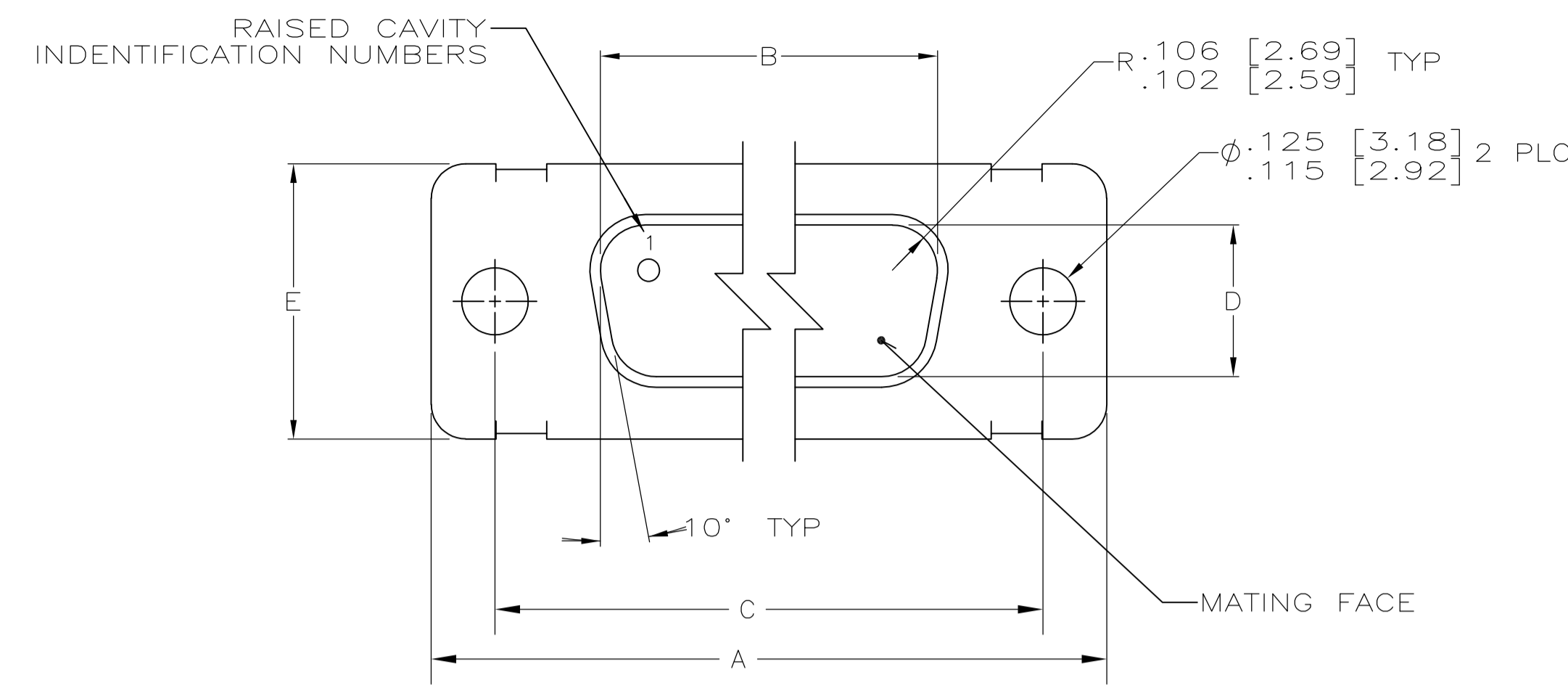
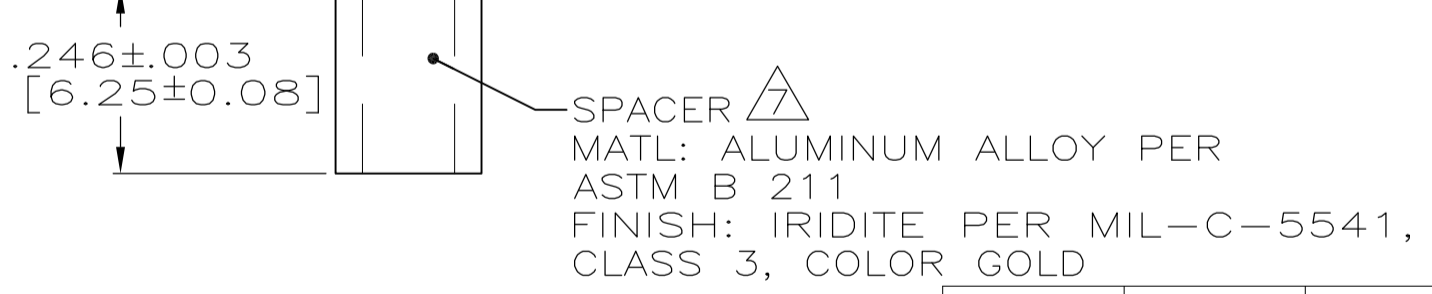
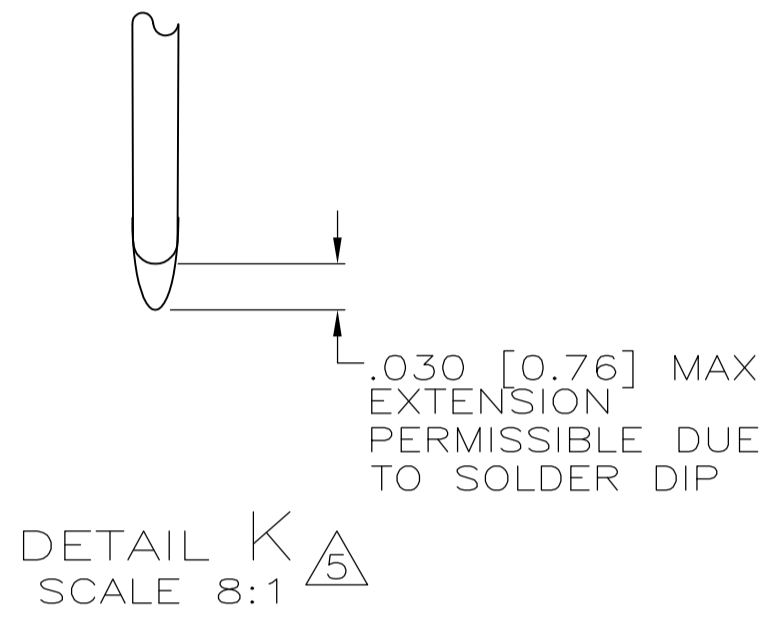
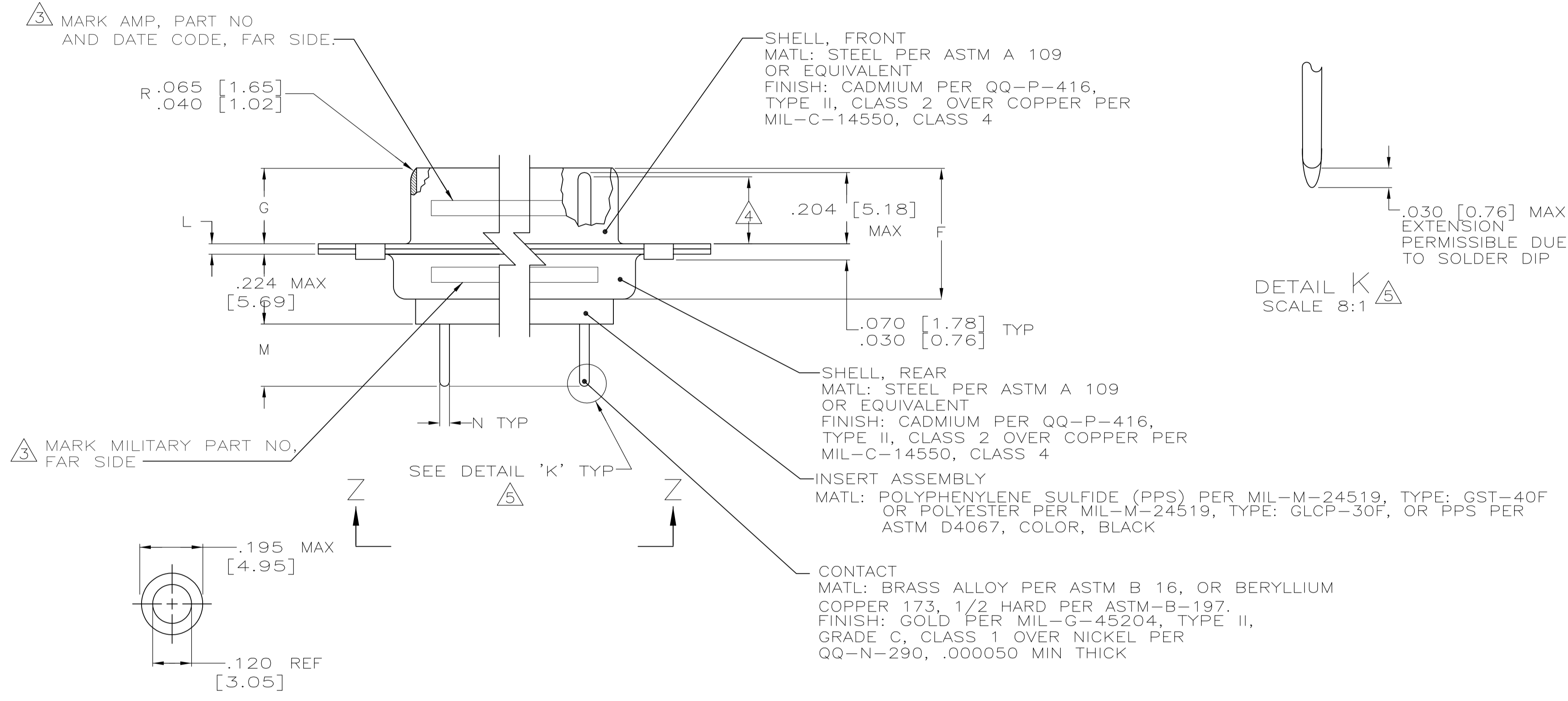

- 4 REQUIREMENT FOR FULL PIN DIAMETER EXTENSION: .159 [4.04] MIN, SHELL SIZES 1 AND 2. .150 [3.81] MIN, SHELL SIZES 3, 4, AND 5.
- 5 SOLDER DIP PER MIL-STD-2000 COMPOSITION Sn63 CONFORMING TO QQ-S-571. COVERAGE SHALL BE COMPLETE TO A DISTANCE .020 [0.51] MAX FROM INSERT ASSEMBLY.
- 6. THE SOLDER DIP PROCESS IS PERFORMED SUBSEQUENT TO THE COMPLETION OF PRODUCTION OF THE MILITARY QUALIFIED CONNECTOR. DIMENSIONS APPLY PRIOR TO SOLDER DIPPING.
- 7 SPACERS (QTY 2) ARE SUPPLIED WITH CONNECTORS (NOT ATTACHED TO THE CONNECTOR).
- 8. DIMENSIONS AND TOLERANCES PER ANSI Y14.5M-1982.
- 9. THIS DRAWING SHALL BE INTERPRETED IN ACCORDANCE WITH APPLICABLE STANDARDS LISTED IN MIL-STD-100.

N	M	L	J	H	G	F	E	D	C	B	A	INSERT ARRANGEMENT	NO OF POS	SHELL SIZE	MILITARY P/N ON CONNECTOR	P/N ON CONNECTOR	PART NUMBER
.033 .027	.208 .168	.049 .029	.544 [13.82] .524 [13.31]	2.188-55.58 2.168 [55.07]	.236 [5.99] .224 [5.69]	.436 [11.07] .416 [10.57]	.620 [15.75] .590 [14.99]	.446 [11.33] .436 [11.07]	2.411 [61.24] 2.401 [60.99]	2.084 [52.93] 2.074 [52.68]	2.650 [67.31] 2.620 [66.55]	MS18277-1	50	5	M24308/24-11F	1218125-5	1-1218125-0
			1.635-41.53 1.615 [41.02]	2.282-57.96 2.262 [57.45]								1.857 [47.17] 1.847 [46.91]	1.539 [39.09] 1.529 [38.84]	2.103 [53.42] 2.073 [52.65]	MS18276-1	37	4
.040 .020	1.02 0.51	.432 [10.97] .412 [10.46]	1.093-27.76 1.073 [27.25]	.238 [6.05] .229 [5.82]	.432 [10.97] .412 [10.46]	.509 [12.93] .479 [12.17]	.334 [8.48] .324 [8.23]	1.317 [33.45] 1.307 [33.20]	.999 [25.37] .989 [25.12]	1.556 [39.52] 1.526 [38.76]	1.228 [31.19] 1.198 [30.43]	MS18275-1	25	3	M24308/24-9F	1218125-3	1218125-8
			1.635-41.53 1.615 [41.02]									2.282-57.96 2.262 [57.45]	1.857 [47.17] 1.847 [46.91]	1.539 [39.09] 1.529 [38.84]	2.103 [53.42] 2.073 [52.65]	MS18274-1	15
.084 0.69	5.28 4.27	.049 .029	.544 [13.82] .524 [13.31]	2.188-55.58 2.168 [55.07]	.236 [5.99] .224 [5.69]	.436 [11.07] .416 [10.57]	.620 [15.75] .590 [14.99]	.446 [11.33] .436 [11.07]	2.411 [61.24] 2.401 [60.99]	2.084 [52.93] 2.074 [52.68]	2.650 [67.31] 2.620 [66.55]	MS18273-1	9	1	M24308/24-7F	1218125-1	1218125-6
			1.635-41.53 1.615 [41.02]	2.282-57.96 2.262 [57.45]								1.857 [47.17] 1.847 [46.91]	1.539 [39.09] 1.529 [38.84]	2.103 [53.42] 2.073 [52.65]	MS18277-1	50	5
.049 .029	1.24 0.74	.432 [10.97] .412 [10.46]	1.093-27.76 1.073 [27.25]	.238 [6.05] .229 [5.82]	.432 [10.97] .412 [10.46]	.509 [12.93] .479 [12.17]	.334 [8.48] .324 [8.23]	1.317 [33.45] 1.307 [33.20]	.999 [25.37] .989 [25.12]	1.556 [39.52] 1.526 [38.76]	1.228 [31.19] 1.198 [30.43]	MS18276-1	37	4	M24308/24-10F	1218125-4	1218125-4
			1.635-41.53 1.615 [41.02]									2.282-57.96 2.262 [57.45]	1.857 [47.17] 1.847 [46.91]	1.539 [39.09] 1.529 [38.84]	2.103 [53.42] 2.073 [52.65]	MS18275-1	25
.040 .020	1.02 0.51	.432 [10.97] .412 [10.46]	1.093-27.76 1.073 [27.25]	.238 [6.05] .229 [5.82]	.432 [10.97] .412 [10.46]	.509 [12.93] .479 [12.17]	.334 [8.48] .324 [8.23]	1.317 [33.45] 1.307 [33.20]	.999 [25.37] .989 [25.12]	1.556 [39.52] 1.526 [38.76]	1.228 [31.19] 1.198 [30.43]	MS18274-1	15	2	M24308/24-8F	1218125-2	1218125-2
			1.635-41.53 1.615 [41.02]									2.282-57.96 2.262 [57.45]	1.857 [47.17] 1.847 [46.91]	1.539 [39.09] 1.529 [38.84]	2.103 [53.42] 2.073 [52.65]	MS18273-1	9

THIS DRAWING IS A CONTROLLED DOCUMENT.

APPROVED: YEAGER 30DEC97
 CHK: G. OYER 30DEC97
 PRODUCT SPEC: WYNKOOP 30DEC97

NAME: AMPLIMITE PLUG ASSY, LOW PROFILE SIZE 20 POSTED, .030 DIA LONG POST SERIES 109, SHELL SIZES 1 THRU 5

SIZE: A1 CAGE CODE: 00779 DRAWING NO: 1218125 RESTRICTED TO: F1

CUSTOMER DRAWING SCALE: 4:1 SHEET: 1 OF 2 REV: F1

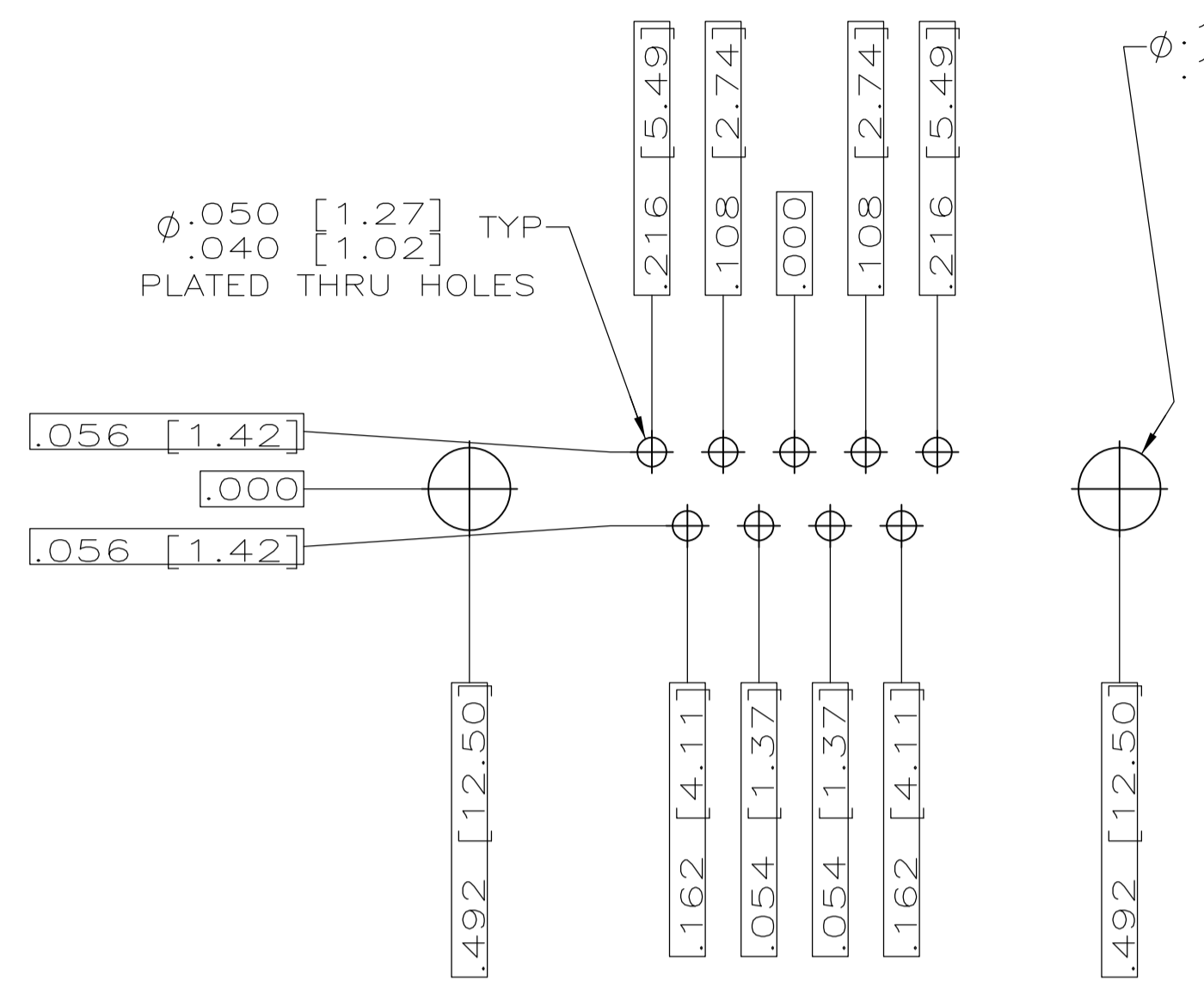

RECOMMENDED P.C. BOARD LAYOUT
SHELL SIZE 1 (9 POSITION) ⚠

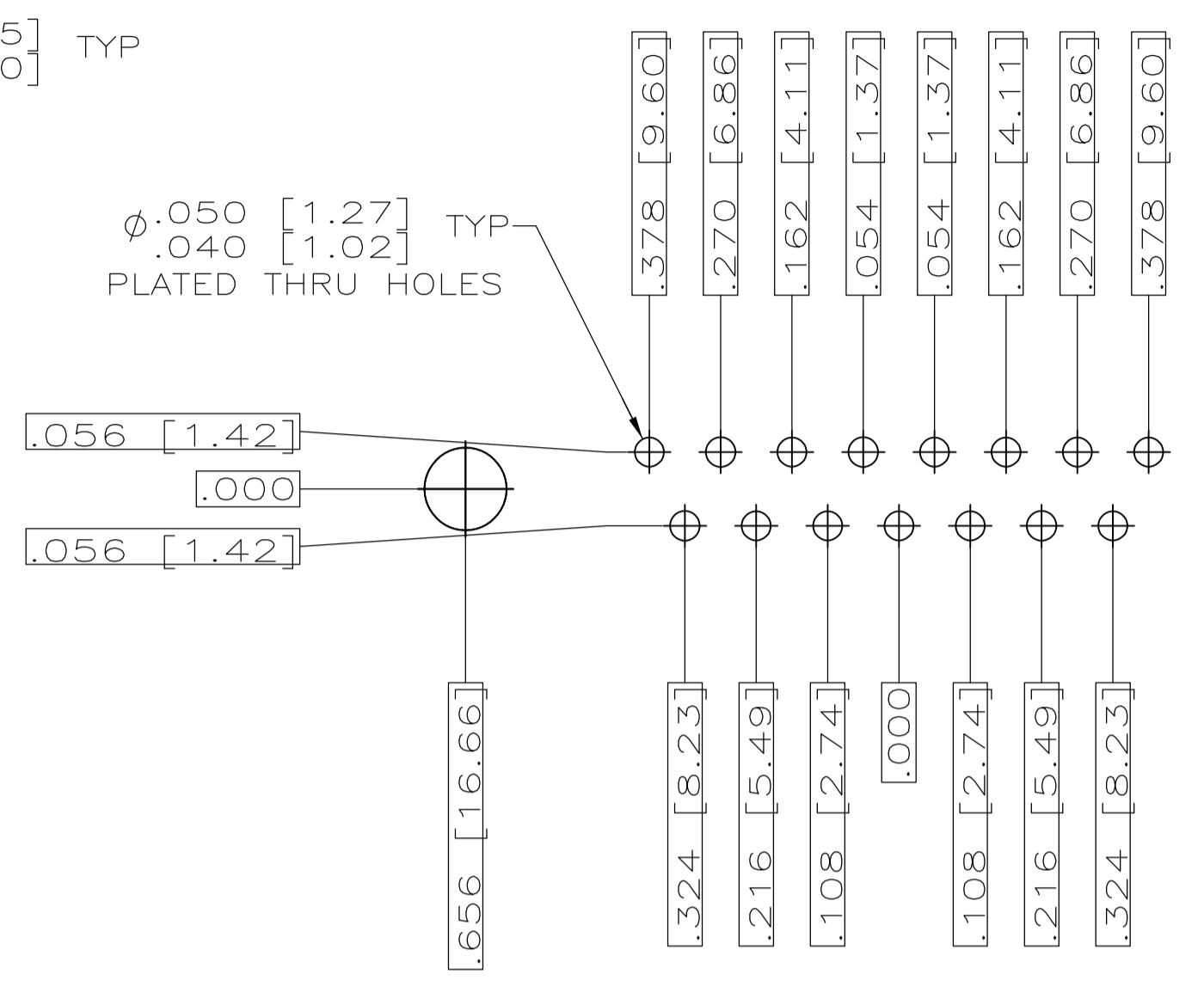

RECOMMENDED P.C. BOARD LAYOUT
SHELL SIZE 2 (15 POSITION) ⚠

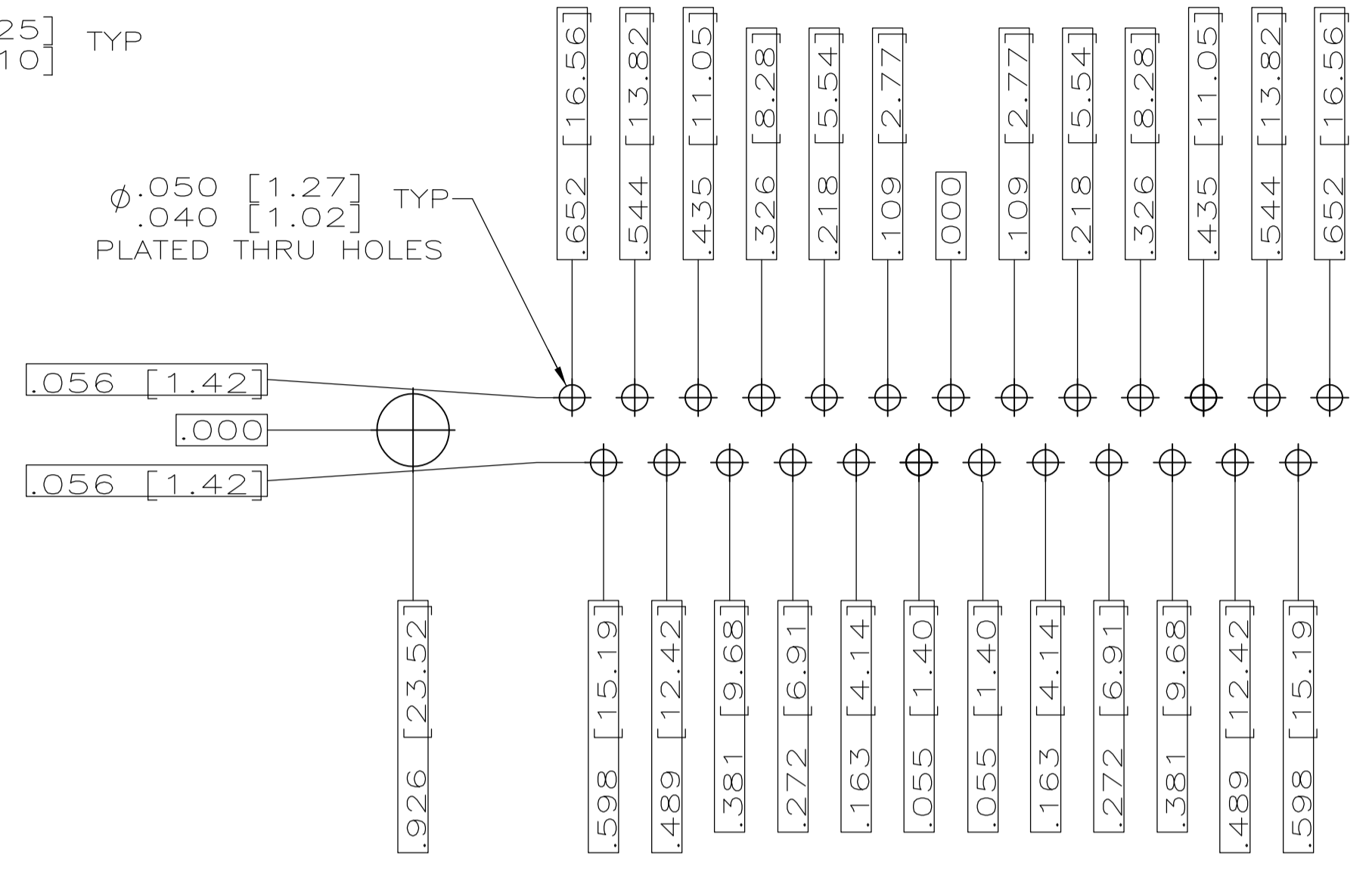

RECOMMENDED P.C. BOARD LAYOUT
SHELL SIZE 3 (25 POSITION) ⚠

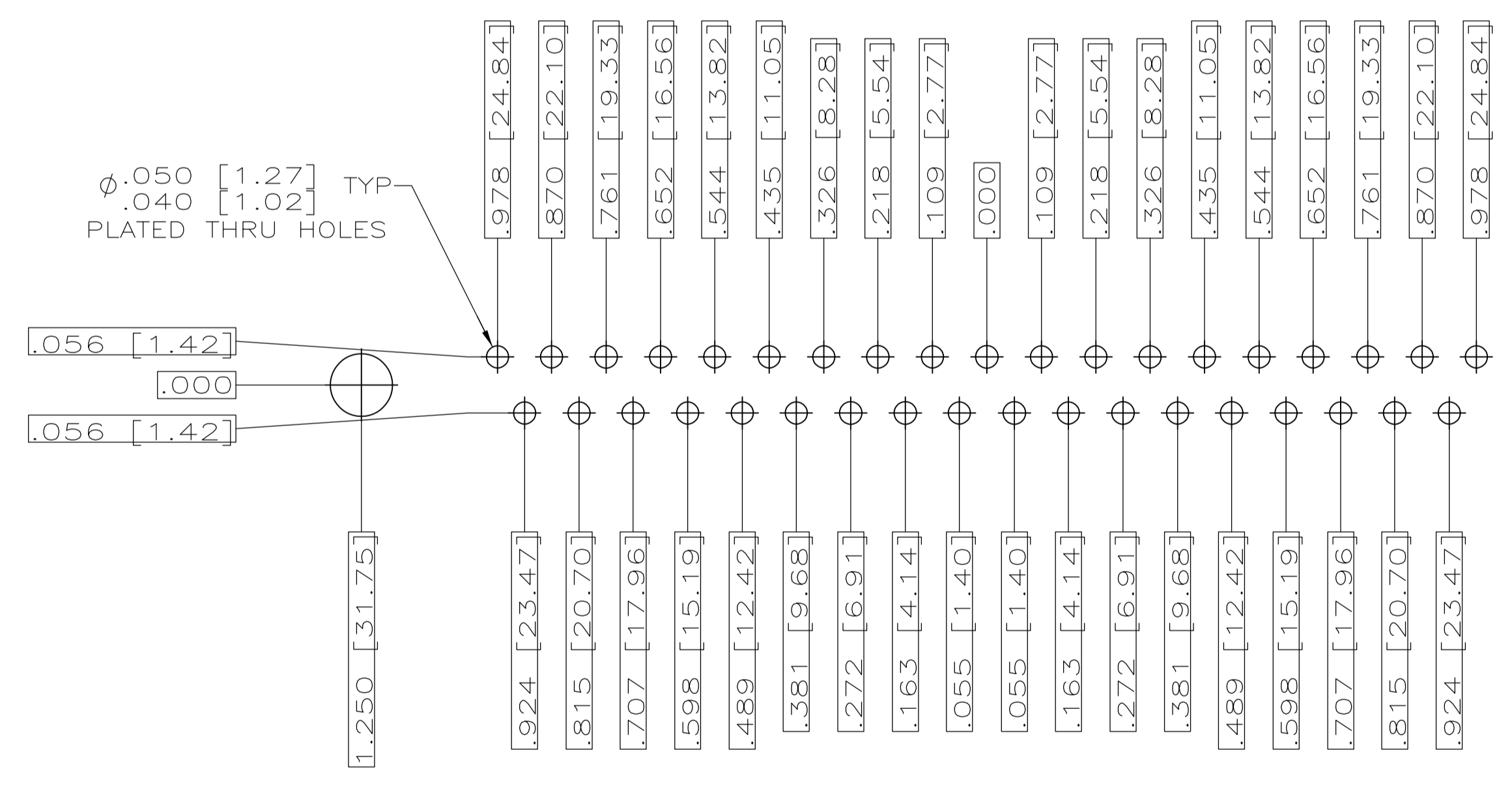

RECOMMENDED P.C. BOARD LAYOUT
SHELL SIZE 4 (37 POSITION) ⚠

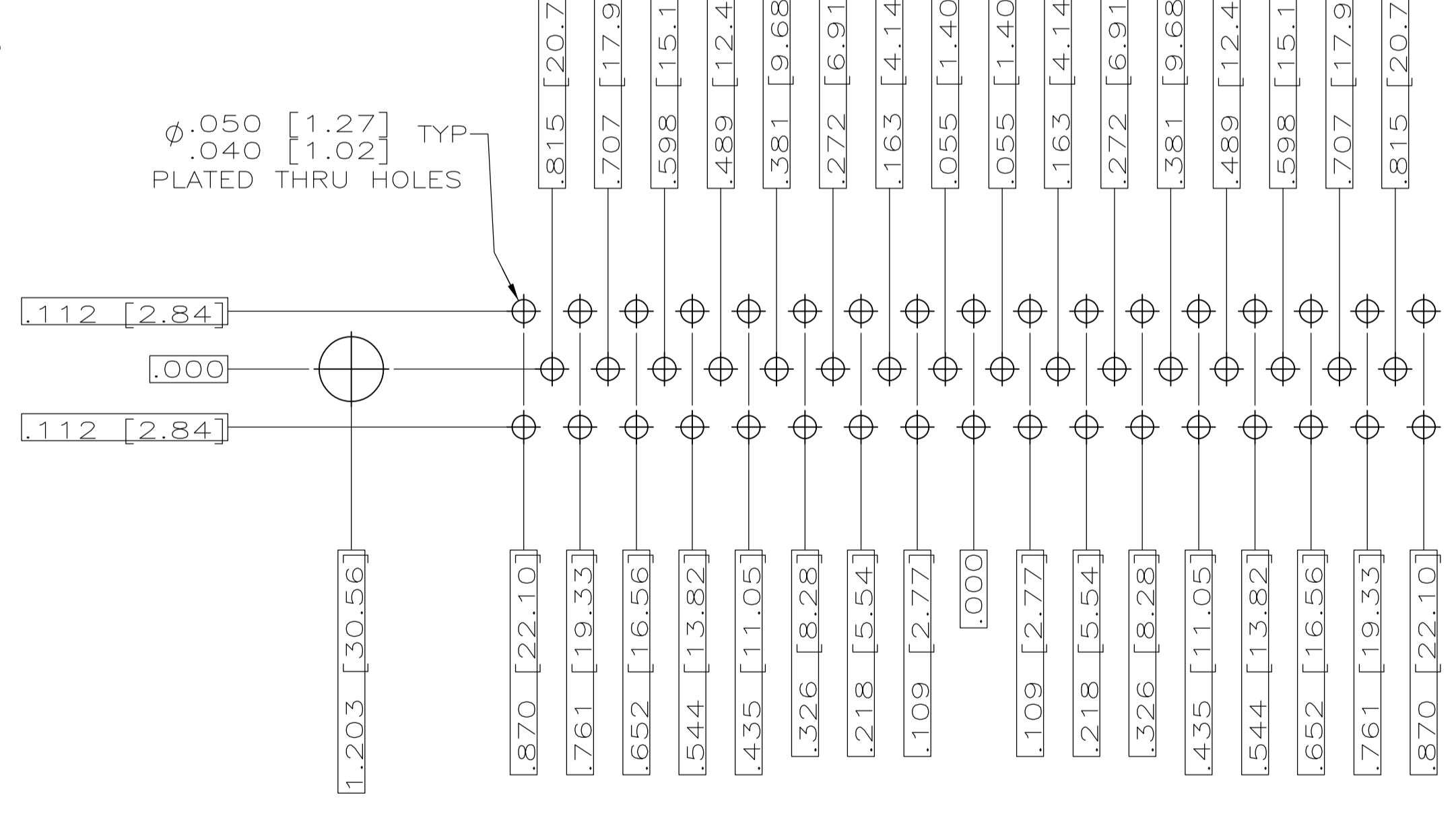

RECOMMENDED P.C. BOARD LAYOUT
SHELL SIZE 5 (50 POSITION) ⚠

THIS DRAWING IS A CONTROLLED DOCUMENT.		DIN P. YEAGER 30DEC97	 TE Connectivity
DIMENSIONS: INCHES		CHK G. OVER 30DEC97	
TOLERANCES UNLESS OTHERWISE SPECIFIED:		NAME	AMPLIMITE PLUG ASSY, LOW PROFILE SIZE 20 POSTED P.C. BOARD CONTACTS, .030 DIA LONG POST, SERIES 109.
0 PL ± .005 1 PL ± .005 2 PL ± .005 3 PL ± .005 4 PL ± .005 FINISH		PRODUCT SPEC APPLICATION SPEC WEIGHT CUSTOMER DRAWING	
MATERIAL		SIZE A1	RESTRICTED TO CASE CODE 00779 DRAWING NO. 1218125 SCALE 4:1 SHEET 2 OF 2 REV F1

X-ON Electronics

Largest Supplier of Electrical and Electronic Components

Click to view similar products for [D-Sub Mil Spec Connectors](#) category:

Click to view products by [TE Connectivity](#) manufacturer:

Other Similar products are found below :

[M85049/50-5F](#) [850-056-0812](#) [1218697-4](#) [1484349-1](#) [17D25HV](#) [1996840-1](#) [243082-15](#) [1757682-1](#) [17D-E51218-1](#) [17SDA15S](#) [1883533-1](#)
[1883886-1](#) [1883889-1](#) [192900-0377](#) [M24308/8-347](#) [M83513/03-E09C](#) [443961-3](#) [5-1218949-1](#) [550-031NF1R6K](#) [3-1236089-2](#)
[550E001NF1R3J0L](#) [550T001NF1R6K0L](#) [557T283NF5B08](#) [DB121073-56](#) [DC121073157](#) [443869-3](#) [443869-4](#) [443869-5](#)
[550S004NF1R1B0F03](#) [557E283NF1A06](#) [527-019NF0303R2K1F](#) [5-446405-1](#) [550-031NF1R2E](#) [550E003M2R9J0F04](#) [550E003M3R9J0F05](#)
[550E024M104R9J0](#) [550E024NF102R3J0B](#) [550E039NF1R3J1-02](#) [550S003M3R9B0F05](#) [550S004M4R7M0F04](#) [550S004NF1R1B1F02](#)
[550S008M3F0K0F04](#) [550S086M5R3J0L](#) [550S100NF3F0E](#) [550T001M2R7E0L](#) [550T001NF1F0B1L](#) [550T001NF1R1K0G](#)
[550T001NF1R3K0G](#) [550T001NF1R4K0L](#) [550T001NF2R2K0L](#)