

8 7 6 5 4 3 2 1

REVISIONS					
ZONE	LTR	ECN	DESCRIPTION	DATE	APPROVED
B		27054	NEW RELEASE	1/5/93	[Signature]

C Combine M & CD Dwg

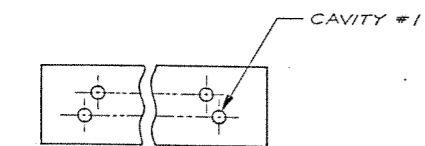
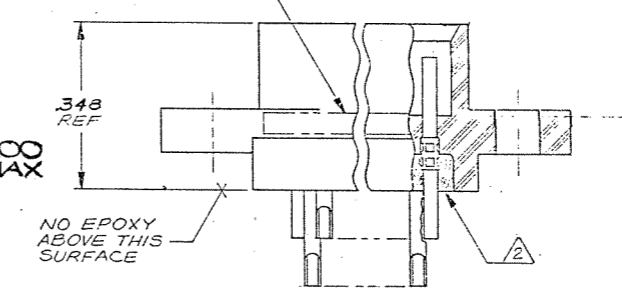
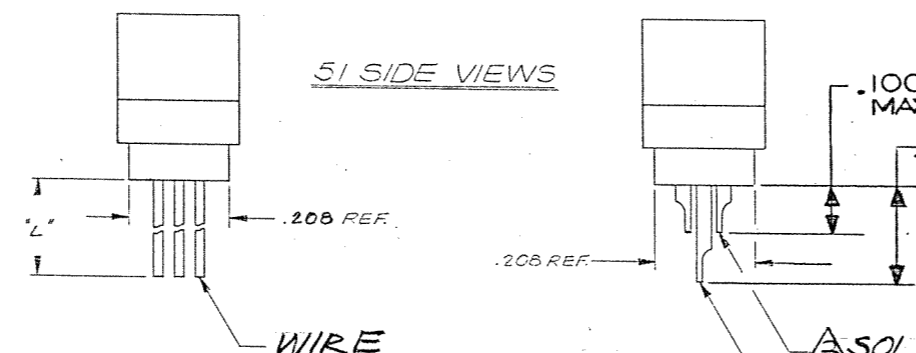
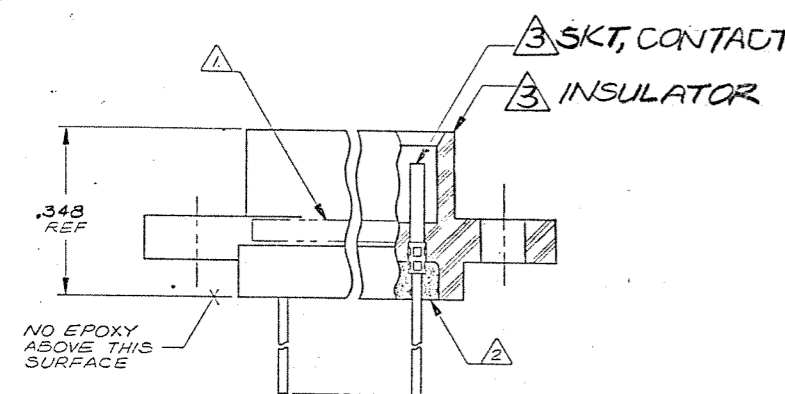
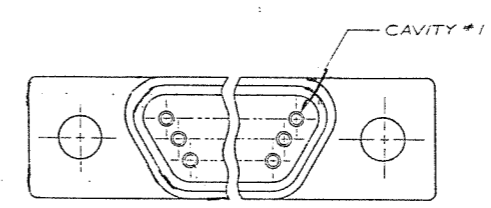
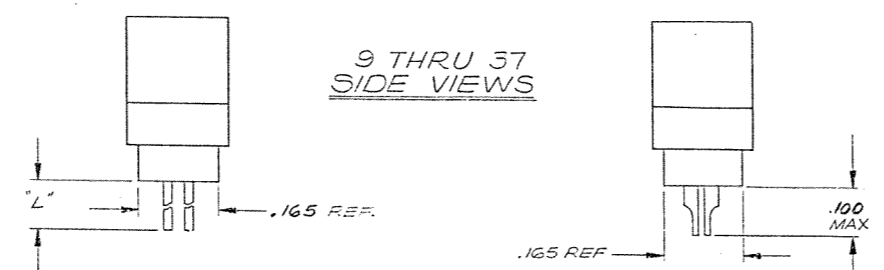
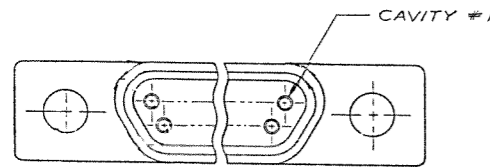

9 THRU 37 CONFIGURATION

3 SOLDER POT-ADAPTER (SHORT)  
3 USED ON 51 ONLY SOLDER POT-ADAPTER (LONG)

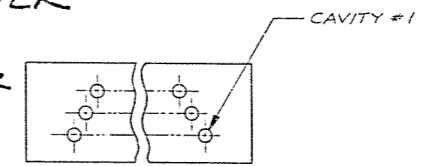

51 CONFIGURATION

(SHOW WITH SOLDER POT TERMINATIONS FOR REFERENCE ONLY. WIRE TERMINATIONS ARE THE SAME CONFIGURATION)

NOTES: UNLESS OTHERWISE SPECIFIED

- 1 MARK "MALCO" OR MALCO LOGO, MILITARY PART NO. (e.g. M53513/07-\*) CODE IDENT. NO. & DATE CODE WITH .041 MIN HIGH CHARACTERS IN APPROXIMATE LOCATION SHOWN.
- 2 EPOXY USING HYSOL # 4215 & 3561.

3 SOLDER POT: MATL: BRASS PER QQ-B-626, COMP 360, 1/2 HARD  
FINISH: COPPER ALLOY/GOLD PLATED  
SKT. CONTACT: MATL: COPPER ALLOY/GOLD PLATED  
HOUSING: MATL: (R3) POLYPHENYLENE SULFIDE RYTON RA-04  
(BR-68) PER MIL-M-24519, COLOR BROWN.

Tyco Customer Drawing 1-1532149-5

QTY REQD	CODE IDENT	PART OR IDENTIFYING NO.	NOMENCLATURE OR DESCRIPTION
PARTS LIST			
UNLESS OTHERWISE SPECIFIED DIMENSIONS ARE IN INCHES TOLERANCES ARE: FRACTIONS DECIMALS ANGLES ± .XX ± ± ± .XXX ± ±		CONTRACT NO.	MALCO A MICRODOT COMPANY, INC. 306 PASADENA AVE., SO. PASADENA, CALIF. 91030
MATERIAL		APPROVALS	DATE
FINISH		CHECKED	1/5/93
NEXT ASSY USED ON		PR. ENG.	7-5-92
APPLICATION		APP'D.	
DO NOT SCALE DRAWING		PROD CODE 824 CODE CD SIZE CODE IDENT NO. DRAWING NO. D 98278 095-0000-0446	
SCALE NONE		SHEET / OF /	

8 7 6 5 4 3 2 1

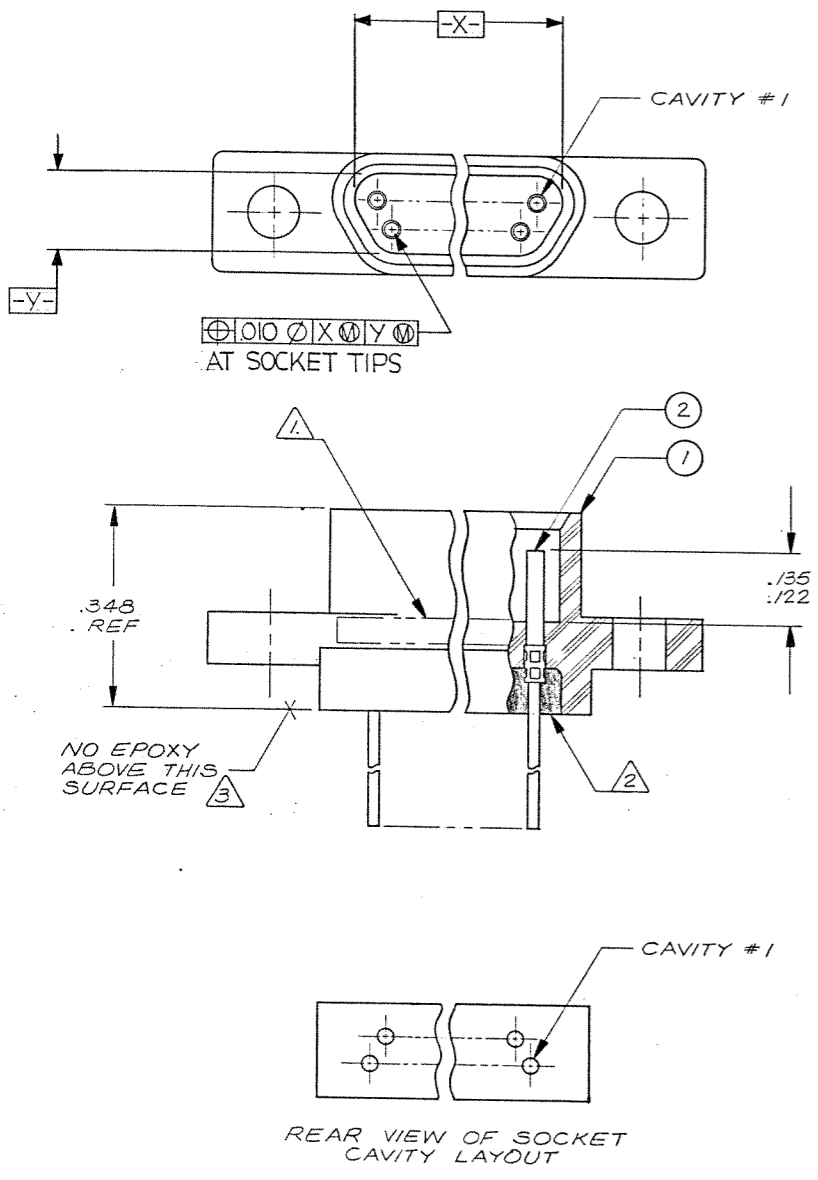

9 THRU 37 CONFIGURATION

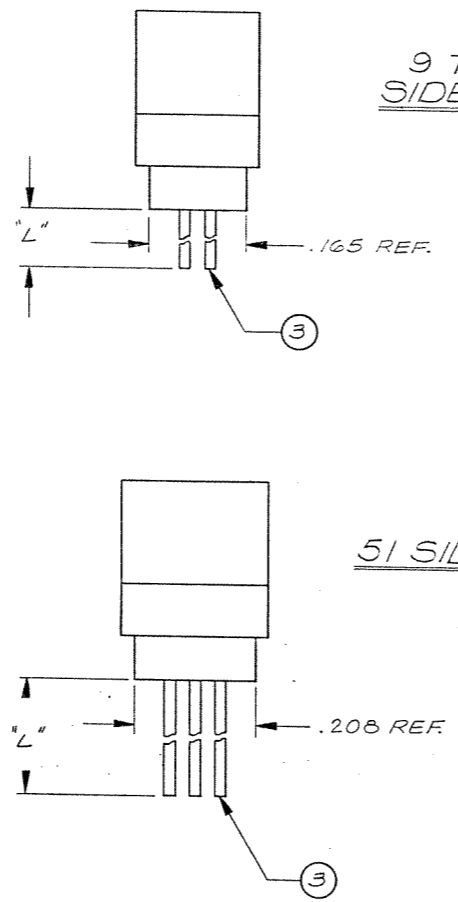

51 CONFIGURATION

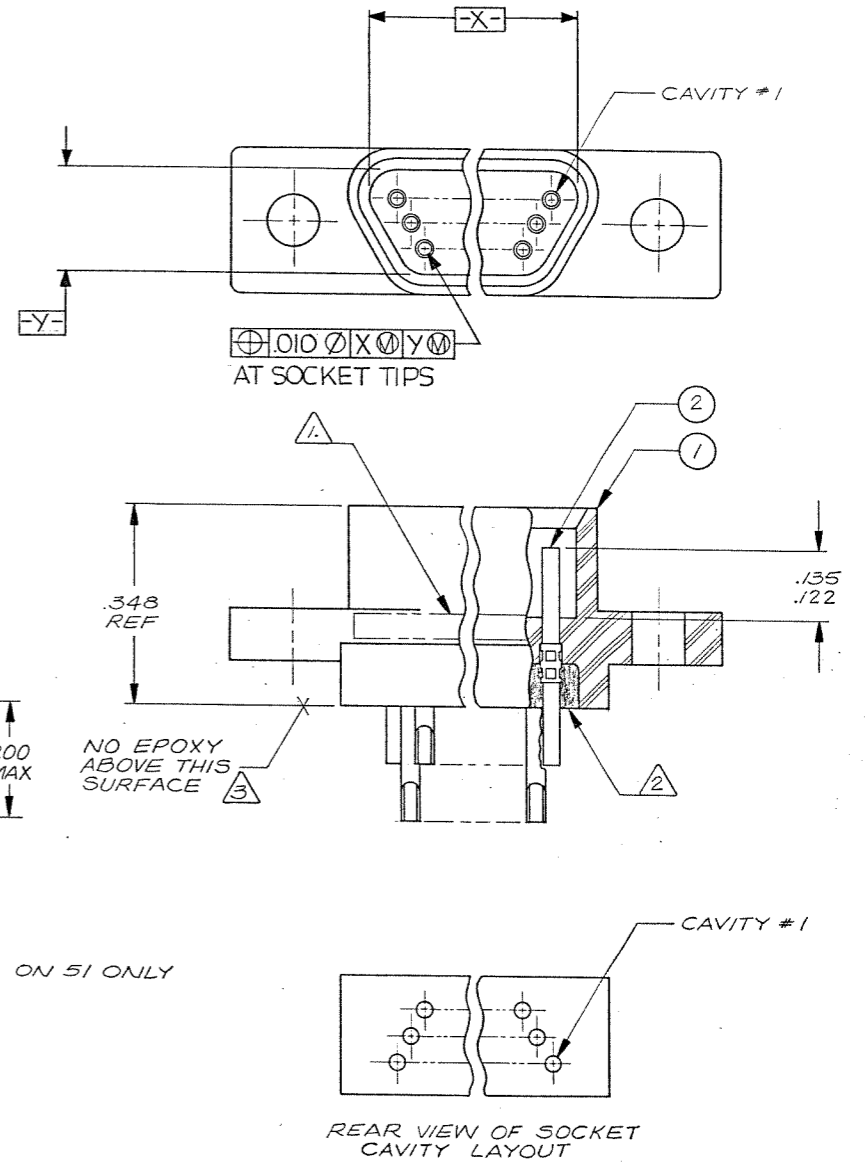
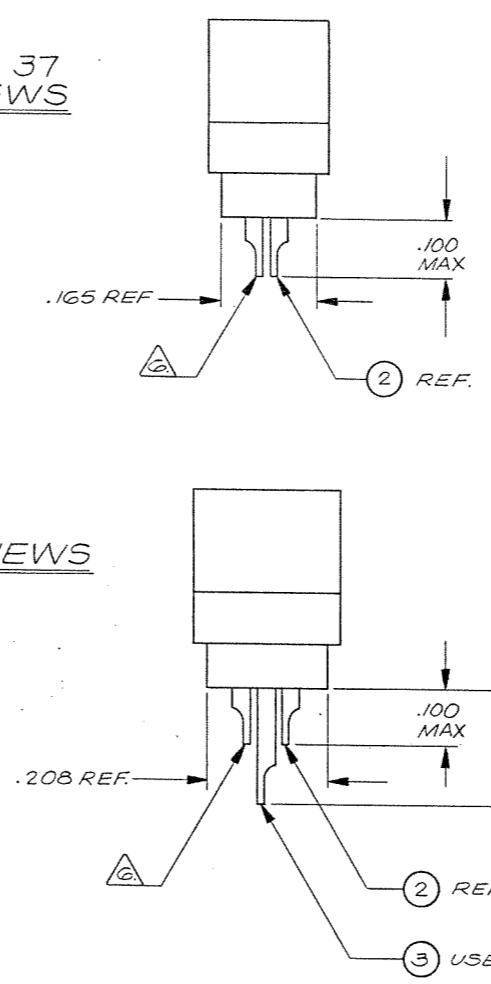

51 CONFIGURATION

NOTES: UNLESS OTHERWISE SPECIFIED

- 1. MARK "MALCO" OR MALCO LOGO, MILITARY PART NO. (e.g. M83513/07-\*), CODE IDENT. NO., & DATE CODE WITH .047 MIN HIGH CHARACTERS IN APPROXIMATE LOCATION SHOWN.
- 2. EPOXY USING HYSOL # 4215 & 3561.
- 3. EPOXY WICKING - UNINSULATED WIRE .050 MAX.  
INSULATED WIRE UP TO # 25 AWG .125 MAX.  
INSULATED WIRE # 24 AWG OR LARGER .200 MAX.
- 4. CRIMP LEADS OR SOLDER POTS INTO CONTACTS PER MEP 302-05.
- 5. NO SCRATCHES SHOWING BASE METAL PERMITTED ON SOLDER POTS.
- 6. CHAMFER ON SOLDER POTS ARE TO BE PARALLEL WITH SIDES OF CONNECTOR WITHIN 10 DEGREES.

Tyco Customer Drawing 1-1532149-5

QTY REQD	CODE IDENT	PART OR IDENTIFYING NO.	NOMENCLATURE OR DESCRIPTION
PARTS LIST			
UNLESS OTHERWISE SPECIFIED DIMENSIONS ARE IN INCHES TOLERANCES ARE:		CONTRACT NO.	
FRACTIONS	DECIMALS	ANGLES	
±	.XX ±	±	
±	.XXX ±		
MATERIAL		APPROVALS	DATE
		DRAWN G. SAUER	5-17-82
		CHECKED G. SAUER	5-18-82
		PR. ENG. W. S. J.	5-18-82
		APPD.	
FINISH		MATERIAL	
		RACK & PANEL CONNECTOR, RCPT. MCD PER MIL-C-83513	
NEXT ASSY USED ON		SIZE	CODE IDENT NO. DRAWING NO.
APPLICATION		D	98278 095-0000-0446
		SCALE	NONE
		SHEET / OF /	

## X-ON Electronics

Largest Supplier of Electrical and Electronic Components

*Click to view similar products for [D-Sub MIL Spec Connectors](#) category:*

*Click to view products by [TE Connectivity](#) manufacturer:*

Other Similar products are found below :

[M85049/50-5F](#) [D38999/24WG11PB-LC](#) [MDM-9SH006A](#) [1218697-4](#) [D38999/26WJ61PC L/C](#) [1484349-1](#) [17D25HV](#) [1996840-1](#) [243082-15](#)  
[1757682-1](#) [17D-E51218-1](#) [17SDA15S](#) [1883533-1](#) [1883886-1](#) [1883889-1](#) [192900-0377](#) [M24308/8-347](#) [M83513/03-E09C](#) [443961-3](#) [5-](#)  
[1218949-1](#) [550-031NF1R6K](#) [3-1236089-2](#) [550E001NF1R3J0L](#) [550T001NF1R6K0L](#) [557T283NF5B08](#) [DB121073-56](#) [DC121073157](#)  
[443869-3](#) [443869-4](#) [443869-5](#) [550S004NF1R1B0F03](#) [557E283NF1A06](#) [527-019NF0303R2K1F](#) [5-446405-1](#) [550-031NF1R2E](#)  
[550E003M2R9J0F04](#) [550E003M3R9J0F05](#) [550E024M104R9J0](#) [550E024NF102R3J0B](#) [550E039NF1R3J1-02](#) [550S003M3R9B0F05](#)  
[550S004M4R7M0F04](#) [550S004NF1R1B1F02](#) [550S008M3F0K0F04](#) [550S086M5R3J0L](#) [550S100NF3F0E](#) [550T001M2R7E0L](#)  
[550T001NF1F0B1L](#) [550T001NF1R1K0G](#) [550T001NF1R3K0G](#)