

Table of Contents

Section 1 – FCA Family

FCA-125 Series	25 Amp, SPDT	4-7
FCA-210 Series	10 Amp, DPDT	8-11
FCA-212 Series	12 Amp, DPDT	12-15
FCA-325 Series	25 Amp, 3PDT	16-19
FCAC-325 Series	25 Amp, 3PST-NO with Aux. Switch.....	20-23
FCA-410 Series	10 Amp, 4PDT	24-27
FCA-610 Series	10 Amp, 6PDT	28-31
Notes Page		32

Section 2 – FCB Family

FCB-205 Series	5 Amp, DPDT	34-37
FCB-310 Series	10 Amp, 3PDT	38-41
FCB-405 Series	5 Amp, 4PDT	42-45
Notes Page		46

Section 3 – Cross Reference Guide, Suggested Practices & Global Contacts

Current Mil-Spec to Tyco Part Number Cross Reference Guide	48-50
Superceded Mil-Spec to Current Mil-Spec to Tyco Part Number Cross Reference Guide	51-56
Selection & Application Guide	57
Notes Page	58
Global Contacts	59

Disclaimer

While Tyco Electronics has made every reasonable effort to ensure the accuracy of the information in this catalog, Tyco Electronics does not guarantee that it is error-free, nor does Tyco Electronics make any other representation, warranty or guarantee that the information is accurate, correct, reliable or current. Tyco Electronics reserves the right to make any adjustments to the information contained herein at any time without notice. Tyco Electronics expressly disclaims all implied warranties (and express warranties, except as otherwise stated in this catalog) regarding the information contained herein, including but not limited to any implied warranties or merchantability or fitness for a particular purpose. It is recommended that you test any new or replacement product before incorporating into a system.

The dimensions in this catalog are for reference purposes only and are subject to change without notice.

Dimensions are in inches over (millimeters), unless otherwise specified.

Specifications are subject to change without notice.

Consult Tyco Electronics at 1-800-522-6752 for latest dimensions and design specifications, or use the global contact list.

TYCO is a trademark. Other products, logos and company names mentioned herein may be trademarks of their respective owners.

© 2003 by Tyco Electronics Corporation
All Rights Reserved.



Mid-Range Military/Aerospace Relays

Section 1

FCA Relay Family



Tyco Electronics Mid-Range Military/Aerospace Relays

25 AMPERES, SPDT



- HERMETICALLY SEALED
- ALL WELDED CONSTRUCTION
- BALANCED FORCE
- PERMANENT MAGNET DRIVE
- CONTACTS: SILVER CADMIUM OXIDE WITH GOLD PLATING
- COILS FOR DC, 50 TO 400Hz AND 400Hz AC
- WEIGHT 1.6 OUNCES MAX. (45.4 GRAMS)

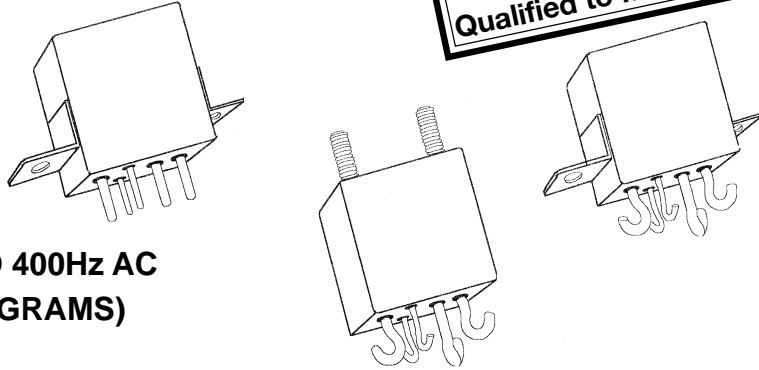

* Meets new spec MIL-PRF-83536/36 and MIL-PRF-83536/37

The Series FCA-125 relay is a polarized single-side stable design, where the flux from a permanent magnet provides the armature holding force in the deactivated state, and its flux path is switched and combined with the coil flux in the operated state. This results in appreciably increased contact pressure in both states over that of a spring return nonpolar design. We also manufacture other versions of this relay:

FCA-325: 25 AMPERE 3PDT RELAY

FCAC-325: 25 AMPERE 3PST RELAY WITH 2 AMPERE, SPDT AUXILIARY CONTACTS

CONTACT RATING-AMPERES

Ratings Are Continuous Duty

TYPE OF LOAD	LIFE (MIN.) CYCLES X 10 ³	28 VDC	115VAC 400Hz	115VAC 60Hz *
Resistive	50	25	25	10
Inductive	10	12	—	10
Inductive	20	—	15	—
Motor	50	10	10	8
Lamp	50	5	5	—
* 60 Hz LOADS RATED FOR 10,000 OPERATIONS				

OVERLOAD CURRENT 50 AMPS DC, 80AMPS 400Hz
 RUPTURE CURRENT 60 AMPS DC, 100 AMPS 400Hz
 CONTACT MAKE BOUNCE 1 MILLISECOND AT NOMINAL VOLTAGE
 MAX. CONTACT DROP AT 25 AMPS: INITIAL 0.150 VOLTS.
 END OF LIFE 0.175 VOLTS



Tyco Electronics Mid-Range Military/Aerospace Relays

25 AMPERES, SPDT

COIL DATA

COIL CODE	NOMINAL VOLTAGES	FREQ. Hz	DC RES. AC AMPS (B)	OVER TEMPERATURE RANGE		
				PICKUP OR BELOW VOLTS	DROPOUT OR ABOVE VOLTS	MUST HOLD VOLTAGE (C)
1	6	DC	20 Ω	4.5	0.3	2.5
2	12	DC	80 Ω	9.0	0.75	4.5
3	28	DC	320 Ω	18.0	1.5	7.0
4 (A)	28	DC	320 Ω	18.0	1.5	7.0
5	48	DC	920 Ω	32.0	2.5	14.0
6	28	400Hz	180 mA	22.0	1.25	10.0
7	28	50/400Hz	100 mA	22.0	1.25	10.0
8	115	400 Hz	40 mA	90.0	5.0	40.0
9	115	50/400Hz	30 mA	95.0	5.0	40.0

- A. CODE 4 COILS HAVE BACK EMF SUPPRESSION TO 42 VOLTS MAX.
- B. DC COIL RESISTANCE $\pm 10\%$ AT 25°C; AC COIL MAX. CURRENT AT NOMINAL VOLTAGE.
- C. RELAY WILL STAY IN PICKED-UP STATE DOWN TO MUST HOLD VOLTAGES SHOWN.
- D. MAX. OVERVOLTAGE: 6 & 12 VDC COILS 120% OF NOMINAL; ALL OTHERS 110% OF NOMINAL.
- E. COILS AVAILABLE FOR OTHER VOLTAGES AND FOR AC 50/60HZ.
- NOTE: Only DC Coil Models are QPL Approved.

GENERAL SPECIFICATIONS

TEMPERATURE RATING:		-70°C TO + 125°C
ALTITUDE:		300,000 FEET
SHOCK:*	Z, Y, & X ENCLOSURES	200 g FOR 6 mS
	W & M ENCLOSURES (STUD MTG.)	100 g FOR 6 mS
VIBRATION, SINUSOIDAL:*	Z, Y, & X ENCLOSURES	30 g 33-3000Hz
	W & M ENCLOSURES (STUD MTG.)	20 g 33-3000Hz
VIBRATION, RANDOM: *	Z, Y, & X ENCLOSURES	0.4 g ² /Hz 50-2000Hz
	W & M ENCLOSURES (STUD MTG.)	0.2 g ² /Hz 50-2000Hz
DIELECTRIC STRENGTH AT SEA LEVEL:	ALL CIRCUITS TO GROUND AND CIRCUIT TO CIRCUIT.	1250 V rms
	COIL TO GROUND	1000 V rms
DIELECTRIC STRENGTH AT 80,000 FEET:		350 V rms
INSULATION RESISTANCE:	INITIAL (500 VDC)	100 MΩ MINIMUM
	AFTER LIFE OR ENVIRONMENTAL TESTS	50 MΩ MINIMUM
OPERATE TIME AT NOMINAL VOLTAGE:	DC RELAYS	10 ms OR LESS
	AC RELAYS	15 ms OR LESS
RELEASE TIME AT NOMINAL VOLTAGE:	DC RELAYS	10 ms OR LESS
	AC RELAYS	50 ms OR LESS

* Max. contact opening under vibration or shock 10 microseconds



Tyco Electronics Mid-Range Military/Aerospace Relays

25 AMPERES, SPDT

Below are shown the standard terminal types and the enclosures available. Specify the assembly as indicated under How To Order. Dimensions are shown in inches $\pm .010$ and (Millimeters $\pm .25$).

TERMINALS

CODE

"A"

Socket Pins - All DC Coils
PIN TERMINALS ARE GOLD PLATED

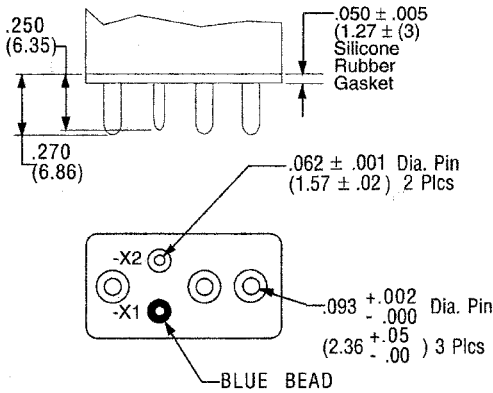

CODE

"B"

Solder Pin Terminals
PIN TERMINALS TIN/LEAD PLATED

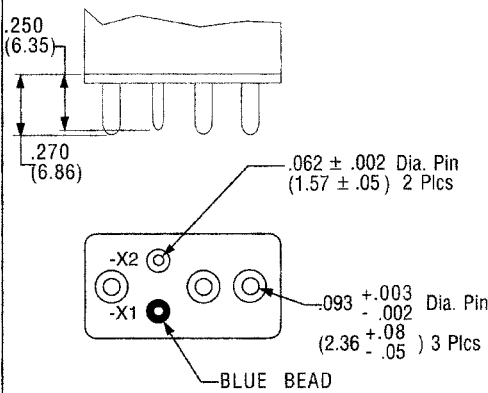

CODE

"C"

Solder Hook Terminals
HOOK TERMINALS TIN/LEAD PLATED

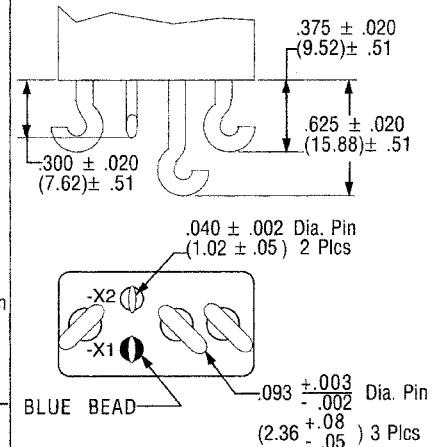

CODE

"D"

Socket Pins - All AC Coils
PIN TERMINALS ARE GOLD PLATED

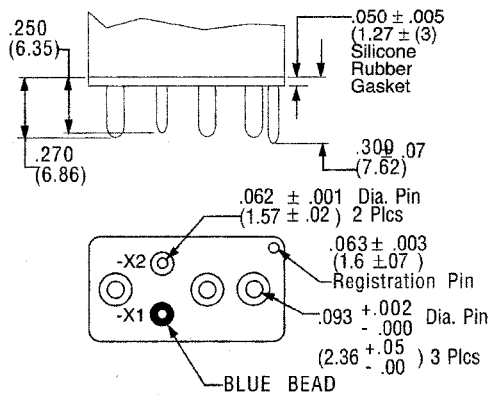

ENCLOSURES

All Enclosures have cupro-Nickel cans bright acid tin/lead plated after assembly to terminal headers.

Dimensions: Inches $\pm .010$ (mm $\pm .25$)

"A" - AC Coils 1.125 in. (31.91) Max
DC Coils 1.010 in. (28.65) Max..

CODE

"Z"

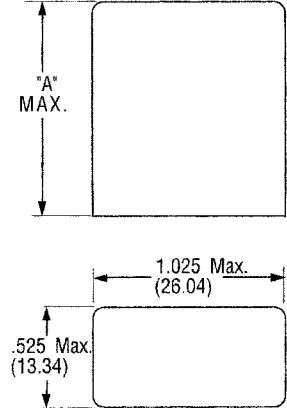

CODE

"Y"

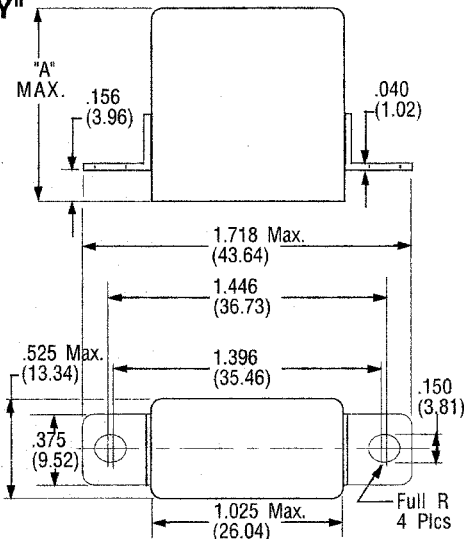

CODE

"X"

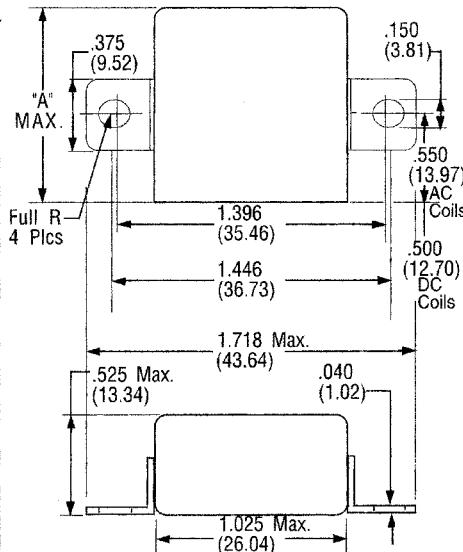

CODE

"W"

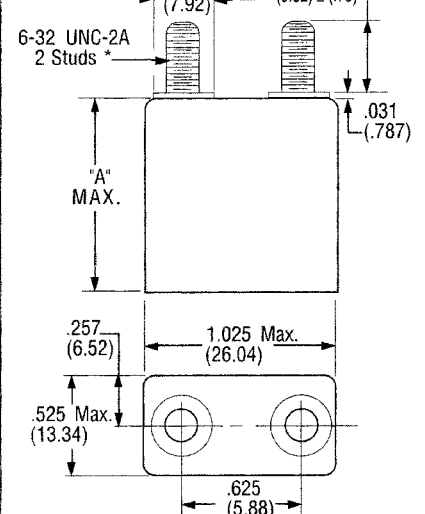

*Metric threads available.
To specify use \square in place of \square



Tyco Electronics Mid-Range Military/Aerospace Relays

25 AMPERES, SPDT

TERMINAL WIRING

DC COILS

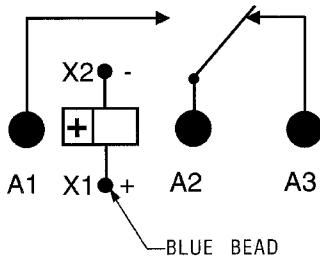

DC COILS WITH
TRANSIENT SUPPRESSION

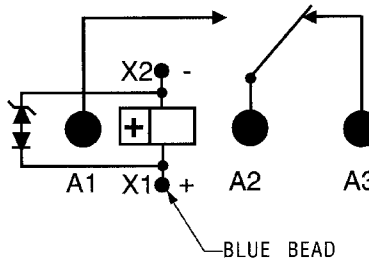

AC COILS

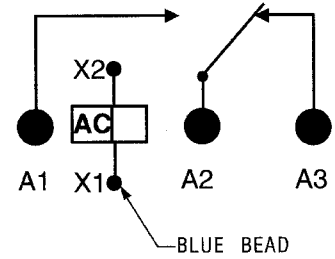

NOTE: Polarity must be observed with DC coil supply. Relay is polarized with a permanent magnet and will not operate or be damaged by reverse polarity.

Diodes used in transient suppression and in AC rectifier circuits have peak inverse voltage rating of 600 VDC minimum. Zener diodes have a minimum rating of 1 watt.

Terminal designations are for reference only and do not appear on the header.

TERMINAL LAYOUT

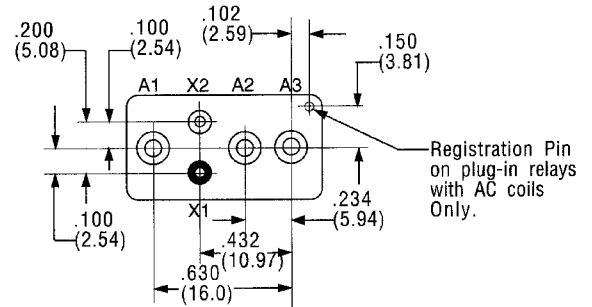

HOW TO ORDER

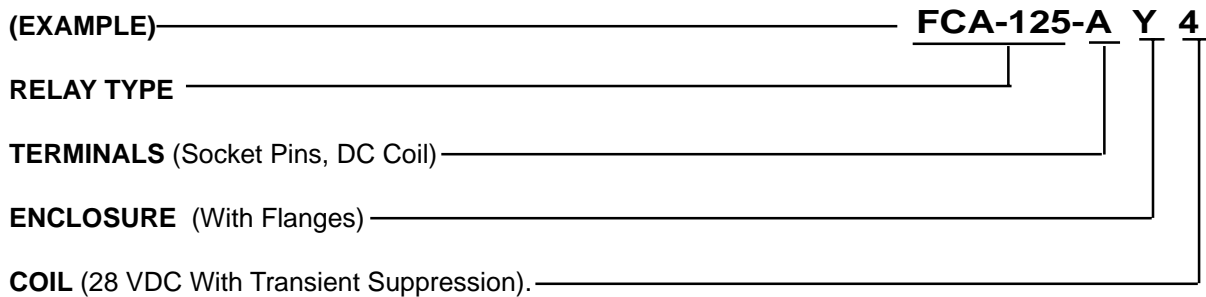

NOTE: Only DC coil models are QPL Approved



Tyco Electronics Mid-Range Military/Aerospace Relays

10 AMPERES, DPDT



- HERMETICALLY SEALED
- ALL WELDED CONSTRUCTION
- BALANCED FORCE
- PERMANENT MAGNET DRIVE
- CONTACTS: SILVER CADMIUM OXIDE WITH GOLD PLATING
- COILS FOR DC, 50 TO 400Hz AND 400Hz AC
- WEIGHT 1.6 OUNCES MAX. (45.4 GRAMS)

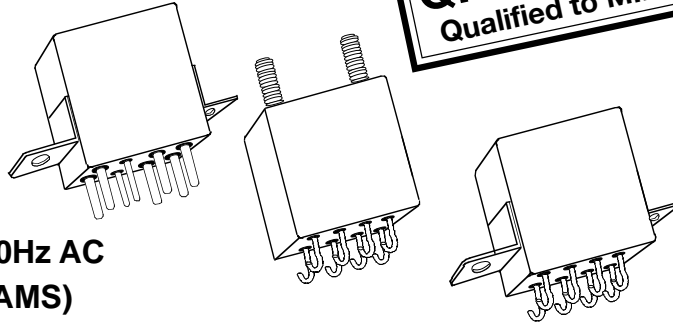

The Series FCA-210 relay is a polarized single-side stable design, where the flux from a permanent magnet provides the armature holding force in the deactivated state, and its flux path is switched and combined with the coil flux in the operated state. This results in appreciably increased contact pressure in both states over that of a spring return nonpolar design. We also manufacture other versions of this relay:

- FCA-410:** 10 AMPERE 4PDT RELAY
- FCA-610:** 10 AMPERE 6 PDT RELAY

AVAILABLE

FCA-215: 15 AMPERE DPDT RELAY, HAS THE SAME SPECIFICATIONS AS THE FCA-210 EXCEPT IS RATED AT 15 AMPS.

CONTACT RATING-AMPERES

Ratings Are Continuous Duty

TYPE OF LOAD	LIFE (MIN.) CYCLES X 10 ³	28 VDC	115VAC 400Hz	115/200VAC 3Ø	
				400 Hz	60Hz *
Resistive	100	10	10	10	2.5
Inductive	20	8	8	8	2.5
Motor	100	4	4	4	2.0
Lamp	100	2	2	2	1
* 60 Hz LOADS RATED FOR 10,000 OPERATIONS					

OVERLOAD CURRENT 40 AMPS DC, 60AMPS 400Hz
 RUPTURE CURRENT 50 AMPS DC, 80 AMPS 400Hz
 CONTACT MAKE BOUNCE 1 MILLISECOND AT NOMINAL VOLTAGE
 MAX. CONTACT DROP AT 10 AMPS: INITIAL 0.100 VOLTS.
 END OF LIFE 0.125 VOLTS



Tyco Electronics Mid-Range Military/Aerospace Relays

10 AMPERES, DPDT

COIL DATA

COIL CODE	NOMINAL VOLTAGES	FREQ. Hz	DC RES. AC AMPS (B)	OVER TEMPERATURE RANGE		
				PICKUP OR BELOW VOLTS	DROPOUT OR ABOVE VOLTS	MUST HOLD VOLTAGE (C)
1	6	DC	20 Ω	4.5	0.3	2.5
2	12	DC	80 Ω	9.0	0.75	4.5
3	28	DC	320 Ω	18.0	1.5	7.0
4 (A)	28	DC	320 Ω	18.0	1.5	7.0
5	48	DC	920 Ω	32.0	2.5	14.0
6	28	400Hz	180 mA	22.0	1.25	10.0
7	28	50/400Hz	100 mA	22.0	1.25	10.0
8	115	400 Hz	40 mA	90.0	5.0	40.0
9	115	50/400Hz	30 mA	95.0	5.0	40.0

- A. CODE 4 COILS HAVE BACK EMF SUPPRESSION TO 42 VOLTS MAX.
- B. DC COIL RESISTANCE $\pm 10\%$ AT 25°C; AC COIL MAX. CURRENT AT NOMINAL VOLTAGE.
- C. RELAY WILL STAY IN PICKED-UP STATE DOWN TO MUST HOLD VOLTAGES SHOWN.
- D. MAX. OVERVOLTAGE: 6 & 12 VDC COILS 120% OF NOMINAL; ALL OTHERS 110% OF NOMINAL.
- E. COILS AVAILABLE FOR OTHER VOLTAGES AND FOR AC 50/60HZ.
- NOTE: Only DC Coil Models are QPL Approved.

GENERAL SPECIFICATIONS

TEMPERATURE RATING:		-70°C TO + 125°C
ALTITUDE:		300,000 FEET
SHOCK:*	Z, Y, & X ENCLOSURES	200 g FOR 6 mS
	W & M ENCLOSURES (STUD MTG.)	100 g FOR 6 mS
VIBRATION, SINUSOIDAL:*	Z, Y, & X ENCLOSURES	30 g 33-3000Hz
	W & M ENCLOSURES (STUD MTG.)	20 g 33-3000Hz
VIBRATION, RANDOM: *	Z, Y, & X ENCLOSURES	0.4 g ² /Hz 50-2000Hz
	W & M ENCLOSURES (STUD MTG.)	0.2 g ² /Hz 50-2000Hz
DIELECTRIC STRENGTH AT SEA LEVEL:	ALL CIRCUITS TO GROUND AND CIRCUIT TO CIRCUIT.	1250 V rms
	COIL TO GROUND	1000 V rms
DIELECTRIC STRENGTH AT 80,000 FEET:		350 V rms
INSULATION RESISTANCE:	INITIAL (500 VDC)	100 MΩ MINIMUM
	AFTER LIFE OR ENVIRONMENTAL TESTS	50 MΩ MINIMUM
OPERATE TIME AT NOMINAL VOLTAGE:	DC RELAYS	10 ms OR LESS
	AC RELAYS	15 ms OR LESS
RELEASE TIME AT NOMINAL VOLTAGE:	DC RELAYS	10 ms OR LESS
	AC RELAYS	50 ms OR LESS

* Max. contact opening under vibration or shock 10 microseconds



Tyco Electronics Mid-Range Military/Aerospace Relays

10 AMPERES, DPDT

Below are shown the standard terminal types and the enclosures available. Specify the assembly as indicated under How To Order. Dimensions are shown in inches $\pm .010$ and (Millimeters $\pm .25$).

TERMINALS

SOCKET PINS ARE GOLD PLATED
POLARIZING PINS ARE TIN/LEAD PLATED
CIRCUIT BOARD PINS ARE TIN/LEAD PLATED
DIMENSIONS EXCEPT AS NOTED:
INCHES $\pm .010$ (MILLIMETERS $\pm .25$)

CODE

"A" Socket Pins - All DC Coils

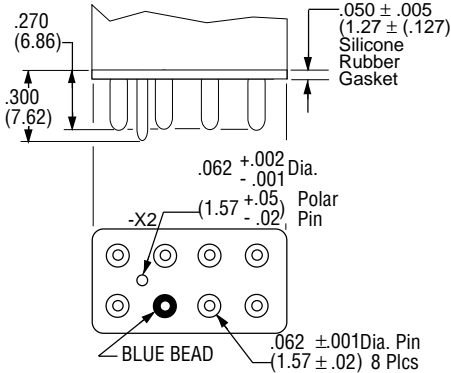

CODE

"B" Circuit Board Pins - All DC Coils

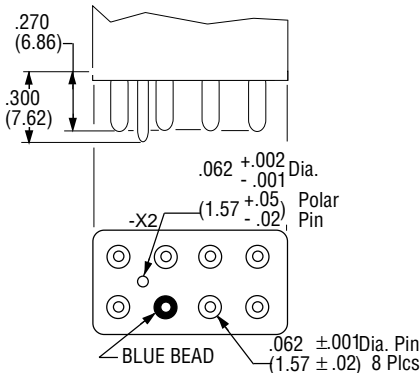

CODE

"C" Solder Hook Terminals

HOOK TERMINALS TIN/LEAD PLATED

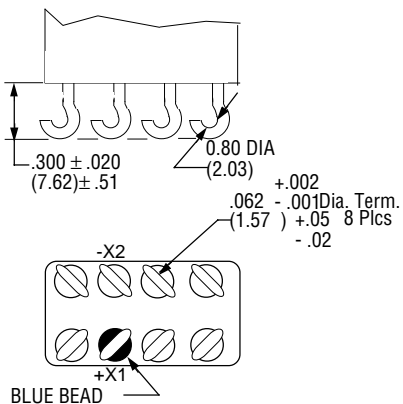

CODE

"D" Socket Pins 115 VAC

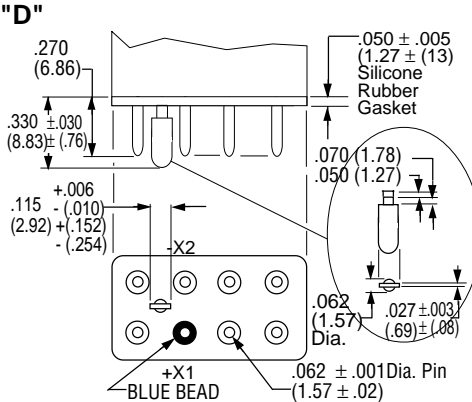

CODE

"E" Socket Pins 28 VAC Coils

Same as Code "D" Except polarizing Pin turned 90° to this plane.

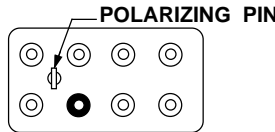

CODE

"F" Circuit Board Pins 115 VAC Coils

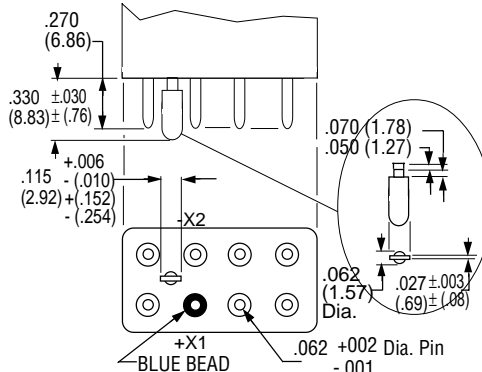

CODE

"F" Circuit Board Pins 28 VAC Coils

Same as Code "D" Except polarizing Pin turned 90° to this plane.

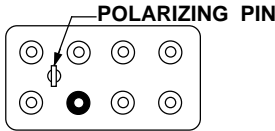

CODE

"H" 90° Solder Pins

All Pins Bright Acid Tin/lead

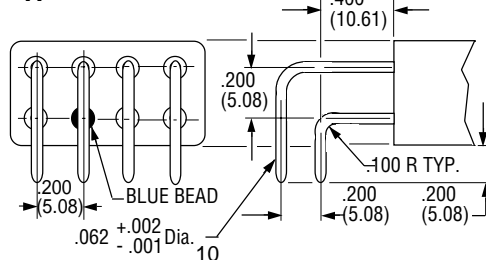

ENCLOSURES

All Enclosures have Cupro-Nickel Cans bright acid tin/lead plated after assembly to terminal headers.

Dimensions: Inches $\pm .010$ (mm $\pm .25$)

"A" AC Coils 1.125 in. (28.57) Max.
DC Coils 1.010 in. (25.65) Max.

CODE

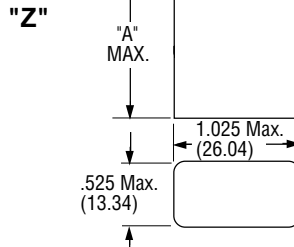

CODE

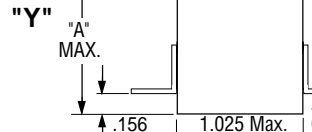

CODE

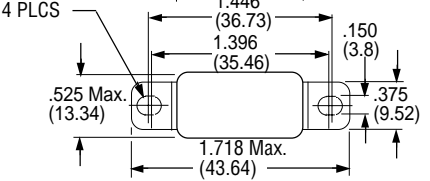

CODE

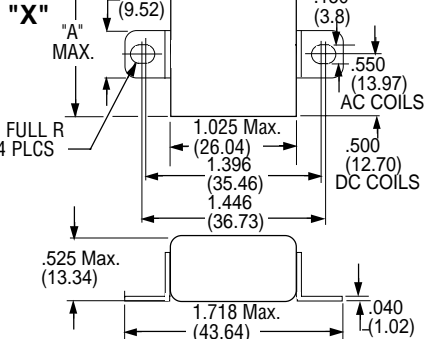

CODE

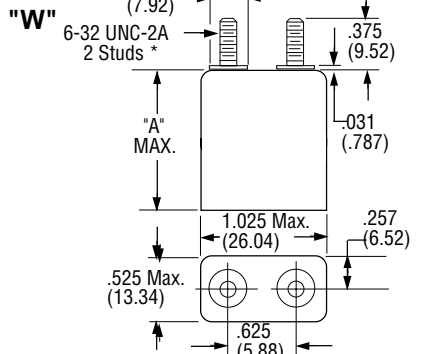

*Metric threads available. To specify use [M] in place of [W]



Tyco Electronics Mid-Range Military/Aerospace Relays

10 AMPERES, DPDT

TERMINAL WIRING

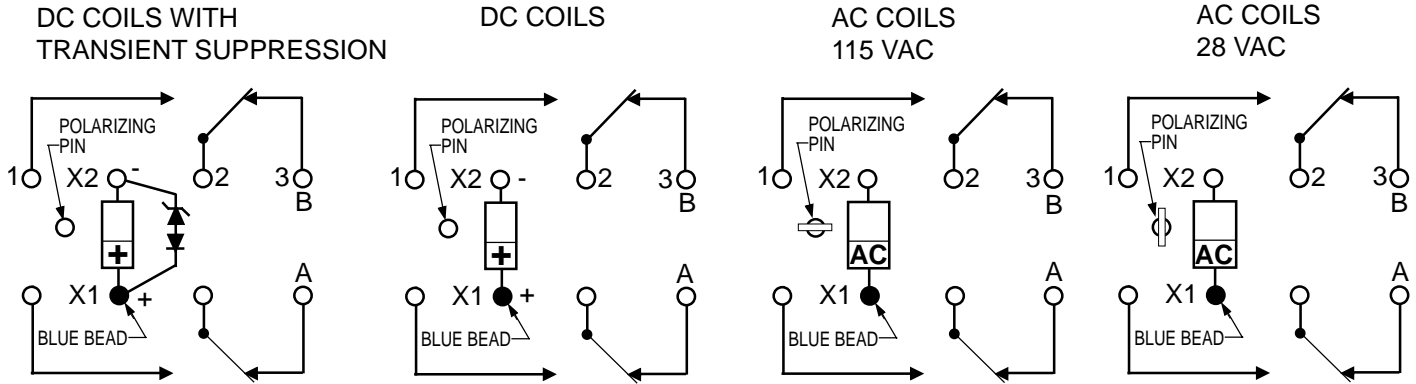

NOTE: Polarity must be observed with DC coil supply. Relay is polarized with a permanent magnet and will not operate or be damaged by reverse polarity.

Diodes used in transient suppression and in AC rectifier circuits have peak inverse voltage rating of 600 VDC minimum. Zener diodes have a minimum rating of 1 watt.

Terminal designations are for reference only and do not appear on the header.

TERMINAL LAYOUT

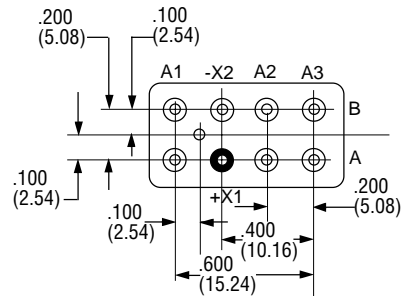

HOW TO ORDER

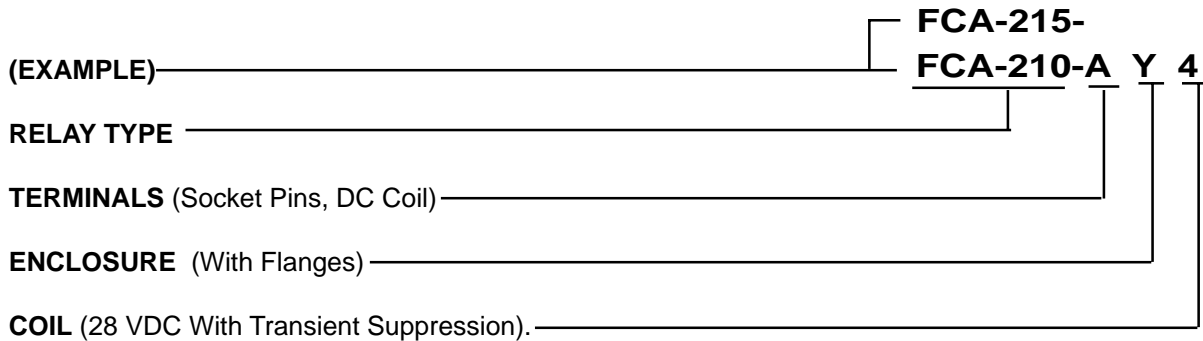

NOTE: Only DC coil models are QPL Approved



Tyco Electronics Mid-Range Military/Aerospace Relays

12 AMPERES, DPDT

- HERMETICALLY SEALED
- ALL WELDED CONSTRUCTION
- BALANCED FORCE
- PERMANENT MAGNET DRIVE
- CONTACTS: SILVER CADMIUM OXIDE WITH GOLD PLATING
- COILS FOR DC, 50 TO 400Hz AND 400Hz AC
- WEIGHT 1.6 OUNCES MAX. (45.4 GRAMS)

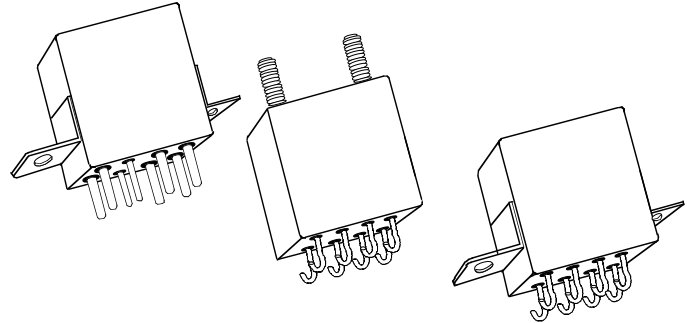

The Series FCA-212 relay is a polarized single-side stable design, where the flux from a permanent magnet provides the armature holding force in the deactivated state, and its flux path is switched and combined with the coil flux in the operated state. This results in appreciably increased contact pressure in both states over that of a spring return nonpolar design. We also manufacture other versions of this relay:

FCA-412: 12 AMP 4PDT RELAY

CONTACT RATING-AMPERES

Ratings Are Continuous Duty

TYPE OF LOAD	LIFE (MIN.) CYCLES X 10 ³	28 VDC	115VAC 400Hz	115/200 VAC 3Ø	
				400Hz	60Hz *
Resistive	100	12	12	12	2.5
Inductive	20	8	8	8	2.5
Motor	100	4	4	4	2.0
Lamp	100	2	2	2	1
* 60 Hz LOADS RATED FOR 10,000 OPERATIONS					

OVERLOAD CURRENT 40 AMPS DC, 60AMPS 400Hz
 RUPTURE CURRENT 50 AMPS DC, 80 AMPS 400Hz
 CONTACT MAKE BOUNCE 1 MILLISECOND AT NOMINAL VOLTAGE
 MAX. CONTACT DROP AT 12 AMPS: INITIAL 0.150 VOLTS.
 END OF LIFE 0.175 VOLTS



Tyco Electronics Mid-Range Military/Aerospace Relays

12 AMPERES, DPDT

COIL DATA

COIL CODE	NOMINAL VOLTAGES	FREQ. Hz	DC RES. AC AMPS (B)	OVER TEMPERATURE RANGE		
				PICKUP OR BELOW VOLTS	DROPOUT OR ABOVE VOLTS	MUST HOLD VOLTAGE (C)
1	6	DC	20 Ω	4.5	0.3	2.5
2	12	DC	80 Ω	9.0	0.75	4.5
3	28	DC	320 Ω	18.0	1.5	7.0
4 (A)	28	DC	320 Ω	18.0	1.5	7.0
5	48	DC	920 Ω	32.0	2.5	14.0
6	28	400Hz	180 mA	22.0	1.25	10.0
7	28	50/400Hz	100 mA	22.0	1.25	10.0
8	115	400 Hz	40 mA	90.0	5.0	40.0
9	115	50/400Hz	30 mA	95.0	5.0	40.0

- A. CODE 4 COILS HAVE BACK EMF SUPPRESSION TO 42 VOLTS MAX.
- B. DC COIL RESISTANCE ± 10% AT 25°C; AC COIL MAX. CURRENT AT NOMINAL VOLTAGE.
- C. RELAY WILL STAY IN PICKED-UP STATE DOWN TO MUST HOLD VOLTAGES SHOWN.
- D. MAX. OVERVOLTAGE: 6 & 12 VDC COILS 120% OF NOMINAL; ALL OTHERS 110% OF NOMINAL.
- E. COILS AVAILABLE FOR OTHER VOLTAGES AND FOR AC 50/60HZ.

GENERAL SPECIFICATIONS

TEMPERATURE RATING:		-70°C TO + 125°C
ALTITUDE:		300,000 FEET
SHOCK:*	Z, Y, & X ENCLOSURES	200 g FOR 6 mS
	W & M ENCLOSURES (STUD MTG.)	100 g FOR 6 mS
VIBRATION, SINUSOIDAL:*	Z, Y, & X ENCLOSURES	30 g 33-3000Hz
	W ENCLOSURE	20 g 33-3000Hz
VIBRATION, RANDOM: *	Z, Y, & X ENCLOSURES	0.4 g ² /Hz 50-2000Hz
	W & M ENCLOSURES (STUD MTG.)	0.2 g ² /Hz 50-2000Hz
DIELECTRIC STRENGTH AT SEA LEVEL:	ALL CIRCUITS TO GROUND AND CIRCUIT TO CIRCUIT.	1250 V rms
	COIL TO GROUND	1000 V rms
DIELECTRIC STRENGTH AT 80,000 FEET:		350 V rms
INSULATION RESISTANCE:	INITIAL (500 VDC)	100 MΩ MINIMUM
	AFTER LIFE OR ENVIRONMENTAL TESTS	50 MΩ MINIMUM
OPERATE TIME AT NOMINAL VOLTAGE:	DC RELAYS	10 ms OR LESS
	AC RELAYS	15 ms OR LESS
RELEASE TIME AT NOMINAL VOLTAGE:	DC RELAYS	10 ms OR LESS
	AC RELAYS	50 ms OR LESS

* Max. contact opening under vibration or shock 10 microseconds



Tyco Electronics Mid-Range Military/Aerospace Relays

12 AMPERES, DPDT

Below are shown the standard terminal types and the enclosures available. Specify the assembly as indicated under How To Order. Dimensions are shown in inches $\pm .010$ and (Millimeters $\pm .25$).

TERMINALS

SOCKET PINS ARE GOLD PLATED
POLARIZING PINS ARE TIN/LEAD PLATED.
CIRCUIT BOARD PINS ARE TIN/LEAD PLATED.
DIMENSIONS EXCEPT AS NOTED:
INCHES $\pm .010$ (MILLIMETERS $\pm .25$)

CODE

"A" Socket Pins - All DC Coils

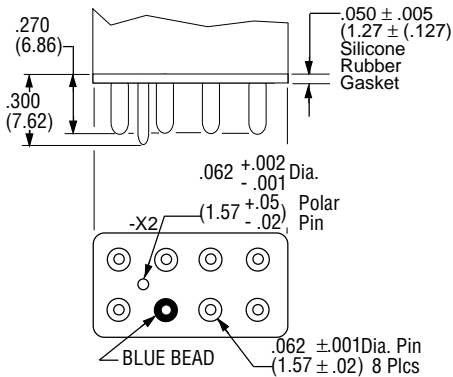

CODE

"B" Circuit Board Pins - All DC Coils

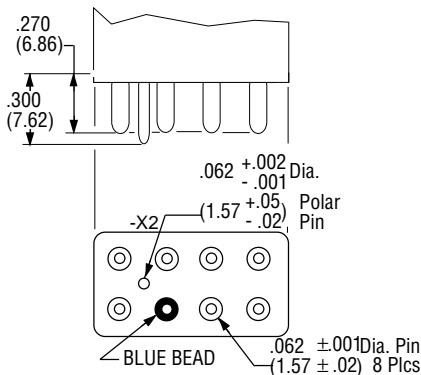

CODE

"C" Solder Hook Terminals

HOOK TERMINALS TIN/lead PLATED

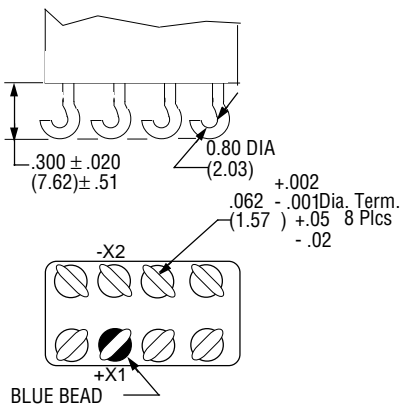

CODE

"D" Socket Pins 115 VAC

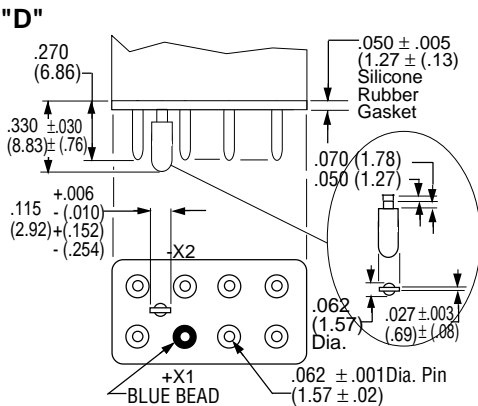

CODE

"E" Socket Pins 28 VAC Coils

Same as Code "D" Except polarizing Pin turned 90° to this plane.

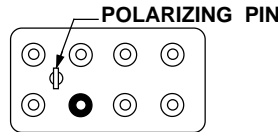

CODE

"F" Circuit Board Pins 115 VAC Coils

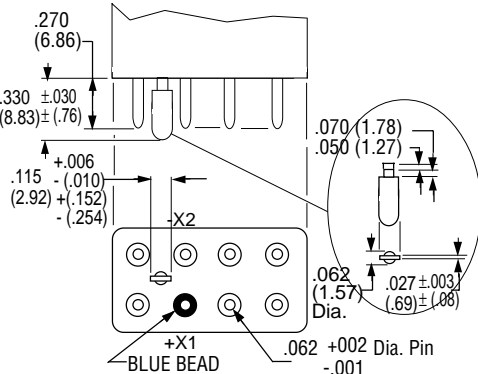

CODE

"F" Circuit Board Pins 28 VAC Coils

Same as Code "D" Except polarizing Pin turned 90° to this plane.

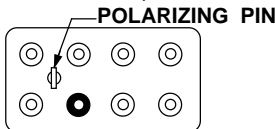

CODE

"H" 90° Solder Pins

All Pins Bright Acid Tin/lead

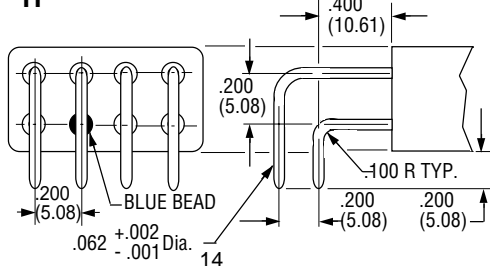

ENCLOSURES

All Enclosures have Cupro-Nickel Cans bright acid tin/lead plated after assembly to terminal headers.

Dimensions: Inches $\pm .010$ (mm $\pm .25$)

"A" AC Coils 1.125 in. (28.57) Max.
DC Coils 1.010 in. (25.65) Max.

CODE

"Z"

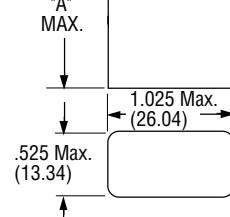

CODE

"Y"

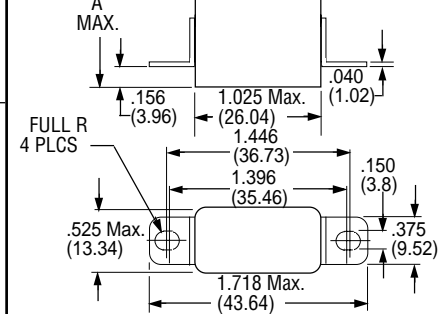

CODE

"X"

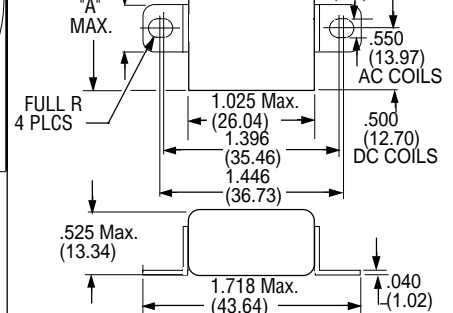

CODE

"W"

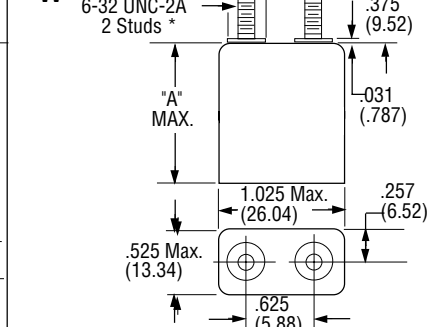

*Metric threads available, To specify use \square in place of W



Tyco Electronics Mid-Range Military/Aerospace Relays

12 AMPERES, DPDT

TERMINAL WIRING

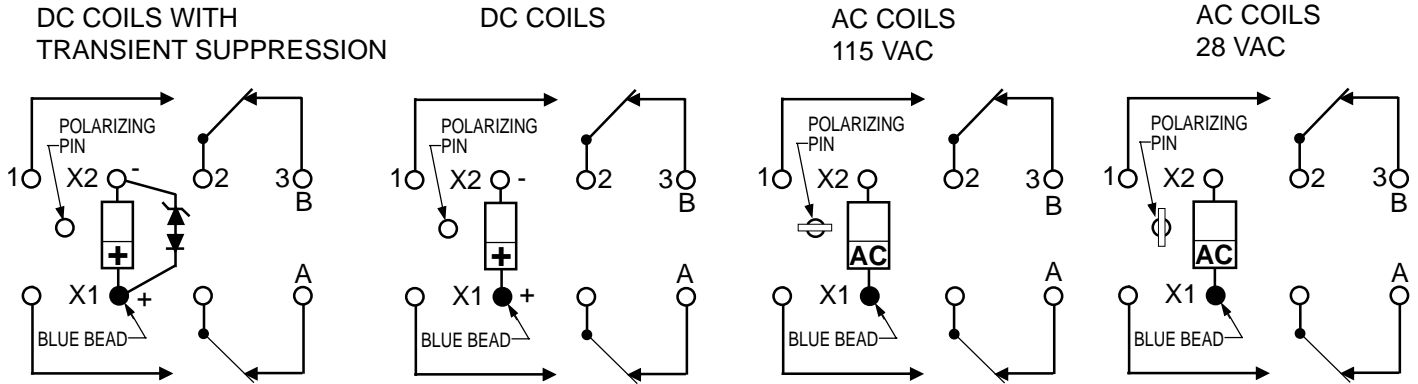

NOTE: Polarity must be observed with DC coil supply. Relay is polarized with a permanent magnet and will not operate or be damaged by reverse polarity.

Diodes used in transient suppression and in AC rectifier circuits have peak inverse voltage rating of 600 VDC minimum. Zener diodes have a minimum rating of 1 watt.

Terminal designations are for reference only and do not appear on the header.

TERMINAL LAYOUT

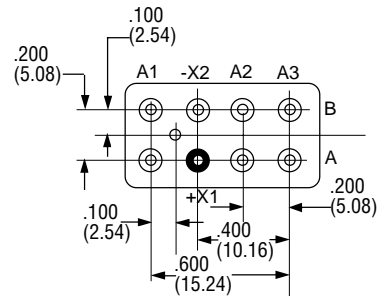

HOW TO ORDER

(EXAMPLE) _____ **FCA-212-A Y 4**

RELAY TYPE _____

TERMINALS (Socket Pins, DC Coil) _____

ENCLOSURE (With Flanges) _____

COIL (28 VDC With Transient Suppression). _____



Tyco Electronics Mid-Range Military/Aerospace Relays

25 AMPERES, 3PDT

- HERMETICALLY SEALED
- ALL WELDED CONSTRUCTION
- BALANCED FORCE
- PERMANENT MAGNET DRIVE
- CONTACTS: SILVER CADMIUM OXIDE WITH GOLD PLATING
- COILS FOR DC, 50 TO 400Hz AND 400Hz AC
- WEIGHT 2.89 OUNCES MAX. (82 GRAMS)

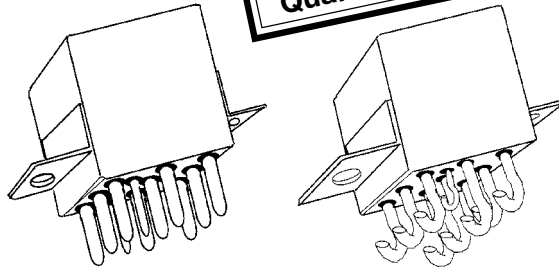

The Series FCA-325 relay is a polarized single-side stable design, where the flux from a permanent magnet provides the armature holding force in the deactivated state, and its flux path is switched and combined with the coil flux in the operated state. This results in appreciably increased contact pressure in both states over that of a spring return nonpolar design. We also manufacture other versions of this relay:

FCA-125: 25 AMP SPDT RELAY

FCAC-325: 25 AMP 3PST RELAY WITH 2 AMP SPDT AUXILIARY CONTACTS

CONTACT RATING-AMPERES

Ratings Are Continuous Duty

TYPE OF LOAD	LIFE (MIN.) CYCLES X 10 ³	28 VDC	115VAC 400HZ	115/200VAC 400Hz-3Ø	115/200VAC 60Hz-3Ø *
Resistive	50	25	25	25	2.5
Inductive	10	12	-	-	2.5
Inductive	20	-	15	15	-
Motor	50	10	10	10	2.0
Lamp	50	5	5	5	1.0
* 60 Hz LOADS RATED FOR 10,000 OPERATIONS					

OVERLOAD CURRENT 50 AMPS DC, 80 AMPS 400HZ
 RUPTURE CURRENT 60 AMPS DC, 100 AMPS 400HZ
 CONTACT MAKE BOUNCE 1 MILLISECOND AT NOMINAL VOLTAGE
 MAX. CONTACT DROP AT 25 AMPS: INITIAL 0.150 VOLTS.
 END OF LIFE 0.175 VOLTS



Tyco Electronics Mid-Range Military/Aerospace Relays

25 AMPERES, 3PDT

COIL DATA

COIL CODE	NOMINAL VOLTAGES	FREQ. HZ	DC RES. AC AMPS (B)	OVER TEMPERATURE RANGE		
				PICKUP OR BELOW VOLTS	DROPOUT OR ABOVE VOLTS	MUST HOLD VOLTAGE (C)
1	6	DC	18 Ω	4.5	0.3	2.5
2	12	DC	70 Ω	9.0	0.75	4.5
3	28	DC	290 Ω	18.0	1.5	7.0
4 (A)	28	DC	290 Ω	18.0	1.5	7.0
5	48	DC	865 Ω	32.0	2.5	14.0
6	28	400HZ	225 mA	22.0	1.25	10.0
7	28	50/400Hz	120 mA	22.0	1.25	10.0
8	115	400 Hz	40 mA	90.0	5.0	40.0
9	115	50/400Hz	30 mA	95.0	5.0	40.0

- A. CODE 4 COILS HAVE BACK EMF SUPPRESSION TO 42 VOLTS MAX.
 B. DC COIL RESISTANCE $\pm 10\%$ AT 25°C; AC COIL MAX. CURRENT AT NOMINAL VOLTAGE.
 C. RELAY WILL STAY IN PICKED-UP STATE DOWN TO MUST HOLD VOLTAGES SHOWN.
 D. MAX. OVER-VOLTAGE: 6 & 12 VDC COILS 120% OF NOMINAL; ALL OTHERS 110% OF NOMINAL.
 E. COILS AVAILABLE FOR OTHER VOLTAGES AND FOR AC 50/60HZ.
 NOTE: Only DC Coil Models are QPL Approved.

GENERAL SPECIFICATIONS

TEMPERATURE RATING:		-70°C TO + 125°C
ALTITUDE:		300,000 FEET
SHOCK:*	Z, Y, & V ENCLOSURES	200 g FOR 6 mS
	W, X & M ENCLOSURES	100 g FOR 6 mS
VIBRATION, SINUSOIDAL:*	Z, Y, & V ENCLOSURES	30 g 33-3000Hz
	W, X & M ENCLOSURES	20 g 33-3000Hz
VIBRATION, RANDOM: *	Z, Y, & V ENCLOSURES	0.4 g ² /Hz 50-2000Hz
	W, X & M ENCLOSURES	0.2 g ² /Hz 50-2000Hz
DIELECTRIC STRENGTH AT SEA LEVEL:	ALL CIRCUITS TO GROUND AND CIRCUIT TO CIRCUIT.	1250 V rms
	COIL TO GROUND	1000 V rms
DIELECTRIC STRENGTH AT 80,000 FEET:		350 V rms
INSULATION RESISTANCE:	INITIAL (500 VDC)	100 MΩ MINIMUM
	AFTER LIFE OR ENVIRONMENTAL TESTS	50 MΩ MINIMUM
OPERATE TIME AT NOMINAL VOLTAGE:	DC RELAYS	15 ms OR LESS
	AC RELAYS	20 ms OR LESS
RELEASE TIME AT NOMINAL VOLTAGE:	DC RELAYS	15 ms OR LESS
	AC RELAYS	50 ms OR LESS

* Max. contact opening under vibration or shock 10 microseconds



Tyco Electronics Mid-Range Military/Aerospace Relays

25 AMPERES, 3PDT

Below are shown the standard terminal types and the enclosures available. Specify the assembly as indicated under How To Order. Dimensions are shown in inches $\pm .010$ and (Millimeters $\pm .25$).

TERMINALS

CODE

"A"

Socket Pins - All DC Coils
PIN TERMINALS ARE GOLD PLATED

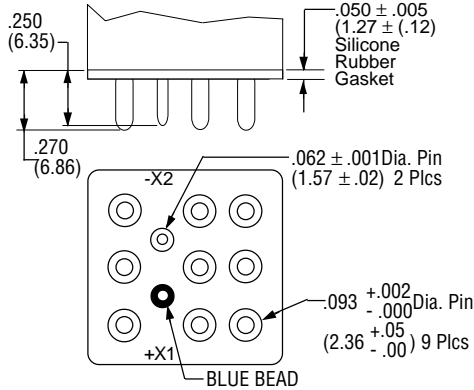

CODE

"B"

Solder Pin Terminals
PIN TERMINALS TIN/LEAD PLATED

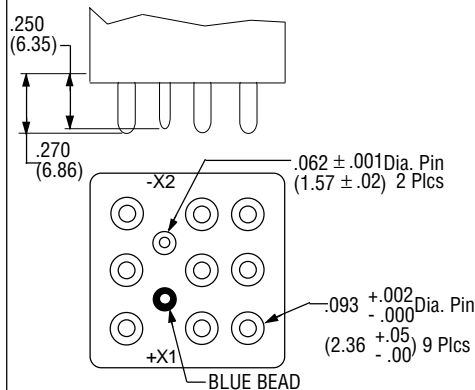

CODE

"C"

Solder Hook Terminals
HOOK TERMINALS TIN/LEAD PLATED

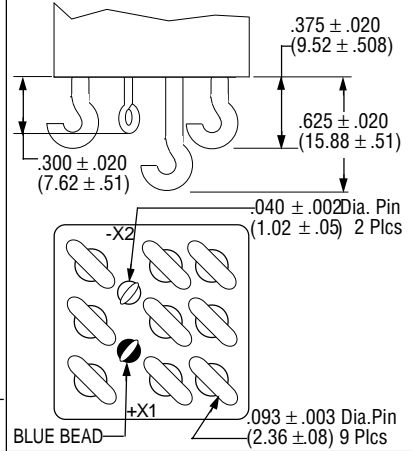

CODE

"V"

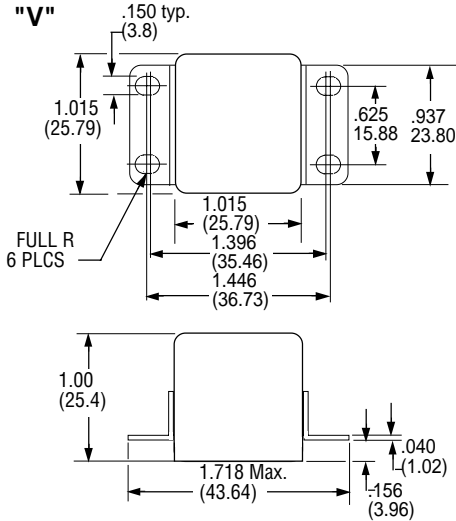

ENCLOSURES

All Enclosures have cupro-Nickel cans bright acid tin/lead plated after assembly to terminal headers.

Dimensions: Inches $\pm .010$ (mm $\pm .25$)

For socket pin terminals: specify "Y" enclosures with DC coils and "V" enclosures with AC coils.

CODE

"Z"

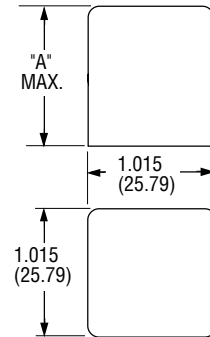

CODE

"Y"

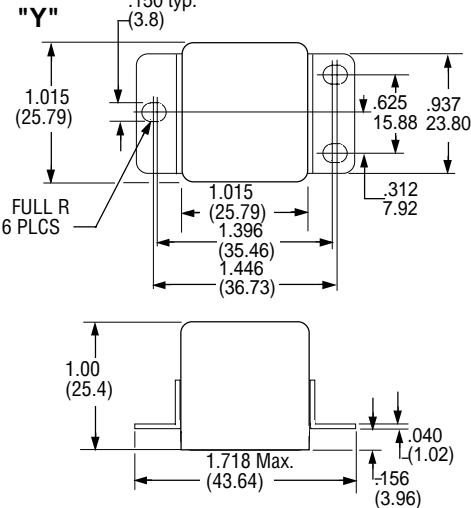

CODE

"X"

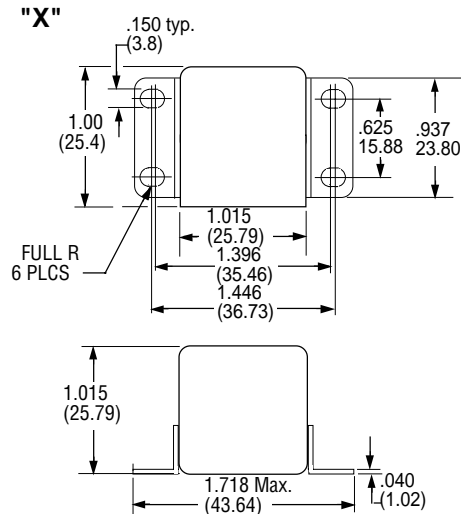

CODE

"W"

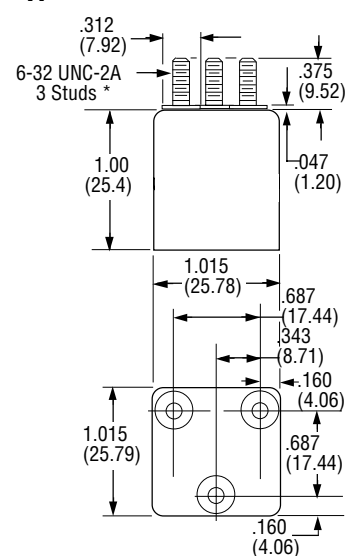

*Metric threads available, To specify use \square in place of \square



Tyco Electronics Mid-Range Military/Aerospace Relays

25 AMPERES, 3PDT

TERMINAL WIRING

DC COILS

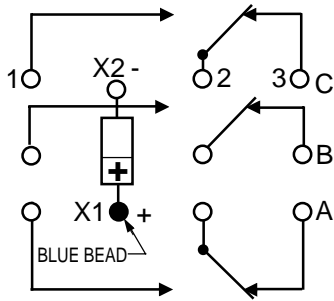

DC COILS WITH
TRANSIENT SUPPRESSION

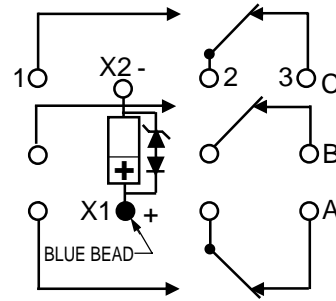

AC COILS

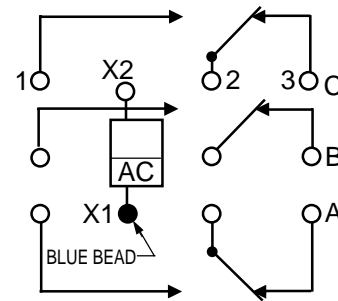

NOTE: Polarity must be observed with DC coil supply. Relay is polarized with a permanent magnet and will not operate or be damaged by reverse polarity.

Diodes used in transient suppression and in AC rectifier circuits have peak inverse voltage rating of 600 VDC minimum. Zener diodes have a minimum rating of 1 watt.

Terminal designations are for reference only and do not appear on the header.

TERMINAL LAYOUT

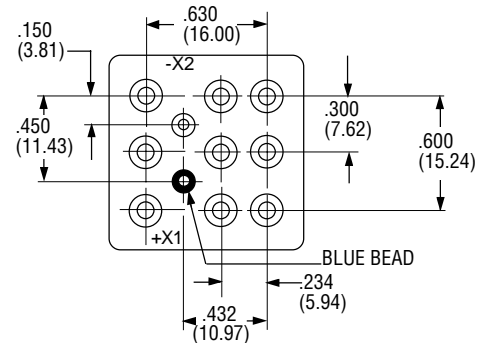

HOW TO ORDER

(EXAMPLE) _____ **FCA-325-A Y 4**

RELAY TYPE _____

TERMINALS (Socket Pins, DC Coil) _____

ENCLOSURE (With Flanges) _____

COIL (28 VDC With Transient Suppression). _____

NOTE: Only DC coil models are QPL Approved



Tyco Electronics Mid-Range Military/Aerospace Relays

25 AMPERES, 3PST-NO WITH 2 AMP SPDT AUXILIARY

- HERMETICALLY SEALED
- ALL WELDED CONSTRUCTION
- BALANCED FORCE
- PERMANENT MAGNET DRIVE
- CONTACTS: SILVER CADMIUM OXIDE WITH GOLD PLATING
- COILS FOR DC, 50 TO 400Hz AND 400Hz AC
- WEIGHT 2.89 OUNCES MAX. (82 GRAMS)

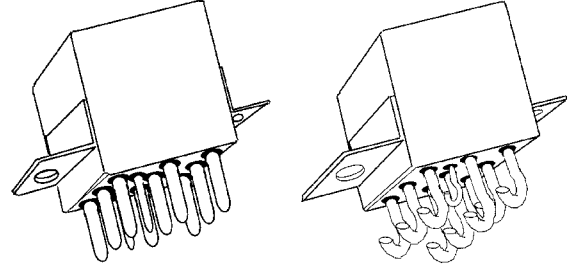

The Series FCAC-325 relay is a polarized single-side stable design, where the flux from a permanent magnet provides the armature holding force in the deactivated state, and its flux path is switched and combined with the coil flux in the operated state. This results in appreciably increased contact pressure in both states over that of a spring return nonpolar design. We also manufacture other versions of this relay:

- FCA-125:** 25 AMP SPDT RELAY
- FCA-325:** 25 AMP 3PDT RELAY

CONTACT RATING-AMPERES

Ratings Are Continuous Duty

TYPE OF LOAD	LIFE (MIN.) CYCLES X 10 ³	28 VDC		115VAC 400HZ		115/200VAC 400Hz-3Ø	115/200VAC 60Hz-3Ø *
		MAIN	AUX.	MAIN	AUX.		
Resistive	50	25	2	25	2	25	2.5
Inductive	10	12	1	-	-	-	2.5
Inductive	20	-	-	15	1	15	-
Motor	50	10	-	10	-	10	2.0
Lamp	50	5	.5	5	.5	5	1.0
* 60 Hz LOADS RATED FOR 10,000 OPERATIONS							

MAIN CONTACTS OVERLOAD CURRENT 50 AMPS DC, 80 AMPS 400HZ
 RUPTURE CURRENT 60 AMPS DC, 100 AMPS 400HZ
 CONTACT MAKE BOUNCE 1 MILLISECOND AT NOMINALVOLTAGE
 AUXILIARY CONTACT BOUNCE 4 MILLISECONDS MAX.
 MAX. CONTACT DROP AT 25 AMPS: INITIAL 0.150 VOLTS.
 END OF LIFE 0.175 VOLTS



Tyco Electronics Mid-Range Military/Aerospace Relays

25 AMPERES, 3PST-NO WITH 2 AMP SPDT AUXILIARY

COIL DATA

COIL CODE	NOMINAL VOLTAGES	FREQ. HZ	DC RES. AC AMPS (B)	OVER TEMPERATURE RANGE		
				PICKUP OR BELOW VOLTS	DROPOUT OR ABOVE VOLTS	MUST HOLD VOLTAGE (C)
1	6	DC	18 Ω	4.5	0.3	2.5
2	12	DC	70 Ω	9.0	0.75	4.5
3	28	DC	290 Ω	18.0	1.5	7.0
4 (A)	28	DC	290 Ω	18.0	1.5	7.0
5	48	DC	865 Ω	32.0	2.5	14.0
6	28	400HZ	225 mA	22.0	1.25	10.0
7	28	50/400Hz	120 mA	22.0	1.25	10.0
8	115	400 Hz	40 mA	90.0	5.0	40.0
9	115	50/400Hz	30 mA	95.0	5.0	40.0

- A. CODE 4 COILS HAVE BACK EMF SUPPRESSION TO 42 VOLTS MAX.
- B. DC COIL RESISTANCE ± 10% AT 25°C; AC COIL MAX. CURRENT AT NOMINAL VOLTAGE.
- C. RELAY WILL STAY IN PICKED-UP STATE DOWN TO MUST HOLD VOLTAGES SHOWN.
- D. MAX. OVERVOLTAGE: 6 & 12 VDC COILS 120% OF NOMINAL; ALL OTHERS 110% OF NOMINAL.
- E. COILS AVAILABLE FOR OTHER VOLTAGES AND FOR AC 50/60HZ.

GENERAL SPECIFICATIONS

TEMPERATURE RATING:		-70°C TO + 125°C
ALTITUDE:		300,000 FEET
SHOCK:*	Z, Y, & V ENCLOSURES	200 g FOR 6 mS
	W, X & M ENCLOSURES	100 g FOR 6 mS
VIBRATION, SINUSOIDAL:*	Z, Y, & V ENCLOSURES	30 g 33-3000Hz
	W, X & M ENCLOSURES	20 g 33-3000Hz
VIBRATION, RANDOM: *	Z, Y, & V ENCLOSURES	0.4 g ² /Hz 50-2000Hz
	W, X & M ENCLOSURES	0.2 g ² /Hz 50-2000Hz
DIELECTRIC STRENGTH AT SEA LEVEL:	ALL CIRCUITS TO GROUND AND CIRCUIT TO CIRCUIT.	1250 V rms
	COIL TO GROUND	1000 V rms
DIELECTRIC STRENGTH AT 80,000 FEET:		350 V rms
INSULATION RESISTANCE:	INITIAL (500 VDC)	100 MΩ MINIMUM
	AFTER LIFE OR ENVIRONMENTAL TESTS	50 MΩ MINIMUM
OPERATE TIME AT NOMINAL VOLTAGE:	DC RELAYS	15 ms OR LESS
	AC RELAYS	20 ms OR LESS
RELEASE TIME AT NOMINAL VOLTAGE:	DC RELAYS	15 ms OR LESS
	AC RELAYS	50 ms OR LESS

* Max. contact opening under vibration or shock 10 microseconds



Tyco Electronics Mid-Range Military/Aerospace Relays

25 AMPERES, 3PST-NO WITH 2 AMP SPDT AUXILIARY

Below are shown the standard terminal types and the enclosures available. Specify the assembly as indicated under How To Order. Dimensions are shown in inches $\pm .010$ and (Millimeters $\pm .25$) except as noted.

TERMINALS

CODE "A"

Socket Pin Terminals
Pin Terminals are Gold Plated

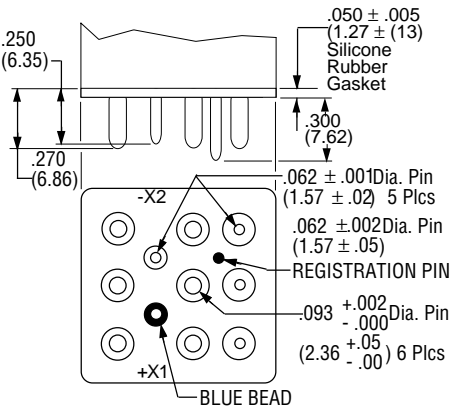

CODE "B"

Solder Pin Terminals
Pin Terminals are Tin/Lead Plated

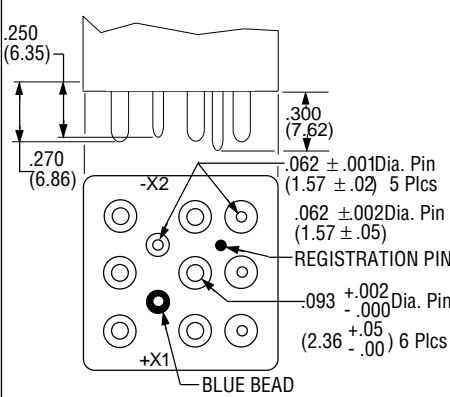

CODE "C"

Solder Hook Terminals
Hook Terminals are Tin/Lead Plated

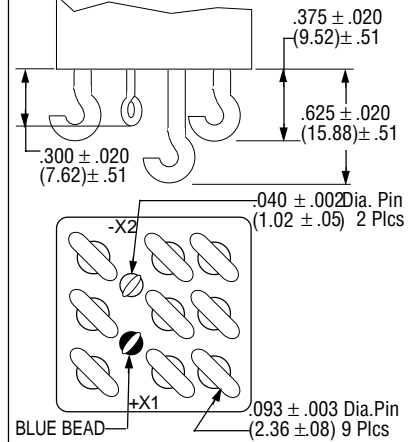

CODE "V"

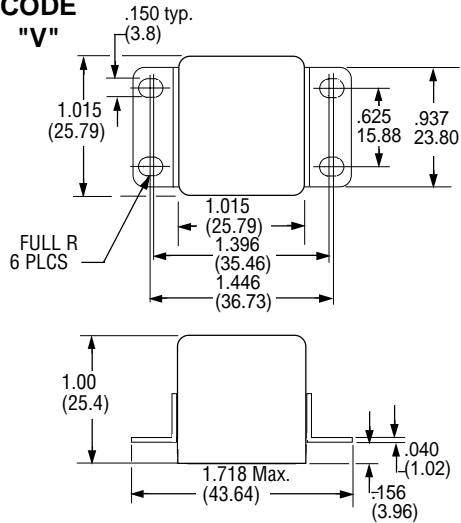

ENCLOSURES

All Enclosures have cupro-Nickel cans bright acid tin/lead plated after assembly to terminal headers.

Dimensions: Inches $\pm .010$ (mm $\pm .25$)

For socket pin terminals: specify "Y" enclosures with DC coils and "V" enclosures with AC coils.

CODE "Z"

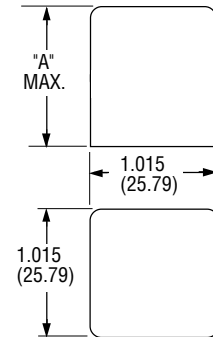

CODE "Y"

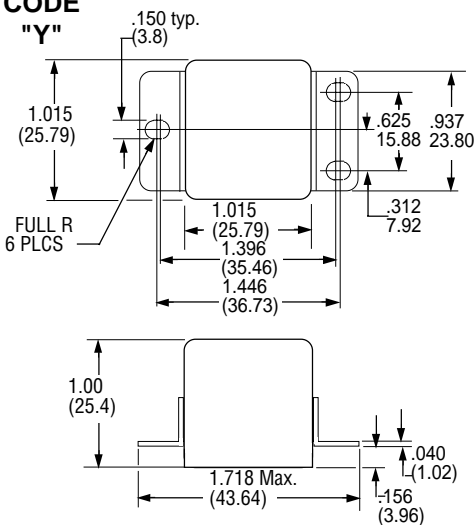

CODE "X"

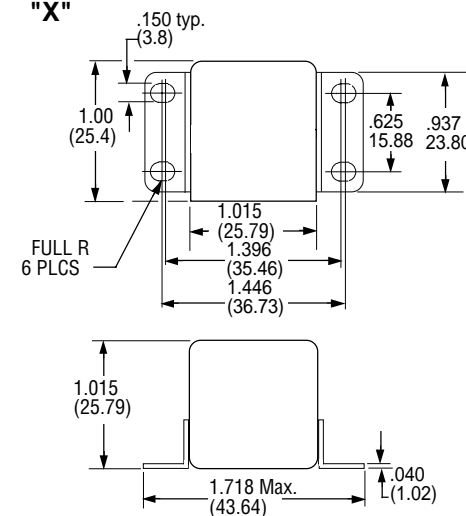

CODE "W"

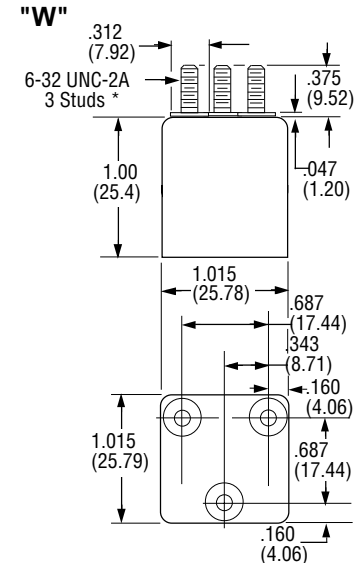

*Metric threads available, To specify use \square in place of \square



Tyco Electronics Mid-Range Military/Aerospace Relays

25 AMPERES, 3PST-NO WITH 2 AMP SPDT AUXILIARY

TERMINAL WIRING

DC COILS

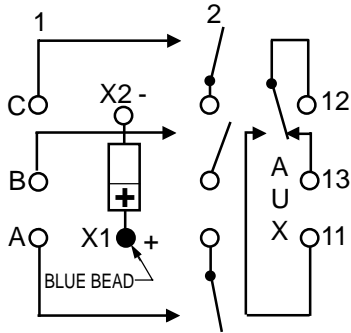

DC COILS WITH TRANSIENT SUPPRESSION

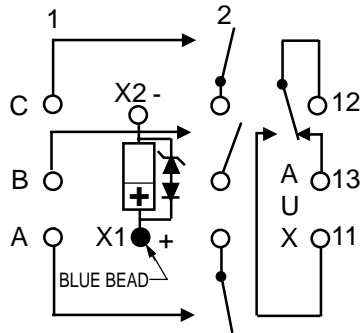

AC COILS

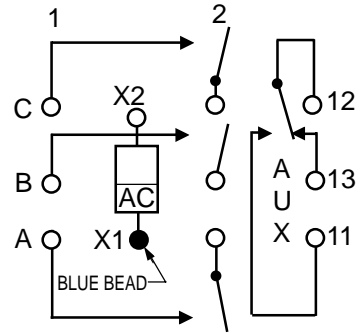

NOTE: Polarity must be observed with DC coil supply. Relay is polarized with a permanent magnet and will not operate or be damaged by reverse polarity.

Diodes used in transient suppression and in AC rectifier circuits have peak inverse voltage rating of 600 VDC minimum. Zener diodes have a minimum rating of 1 watt.

Terminal designations are for reference only and do not appear on the header.

TERMINAL LAYOUT

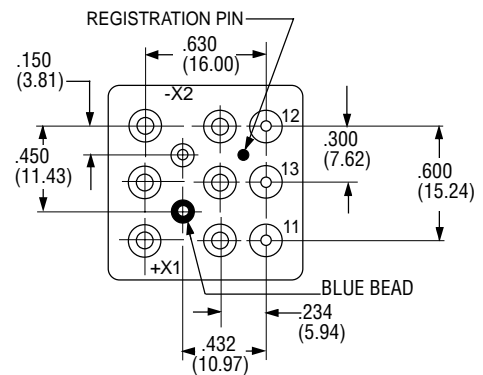

HOW TO ORDER

(EXAMPLE) _____ **FCAC-325-A Y 4**

RELAY TYPE _____

TERMINALS (Socket Pins, DC Coil) _____

ENCLOSURE (With Flanges and DC coil) _____

COIL (28 VDC With Transient Suppression). _____



SERIES
FCA-410

Tyco Electronics Mid-Range Military/Aerospace Relays

10 AMPERES, 4PDT



- HERMETICALLY SEALED
- ALL WELDED CONSTRUCTION
- BALANCED FORCE
- PERMANENT MAGNET DRIVE
- 4PDT SWITCHING IN ONE INCH CUBE
- CONTACTS: SILVER CADMIUM OXIDE WITH GOLD PLATING
- COILS FOR DC AND AC 50-400 Hz OR 400 Hz
- WEIGHT 2.72 OUNCES MAX. (77 GRAMS MAX.)

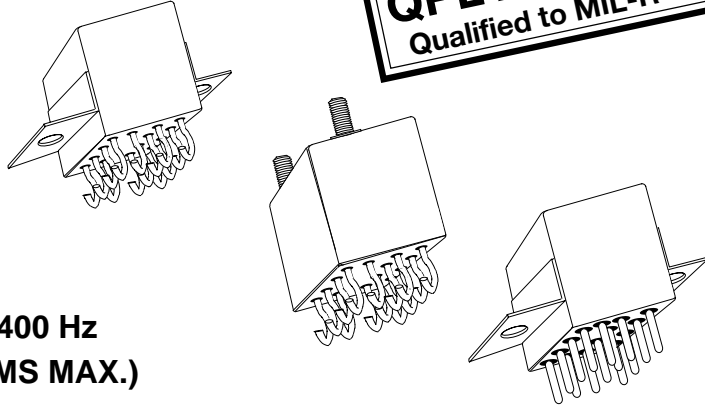

The Series FCA-410 relay is a polarized single-side stable design, where the flux from a permanent magnet provides the armature holding force in the deactivated state, and its flux path is switched and combined with the coil flux in the operated state. This results in appreciably increased contact pressure in both states over that of a spring return nonpolar design. We also manufacture 2-pole and 4-pole versions of this relay.

FCA-210: 10 AMP DPDT RELAY
FCA-610: 10 AMP 6PDT RELAY

AVAILABLE

FCA-415: 15 AMP 4PDT, HAS THE SAME SPECIFICATIONS AS THE FCA-410 EXCEPT IS RATED AT 15 AMPS.

CONTACT RATING-AMPERES

Ratings Are Continuous Duty

TYPE OF LOAD	LIFE (MIN.) CYCLES X 10 ³	28 VDC	120VAC 400HZ	120/200VAC 400Hz-3Ø	120/200VAC 60Hz-3Ø *
Resistive	100	10	10	10	2.5
Inductive	20	8	8	8	2.5
Motor	100	4	4	4	2.0
Lamp	100	2	2	2	1.0
* 60 Hz LOADS RATED FOR 10,000 OPERATIONS					

OVERLOAD CURRENT 40 AMPS DC, 60 AMPS 400HZ
RUPTURE CURRENT 50 AMPS DC, 80 AMPS 400HZ
CONTACT MAKE BOUNCE 1 MILLISECOND AT NOMINAL VOLTAGE
MAX. CONTACT DROP AT 10 AMPS: INITIAL 0.100 VOLTS.
END OF LIFE 0.125 VOLTS



Tyco Electronics Mid-Range Military/Aerospace Relays

10 AMPERES, 4PDT

COIL DATA

COIL CODE	NOMINAL VOLTAGES	FREQ. HZ	DC RES. AC AMPS (B)	OVER TEMPERATURE RANGE		
				PICKUP OR BELOW VOLTS	DROPOUT OR ABOVE VOLTS	MUST HOLD VOLTAGE (C)
1	6	DC	18 Ω	4.5	0.3	2.5
2	12	DC	70 Ω	9.0	0.75	4.5
3	28	DC	290 Ω	18.0	1.5	7.0
4 (A)	28	DC	290 Ω	18.0	1.5	7.0
5	48	DC	865 Ω	32.0	2.5	14.0
6	28	400HZ	225 mA	22.0	1.25	10.0
7	28	50/400Hz	120 mA	22.0	1.25	10.0
8	115	400 Hz	40 mA	90.0	5.0	40.0
9	115	50/400Hz	40 mA	95.0	5.0	40.0

- A. CODE 4 COILS HAVE BACK EMF SUPPRESSION TO 42 VOLTS MAX.
- B. DC COIL RESISTANCE ± 10% AT 25°C; AC COIL MAX. CURRENT AT NOMINAL VOLTAGE.
- C. RELAY WILL STAY IN PICKED-UP STATE DOWN TO COIL VOLTAGES SHOWN.
- D. MAX. OVERVOLTAGE: 6 & 12 VDC COILS 120% OF NOMINAL; ALL OTHERS 110% OF NOMINAL.
- E. COILS AVAILABLE FOR OTHER VOLTAGES AND FOR AC 50/60HZ.
- NOTE: Only DC Coil Models are QPL Approved.

GENERAL SPECIFICATIONS

TEMPERATURE RATING:		-70°C TO + 125°C
ALTITUDE:		300,000 FEET
SHOCK:	Z, & Y ENCLOSURES	200 G FOR 6 mS
	W, X & M ENCLOSURES	100G FOR 6 mS
VIBRATION, SINUSOIDAL:*	Z & Y ENCLOSURES	0.12 DA 10 TO 70Hz 30G 70 TO 3000 Hz
	W, X & M ENCLOSURES	0.12 DA 10 TO 57 Hz 20G 57 TO 3000 Hz
VIBRATION, RANDOM *	Z, & Y ENCLOSURES	0.4G ² /Hz 50-2000Hz
	W, X & M ENCLOSURES	0.2G ² /Hz 50-2000Hz
DIELECTRIC STRENGTH AT SEA LEVEL:	ALL CIRCUITS TO GROUND AND CIRCUIT TO CIRCUIT.	1250 V rms
	COIL TO GROUND	1000 V rms
DIELECTRIC STRENGTH AT 80,000 FEET:		350 V rms
INSULATION RESISTANCE:	INITIAL (500 VDC)	100 MΩ MINIMUM
	AFTER LIFE OR ENVIRONMENTAL TESTS	50 MΩ MINIMUM
OPERATE TIME AT NOMINAL VOLTAGE:	DC RELAYS	15 mS OR LESS
	AC RELAYS	20 mS OR LESS
RELEASE TIME AT NOMINAL VOLTAGE:	DC RELAYS	15 mS OR LESS
	AC RELAYS	50 mS OR LESS

* Max. contact opening under vibration or shock 10 microseconds



Tyco Electronics Mid-Range Military/Aerospace Relays

10 AMPERES, 4PDT

Below are shown the standard terminal types and the enclosures available. Note that the pin configuration for coil connections is determined by the coil supply voltage. Specify the assembly as indicated under How To Order. Dimensions are shown in inches $\pm .010$ and (Millimeters $\pm .25$) except as noted.

TERMINALS

Terminals on 0.200 centers.
Coil terminals: X1-X2; See Page 26.
Socket Pins are Gold Plated.
Circuit Board Pins are Tin/Lead Plated.

CODE "A"

Socket Pins-All DC Coils

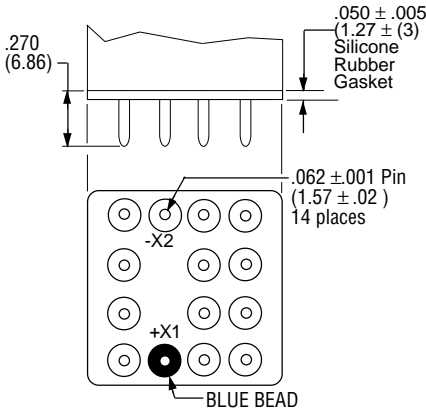

CODE "B"

Circuit Board Pins-All DC Coils

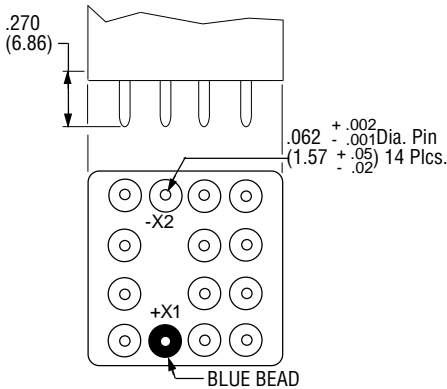

CODE "C"

Solder Hooks-AC or DC Coils

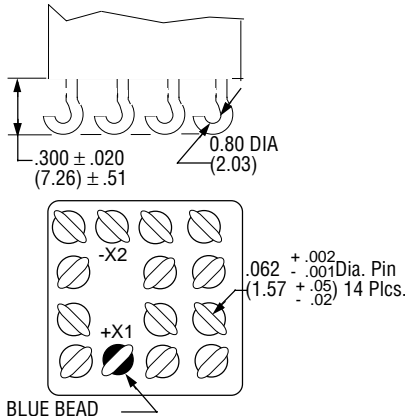

CODE "D"

Socket Pins-115 VAC Coils

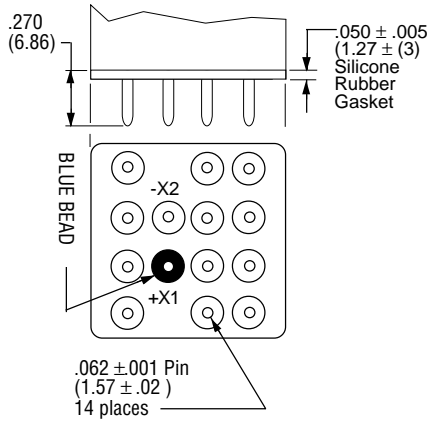

ENCLOSURES

All Enclosures have cupro-Nickel cans bright acid tin/lead plated after assembly to terminal headers.

CODE "Z"

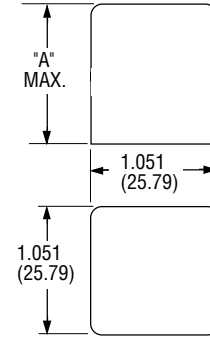

CODE "Y"

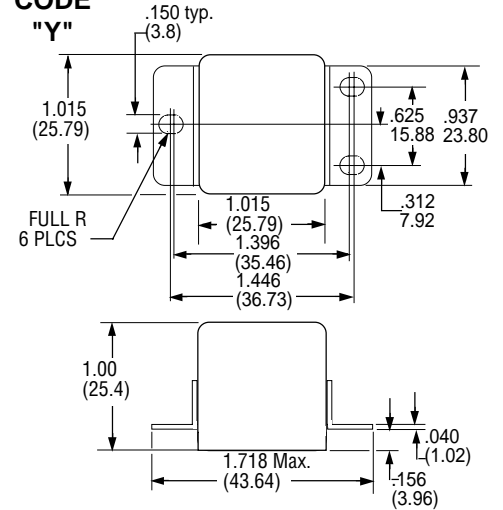

CODE "W"

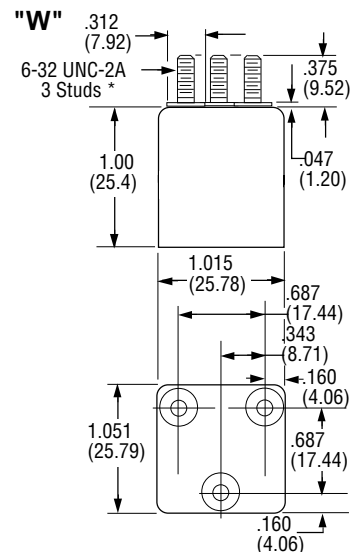

*Metric threads available, To specify use [M] in place of [W]

**SEE NEXT PAGE
FOR MORE COIL
TERMINAL OPTIONS**

CODE "X"

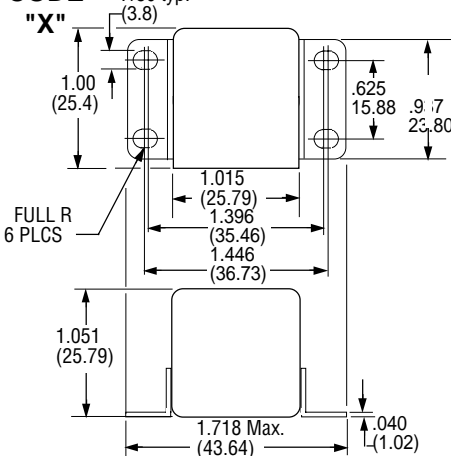



Tyco Electronics Mid-Range Military/Aerospace Relays

10 AMPERES, 4PDT

TERMINALS CONTINUED

CODE "E"
Socket Pins- 28 VAC Coils

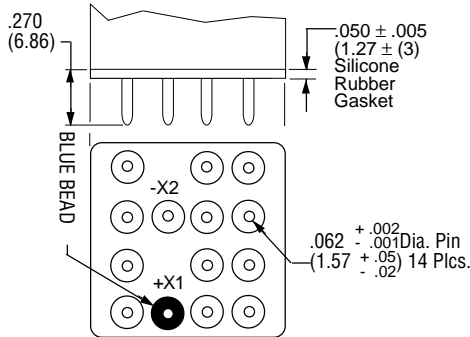

CODE "F"
Circuit Board Pins-115 VAC Coils

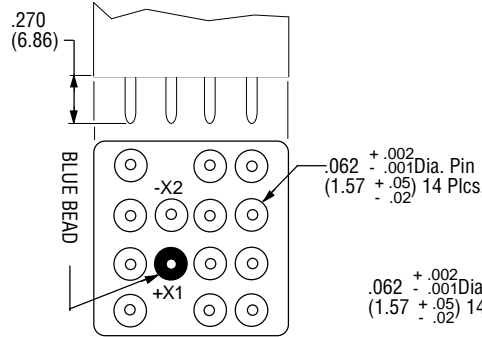

CODE "G"
Circuit Board Pins- 28 VAC Coils

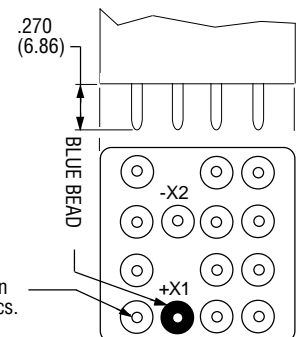

TERMINAL WIRING

A & B PIN TERMINAL
ALL DC COILS

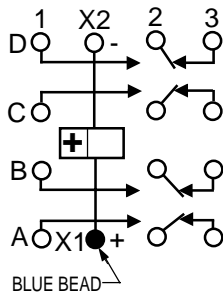

C HOOK TERMINAL
ALL AC & DC COILS

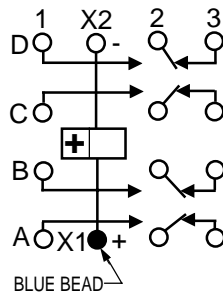

TRANSIENT SUPPRESSION CIR.

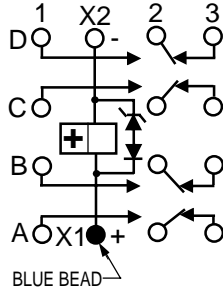

D & F PIN TERMINAL
115 VAC COILS

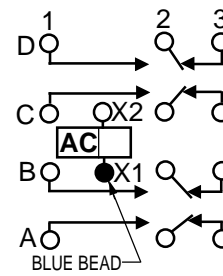

E & G PIN TERMINAL
28 VAC COILS

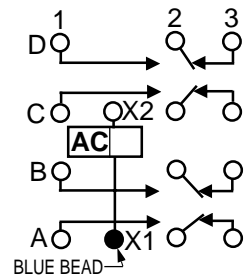

NOTE: Polarity must be observed with DC coil supply. Relay is polarized with a permanent magnet and will not operate or be damaged by reverse polarity.

Diodes used in transient suppression and in AC rectifier circuits have peak inverse voltage rating of 600 VDC minimum. Zener diodes have a minimum rating of 1 watt.

Terminal designations are for reference only and do not appear on the header.

TERMINAL LAYOUT

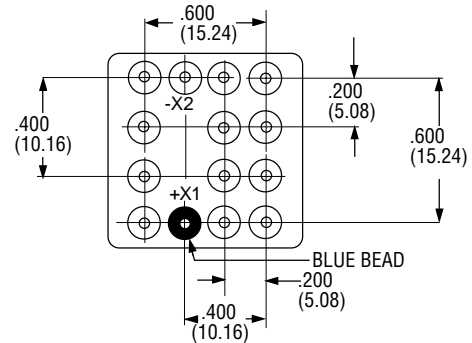

HOW TO ORDER

(EXAMPLE) _____ **FCA-415-**
FCA-410 **A Y 4**

RELAY TYPE _____

TERMINALS (Socket Pins) _____

ENCLOSURE (With Flanges) _____

COIL (28 VDC With Transient Suppression) _____

NOTE: Only DC coil models are QPL Approved



Tyco Electronics Mid-Range Military/Aerospace Relays

10 AMPERES, 6PDT



- HERMETICALLY SEALED
- ALL WELDED CONSTRUCTION
- BALANCED FORCE
- PERMANENT MAGNET DRIVE
- 6PDT SWITCHING IN 1.4 CU INCH
- CONTACTS: SILVER CADMIUM OXIDE WITH GOLD PLATING
- COILS FOR DC AND 400 Hz
- WEIGHT 4.16 OUNCES MAX. (117.94 GRAMS MAX.)

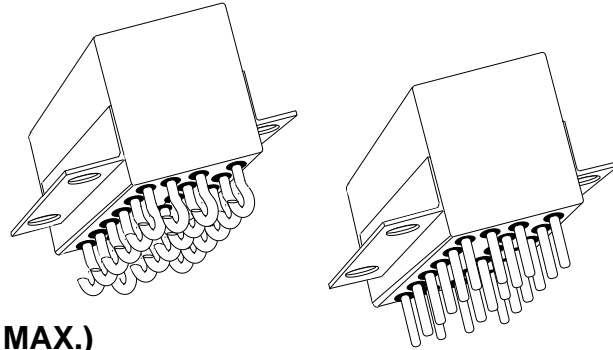

The Series FCA-610 relay is a polarized single-side stable design, where the flux from a permanent magnet provides the armature holding force in the deactivated state, and its flux path is switched and combined with the coil flux in the operated state. This results in appreciably increased contact pressure in both states over that of a spring return nonpolar design. We also manufacture 2-pole and 4-pole versions of this relay.

FCA-210: 10 AMP DPDT RELAY
FCA-410: 10 AMP 4PDT RELAY

CONTACT RATING-AMPERES

Ratings Are Continuous Duty

TYPE OF LOAD	LIFE (MIN.) CYCLES X 10 ³	28 VDC	115VAC 400HZ	115/200VAC 400Hz-3Ø
Resistive	100	10	10	10
Inductive	20	8	8	8
Motor	100	4	4	4
Lamp	100	2	2	2
* 60 Hz LOADS RATED FOR 10,000 OPERATIONS				

OVERLOAD CURRENT 40 AMPS DC, 60 AMPS 400HZ
RUPTURE CURRENT 50 AMPS DC, 80 AMPS 400HZ
CONTACT MAKE BOUNCE 1 MILLISECOND AT NOMINAL VOLTAGE
MAX. CONTACT DROP AT 10 AMPS: INITIAL 0.100 VOLTS.
END OF LIFE 0.125 VOLTS



Tyco Electronics Mid-Range Military/Aerospace Relays

10 AMPERES, 6PDT

COIL DATA

COIL CODE	NOMINAL VOLTAGES	FREQ. Hz	DC RES. AC AMPS (B)	OVER TEMPERATURE RANGE		
				PICKUP OR BELOW VOLTS	DROPOUT OR ABOVE VOLTS	MUST HOLD VOLTAGE (C)
1	6	DC	8.5 Ω	4.5	0.3	2.5
2	12	DC	33 Ω	9.0	0.75	4.5
3	28	DC	180 Ω	18.0	1.5	7.0
4 (A)	28	DC	180 Ω	18.0	1.5	7.0
5	48	DC	530 Ω	32.0	2.5	14.0
8	115	400H z	60 mA	90.0	5.0	40.0

- A. CODE 4 COILS HAVE BACK EMF SUPPRESSION TO 42 VOLTS MAX.
- B. DC COIL RESISTANCE $\pm 10\%$ AT 25°C; AC COIL MAX. CURRENT AT NOMINAL VOLTAGE.
- C. RELAY WILL STAY IN PICKED-UP STATE DOWN TO MUST HOLD VOLTAGES SHOWN.
- D. MAX. OVERVOLTAGE: 6 & 12 VDC COILS 120% OF NOMINAL; ALL OTHERS 110% OF NOMINAL.
- E. COILS AVAILABLE FOR OTHER VOLTAGES AND FOR AC 50/60HZ.
- NOTE: Only DC Coil Models are QPL Approved.

GENERAL SPECIFICATIONS

TEMPERATURE RATING:		-70°C TO + 125°C
ALTITUDE:		300,000 FEET
SHOCK:*	Z, Y & X ENCLOSURES	50 g FOR 6 TO 9 mS
VIBRATION, SINUSOIDAL:*	Z, Y & X ENCLOSURES	20 g TO 2000Hz
VIBRATION, RANDOM: *	Z, Y & X ENCLOSURES	0.3 g ² /Hz 50-2000Hz
DIELECTRIC STRENGTH AT SEA LEVEL:	ALL CIRCUITS TO GROUND AND CIRCUIT TO CIRCUIT.	1250 V rms
	COIL TO GROUND	1000 V rms
DIELECTRIC STRENGTH AT 80,000 FEET:		350 V rms
INSULATION RESISTANCE:	INITIAL (500 VDC)	100 MΩ MINIMUM
	AFTER LIFE OR ENVIRONMENTAL TESTS	50 MΩ MINIMUM
OPERATE TIME AT NOMINAL VOLTAGE:	DC RELAYS	15 ms OR LESS
	AC RELAYS	20 ms OR LESS
RELEASE TIME AT NOMINAL VOLTAGE:	DC RELAYS	15 ms OR LESS
	AC RELAYS	50 ms OR LESS

* Max. contact opening under vibration or shock 10 microseconds



Tyco Electronics Mid-Range Military/Aerospace Relays

10 AMPERES, 6PDT

Below are shown the standard terminal types and the enclosures available. Note that the pin configuration for coil connections is determined by the coil supply voltage. Specify the assembly as indicated under How To Order. Dimensions are shown in inches $\pm .010$ and (Millimeters $\pm .25$) except as noted.

TERMINALS

Terminals on 0.200 centers.
Coil terminals: X1-X2; See Page 30.
Socket Pins are Gold Plated.
Circuit Board Pins are Tin/Lead Plated.

CODE "A"

Socket Pins-All DC Coils

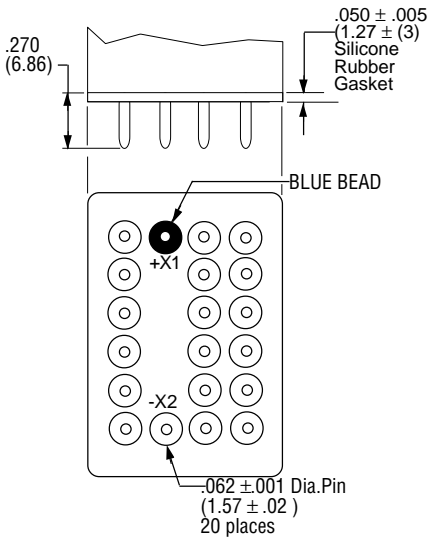

CODE "C"

Solder Hooks-AC or DC Coils

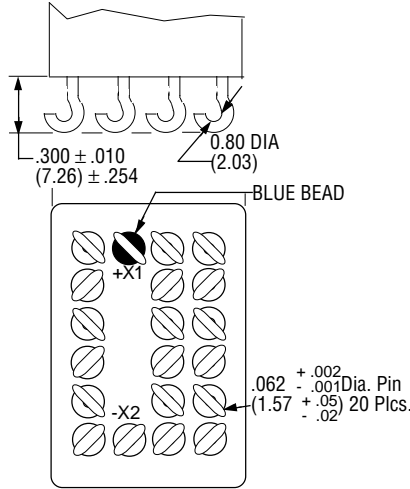

CODE "D"

Socket Pins-All AC Coils

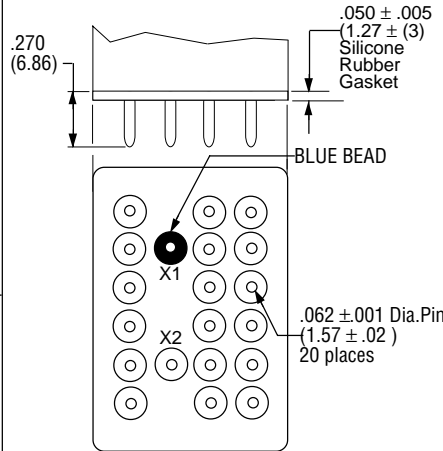

CODE "B"

Circuit Board Pins-All DC Coils

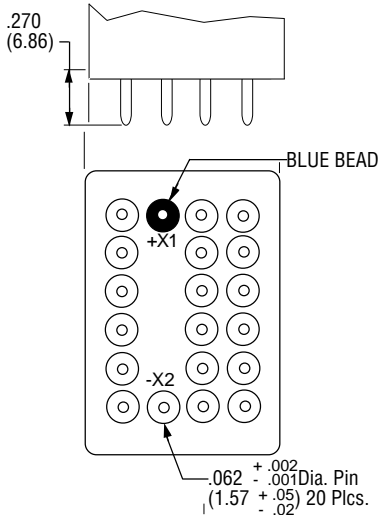

CODE "F"

Circuit Board Pins-All AC Coils

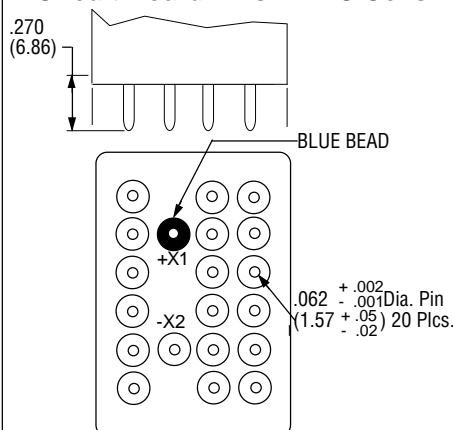

ENCLOSURES

All Enclosures have cupro-Nickel cans bright acid tin/lead plated after assembly to terminal headers.

CODE

"Z"

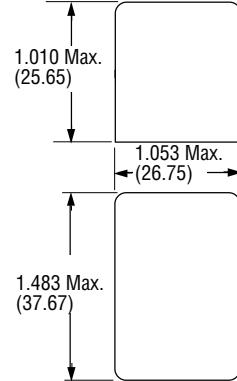

CODE

"Y"

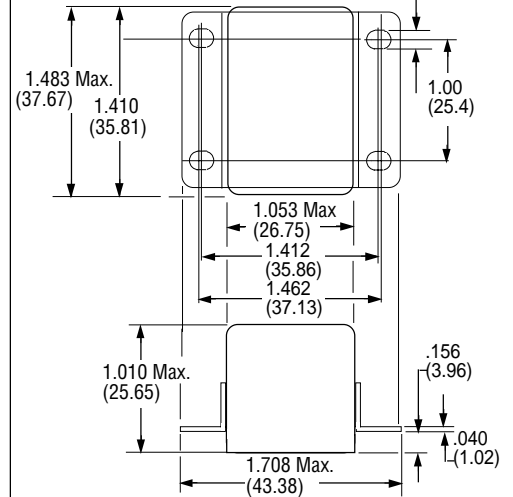

CODE

"X"

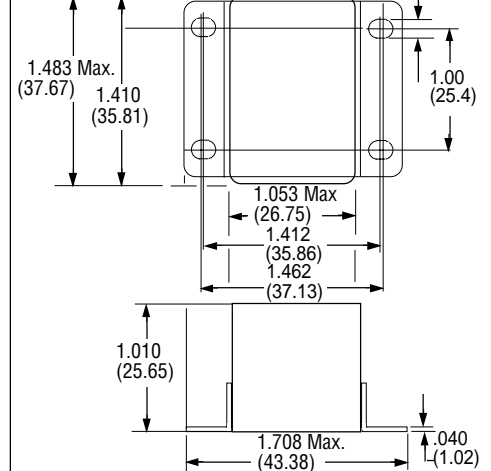



Tyco Electronics Mid-Range Military/Aerospace Relays

10 AMPERES, 6PDT

TERMINAL WIRING

ALL DC COILS & AC
SOLDER HOOKS

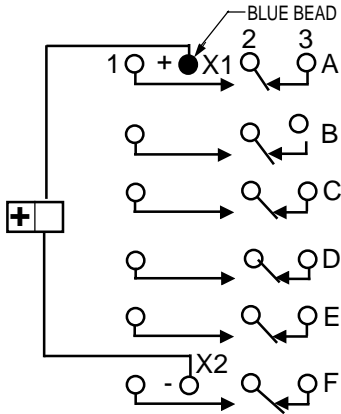

DC COILS WITH
TRANSIENT SUPPRESSION

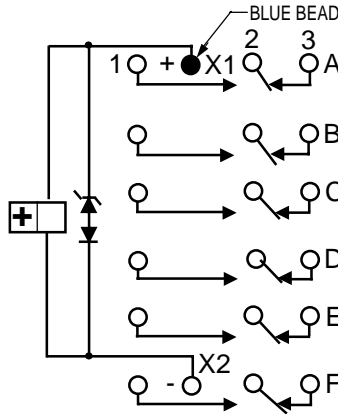

AC COILS (SOCKET PINS)

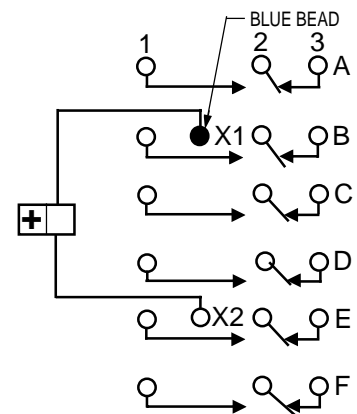

NOTE: Polarity must be observed with DC coil supply. Relay is polarized with a permanent magnet and will not operate or be damaged by reverse polarity.

Diodes used in transient suppression and in AC rectifier circuits have peak inverse voltage rating of 600 VDC minimum. Zener diodes have a minimum rating of 1 watt.

Terminal designations are for reference only and do not appear on the header.

TERMINAL LAYOUT

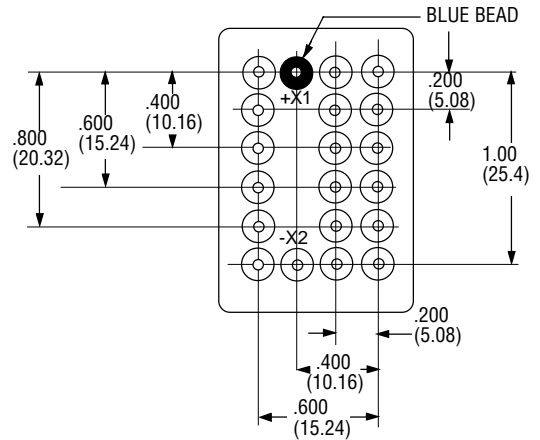

HOW TO ORDER

(EXAMPLE) _____ **FCA-610- A Y 4**

RELAY TYPE _____

TERMINALS (Socket Pins DC Coils) _____

ENCLOSURE (With Flanges) _____

COIL (28 VDC With Transient Suppression). _____

NOTE: Only DC coil models are QPL Approved



Mid-Range Military/Aerospace Relays

Section 2

FCB Relay Family



Tyco Electronics Mid-Range Military/Aerospace Relays

5 AMPERES, DPDT

- HERMETICALLY SEALED
- ALL WELDED CONSTRUCTION
- BALANCED FORCE
- PERMANENT MAGNET DRIVE
- CONTACTS RATED LOW LEVEL
- TO 5 AMPS 28 VDC AND 115/200 VAC
400 Hz , 3 PHASE.
- WEIGHT .54 OUNCES MAX. (15.4 GRAMS)

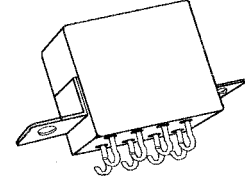
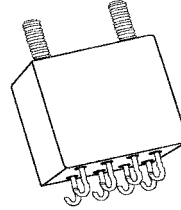
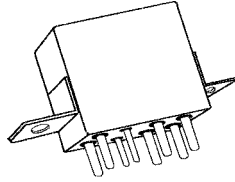

The Series FCB-205 relay is a polarized single-side stable design, where the flux from a permanent magnet provides the armature holding force in the deactivated state, and its flux path is switched and combined with the coil flux in the operated state. This results in appreciably increased contact pressure in both states over that of a spring return nonpolar design. We also manufacture other forms of the FCB relay:

- FCB-405:** 5 AMP 4PDT RELAY
- FCB-310:** 10 AMP 3PDT RELAY

CONTACT RATING-AMPERES

Ratings Are Continuous Duty

TYPE OF LOAD	LIFE (MIN.) CYCLES X 10 ³	28 VDC	115VAC 400Hz	115/200VAC 400 Hz, 3 ϕ
Resistive	100	5	5	5
Inductive	20	3	5	5
Motor	100	2	3	3
Lamp	100	1	1	1
* 60 Hz LOADS RATED FOR 10,000 OPERATIONS				

Low Level Switching Capability: With contacts operating a load of 10 to 50 microamperes at 10 to 50 millivolts, the contact resistance miss detection level shall be 100 ohms max. Cycling rate is 1 to 12 per second, for 100,000 operations.

OVERLOAD CURRENT 20 AMPS DC, 30AMPS 400Hz
RUPTURE CURRENT 25 AMPS DC, 40 AMPS 400Hz
CONTACT MAKE BOUNCE 1.0 MILLISECOND MAX. AT NOMINAL VOLTAGE
MAX. CONTACT DROP AT 5 AMPS: INITIAL 0.100 VOLTS.
END OF LIFE 0.125 VOLTS



Tyco Electronics Mid-Range Military/Aerospace Relays

5 AMPERES, DPDT

COIL DATA

COIL CODE	NOMINAL VOLTAGES	FREQ. Hz	DC RES. (B)	OVER TEMPERATURE RANGE		
				PICKUP OR BELOW VOLTS	DROPOUT OR ABOVE VOLTS	MUST HOLD VOLTAGE (C)
1	6	DC	31 Ω	4.5	0.3	2.5
2	12	DC	125 Ω	9.0	0.75	4.5
3	28	DC	500 Ω	18.0	1.5	7.0
4 (A)	28	DC	500 Ω	18.0	1.5	7.0
5	48	DC	1600 Ω	36.0	2.5	14.0

- A. CODE 4 COILS HAVE BACK EMF SUPPRESSION TO 42 VOLTS MAX.
 B. DC COIL RESISTANCE ± 10% AT 25°C;
 C. RELAY WILL STAY IN PICKUP STATE DOWN TO MUST HOLD VOLTAGES SHOWN.
 D. MAX. OVERVOLTAGE: 6 & 12 VDC COILS 120% OF NOMINAL; ALL OTHERS 110% OF NOMINAL.
- NOTE: Only DC Coil Models are QPL Approved.

GENERAL SPECIFICATIONS

TEMPERATURE RATING:		-70°C TO + 125°C
ALTITUDE:		300,000 FEET
SHOCK:*	Z, Y, & X ENCLOSURES	200 g FOR 6 mS
	W & M ENCLOSURES (STUD MTG.)	100 g FOR 6 mS
	T ENCLOSURE (SOCKET MOUNTED IN TRACK)	50 g FOR 11 mS
VIBRATION, SINUSOIDAL:*	Z, Y, & X ENCLOSURES	0.12 DA 10 TO 70 Hz 30 g 70-3000Hz
	W & M ENCLOSURES	0.12 DA 10 TO 57 Hz 20 g 57-3000Hz
	T ENCLOSURE IN TRACK	0.06DA 10 TO 57 Hz 10 g 57 TO 500 Hz 20 g 500 TO 3000 Hz
VIBRATION, RANDOM: *	Z, Y & X ENCLOSURES	0.4 g ² /Hz 50-2000Hz
	T, W & M ENCLOSURES	0.2 g ² /Hz 50-2000Hz
DIELECTRIC STRENGTH AT SEA LEVEL:	ALL CIRCUITS TO GROUND AND CIRCUIT TO CIRCUIT.	1000 V rms
	COIL TO GROUND	1000 V rms
DIELECTRIC STRENGTH AT 80,000 FEET:		250 V rms
INSULATION RESISTANCE:	INITIAL (500 VDC)	100 MΩ MINIMUM
	AFTER LIFE OR ENVIRONMENTAL TESTS	50 MΩ MINIMUM
OPERATE TIME AT NOMINAL VOLTAGE:		4 ms OR LESS
RELEASE TIME AT NOMINAL VOLTAGE:		4 ms OR LESS

* Max. contact opening under vibration or shock 10 microseconds



Tyco Electronics Mid-Range Military/Aerospace Relays

5 AMPERES, DPDT

Below are shown the standard terminal types and the enclosures available. Specify the assembly as indicated under How To Order. Dimensions are shown in inches ± .010 and (Millimeters ± .25).

TERMINALS

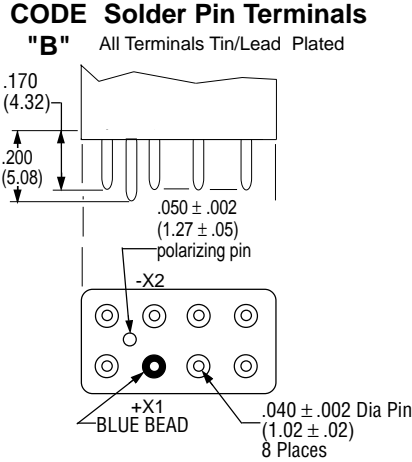
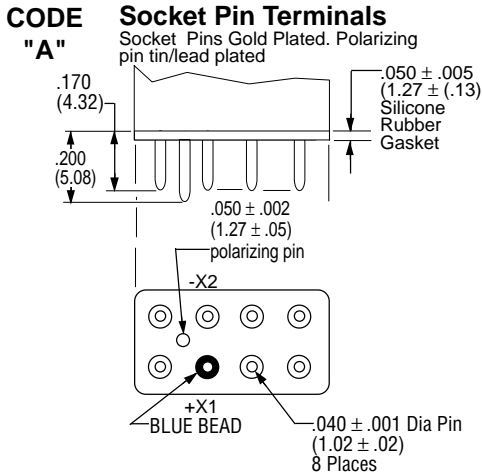

CODE "C" Solder Hook Terminals
Hook Terminals Tin/Lead Plated

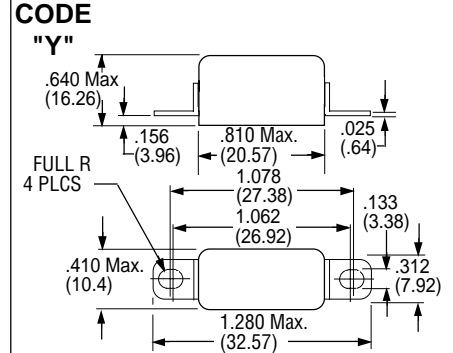
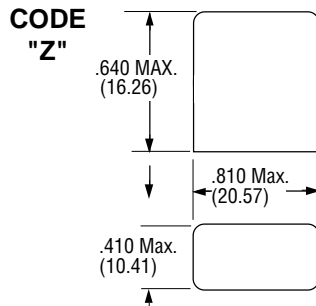
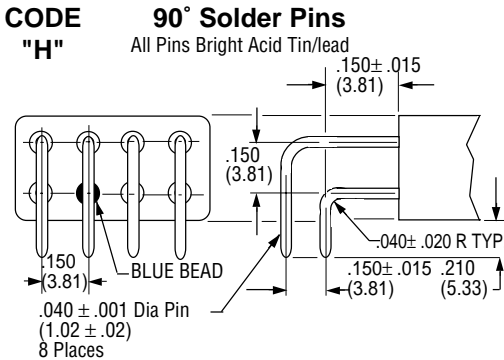
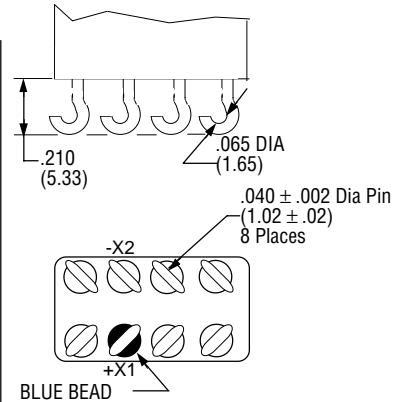

ENCLOSURES

All Enclosures have Cupro-Nickel Cans bright acid tin/lead plated after assembly to terminal headers.

Dimensions: Inches ± .010 (mm ± .25)

Enclosure "T" is for use with track mounted sockets and requires socket pin terminals, but no gasket. The gasket is included in the socket assembly.

CODE "X"

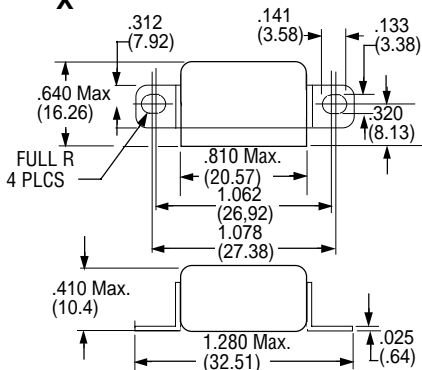

CODE "W"

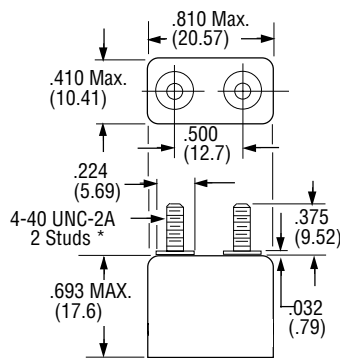

*Metric threads available, To specify use **M** in place of **W**

CODE "T"

M83536/2-028
(REFERENCE ONLY)

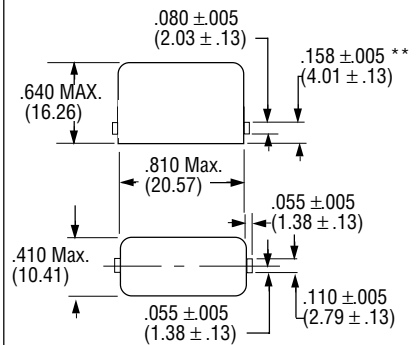

NOTE: FOR USE WITH TRACK MOUNT PER MIL-R-6106/23
** MEASURED FROM SURFACE OF HEADER



Tyco Electronics Mid-Range Military/Aerospace Relays

5 AMPERES, DPDT

TERMINAL WIRING

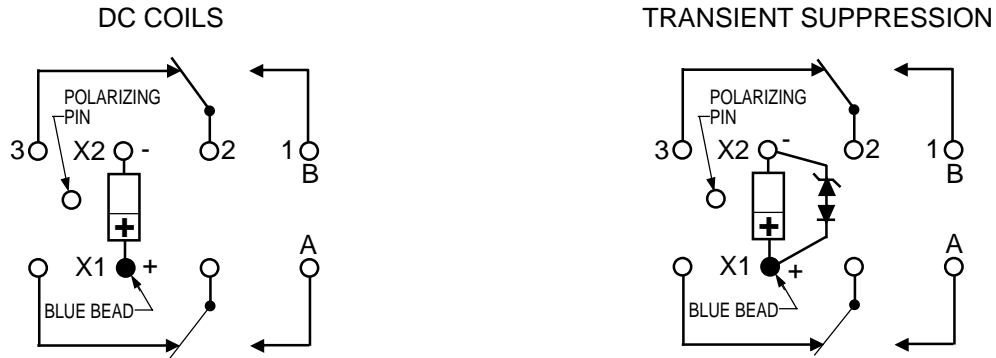

NOTE: Polarity must be observed with DC coil supply. Relay is polarized with a permanent magnet and will not operate or be damaged by reverse polarity.

Diodes used in transient suppression and in AC rectifier circuits have peak inverse voltage rating of 600 VDC minimum. Zener diodes have a minimum rating of 1 watt.

Terminal designations are for reference only and do not appear on the header.

TERMINAL LAYOUT

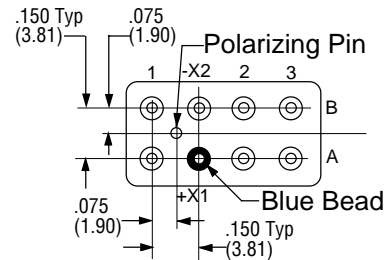

HOW TO ORDER

(EXAMPLE) _____ **FCB-205- A Y 4**

RELAY TYPE _____

TERMINALS (Socket Pins) _____

ENCLOSURE (With Flanges) _____

COIL (28 VDC With Transient Suppression). _____

NOTE: Only DC coil models are QPL Approved



Tyco Electronics Mid-Range Military/Aerospace Relays

10 AMPERES, 3PDT

**DESIGNED TO MEET
M83536/21 & 22**

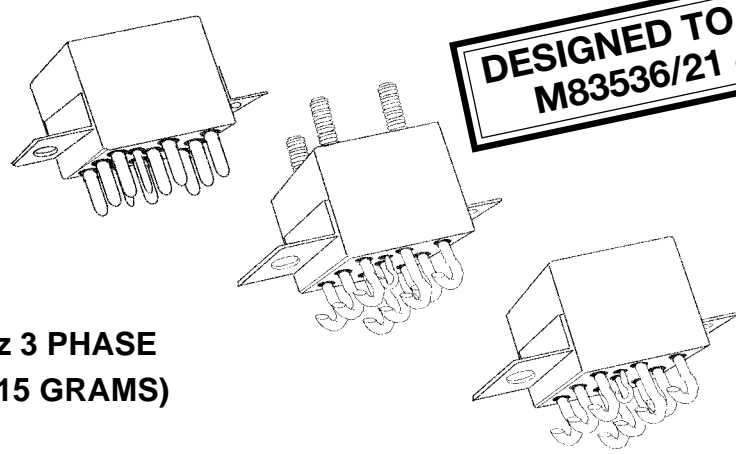

- HERMETICALLY SEALED
- ALL WELDED CONSTRUCTION
- BALANCED FORCE
- PERMANENT MAGNET DRIVE
- CONTACTS RATED LOW LEVEL TO 10 AMPS
- 28 VDC AND 115/200 VAC 400 Hz 3 PHASE
- WEIGHT .99 OUNCES MAX. (28.15 GRAMS)

The Series FCB-310 relay is a polarized single-side stable design, where the flux from a permanent magnet provides the armature holding force in the deactivated state, and its flux path is switched and combined with the coil flux in the operated state. This results in appreciably increased contact pressure in both states over that of a spring return nonpolar design. We also manufacture other versions of this relay:

- FCB-205: 5 AMP DPDT RELAY**
- FCB-405: 5 AMP 4PDT RELAY**

CONTACT RATING-AMPERES

Ratings Are Continuous Duty

TYPE OF LOAD	LIFE (MIN.) CYCLES X 10 ³	28 VDC	115VAC 400HZ	115AC 400Hz-	115/200VAC 400Hz-3Ø
Resistive	50	10	10	10	10
Inductive	10	6	-	-	-
Inductive	20	-	8	8	8
Motor	50	4	4	4	4
Lamp	50	2	2	2	2

Low Level Switching Capability: With contacts operating a load of 10 to 50 microamperes at 10 to 50 millivolts, the contact resistance miss detection level shall be 100 ohms max. Cycling rate is 1 to 12 per second, for 100,000 operations.

OVERLOAD CURRENT 30 AMPS DC, 60 AMPS 400HZ
RUPTURE CURRENT 40AMPS DC, 80 AMPS 400HZ
CONTACT MAKE BOUNCE 1 MILLISECOND AT NOMINAL VOLTAGE
MAX. CONTACT DROP AT 10 AMPS: INITIAL 0.100 VOLTS.
END OF LIFE 0.125 VOLTS



Tyco Electronics Mid-Range Military/Aerospace Relays

10 AMPERES, 3PDT

COIL DATA

COIL CODE	NOMINAL VOLTAGES	FREQ. HZ	DC RES (B).	OVER TEMPERATURE RANGE		
				PICKUP OR BELOW VOLTS	DROPOUT OR ABOVE VOLTS	MUST HOLD VOLTAGE (C)
1	6	DC	25 Ω	4.5	0.3	2.5
2	12	DC	100 Ω	9.0	0.75	4.5
3	28	DC	400 Ω	18.0	1.5	7.0
4 (A)	28	DC	400 Ω	18.0	1.5	7.0
5	48	DC	1275 Ω	36.0	2.5	14.0

- A. CODE 4 COILS HAVE BACK EMF SUPPRESSION TO 42 VOLTS MAX. D. MAX. OVER-VOLTAGE: 6 & 12 VDC COILS 120% OF NOMINAL; ALL OTHERS 110% OF NOMINAL.
- B. DC COIL RESISTANCE ± 10% AT 25°C;
- C. RELAY WILL STAY IN PICKED-UP STATE DOWN TO MUST HOLD VOLTAGES SHOWN.

GENERAL SPECIFICATIONS

TEMPERATURE RATING:		-70°C TO + 125°C
ALTITUDE:		300,000 FEET
SHOCK:*	Z, & Y ENCLOSURES	200 g FOR 6 mS
	W, X & M ENCLOSURES	100 g FOR 6 mS
	T ENCLOSURE (IN TRACK)	50 g FOR 11 mS
VIBRATION, SINUSOIDAL:*	Z, & Y ENCLOSURES	30 g 70-3000Hz
	W, X & M ENCLOSURES	20 g 70-3000Hz
	T ENCLOSURE (IN TRACK)	10 g 57-500 Hz 20 g 500-3000 Hz
VIBRATION, RANDOM: *	Z, & Y ENCLOSURES	0.4 g ² /Hz 50-2000Hz
	T, W & M ENCLOSURES	0.2 g ² /Hz 50-2000Hz
DIELECTRIC STRENGTH AT SEA LEVEL:	ALL CIRCUITS TO GROUND AND CIRCUIT TO CIRCUIT.	1000 V rms
	COIL TO GROUND	1000 V rms
DIELECTRIC STRENGTH AT 80,000 FEET:		250 V rms
INSULATION RESISTANCE:	INITIAL (500 VDC)	100 MΩ MINIMUM
	AFTER LIFE OR ENVIRONMENTAL TESTS	50 MΩ MINIMUM
OPERATE TIME AT NOMINAL VOLTAGE:		6 ms OR LESS
RELEASE TIME AT NOMINAL VOLTAGE:		6 ms OR LESS

* Max. contact opening under vibration or shock 10 microseconds



Tyco Electronics Mid-Range Military/Aerospace Relays

10 AMPERES, 3PDT

Below are shown the standard terminal types and the enclosures available. Specify the assembly as indicated under How To Order. Dimensions are shown in inches $\pm .010$ and (Millimeters $\pm .25$).

TERMINALS

CODE
"A"

Socket Pins - All DC Coils
PIN TERMINALS ARE GOLD PLATED

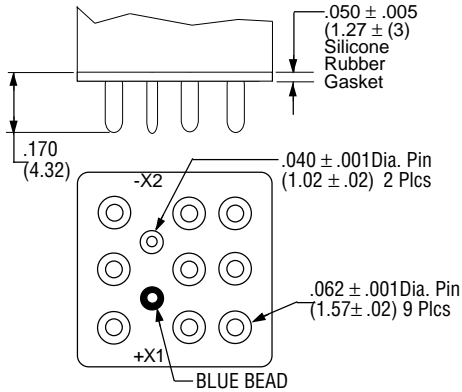

CODE
"B"

Solder Pin Terminals
PIN TERMINALS TIN/LEAD PLATED

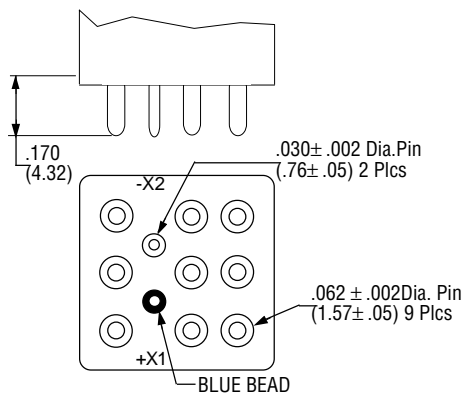

CODE
"C"

Solder Hook Terminals
HOOK TERMINALS TIN/LEAD PLATED

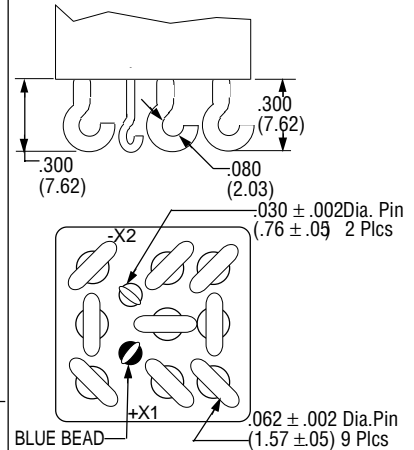

CODE
"T"

M83536/22-025
(REFERENCE ONLY)

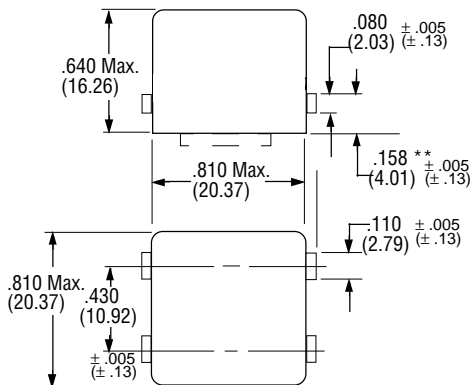

ENCLOSURES

All Enclosures have cupro-Nickel cans bright acid tin/lead plated after assembly to terminal headers.

Dimensions: Inches $\pm .010$ (mm $\pm .25$)

Enclosure "T" is for use with track mounted sockets and requires socket pin terminals, but no gasket. The gasket is included in the socket assembly.

CODE
"Z"

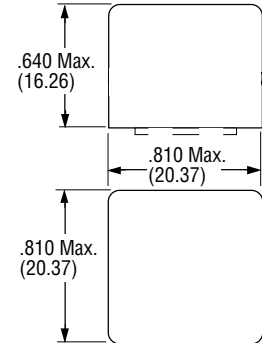

CODE
"Y"

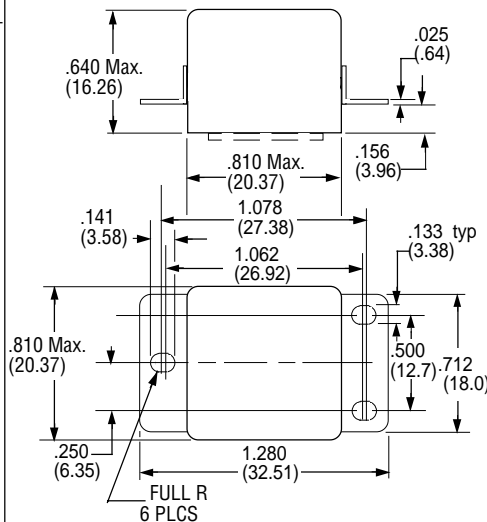

CODE
"X"

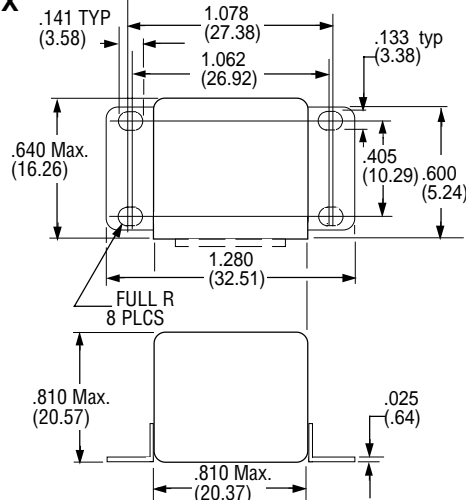

CODE
"W"

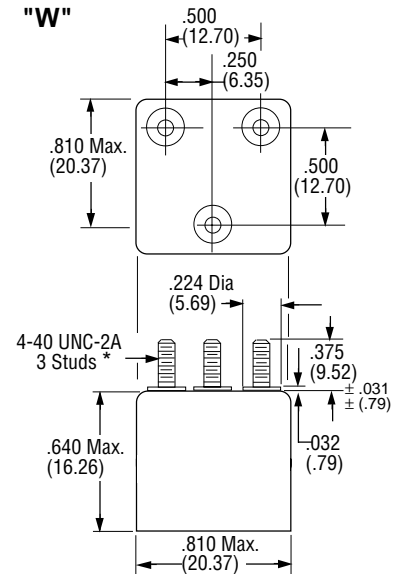

*Metric threads available. To specify use M in place of W



Tyco Electronics Mid-Range Military/Aerospace Relays

10 AMPERES, 3PDT

TERMINAL WIRING

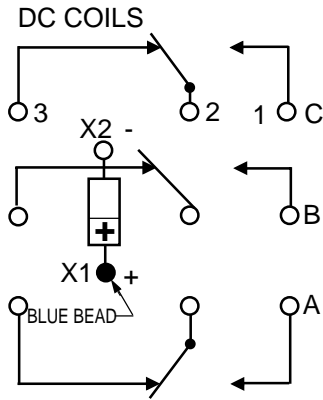

DC COILS WITH TRANSIENT SUPPRESSION

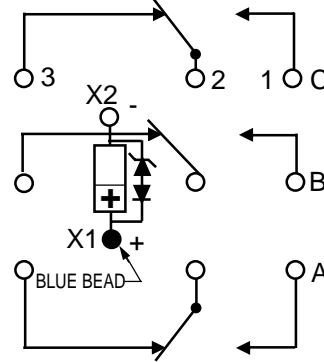

NOTE: Polarity must be observed with DC coil supply. Relay is polarized with a permanent magnet and will not operate or be damaged by reverse polarity.

Diodes used in transient suppression and in AC rectifier circuits have peak inverse voltage rating of 600 VDC minimum. Zener diodes have a minimum rating of 1 watt.

Terminal designations are for reference only and do not appear on the header.

TERMINAL LAYOUT

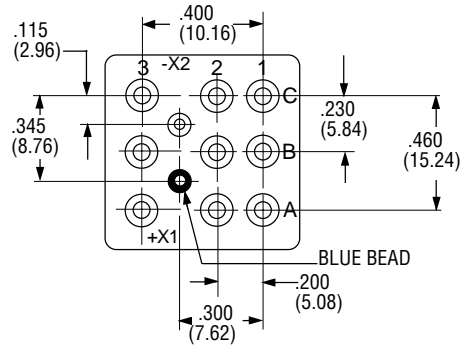

HOW TO ORDER

(EXAMPLE) _____ **FCB-310-A Y 4**

RELAY TYPE _____

TERMINALS (Socket Pins) _____

ENCLOSURE (With Flanges) _____

COIL (28 VDC With Transient Suppression). _____



Tyco Electronics Mid-Range Military/Aerospace Relays

5 AMPERES, 4PDT



- HERMETICALLY SEALED
- ALL WELDED CONSTRUCTION
- BALANCED FORCE
- PERMANENT MAGNET DRIVE
- CONTACTS RATED LOW LEVEL TO 5 AMPS
- 28 VDC AND 115/200 VAC 400 Hz 3 PHASE
- WEIGHT .93 OUNCES MAX. (26.4 GRAMS)

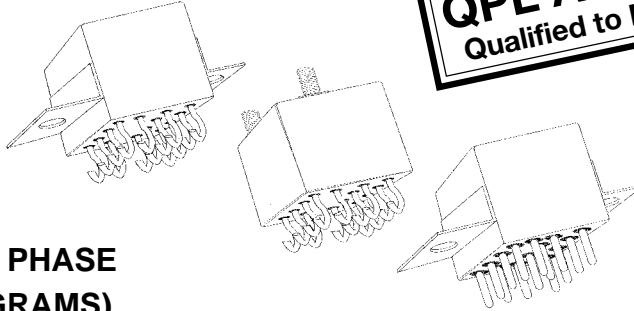

The Series FCB-405 relay is a polarized single-side stable design, where the flux from a permanent magnet provides the armature holding force in the deactivated state, and its flux path is switched and combined with the coil flux in the operated state. This results in appreciably increased contact pressure in both states over that of a spring return nonpolar design. We also manufacture other versions of this relay:

- FCB-205:** 5 AMP DPDT RELAY
- FCB-310:** 10 AMP 3PDT RELAY

CONTACT RATING-AMPERES

Ratings Are Continuous Duty

TYPE OF LOAD	LIFE (MIN.) CYCLES X 10 ³	28 VDC	115VAC 400HZ	115/200VAC 400Hz-3Ø
Resistive	100	5	5	5
Inductive	20	3	5	5
Motor	100	2	3	3
Lamp	100	1	1	1

Low Level Switching Capability: With contacts operating a load of 10 to 50 microamperes at 10 to 50 millivolts, the contact resistance miss detection level shall be 100 ohms max. Cycling rate is 1 to 12 per second, for 100,000 operations.

OVERLOAD CURRENT 20 AMPS DC, 30 AMPS 400HZ
RUPTURE CURRENT 25 AMPS DC, 40 AMPS 400HZ
CONTACT MAKE BOUNCE 1.0 MILLISECOND AT NOMINAL VOLTAGE
MAX. CONTACT DROP AT 5 AMPS: INITIAL 0.100 VOLTS.
END OF LIFE 0.125 VOLTS



Tyco Electronics Mid-Range Military/Aerospace Relays

5 AMPERES, 4PDT

COIL DATA

COIL CODE	NOMINAL VOLTAGES	FREQ. HZ	DC RES. (B)	OVER TEMPERATURE RANGE		
				PICKUP OR BELOW VOLTS	DROPOUT OR ABOVE VOLTS	MUST HOLD VOLTAGE (C)
1	6	DC	25 Ω	4.5	0.3	2.5
2	12	DC	100 Ω	9.0	0.75	4.5
3	28	DC	400 Ω	18.0	1.5	7.0
4 (A)	28	DC	400 Ω	18.0	1.5	7.0
5	48	DC	1275 Ω	36.0	2.5	14.0

- A. CODE 4 COILS HAVE BACK EMF SUPPRESSION TO 42 VOLTS MAX. D. MAX. OVER-VOLTAGE: 6 & 12 VDC COILS 120% OF NOMINAL; ALL OTHERS 110% OF NOMINAL.
- B. DC COIL RESISTANCE ± 10% AT 25°C;
- C. RELAY WILL STAY IN PICKED-UP STATE DOWN TO MUST HOLD VOLTAGES SHOWN. NOTE: Only DC Coil Models are QPL Approved.

GENERAL SPECIFICATIONS

TEMPERATURE RATING:		-70°C TO + 125°C
ALTITUDE:		300,000 FEET
SHOCK:*	Z, & Y ENCLOSURES	200 g FOR 6 mS
	W, X & M ENCLOSURES	100 g FOR 6 mS
	T ENCLOSURE (IN TRACK)	50 g FOR 11 mS
VIBRATION, SINUSOIDAL:*	Z, & Y ENCLOSURES	30 g 70-3000Hz
	W, X & M ENCLOSURES	20 g 70-3000Hz
	T ENCLOSURE (IN TRACK)	20 g 500-3000 Hz
VIBRATION, RANDOM: *	Z, & Y ENCLOSURES	0.4 g ² /Hz 50-2000Hz
	T, W, X & M ENCLOSURES	0.2 g ² /Hz 50-2000Hz
DIELECTRIC STRENGTH AT SEA LEVEL:	ALL CIRCUITS TO GROUND AND CIRCUIT TO CIRCUIT.	1000 V rms
	COIL TO GROUND	1000 V rms
DIELECTRIC STRENGTH AT 80,000 FEET:		250 V rms
INSULATION RESISTANCE:	INITIAL (500 VDC)	100 MΩ MINIMUM
	AFTER LIFE OR ENVIRONMENTAL TESTS	50 MΩ MINIMUM
OPERATE TIME AT NOMINAL VOLTAGE:		6 ms OR LESS
RELEASE TIME AT NOMINAL VOLTAGE:		6 ms OR LESS

* Max. contact opening under vibration or shock 10 microseconds



Tyco Electronics Mid-Range Military/Aerospace Relays

5 AMPERES, 4PDT

Below are shown the standard terminal types and the enclosures available. Specify the assembly as indicated under How To Order. Dimensions are shown in inches $\pm .010$ and (Millimeters $\pm .25$).

TERMINALS

CODE "A"

Socket Pins - All DC Coils

PIN TERMINALS ARE GOLD PLATED

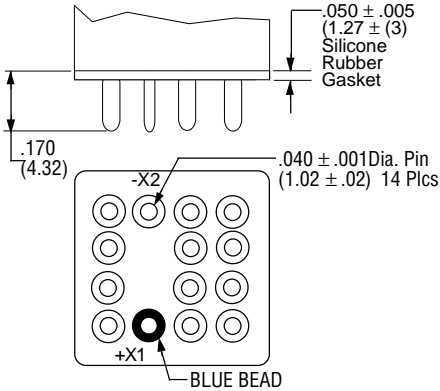

CODE "B"

Solder Pin Terminals

PIN TERMINALS TIN/LEAD PLATED

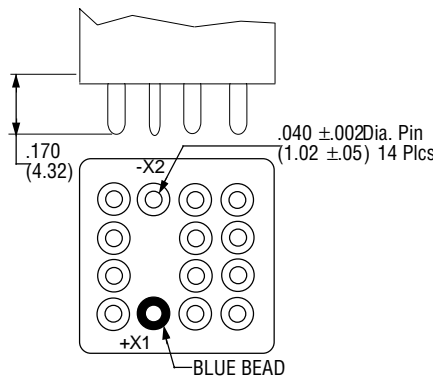

CODE "C"

Solder Hook Terminals

HOOK TERMINALS TIN/LEAD PLATED

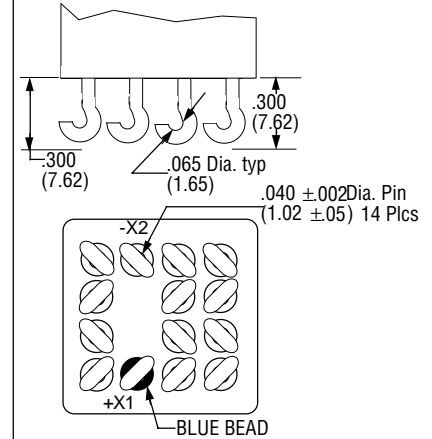

CODE "T"

M83536/6-025
(REFERENCE ONLY)

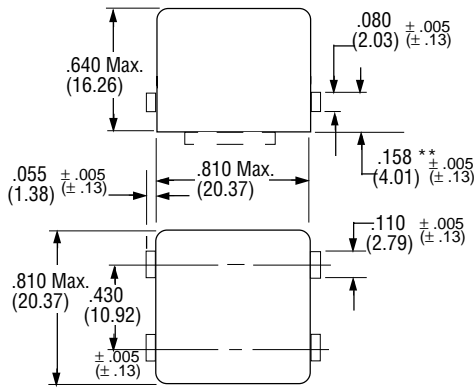

** Measured from surface of header

ENCLOSURES

All Enclosures have cupro-Nickel cans bright acid tin/lead plated after assembly to terminal headers.

Dimensions: Inches $\pm .010$ (mm $\pm .25$)

Code "T" used only with track-mounted Sockets. Requires code "A" pin terminals. Gasket is included in the socket assembly.

CODE "Z"

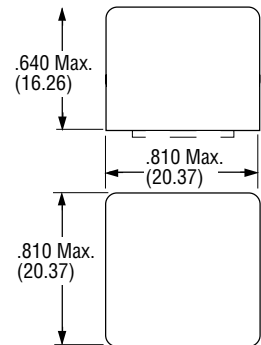

CODE "X"

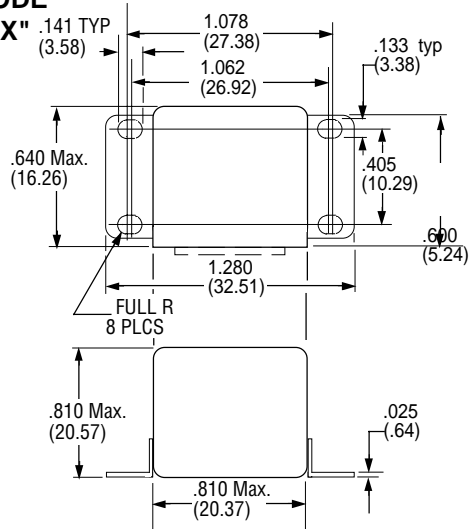

CODE "Y"

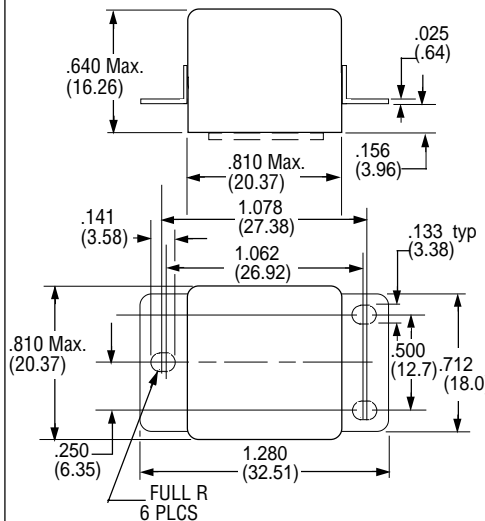

CODE "W"

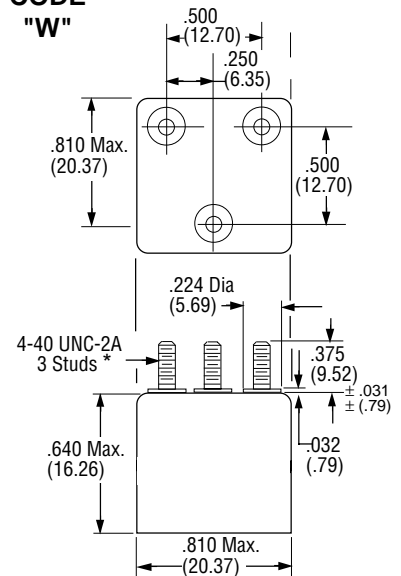

*Metric threads available, To specify use \square in place of \square



Tyco Electronics Mid-Range Military/Aerospace Relays

5 AMPERES, 4PDT

TERMINAL WIRING

DC COILS

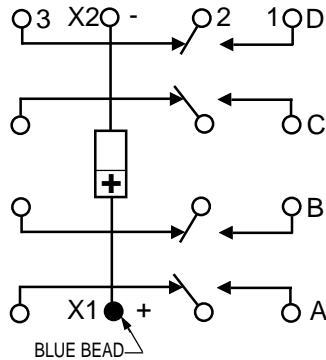

DC COILS WITH TRANSIENT SUPPRESSION

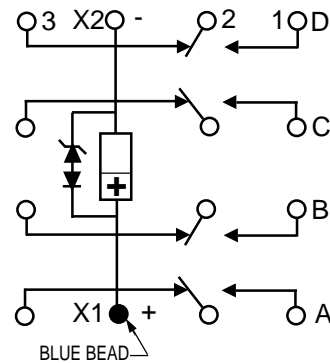

NOTE: Polarity must be observed with DC coil supply. Relay is polarized with a permanent magnet and will not operate or be damaged by reverse polarity.

Diodes used in transient suppression and in AC rectifier circuits have peak inverse voltage rating of 600 VDC minimum. Zener diodes have a minimum rating of 1 watt.

Terminal designations are for reference only and do not appear on the header.

TERMINAL LAYOUT

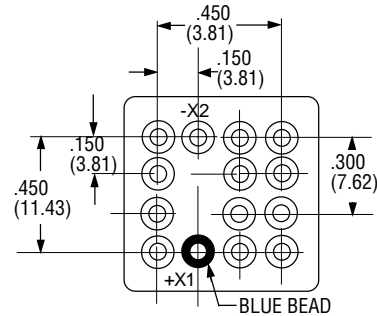

HOW TO ORDER

(EXAMPLE) _____ **FCB-405-A Y 4**

RELAY TYPE _____

TERMINALS (Socket Pins) _____

ENCLOSURE (With Flanges) _____

COIL (28 VDC With Transient Suppression). _____

NOTE: Only DC coil models are QPL Approved



Mid-Range Military/Aerospace Relays

Section 3

Cross Reference Guide & Suggested Practices



Tyco Electronics Mid-Range Military/Aerospace Relays

CROSS REFERENCE GUIDE

Current Mil-Spec Part Number to Tyco Electronics Part Number Arranged Alphanumerically by Mil-Spec Part Number

Current Mil-Spec Part Number	Tyco Electronics QPL Part Number	Catalog Equivalent (not QPL) Part Number	Current Mil-Spec Part Number	Tyco Electronics QPL Part Number	Catalog Equivalent (not QPL) Part Number
M6106/19 - 003	FCA-125-3	FCA-125-CY3	M83536/1 - 027M	FCB-205-0127M	FCB-205-HX3
M6106/19 - 004	FCA-125-4	FCA-125-AY3	M83536/1 - 028M	FCB-205-0128M	FCB-205-BZ5
M6106/19 - 005	FCA-125-5	FCA-125-BY3	M83536/1 - 029M	FCB-205-0129M	FCB-205-CZ5
M6106/19 - 006	FCA-125-6	FCA-125-CY3	M83536/1 - 030M	FCB-205-0130M	FCB-205-AZ5
M6106/19 - 007	FCA-125-7	FCA-125-AY3	M83536/1 - 031M	FCB-205-0131M	FCB-205-BY5
M6106/19 - 008	FCA-125-8	FCA-125-BX3	M83536/1 - 032M	FCB-205-0132M	FCB-205-CY5
M6106/19 - 009	FCA-125-9	FCA-125-CX3	M83536/1 - 033M	FCB-205-0133M	FCB-205-AY5
M6106/19 - 010	FCA-125-10	FCA-125-BY3	M83536/1 - 034M	FCB-205-0134M	FCB-205-BX5
M6106/19 - 011	FCA-125-11	FCA-125-CY3	M83536/1 - 035M	FCB-205-0135M	FCB-205-CX5
M6106/19 - 012	FCA-125-12	FCA-125-AY3	M83536/1 - 036M	FCB-205-0136M	FCB-205-AX5
M6106/19 - 013	FCA-125-13	FCA-125-BX3	M83536/2 - 001M	FCB-205-0201M	FCB-205-BZ1 w/ diode
M6106/19 - 014	FCA-125-14	FCA-125-CX3	M83536/2 - 002M	FCB-205-0202M	FCB-205-CZ1 w/ diode
M6106/19 - 015	FCA-125-15	FCA-125-BY4	M83536/2 - 003M	FCB-205-0203M	FCB-205-AZ1 w/ diode
M6106/19 - 016	FCA-125-16	FCA-125-CY4	M83536/2 - 004M	FCB-205-0204M	FCB-205-BY1 w/ diode
M6106/19 - 017	FCA-125-17	FCA-125-AY4	M83536/2 - 005M	FCB-205-0205M	FCB-205-CY1 w/ diode
M6106/19 - 018	FCA-125-18	FCA-125-BX4	M83536/2 - 006M	FCB-205-0206M	FCB-205-AY1 w/ diode
M6106/19 - 019	FCA-125-19	FCA-125-CX4	M83536/2 - 007M	FCB-205-0207M	FCB-205-BX1 w/ diode
M6106/19 - 020	FCA-125-20	FCA-125-BY4	M83536/2 - 008M	FCB-205-0208M	FCB-205-CX1 w/ diode
M6106/19 - 021	FCA-125-21	FCA-125-CY4	M83536/2 - 009M	FCB-205-0209M	FCB-205-AZ1 w/ diode
M6106/19 - 022	FCA-125-22	FCA-125-AY4	M83536/2 - 010M	FCB-205-0210M	FCB-205-BX2 w/ diode
M6106/19 - 023	FCA-125-23	FCA-125-BX4	M83536/2 - 011M	FCB-205-0211M	FCB-205-CZ2 w/ diode
M6106/19 - 024	FCA-125-24	FCA-125-CX4	M83536/2 - 012M	FCB-205-0212M	FCB-205-AZ2 w/ diode
M6106/19 - 025	FCA-125-25	FCA-125-CX3	M83536/2 - 013M	FCB-205-0213M	FCB-205-BY2 w/ diode
M83536/1 - 001M	FCB-205-0101M	FCB-205-BZ1	M83536/2 - 014M	FCB-205-0214M	FCB-205-CY2 w/ diode
M83536/1 - 002M	FCB-205-0102M	FCB-205-CZ1	M83536/2 - 015M	FCB-205-0215M	FCB-205-AY2 w/ diode
M83536/1 - 003M	FCB-205-0103M	FCB-205-AZ1	M83536/2 - 016M	FCB-205-0216M	FCB-205-BX2 w/ diode
M83536/1 - 004M	FCB-205-0104M	FCB-205-BY1	M83536/2 - 017M	FCB-205-0217M	FCB-205-CX2 w/ diode
M83536/1 - 005M	FCB-205-0105M	FCB-205-CY1	M83536/2 - 018M	FCB-205-0218M	FCB-205-HX2 w/ diode
M83536/1 - 006M	FCB-205-0106M	FCB-205-AY1	M83536/2 - 019M	FCB-205-0219M	FCB-205-BZ4
M83536/1 - 007M	FCB-205-0107M	FCB-205-BX1	M83536/2 - 020M	FCB-205-0220M	FCB-205-CZ4
M83536/1 - 008M	FCB-205-0108M	FCB-205-CX1	M83536/2 - 021M	FCB-205-0221M	FCB-205-AZ4
M83536/1 - 009M	FCB-205-0109M	FCB-205-AX1	M83536/2 - 022M	FCB-205-0222M	FCB-205-BY4
M83536/1 - 010M	FCB-205-0110M	FCB-205-BZ2	M83536/2 - 023M	FCB-205-0223M	FCB-205-CY4
M83536/1 - 011M	FCB-205-0111M	FCB-205-CZ2	M83536/2 - 024M	FCB-205-0224M	FCB-205-AY4
M83536/1 - 012M	FCB-205-0112M	FCB-205-AZ2	M83536/2 - 025M	FCB-205-0225M	FCB-205-BX4
M83536/1 - 013M	FCB-205-0113M	FCB-205-BY2	M83536/2 - 026M	FCB-205-0226M	FCB-205-CX4
M83536/1 - 014M	FCB-205-0114M	FCB-205-CY2	M83536/2 - 027M	FCB-205-0227M	FCB-205-HX4
M83536/1 - 015M	FCB-205-0115M	FCB-205-AY2	M83536/2 - 028M	FCB-205-0228M	FCB-205-AT4
M83536/1 - 016M	FCB-205-0116M	FCB-205-BX2	M83536/2 - 030M	FCB-205-0230M	FCB-205-BZ5 w/ diode
M83536/1 - 017M	FCB-205-0117M	FCB-205-HX2	M83536/2 - 031M	FCB-205-0231M	FCB-205-CZ5 w/ diode
M83536/1 - 019M	FCB-205-0119M	FCB-205-BZ3	M83536/2 - 032M	FCB-205-0232M	FCB-205-AZ5 w/ diode
M83536/1 - 020M	FCB-205-0120M	FCB-205-CZ3	M83536/2 - 033M	FCB-205-0233M	FCB-205-BY5 w/ diode
M83536/1 - 021M	FCB-205-0121M	FCB-205-AZ3	M83536/2 - 034M	FCB-205-0234M	FCB-205-CY5 w/ diode
M83536/1 - 022M	FCB-205-0122M	FCB-205-BY3	M83536/2 - 035M	FCB-205-0235M	FCB-205-AY5 w/ diode
M83536/1 - 023M	FCB-205-0123M	FCB-205-CY3	M83536/2 - 036M	FCB-205-0236M	FCB-205-BX5 w/ diode
M83536/1 - 024M	FCB-205-0124M	FCB-205-AY3	M83536/2 - 037M	FCB-205-0237M	FCB-205-CX5 w/ diode
M83536/1 - 025M	FCB-205-0125M	FCB-205-BX3	M83536/2 - 038M	FCB-205-0238M	FCB-205-HX5 w/ diode
M83536/1 - 026M	FCB-205-0126M	FCB-205-CX3	M83536/5 - 012M	FCB-405-0512M	FCB-405-BY2



Tyco Electronics Mid-Range Military/Aerospace Relays

CROSS REFERENCE GUIDE

Current Mil-Spec Part Number to Tyco Electronics Part Number (continued)

Arranged Alphanumerically by Mil-Spec Part Number

Current Mil-Spec Part Number	Tyco Electronics QPL Part Number	Catalog Equivalent (not QPL) Part Number	Current Mil-Spec Part Number	Tyco Electronics QPL Part Number	Catalog Equivalent (not QPL) Part Number
M83536/5 - 013M	FCB-405-0513M	FCB-405-CY2	M83536/9 - 024M	FCA-210-0924M	FCA-210-AV3
M83536/5 - 014M	FCB-405-0514M	FCB-405-AY2	M83536/9 - 025M	FCA-210-0925M	FCA-210-BX3
M83536/5 - 015M	FCB-405-0515M	FCB-405-BX2	M83536/9 - 026M	FCA-210-0926M	FCA-210-CX3
M83536/5 - 016M	FCB-405-0516M	FCB-405-CX2	M83536/9 - 027M	FCA-210-0927M	FCA-210-HX3
M83536/5 - 017M	FCB-405-0517M	FCB-405-BZ3	M83536/9 - 030M	FCA-210-0930M	FCA-210-BZ5
M83536/5 - 018M	FCB-405-0518M	FCB-405-CZ3	M83536/9 - 031M	FCA-210-0931M	FCA-210-CZ5
M83536/5 - 019M	FCB-405-0519M	FCB-405-AZ3	M83536/9 - 032M	FCA-210-0932M	FCA-210-AZ5
M83536/5 - 020M	FCB-405-0520M	FCB-405-BY3	M83536/9 - 033M	FCA-210-0933M	FCA-210-BY5
M83536/5 - 021M	FCB-405-0521M	FCB-405-CY3	M83536/9 - 034M	FCA-210-0934M	FCA-210-CY5
M83536/5 - 022M	FCB-405-0522M	FCB-405-AY3	M83536/9 - 035M	FCA-210-0935M	FCA-210-AY5
M83536/5 - 023M	FCB-405-0523M	FCB-405-BX3	M83536/9 - 036M	FCA-210-0936M	FCA-210-BX5
M83536/5 - 024M	FCB-405-0524M	FCB-405-CX3	M83536/9 - 037M	FCA-210-0937M	FCA-210-CX5
M83536/6 - 012M	FCB-405-0612M	Not Available	M83536/9 - 038M	FCA-210-0938M	FCA-210-HX5
M83536/6 - 013M	FCB-405-0613M	Not Available	M83536/10 - 001M	FCA-210-1001M	FCA-210-BZ1 w/ diode
M83536/6 - 014M	FCB-405-0614M	Not Available	M83536/10 - 002M	FCA-210-1002M	FCA-210-CZ1 w/ diode
M83536/6 - 015M	FCB-405-0615M	Not Available	M83536/10 - 003M	FCA-210-1003M	FCA-210-AZ1 w/ diode
M83536/6 - 016M	FCB-405-0616M	Not Available	M83536/10 - 004M	FCA-210-1004M	FCA-210-BY1 w/ diode
M83536/6 - 017M	FCB-405-0617M	FCB-405-BZ4	M83536/10 - 005M	FCA-210-1005M	FCA-210-CY1 w/ diode
M83536/6 - 018M	FCB-405-0618M	FCB-405-CZ4	M83536/10 - 006M	FCA-210-1006M	FCA-210-AY1 w/ diode
M83536/6 - 019M	FCB-405-0619M	FCB-405-AZ4	M83536/10 - 007M	FCA-210-1007M	FCA-210-BX1 w/ diode
M83536/6 - 020M	FCB-405-0620M	FCB-405-BY4	M83536/10 - 008M	FCA-210-1008M	FCA-210-CX1 w/ diode
M83536/6 - 021M	FCB-405-0621M	FCB-405-CY4	M83536/10 - 009M	FCA-210-1009M	FCA-210-HX1 w/ diode
M83536/6 - 022M	FCB-405-0622M	FCB-405-AY4	M83536/10 - 010M	FCA-210-1010M	FCA-210-BZ2 w/ diode
M83536/6 - 023M	FCB-405-0623M	FCB-405-BX4	M83536/10 - 011M	FCA-210-1011M	FCA-210-CZ2 w/ diode
M83536/6 - 024M	FCB-405-0624M	FCB-405-CX4	M83536/10 - 012M	FCA-210-1012M	FCA-210-AZ2 w/ diode
M83536/6 - 025M	FCB-405-0625M	FCB-405-AT4	M83536/10 - 013M	FCA-210-1013M	FCA-210-BY2 w/ diode
M83536/9 - 001M	FCA-210-0901M	FCA-210-BZ1	M83536/10 - 014M	FCA-210-1014M	FCA-210-CY2 w/ diode
M83536/9 - 002M	FCA-210-0902M	FCA-210-CZ1	M83536/10 - 015M	FCA-210-1015M	FCA-210-AY2 w/ diode
M83536/9 - 003M	FCA-210-0903M	FCA-210-AZ1	M83536/10 - 016M	FCA-210-1016M	FCA-210-BX2 w/ diode
M83536/9 - 004M	FCA-210-0904M	FCA-210-BY1	M83536/10 - 017M	FCA-210-1017M	FCA-210-CX2 w/ diode
M83536/9 - 005M	FCA-210-0905M	FCA-210-CY1	M83536/10 - 018M	FCA-210-1018M	FCA-210-HX2 w/ diode
M83536/9 - 006M	FCA-210-0906M	FCA-210-AY1	M83536/10 - 019M	FCA-210-1019M	FCA-210-BZ4
M83536/9 - 007M	FCA-210-0907M	FCA-210-BX1	M83536/10 - 020M	FCA-210-1020M	FCA-210-CZ4
M83536/9 - 008M	FCA-210-0908M	FCA-210-CX1	M83536/10 - 022M	FCA-210-1022M	FCA-210-BY4
M83536/9 - 009M	FCA-210-0909M	FCA-210-HX1	M83536/10 - 023M	FCA-210-1023M	FCA-210-CY4
M83536/9 - 010M	FCA-210-0910M	FCA-210-BZ2	M83536/10 - 024M	FCA-210-1024M	FCA-210-AY4
M83536/9 - 011M	FCA-210-0911M	FCA-210-CZ2	M83536/10 - 025M	FCA-210-1025M	FCA-210-BX4
M83536/9 - 012M	FCA-210-0912M	FCA-210-AZ2	M83536/10 - 026M	FCA-210-1026M	FCA-210-CX4
M83536/9 - 013M	FCA-210-0913M	FCA-210-BY2	M83536/10 - 027M	FCA-210-1027M	FCA-210-HX4
M83536/9 - 014M	FCA-210-0914M	FCA-210-CY2	M83536/10 - 029M	FCA-210-1029M	FCA-210-BZ5 w/ diode
M83536/9 - 015M	FCA-210-0915M	FCA-210-AY2	M83536/10 - 030M	FCA-210-1030M	FCA-210-CZ5 w/ diode
M83536/9 - 016M	FCA-210-0916M	FCA-210-BX2	M83536/10 - 031M	FCA-210-1031M	FCA-210-AZ5 w/ diode
M83536/9 - 017M	FCA-210-0917M	FCA-210-CX2	M83536/10 - 032M	FCA-210-1032M	FCA-210-BY5 w/ diode
M83536/9 - 018M	FCA-210-0918M	FCA-210-HX2	M83536/10 - 033M	FCA-210-1033M	FCA-210-CY5 w/ diode
M83536/9 - 019M	FCA-210-0919M	FCA-210-BZ3	M83536/10 - 034M	FCA-210-1034M	FCA-210-AY5 w/ diode
M83536/9 - 020M	FCA-210-0920M	FCA-210-CZ3	M83536/10 - 035M	FCA-210-1035M	FCA-210-BX5 w/ diode
M83536/9 - 022M	FCA-210-0922M	FCA-210-BY3	M83536/10 - 036M	FCA-210-1036M	FCA-210-CX5 w/ diode
M83536/9 - 023M	FCA-210-0923M	FCA-210-CY3	M83536/10 - 037M	FCA-210-1037M	FCA-210-HX5 w/ diode



Tyco Electronics Mid-Range Military/Aerospace Relays

CROSS REFERENCE GUIDE

Current Mil-Spec Part Number to Tyco Electronics Part Number (continued)

Arranged Alphanumerically by Mil-Spec Part Number

Current Mil-Spec Part Number	Tyco Electronics QPL Part Number	Catalog Equivalent (not QPL) Part Number	Current Mil-Spec Part Number	Tyco Electronics QPL Part Number	Catalog Equivalent (not QPL) Part Number
M83536/15 - 001M	FCA-410-1501M	FCA-410-BZ1	M83536/16 - 020M	FCA-410-1620M	FCA-410-BY4
M83536/15 - 002M	FCA-410-1502M	FCA-410-CZ1	M83536/16 - 021M	FCA-410-1621M	FCA-410-CY4
M83536/15 - 003M	FCA-410-1503M	FCA-410-AZ1	M83536/16 - 022M	FCA-410-1622M	FCA-410-AY4
M83536/15 - 004M	FCA-410-1504M	FCA-410-BY1	M83536/16 - 024M	FCA-410-1624M	FCA-410-CX4
M83536/15 - 005M	FCA-410-1505M	FCA-410-CY1	M83536/16 - 026M	FCA-410-1626M	FCA-410-BZ5 w/ diode
M83536/15 - 006M	FCA-410-1506M	FCA-410-AY1	M83536/16 - 027M	FCA-410-1627M	FCA-410-CZ5 w/ diode
M83536/15 - 007M	FCA-410-1507M	FCA-410-BX1	M83536/16 - 028M	FCA-410-1628M	FCA-410-AZ5 w/ diode
M83536/15 - 008M	FCA-410-1508M	FCA-410-CX1	M83536/16 - 029M	FCA-410-1629M	FCA-410-BY5 w/ diode
M83536/15 - 009M	FCA-410-1509M	FCA-410-BZ2	M83536/16 - 030M	FCA-410-1630M	FCA-410-CY5 w/ diode
M83536/15 - 010M	FCA-410-1510M	FCA-410-CZ2	M83536/16 - 031M	FCA-410-1631M	FCA-410-AY5 w/ diode
M83536/15 - 011M	FCA-410-1511M	FCA-410-AZ2	M83536/16 - 032M	FCA-410-1632M	FCA-410-BX5 w/ diode
M83536/15 - 012M	FCA-410-1512M	FCA-410-BY2	M83536/16 - 033M	FCA-410-1633M	FCA-410-CX5 w/ diode
M83536/15 - 013M	FCA-410-1513M	FCA-410-CY2	M83536/25 - 001L	FCA-610-2501L	FCA-610-CY3
M83536/15 - 014M	FCA-410-1514M	FCA-410-AY2	M83536/25 - 002L	FCA-610-2501L	FCA-610-AY3
M83536/15 - 015M	FCA-410-1515M	FCA-410-BX2	M83536/26 - 001L	FCA-610-2601L	FCA-610-CY4
M83536/15 - 016M	FCA-410-1516M	FCA-410-CX2	M83536/26 - 002L	FCA-610-2602L	FCA-610-AY4
M83536/15 - 017M	FCA-410-1517M	FCA-410-BZ3	M83536/32 - 001L	FCA-325-3201L	FCA-325-BY3
M83536/15 - 018M	FCA-410-1518M	FCA-410-CZ3	M83536/32 - 002L	FCA-325-3202L	FCA-325-CY3
M83536/15 - 020M	FCA-410-1520M	FCA-410-BY3	M83536/32 - 003L	FCA-325-3203L	FCA-325-AY3
M83536/15 - 021M	FCA-410-1521M	FCA-410-CY3	M83536/32 - 004L	FCA-325-3204L	FCA-325-BX3
M83536/15 - 022M	FCA-410-1522M	FCA-410-AY3	M83536/32 - 005L	FCA-325-3205L	FCA-325-CX3
M83536/15 - 024M	FCA-410-1524M	FCA-410-CX3	M83536/33 - 001L	FCA-325-3301L	FCA-325-BY4
M83536/15 - 025M	FCA-410-1525M	FCA-410-BZ5	M83536/33 - 001L	FCA-325-3301L	FCA-325-BY4
M83536/15 - 026M	FCA-410-1526M	FCA-410-CZ5	M83536/33 - 002L	FCA-325-3302L	FCA-325-CY4
M83536/15 - 027M	FCA-410-1527M	FCA-410-AZ5	M83536/33 - 003L	FCA-325-3303L	FCA-325-AY4
M83536/15 - 028M	FCA-410-1528M	FCA-410-BY5	M83536/33 - 004L	FCA-325-3304L	FCA-325-BX4
M83536/15 - 029M	FCA-410-1529M	FCA-410-CY5	M83536/33 - 005L	FCA-325-3305L	FCA-325-CX4
M83536/15 - 030M	FCA-410-1530M	FCA-410-AY5			
M83536/15 - 031M	FCA-410-1531M	FCA-410-BX5			
M83536/15 - 032M	FCA-410-1533M	FCA-410-CX5			
M83536/16 - 001M	FCA-410-1601M	FCA-410-BZ1 w/ diode			
M83536/16 - 002M	FCA-410-1602M	FCA-410-CZ1 w/ diode			
M83536/16 - 003M	FCA-410-1603M	FCA-410-AZ1 w/ diode			
M83536/16 - 004M	FCA-410-1604M	FCA-410-BY1 w/ diode			
M83536/16 - 005M	FCA-410-1605M	FCA-410-CY1 w/ diode			
M83536/16 - 006M	FCA-410-1606M	FCA-410-AY1 w/ diode			
M83536/16 - 007M	FCA-410-1607M	FCA-410-BX1 w/ diode			
M83536/16 - 008M	FCA-410-1608M	FCA-410-CX1 w/ diode			
M83536/16 - 009M	FCA-410-1609M	FCA-410-BZ2 w/ diode			
M83536/16 - 010M	FCA-410-1610M	FCA-410-CZ2 w/ diode			
M83536/16 - 011M	FCA-410-1611M	FCA-410-AZ2 w/ diode			
M83536/16 - 012M	FCA-410-1612M	FCA-410-BY2 w/ diode			
M83536/16 - 013M	FCA-410-1613M	FCA-410-CY2 w/ diode			
M83536/16 - 014M	FCA-410-1614M	FCA-410-AY2 w/ diode			
M83536/16 - 015M	FCA-410-1615M	FCA-410-BX2 w/ diode			
M83536/16 - 016M	FCA-410-1616M	FCA-410-CX2 w/ diode			
M83536/16 - 017M	FCA-410-1617M	FCA-410-BZ4			
M83536/16 - 018M	FCA-410-1618M	FCA-410-CZ4			



Tyco Electronics Mid-Range Military/Aerospace Relays

CROSS REFERENCE GUIDE

**Superceded Mil-Spec Part Number to Current Mil-Spec Part Number to
Tyco Electronics Part Number to Previous S-D Part Number
Arranged Alphanumerically by Superceded Mil-Spec Part Number**

Superceded Mil-Spec Part Number	Current Mil-Spec Part Number	Tyco Electronics QPL Part Number	Catalog Equivalent (not QPL) Part Number	Superceded S-D Part Number
M6106/1 - 001	M83536/10 - 028M	FCA-210-1028M	Not Available	FCA-210-31
M6106/1 - 002	M83536/11 - 012M	FCA-210-1112M	Not Available	FCA-210-33
M6106/1 - 003	M83536/10 - 028M	FCA-210-1028M	Not Available	FCA-210-32
M6106/2 - 001	M83536/16 - 025M	FCA-410-1625M	Not Available	FCA-410-31
M6106/2 - 002	M83536/17 - 010M	FCA-410-1710M	Not Available	FCA-410-33
M6106/2 - 003	M83536/16 - 025M	FCA-410-1625M	Not Available	FCA-410-34
M6106/8 - 001	M83536/25 - 001L	FCA-610-2501L	FCA-610-CY3	FCA-610-1
M6106/8 - 002	M83536/25 - 002L	FCA-610-2502L	FCA-610-AY3	FCA-610-2
M6106/8 - 003	M83536/27 - 001L	FCA-610-2701L	FCA-610-CY8	FCA-610-3
M6106/8 - 004	M83536/27 - 002L	FCA-610-2702L	FCA-610-DY8	FCA-610-4
M6106/8 - 005	M83536/25 - 001L	FCA-610-2501L	FCA-610-CY3	FCA-610-5
M6106/8 - 006	M83536/25 - 002L	FCA-610-2502L	FCA-610-AY3	FCA-610-6
M6106/8 - 007	M83536/27 - 001L	FCA-610-2701L	FCA-610-CY8	FCA-610-7
M6106/8 - 008	M83536/27 - 002L	FCA-610-2702L	FCA-610-DY8	FCA-610-8
M6106/8 - 009	M83536/26 - 001L	FCA-610-2601L	FCA-610-CY4	FCA-610-9
M6106/8 - 010	M83536/26 - 002L	FCA-610-2602L	FCA-610-AY4	FCA-610-10
M6106/8 - 011	M83536/26 - 001L	FCA-610-2601L	FCA-610-CY4	FCA-610-11
M6106/8 - 012	M83536/26 - 002L	FCA-610-2602L	FCA-610-AY4	FCA-610-12
M6106/8 - 013	M83536/25 - 001L	FCA-610-2501L	FCA-610-CY3	FCA-610-13
M6106/8 - 014	M83536/25 - 002L	FCA-610-2501L	FCA-610-AY3	FCA-610-14
M6106/19 - 003	M6106/19 - 003	FCA-125-3	FCA-125-CY3	FCA-125-3
M6106/19 - 004	M6106/19 - 004	FCA-125-4	FCA-125-AY3	FCA-125-4
M6106/19 - 005	M6106/19 - 005	FCA-125-5	FCA-125-BY3	FCA-125-5
M6106/19 - 006	M6106/19 - 006	FCA-125-6	FCA-125-CY3	FCA-125-6
M6106/19 - 007	M6106/19 - 007	FCA-125-7	FCA-125-AY3	FCA-125-7
M6106/19 - 008	M6106/19 - 008	FCA-125-8	FCA-125-BX3	FCA-125-8
M6106/19 - 009	M6106/19 - 009	FCA-125-9	FCA-125-CX3	FCA-125-9
M6106/19 - 010	M6106/19 - 010	FCA-125-10	FCA-125-BY3	FCA-125-10
M6106/19 - 011	M6106/19 - 011	FCA-125-11	FCA-125-CY3	FCA-125-11
M6106/19 - 012	M6106/19 - 012	FCA-125-12	FCA-125-AY3	FCA-125-12
M6106/19 - 013	M6106/19 - 013	FCA-125-13	FCA-125-BX3	FCA-125-13
M6106/19 - 014	M6106/19 - 014	FCA-125-14	FCA-125-CX3	FCA-125-14
M6106/19 - 015	M6106/19 - 015	FCA-125-15	FCA-125-BY4	FCA-125-15
M6106/19 - 016	M6106/19 - 016	FCA-125-16	FCA-125-CY4	FCA-125-16
M6106/19 - 017	M6106/19 - 017	FCA-125-17	FCA-125-AY4	FCA-125-17
M6106/19 - 018	M6106/19 - 018	FCA-125-18	FCA-125-BX4	FCA-125-18
M6106/19 - 019	M6106/19 - 019	FCA-125-19	FCA-125-CX4	FCA-125-19
M6106/19 - 020	M6106/19 - 020	FCA-125-20	FCA-125-BY4	FCA-125-20
M6106/19 - 021	M6106/19 - 021	FCA-125-21	FCA-125-CY4	FCA-125-21
M6106/19 - 022	M6106/19 - 022	FCA-125-22	FCA-125-AY4	FCA-125-22
M6106/19 - 023	M6106/19 - 023	FCA-125-23	FCA-125-BX4	FCA-125-23
M6106/19 - 024	M6106/19 - 024	FCA-125-24	FCA-125-CX4	FCA-125-24
M6106/19 - 025	M6106/19 - 025	FCA-125-25	FCA-125-CX3	FCA-125-25
M6106/21 - 003	M83536/2 - 028M	FCB-205-0228M	FCB-205-AT4	FCB-210-23X
M6106/22 - 003	M83536/6 - 025M	FCB-405-0625M	FCB-405-AT4	FCB-410-24X



Tyco Electronics Mid-Range Military/Aerospace Relays

CROSS REFERENCE GUIDE

Superseded Mil-Spec Part Number to Current Mil-Spec Part Number to Tyco Electronics Part Number to Previous S-D Part Number (continued)
Arranged Alphanumerically by Superseded Mil-Spec Part Number

Superseded Mil-Spec Part Number	Current Mil-Spec Part Number	Tyco Electronics QPL Part Number	Catalog Equivalent (not QPL) Part Number	Superseded S-D Part Number
M6106/24 - 003	M83536/22 - 025M	FCB-310-2225M	FCB-310-AT4	FCB-310-26U
M6106/27 - 001	M83536/1 - 019M	FCB-205-0119M	FCB-205-BX3	FCB-210-1
M6106/27 - 002	M83536/1 - 019M	FCB-205-0119M	FCB-205-BZ3	FCB-210-2X
M6106/27 - 003	M83536/2 - 019M	FCB-205-0219M	FCB-205-BZ4	FCB-210-3
M6106/27 - 004	M83536/2 - 019M	FCB-205-0219M	FCB-205-BZ4	FCB-210-4X
M6106/27 - 005	M83536/1 - 020M	FCB-205-0120M	FCB-205-CZ3	FCB-210-5
M6106/27 - 006	M83536/1 - 020M	FCB-205-0120M	FCB-205-CZ3	FCB-210-6X
M6106/27 - 007	M83536/2 - 020M	FCB-205-0220M	FCB-205-CZ4	FCB-210-7
M6106/27 - 008	M83536/2 - 020M	FCB-205-0220M	FCB-205-CZ4	FCB-210-8X
M6106/27 - 009	M83536/1 - 021M	FCB-205-0121M	FCB-205-AZ3	FCB-210-9
M6106/27 - 010	M83536/1 - 021M	FCB-205-0121M	FCB-205-AZ3	FCB-210-10X
M6106/27 - 011	M83536/2 - 021M	FCB-205-0221M	FCB-205-AZ4	FCB-210-11
M6106/27 - 012	M83536/2 - 021M	FCB-205-0221M	FCB-205-AZ4	FCB-210-12X
M6106/27 - 013	M83536/1 - 022M	FCB-205-0122M	FCB-205-BY3	FCB-210-13
M6106/27 - 014	M83536/1 - 022M	FCB-205-0122M	FCB-205-BY3	FCB-210-14X
M6106/27 - 015	M83536/2 - 022M	FCB-205-0222M	FCB-205-BY4	FCB-210-15
M6106/27 - 016	M83536/2 - 022M	FCB-205-0222M	FCB-205-BY4	FCB-210-16X
M6106/27 - 017	M83536/1 - 023M	FCB-205-0123M	FCB-205-CY3	FCB-210-17
M6106/27 - 018	M83536/1 - 023M	FCB-205-0123M	FCB-205-CY3	FCB-210-18X
M6106/27 - 019	M83536/2 - 023M	FCB-205-0223M	FCB-205-CY4	FCB-210-19
M6106/27 - 020	M83536/2 - 023M	FCB-205-0223M	FCB-205-CY4	FCB-210-20X
M6106/27 - 021	M83536/1 - 024M	FCB-205-0124M	FCB-205-AY3	FCB-210-42
M6106/27 - 022	M83536/1 - 024M	FCB-205-0124M	FCB-205-AY3	FCB-210-43X
M6106/27 - 023	M83536/2 - 024M	FCB-205-0224M	FCB-205-AY4	FCB-210-44
M6106/27 - 024	M83536/2 - 024M	FCB-205-0224M	FCB-205-AY4	FCB-210-45X
M6106/27 - 025	M83536/1 - 025M	FCB-205-0125M	FCB-205-BX3	FCB-210-46
M6106/27 - 026	M83536/1 - 025M	FCB-205-0125M	FCB-205-BX3	FCB-210-47X
M6106/27 - 027	M83536/2 - 025M	FCB-205-0225M	FCB-205-BX4	FCB-210-48
M6106/27 - 028	M83536/2 - 025M	FCB-205-0225M	FCB-205-BX4	FCB-210-49X
M6106/27 - 029	M83536/1 - 026M	FCB-205-0126M	FCB-205-CX3	FCB-210-50
M6106/27 - 030	M83536/1 - 026M	FCB-205-0126M	FCB-205-CX3	FCB-210-51X
M6106/27 - 031	M83536/2 - 026M	FCB-205-0226M	FCB-205-CX4	FCB-210-52
M6106/27 - 032	M83536/2 - 026M	FCB-205-0226M	FCB-205-CX4	FCB-210-53X
M6106/27 - 037	M83536/1 - 027M	FCB-205-0127M	FCB-205-HX3	FCB-210-90
M6106/27 - 038	M83536/1 - 027M	FCB-205-0127M	FCB-205-HX3	FCB-210-91X
M6106/27 - 039	M83536/2 - 027M	FCB-205-0227M	FCB-205-HX4	FCB-210-92
M6106/27 - 040	M83536/2 - 027M	FCB-205-0227M	FCB-205-HX4	FCB-210-93X
M6106/28 - 001	M83536/5 - 017M	FCB-405-0517M	FCB-405-BZ3	FCB-410-1
M6106/28 - 002	M83536/5 - 017M	FCB-405-0517M	FCB-405-BZ3	FCB-410-2X
M6106/28 - 003	M83536/6 - 017M	FCB-405-0617M	FCB-405-BZ4	FCB-410-3
M6106/28 - 004	M83536/6 - 017M	FCB-405-0617M	FCB-405-BZ4	FCB-410-4X
M6106/28 - 005	M83536/5 - 018M	FCB-405-0518M	FCB-405-CZ3	FCB-410-5
M6106/28 - 006	M83536/5 - 018M	FCB-405-0518M	FCB-405-CZ3	FCB-410-6X
M6106/28 - 007	M83536/6 - 018M	FCB-405-0618M	FCB-405-CZ4	FCB-410-7
M6106/28 - 008	M83536/6 - 018M	FCB-405-0618M	FCB-405-CZ4	FCB-410-8X



Tyco Electronics Mid-Range Military/Aerospace Relays

CROSS REFERENCE GUIDE

Superseded Mil-Spec Part Number to Current Mil-Spec Part Number to Tyco Electronics Part Number to Previous S-D Part Number (continued)
Arranged Alphanumerically by Superseded Mil-Spec Part Number

Superseded Mil-Spec Part Number	Current Mil-Spec Part Number	Tyco Electronics QPL Part Number	Catalog Equivalent (not QPL) Part Number	Superseded S-D Part Number
M6106/28 - 023	M83536/6 - 022M	FCB-405-0622M	FCB-405-AY4	FCB-410-39
M6106/28 - 024	M83536/6 - 022M	FCB-405-0622M	FCB-405-AY4	FCB-410-40X
M6106/28 - 025	M83536/5 - 023M	FCB-405-0523M	FCB-405-BX3	FCB-410-41
M6106/28 - 026	M83536/5 - 023M	FCB-405-0523M	FCB-405-BX3	FCB-410-42X
M6106/28 - 027	M83536/6 - 023M	FCB-405-0623M	FCB-405-BX4	FCB-410-43
M6106/28 - 028	M83536/6 - 023M	FCB-405-0623M	FCB-405-BX4	FCB-410-44X
M6106/28 - 029	M83536/5 - 024M	FCB-405-0524M	FCB-405-CX3	FCB-410-45
M6106/28 - 030	M83536/5 - 024M	FCB-405-0524M	FCB-405-CX3	FCB-410-46X
M6106/28 - 031	M83536/6 - 024M	FCB-405-0624M	FCB-405-CX4	FCB-410-47
M6106/28 - 032	M83536/6 - 024M	FCB-405-0624M	FCB-405-CX4	FCB-410-48X
M6106/28 - 037	M83536/5 - 012M	FCB-405-0512M	FCB-405-BY2	FCB-410-53
M6106/28 - 038	M83536/6 - 012M	FCB-405-0612M	Not Available	FCB-410-54
M6106/28 - 039	M83536/5 - 013M	FCB-405-0513M	FCB-405-CY2	FCB-410-55
M6106/28 - 040	M83536/6 - 013M	FCB-405-0613M	Not Available	FCB-410-56
M6106/28 - 041	M83536/5 - 014M	FCB-405-0514M	FCB-405-AY2	FCB-410-57
M6106/28 - 042	M83536/6 - 014M	FCB-405-0614M	Not Available	FCB-410-58
M6106/28 - 043	M83536/5 - 015M	FCB-405-0515M	FCB-405-BX2	FCB-410-76
M6106/28 - 044	M83536/6 - 015M	FCB-405-0615M	Not Available	FCB-410-77
M6106/28 - 045	M83536/5 - 016M	FCB-405-0516M	FCB-405-CX2	FCB-410-78
M6106/28 - 046	M83536/6 - 016M	FCB-405-0616M	Not Available	FCB-410-79
MS27400- 1	Not Available	Not Available	FCA-410-CY3	FCA-410-1
MS27400- 2	Not Available	Not Available	FCA-410-AY3	FCA-410-2
MS27400- 3	Not Available	Not Available	FCA-410-CY8	FCA-410-3
MS27400- 4	Not Available	Not Available	FCA-410-CY8	FCA-410-4
MS27400- 5	M83536/15 - 021M	FCA-410-1521M	FCA-410-CY3	FCA-410-5X
MS27400- 6	M83536/15 - 022M	FCA-410-1522M	FCA-410-AY3	FCA-410-6X
MS27400- 7	M83536/17 - 001M	FCA-410-1701M	FCA-410-CY8	FCA-410-7X
MS27400- 8	M83536/17 - 002M	FCA-410-1702M	FCA-410-DY8	FCA-410-8X
MS27400- 9	M83536/15 - 021M	FCA-410-1521M	FCA-410-CY3	FCA-410-9
MS27400- 10	M83536/15 - 022M	FCA-410-1522M	FCA-410-AY3	FCA-410-10
MS27400- 11	M83536/17 - 001M	FCA-410-1701M	FCA-410-CY8	FCA-410-11
MS27400- 12	M83536/17 - 002M	FCA-410-1702M	FCA-410-DY8	FCA-410-12
MS27400- 17	M83536/16 - 022M	FCA-410-1622M	FCA-410-AY4	FCA-410-17
MS27400- 18	M83536/16 - 031M	FCA-410-1631M	Not Available	FCA-410-18
MS27400- 19	M83536/15 - 024M	FCA-410-1524M	FCA-410-CX3	FCA-410-19X
MS27400- 20	M83536/17 - 006M	FCA-410-1706M	FCA-410-CX8	FCA-410-CX8
MS27400- 21	M83536/15 - 024M	FCA-410-1524M	FCA-410-CX3	FCA-410- 41
MS27400- 22	M83536/17 - 006M	FCA-410-1706M	FCA-410-CX8	FCA-410- 42
MS27400- 23	M83536/16 - 021M	FCA-410-1621M	FCA-410-CY4	FCA-410- 43
MS27400- 24	M83536/16 - 024M	FCA-410-1624M	FCA-410-CX4	FCA-410- 44
MS27400- 26	M83536/17 - 004M	FCA-410-1704M	FCA-410-CY9	FCA-410- 46
MS27400- 27	M83536/17 - 007M	FCA-410-1707M	FCA-410-CX9	FCA-410- 47
MS27400- 28	M83536/17 - 005M	FCA-410-1705M	FCA-410-DY9	FCA-410- 48
MS27400- 29	M83536/16 - 021M	FCA-410-1621M	FCA-410-CY4	FCA-410- 49X
MS27400- 30	M83536/16 - 024M	FCA-410-1624M	FCA-410-CX4	FCA-410- 50X



Tyco Electronics Mid-Range Military/Aerospace Relays

CROSS REFERENCE GUIDE

Superceded Mil-Spec Part Number to Current Mil-Spec Part Number to Tyco Electronics Part Number to Previous S-D Part Number (continued)
Arranged Alphanumerically by Superceded Mil-Spec Part Number

Superceded Mil-Spec Part Number	Current Mil-Spec Part Number	Tyco Electronics QPL Part Number	Catalog Equivalent (not QPL) Part Number	Superceded S-D Part Number
MS27400-31	M83536/16 - 022M	FCA-410-1622M	FCA-410-AY4	FCA-410-51X
MS27400-32	M83536/17 - 004M	FCA-410-1704M	FCA-410-CY9	FCA-410-CY9
MS27400-33	M83536/17 - 007M	FCA-410-1707M	FCA-410-CX9	FCA-410-CX9
MS27400-34	M83536/17 - 005M	FCA-410-1705M	FCA-410-DY9	FCA-410-DY9
MS27400-35	M83536/15 - 020M	FCA-410-1520M	FCA-410-BY3	FCA-410-124
MS27400-36	M83536/15 - 020M	FCA-410-1520M	FCA-410-BY3	FCA-410-125X
MS27400-37	M83536/16 - 020M	FCA-410-1620M	FCA-410-BY4	FCA-410-126
MS27400-38	M83536/16 - 020M	FCA-410-1620M	FCA-410-BY4	FCA-410-127X
MS27400-39	M83536/17 - 003M	FCA-410-1703M	FCA-410-FY9	FCA-410-114
MS27400-40	M83536/15 - 018M	FCA-410-1518M	FCA-410-CZ3	FCA-410-220
MS27400-41	M83536/15 - 017M	FCA-410-1517M	FCA-410-BZ3	FCA-410-221
MS27400-42	M83536/16 - 018M	FCA-410-1618M	FCA-410-CZ4	FCA-410-222
MS27400-43	M83536/16 - 017M	FCA-410-1617M	FCA-410-BZ4	FCA-410-223
MS27400-44	M83536/15 - 018M	FCA-410-1518M	FCA-410-CZ3	FCA-410-224X
MS27400-45	M83536/15 - 017M	FCA-410-1517M	FCA-410-BZ3	FCA-410-225X
MS27400-46	M83536/16 - 018M	FCA-410-1618M	FCA-410-CZ4	FCA-410-226X
MS27400-47	M83536/16 - 017M	FCA-410-1617M	FCA-410-BZ4	FCA-410-227X
MS27400-48	M83536/17 - 009M	FCA-410-1709M	FCA-410-CZ9	FCA-410-228
MS27400-49	M83536/17 - 008M	FCA-410-1708M	FCA-410-FZ9	FCA-410-229
MS27400-50	M83536/17 - 009M	FCA-410-1709M	FCA-410-CZ9	FCA-410-CZ9
MS27400-51	M83536/17 - 008M	FCA-410-1708M	FCA-410-FZ9	FCA-410-FZ9
MS27401-10	M83536/9 - 009M	FCA-210-0929M	Not Available	FCA-210-10
MS27401-11	M83536/11 - 003M	FCA-210-1103M	Not Available	FCA-210-11
MS27401-12	M83536/11 - 004M	FCA-210-1104M	Not Available	FCA-210-12
MS27401-13	M83536/9 - 023M	FCA-210-0923M	FCA-210-CY3	FCA-210-13
MS27401-14	M83536/9 - 024M	FCA-210-0924M	FCA-210-AV3	FCA-210-14
MS27401-15	M83536/11 - 001M	FCA-210-1101M	FCA-210-CY8	FCA-210-15
MS27401-16	M83536/11 - 002M	FCA-210-1102M	FCA-210-DY8	FCA-210-16
MS27401-21	M83536/9 - 026M	FCA-210-0926M	FCA-210-CX3	FCA-210-41X
MS27401-22	M83536/11 - 008M	FCA-210-1108M	FCA-210-CX8	FCA-210-42X
MS27401-23	M83536/9 - 026M	FCA-210-0926M	FCA-210-CX3	FCA-210-43
MS27401-24	M83536/11 - 008M	FCA-210-1108M	FCA-210-CX8	FCA-210-44
MS27401-25	M83536/10 - 023M	FCA-210-1023M	FCA-210-CY4	FCA-210-45
MS27401-26	M83536/10 - 026M	FCA-210-1026M	FCA-210-CX4	FCA-210-46
MS27401-27	M83536/10 - 024M	FCA-210-1024M	FCA-210-AY4	FCA-210-47
MS27401-28	M83536/11 - 006M	FCA-210-1106M	FCA-210-CY9	FCA-210-48
MS27401-29	M83536/11 - 009M	FCA-210-1109M	FCA-210-CX9	FCA-210-49
MS27401-30	M83536/10 - 007M	FCA-210-1107M	FCA-210-DY9	FCA-210-50
MS27401-31	M83536/10 - 023M	FCA-210-1023M	FCA-210-CY4	FCA-210-51X
MS27401-32	M83536/10 - 026M	FCA-210-1026M	FCA-210-CX4	FCA-210-52X
MS27401-33	M83536/10 - 024M	FCA-210-1024M	FCA-210-AY4	FCA-210-53X
MS27401-34	M83536/11 - 007M	FCA-210-1107M	FCA-210-CY9	FCA-210-54X
MS27401-35	M83536/11 - 009M	FCA-210-1109M	FCA-210-CX9	FCA-210-55X
MS27401-36	M83536/11 - 007M	FCA-210-1107M	FCA-210-DY9	FCA-210-56X
MS27401-37	M83536/9 - 025M	FCA-210-0925M	FCA-210-BX3	FCA-210-57



Tyco Electronics Mid-Range Military/Aerospace Relays

CROSS REFERENCE GUIDE

Superceded Mil-Spec Part Number to Current Mil-Spec Part Number to Tyco Electronics Part Number to Previous S-D Part Number (continued)
Arranged Alphanumerically by Superceded Mil-Spec Part Number

Superceded Mil-Spec Part Number	Current Mil-Spec Part Number	Tyco Electronics QPL Part Number	Catalog Equivalent (not QPL) Part Number	Superceded S-D Part Number
MS27401 -38	M83536/9 - 025M	FCA-210-0925M	FCA-210-BX3	FCA-210-58X
MS27401 -39	M83536/10 - 025M	FCA-210-1025M	FCA-210-BX4	FCA-210-59
MS27401 -40	M83536/10 - 025M	FCA-210-1025M	FCA-210-BX4	FCA-210-60X
MS27401 -41	M83536/9 - 022M	FCA-210-0922M	FCA-210-BY3	FCA-210-119
MS27401 -42	M83536/9 -022M	FCA-210-0922M	FCA-210-BY3	FCA-210-120X
MS27401 -43	M83536/10 - 022M	FCA-210-1022M	FCA-210-BY4	FCA-210-121
MS27401 -44	M83536/10 - 022M	FCA-210-1022M	FCA-210-BY4	FCA-210-122X
MS27401 -45	M83536/11 - 005M	FCA-210-1105M	FCA-210-FY9	FCA-210-123
MS27401 -46	M83536/9 - 020M	FCA-210-0920M	FCA-210-CZ3	FCA-210-220
MS27401 -47	M83536/9 - 019M	FCA-210-0919M	FCA-210-BZ3	FCA-210-221
MS27401 -48	M83536/10 -020M	FCA-210-1020M	FCA-210-CZ4	FCA-210-222
MS27401 -49	M83536/10 - 019M	FCA-210-1019M	FCA-210-BZ4	FCA-210-223
MS27401 -5	M83536/9 - 023M	FCA-210-0923M	FCA-210-CY3	FCA-210-5X
MS27401 -50	M83536/9 - 020M	FCA-210-0920M	FCA-210-CZ3	FCA-210-224X
MS27401 -51	M83536/9 - 019M	FCA-210-0919M	FCA-210-BZ3	FCA-210-225X
MS27401 -52	M83536/10 - 020M	FCA-210-1020M	FCA-210-CZ4	FCA-210-226X
MS27401 -53	M83536/10 - 019M	FCA-210-1019M	FCA-210-BZ4	FCA-210-227X
MS27401 -54	M83536/11 - 011M	FCA-210-1111M	FCA-210-CZ9	FCA-210-228
MS27401 -55	M83536/11 - 010M	FCA-210-1110M	FCA-210-ZZ9	FCA-210-229
MS27401 -56	M83536/11 -011M	FCA-210-1111M	FCA-210-CZ9	FCA-210-230
MS27401 -57	M83536/11 - 010M	FCA-210-1110M	FCA-210-FZ9	FCA-210-231X
MS27401 -58	M83536/9 - 027M	FCA-210-0927M	FCA-210-HX3	FCA-210-321X
MS27401 -59	M83536/10 - 027M	FCA-210-1027M	FCA-210-HX4	FCA-210-332X
MS27401 -6	M83536/9 - 024M	FCA-210-0924M	FCA-210-AY3	FCA-210-6X
MS27401 -7	M83536/11 - 001M	FCA-210-1101M	FCA-210-CY8	FCA-210-7X
MS27401 -8	M83536/11 - 002M	FCA-210-1102M	FCA-210-DY8	FCA-210-8X
MS27401 -9	M83536/9 - 008M	FCA-210-0928M	Not Available	FCA-210-9
MS27743- 1	M83536/32-002L	FCA-325-3202L	FCA-325-CY3	FCA-325-1
MS27743- 2	M83536/32-003L	FCA-325-3203L	FCA-325-AY3	FCA-325-2
MS27743- 3	M83536/32-005L	FCA-325-3205L	FCA-325-CX3	FCA-325-3
MS27743- 4	M83536/32-002L	FCA-325-3202L	FCA-325-CY3	FCA-325-4
MS27743- 5	M83536/32-005L	FCA-325-3205L	FCA-325-CX3	FCA-325-5
MS27743- 6	M83536/32-003L	FCA-325-3203L	FCA-325-AY3	FCA-325-6
MS27743- 7	No QPL for AC Coils	Catalog Only	FCA-325-CY8	FCA-325-7
MS27743- 8	No QPL for AC Coils	Catalog Only	FCA-325-CX8	FCA-325-8
MS27743- 9	No QPL for AC Coils	Catalog Only	FCA-325-AV8	FCA-325-9
MS27743- 10	M83536/32-002L	FCA-325-3202L	FCA-325-CY3	FCA-325-10
MS27743- 11	M83536/32-005L	FCA-325-3205L	FCA-325-CX3	FCA-325-11
MS27743- 12	M83536/32-003L	FCA-325-3203L	FCA-325-AY3	FCA-325-12
MS27743- 13	No QPL for AC Coils	Catalog Only	FCA-325-CY8	FCA-325-13
MS27743- 14	No QPL for AC Coils	Catalog Only	FCA-325-CX8	FCA-325-14
MS27743- 15	No QPL for AC Coils	Catalog Only	FCA-325-AV8	FCA-325-15
MS27743- 16	M83536/33-002L	FCA-325-3302L	FCA-325-CY4	FCA-325-16
MS27743- 17	M83536/33-005L	FCA-325-3305L	FCA-325-CX4	FCA-325-17
MS27743- 18	M83536/33-003L	FCA-325-3303L	FCA-325-AY4	FCA-325-18



Tyco Electronics Mid-Range Military/Aerospace Relays

CROSS REFERENCE GUIDE

**Superceded Mil-Spec Part Number to Current Mil-Spec Part Number to
 Tyco Electronics Part Number to Previous S-D Part Number (continued)
 Arranged Alphanumerically by Superceded Mil-Spec Part Number**

Superceded Mil-Spec Part Number	Current Mil-Spec Part Number	Tyco Electronics QPL Part Number	Catalog Equivalent (not QPL) Part Number	Superceded S-D Part Number
MS27743- 19	No QPL for AC Coils	Catalog Only	FCA-325-CY9	FCA-325-19
MS27743- 20	No QPL for AC Coils	Catalog Only	FCA-325-CX9	FCA-325-20
MS27743- 21	No QPL for AC Coils	Catalog Only	FCA-325-AV9	FCA-325-21
MS27743- 22	M83536/33-002L	FCA-325-3302L	FCA-325-CY4	FCA-325-22
MS27743- 23	M83536/33-005L	FCA-325-3305L	FCA-325-CX4	FCA-325-23
MS27743- 24	M83536/33-003L	FCA-325-3303L	FCA-325-AY4	FCA-325-24
MS27743- 25	No QPL for AC Coils	Catalog Only	FCA-325-CY9	FCA-325-25
MS27743- 26	No QPL for AC Coils	Catalog Only	FCA-325-CX9	FCA-325-26
MS27743- 27	No QPL for AC Coils	Catalog Only	FCA-325-AV9	FCA-325-27
MS27743- 28	M83536/32-001L	FCA-325-3201L	FCA-325-BY3	FCA-325-28
MS27743- 29	M83536/32-004L	FCA-325-3204L	FCA-325-BX3	FCA-325-29
MS27743- 30	M83536/32-001L	FCA-325-3201L	FCA-325-BY3	FCA-325-30
MS27743- 31	M83536/32-004L	FCA-325-3204L	FCA-325-BX3	FCA-325-31
MS27743- 32	M83536/33-001L	FCA-325-3301L	FCA-325-BY4	FCA-325-32
MS27743- 33	M83536/33-004L	FCA-325-3304L	FCA-325-BX4	FCA-325-33
MS27743- 34	M83536/33-001L	FCA-325-3301L	FCA-325-BY4	FCA-325-34
MS27743- 35	M83536/33-004L	FCA-325-3304L	FCA-325-BX4	FCA-325-35



Tyco Electronics Mid-Range Military/Aerospace Relays

SELECTION AND APPLICATION

This selection and application guide is suggested practices from ARP (Aerospace Recommended Practice) 4005 Concerning proper performance of relays

CAUTION; The use of any coil voltage less than the rated coil voltage may compromise the operation of the relay. Choosing the proper relay depends primarily on matching the relay to the load, power supply, and environment. Selection should be limited to items that meet the following requirements:

A. Contacts must be rated for the load. Current rating, type of load (resistive, lamp, motor, inductive, and so forth), impedance range, voltage rating, DC or AC, frequency, single phase or polyphase, polyphase load balance, and type of switching or transfer should all be considered. Each of the following switching and transfer functions places a different requirement on each of the relay contacts and must be considered when selecting a relay with the proper contact rating: **(1)** On-off switching - DC, single phase or polyphase. **(2)** motor reversing (AC or DC). **(3)** transferring load between phases of same source. **(4)** Transferring load between unsynchronized AC sources.

B. Power supply characteristics must be taken into account. Voltage regulation, variations in frequency, ripples and spikes, as well as steady state conditions, should be included. If more than one power supply is involved, not only must each be suitable but interaction between them also should be investigated.

C. Coil (or coils) should be rated so as to have proper operation under all anticipated conditions.

D. Consideration of environmental conditions anticipated throughout the service of life, as well as those expected during storage and transportation before installing the relays in equipment, is mandatory. Electrical parameters, environmental factors, mechanical stresses, and compatibility are among the categories for which the relay must be reviewed.

E. The circuit in which the relay is used, the interlocking feature employed, the wiring harness, and the associated components should all be reviewed for assuring mutual suitability.

F. Relays should be hard wired whenever possible, to avoid the need for additional contact points associated with the relay plug-in socket arrangement. (Plug-in types should be considered for quick turnaround times)

G. To permit "safe" isolation of relay circuit in the OFF condition, and better eliminate an electrical shock hazard, an electromechanical switching device should be placed between the positive terminal of the power source and the relay coil.

H. Proper Transistor control of the relay coil requires a stable reference voltage. This can be done by connecting the plus side of the coil to the positive side of the power source, the minus side of the relay coil to the collector of an NPN transistor, the emitter of the transistor to the grounded side of the power source, and the transistor base to the control voltage. For example, see MIL-R-28776/1.

I. Any switching device controlling the relay coil circuit must be capable of withstanding, without damage, the sum of the maximum coil circuit voltage and the peak value of transient voltage that results when the coil circuit is opened; for example, a switch controlling a relay coil that is supplied with a 28 V DC line and subjected to a transient voltage suppressed to 42 V must be capable of withstanding 28 V + 42 V or a 70 V surge without damage.

J. In selecting solid state electronic switching devices to control relay coil circuits, care must be used in selecting a solid state device with a leakage current (in the "off state") that is sufficiently low to permit the relay to drop out.

K. Control of the relay coil circuit by other than step-function switching may invalidate published relay performance properties such as pickup and dropout voltages, pickup, dropout, and bounce times.

SR·SS

SR

**FOUR POLE HALF SIZE
HIGH-PERFORMANCE RELAY**

QUALIFIED TO MIL-R-39016/40

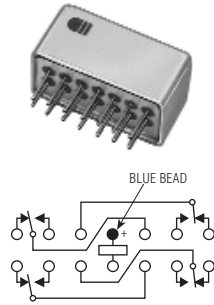

TERMINAL VIEW

FEATURES

- Hermetically sealed
- Up to 2 amps switching
- High shock & vibration ratings
- Optional terminals & mounting styles
- 4 form C Hi-density design

SS

**SIX POLE HALF SIZE
HIGH-PERFORMANCE RELAY**

DESIGNED TO MIL-R-39016

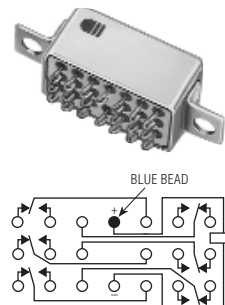

TERMINAL VIEW

FEATURES

- Hermetically sealed
- Up to 2 amps switching
- High shock & vibration ratings
- Optional terminals & mounting styles
- 6 form C Hi-density design

ELECTRICAL CHARACTERISTICS

CONTACT ARRANGEMENT

SR: 4 Form C (4PDT)
SS: 6 Form C (6PDT)

CONTACT MATERIAL

Stationary:
Gold plated hardened silver alloy
Moveable:
Gold plated hardened silver alloy

CONTACT RESISTANCE

Before Life: 50 milliohms max.
(measured at 10 mA @ 6 Vdc)

After Life: 100 milliohms max.
(measured @ 2 A @ 28 Vdc)

MECHANICAL LIFE EXPECTANCY

1 million operations min.

COIL VOLTAGE

6 to 26.5 Vdc

COIL POWER

2.6 watts max. @ 25°C

DUTY CYCLE

Continuous

PICK-UP VOLTAGE

Approximately 50% of
nominal coil voltage

PICK-UP SENSITIVITY

475 mW

CONTACT RATINGS

CONTACT LOAD	TYPE	OPERATIONS MIN.
2 A @ 28 Vdc	Resistive	100,000
0.3 A @ 115 Vac, 60 Hz & 400 Hz	Resistive	100,000
0.75 A @ 28 Vdc	Inductive (200mH)	100,000
0.1 A @ 28 Vdc	Intermediate	50,000
0.2 A @ 28 Vdc	Lamp	100,000
10 µA @ 50 mV	Low Level	1,000,000

SR • SS

OPERATING CHARACTERISTICS

TIMING

Operate Time:
5.0 ms max.

Release Time:
5.0 ms max.

CONTACT BOUNCE

5.0 ms max. (SR)
5.0 ms max. (SS)

DIELECTRIC WITHSTANDING VOLTAGE

Between Open Contacts:
350 Vrms 60 Hz

Between Adjacent Contacts:
500 Vrms 60 Hz

Between Contacts and Coil:
500 Vrms 60 Hz

INSULATION RESISTANCE

1,000 megohms min. @ 500 Vdc

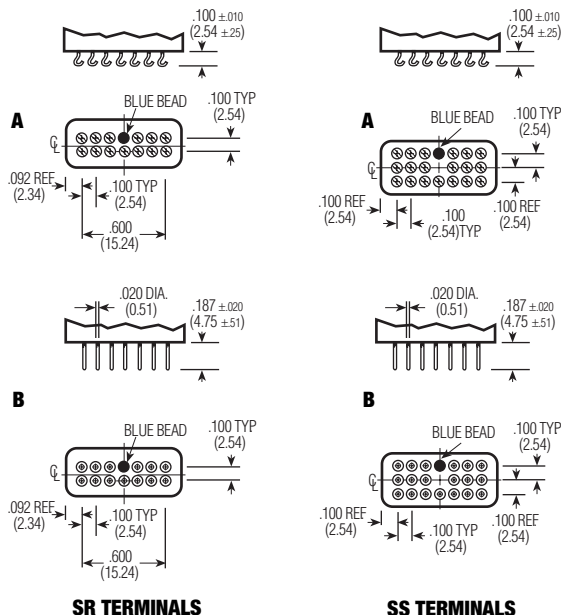

SR TERMINALS

SS TERMINALS

ENVIRONMENTAL CHARACTERISTICS

TEMPERATURE RANGE

-65°C to +125°C

WEIGHT

0.28 oz. (7.8 gms)

VIBRATION RESISTANCE

15 G's, 10 to 2,000 Hz

SHOCK RESISTANCE

100 G's, 6 ± 1 ms

QPL APPROVAL

MIL-R-39016/40 (SR)

QPL EQUIVALENT

MIL-R-39016 (SS)

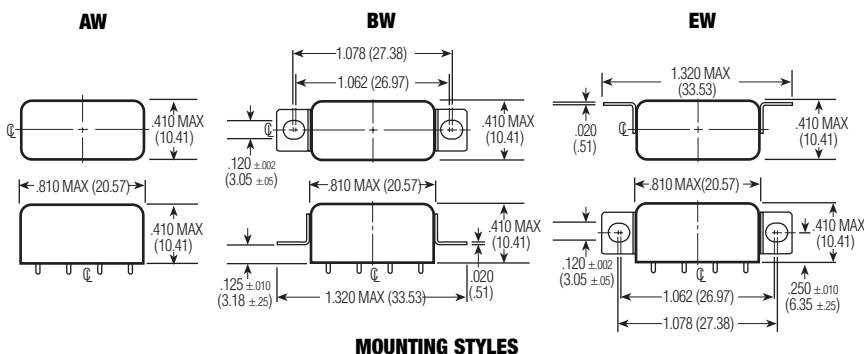

MOUNTING STYLES

STANDARD COIL DATA

NOM. COIL VOLTAGE (Vdc)	COIL RESISTANCE IN OHMS ±10% @ 25°C	PICKUP VOLTAGE Vdc (MAX.) @ 25°C	PICKUP VOLTAGE Vdc (MAX.) @ 125°C	DROPOUT VOLTAGE Vdc (MIN.) @ 25°C	DROPOUT VOLTAGE Vdc (MIN.) @ -65°C	NOM. COIL POWER (W) @ 25°C	MAX. COIL VOLTAGE	COIL DESIG.
5.0	20	2.75	3.8	0.35	0.23	1.25	6.0	5
6.0	25	3.5	4.5	0.45	0.3	1.44	8.0	6
12.0	100	6.5	9.0	0.9	0.6	1.44	15.0	12
26.5	390	14.0	18.0	1.8	1.2	1.8	32.0	24

SPECIFYING A PART NUMBER EXAMPLE:

TYPE	MOUNTINGS	CONTACTS	COILS	TERMINALS
SR	BW-	4C-	24	B
SS	BW-	6C-	24	B



SMGS · SMGSD · SMGSDD

SMGS

**SENSITIVE .100 GRID SURFACE MOUNT
HIGH-PERFORMANCE RELAY**

**DESIGNED TO
MIL-R-39016/41**

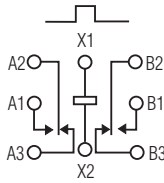

TERMINAL VIEW

FEATURES

- Hermetically sealed
- High shock & vibration ratings
- Surface mount leads
- Excellent RF switching

SMGSD

**SENSITIVE .100 GRID DIODE
SUPPRESSED SURFACE MOUNT HIGH-PER-
FORMANCE RELAY**

**DESIGNED TO
MIL-R-39016/42**

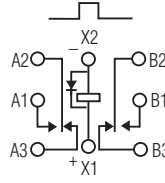

TERMINAL VIEW

FEATURES

- Suppression diode
- Hermetically sealed
- High shock & vibration ratings
- Surface mount leads
- Excellent RF switching

SMGSDD

**SENSITIVE .100 GRID DIODE
SUPPRESSED/PROTECTED SURFACE MOUNT
HIGH-PERFORMANCE RELAY**

**DESIGNED TO
MIL-R-39016/43**

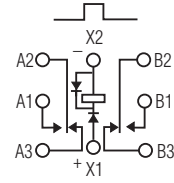

TERMINAL VIEW

FEATURES

- Suppression & protection diodes
- Hermetically sealed
- High shock & vibration ratings
- Surface mount leads
- Excellent RF switching

ELECTRICAL CHARACTERISTICS

CONTACT ARRANGEMENT
2 Form C (DPDT)

CONTACT MATERIAL
Stationary:
Gold/platinum/palladium/silver
(gold plated)
Moveable:
Gold/platinum/palladium/silver
(gold plated)

CONTACT RESISTANCE
Before Life: 100 milliohms max.
(measured @ 10 mA @ 6 Vdc)
After Life: 200 milliohms max.
(measured @ 1 A @ 28 Vdc)

MECHANICAL LIFE EXPECTANCY
1 million operations

COIL VOLTAGE
5 to 26.5 Vdc

COIL POWER
565 mW max. @ 25°C

DUTY CYCLE
Continuous

PICK-UP VOLTAGE
Approximately 50% of
nominal coil voltage

PICK-UP SENSITIVITY
130 mW max. @ 25°C

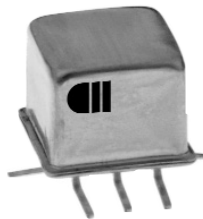

CONTACT RATINGS

CONTACT LOAD	TYPE	OPERATIONS MIN.
1.0 A @ 28 Vdc	Resistive	100,000
250 mA @ 115 Vac, 60 Hz & 400 Hz	Resistive (case not grounded)	100,000
100 mA @ 115 Vac, 60 Hz & 400 Hz	Resistive	100,000
0.2 A @ 28 Vdc	Inductive (0.32 Henry)	100,000
0.1 A @ 28 Vdc	Lamp	100,000
30 µA @ 50 mVdc	Low Level	1,000,000
0.1 A @ 28 Vdc	Intermediate Current	50,000

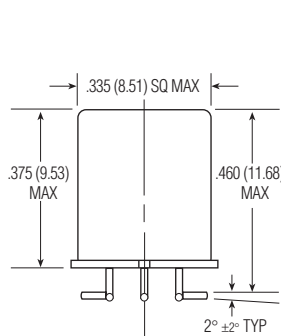

ENCLOSURE

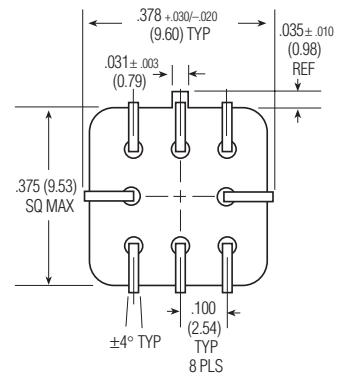

HEADER

.100 GRID SURFACE MOUNT HIGH-PERFORMANCE



OPERATING CHARACTERISTICS

TIMING

Operate Time:
4.0 ms max.

Release Time:
SMGS: 2.0 ms max.
SMGSD/SMGSD: 7.5 ms max.
(suppression diode, protection/sup-
pression diodes)

CONTACT BOUNCE

1.5 ms max.

DIELECTRIC WITHSTANDING VOLTAGE

Between Open Contacts:
500 Vrms 60 Hz

Between Adjacent Contacts:
500 Vrms 60 Hz

Between Contacts & Coil:
500 Vrms 60 Hz

INSULATION RESISTANCE

10,000 megohms min. @ 500 Vdc
1,000 megohms @ 500 Vdc
(coil to case @ +125°C)

ENVIRONMENTAL CHARACTERISTICS

TEMPERATURE RANGE

-65°C to +125°C

WEIGHT

0.09 oz. (2.55 gms)

VIBRATION RESISTANCE

30 G's, 10 to 3,000 Hz

SHOCK RESISTANCE

75 G's, 6 ± 1 ms max.

SEMICONDUCTOR CHARACTERISTICS

DIODE

100 Vdc peak inverse voltage (PIV)
1.0 Vdc max. transient voltage

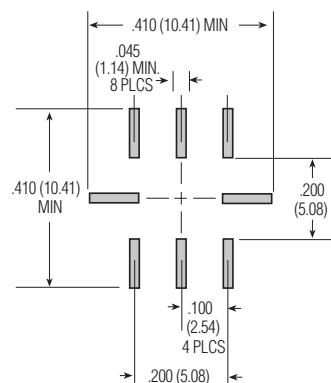

RECOMMENDED SOLDER PAD LAYOUT

COIL DATA

NOM. COIL VOLTAGE (Vdc)	COIL RESISTANCE IN OHMS ±10% @ 25°C (Note)	COIL CIRCUIT CURRENT mA (MAX.) (Note)	COIL CIRCUIT CURRENT mA (MIN.) (Note)	PICKUP VOLTAGE Vdc (MAX.) @ 25°C	PICKUP VOLTAGE Vdc (MAX.) @ 125°C	DROP-OUT VOLTAGE Vdc (MIN.) @ 25°C	DROP-OUT VOLTAGE Vdc (MIN.) @ -65°C	NOM. COIL POWER (mW) @ 25°C	MAX. COIL VOLTAGE	COIL DESIG.
SMGS/SMGSD										
5.0	100	n/a	n/a	2.6	3.5	0.23	0.12	250	7.5	5
6.0	200	n/a	n/a	3.4	4.5	0.28	0.18	180	10.0	6
9.0	400	n/a	n/a	4.85	6.8	0.55	0.35	203	15.0	9
12.0	800	n/a	n/a	7.0	9.0	0.64	0.41	180	20.0	12
18.0	1,600	n/a	n/a	9.8	13.5	0.92	0.59	203	30.0	18
26.5	3,200	n/a	n/a	14.0	18.0	1.4	0.89	219	40.0	26
36.0	6,500	n/a	n/a	20.0	27.0	1.8	1.25	199	57.0	36
48.0	11,000	n/a	n/a	25.8	36.0	2.4	1.60	209	75.0	48
SMGSD										
5.0	64	78.1	56.8	2.9	3.7	0.8	0.7	391	7.5	5
6.0	125	48.9	36.3	4.0	4.8	0.9	0.8	288	10.0	6
9.0	400	23.6	18.1	6.1	8.0	1.1	0.9	203	15.0	9
12.0	800	16.0	12.5	7.8	11.0	1.3	1.0	180	20.0	12
18.0	1,600	12.2	9.6	11.3	14.5	1.5	1.1	203	30.0	18
26.5	3,200	9.0	7.2	15.2	19.0	1.7	1.3	219	40.0	26
36.0	6,500	6.1	4.9	21.7	27.2	2.3	1.7	199	57.0	36
48.0	11,000	4.8	3.9	27.8	34.8	2.8	2.0	209	75.0	48

Note: Coil resistance not directly measurable. Coil current should be within limits shown when tested at nominal voltage at 25°C for 5 seconds max.

SPECIFYING A PART NUMBER EXAMPLE:

TYPE
SMGS
COILS
-26

DC SOLID STATE RELAYS

TS SERIES

50 TO 250 mA

MEETS MIL-R-28750/5,6, & 7

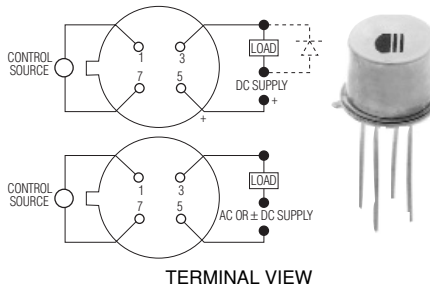

FEATURES

- Hermetically sealed TO-5 package
- Transformer coupled
- High speed switching
- TS5-1Y switches AC or DC

INPUT CHARACTERISTICS

INPUT VOLTAGE RANGE

4.0 – 7.0 Vdc

MAXIMUM TURN-ON VOLTAGE

5.0 Vdc

MINIMUM TURN-OFF VOLTAGE

1.0 Vdc

I/O DIELECTRIC

1000 Vac pk-pk

OUTPUT CHARACTERISTICS

MAX. OUTPUT CURRENT (CONTINUOUS, 25°C)

50 mAac or mAdc (TS5-1Y)
250 mAac (TS6-1Y)
100 mAac (TS7-1Y)

MAX. OUTPUT VOLTAGE

40 Vac or Vdc (TS5-1Y)
40 Vdc (TS6-1Y)
250 Vdc (TS7-1Y)

MAX. ON-RESISTANCE

5 ohms (TS5-1Y)

TURN-ON TIME

10 μsec.

TURN-OFF TIME

15 μsec.

ENVIRONMENTAL CHARACTERISTICS

SHOCK

1500 G's, 0.5 ms.

VIBRATION

100 G's, 10 to 2000 Hz

OPERATING AMBIENT TEMPERATURE

-55 to +125°C



DC SOLID STATE RELAYS

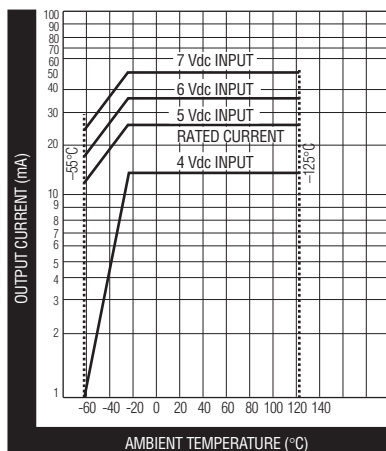

TS5-1Y

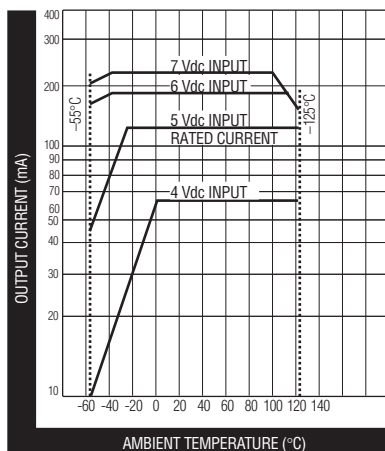

TS6-1Y

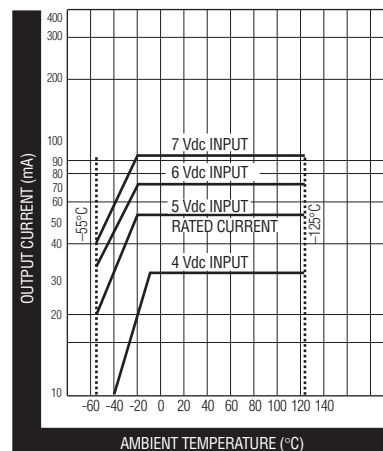

TS7-1Y

OUTPUT CURRENT VS. INPUT CONTROL VOLTAGE AND AMBIENT TEMPERATURE

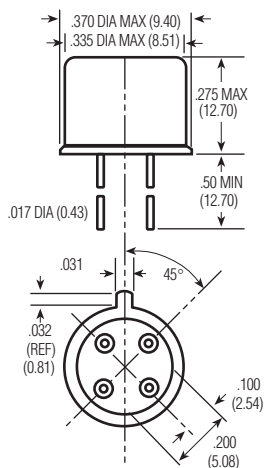

TS5/TS6/TS7

NOTES: 1) Reversing polarity of input (or output except for TS5-1) may cause permanent damage. 2) Input must be a step function. Rise or fall time, as applicable, not to exceed 100 μ sec. 3) Inductive loads must be diode suppressed. 4) For any control voltage, the maximum load current shown on graphs must not be exceeded. Attempting to draw currents in excess of those specified on graphs can cause permanent damage.



SMGA · SMGAD · SMGADD

SMGA

**STANDARD .100 GRID
SURFACE MOUNT HIGH-PERFORMANCE
RELAY**

**DESIGNED TO
MIL-R-39016/17**

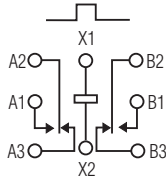

TERMINAL VIEW

FEATURES

- Hermetically sealed
- High shock & vibration ratings
- Surface mount leads
- Excellent RF switching

SMGAD

**STANDARD .100 GRID
DIODE SUPPRESSED SURFACE MOUNT HIGH-
PERFORMANCE RELAY**

**DESIGNED TO
MIL-R-39016/18**

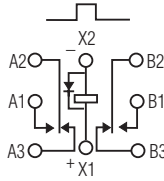

TERMINAL VIEW

FEATURES

- Suppression diode
- Hermetically sealed
- High shock & vibration ratings
- Surface mount leads
- Excellent RF switching

SMGADD

**STANDARD .100 GRID DIODE
SUPPRESSED/PROTECTED SURFACE MOUNT
HIGH-PERFORMANCE RELAY**

**DESIGNED TO
MIL-R-39016/19**

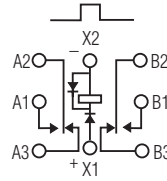

TERMINAL VIEW

FEATURES

- Suppression & protection diodes
- Hermetically sealed
- High shock & vibration ratings
- Surface mount leads
- Excellent RF switching

ELECTRICAL CHARACTERISTICS

CONTACT ARRANGEMENT
2 Form C (DPDT)

CONTACT MATERIAL
Stationary:
Gold/platinum/palladium/silver
(gold plated)

Moveable:
Gold/platinum/palladium/silver
(gold plated)

CONTACT RESISTANCE
Before Life: 100 milliohms max.
(measured @ 10 mA @ 6 Vdc)

After Life: 200 milliohms max.
(measured @ 1 A @ 28 Vdc)

MECHANICAL LIFE EXPECTANCY
1 million operations

COIL VOLTAGE
5 to 26.5 Vdc

COIL POWER
660 mW max. @ 25°C

DUTY CYCLE
Continuous

PICK-UP VOLTAGE
Approximately 50% of
nominal coil voltage

PICK-UP SENSITIVITY
130 mW max. @ 25°C

CONTACT RATINGS

CONTACT LOAD	TYPE	OPERATIONS MIN.
1.0 A @ 28 Vdc	Resistive	100,000
250 mA @ 115 Vac, 60 Hz & 400 Hz	Resistive (case not grounded)	100,000
100 mA @ 115 Vac, 60 Hz & 400 Hz	Resistive	100,000
0.2 A @ 28 Vdc	Inductive (0.32 Henry)	100,000
0.1 A @ 28 Vdc	Lamp	100,000
30 μA @ 50 mVdc	Low Level	1,000,000
0.1 A @ 28 Vdc	Intermediate Current	50,000

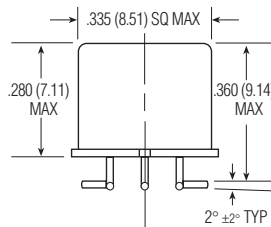
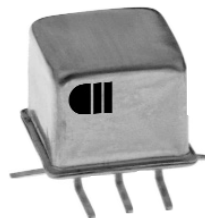

ENCLOSURE

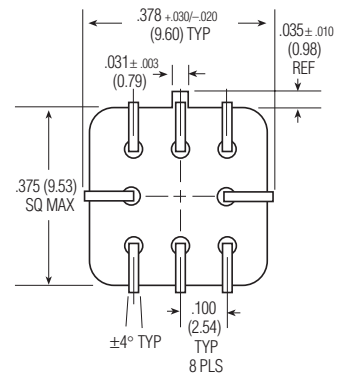

HEADER

.100 GRID SURFACE MOUNT HIGH-PERFORMANCE



OPERATING CHARACTERISTICS

TIMING

Operate Time:
2.0 ms max.

Release Time:
SMGA: 1.5 ms max.
SMGAD/SMGADD: 4.0 ms max.
(suppression diode, protection/suppression diodes)

CONTACT BOUNCE

1.5 ms max.

DIELECTRIC WITHSTANDING VOLTAGE

Between Open Contacts:
500 Vrms 60 Hz

Between Adjacent Contacts:
500 Vrms 60 Hz

Between Contacts & Coil:
500 Vrms 60 Hz

INSULATION RESISTANCE

10,000 megohms min. @ 500 Vdc
1,000 megohms @ 500 Vdc
(coil to case @ +125°C)

ENVIRONMENTAL CHARACTERISTICS

TEMPERATURE RANGE

-65°C to +125°C

WEIGHT

0.09 oz. (2.55 gms)

VIBRATION RESISTANCE

30 G's, 10 to 3,000 Hz

SHOCK RESISTANCE

75 G's, 6 ±1 ms max.

SEMICONDUCTOR CHARACTERISTICS

DIODE

100 Vdc peak inverse voltage (PIV)
1.0 Vdc max. transient voltage

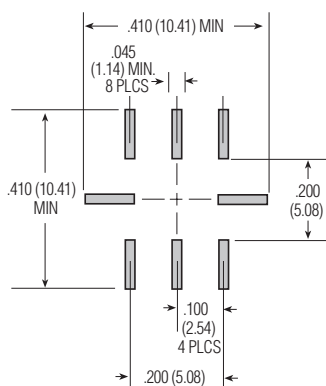

RECOMMENDED SOLDER PAD LAYOUT

COIL DATA

NOM. COIL VOLTAGE (Vdc)	COIL RESISTANCE IN OHMS ±10% @ 25°C (Note)	COIL CIRCUIT CURRENT mA (MAX.) (Note)	COIL CIRCUIT CURRENT mA (MIN.) (Note)	PICKUP VOLTAGE Vdc (MAX.) @ 25°C	PICKUP VOLTAGE Vdc (MAX.) @ 125°C	DROP-OUT VOLTAGE Vdc (MIN.) @ 25°C	DROP-OUT VOLTAGE Vdc (MIN.) @ -65°C	NOM. COIL POWER (mW) @ 25°C	MAX. COIL VOLTAGE	COIL DESIG.
SMGA/SMGAD										
5.0	50	n/a	n/a	2.7	3.5	0.22	0.14	500	5.8	5
6.0	98	n/a	n/a	3.5	4.5	0.28	0.18	367	8.0	6
9.0	220	n/a	n/a	5.3	6.8	0.54	0.35	368	12.0	9
12.0	390	n/a	n/a	7.0	9.0	0.63	0.41	369	16.0	12
18.0	880	n/a	n/a	10.5	13.5	0.91	0.59	368	24.0	18
26.5	1,560	n/a	n/a	14.2	18.0	1.37	0.89	450	32.0	26
SMGADD										
5.0	39	128.2	93.2	3.2	4.0	0.6	0.6	641	5.8	5
6.0	78	78.3	58.3	4.0	5.0	0.7	0.7	462	8.0	6
9.0	220	42.9	33.0	6.3	7.8	0.9	0.8	368	12.0	9
12.0	390	32.8	25.6	8.0	10.0	1.1	0.9	369	16.0	12
18.0	880	22.1	17.5	11.5	14.5	1.4	1.1	368	24.0	18
26.5	1,560	18.5	14.8	15.2	19.0	1.8	1.4	450	32.0	26

Note: Coil resistance not directly measurable. Coil current should be within limits shown when tested at nominal voltage at 25°C for 5 seconds max.

100 GRID SURFACE MOUNT HIGH-PERFORMANCE

SPECIFYING A PART NUMBER EXAMPLE:

TYPE
SMGA **COILS**
 -26

SHC · SHCD · SHCS · SHCSD

SHC · SHCS

**STANDARD • SENSITIVE
.100 GRID SURFACE MOUNT COM-
MERCIAL RELAY**

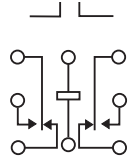

TERMINAL VIEW

FEATURES

- Hermetically sealed
- Excellent RF switching

SHCD · SHCSD

**STANDARD • SENSITIVE
.100 GRID SURFACE MOUNT
DIODE SUPPRESSED
COMMERCIAL RELAY**

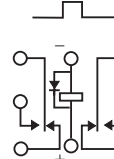

TERMINAL VIEW

FEATURES

- Suppression Diode
- Hermetically sealed
- Excellent RF switching

ELECTRICAL CHARACTERISTICS

CONTACT ARRANGEMENT

2 Form C (DPDT)

CONTACT MATERIAL

Stationary:
Gold/platinum/palladium/silver alloy
(gold plated)

Moveable:
Gold/platinum/palladium/silver alloy
(gold plated)

CONTACT RESISTANCE

Before Life:
100 milliohms max.
(measured @ 10 mA @ 6 Vdc)

After Life:
200 milliohms max.
(measured @ 1 A @ 28 Vdc)

MECHANICAL LIFE EXPECTANCY

1 million operations

ELECTRICAL CHARACTERISTICS

COIL VOLTAGE

5 to 26.5 Vdc (SHC/SHCD)
5 to 48 Vdc (SHCS/SHCSD)

COIL POWER

SHC/SHCD:
660 mW max. @ 25°C

SHCS/SHCSD:
565 mW max. @ 25°C

DUTY CYCLE

Continuous

PICK-UP VOLTAGE

Approximately 70% of
nominal coil voltage

PICK-UP SENSITIVITY

SHC/SHCD:
180 mW max. @ 25°C

SHCS/SHCSD:
90 mW max. @ 25°C

CONTACT RATINGS

CONTACT LOAD	TYPE	OPERATIONS MIN.
1.0 A @ 28 Vdc	Resistive	100,000
250 mA @ 115 Vac, 60 Hz & 400 Hz	Resistive (Case not grounded)	100,000
100 mA @ 115 Vac, 60 Hz & 400 Hz	Resistive	100,000
0.2 A @ 28 Vdc	Inductive (0.32 Henry)	100,000
0.1 A @ 28 Vdc	Lamp	100,000
30 µA @ 50 mVdc	Low Level	1,000,000

.100 GRID SURFACE MOUNT COMMERCIAL/INDUSTRIAL RELAYS



SHC · SHCD · SHCS · SHCSD

100 GRID SURFACE MOUNT COMMERCIAL/INDUSTRIAL RELAYS

OPERATING CHARACTERISTICS

TIMING

Operate Time:
SHC/SHCD: 4.0 ms max.
SHCS/SHCSD: 6.0 ms max.

Release Time:
SHC: 3.0 ms max.
SHCS: 3.0 ms max.
SHCD: 6.0 ms max.
(suppression diode)
SHCSD: 7.5 ms max.
(suppression diode)

DIELECTRIC WITHSTANDING VOLTAGE

Between Open Contacts:
350 Vrms 60 Hz

Between Adjacent Contacts:
350 Vrms 60 Hz

Between Contacts & Coil:
350 Vrms 60 Hz

INSULATION RESISTANCE

1,000 megohms @ 500 Vdc

ENVIRONMENTAL CHARACTERISTICS

TEMPERATURE RANGE

-55°C to + 85°C

WEIGHT

SHC/SHCD:
0.09 oz. (2.55 gms)

SHCS/SHCSD:
0.15 oz. (4.30 gms)

VIBRATION RESISTANCE

10 G's, 10 to 500 Hz

SHOCK RESISTANCE

30 G's, 6 ± 1 ms

SEMICONDUCTOR CHARACTERISTICS

DIODE

100 Vdc peak inverse voltage (PIV)
1.0 Vdc max. transient voltage

STANDARD COIL DATA

	NOM. COIL VOLTAGE (Vdc)	COIL RESISTANCE IN OHMS ±20% @ 25°C	PICKUP VOLTAGE Vdc (MAX.) @ 25°C	NOM. COIL POWER (mW) @ 25°C	MAX. COIL VOLTAGE	COIL DESIG.
SHC/SHCD	5.0	64	3.8	391	5.8	5
	6.0	98	4.9	367	8.0	6
	9.0	220	7.0	368	12.0	9
	12.0	400	9.0	360	16.0	12
	18.0	880	14.0	368	24.0	18
26.5	1,600	18.0	439	32.0	26	
SHCS/SHCSD	5.0	100	3.5	250	7.5	5
	6.0	200	4.5	180	10.0	6
	9.0	400	6.8	203	15.0	9
	12.0	800	9.0	180	20.0	12
	18.0	1,600	13.5	203	30.0	18
	26.5	3,200	18.0	219	40.0	26
	36.0	6,500	24.0	199	57.0	36
48.0	11,000	32.0	209	75.0	48	

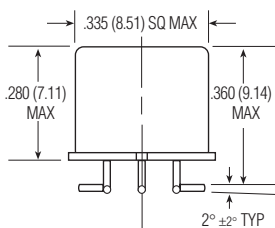

SHC/SHCD ENCLOSURE

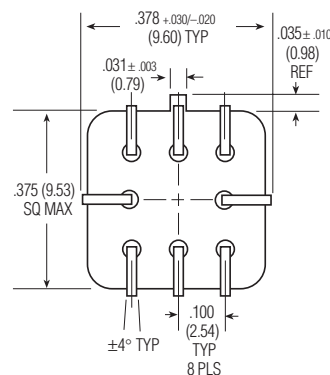

SHC/SHCD/SHCS/SHCSD HEADER

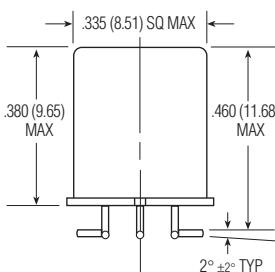

SHCS/SHCSD ENCLOSURE

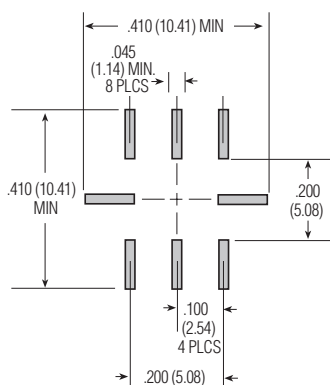

RECOMMENDED SOLDER PAD LAYOUT

SPECIFYING A PART NUMBER EXAMPLE:

TYPE SHC DIODES D GROUND PIN X COILS -26



AC solid state relay for loads up to 10A @ 250Vrms

Product Facts

- Approved to DSCC drawing 86031.
- Optically coupled all solid state relay.
- TTL compatible input.
- Zero voltage turn-on for low EMI.
- Custom power package with screw terminals.



The PS12 series solid state relay is designed for AC power switching up to 10 amps at 250Vrms. The circuit employs back-to-back SCRs with zero voltage turn-on for reliable switch-

ing of resistive or reactive loads. TTL compatible input circuitry is optically isolated to 1,500Vrms from the AC load circuit. The relay is offered in two versions: the PS12-1Y with "Y" level

screening per Mil-R-28750C, and the PS12-1W screened per Tyco Electronics specifications for CII relays, equivalent to former "W" level of Mil-R-28750.

CII Part Number	DSCC Part Number	Screening Level
PS12-1Y	86031-001	Y
PS12-1W	N/A	W

Circuit Diagram

Terminal View

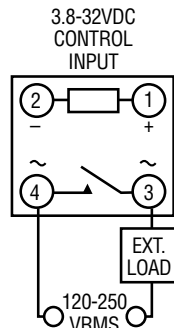

Outline Drawing

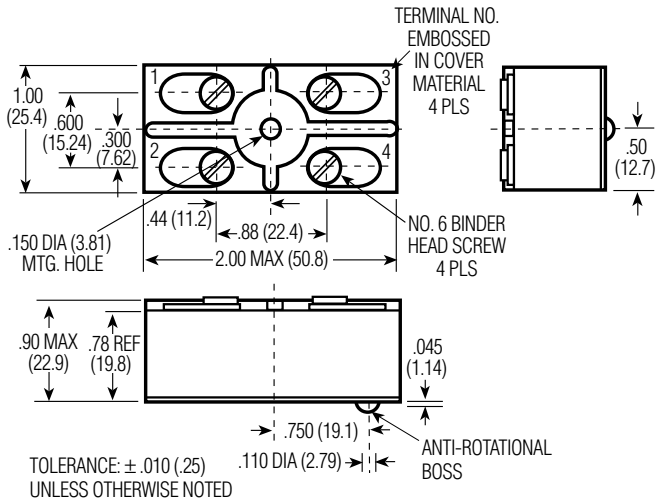



AC solid state relay for loads up to 10A @ 250Vrms (Continued)

Environmental Characteristics

Ambient Temperature Range:

Operating: -55°C to +95°C.
Storage: -55°C to +110°C.

Vibration Resistance:

30 G's, 78-2,000 Hz.

Shock Resistance:

100 G's, 6 ms pulse.

Constant Acceleration Resistance:

100 G's.

Mechanical Characteristics

Weight (max.):

3 oz. (85 grams)

Materials:

Case: Plastic, self-extinguishing, epoxy filled
Terminals: Brass, nickel-plated.
Base Plate: Aluminum

NOTE: Do not exceed 180 in-oz when tightening screws.

Electrical Specifications (-55°C to +95°C unless otherwise specified)

Input

Input supply voltage range (Vcc)	3.8 - 32 Vdc
Input current (max.) @ 5Vdc	16mAdc
Must turn-on voltage	3.8Vdc
Must turn-off voltage	1Vdc
Reverse voltage protection	-32Vdc

I/O

Dielectric strength (min.)	1,500V rms/60 Hz.
Insulation resistance (min.) @ 500Vdc	10 ⁸ ohms
Capacitance (max.)	15pF

Output

Output current rating (max.)	10A rms (Fig. 2, Note 1)
Surge current (max.)	100A pk (Fig. 1, Note 2)
Continuous load voltage (max.)	250V rms
Transient blocking voltage (max.)	460V pk
Frequency range	45 - 440 Hz.
Output voltage drop (max.) @ 25A load current	1.5V rms
Off-state leakage current (max.) @ 220V rms/400 Hz.	9mA rms
Turn-on time (max.)	1/2 cycle
Turn-off time (max.)	1 cycle
Off-state dv/dt (min.), with snubber	200V/μs (Note 3)
Zero voltage turn-on window (max.)	±15V pk
Output chip junction temperature (max.)	125°C (Note 1)
Thermal resistance (max.), junction to ambient	11.5°C/W
Thermal resistance (max.), junction to case	2.0°C/W
Fusing I ² T, 1 ms (max.)	150A ² s
Load power factor (min.)	0.2
Power dissipation (max.)	1.5W/A

Notes

1. Operation at elevated load currents up to 10 amps is dependent on the use of suitable heatsink to limit junction temperature.
2. Heating of output chips during and after a surge may cause loss of output blocking capability until junction temperature falls below maximum rating.
3. Internal snubber network is provided across output chips.

Figure 1 - Peak Surge Current vs. Surge Current Duration

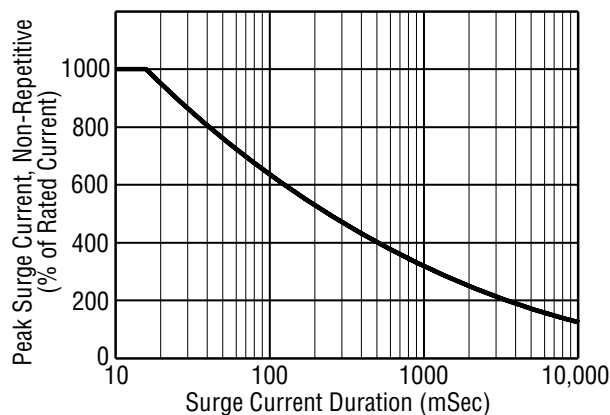
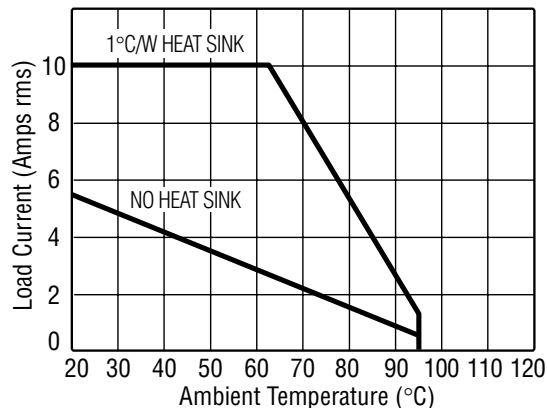

Figure 2 - Load Current vs. Temperature





Microwave Switching, Hermetically Sealed, DPDT

Product Facts

- Excellent signal isolation, stable insertion loss and low VSWR.
- Provide repeatable RF performance at frequencies up to the 3 GHz. level (MW3/MW3HP), 4 GHz. level (MW4/MW4HP) & 6 GHz. level (MW6/MW6HP).
- Standard versions for applications ranging from wireless communications to precision high-speed test equipment.
- High performance (HP) versions for use under more demanding environmental conditions.
- Standard or sensitive (S) coils are offered in a range of DC input voltages.
- 2 Form C (DPDT) contacts rated low-level to 1 amp.
- Extended mechanical life expectancy of 10 million operations.
- Robust, hermetically sealed enclosure.

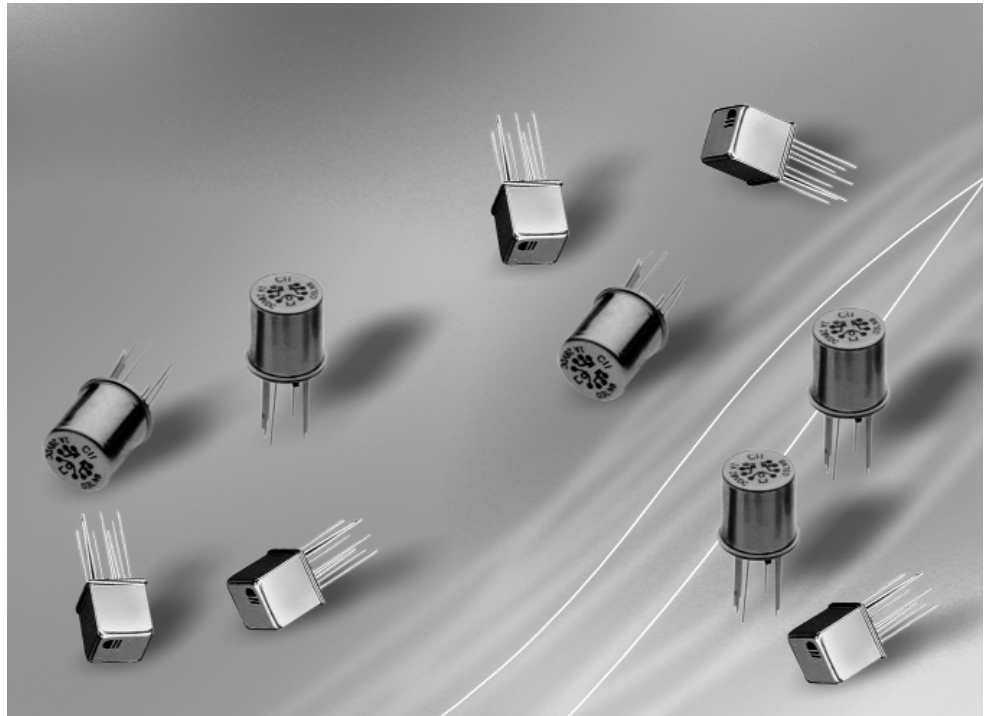

These CII relays provide microwave frequency switching in a hermetically sealed, subminiature package.

Both standard and high performance models are offered in 3 GHz., 4 GHz. and 6 GHz. types.

Standard models (MW3, MW4 and MW6) perform in temperature ranges from -55°C to +85°C and withstand 10G vibration and 30G shock.

High performance models (MW3HP, MW4HP and MW6HP) offer extended temperature ratings of -65°C to +125°C while providing 30G's vibration and 100G's shock (75G's for MW3) environmental ratings.

All are available with either standard or sensitive DC coils. Nominal coil power is 367-500mW (model dependent) for standard coils and 169-250mW for sensitive coils.

Signal isolation is 18dB at 6 GHz. (MW6/MW6HP), 18dB at 4 GHz. (MW4/MW4HP), and 22dB at 3 GHz. (MW3/MW3HP).

Insertion loss is 0.38dB for MW6/MW6HP, 0.27dB for MW4/MW4HP, and 0.36dB for MW3/MW3HP.

VSWR is a low 1.30:1 @ 6GHz. for MW6/MW6HP, 1.36:1 @ 4GHz. for MW4/MW4HP, and 1.24:1 @ 3GHz. for MW3/MW3HP.



**MW3 & MW3HP Models
3 GHz. Switching**

Electrical Characteristics

Contact Arrangement:

2 Form C (DPDT)

Contact Resistance:

Before life: 100 milliohms, max (measured @ 10mA @ 6VDC.)
After life: 200 milliohms, max (measured @ 1A @ 28VDC.)

Mechanical Life Expectancy:

10 million operations

Coil Voltages:

5, 12, 18 & 26.5VDC (MW3)
5, 6, 9, 12, 18 & 26.5VDC (MW3HP)

Coil Power (mw max @25°C):

MW3	MW3S	MW3HP	MW3HPS
675	565	673	563

Duty Cycle:

Continuous

Pick-up Voltage:

MW3: Approx 70% of nominal.
MW3HP: Approx 50% of nominal.

Pick-up Sensitivity (mw max @25°C):

MW3	MW3S	MW3HP	MW3HPS
180	90	146	68

Operating Characteristics

Timing:

Operate Time (ms max.)
MW3 MW3S MW3HP MW3HPS
4.0 6.0 2.0 4.0

Release Time (ms max.)
MW3 MW3S MW3HP MW3HPS
3.0 3.0 1.5 2.0

Bounce Time (ms max.)
MW3 MW3S MW3HP MW3HPS
- - 1.5 1.5

Dielectric Withstanding Voltage:

Between Open Contacts,
Between Adjacent Contacts and
Between Contacts and Coil:
MW3 types: 350Vrms, 60 Hz.
MW3HP types: 500Vrms, 60 Hz.

Insulation Resistance:

1,000 megohms @ 500VDC.

Environmental Characteristics

Temperature Range:

MW3 types: -55°C to +85°C.
MW3HP types: -65°C to +125°C.

Weight:

MW3, MW3HP: 0.09 oz. (2.55 g)
MW3S, MW3HPS: 0.12 oz. (3.40 g).

Vibration Resistance:

MW3 types: 10 G's, 10-500 Hz.
MW3HP types: 30 G's, 10-3,000 Hz

Shock Resistance:

MW3 types: 30 G's, 6 ± 1 ms.
MW3HP types: 75 G's, 6 ± 1 ms.

Contact Ratings

Contact Load	Type	Operations (min.)
1.0A @ 28VDC	Resistive	100,000
200mA @ 28VDC (300mH)*	Inductive	100,000
30µA @ 50mVDC	Low Level	10,000,000

* The inductive rating is only applicable to high performance models (MW3HP and MW3HPS).

Coil Data

MW3 Models

Nominal Coil Voltage (VDC)	Coil Resistance In Ohms ±20% @ 25°C	Pickup Voltage VDC (Max.) @ 25°C	Nominal Coil Power (mw) @ 25°C	Maximum Coil Voltage	Coil Designator
----------------------------	-------------------------------------	----------------------------------	--------------------------------	----------------------	-----------------

Standard Coil

5.0	50	3.6	500	5.8	5
12.0	390	8.4	369	16.0	12
18.0	880	13.0	368	24.0	18
26.5	1,560	17.0	450	32.0	26

Sensitive Coil

5.0	100	3.5	250	7.5	5
12.0	850	9.0	169	20.0	12
18.0	1,600	13.5	203	30.0	18
26.5	3,300	18.0	213	40.0	26

MW3HP (High Performance) Models

Nominal Coil Voltage (VDC)	Coil Res. in Ohms ±10% @ 25°C	Pickup V VDC (Max.) @25°C	Release V VDC (Max.) @25°C	Release V VDC (Min.) @25°C	Nominal Coil Power (mw) @25°C	Maximum Coil Voltage	Coil Designator
----------------------------	-------------------------------	---------------------------	----------------------------	----------------------------	-------------------------------	----------------------	-----------------

Standard Coil

5.0	50	2.7	1.4	0.22	500	5.8	5
6.0	98	3.5	2.0	0.28	367	8.0	6
9.0	220	5.3	3.0	0.54	368	12.0	9
12.0	390	7.0	4.0	0.63	369	16.0	12
18.0	880	10.5	6.0	0.91	368	24.0	18
26.5	1,560	14.2	8.0	1.37	450	32.0	26

Sensitive Coil

5.0	100	2.6	1.4	0.23	250	7.5	5
6.0	200	3.4	2.0	0.28	180	10.0	6
9.0	400	4.85	3.0	0.55	203	15.0	9
12.0	850	7.0	4.0	0.64	169	20.0	12
18.0	1,600	9.8	6.0	0.92	203	30.0	18
26.5	3,300	14.0	8.0	1.4	213	40.0	26



**MW3 & MW3HP Models
3 GHz. Switching**

Insertion Loss & VSWR: NO Contacts

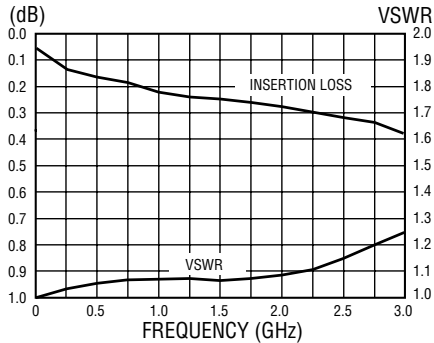

Insertion Loss & VSWR: NC Contacts

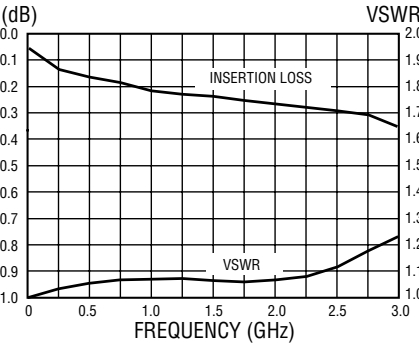

Isolation

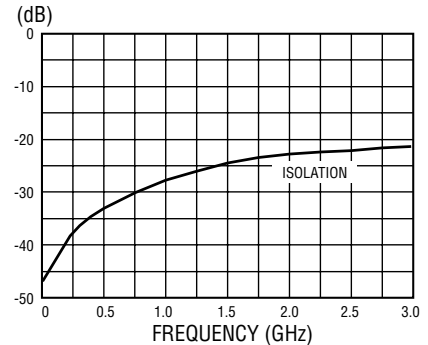

Test Conditions

Test Board: 0.031" double sided copper clad, PTFE based laminate.

Connections: Relay header is soldered to ground plane. Relay terminals are soldered to through holes. SMA connectors are soldered to circuit traces.

Temperature: Room ambient.

Signal Strength: 0 dBm.

Notes: 1. Unused terminals were terminated with 50 ohm impedance load. 2. All readings are typical.

Enclosures

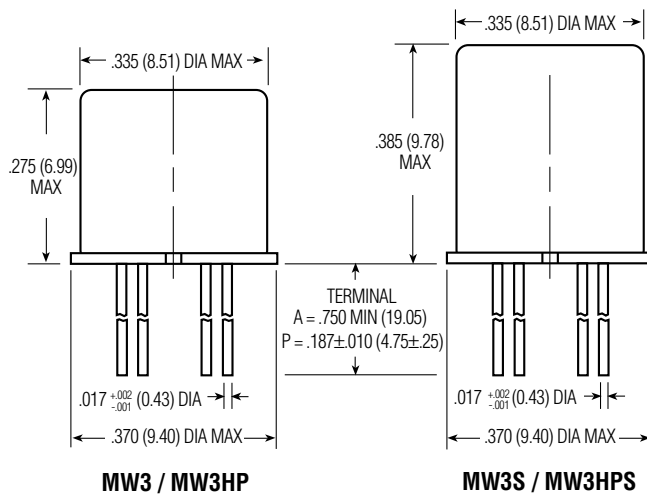

Header

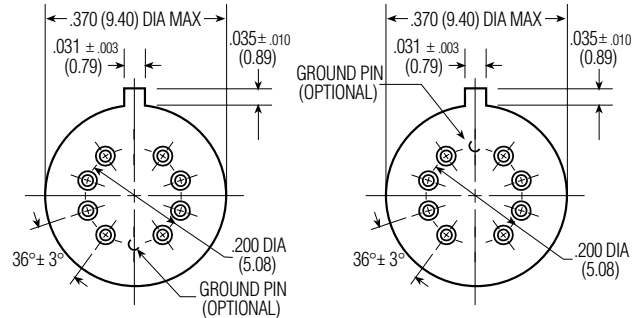

Ground Pin Position "G"

Ground Pin Position "E"

For other ground pin configurations consult factory.

Header and Terminal Finish:
Nickel plated on MW3 & MW3S.
Tin-lead plated on MW3HP & MW3HPS.

Part Numbering System

Typical Part Number	MW3	S	-5	A	G
Series:	MW3 = 3 GHz. switching relay MW3HP = High performance 3 GHz. switching relay				
Coil Sensitivity:	Leave Blank = Standard Coil S = Sensitive Coil				
Coil Designator:	5 = 5VDC 6 = 6VDC† 9 = 9VDC† 12 = 12VDC 18 = 18VDC 26 = 26.5VDC † 6 and 9 volt coil only available on high performance models.				
Terminal Length:	A = 0.750 in (19.05 mm) P = 0.187 ± 0.010 in (4.75 ± 0.25 mm)				
Ground Pin Position (see header drawings above):	G = Opposite locating tab E = Near locating tab. Consult factory for other ground pin configurations.				

Wiring Diagram

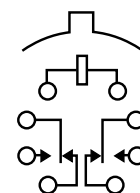

Terminal View

**MW4 & MW4HP Models
4 GHz. Switching**
Electrical Characteristics
Contact Arrangement:

2 Form C (DPDT)

Contact Resistance:

 Before life: 100 milliohms, max
(measured @ 10mA @ 6VDC.)
After life: 200 milliohms, max
(measured @ 1A @ 28VDC.)

Mechanical Life Expectancy:

10 million operations

Coil Voltages:

 5, 12, 18 & 26.5VDC (MW4)
5, 6, 9, 12, 18 & 26.5VDC (MW4HP)

Coil Power (mw max @25°C):

MW4	MW4S	MW4HP	MW4HPS
675	565	673	563

Duty Cycle:

Continuous

Pick-up Voltage:

 MW4: Approx 70% of nominal.
MW4HP: Approx 50% of nominal.

Pick-up Sensitivity (mw max @25°C):

MW4	MW4S	MW4HP	MW4HPS
180	90	123	68

Operating Characteristics
Timing:

Operate Time (ms max.)

MW4	MW4S	MW4HP	MW4HPS
4.0	6.0	2.0	4.0

Release Time (ms max.)

MW4	MW4S	MW4HP	MW4HPS
3.0	3.0	1.5	2.0

Bounce Time (ms max.)

MW4	MW4S	MW4HP	MW4HPS
-	-	1.5	1.5

Dielectric Withstanding Voltage:

 Between Open Contacts,
Between Adjacent Contacts and
Between Contacts and Coil:
MW4 types: 350Vrms, 60 Hz.
MW4HP types: 500Vrms, 60 Hz.

Insulation Resistance:

1,000 megohms @ 500VDC.

Environmental Characteristics
Temperature Range:

 MW4 types: -55°C to +85°C.
MW4HP types: -65°C to +125°C.

Weight:

 MW4, MW4HP: 0.09 oz. (2.55 g)
MW4S, MW4HPS: 0.12 oz. (3.40 g).

Vibration Resistance:

 MW4 types: 10 G's, 10-500 Hz.
MW4HP types: 30 G's, 10-3,000 Hz

Shock Resistance:

 MW4 types: 30 G's, 6 ± 1 ms.
MW4HP types: 100 G's, 6 ± 1 ms.

Contact Ratings

Contact Load	Type	Operations (min.)
1.0A @ 28VDC	Resistive	100,000
200mA @ 28VDC (300mH)*	Inductive	100,000
30µA @ 50mVDC	Low Level	10,000,000

* The inductive rating is only applicable to high performance models (MW4HP and MW4HPS).

Coil Data
MW4 Models

Nominal Coil Voltage (VDC)	Coil Resistance In Ohms ±20% @ 25°C	Pickup Voltage VDC (Max.) @ 25°C	Nominal Coil Power (mw) @ 25°C	Maximum Coil Voltage	Coil Designator
----------------------------	-------------------------------------	----------------------------------	--------------------------------	----------------------	-----------------

Standard Coil

5.0	50	3.6	500	5.8	5
12.0	390	8.4	369	16.0	12
18.0	880	13.0	368	24.0	18
26.5	1,560	17.0	450	32.0	26

Sensitive Coil

5.0	100	3.5	250	7.5	5
12.0	850	9.0	169	20.0	12
18.0	1,600	13.5	203	30.0	18
26.5	3,300	18.0	213	40.0	26

MW4HP (High Performance) Models

Nominal Coil Voltage (VDC)	Coil Res. in Ohms ±10% @ 25°C	Pickup V VDC (Max.) @25°C	Release V VDC (Max.) @25°C	Release V VDC (Min.) @25°C	Nominal Coil Power (mw) @25°C	Maximum Coil Voltage	Coil Designator
----------------------------	-------------------------------	---------------------------	----------------------------	----------------------------	-------------------------------	----------------------	-----------------

Standard Coil

5.0	50	2.7	1.4	0.22	500	5.8	5
6.0	98	3.5	2.0	0.28	367	8.0	6
9.0	220	5.3	3.0	0.54	368	12.0	9
12.0	390	7.0	4.0	0.63	369	16.0	12
18.0	880	10.5	6.0	0.91	368	24.0	18
26.5	1,560	14.2	8.0	1.37	450	32.0	26

Sensitive Coil

5.0	100	2.6	1.4	0.23	250	7.5	5
6.0	200	3.4	2.0	0.28	180	10.0	6
9.0	400	4.85	3.0	0.55	203	15.0	9
12.0	850	7.0	4.0	0.64	169	20.0	12
18.0	1,600	9.8	6.0	0.92	203	30.0	18
26.5	3,300	14.0	8.0	1.4	213	40.0	26

**MW4 & MW4HP Models
4 GHz. Switching**

Insertion Loss & VSWR: NO Contacts

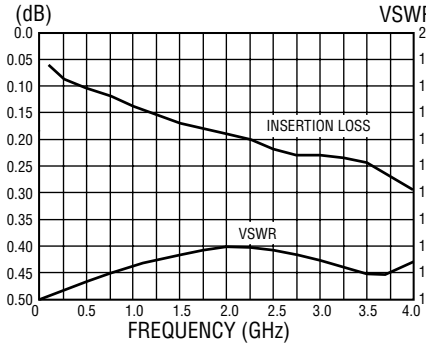

Insertion Loss & VSWR: NC Contacts

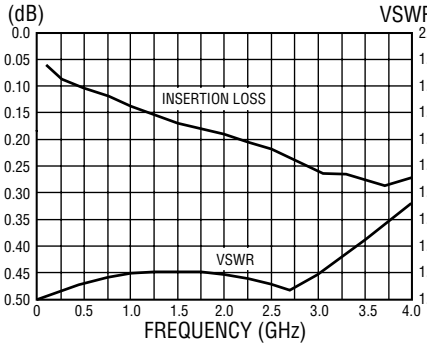

Isolation

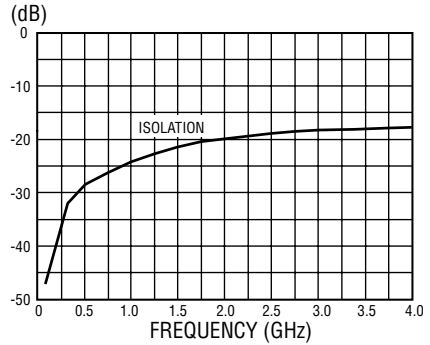

Test Conditions

Test Board: 0.031" double sided copper clad, PTFE based laminate.
Connections: Relay header is soldered to ground plane. Relay terminals are soldered to through holes. SMA connectors are soldered to circuit traces.
Temperature: Room ambient.
Signal Strength: 0 dBm.
Notes: 1. Unused terminals were terminated with 50 ohm impedance load. 2. All readings are typical.

Enclosures

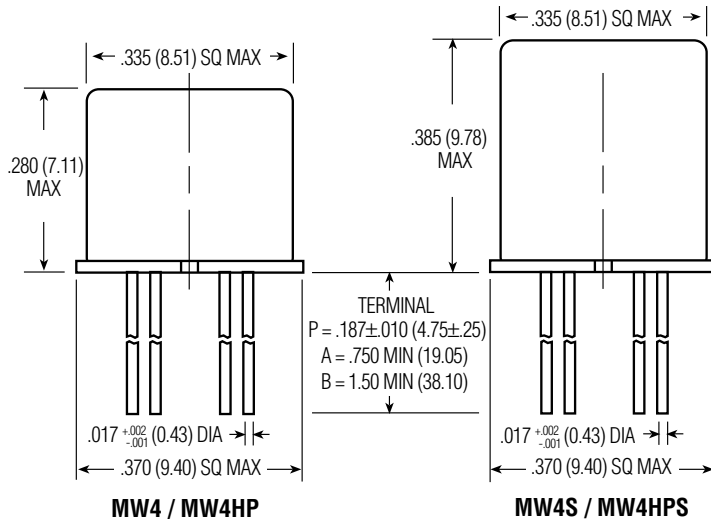

Header

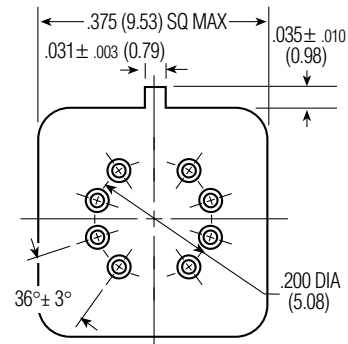

**Header and Terminal Finish:
Gold plated**

Part Numbering System

Typical Part Number MW4 S - 5 P

Series:
 MW4 = 4 GHz. switching relay
 MW4HP = High performance 4 GHz. switching relay

Coil Sensitivity:
 Leave Blank = Standard Coil S = Sensitive Coil

Coil Designator:
 5 = 5VDC 6 = 6VDC† 9 = 9VDC†
 12 = 12VDC 18 = 18VDC 26 = 26.5VDC
 † 6 and 9 volt coil only available on high performance models.

Terminal Length:
 A = 0.750 in (19.05 mm)
 B = 1.50 in (38.105 mm) – only available on high performance models
 P = 0.187 ± 0.010 in (4.75 ± 0.25 mm)

Wiring Diagram

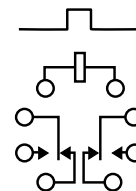

Terminal View

**MW6 & MW6HP Models
6 GHz. Switching**
Electrical Characteristics
Contact Arrangement:
2 Form C (DPDT)

Contact Resistance:
Before life: 100 milliohms, max
(measured @ 10mA @ 6VDC.)
After life: 200 milliohms, max
(measured @ 1A @ 28VDC.)

Mechanical Life Expectancy:
10 million operations

Coil Voltages:
5, 12, 18 & 26.5VDC (MW6)
5, 6, 9, 12, 18 & 26.5VDC (MW6HP)

Coil Power (mw max @25°C):

MW6	MW6S	MW6HP	MW6HPS
675	565	673	563

Duty Cycle:
Continuous

Pick-up Voltage:
MW6: Approx 70% of nominal.
MW6HP: Approx 50% of nominal.

Pick-up Sensitivity (mw max @25°C):

MW6	MW6S	MW6HP	MW6HPS
180	90	123	68

Operating Characteristics
Timing:
Operate Time (ms max.)

MW6	MW6S	MW6HP	MW6HPS
4.0	6.0	2.0	4.0

Release Time (ms max.)

MW6	MW6S	MW6HP	MW6HPS
3.0	3.0	1.5	2.0

Bounce Time (ms max.)

MW6	MW6S	MW6HP	MW6HPS
-	-	1.5	1.5

Dielectric Withstanding Voltage:
Between Open Contacts,
Between Adjacent Contacts and
Between Contacts and Coil:
MW6 types: 350Vrms, 60 Hz.
MW6HP types: 500Vrms, 60 Hz.

Insulation Resistance:
1,000 megohms @ 500VDC.

Environmental Characteristics
Temperature Range:
MW6 types: -55°C to +85°C.
MW6HP types: -65°C to +125°C.

Weight:
MW6, MW6HP: 0.09 oz. (2.55 g)
MW6S, MW6HPS: 0.12 oz. (3.40 g).

Vibration Resistance:
MW6 types: 10 G's, 10-500 Hz.
MW6HP types: 30 G's, 10-3,000 Hz

Shock Resistance:
MW6 types: 30 G's, 6 ± 1 ms.
MW6HP types: 100 G's, 6 ± 1 ms.

Contact Ratings

Contact Load	Type	Operations (min.)
1.0A @ 28VDC	Resistive	100,000
200mA @ 28VDC (300mH)*	Inductive	100,000
30µA @ 50mVDC	Low Level	10,000,000

* The inductive rating is only applicable to high performance models (MW6HP and MW6HPS).

Coil Data
MW6 Models

Nominal Coil Voltage (VDC)	Coil Resistance In Ohms ±20% @ 25°C	Pickup Voltage VDC (Max.) @ 25°C	Nominal Coil Power (mw) @ 25°C	Maximum Coil Voltage	Coil Designator
Standard Coil					
5.0	50	3.6	500	5.8	5
12.0	390	8.4	369	16.0	12
18.0	880	13.0	368	24.0	18
26.5	1,560	17.0	450	32.0	26

Sensitive Coil

5.0	100	3.5	250	7.5	5
12.0	850	9.0	169	20.0	12
18.0	1,600	13.5	203	30.0	18
26.5	3,300	18.0	213	40.0	26

MW6HP (High Performance) Models

Nominal Coil Voltage (VDC)	Coil Res. in Ohms ±10% @ 25°C	Pickup V VDC (Max.) @25°C	Release V VDC (Max.) @25°C	Release V VDC (Min.) @25°C	Nominal Coil Power (mw) @25°C	Maximum Coil Voltage	Coil Designator
Standard Coil							
5.0	50	2.7	1.4	0.22	500	5.8	5
6.0	98	3.5	2.0	0.28	367	8.0	6
9.0	220	5.3	3.0	0.54	368	12.0	9
12.0	390	7.0	4.0	0.63	369	16.0	12
18.0	880	10.5	6.0	0.91	368	24.0	18
26.5	1,560	14.2	8.0	1.37	450	32.0	26

Sensitive Coil

5.0	100	2.6	1.4	0.23	250	7.5	5
6.0	200	3.4	2.0	0.28	180	10.0	6
9.0	400	4.85	3.0	0.55	203	15.0	9
12.0	850	7.0	4.0	0.64	169	20.0	12
18.0	1,600	9.8	6.0	0.92	203	30.0	18
26.5	3,300	14.0	8.0	1.4	213	40.0	26



MW6 & MW6HP Models 6 GHz. Switching

Insertion Loss & VSWR: NO Contacts

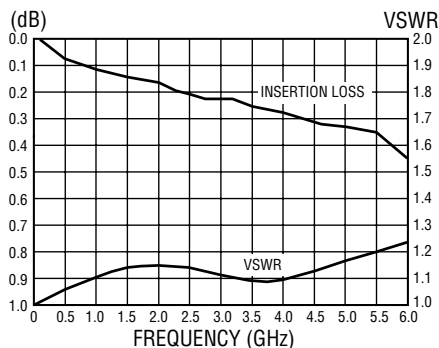

Insertion Loss & VSWR: NC Contacts

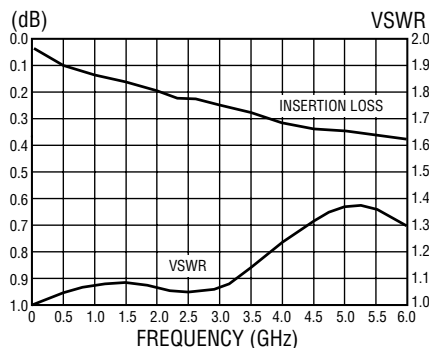

Isolation

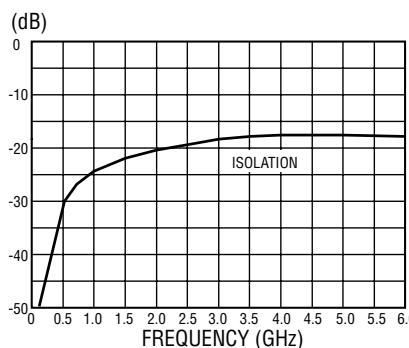

Test Conditions

Test Board: 0.031" double sided copper clad, PTFE based laminate.

Connections: Relay header is soldered to ground plane. Relay terminals are soldered to through holes. SMA connectors are soldered to circuit traces.

Temperature: Room ambient.

Signal Strength: 0 dBm.

Notes: 1. Unused terminals were terminated with 50 ohm impedance load. 2. All readings are typical.

Enclosures

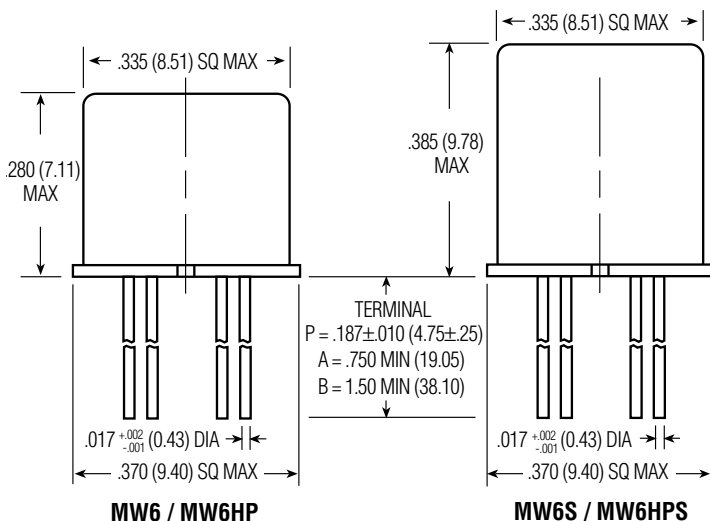

Header

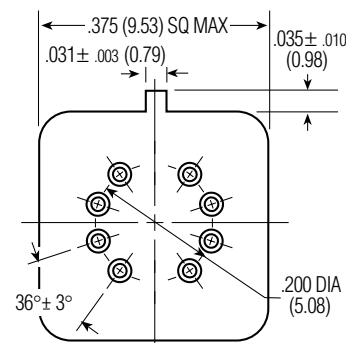

Header and Terminal Finish:
Gold plated

Part Numbering System

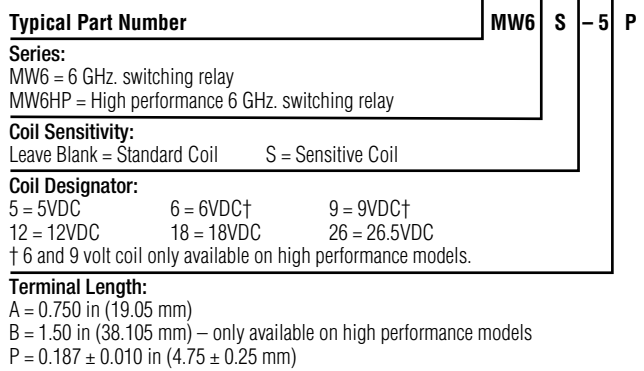

Wiring Diagram

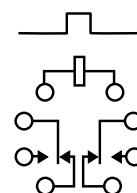

Terminal View

MS · MSD · MSDD · MST

T0-5 HIGH-PERFORMANCE RELAYS

MS

**SENSITIVE TO-5
HIGH-PERFORMANCE RELAY**

**QUALIFIED TO
MIL-R-39016/11**

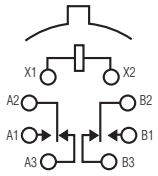

TERMINAL VIEW

FEATURES

- Hermetically sealed
- High shock & vibration ratings
- Spreader pads
- Excellent RF switching

MSD

**SENSITIVE TO-5
DIODE SUPPRESSED
HIGH-PERFORMANCE RELAY**

**QUALIFIED TO
MIL-R-39016/16**

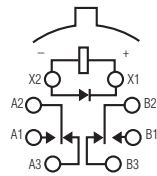

TERMINAL VIEW

FEATURES

- Suppression diode
- Hermetically sealed
- High shock & vibration ratings
- Spreader pads
- Excellent RF switching

MSDD

**SENSITIVE TO-5 DIODE
SUPPRESSED/PROTECTED
HIGH-PERFORMANCE RELAY**

**QUALIFIED TO
MIL-R-39016/21**

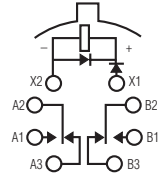

TERMINAL VIEW

FEATURES

- Suppression & protection diodes
- Hermetically sealed
- High shock & vibration ratings
- Spreader pads
- Excellent RF switching

MST

**SENSITIVE TO-5 DIODE
SUPPRESSED/TRANSISTOR DRIVEN
HIGH-PERFORMANCE
RELAY**

**QUALIFIED TO
MIL-R-28776/3**

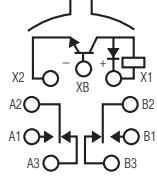

TERMINAL VIEW

FEATURES

- Transistor driver & suppression diode
- Hermetically sealed
- High shock & vibration ratings
- Spreader pads
- Excellent RF switching

ELECTRICAL CHARACTERISTICS

CONTACT ARRANGEMENT
2 Form C (DPDT)

CONTACT MATERIAL
Stationary:
Gold/platinum/palladium/silver alloy (gold plated)

Moveable:
Gold/platinum/palladium/silver alloy (gold plated)

CONTACT RESISTANCE
Before Life: 100 milliohms max. (measured @ 10 mA @ 6 Vdc)

After Life: 200 milliohms max. (measured @ 1 A @ 28 Vdc)

MECHANICAL LIFE EXPECTANCY
1 million operations

COIL VOLTAGE
5 to 48 Vdc

COIL POWER
565 mW max. @ 25°C

DUTY CYCLE
Continuous

PICK-UP VOLTAGE
Approximately 50% of nominal coil voltage

PICK-UP SENSITIVITY
60 mW max. @ 25°C

CONTACT RATINGS

CONTACT LOAD	TYPE	OPERATIONS MIN.
1.0 A @ 28 Vdc	Resistive	100,000
250 mA @ 115 Vac, 60 Hz & 400 Hz	Resistive (case not grounded)	100,000
100 mA @ 115 Vac, 60 Hz & 400 Hz	Resistive	100,000
0.2 A @ 28 Vdc	Inductive (0.32 Henry)	100,000
0.1 A @ 28 Vdc	Lamp	100,000
30 µA @ 50 mVdc	Low Level	1,000,000
0.1 A @ 28 Vdc	Intermediate Current	50,000

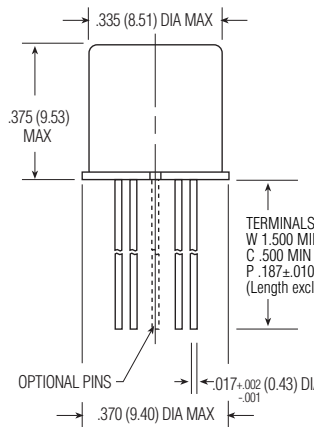

ENCLOSURE

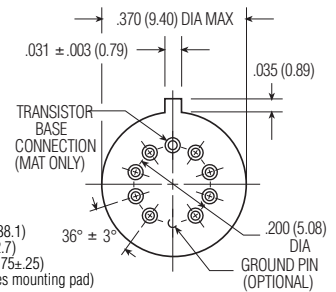

HEADER



OPERATING CHARACTERISTICS

TIMING

Operate Time:
4.0 ms max.

Release Time:
MS: 2.0 ms max.
MSD/MSDD: 7.5 ms max.
(suppression diode,
suppression/steering diodes)
MST: 7.5 ms max .
(transistor driven)

CONTACT BOUNCE

1.5 ms max

DIELECTRIC WITHSTANDING VOLTAGE

Between Open Contacts:
500 Vrms 60 Hz

Between Adjacent Contacts:
500 Vrms 60 Hz

Between Contacts & Coil:
500 Vrms 60 Hz

INSULATION RESISTANCE

10,000 megohms min. @ 500 Vdc
1,000 megohms @ 500 Vdc
(coil to case @ +125°C)

ENVIRONMENTAL CHARACTERISTICS

TEMPERATURE RANGE

-65°C to +125°C

WEIGHT

0.12 oz. (3.40 gms)
0.13 oz. (3.45 gms) with spreader
pad attached

VIBRATION RESISTANCE

30 G's, 10 to 3,000 Hz

SHOCK RESISTANCE

75 G's, 6 ±1 ms max.

QPL APPROVAL

MIL-R-39016/11 (JMS)
MIL-R-39016/16 (JMSSD)
MIL-R-39016/21 (JMSSDD)
MIL-R-28776/3 (JMST)

SEMICONDUCTOR CHARACTERISTICS

DIODE

100 Vdc peak inverse voltage (PIV)
1.0 Vdc max. transient voltage

TRANSISTOR

0.3 Vdc min. base turn off voltage
6.0 Vdc min. emitter-base
breakdown voltage (BV_{EBO}) @ 25°C
80.0Vdc min. collector-base
breakdown voltage (BV_{CBO}) @ 25°C
& I_C=100 µA

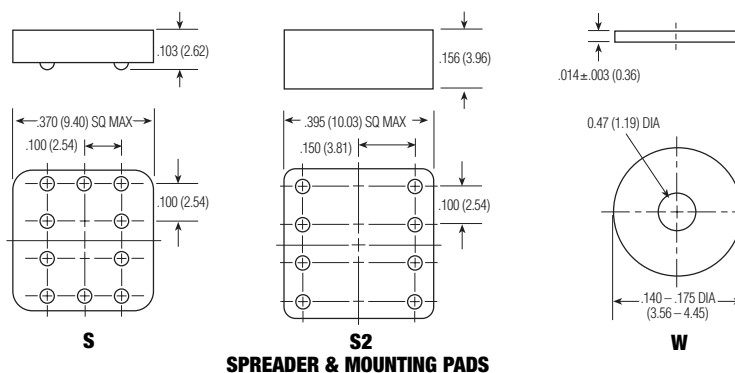

COIL DATA

NOM. COIL VOLTAGE (Vdc)	COIL RESISTANCE IN OHMS ±10% @ 25°C (Note 1)	COIL CIRCUIT CURRENT mA (MAX.) (Note 1&2)	COIL CIRCUIT CURRENT mA (MIN.) (Note 1&2)	PICKUP VOLTAGE Vdc (MAX.) @ 25°C (Note 2)	BASE TURN ON CURRENT mA (MAX.) @ 25°C	PICKUP VOLTAGE Vdc (MAX.) @ 125°C (Note 2)	BASE TURN ON CURRENT mA (MAX.) @ 125°C	DROP-OUT VOLTAGE Vdc (MIN.) @ 25°C (Note 2)	DROP-OUT VOLTAGE Vdc (MIN.) @ -65°C (Note 2)	NOM. COIL POWER (mW) @ 25°C	MAX. COIL VOLTAGE	COIL DESIG.
MS/MSD												
5.0	100	n/a	n/a	2.6	n/a	3.5	n/a	0.23	0.12	250	7.5	5
6.0	200	n/a	n/a	3.4	n/a	4.5	n/a	0.28	0.18	180	10.0	6
9.0	400	n/a	n/a	4.85	n/a	6.8	n/a	0.55	0.35	203	15.0	9
12.0	850	n/a	n/a	7.0	n/a	9.0	n/a	0.64	0.41	169	20.0	12
18.0	1,600	n/a	n/a	9.8	n/a	13.5	n/a	0.92	0.59	203	30.0	18
26.5	3,300	n/a	n/a	14.0	n/a	18.0	n/a	1.4	0.89	213	40.0	26
36.0	6,500	n/a	n/a	20.0	n/a	27.0	n/a	1.8	1.25	199	57.0	36
48.0	11,000	n/a	n/a	25.8	n/a	36.0	n/a	2.4	1.60	209	75.0	48
MSDD												
5.0	64	78.1	56.8	2.9	n/a	3.7	n/a	0.8	0.7	391	7.0	5
6.0	125	48.9	36.3	4.0	n/a	4.8	n/a	0.9	0.8	288	10.0	6
9.0	400	23.6	18.1	6.1	n/a	8.0	n/a	1.1	0.9	203	15.0	9
12.0	850	15.0	11.7	7.8	n/a	11.0	n/a	1.3	1.0	169	20.0	12
18.0	1,600	12.2	9.6	11.3	n/a	14.5	n/a	1.5	1.1	203	30.0	18
26.5	3,300	8.8	7.0	15.2	n/a	19.0	n/a	1.7	1.3	213	40.0	26
36.0	6,500	6.1	4.9	21.7	n/a	27.2	n/a	2.3	1.7	199	57.0	36
48.0	11,000	4.8	3.9	27.8	n/a	34.8	n/a	2.8	2.0	209	75.0	48
MST												
5.0	100	59.3	43.5	2.8	0.37	3.6	1.50	0.22	0.14	250	7.0	5
6.0	200	35.4	26.4	3.8	0.25	4.8	1.00	0.28	0.18	180	10.0	6
9.0	400	25.8	19.7	5.2	0.18	7.8	0.75	0.54	0.35	203	15.0	9
12.0	850	16.7	12.2	7.4	0.12	11.0	0.47	0.63	0.41	169	20.0	12
18.0	1,600	13.1	9.7	10.0	0.09	14.5	0.38	0.91	0.59	203	30.0	18
26.5	3,300	9.5	6.9	14.2	0.06	19.0	0.24	1.37	0.89	213	40.0	26
36.0	6,500	6.4	4.8	20.0	0.034	27.0	0.17	1.80	1.25	199	57.0	36
48.0	11,000	5.1	3.7	25.8	0.026	36.0	0.13	2.40	1.60	209	75.0	48

Note 1: Coil resistance not directly measurable. Coil current should be within limits shown when tested at nominal voltage at 25°C for 5 seconds max.
Note 2: Set base current at 3 mA to 15 mA during measurements.

SPECIFYING A PART NUMBER EXAMPLE:	TYPE	TERMINALS	DIODES	GROUND PINS	COILS	SPREADER/MOUNTING PADS
	MS	C	D	G	-26	S





Product Facts

- Bi-directional power FET output.
- Optically coupled.
- Low on-resistance.
- Extremely low leakage current.
- Subminiature hermetically sealed package.
- Tested per MIL-R-28750 and approved to DSCC drawing 89116-006.

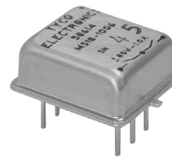

The MS18-1006 is an optically coupled SSR employing power MOSFET output chips in an inverse series configuration for switching DC or bi-directional loads. A common source connection is provided for the user to

configure the output switching circuit for DC operation up to 2A with very low on-resistance. The relay features fast switching speeds, low off-state leakage, virtually zero offset voltage and the capability to

withstand high inrush currents up to 350% of rated. The low profile subminiature package is hermetically sealed with pinouts on a 0.1" x 0.3" grid pattern.

CII Part No.	DSCC Dwg. No.	Relay Version
MS18-1006	89116-006	Basic relay

Environmental Characteristics

Ambient Temperature Range:
 Operating: -55°C to +120°C.
 Storage: -55°C to +125°C.

Vibration Resistance:
 100 G's, 10-2,000 Hz.

Shock Resistance:
 1,500 G's, 0.5 ms pulse.

Constant Acceleration Resistance (Y-1 axis):
 5,000 G's.

Mechanical Characteristics

Weight (approx.):
 .07 oz. (5 grams)

Materials:
 Header: Kovar
 Cover: Grade A Nickel
 Pins: Kovar, gold plated

Electrical Specifications (-55°C to +120°C unless otherwise specified)

Input	
Input current (max.)	25mA _{dc}
Input voltage drop (max. @ 25mA)	1.5 V _{dc}
Must turn-on current	10mA
Must turn-off current	10µA
Reverse voltage protection	-5.0V _{dc}
I/O	
Dielectric strength (60Hz., 1mA leakage)	500V rms
Insulation resistance (min.) @ 500V _{dc}	10 ⁹ ohms
Capacitance (max. @ 25V _{dc} , 1 Mhz)	5pF
Output	
Continuous load current, parallel (DC) configuration (max.)	2A
Continuous load current, series (bi-directional) configuration (max.)	1A
Continuous operating load voltage (max.)	+/- 80V
Transient blocking voltage (5 sec max.)	+/- 90V
Overload (100ms, 10% duty cycle, 10 cycles max.)	350% of rated
dv/dt (min.)	100V / µs
On resistance (max.), parallel (DC) configuration	0.4 ohm
On resistance (max.), series (bi-directional) configuration	0.6 ohm
Thermal resistance, junction to ambient	110°C/W
Thermal resistance, junction to case	20°C/W

Figure 1 – Wiring Diagrams



© 2004 by Tyco Electronics Corporation. All Rights Reserved.
 CII and TYCO are trademarks.

Figure 2 - Temperature Derating Curves

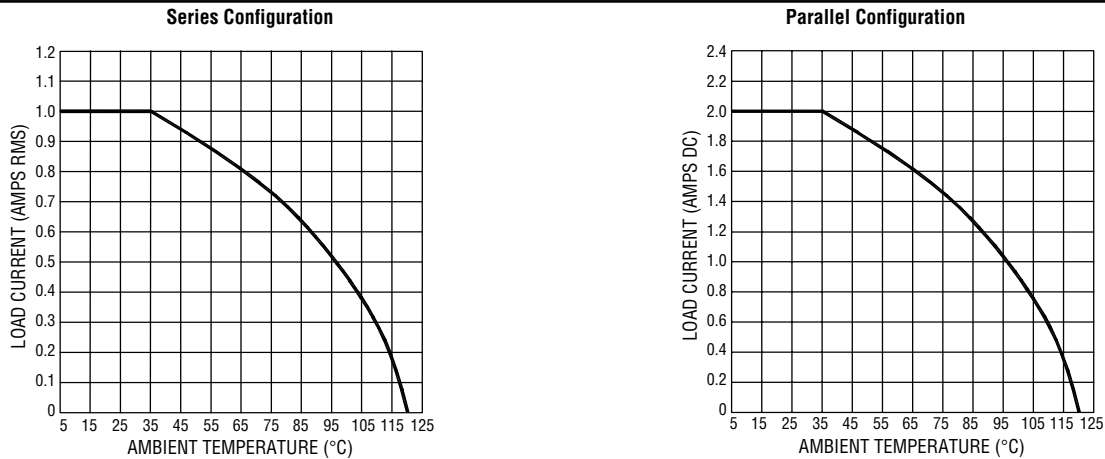

Figure 3 - Turn-on and Turn-off Timing

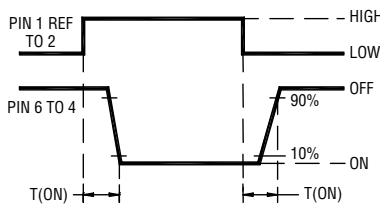

Figure 4 - Functional Block Diagram

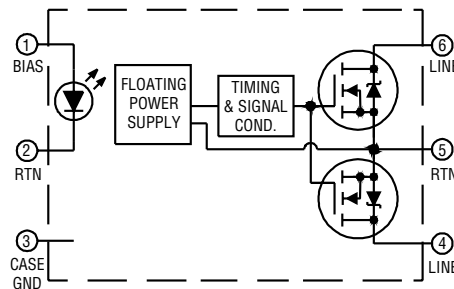
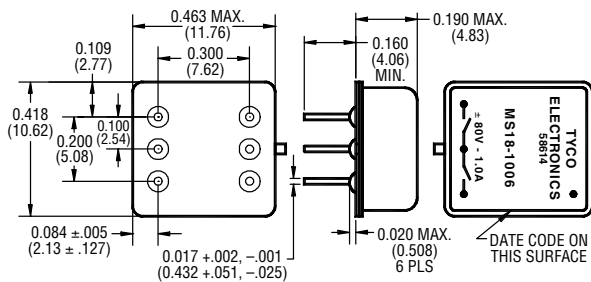

Figure 5 - Outline Dimensions



Notes

1. An external resistor must be in series with the input at all times.
2. Do not ramp input current. Input transition should be <1.0ms.
3. Input current/series resistor calculation (Approx.): $I_{(input)} = \frac{V_{IN} - V_{DROP}}{R_{SERIES}}$
4. Unless otherwise specified parametric testing is accomplished at 25ma input current.
5. To calculate $R_{DS(ON)}$ for temperatures other than 25°C, use the following equation: $T_{(TEMP)} = (R_{DS(ON)} \text{ at } + 25^{\circ}C) \cdot e^{(X \cdot \Delta T)}$ where $x = 0.0065$.
6. Inductive loads must be diode suppressed.
7. Continuous load current is rated under conditions of still air.
8. Load may be connected to either side of relay, sink or source modes.
9. Reverse polarity >5Vdc may cause permanent damage
10. Acceptance testing is accomplished in the series (bi-directional) mode.

MS18-TBD-PDF-KRG-1-04

MGS · MGSD · MGSDD · MGST

.100 GRID HIGH-PERFORMANCE RELAYS

MGS

**SENSITIVE .100 GRID
HIGH-PERFORMANCE RELAY**

**QUALIFIED TO
MIL-R-39016/41**

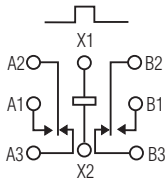

TERMINAL VIEW

FEATURES

- Hermetically sealed
- High shock & vibration ratings
- Mounting pads
- Excellent RF switching

MGSD

**SENSITIVE .100 GRID
DIODE SUPPRESSED
HIGH-PERFORMANCE RELAY**

**QUALIFIED TO
MIL-R-39016/42**

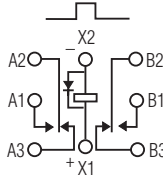

TERMINAL VIEW

FEATURES

- Suppression diode
- Hermetically sealed
- High shock & vibration ratings
- Mounting pads
- Excellent RF switching

MGSDD

**SENSITIVE .100 GRID DIODE
SUPPRESSED/PROTECTED
HIGH-PERFORMANCE RELAY**

**QUALIFIED TO
MIL-R-39016/43**

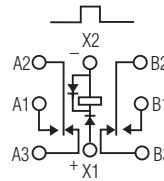

TERMINAL VIEW

FEATURES

- Suppression & protection diodes
- Hermetically sealed
- High shock & vibration ratings
- Mounting pads
- Excellent RF switching

MGST

**SENSITIVE .100 GRID DIODE
SUPPRESSED/MOSFET
DRIVEN HIGH-PERFORMANCE
RELAY**

**QUALIFIED TO
MIL-R-28776/7**

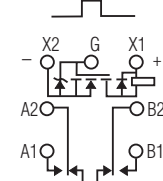

TERMINAL VIEW

FEATURES

- MOSFET driver, zener & suppression diodes
- Hermetically sealed
- High shock & vibration ratings
- Mounting pads
- Excellent RF switching

ELECTRICAL CHARACTERISTICS

CONTACT ARRANGEMENT

2 Form C (DPDT)

CONTACT MATERIAL

Stationary:
Gold/platinum/palladium/silver
(gold plated)

Moveable:

Gold/platinum/palladium/silver
(gold plated)

CONTACT RESISTANCE

Before Life: 100 milliohms max.
(measured @ 10 mA @ 6 Vdc)

After Life: 200 milliohms max.
(measured @ 1 A @ 28 Vdc)

MECHANICAL LIFE EXPECTANCY

1 million operations

COIL VOLTAGE

5 to 48 Vdc

COIL POWER

565 mW max. @ 25°C

DUTY CYCLE

Continuous

PICK-UP VOLTAGE

Approximately 50% of
nominal coil voltage

PICK-UP SENSITIVITY

60 mW max. @ 25°C

CONTACT RATINGS

CONTACT LOAD	TYPE	OPERATIONS MIN.
1.0 A @ 28 Vdc	Resistive	100,000
250 mA @ 115 Vac, 60 Hz & 400 Hz	Resistive (case not grounded)	100,000
100 mA @ 115 Vac, 60 Hz & 400 Hz	Resistive	100,000
0.2 A @ 28 Vdc	Inductive (0.32 Henry)	100,000
0.1 A @ 28 Vdc	Lamp	100,000
30 µA @ 50 mVdc	Low Level	1,000,000
0.1 A @ 28 Vdc	Intermediate Current	50,000



MGS

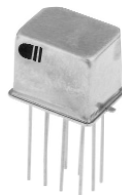

MGST

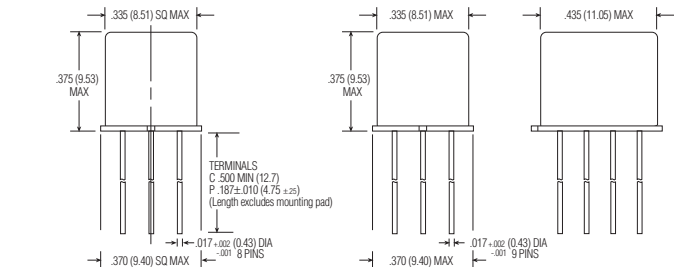

MGS/MGSD/MGSDD ENCLOSURE

MGST ENCLOSURE

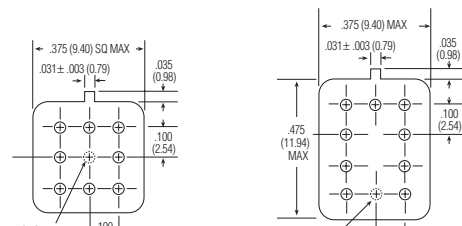

MGS/MGSD/MGSDD HEADER

MGST HEADER

OPERATING CHARACTERISTICS

TIMING

Operate Time:
4.0 ms max.

Release Time:
MGS: 2.0 ms max.
MGSD/MGSDD: 7.5 ms max.
(suppression diode, protection/suppression diodes)
MGST: 7.5 ms max.
(suppression/zener diodes)

CONTACT BOUNCE

1.5 ms max.

DIELECTRIC WITHSTANDING VOLTAGE

Between Open Contacts:
500 Vrms 60 Hz

Between Adjacent Contacts:
500 Vrms 60 Hz

Between Contacts & Coil:
500 Vrms 60 Hz

INSULATION RESISTANCE

10,000 megohms min. @ 500 Vdc
1,000 megohms @ 500 Vdc
(coil to case @ +125°C)

ENVIRONMENTAL CHARACTERISTICS

TEMPERATURE RANGE

-65°C to +125°C

WEIGHT

0.09 oz. (2.55 gms)
0.129 oz. (3.45 gms) w/ mounting pad attached

VIBRATION RESISTANCE

30 G's, 10 to 3,000 Hz

SHOCK RESISTANCE

75 G's, 6 ±1 ms max.

QPL APPROVAL

MIL-R-39016/41 (JMGS)
MIL-R-39016/42 (JMGSDD)
MIL-R-39016/43 (JMGSDD)
MIL-R-28776/7 (JMGSST)

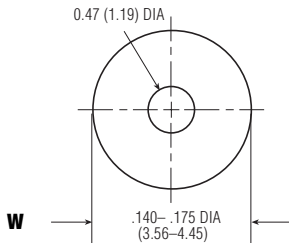
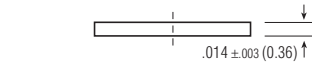

MGS/MGSD/MGSDD MOUNTING PAD

SEMICONDUCTOR CHARACTERISTICS

DIODE

100 Vdc peak inverse voltage (PIV)
1.0 Vdc max. transient voltage

ZENER DIODE

20 Vdc ±3 Vdc over temperature range

MOSFET

0.5 Vdc min. gate turn off voltage
4.3 Vdc max. gate turn on voltage

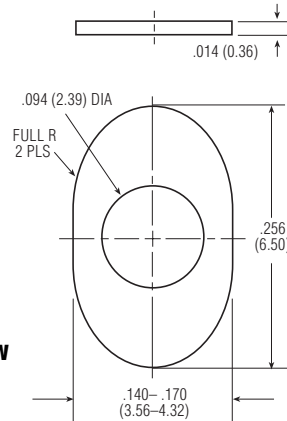

MGST MOUNTING PAD

COIL DATA

NOM. COIL VOLTAGE (Vdc)	COIL RESISTANCE IN OHMS ±10% @ 25°C (Note)	COIL CIRCUIT CURRENT mA (MAX.) (Note)	COIL CIRCUIT CURRENT mA (MIN.) (Note)	PICKUP VOLTAGE Vdc (MAX.) @ 25°C	PICKUP VOLTAGE Vdc (MAX.) @ 125°C	DROP-OUT VOLTAGE Vdc (MIN.) @ 25°C	DROP-OUT VOLTAGE Vdc (MIN.) @ -65°C	NOM. COIL POWER (mW) @ 25°C	MAX. COIL VOLTAGE	COIL DESIG.
MGS/MGSD										
5.0	100	n/a	n/a	2.6	3.5	0.23	0.12	250	7.5	5
6.0	200	n/a	n/a	3.4	4.5	0.28	0.18	180	10.0	6
9.0	400	n/a	n/a	4.85	6.8	0.55	0.35	203	15.0	9
12.0	800	n/a	n/a	7.0	9.0	0.64	0.41	180	20.0	12
18.0	1,600	n/a	n/a	9.8	13.5	0.92	0.59	203	30.0	18
26.5	3,200	n/a	n/a	14.0	18.0	1.4	0.89	219	40.0	26
36.0	6,500	n/a	n/a	20.0	27.0	1.8	1.25	199	57.0	36
48.0	11,000	n/a	n/a	25.8	36.0	2.4	1.60	209	75.0	48
MGSDD										
5.0	64	78.1	56.8	2.9	3.7	0.8	0.7	391	7.5	5
6.0	125	48.9	36.3	4.0	4.8	0.9	0.8	288	10.0	6
9.0	400	23.6	18.1	6.1	8.0	1.1	0.9	203	15.0	9
12.0	800	16.0	12.5	7.8	11.0	1.3	1.0	180	20.0	12
18.0	1,600	12.2	9.6	11.3	14.5	1.5	1.1	203	30.0	18
26.5	3,200	9.0	7.2	15.2	19.0	1.7	1.3	219	40.0	26
36.0	6,500	6.1	4.9	21.7	27.2	2.3	1.7	199	57.0	36
48.0	11,000	4.8	3.9	27.8	34.8	2.8	2.0	209	75.0	48
MGST										
5.0	100	56.0	43.0	2.9	4.0	0.23	0.13	250	5.6	5
6.0	200	33.0	27.0	3.5	4.9	0.32	0.18	180	8.0	6
9.0	400	26.4	17.8	5.3	7.3	0.48	0.27	203	12.0	9
12.0	800	17.7	11.3	7.1	9.8	0.65	0.36	180	16.0	12
18.0	1,600	13.8	8.4	10.6	14.6	0.97	0.54	203	24.0	18
26.5	3,200	10.2	5.8	14.2	19.5	1.30	0.72	219	32.0	26

Note: Coil resistance not directly measurable. Coil current should be within limits shown when tested at nominal voltage at 25°C for 5 seconds max.

SPECIFYING A PART NUMBER EXAMPLE:

TYPE MGS **TERMINALS** C **DIODES TRANSISTOR** D **GROUND PINS** G **COILS** -26 **MOUNTING PADS** W



MGA · MGAD · MGADD · MGAT

.100 GRID HIGH-PERFORMANCE RELAYS

MGA

**STANDARD .100 GRID
HIGH-PERFORMANCE RELAY**

**QUALIFIED TO
MIL-R-39016/17**

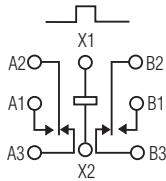

TERMINAL VIEW

FEATURES

- Hermetically sealed
- High shock & vibration ratings
- Mounting pads
- Excellent RF switching

MGAD

**STANDARD .100 GRID
DIODE SUPPRESSED
HIGH-PERFORMANCE RELAY**

**QUALIFIED TO
MIL-R-39016/18**

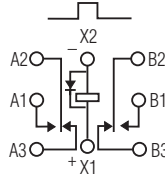

TERMINAL VIEW

FEATURES

- Suppression diode
- Hermetically sealed
- High shock & vibration ratings
- Mounting pads
- Excellent RF switching

MGADD

**STANDARD .100 GRID DIODE
SUPPRESSED/PROTECTED
HIGH-PERFORMANCE RELAY**

**QUALIFIED TO
MIL-R-39016/19**

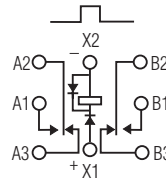

TERMINAL VIEW

FEATURES

- Suppression & protection diodes
- Hermetically sealed
- High shock & vibration ratings
- Mounting pads
- Excellent RF switching

MGAT

**STANDARD .100 GRID DIODE
SUPPRESSED/MOSFET DRIVEN
HIGH-PERFORMANCE RELAY**

**QUALIFIED TO
MIL-R-28776/6**

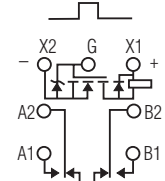

TERMINAL VIEW

FEATURES

- MOSFET driver, zener & suppression diodes
- Hermetically sealed
- High shock & vibration ratings
- Mounting pads
- Excellent RF switching

ELECTRICAL CHARACTERISTICS

CONTACT ARRANGEMENT
2 Form C (DPDT)

CONTACT MATERIAL
Stationary:
Gold/platinum/palladium/silver
(gold plated)
Moveable:
Gold/platinum/palladium/silver
(gold plated)

CONTACT RESISTANCE
Before Life: 100 milliohms max.
(measured @ 10 mA @ 6 Vdc)
After Life: 200 milliohms max.
(measured @ 1 A @ 28 Vdc)

MECHANICAL LIFE EXPECTANCY
1 million operations

COIL VOLTAGE
5 to 26.5 Vdc

COIL POWER
660 mW max. @ 25°C

DUTY CYCLE
Continuous

PICK-UP VOLTAGE
Approximately 50% of
nominal coil voltage

PICK-UP SENSITIVITY
130 mW max. @ 25°C

CONTACT RATINGS

CONTACT LOAD	TYPE	OPERATIONS MIN.
1.0 A @ 28 Vdc	Resistive	100,000
250 mA @ 115 Vac, 60 Hz & 400 Hz	Resistive (case not grounded)	100,000
100 mA @ 115 Vac, 60 Hz & 400 Hz	Resistive	100,000
0.2 A @ 28 Vdc	Inductive (0.32 Henry)	100,000
0.1 A @ 28 Vdc	Lamp	100,000
30 µA @ 50 mVdc	Low Level	1,000,000
0.1 A @ 28 Vdc	Intermediate Current	50,000

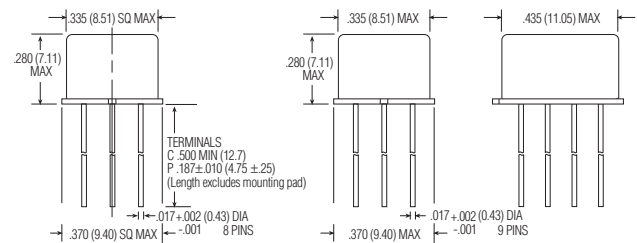

MGA/MGAD/MGADD ENCLOSURE

MGAT ENCLOSURE



MGA



MGAT

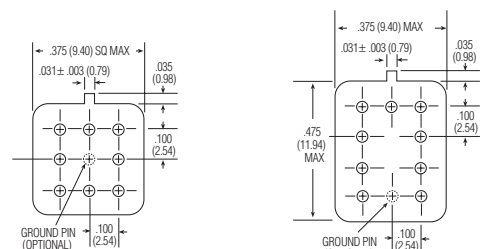

MGA/MGAD/MGADD HEADER

MGAT HEADER

OPERATING CHARACTERISTICS

TIMING

Operate Time:
2.0 ms max.

Release Time:
MGA: 1.5 ms max.
MGAD/MGADD: 4.0 ms max.
(suppression diode, protection/sup-
pression diodes)
MGAT: 4.0 ms max.
(suppression/zener diodes)

CONTACT BOUNCE

1.5 ms max.

DIELECTRIC WITHSTANDING VOLTAGE

Between Open Contacts:
500 Vrms 60 Hz

Between Adjacent Contacts:
500 Vrms 60 Hz

Between Contacts & Coil:
500 Vrms 60 Hz

INSULATION RESISTANCE

10,000 megohms min. @ 500 Vdc
1,000 megohms @ 500 Vdc
(coil to case @ +125°C)

ENVIRONMENTAL CHARACTERISTICS

TEMPERATURE RANGE

-65°C to +125°C

WEIGHT

0.09 oz. (2.55 gms)
0.129 oz. (3.45 gms) w/ mounting
pad attached

VIBRATION RESISTANCE

30 G's, 10 to 3,000 Hz

SHOCK RESISTANCE

75 G's, 6 ± 1 ms max.

QPL APPROVAL

MIL-R-39016/17 (JMGA)
MIL-R-39016/18 (JMGAD)
MIL-R-39016/19 (JMGADD)
MIL-R-28776/6 (JMGAT)

SEMICONDUCTOR CHARACTERISTICS

DIODE

100 Vdc peak inverse voltage (PIV)
1.0 Vdc max. transient voltage

ZENER DIODE

20 Vdc ±3 Vdc over temperature
range

MOSFET

0.5 Vdc min. gate turn-off voltage
4.3 Vdc max. gate turn-on voltage

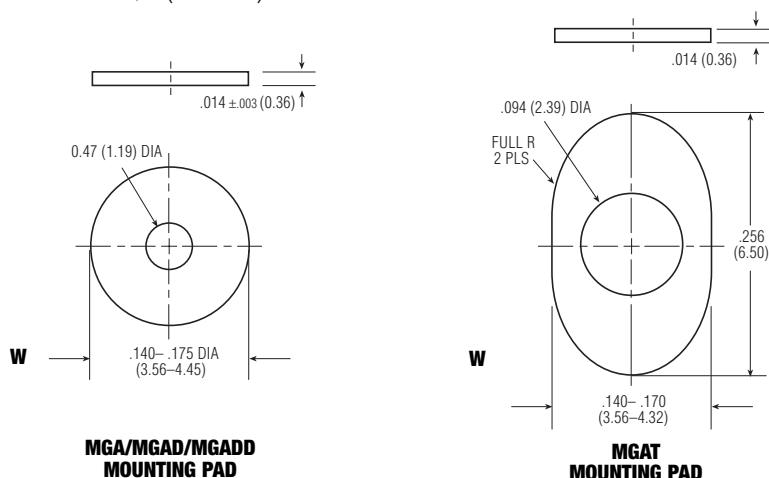

COIL DATA

NOM. COIL VOLTAGE (Vdc)	COIL RESISTANCE IN OHMS ±10% @ 25°C (Note)	COIL CIRCUIT CURRENT mA (MAX.) (Note)	COIL CIRCUIT CURRENT mA (MIN.) (Note)	PICKUP VOLTAGE Vdc (MAX.) @ 25°C	PICKUP VOLTAGE Vdc (MAX.) @ 125°C	DROP-OUT VOLTAGE Vdc (MIN.) @ 25°C	DROP-OUT VOLTAGE Vdc (MIN.) @ -65°C	NOM. COIL POWER (mW) @ 25°C	MAX. COIL VOLTAGE	COIL DESIG.
MGA/MGAD										
5.0	50	n/a	n/a	2.7	3.5	0.22	0.14	500	5.8	5
6.0	98	n/a	n/a	3.5	4.5	0.28	0.18	367	8.0	6
9.0	220	n/a	n/a	5.3	6.8	0.54	0.35	368	12.0	9
12.0	390	n/a	n/a	7.0	9.0	0.63	0.41	369	16.0	12
18.0	880	n/a	n/a	10.5	13.5	0.91	0.59	368	24.0	18
26.5	1,560	n/a	n/a	14.2	18.0	1.37	0.89	450	32.0	26
MGADD										
5.0	39	128.2	93.2	3.2	4.0	0.6	0.6	641	5.8	5
6.0	78	78.3	58.3	4.0	5.0	0.7	0.7	462	8.0	6
9.0	220	42.9	33.0	6.3	7.8	0.9	0.8	368	12.0	9
12.0	390	32.8	25.6	8.0	10.0	1.1	0.9	369	16.0	12
18.0	880	22.1	17.5	11.5	14.5	1.4	1.1	368	24.0	18
26.5	1,560	18.5	14.8	15.2	19.0	1.8	1.4	450	32.0	26
MGAT										
5.0	39	132.3	96.5	2.9	3.5	0.23	0.13	641	5.8	5
6.0	78	83.9	60.3	3.5	4.5	0.32	0.18	462	8.0	6
9.0	220	47.1	33.1	5.3	6.8	0.48	0.27	368	12.0	9
12.0	390	36.1	24.9	7.1	9.0	0.65	0.36	369	16.0	12
18.0	880	24.1	16.1	10.6	13.5	0.97	0.54	368	24.0	18
26.5	1,560	19.9	12.9	14.2	18.0	1.30	0.72	450	32.0	26

Note: Coil resistance not directly measurable. Coil current should be within limits shown when tested at nominal voltage at 25°C for 5 seconds max.

SPECIFYING A PART NUMBER EXAMPLE: TYPE MGA TERMINALS C DIODES TRANSISTOR D GROUND PINS G COILS -26 MOUNTING PADS W



MFW · RD · RFK · RFB

MFW · RD · RFK · RFB HIGH PERFORMANCE RELAYS

MFW

1/6 SIZE HIGH PERFORMANCE RELAY

QUALIFIED TO MIL-R-39016/34



FEATURES

- Hermetically sealed
- Compact size
- Optional terminals & mounting options
- Excellent RF switching

ELECTRICAL CHARACTERISTICS

CONTACT ARRANGEMENT

2 Form C (DPDT)

CONTACT RATINGS

Low level to 2 A @ 28 Vdc resistive

COIL VOLTAGE

3.5 to 53 Vdc

NOMINAL COIL POWER

450 mW

ENVIRONMENTAL CHARACTERISTICS

TEMPERATURE

-65°C to +125°C

SHOCK

100 G's, 6 ms

VIBRATION

20 G's, 10 to 2000 Hz

QPL APPROVAL

M39016/34

RD·02·03

TWO, FOUR & SIX POLE HIGH PERFORMANCE RELAY

QUALIFIED TO MIL-R-5757/1, 7 & 8



FEATURES

- Hermetically sealed
- Multi-pole configurations
- Optional terminals & mounting options

ELECTRICAL CHARACTERISTICS

CONTACT ARRANGEMENT

02: 2 Form C (DPDT)
RD4: 4 Form C (4PDT)
RD6, 03: 6 Form C (6PDT)

CONTACT RATINGS

Low level to 2 A @ 28 Vdc resistive

COIL VOLTAGE

6 to 26.5 Vdc

NOMINAL COIL POWER

02: 450 mW
RD4: 2 W
RD6, 03: 3 W

ENVIRONMENTAL CHARACTERISTICS

TEMPERATURE

-65°C to +125°C

SHOCK

100 G's, 6 ms

VIBRATION

20 G's, 10 to 2000 Hz

QPL APPROVAL

RD6: M5757/1
RD4: M5757/7
02: M5757/8

RFK

HALF SIZE RF COAXIAL HIGH PERFORMANCE RELAY

DESIGNED TO MIL-R-5757



FEATURES

- Hermetically sealed
- Coaxial cables
- Optional terminals & mounting options
- Optional auxiliary contacts
- Excellent RF switching

ELECTRICAL CHARACTERISTICS

CONTACT ARRANGEMENT

2 Form C (DPDT) coaxial
or
1 Form C (SPDT) coaxial & 1 Form C (SPDT) auxiliary contacts

CONTACT RATINGS

75 W RF (Switching)
200 W RF (Carry)
Low level to 2 Amps @ 28 Vdc resistive

COIL VOLTAGE

6 to 26.5 VDC

NOMINAL COIL POWER

1 W

ENVIRONMENTAL CHARACTERISTICS

TEMPERATURE

-65°C to +85°C

SHOCK

100 G's, 6 ms

VIBRATION

20 G's, 10 to 2000 Hz

RFB

FULL SIZE RF COAXIAL HIGH PERFORMANCE RELAY

DESIGNED TO MIL-R-5757



FEATURES

- Hermetically sealed
- Coaxial cables
- Optional terminals & mounting options
- Optional auxiliary contacts
- Excellent RF switching

ELECTRICAL CHARACTERISTICS

CONTACT ARRANGEMENT

2 Form C (DPDT) coaxial
or
1 Form C (SPDT) coaxial & 1 Form C (SPDT) auxiliary contacts

CONTACT RATINGS

75 W RF (Switching)
200 W RF (Carry)
Low level to 2 A @ 28 Vdc resistive

COIL VOLTAGE

6 to 26.5 Vdc

NOMINAL COIL POWER

1 W

ENVIRONMENTAL CHARACTERISTICS

TEMPERATURE

-65°C to +85°C

SHOCK

100 G's, 6 ms

VIBRATION

20 G's, 10 to 2000 Hz

MA · MAD · MADD · MAT

MA

**STANDARD TO-5
HIGH-PERFORMANCE RELAY**

**QUALIFIED TO
MIL-R-39016/9**

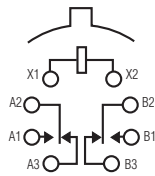

TERMINAL VIEW

FEATURES

- Hermetically sealed
- High shock & vibration ratings
- Spreader pads
- Excellent RF switching

MAD

**STANDARD TO-5
DIODE SUPPRESSED
HIGH-PERFORMANCE RELAY**

**QUALIFIED TO
MIL-R-39016/15**

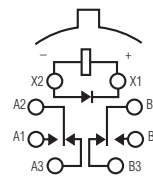

TERMINAL VIEW

FEATURES

- Suppression diode
- Hermetically sealed
- High shock & vibration ratings
- Spreader pads
- Excellent RF switching

MADD

**STANDARD TO-5 DIODE
SUPPRESSED/PROTECTED
HIGH-PERFORMANCE RELAY**

**QUALIFIED TO
MIL-R-39016/20**

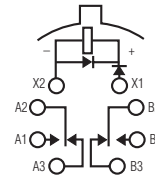

TERMINAL VIEW

FEATURES

- Suppression & protection diodes
- Hermetically sealed
- High shock & vibration ratings
- Spreader pads
- Excellent RF switching

MAT

**STANDARD TO-5 DIODE
SUPPRESSED/TRANSISTOR DRIVEN
HIGH-PERFORMANCE RELAY**

**QUALIFIED TO
MIL-R-28776/1**

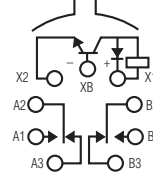

TERMINAL VIEW

FEATURES

- Transistor driver & suppression diode
- Hermetically sealed
- High shock & vibration ratings
- Spreader pads
- Excellent RF switching

ELECTRICAL CHARACTERISTICS

CONTACT ARRANGEMENT
2 Form C (DPDT)

CONTACT MATERIAL
Stationary:
Gold/platinum/palladium/silver alloy (gold plated)
Moveable:
Gold/platinum/palladium/silver alloy (gold plated)

CONTACT RESISTANCE
Before Life: 100 milliohms max. (measured @ 10 mA @ 6 Vdc)
After Life: 200 milliohms max. (measured @ 1 A @ 28 Vdc)

MECHANICAL LIFE EXPECTANCY
1 million operations

COIL VOLTAGE
5 to 30 Vdc

COIL POWER
675 mW max. @ 25°C

DUTY CYCLE
Continuous

PICK-UP VOLTAGE
Approximately 50% of nominal coil voltage

PICK-UP SENSITIVITY
130 mW max. @ 25°C

CONTACT RATINGS

CONTACT LOAD	TYPE	OPERATIONS MIN.
1.0 A @ 28 Vdc	Resistive	100,000
250 mA @ 115 Vac, 60 Hz & 400 Hz	Resistive (case not grounded)	100,000
100 mA @ 115 Vac, 60 Hz & 400 Hz	Resistive	100,000
0.2 A @ 28 Vdc	Inductive (0.32 Henry)	100,000
0.1 A @ 28 Vdc	Lamp	100,000
30 μA @ 50 mVdc	Low Level	1,000,000
0.1 A @ 28 Vdc	Intermediate Current	50,000

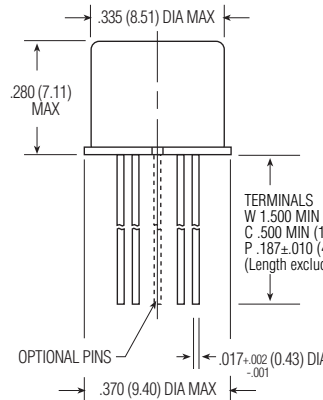

ENCLOSURE

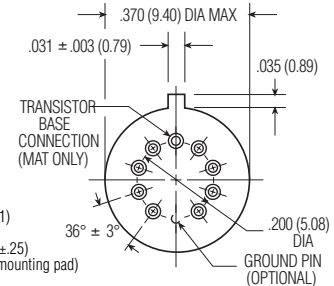

HEADER

TO-5 HIGH-PERFORMANCE RELAYS



OPERATING CHARACTERISTICS

TIMING

Operate Time:
2.0 ms max.

Release Time:
MA: 1.5 ms max.
MAD/MADD: 4.0 ms max.
(suppression diode,
suppression/steering diodes)
MAT: 7.5 ms max.
(transistor driven)

CONTACT BOUNCE

1.5 ms max

DIELECTRIC WITHSTANDING VOLTAGE

Between Open Contacts:
500 Vrms 60 Hz

Between Adjacent Contacts:
500 Vrms 60 Hz

Between Contacts & Coil:
500 Vrms 60 Hz

INSULATION RESISTANCE

10,000 megohms min. @ 500 Vdc
1,000 megohms @ 500 Vdc
(coil to case @ +125°C)

ENVIRONMENTAL CHARACTERISTICS

TEMPERATURE RANGE

-65°C to +125°C

WEIGHT

0.09 oz. (2.55 gms)
0.10 oz. (2.80 gms) with spreader
pad attached

VIBRATION RESISTANCE

30 G's, 10 to 3,000 Hz

SHOCK RESISTANCE

75 G's, 6 ±1 ms max.

QPL APPROVAL

MIL-R-39016/9 (JMA)
MIL-R-39016/15 (JMAD)
MIL-R-39016/20 (JMADD)
MIL-R-28776/1 (JMAT)

SEMICONDUCTOR CHARACTERISTICS

DIODE

100 Vdc peak inverse voltage (PIV)
1.0 Vdc max. transient voltage

TRANSISTOR

0.3 Vdc min. base turn off voltage
6.0 Vdc min. emitter-base
breakdown voltage (BV_{EBO}) @ 25°C
80.0 Vdc min. collector-base
breakdown voltage (BV_{CBO}) @ 25°C
& I_C=100 µA

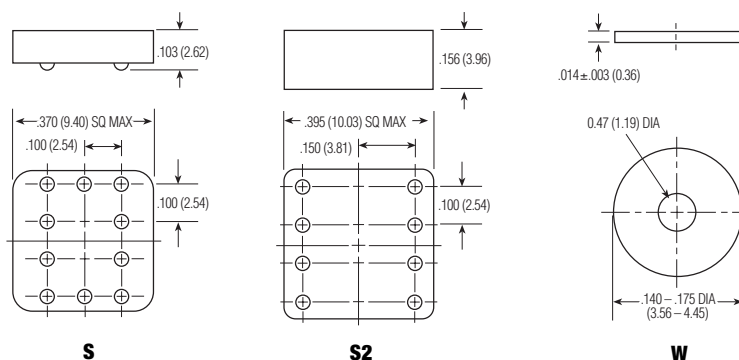

SPREADER & MOUNTING PADS

COIL DATA

NOM. COIL VOLTAGE (Vdc)	COIL RESISTANCE IN OHMS ±10% @ 25°C (Note 1)	COIL CIRCUIT CURRENT mA (MAX.) (Note 1&2)	COIL CIRCUIT CURRENT mA (MIN.) (Note 1&2)	PICKUP VOLTAGE Vdc (MAX.) @ 25°C (Note 2)	BASE TURN ON CURRENT mA (MAX.) @ 25°C	PICKUP VOLTAGE Vdc (MAX.) @ 125°C (Note 2)	BASE TURN ON CURRENT mA (MAX.) @ 125°C	DROP-OUT VOLTAGE Vdc (MIN.) (Note 2)	DROP-OUT VOLTAGE Vdc (MIN.) @ -65°C (Note 2)	NOM. COIL POWER (mW) @ 25°C	MAX. COIL VOLTAGE	COIL DESIG.
MA/MAD												
5.0	50	n/a	n/a	2.7	n/a	3.5	n/a	0.22	0.14	500	5.8	5
6.0	98	n/a	n/a	3.5	n/a	4.5	n/a	0.28	0.18	367	8.0	6
9.0	220	n/a	n/a	5.3	n/a	6.8	n/a	0.54	0.35	368	12.0	9
12.0	390	n/a	n/a	7.0	n/a	9.0	n/a	0.63	0.41	369	16.0	12
18.0	880	n/a	n/a	10.5	n/a	13.5	n/a	0.91	0.59	368	24.0	18
26.5	1,560	n/a	n/a	14.2	n/a	18.0	n/a	1.37	0.89	450	32.0	26
30.0	2,500	n/a	n/a	17.7	n/a	22.0	n/a	1.50	1.00	360	36.0	30
MADD												
5.0	39	128.2	93.2	3.2	n/a	4.0	n/a	0.6	0.6	641	5.8	5
6.0	78	78.3	58.3	4.0	n/a	5.0	n/a	0.7	0.7	462	8.0	6
9.0	220	42.9	33.0	6.3	n/a	7.8	n/a	0.9	0.8	368	12.0	9
12.0	390	32.8	25.6	8.0	n/a	10.0	n/a	1.1	0.9	369	16.0	12
18.0	880	22.1	17.5	11.5	n/a	14.5	n/a	1.4	1.1	368	24.0	18
26.5	1,560	18.5	14.8	15.2	n/a	19.0	n/a	1.8	1.4	450	32.0	26
MAT												
5.0	50	112.1	82.2	2.7	0.75	3.5	3.00	0.22	0.14	500	5.8	5
6.0	98	69.9	52.9	3.5	0.55	4.5	2.04	0.28	0.18	367	8.0	6
9.0	220	47.4	35.3	5.3	0.36	6.8	1.36	0.54	0.35	368	12.0	9
12.0	390	35.8	26.6	7.0	0.27	9.0	1.03	0.63	0.41	369	16.0	12
18.0	880	24.0	17.9	10.5	0.16	13.5	0.68	0.91	0.59	368	24.0	18
26.5	1,560	19.8	14.7	14.2	0.13	18.0	0.50	1.37	0.89	450	32.0	26

Note 1: Coil resistance not directly measurable. Coil current should be within limits shown when tested at nominal voltage at 25°C for 5 seconds max.
Note 2: Set base current at 3 mA to 15 mA during measurements.

SPECIFYING A PART NUMBER EXAMPLE:	TYPE	TERMINALS	DIODES	GROUND PINS	COILS	SPREADER/MOUNTING PADS
	MA	C	D	G	-26	S



LR • LS

LR

**MAGNETIC LATCHING FOUR POLE
HALF SIZE HIGH-PERFORMANCE RELAY**

DESIGNED TO MIL-R-39016

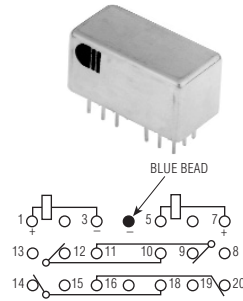

TERMINAL VIEW

STANDARD SCHEMATIC Contacts will switch from the indicated position when either coil is energized with polarity as shown.

FEATURES

- Hermetically sealed
- Up to 2 amps switching
- High shock & vibration ratings
- Optional terminals & mounting styles
- 4 form C hi-density latching design

LS

**MAGNETIC LATCHING HALF SIZE
HIGH-PERFORMANCE RELAY**

DESIGNED TO MIL-R-39016/45

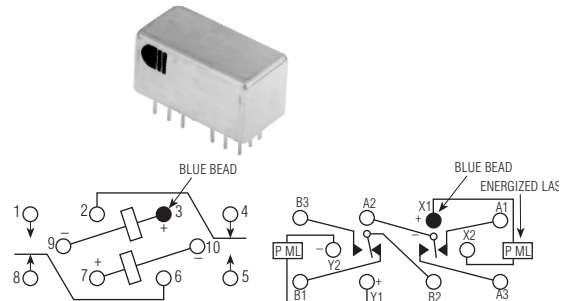

TERMINAL VIEW

STANDARD SCHEMATIC Contacts will switch from the indicated position when either coil is energized with polarity as shown.

FEATURES

- Hermetically sealed
- Up to 2 amps switching
- High shock & vibration ratings
- Optional terminals & mounting styles
- Latching design

MIL-R-39016/45 SCHEMATIC Contacts will switch from the indicated position when either coil is energized with polarity as shown.

ELECTRICAL CHARACTERISTICS

CONTACT ARRANGEMENT

LS: 2 Form C (DPDT)
LR: 4 Form C (4PDT)

CONTACT MATERIAL

Stationary:
Gold plated hardened silver alloy
Moveable:
Gold plated hardened silver alloy

CONTACT RESISTANCE

Before Life: 50 milliohms max.
(measured at 10 mA @ 6 Vdc)

After Life: 100 milliohms max.
(measured @ 2 A @ 28 Vdc)

MECHANICAL LIFE EXPECTANCY

1 million operations min.

COIL VOLTAGE

5 to 48 Vdc

COIL POWER

1.0 watts max.

DUTY CYCLE

Continuous

PICK-UP VOLTAGE

Approximately 50% of nominal coil voltage

PICK-UP SENSITIVITY

170 mW

CONTACT RATINGS

CONTACT LOAD	TYPE	OPERATIONS MIN.
2 A @ 28 Vdc	Resistive	100,000
0.3 A @ 115 Vac, 60 Hz & 400 Hz	Resistive	100,000
0.75 A @ 28 Vdc	Inductive (200mH)	100,000
0.1 A @ 28 Vdc	Intermediate	50,000
0.160 A @ 28 Vdc	Lamp	100,000
30 μ A @ 50 mVdc	Low Level	1,000,000

RF PERFORMANCE (LS ONLY)

FREQUENCY (MHz)	RF LOSSES (dB)	VSWR	ISOLATION (dB)
100	0.1	1.15:1	38
500	0.3	1.19:1	31
1000	0.6	1.32:1	45

LR-LS

OPERATING CHARACTERISTICS

TIMING

Set-Reset Time:
5.0 ms max.

CONTACT BOUNCE

2.0 ms max. (LS)
5.0 ms max. (LR)

DIELECTRIC WITHSTANDING VOLTAGE

Between Open Contacts:

500 Vrms 60 Hz (LS)
350 Vrms 60 Hz (LR)

Between Adjacent Contacts:

1000 Vrms 60 Hz (LS)
500 Vrms 60 Hz (LR)

Between Contacts and Coil:

1000 Vrms 60 Hz (LS)
500 Vrms 60 Hz (LR)

INSULATION RESISTANCE

10,000 megohms min. @ 500 Vdc

ENVIRONMENTAL CHARACTERISTICS

TEMPERATURE RANGE

-65°C to +125°C

WEIGHT

.46 oz (13 gms) max.

VIBRATION RESISTANCE

Standard: 20 G's, 10 to 2,000 Hz
QPL Equiv: 30 G's, 10 to 2,500 Hz

SHOCK RESISTANCE

100 G's, 6 ± 1 ms

QPL EQUIVALENT

MIL-R-39016/45 (LS)
MIL-R-39016 (LR)

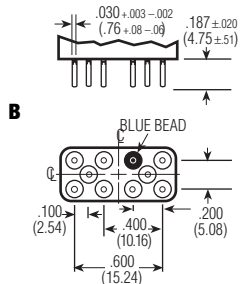
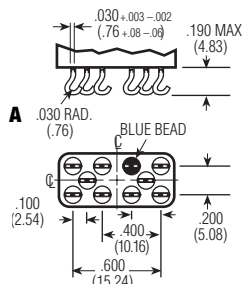

LS TERMINALS

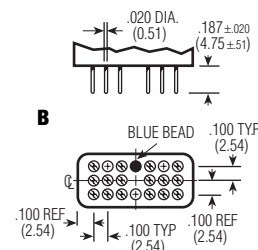
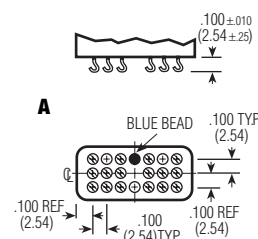

LR TERMINALS

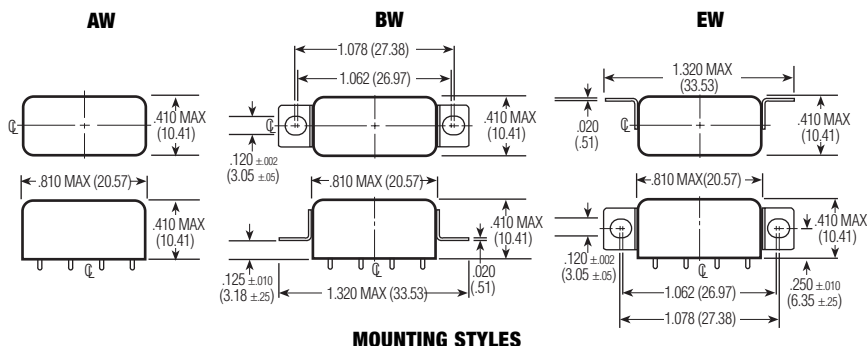

MOUNTING STYLES

STANDARD COIL DATA

NOM. COIL VOLTAGE (Vdc)	COIL RESISTANCE IN OHMS ±10% @ 25°C	PICKUP VOLTAGE Vdc (MAX.) @ 25°C	PICKUP VOLTAGE Vdc (MAX.) @ 125°C	PICKUP VOLTAGE Vdc (MIN.) @ 25°C	PICKUP VOLTAGE Vdc (MIN.) @ -65°C	NOM. COIL POWER (mW) @ 25°C	MAX. COIL VOLTAGE	COIL DESIG.
5.0	45	2.7	3.8	1.6	1.0	556	6.7	5
6.0	63	3.25	4.5	2.0	1.3	571	8.0	6
12.0	254	6.5	9.0	4.0	2.6	567	16.0	12
26.5	1,000	13.0	18.0	8.0	5.2	702	32.0	24
48.0	3,800	26.0	36.0	16.0	10.4	606	64.0	48

SPECIFYING A PART NUMBER EXAMPLE:

TYPE	MOUNTINGS	CONTACTS	COILS	TERMINALS
LR	BW-	4C-	24	B
LS	BW-	2C-	24	B





Product Facts

- Combines isolated load switching and circuit protection capabilities.
- Fast acting bounce-free switching
- Carries full rated load (2.5A) without heat sinking to 90°C.
- Low output on-resistance and voltage drop.
- Meets surge requirement of MIL-STD-1275 and MIL-STD-740A.
- Nuclear tolerance tested.



This controller features state of the art photo-voltaic optical input/output isolation and power MOSFET output switching technology for reliable control of DC loads up to 2.5 amps up to 90°C ambient. Temperature compensated output current monitoring and trip circuitry

provide overload/short circuit protection while providing inrush current handling capability for lamp, motor, and inductive loads. The output MOSFET chip is rated at 100V to withstand the abnormal power surge requirements of MIL-STD-1275 and MIL-STD-740A for

28Vdc systems. Thick film hybrid construction is employed in a low profile, hermetically sealed package that is designed and screened to applicable requirements of MIL-PRF-28750D, Y level.

Functional Block Diagram

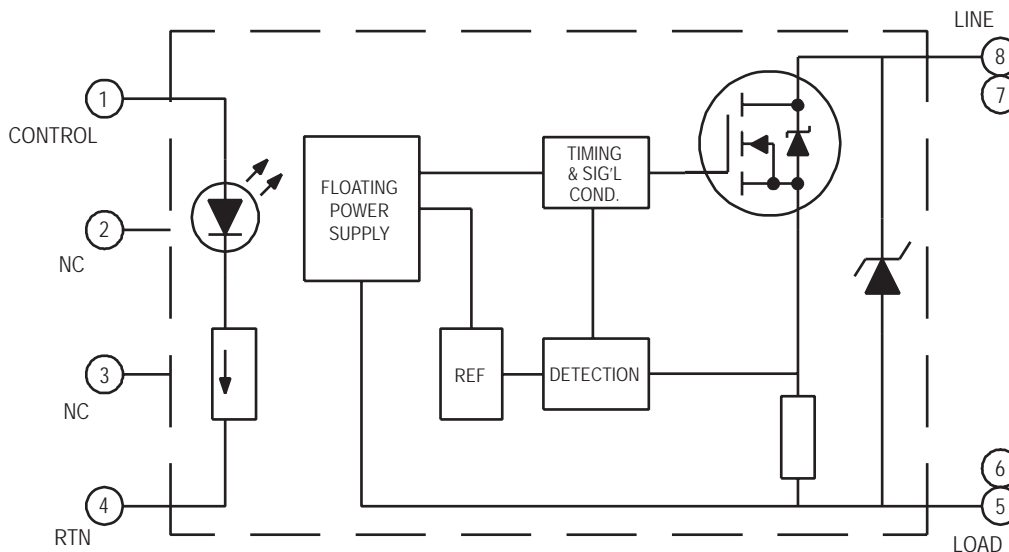

(see notes 4 and 5)

© 2005 by Tyco Electronics Corporation. All Rights Reserved.

CII and TYCO are trademarks. Other products and company names mentioned herein may be trademarks of their respective owners.



KSR-201 DC Solid State Relay / Power Controller (Continued)

Environmental Characteristics

Ambient Temperature Range:

Operating: -55°C to +105°C.
Storage: -55°C to +125°C.

Vibration Resistance:

20 G's, 10-2,000 Hz.

Shock Resistance:

1,500 G's, 0.5 ms pulse.

Constant Acceleration Resistance

(Y1 axis):

5,000 G's.

Mechanical Characteristics

Weight (max.):

.35 oz. (10 grams)

Materials:

Case: 1010 CRS, nickel plated
Pins: Copper cored Alloy 52, gold plated

Electrical Specifications (-55°C to +105°C unless otherwise specified)

Input

Control voltage range (Vcc)	3.8 - 32 Vdc (Notes 1 & 2, Figures 1 & 2)
Control current (max.) @ 5Vdc	15mA (Notes 1 & 2, Figures 1 & 2)
Must turn-on voltage	2.4Vdc
Must turn-off voltage	1.5Vdc
Reverse voltage protection	-7Vdc

I/O

Dielectric Strength (min.)	500V rms
Insulation Resistance (min.) @ 500Vdc	10 ⁸ ohms

Output

Continuous load current (max.)	2.5Adc (Figure 4)
Continuous load voltage (max.)	60Vdc
Transient blocking voltage (max.)	80Vdc (Note 2)
On resistance (max.) @ I _L = 100mA, 25°C	0.14 ohm
Output voltage drop (max.)	0.42Vdc
Leakage current (max.) @ V = 32Vdc	40µAdc
Turn-on time (max.)	1.8 ms (Note 3, Figure 5)
Turn-off time (max.)	1.1 ms (Figure 5)
Electrical system spike	600Vdc (Note 8)
Junction temperature (max.)	125°C
Thermal resistance (max.), junction to ambient	35°C/W
Thermal resistance (max.), junction to case	15°C/W
Inrush current, 75ms, no trip	10Adc (Figure 3)
Inrush current, 100ms, must trip	22Adc (Figure 3)
Inrush current, 200ms, no trip	4.5Adc (Figure 3)
Inrush current, 200ms, must trip	10Adc (Figure 3)



KSR-201 DC Solid State Relay / Power Controller (Continued)

Figure 1 - Input Current vs. Input Voltage

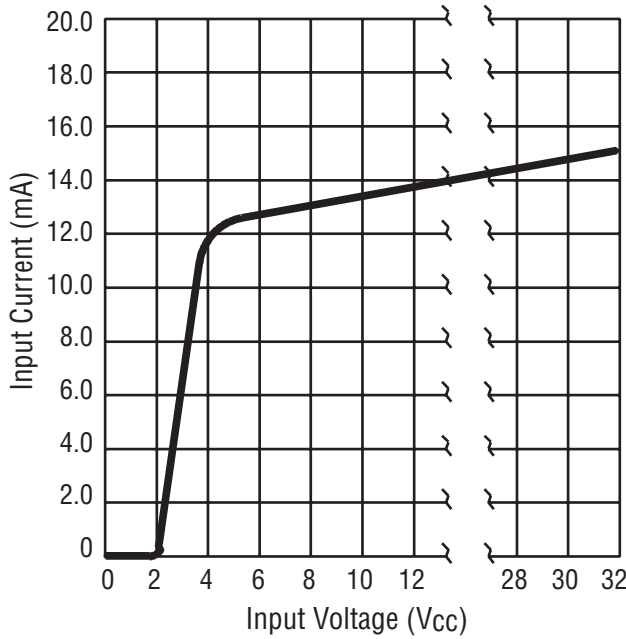

Figure 2 - Series Resistance vs. Vcc Input Voltage (Note 1)

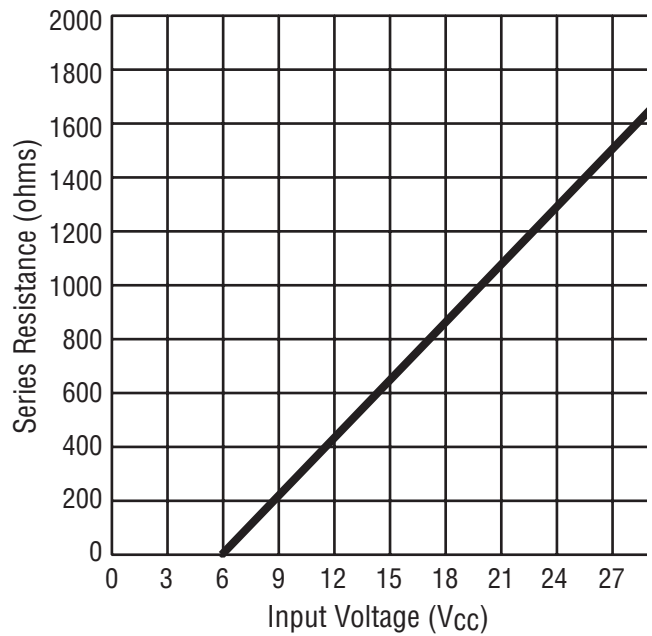

Figure 3 - Overload Trip Curve

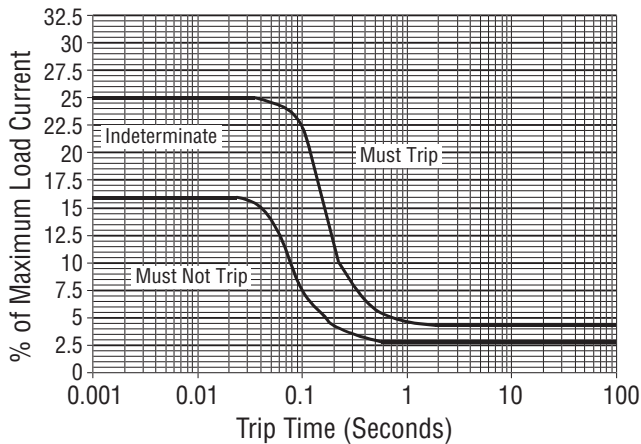
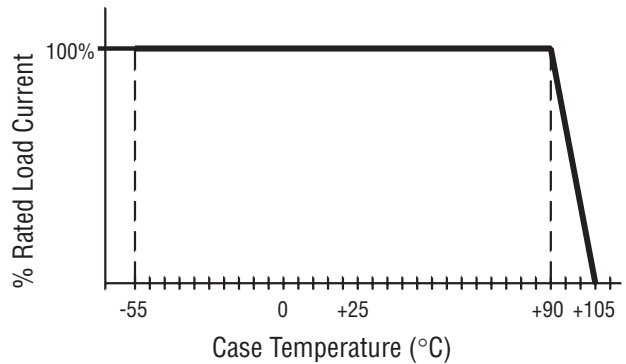

Figure 4 - Thermal Derating





KSR-201 DC Solid State Relay / Power Controller (Continued)

Figure 5 - Turn-On and Turn-Off Timing

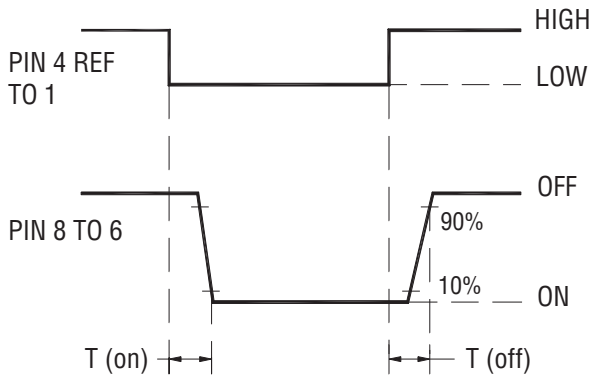
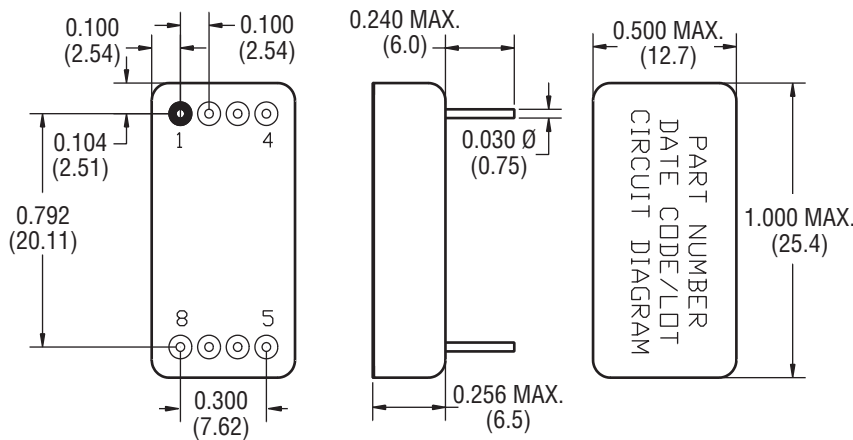

Figure 6 - Outline Dimensions



TOLERANCES:
± 0.010 (0.25mm) FOR 2 PLACE DECIMALS;
± 0.005 (0.13mm) FOR 3 PLACE DECIMALS;
UNLESS OTHERWISE NOTED.

Notes

- For control voltages >6.0 Vdc, a series resistor is recommended. See Fig. 2 for value. The control voltage is the voltage across the input terminals (pin 1 referenced to pin 4). Transition of the control voltage should be <1.0 msec and should be of a "bounce free" nature.
- Tested to the requirements of MIL-STD-1275. For transients >80 Vdc, the power controller will be protected and will pass the current resulting from the transient on to the load. The magnitude of the current is a function of the clamping voltage of the power controller and the source impedance of the transient. The clamping voltage of the power controller is 100 Vdc ±5% with a temperature coefficient of 0.1%/°C.
- Timing measurements taken with a resistive load, at $V_{BIAS} = 5.5$ Vdc and measured between the 10% and 90% points.
- The output of the Solid State Power Controller is floating, thereby allowing the load to be connected to the high or low side of the switch. The switch is capable of sinking or sourcing the load current. Reversing the polarity of the line voltage may cause permanent damage.
- Inductive loads must be diode suppressed. When switching into a shorted condition, series inductance must be <50 millihenries. Input repetition rate not to exceed 10 Hz when switching into a shorted condition.
- To reset power controller after a shorted or overload condition has occurred, remove the short circuit or overload condition; then remove and reapply the control voltage after a minimum 50 ms reset time.
- The rated input voltage for functional tests shall be 5.0 Vdc. This includes tests for on-resistance, output voltage drop, timing, short circuit and overload protection.
- Electrical system spike per MIL-PRF-28750, 10 ms

9-1773439-4-PDF-KRG-4-05
Printed in the U.S.A.



AC solid state relay for loads up to 25A @ 250Vrms

Product Facts

- Qualified to Mil-R-28750C (Mil p/n M28750/10-001Y and M28750/10-002Y).
- Optically coupled all solid state relay.
- TTL compatible input.
- Zero voltage turn-on for low EMI.
- Custom power package.

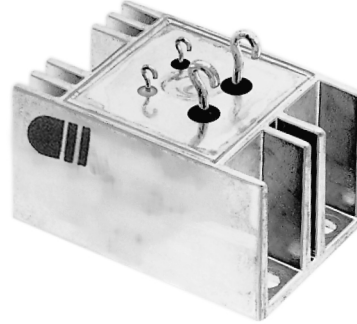

The JPS10 series solid state relay is designed for AC power switching up to 25 amps at 250Vrms. The circuit employs back-to-back photo SCRs with zero voltage turn-on for reliable switching of resistive or

reactive loads. TTL compatible input circuitry is optically isolated to 1,500Vrms from the AC load circuit. The relay is offered in two versions: the JPS10-1Y with a maximum zero voltage turn-on

window of 15 volts (preferred version for resistive loads), and the JPS10-2Y with a maximum window of 40 volts (preferred version for reactive loads).

CII Part Number	Military Part Number	Zero Crossing Window
JPS10-1Y	M28750/10-001Y	15 V pk max.
JPS10-2Y	M28750/10-002Y	40 V pk max.

Circuit Diagram

Terminal View

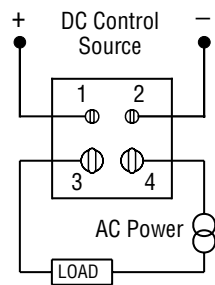

Outline Drawing

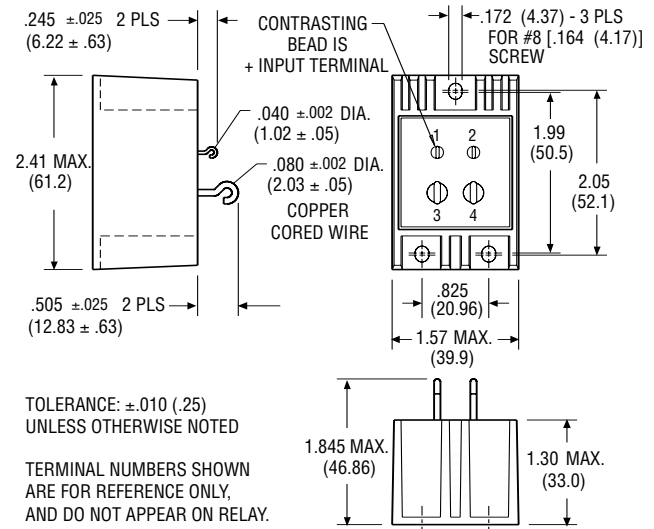



AC solid state relay for loads up to 25A @ 250Vrms (Continued)

Environmental Characteristics

Ambient Temperature Range:

Operating: -55°C to +110°C.
Storage: -55°C to +125°C.

Vibration Resistance:

30 G's, 10-3,000 Hz.

Shock Resistance:

1,500 G's, 0.5 ms pulse.

Constant Acceleration Resistance

(Y1 axis):

5,000 G's.

Mechanical Characteristics

Weight (max.):

6 oz. (170 grams)

Materials:

Case: Aluminum, hot tin dipped
Terminals: Copper cored wire, gold plated.

Electrical Specifications (-55°C to +105°C unless otherwise specified)

Input

Input supply voltage range (Vcc)	4 - 32 Vdc
Input current (max.)	16mAdc
Must turn-on voltage	4Vdc
Must turn-off voltage	1Vdc
Reverse voltage protection	-32Vdc

I/O

Dielectric strength (min.)	1,500Vrms/60 Hz.
Insulation resistance (min.) @ 500Vdc	10 ⁹ ohms
Capacitance (max.)	20pF

Output

Output current rating (max.)	25Arms (Fig. 2, Note 1)
Surge current (max.)	80A pk (Fig. 1, Note 2)
Continuous load voltage (max.)	250Vrms
Transient blocking voltage (max.)	500V pk
Frequency range	45 - 440 Hz.
Output voltage drop (max.) @ 25A load current	1.5Vrms
Off-state leakage current (max.) @ 220Vrms/400 Hz.	10mArms
Turn-on time (max.)	1/2 cycle
Turn-off time (max.)	1 cycle
Off-state dv/dt (min.), with snubber	200V /μs (Note 3)
Zero voltage turn-on window (max.), JPS10-1Y	15V pk
Zero voltage turn-on window (max.), JPS10-2Y	40V pk
Waveform distortion (max.)	4Vrms
Output chip junction temperature (max.)	125°C (Note 4)
Thermal resistance (max.), junction to ambient	6.8°C/W
Thermal resistance (max.), junction to case	1.2°C/W

Notes

1. Operation at elevated load currents up to 25 amps is dependent on the use of suitable heatsink to maintain case temperature per Fig. 2.
2. Heating of output chips during and after a surge may cause loss of output blocking capability until junction temperature falls below maximum rating.
3. Internal snubber network is provided across output chips.
4. Case temperature measurement point is center of mounting surface.

Figure 1 - Peak Surge Current vs. Surge Current Duration

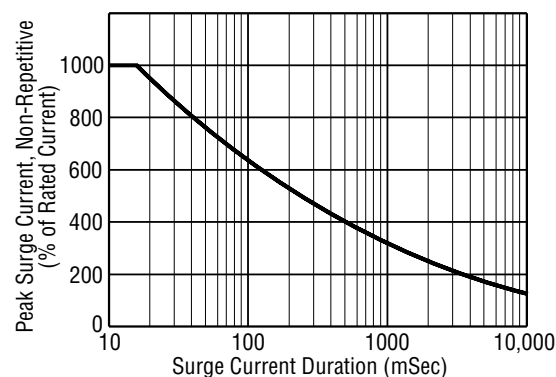
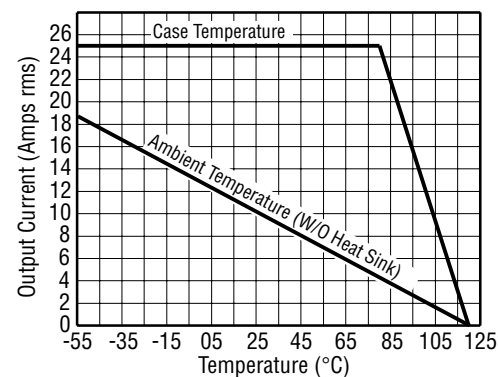

Figure 2 - Load Current vs. Temperature



HM · HMD · HS · HSD

HM · HS

**STANDARD • SENSITIVE TO-5
COMMERCIAL RELAY**

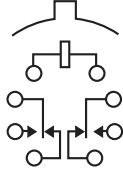

TERMINAL VIEW

FEATURES

- Hermetically sealed
- Spreader Pads
- Excellent RF switching

HMD · HSD

**STANDARD • SENSITIVE TO-5
DIODE SUPPRESSED
COMMERCIAL RELAY**

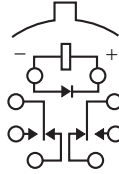

TERMINAL VIEW

FEATURES

- Suppression Diode
- Hermetically sealed
- Spreader Pads
- Excellent RF switching

ELECTRICAL CHARACTERISTICS

CONTACT ARRANGEMENT

2 Form C (DPDT)

CONTACT MATERIAL

Stationary:
Gold/platinum/palladium/silver alloy
(gold plated)

Moveable:
Gold/platinum/palladium/silver alloy
(gold plated)

CONTACT RESISTANCE

Before Life:
100 milliohms max.
(measured @ 10 mA @ 6 Vdc)

After Life:
200 milliohms max.
(measured @ 1 A @ 28 Vdc)

MECHANICAL LIFE EXPECTANCY

1 million operations

ELECTRICAL CHARACTERISTICS

COIL VOLTAGE

5 to 30 Vdc (HM/HMD)
5 to 48 Vdc (HS/HSD)

COIL POWER

HM/HMD:
675 mW max. @ 25°C

HS/HSD:
565 mW max. @ 25°C

DUTY CYCLE

Continuous

PICK-UP VOLTAGE

Approximately 70% of
nominal coil voltage

PICK-UP SENSITIVITY

HM/HMD:
180 mW max. @ 25°C

HS/HSD:
90 mW max. @ 25°C

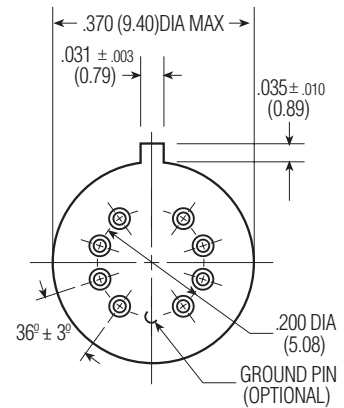

HEADER

CONTACT RATINGS

CONTACT LOAD	TYPE	OPERATIONS MIN.
1.0 A @ 28 Vdc	Resistive	100,000
250 mA @ 115 Vac, 60 Hz & 400 Hz	Resistive (Case not grounded)	100,000
100 mA @ 115 Vac, 60 Hz & 400 Hz	Resistive	100,000
0.2 A @ 28 Vdc	Inductive (0.32 Henry)	100,000
0.1 A @ 28 Vdc	Lamp	100,000
30 μA @ 50 mVdc	Low Level	1,000,000

TO-5 COMMERCIAL/INDUSTRIAL RELAYS



HM · HMD · HS · HSD

TO-5 COMMERCIAL/INDUSTRIAL RELAYS

OPERATING CHARACTERISTICS

TIMING

Operate Time:
HM/HMD: 4.0 ms max.
HS/HSD: 6.0 ms max.

Release Time:
HM: 3.0 ms max.
HS: 3.0 ms max.
HMD: 6.0 ms max.
(suppression diode)
HSD: 7.5 ms max.
(suppression diode)

DIELECTRIC WITHSTANDING VOLTAGE

Between Open Contacts:
350 Vrms 60 Hz
Between Adjacent Contacts:
350 Vrms 60 Hz
Between Contacts & Coil:
350 Vrms 60 Hz

INSULATION RESISTANCE

1,000 megohms @ 500 Vdc

ENVIRONMENTAL CHARACTERISTICS

TEMPERATURE RANGE

-55°C to +85°C

WEIGHT

HM/HMD:
0.09 oz. (2.55 gms)
0.099 oz. (2.80 gms) w/ spreader pad

HS/HSD:
0.12 oz. (3.40 gms)
0.129 oz. (3.45 gms) w/ spreader pad

VIBRATION RESISTANCE

10 G's, 10 to 500 Hz

SHOCK RESISTANCE

30 G's, 6 ± 1 ms

SEMICONDUCTOR CHARACTERISTICS

DIODE

100 Vdc peak inverse voltage (PIV)
1.0 Vdc max. transient voltage

STANDARD COIL DATA

	NOM. COIL VOLTAGE (Vdc)	COIL RESISTANCE IN OHMS ±20% @ 25°C	PICKUP VOLTAGE Vdc (MAX.) @ 25°C	NOM. COIL POWER (mW) @ 25°C	MAX. COIL VOLTAGE	COIL DESIG.
HM/HMD	5.0	50	3.6	500	5.8	5
	6.0	98	4.2	367	8.0	6
	9.0	220	6.5	368	12.0	9
	12.0	390	8.4	369	16.0	12
	18.0	880	13.0	368	24.0	18
	26.5	1,560	17.0	450	32.0	26
30.0	2,500	22.0	360	36.0	30	
HS/HSD	5.0	100	3.5	250	7.5	5
	6.0	200	4.5	180	10.0	6
	9.0	400	6.8	203	15.0	9
	12.0	850	9.0	169	20.0	12
	18.0	1,600	13.5	203	30.0	18
	26.5	3,300	18.0	213	40.0	26
	36.0	6,500	24.0	199	57.0	36
	48.0	11,000	32.0	209	75.0	48

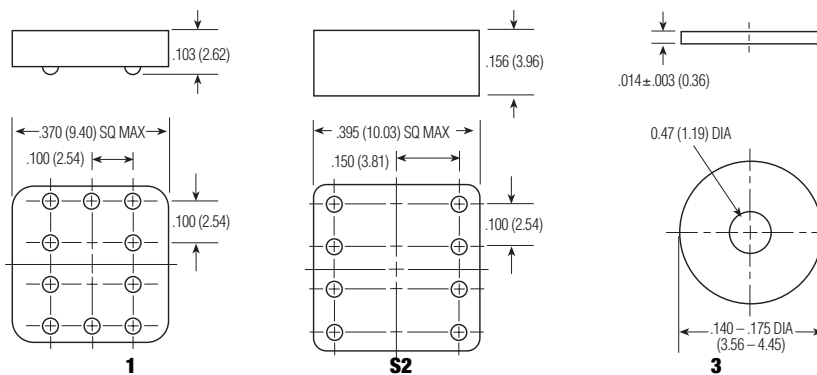
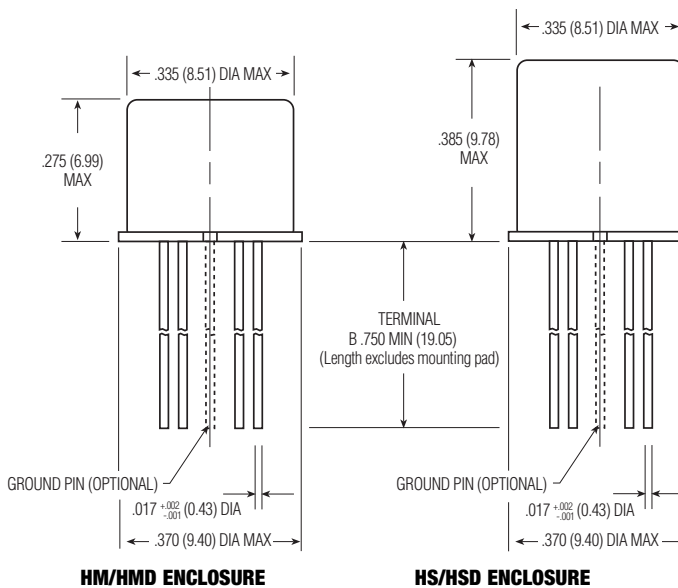

SPREADER AND MOUNTING PADS

SPECIFYING A PART NUMBER EXAMPLE:

TYPE HM DIODES D GROUND PIN X SPREADER/MOUNTING PADS 3 COILS -26 TERMINALS B



HFW · HFW4A · HFW5A · HMB · HMS

HALF SIZE HIGH PERFORMANCE RELAYS

HFW·HFW4A·HFW5A

**STANDARD HALF SIZE
HIGH-PERFORMANCE RELAY**

QUALIFIED TO MIL-R-39016/6

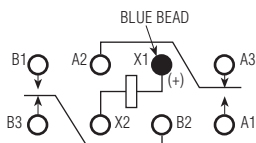
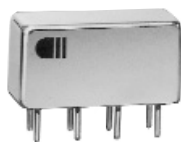

TERMINAL VIEW

FEATURES

- Hermetically sealed
- Up to 5 amps switching
- High shock & vibration ratings
- Optional terminals & mounting styles
- Excellent RF switching

HMB

**BIFILAR HALF SIZE
HIGH-PERFORMANCE RELAY**

QUALIFIED TO MIL-R-39016/22

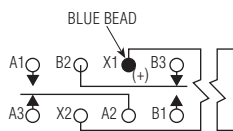
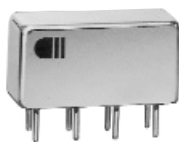

TERMINAL VIEW

FEATURES

- Hermetically sealed
- Up to 2 amps switching
- High shock & vibration ratings
- Optional terminals & mounting styles
- Excellent RF switching

HMS

**SENSITIVE HALF SIZE
HIGH-PERFORMANCE RELAY**

QUALIFIED TO MIL-R-39016/44

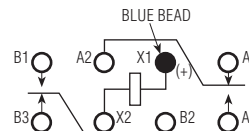

TERMINAL VIEW

FEATURES

- Hermetically sealed
- Up to 2 amps switching
- High shock & vibration ratings
- Optional terminals & mounting styles
- Excellent RF switching

ELECTRICAL CHARACTERISTICS

CONTACT ARRANGEMENT

2 Form C (DPDT)

CONTACT MATERIAL

Stationary:
Hardened silver alloy

Moveable:

Gold plated hardened silver alloy

CONTACT RESISTANCE

Before Life: 50 milliohms max.
(measured at 10 mA @ 6 Vdc)

After Life: 100 milliohms max.
(measured @ 2 A @ 28 Vdc)

MECHANICAL LIFE EXPECTANCY

50 million operations

COIL VOLTAGE

5 to 48 Vdc

COIL POWER

1.4 watts max. @ 25°C

DUTY CYCLE

Continuous

PICK-UP VOLTAGE

Approximately 50% of
nominal coil voltage

PICK-UP SENSITIVITY@25°C

145 to 260 mW (HFW)
325 mW (HMB)
100 to 125 mW (HMS)

CONTACT RATINGS

	CONTACT LOAD	TYPE	OPERATIONS MIN.
HFW,HMB,HMS	2 A @ 28 Vdc	Resistive	100,000
	HFW4A 4 A @ 28 Vdc	Resistive	100,000
HFW5A	5 A @ 28 Vdc	Resistive	100,000
	0.75 A @ 28 Vdc	Inductive (200mH)	100,000
	0.1 A @ 115 Vac, 60 Hz & 400 Hz	Resistive	100,000
	0.3 A @ 115 Vac, 60 Hz & 400 Hz	Resistive	100,000
	0.1 A @ 28 Vdc	Intermediate	50,000
	0.160 A @ 28 Vdc	Lamp	100,000
	30 µA @ 50 mVdc	Low Level	1,000,000

RF PERFORMANCE

FREQUENCY (MHz)	RF LOSSES (dB)	VSWR	ISOLATION (dB)
100	0.1	1.17:1	40
500	0.3	1.19:1	28
1000	0.4	1.19:1	23



HFW · HFW4A · HFW5A · HMB · HMS

OPERATING CHARACTERISTICS

TIMING

Operate Time: 4.0 ms max. (HFW)
 5.0 ms max. (HMB)
 6.0 ms max. (HMS)
 Release Time: 4.0 ms max. (HFW)
 5.0 ms max. (HMB/HMS)

CONTACT BOUNCE

2.0 ms max.

DIELECTRIC WITHSTANDING VOLTAGE

Between Open Contacts:
 500 Vrms 60 Hz

Between Adjacent Contacts:
 1000 Vrms 60 Hz

Between Contacts & Coil:
 1000 Vrms 60 Hz

INSULATION RESISTANCE

10,000 megohms min. @ 500 Vdc

ENVIRONMENTAL CHARACTERISTICS

TEMPERATURE RANGE

-65°C to +125°C

WEIGHT

0.46 oz. (13 gms max.)

VIBRATION RESISTANCE

HFW/HMB/HMS:
 Standard: 20 G's, 10 to 2,000 Hz

HFW/HMB:
 QPL: 30 G's, 10 to 3,000 Hz

HMS:
 QPL: 20 G's, 10 to 2,500 Hz

SHOCK RESISTANCE

100 G's, 6 ± 1 ms
 50 G's, 11 ± 1 ms (HMS)

QPL APPROVAL

MIL-R-39016/6 (HFW)

MIL-R-39016/22 (HMB)

MIL-R-39016/44 (HMS)

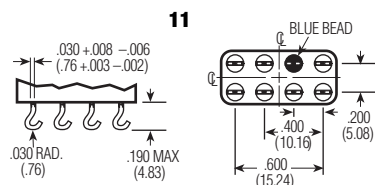

TERMINALS

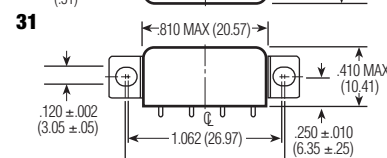
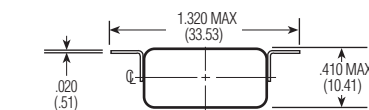
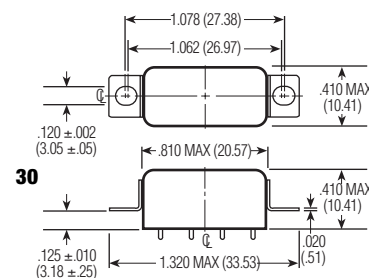
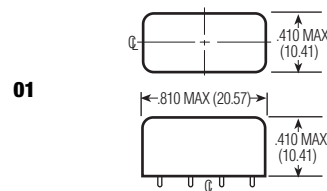
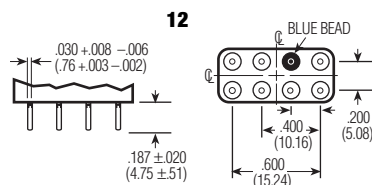

MOUNTING STYLES

STANDARD COIL DATA

	NOM. COIL VOLTAGE (Vdc)	COIL RESISTANCE IN OHMS ±10% @ 25°C	PICKUP VOLTAGE Vdc (MAX.) @ 25°C	PICKUP VOLTAGE Vdc (MIN.) @ 125°C	DROP-OUT VOLTAGE Vdc (MIN.) @ 25°C	DROP-OUT VOLTAGE Vdc (MIN.) @ -65°C	NOM. COIL POWER (mW) @ 25°C	MAX. COIL VOLTAGE	COIL DESIG.
HFW/HFW4A/HFW5A	5.0	27	2.7	3.8	0.29	0.21	926	6.0	L
	6.0	40	3.2	4.5	0.35	0.25	900	7.5	F
	12.0	160	6.4	9.0	0.7	0.5	900	15.0	G
	26.5	700	13.5	18.0	1.5	1.0	1003	32.0	K
HMB	6.0	40	3.6	4.8	0.35	0.25	900	7.5	F
	12.0	160	7.2	9.6	0.7	0.5	900	15.0	G
	26.5	700	15.0	20.0	1.5	1.0	1003	32.0	K
HMS	5.0	47	2.2	3.2	0.21	0.12	532	7.0	S001
	6.0	75	2.75	4.0	0.27	0.17	480	9.0	S002
	12.0	310	5.6	8.0	0.55	0.35	465	20.0	S003
	26.5	1,030	11.4	16.5	1.1	0.7	682	35.0	S004
	30.0	1,620	14.3	21.0	1.4	0.9	556	44.0	S005
	36.0	2,640	18.0	26.0	1.8	1.1	491	56.0	S006
OTHER	6-8	60	3.5	4.85	0.35	0.22	817	9.0	A
	(avail. for 12-15	320	6.8	9.42	0.68	0.44	570	21.0	B
HFW/HFW4A relays only)	18.0	520	9.5	13.16	0.95	0.62	623	27.0	J
	26.5-32	1,250	14.0	19.4	1.5	0.98	684	42.0	D
	40.0	2,700	21.3	29.5	2.1	1.37	593	61.0	H
	48.0	3,500	25.5	35.3	2.5	1.63	658	70.0	E

SPECIFYING A PART NUMBER EXAMPLE:

TYPE HFW TERMINALS 12 MOUNTINGS 30 COILS K FEATURES 00 (n/a HMS)



HFC

HFC

COMMERCIAL/INDUSTRIAL
HALF SIZE RELAY

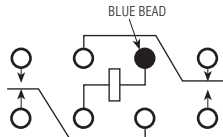
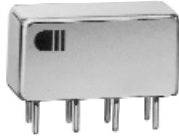

TERMINAL VIEW

FEATURES

- Hermetically sealed
- Up to 5 amps switching
- Economical configuration
- Optional terminals & mounting styles

01

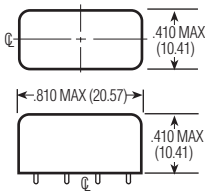

30

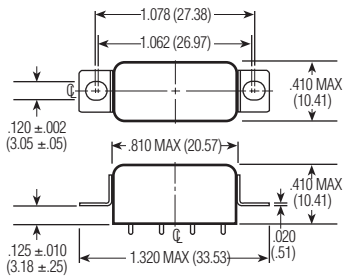

31

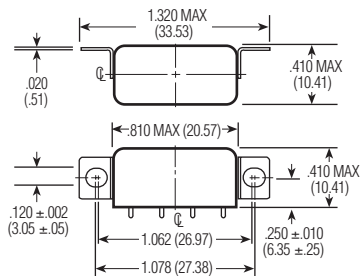

MOUNTING STYLES

ELECTRICAL CHARACTERISTICS

CONTACT ARRANGEMENT

2 Form C (DPDT)

CONTACT MATERIAL

Stationary:
Bifurcated hardened silver alloy

Moveable:
Gold plated hardened alloy

CONTACT RESISTANCE

Before Life: 50 milliohms max.
(measured at 10 mA @ 6 Vdc)

After Life: 100 milliohms max.
(measured @ 2 A @ 28 Vdc)

MECHANICAL LIFE EXPECTANCY

10 million operations

COIL VOLTAGE

5 to 26.5 Vdc

COIL POWER

1.4 watts max. @ 25°C

DUTY CYCLE

Continuous

PICK-UP VOLTAGE

Approximately 60% of
nominal coil voltage

PICK-UP SENSITIVITY

360 mW

OPERATING CHARACTERISTICS

TIMING

Operate Time:
6.0 ms max.

Release Time:
6.0 ms max.

DIELECTRIC WITHSTANDING VOLTAGE

Between Open Contacts:
350 Vrms 60 Hz

Between Adjacent Contacts:
500 Vrms 60 Hz

Between Contacts and Coil:
500 Vrms 60 Hz

INSULATION RESISTANCE

1,000 megohms min @ 500 Vdc

ENVIRONMENTAL CHARACTERISTICS

TEMPERATURE RANGE

-55°C to +85°C

WEIGHT

0.46 oz. (13 gms) max.

VIBRATION RESISTANCE

10 G's, 10 to 500 Hz

SHOCK RESISTANCE

30 G's, 6 ± 1 ms

CONTACT RATINGS

CONTACT LOAD	TYPE	OPERATIONS MIN.
2 A @ 28 Vdc	Resistive	100,000
HFC4A 4 A @ 28 Vdc	Resistive	100,000
HFC5A 5 A @ 28 Vdc	Resistive	100,000
0.75 A @ 28 Vdc	Inductive (200 mH)	100,000
0.3 A @ 115 Vac, 60 Hz & 400 Hz	Resistive	100,000

STANDARD COIL DATA

NOM. COIL VOLTAGE (Vdc)	COIL RESISTANCE IN OHMS ± 20% @ 25°C	PICKUP VOLTAGE Vdc (MAX.) @ 25°C	PICKUP VOLTAGE Vdc (MAX.) @ 85°C	NOM. COIL POWER (W) @ 25°C	MAX. COIL VOLTAGE	COIL DESIG.
5.0	27	3.0	3.7	.92	6.0	L
6.0	40	3.6	4.5	.90	7.5	F
12.0	160	7.2	8.9	.90	15.0	G
26.5	700	16.0	19.7	1.00	32.0	K

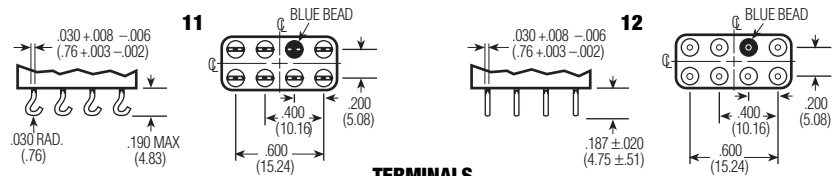

TERMINALS

SPECIFYING A PART NUMBER EXAMPLE:

TYPE HFC **TERMINALS** 12 **MOUNTINGS** 30 **COILS** K **FEATURES** 00

HC · HCD · HCS · HCSD

HC · HCS

STANDARD • SENSITIVE
.100 GRID COMMERCIAL RELAY

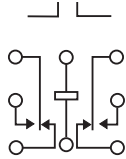

TERMINAL VIEW

FEATURES

- Hermetically sealed
- Mounting Pads
- Excellent RF switching

HCD · HCSD

STANDARD • SENSITIVE
.100 GRID DIODE SUPPRESSED
COMMERCIAL RELAY

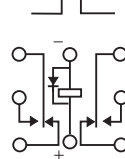

TERMINAL VIEW

FEATURES

- Suppression Diode
- Hermetically sealed
- Mounting Pads
- Excellent RF switching

ELECTRICAL CHARACTERISTICS

CONTACT ARRANGEMENT

2 Form C (DPDT)

CONTACT MATERIAL

Stationary:
Gold/platinum/palladium/silver alloy
(gold plated)

Moveable:
Gold/platinum/palladium/silver alloy
(gold plated)

CONTACT RESISTANCE

Before Life:
100 milliohms max.
(measured @ 10 mA @ 6 Vdc)

After Life:
200 milliohms max.
(measured @ 1 A @ 28 Vdc)

MECHANICAL LIFE EXPECTANCY

1 million operations

ELECTRICAL CHARACTERISTICS

COIL VOLTAGE

5 to 26.5 Vdc (HC/HCD)
5 to 48 Vdc (HCS/HCSD)

COIL POWER

HC/HCD:
660 mW max. @ 25°C

HCS/HCSD:
565 mW max. @ 25°C

DUTY CYCLE

Continuous

PICK-UP VOLTAGE

Approximately 70% of
nominal coil voltage

PICK-UP SENSITIVITY

HC/HCD:
180 mW max. @ 25°C

HCS/HCSD:
90 mW max. @ 25°C

OPERATING CHARACTERISTICS

CONTACT RATINGS

CONTACT LOAD	TYPE	OPERATIONS MIN.
1.0 A @ 28 Vdc	Resistive	100,000
250 mA @ 115 Vac, 60 Hz & 400 Hz	Resistive (Case not grounded)	100,000
100 mA @ 115 Vac, 60 Hz & 400 Hz	Resistive	100,000
0.2 A @ 28 Vdc	Inductive (0.32 Henry)	100,000
0.1 A @ 28 Vdc	Lamp	100,000
30 µA @ 50 mVdc	Low Level	1,000,000

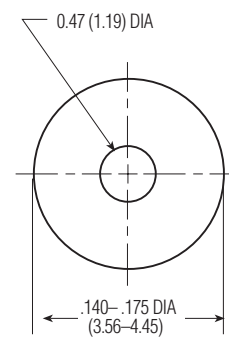
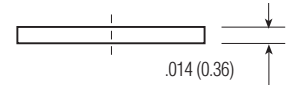

MOUNTING PAD

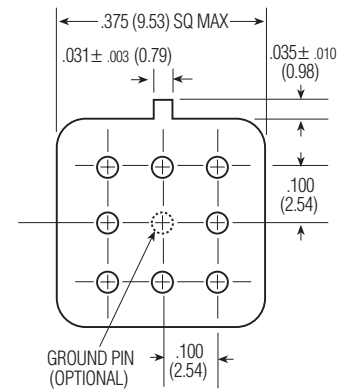

HEADER

HC · HCD · HCS · HCSD

100 GRID HIGH-PERFORMANCE RELAYS

TIMING

Operate Time:
HC/HCD: 4.0 ms max.
HCS/HCSD: 6.0 ms max.

Release Time:
HC: 3.0 ms max.
HCS: 3.0 ms max.
HCD: 6.0 ms max.
(suppression diode)
HCSD: 7.5 ms max.
(suppression diode)

DIELECTRIC WITHSTANDING VOLTAGE

Between Open Contacts:
350 Vrms 60 Hz

Between Adjacent Contacts:
350 Vrms 60 Hz

Between Contacts & Coil:
350 Vrms 60 Hz

INSULATION RESISTANCE

1,000 megohms @ 500 Vdc

ENVIRONMENTAL CHARACTERISTICS

TEMPERATURE RANGE

-55°C to + 85°C

WEIGHT

HC/HCD:
0.09 oz. (2.55 gms)

HCS/HCSD:
0.15 oz. (4.30 gms)

VIBRATION RESISTANCE

10 G's, 10 to 500 Hz

SHOCK RESISTANCE

30 G's, 6 ± 1 ms

SEMICONDUCTOR CHARACTERISTICS

DIODE

100 Vdc peak inverse voltage (PIV)
1.0 Vdc max. transient voltage

STANDARD COIL DATA

	NOM. COIL VOLTAGE (Vdc)	COIL RESISTANCE IN OHMS ±20% @ 25°C	PICKUP VOLTAGE Vdc (MAX.) @ 25°C	NOM. COIL POWER (mW) @ 25°C	MAX. COIL VOLTAGE	COIL DESIG.
HC/HCD	5.0	64	3.8	391	5.8	5
	6.0	98	4.9	367	8.0	6
	9.0	220	7.0	368	12.0	9
	12.0	400	9.0	360	16.0	12
	18.0	880	14.0	368	24.0	18
	26.5	1,600	18.0	439	32.0	26
HCS/HCSD	5.0	100	3.5	250	7.5	5
	6.0	200	4.5	180	10.0	6
	9.0	400	6.8	203	15.0	9
	12.0	800	9.0	180	20.0	12
	18.0	1,600	13.5	203	30.0	18
	26.5	3,200	18.0	219	40.0	26
	36.0	6,500	24.0	199	57.0	36
	48.0	11,000	32.0	209	75.0	48

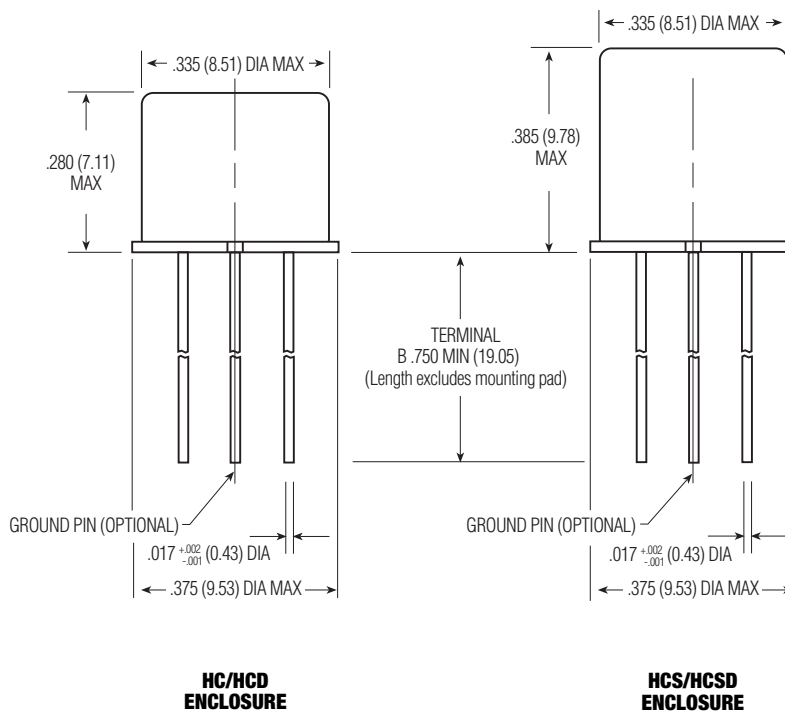

SPECIFYING A PART NUMBER EXAMPLE:

TYPE HC DIODES D GROUND PIN X MOUNTING PADS 3 COILS -26 TERMINALS B



FW · FW5A · SF · SF5A

FULL SIZE HIGH PERFORMANCE RELAYS

FW · FW5A · SF · SF5A

**TWO POLE FULL SIZE
CRYSTAL CAN RELAY**

FW QUALIFIED TO MIL-R-5757/10

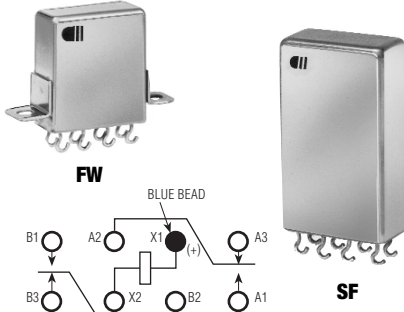

FEATURES

- Hermetically sealed
- Up to 5 amps switching
- High shock & vibration ratings
- Optional terminals & mounting options
- Excellent RF switching

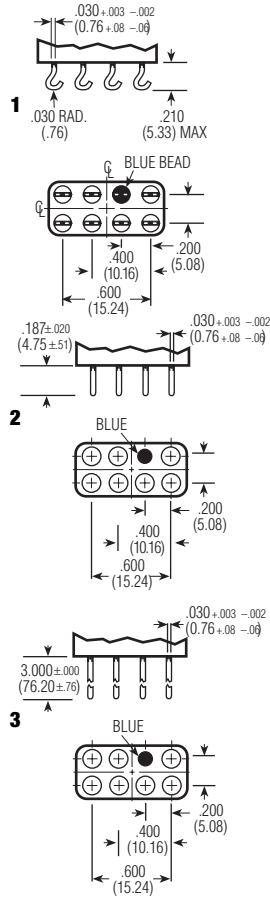

TERMINALS

ELECTRICAL CHARACTERISTICS

CONTACT ARRANGEMENT

2 Form C

CONTACT MATERIAL

Stationary:
Bifurcated hardened silver alloy

Moveable:

Gold plated hardened silver alloy

CONTACT RESISTANCE

Before Life: 50 milliohms max.
(measured @ 10 mA @ 6 Vdc)

After Life: 100 Milliohms max.
(measured @ 2 mA @ 28 Vdc)

MECHANICAL LIFE EXPECTANCY

50 million operations

COIL VOLTAGE

1.8 Vdc to 110 Vdc

COIL POWER

1.5 watts max. @ 25° C

DUTY CYCLE

Continuous

PICK-UP VOLTAGE

Approximately 50% of
nominal coil voltage

PICK-UP SENSITIVITY

250 mW (FW)
40 mW (SF)
80 mW (SF 5A)

RF PERFORMANCE (FW ONLY)

FREQUENCY (MHz)	RFLOSSES (dB)	VSWR	ISOLATION (dB)
100	0.1	1.17:1	40
250	0.2	1.18:1	33
500	0.3	1.19:1	28
750	0.4	1.19:1	25
1,000	0.4	1.19:1	23

OPERATING CHARACTERISTICS

TIMING

Operate Time:
15 ms max. (SF)
5 ms (FW)
6 ms max. (MIL-R-5757/10)

Release Time:
10 ms max. (SF)
5 ms max. (FW)
6 ms max. (MIL-R-5757/10)

Contact Bounce:
2 ms max.

DIELECTRIC WITHSTANDING VOLTAGE

Between Open Contacts:
500 Vrms, 60 Hz

Between Adjacent Contacts:
1,000 Vrms, 60 Hz

Between Contacts and Coil:
1,000 Vrms, 60 Hz

INSULATION RESISTANCE

10,000 Megohms @ 500 Vdc

ENVIRONMENTAL CHARACTERISTICS

TEMPERATURE RANGE

-65° to +125°C

WEIGHT

0.6 oz. max. (FW)
0.7 oz. max. (SF 6)
1.1 oz. max. (SF/SF 5A)

STANDARD VIBRATION RESISTANCE

20 G's, 10 to 2000 Hz (FW)
15 G's, 10 to 2000 Hz (SF)
QPL: 20 G's, 10 to 2000 Hz

SHOCK RESISTANCE

100 G's, 6 ± 1 ms

QPL APPROVAL

MIL-R-5757/10 (FW only)

QPL EQUIVALENT

MIL-R-5757/13 (SFonly)

CONTACT RATINGS

CONTACT LOAD	TYPE	OPERATIONS MIN.
5 A @ 28 Vdc (FW5A/SF5A)	Resistive	100,000
3 A @ 28 Vdc (FW)	Resistive	100,000
2 A @ 28 Vdc (SF)	Resistive	100,000
1 A @ 115 Vac, 60 Hz & 400 Hz (FW)	Resistive	100,000
0.3 A @ 115 Vac, 60 Hz & 400 Hz (SF)	Resistive	100,000
1 A @ 28 Vdc	Inductive (200 mH)	100,000
0.1 A @ 28 Vdc	Lamp	100,000
10 uA @ 50 mVdc	Low Level	1,000,000
75 WATTS @ 50 MHz (FW)	RF	10,000,000

FW • FW5A • SF • SF5A

FULL SIZE HIGH PERFORMANCE RELAYS

FW COIL DATA

NOM. COIL VOLTAGE (Vdc)	COIL RESISTANCE IN OHMS ±10% @ 25°C	PICKUP VOLTAGE Vdc (MAX.) @ 25°C	PICKUP VOLTAGE Vdc (MAX.) @ 125°C	DROPOUT VOLTAGE Vdc (MIN.) @ 25°C	DROPOUT VOLTAGE Vdc (MIN.) @ -65°C	NOM. COIL POWER (W) @ 25°C	MAX. COIL VOLTAGE	COIL DESIG.
6.3	35	3.2	4.4	0.35	0.23	1.13	7.9	A
12.6	200	6.8	9.4	0.74	0.49	.79	15.8	D
17.6	340	8.9	12.3	0.97	0.64	.91	22.0	E
26.5	675	13.5	18.7	1.47	0.96	1.04	33.1	G
32.0	975	15.5	21.5	1.69	1.1	1.05	40.0	H
48.0	2,450	25.0	34.7	2.73	1.8	.94	60.0	L
56.0	3,150	30.0	41.6	3.27	2.1	1.90	70.0	M
75.0	5,000	38.0	52.7	4.14	2.7	1.13	93.8	N
110.0	9,100	51.0	70.7	5.56	3.6	1.33	137.5	R

SF5 /SF6 COIL DATA

NOM. COIL VOLTAGE (Vdc)	NOM. CURRENT (mA)	COIL RESISTANCE IN OHMS ±10% @ 25°C	PICKUP CURRENT (mA) @ 25°C	NOM. COIL POWER (mW) @ 25°C	COIL DESIG.
1.8	90.0	20	45.0	162	A
9.0	18.0	500	9.0	162	E
12.6	12.6	1,000	6.5	159	F
16.5	11.0	1,500	5.2	182	G
18.0	9.0	2,000	4.5	162	H
20.0	8.0	2,500	4.0	160	J
26.5	5.3	5,000	2.8	140	W
36.0	4.5	8,000	2.3	162	L
40.0	4.0	10,000	2.0	160	Y

SF5A COIL DATA

NOM. COIL VOLTAGE (Vdc)	NOM. CURRENT (mA)	COIL RESISTANCE IN OHMS ±10% @ 25°C	PICKUP CURRENT (mA) @ 25°C	NOM. COIL POWER (mW) @ 25°C	COIL DESIG.
2.8	140.0	20	65.0	392	A
4.0	80.0	50	41.6	320	B
12.0	24.0	500	12.5	288	E
18.0	18.0	1,000	9.3	324	F
26.5	10.6	2,500	5.6	281	J
40.0	8.0	5,000	4.0	320	W

NOTE:
FW/FW5A = .875 (22.23) MAX
SF6 = .900 (22.86) MAX
SF5/SF5A5 = 1.281 (32.54) MAX

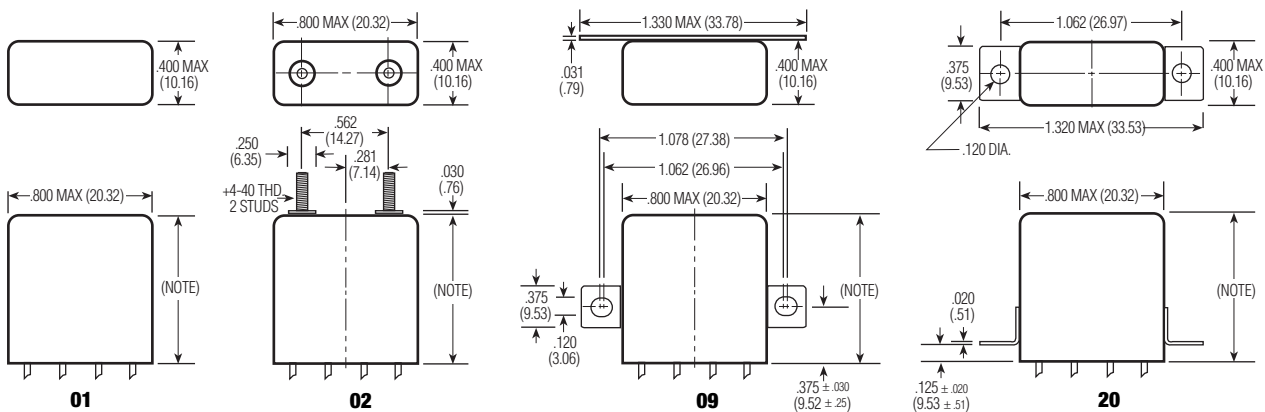

MOUNTING STYLES

SPECIFYING A PART NUMBER EXAMPLE:

TYPE	SERIES	TERMINALS	MOUNTINGS	COILS	FEATURES
FW	1	1	20	G	00
SF	5	1	20	W	00
SF5A	5	1	20	W	00
SF	6	1	20	W	00





DC solid state relay for loads up to 2A @ 60Vdc

Product Facts

- **Standard options: short circuit/overload protection and control status.**
- **Optically coupled all solid state relay.**
- **TTL & CMOS compatible input.**
- **Low on-resistance power MOSFET output.**
- **Tested per MIL-R-28750 and approved to DSCC drawing 90091.**
- **All versions available with Tyco Electronics "W" level screening for CII relays.**

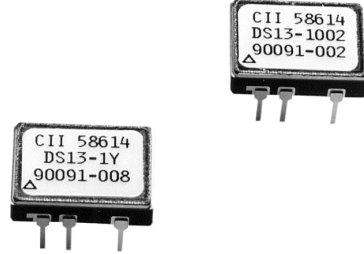

DS13 series SSRs employ state of the art photo-voltaic optical isolation and power MOSFET output chips for ultra-reliable high speed switching of DC loads up to 2 amps, with low on-resistance. Standard options include integral current overload/short circuit

protection and a separate input control status line. The overload feature provides protection of the relay, load and load circuit wiring in the event of a sustained current overload or short circuit while the relay is on or when it is turned on into a short. The control

status provides a built-in test function which provides a logic "0" when the input circuit is energized and functional. The relay is packaged into a custom hermetically sealed low-profile 8-pin ceramic DIP package, with through hole or surface mount pins.

CII Part No.	DSCC Dwg. No.	Relay Version
DS13-1Y	90091-008	Basic relay
DS13-1000	90091-004	Relay w/ short circuit protection
DS13-1001	90091-006	Relay w/ control status
DS13-1002	90091-002	Relay w/ short circuit protection and control status

Note: Add suffix "S" to part number for surface mount versions.

2 Terminal Input Configuration

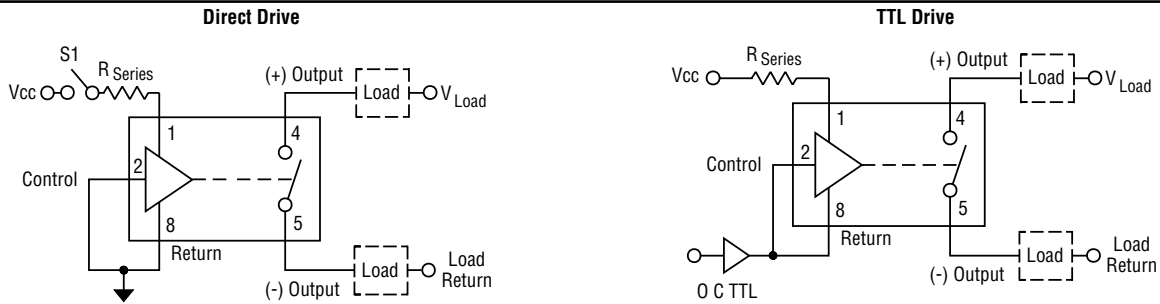

3 Terminal Input Configuration

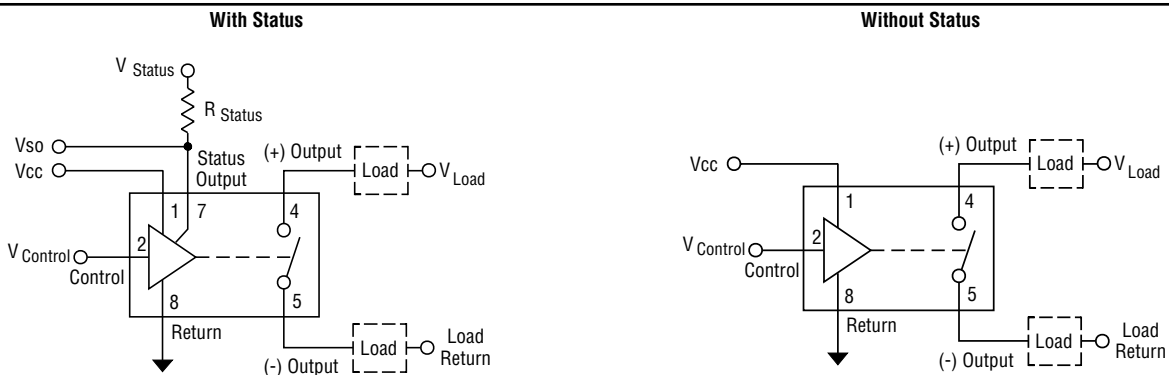

© 2004 by Tyco Electronics Corporation. All Rights Reserved. CII and TYCO are trademarks.



DC solid state relay for loads up to 2A @ 60Vdc (Continued)

Environmental Characteristics

Ambient Temperature Range:

Operating: -55°C to +105°C.
Storage: -55°C to +125°C.

Vibration Resistance:

100 G's, 10-3,000 Hz.

Shock Resistance:

1,500 G's, 0.5 ms pulse.

Constant Acceleration Resistance:

5,000 G's.

Mechanical Characteristics

Weight (max.):

.07 oz. (2 grams)

Materials:

Case: DIP, hermetically sealed,
ceramic

Pins: Gold plated

Electrical Specifications (-55°C to +105°C unless otherwise specified)

Input (2 terminal configuration)

Input supply voltage range (Vcc)	3.8 - 32 Vdc (Notes 1 & 2, Figures 1 & 2)
Input current (max.) @ 5Vdc	15mAdc (Notes 1 & 2, Figures 1 & 2)
Must turn-on voltage	3.8Vdc
Must turn-off voltage	1.5Vdc
Reverse voltage protection	-32Vdc

Input (3 terminal configuration)

Control voltage range	0 - 18 Vdc
Control current (max.)	240µAdc @ 5V, 1mA @ 18V
Input supply voltage range (Vcc)	3.8 - 32 Vdc (Notes 1 & 2, Figures 1 & 2)
Input current (max.) @ 5Vdc	15mAdc (Notes 1 & 2, Figures 1 & 2)
Must turn-on voltage	0.3Vdc
Must turn-off voltage	3.2Vdc

I/O

Dielectric Strength (min.)	1,000V rms
Insulation Resistance (min.) @ 500Vdc	10 ⁹ ohms
Capacitance (max.)	10pF

Output

Continuous load current (max.) @ 25°C, without short circuit protection	2.0Adc (Figure 5, Note 3)
Continuous load current (max.) @ 25°C, with short circuit protection	1.0Adc (Figure 5, Note 3)
Continuous load voltage (max.)	60Vdc
Transient blocking voltage (max.)	80Vdc (Note 4)
On resistance (max.) @ T _j = 25°C, I _L = 100ma, with short circuit protection	0.45 ohm (Note 5, Figure 4)
On resistance (max.) @ T _j = 25°C, I _L = 100ma, without short circuit protection	0.22 ohm (Note 5, Figure 4)
Output voltage drop (max.), with short circuit protection	0.6Vdc
Output voltage drop (max.), without short circuit protection	0.75Vdc
Off-state leakage current (max.) @ 60Vdc	100µAdc
Turn-on time (max.)	1.5 ms (Figure 3)
Turn-off time (max.)	.25 ms (Figure 3)
dv/dt (min.)	100V / µs
Electrical system spike	±600Vdc (Note 4)
Junction temperature (max.)	150°C
Thermal resistance (max.), junction to ambient	80°C/W
Thermal resistance (max.), junction to case	20°C/W

Status

Status supply voltage	30Vdc
Status sink current (max.) @ Vstatus ≤ 0.3Vdc	2mAdc (Note 7)
Status leakage current (max.) @ 15Vdc	4µAdc

Short Circuit Protection

See Figure 6, Note 7



Figure 1 - Maximum Input Current vs. Input Voltage

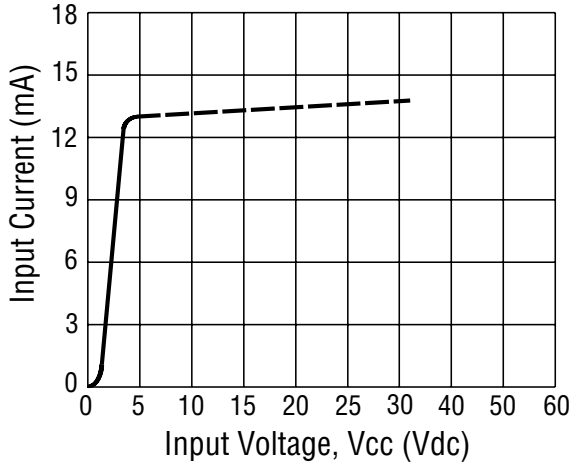

Figure 2 - Series Resistance vs. Vcc Supply Voltage (Note 1)

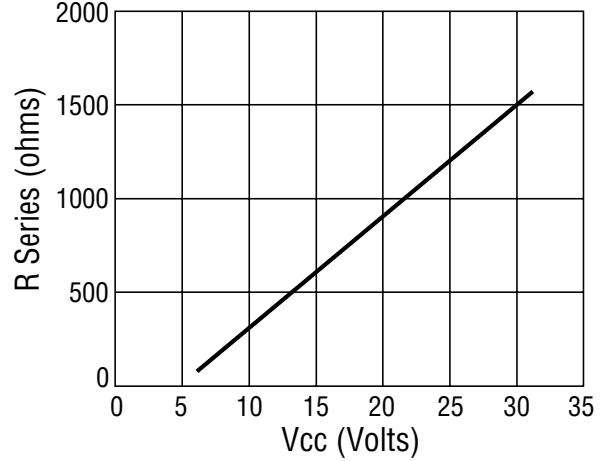

Figure 3 - Output Turn-on and Turn-off Timing

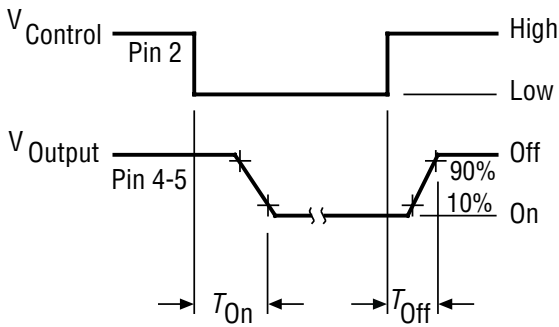

Figure 4 - On-Resistance vs. Temperature (Note 6)

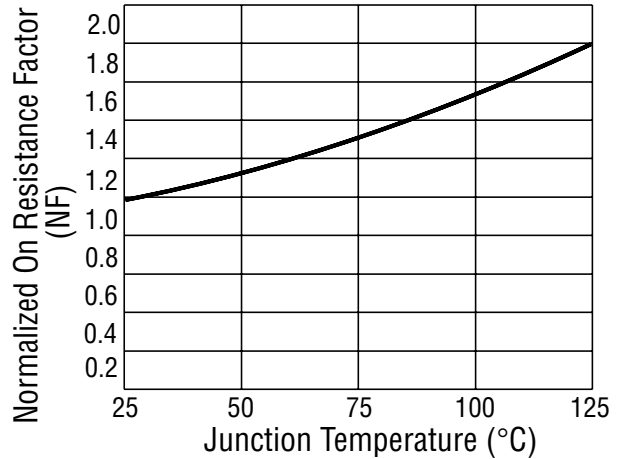

Figure 5 - Temperature Derating Curve

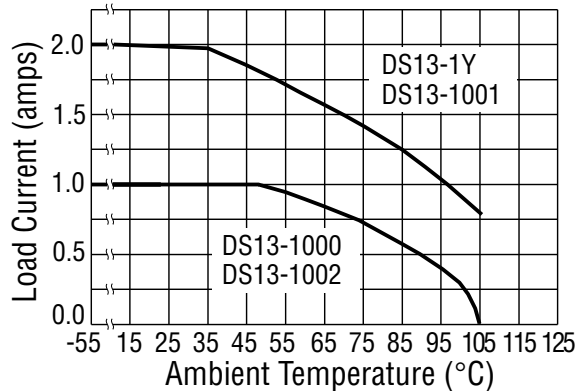

Figure 6 - Typical Current Trip Levels

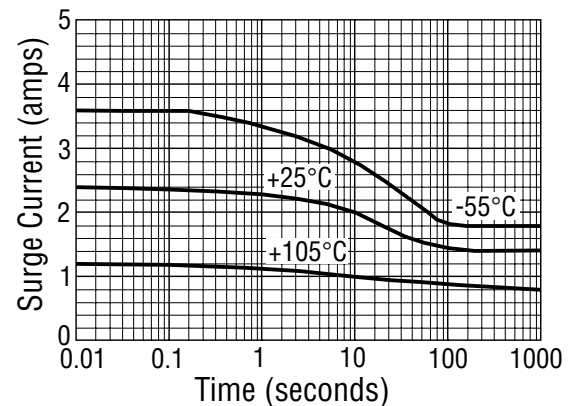
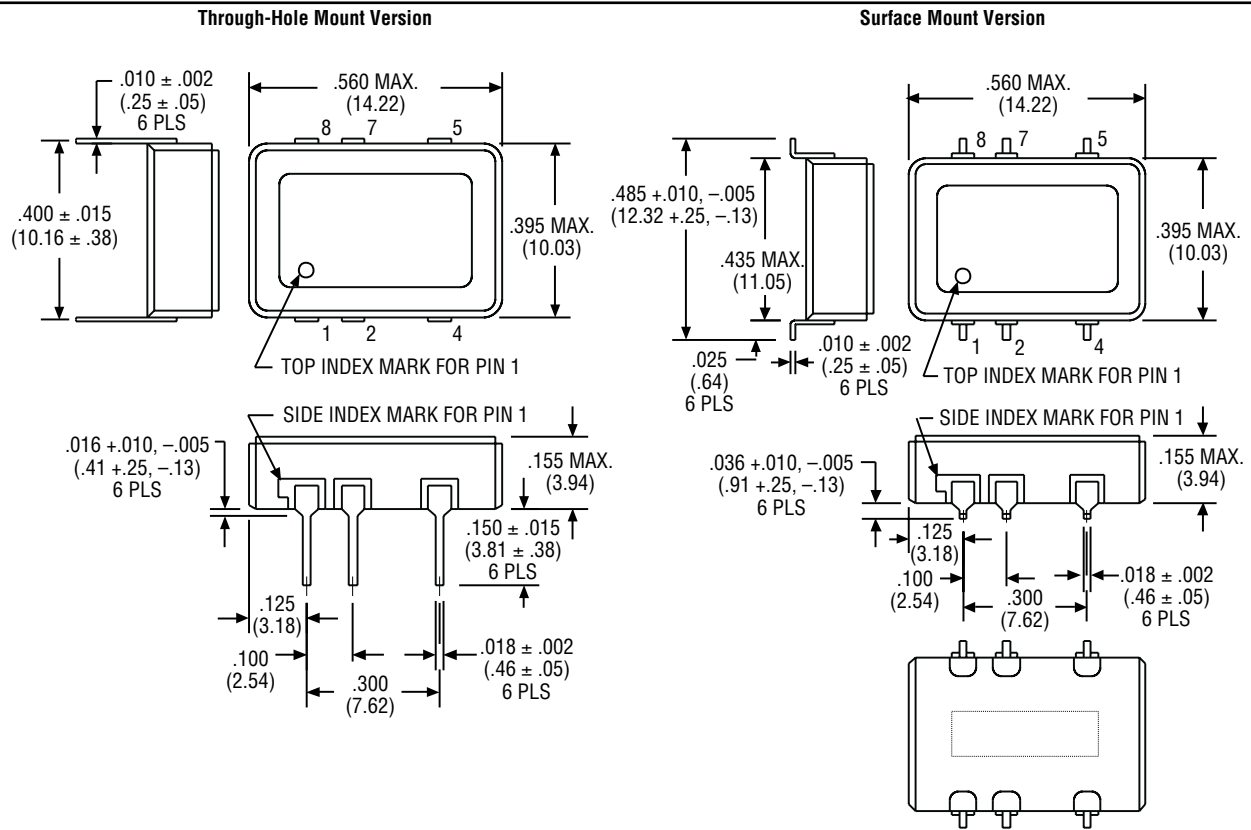



Figure 7 - Outline Dimensions



Notes

1. 2 terminal input configuration is compatible with CMOS or open collector TTL (with pull-up resistor). For Vcc levels above 6Vdc, a series limiting resistor is required. See Fig. 2 for resistor value. Use standard resistor value equal to or less than value from the curve.
2. Vcc = 5Vdc for all tests unless otherwise specified.
3. All DS13 Series relays may drive loads connected to either positive or negative referenced power supply lines. Reversing polarity of output may cause permanent damage. Inductive loads must be diode suppressed.
4. Transient blocking voltage & electrical system spike tests are performed per MIL-STD-704 (28Vdc systems).
5. To determine the maximum on-resistance at any given junction temperature, multiply on-resistance at 25°C by normalized on-resistance factor from curve (Fig. 4).
6. Overload testing per MIL-R-28750 is constrained to the limits imposed by the short circuit protection requirements of this specification and DSCC drawing 90091. Load circuit series inductance for "load shorted" mode of operation to be limited to 50mH max. Maximum repetition rate into a shorted load should not exceed 10 Hz. To calculate maximum on-resistance at any temperature, use the following equation: $R(on) = R(on) @ 25°C \times NF$ (without short circuit protection) and $R(on) = 0.2 \times NF + .21$ (with short circuit protection) where NF = normalized on-resistance factor from Fig. 4.
7. Proper operation of the status feedback requires a status pull-up resistor. Select the status resistor such that it limits status output current to 2mA: $R_{status} = V_{status} - 0.3V / 2mA$.



DC solid state relay for loads up to 2A @ 60Vdc

Product Facts

- Standard options: short circuit/overload protection, switch status and trip status.
- Optically coupled all solid state relay.
- TTL & CMOS compatible input.
- Low on-resistance power MOSFET output.
- Tested per MIL-R-28750 and approved to DSCC drawing 88062 with "Y" level screening.



DS11 series SSRs feature state of the art photo-voltaic optical isolation and power MOSFET output chips for ultra-reliable high speed switching of DC loads up to 2 amps, with extremely low on-resistance. Standard options include integral current overload/short circuit protection to provide protection of the relay, load

and wiring; and isolated switch status or trip status. The overload feature provides protection if a short or overload develops while the relay is in the on state or if the relay is turned on into a dead short. Switch status, optically isolated from the load, signals the status of the output and provides a logic "0" when

the output is off and a logic "1" when the output is on. Trip status, also optically isolated from the load, provides a logic "1" if the output trips off and a logic "0" when the output is in a normal condition, on or off, and is available only in conjunction with short circuit protection.

CII Part No.	DSCC Dwg. No.	Relay Version
DS11-1Y	88062-008	Basic relay
DS11-1000	88062-004	Relay w/ short circuit protection
DS11-1001	88062-006	Relay w/ switch status
DS11-1002	88062-002	Relay w/ short circuit protection and switch status
DS11-1003	N/A	Relay w/ short circuit protection and trip status

2 Terminal Input Configuration

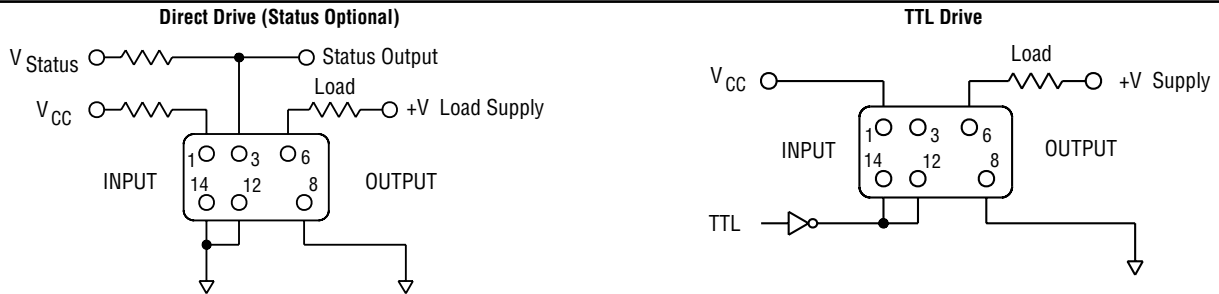

3 Terminal Input Configuration

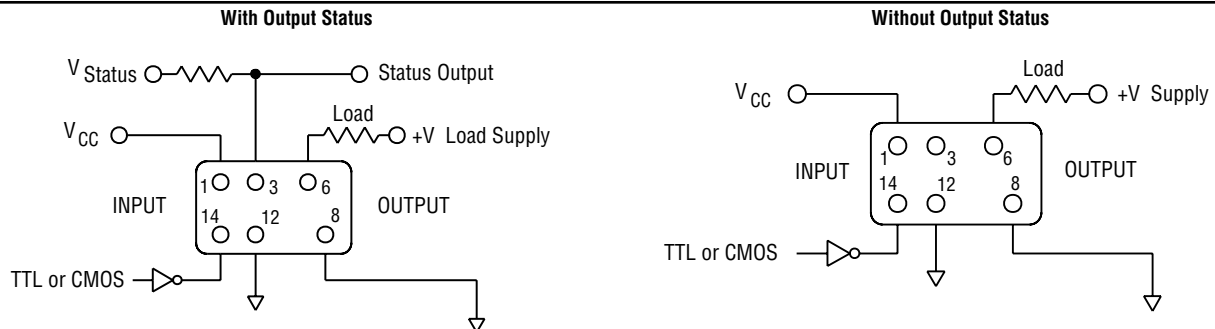



DC solid state relay for loads up to 2A @ 60Vdc (Continued)

Environmental Characteristics
Ambient Temperature Range:

 Operating: -55°C to +105°C.
 Storage: -55°C to +105°C.

Vibration Resistance:

100 G's, 10-3,000 Hz.

Shock Resistance:

50 G's, 11 ms pulse.

Constant Acceleration Resistance
(Y1 axis):

5,000 G's.

Mechanical Characteristics
Weight (approx.):

.176 oz. (5 grams)

Materials:

Header: Kovar

Cover: Nickel

Pins: Kovar, gold plated

Electrical Specifications (-55°C to +105°C unless otherwise specified)
Input (2 terminal configuration)

Input supply voltage range (Vcc)	3.8 - 32 Vdc (Notes 1 & 2, Figures 1 & 2)
Input current (max.) @ 5Vdc	15mAdc (Notes 1 & 2, Figures 1 & 2)
Must turn-on voltage	3.8Vdc
Must turn-off voltage	1.5Vdc
Reverse voltage protection	-32Vdc

Input (3 terminal configuration)

Control voltage range	0 - 18 Vd
Control current (max.)	250µAdc @ 5V, 1mA @ 18V
Input supply voltage range (Vcc)	3.8 - 32 Vdc (Notes 1 & 2, Figures 1 & 2)
Input current (max.) @ 5Vdc	15mADC (Notes 1 & 2, Figures 1 & 2)
Must turn-on voltage	0.3Vdc
Must turn-off voltage	3.2Vdc

I/O

Dielectric strength (min.)	1,000V rms
Insulation resistance (min.) @ 500Vdc	10 ⁹ ohms
Capacitance (max.)	10pF

Output

Continuous load current (max.) @ 25°C	2.1Adc (Figure 7)
Continuous load voltage (max.)	60Vdc
Transient blocking voltage (max.)	80Vdc (Note 5)
On resistance (max.) @ T _j = 25°C, I _L = 100mA	0.15 ohm (Note 6, Figure 6)
Output voltage drop (max.)	0.5Vdc
Leakage current (max.) @ V = 60Vdc	100µAdc
Leakage current (max.) @ V = 60Vdc, with switch status	2mAdc
Turn-on time (max.)	3 ms (Figure 3)
Turn-off time (max.)	1 ms (Figure 3)
dv/dt (min.)	100V / µs
Electrical system spike	600Vdc (Note 5)
Output chip junction temperature (max.)	125°C
Thermal resistance (max.), junction to ambient	90°C/W
Thermal resistance (max.), junction to case	25°C/W

Status

Status supply voltage range	1 - 18Vdc
Status current (max.) @ V _{status} ≤ 0.4Vdc	600µADC (Figure 5, Note 8)
Status leakage current (max.) @ 16Vdc	10µAdc
Status turn-on time (max.)	3.5 ms (Figure 4)
Status turn-off time (max.)	8 ms (Figure 4)

Short Circuit Protection

Current surge without tripping (max.), 100ms pulse	4.25Adc
Overload trip current (max.), 0.5 ms pulse, V = 60Vdc	10Adc
Trip time (typical), turning on into short	400µs
Trip time (typical), shorting while relay is on	280µs

Figure 1 - Maximum Input Current vs. Input Voltage

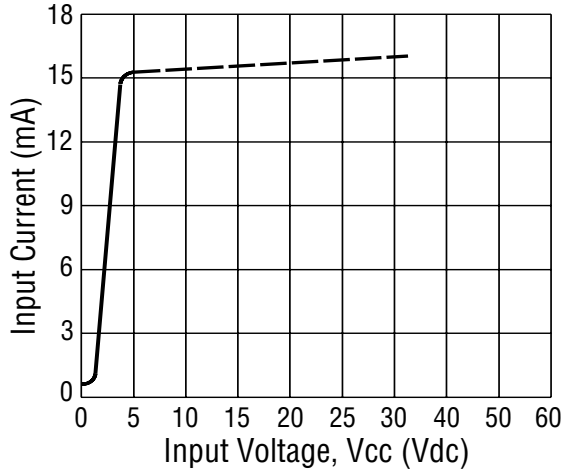

Figure 2 - Series Resistance vs. Vcc Supply Voltage (Note 1)

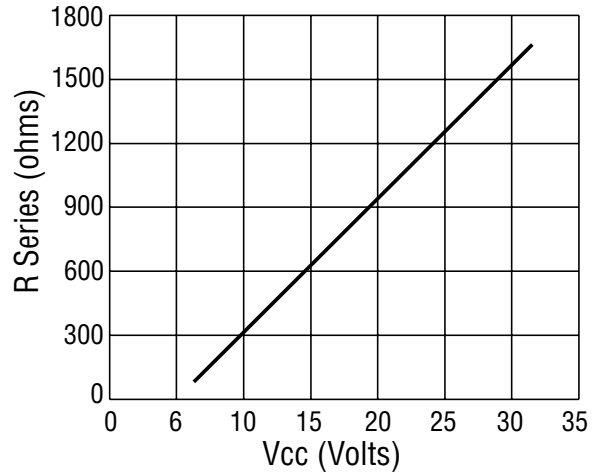

Figure 3 - Turn-on and Turn-off Timing

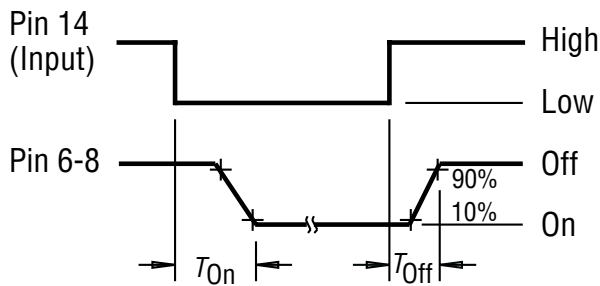

Figure 4 - Output Status Timing

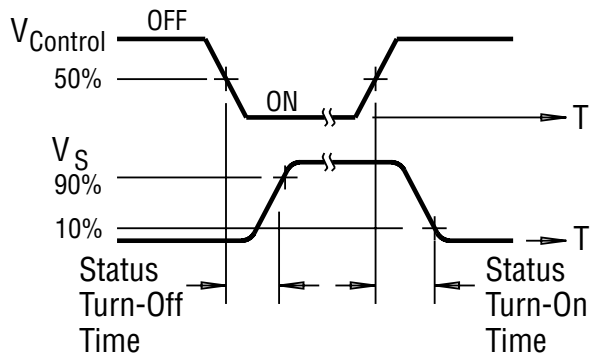

Figure 5 - Status Resistor vs. Status Supply Voltage

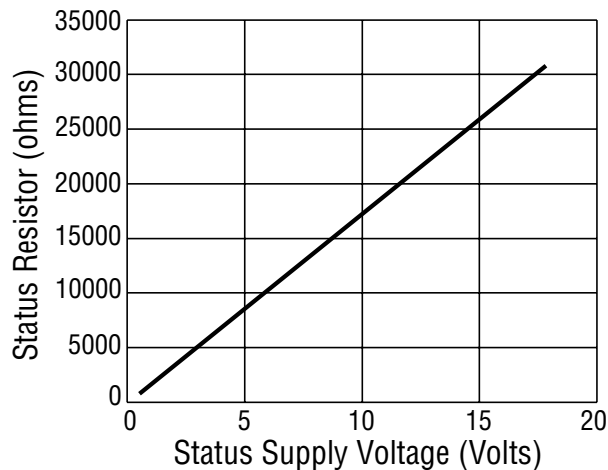

Figure 6 - On-Resistance vs. Temperature (Note 6)

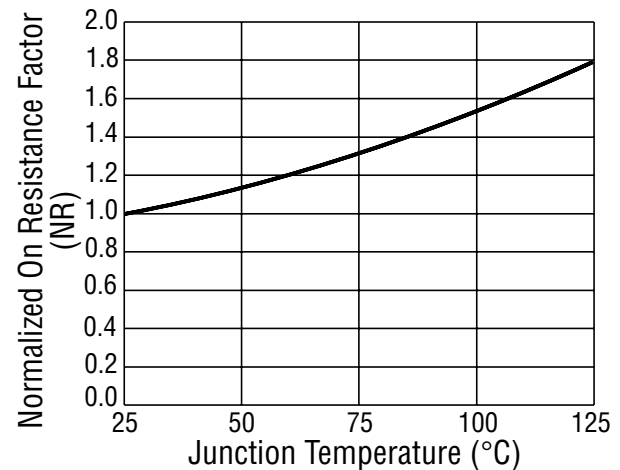

Figure 7 - Temperature Derating Curve

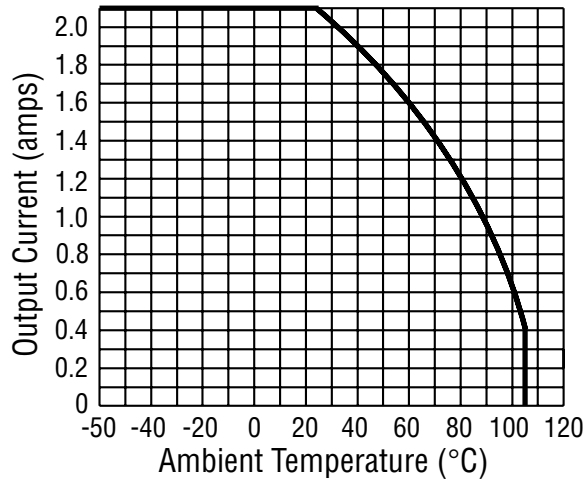

Figure 8 - Maximum Surge Current Without Tripping

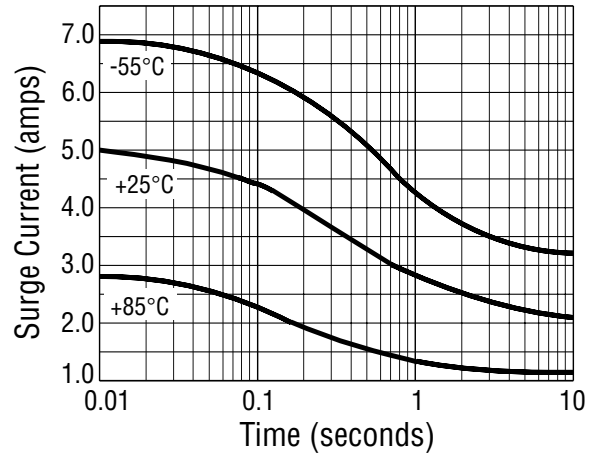
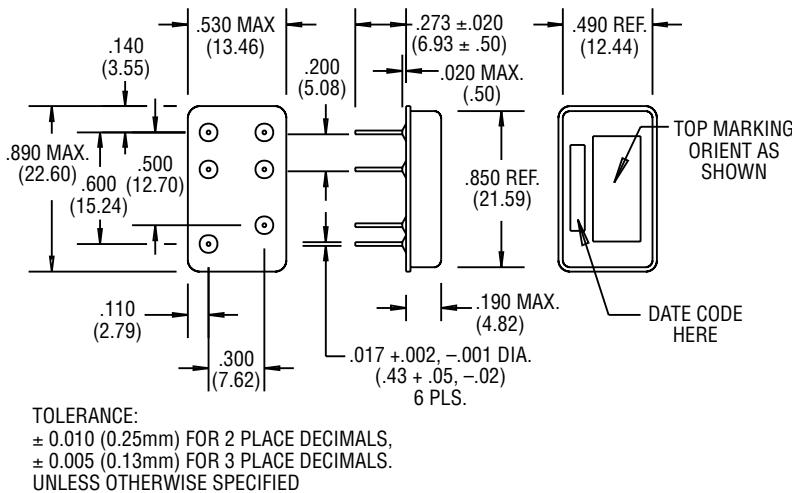

Figure 9 - Outline Dimensions



Notes

1. 2 terminal input configuration is compatible with CMOS or open collector TTL (with pull-up resistor). For Vcc levels above 6Vdc, a series limiting resistor is required. See Fig. 2 for resistor value. Use standard resistor value equal to or less than value from the curve.
2. Input transitions to be ≤ 1ms duration, and input direct drive should be “bounceless contact” type.
3. Vcc = 5Vdc for all tests unless otherwise specified.
4. All DS11 Series relays may drive loads connected to either positive or negative referenced power supply lines. Reversing polarity of output may cause permanent damage. Inductive loads must be diode suppressed.
5. Transient blocking voltage and electrical system spike tests are performed per MIL-STD-704 (28VDC systems).
6. To determine the maximum on-resistance at any given junction temperature, multiply on-resistance at 25°C (0.15 ohm) by normalized on-resistance factor from curve (Fig. 6).
7. Overload testing per MIL-R-28750 is constrained to the limits imposed by the short circuit protection requirements of this specification and DSCC drawing 88062. Load circuit series inductance for “load shorted” mode of operation to be limited to 50mH max. Maximum repetition rate into a shorted load should not exceed 10 Hz.
8. Proper operation of the status feedback requires a status pull-up resistor. See Fig. 5 for status resistor value.



AC solid state relay for loads up to 1A @ 250Vrms (2A with heatsink)

Product Facts

- Qualified to Mil-R-28750C (Mil p/n M28750/9-001Y).
- Optically coupled all solid state relay.
- TTL compatible input.
- Zero voltage turn-on for low EMI.
- Hermetically sealed low profile metal DIP package.

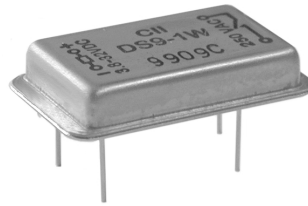

This PC board mountable solid state relay is designed for low power AC load switching up to 1 amp at 250Vrms (2 amps with heatsink). The circuit employs back-to-back photo SCRs with zero

voltage turn-on for reliable switching of resistive or reactive loads. TTL compatible input circuitry is optically isolated to 1,500Vrms from the AC load circuit. The relay is offered in two versions: the

MIL qualified JDS9-1Y with "Y" level screening per Mil-R-28750C and the DS9-1W tested per Tyco Electronics specifications for CII relays, equivalent to former "W" level screening.

CII Part Number	Military Part Number	Screening Level
JDS9-1Y	M28750/9-001Y	Y
DS9-1W	N/A	W

Circuit Diagram

Terminal View

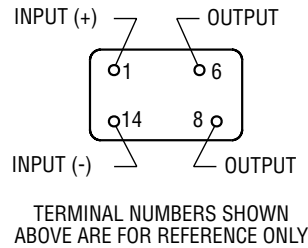

Outline Drawing

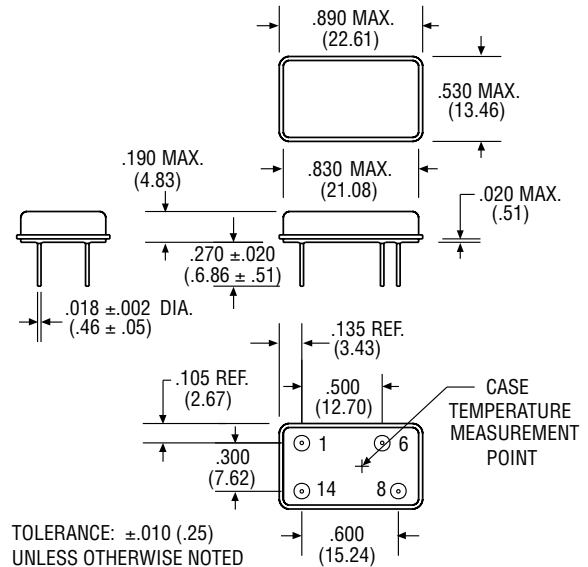



AC solid state relay for loads up to 1A @ 250Vrms (2A with heatsink) (Continued)

Environmental Characteristics

Ambient Temperature Range:

Operating: -55°C to +110°C.
Storage: -55°C to +125°C.

Vibration Resistance:

20 G's, 10-2,000 Hz.

Shock Resistance:

1,500 G's, 0.5 ms pulse.

Acceleration Resistance (Y axis):

5,000 G's.

Mechanical Characteristics

Weight (typical):

.176 oz. (5 grams)

Materials:

Header: Kovar
Pins: Kovar, gold plated
Cover: Nickel.

Electrical Specifications (-55°C to +105°C unless otherwise specified)

Input

Input supply voltage range (Vcc)	3.8 - 32 Vdc
Input current (max.) @ 5Vdc	15mA _{dc}
Must turn-on voltage	3.8V _{dc}
Must turn-off voltage	1.5V _{dc}
Reverse voltage protection	-32V _{dc}

I/O

Dielectric strength (min.)	1,500V rms/60 Hz.
Insulation resistance (min.) @ 500VDC	10 ⁹ ohms
Capacitance (max.)	10pF

Output

Output current rating (max.)	2A rms (Fig. 2, Note 1)
Surge current, 16ms @ 25°C (max.)	8A pk (Fig. 1, Note 3)
Continuous load voltage (max.)	250V rms
Transient blocking voltage (max.)	500V pk
Frequency range	40 - 440 Hz.
Output voltage drop (max.) @ 1A load current	1.5V rms
Off-state leakage current (max.) @ 250V rms/400 Hz.	1mA rms
Turn-on time (max.)	1/2 cycle
Turn-off time (max.)	1 cycle
Off-state dv/dt (min.), with snubber	200V /μs (Note 2)
Zero voltage turn-on window, initial (max.)	10V
Waveform distortion (max.)	4V rms
Output chip junction temperature (max.)	130°C
Thermal resistance (max.), junction to ambient	65°C/W
Thermal resistance (max.), junction to case	15°C/W

Notes

1. Operation at elevated load currents up to 2 amps is dependent on use of suitable heatsink to maintain case temperature per Fig. 2.
2. Recommended output snubber: R = 100 ohms (1/2 W), C = .01μF (600V).
3. Heating of output chip during and after a surge may cause loss of output blocking capability until junction temperature falls below maximum rating.

Figure 1 - Peak Surge Current vs. Surge Current Duration

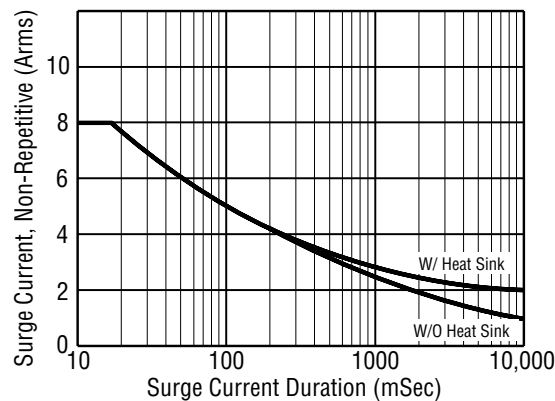
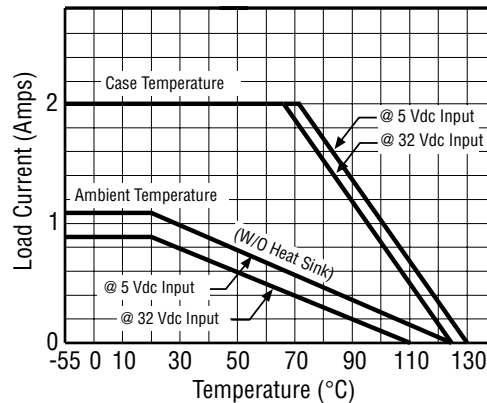

Figure 2 - Load Current vs. Temperature



C

C

SINGLE POLE, HALF SIZE HIGH PERFORMANCE RELAY

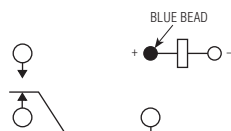

TERMINAL VIEW

FEATURES

- Hermetically sealed
- Up to 10 amps switching
- High shock & vibration ratings
- Optional terminals & mounting styles

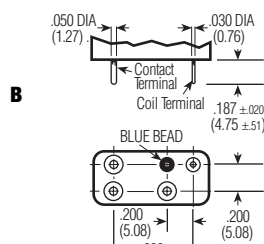
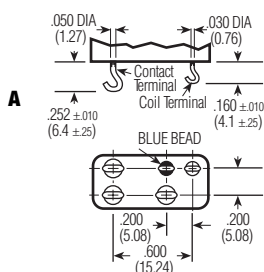

TERMINALS

ELECTRICAL CHARACTERISTICS

CONTACT ARRANGEMENT

1 Form C (SPDT)

CONTACT MATERIAL

Stationary: Hardened silver alloy

Moveable: Hardened silver alloy

CONTACT RESISTANCE

Before Life: 50 Milliohms max.
(measured at 10 mA @ 6 Vdc)

After Life: 100 Milliohms max.
(measured @ 1 A @ 28 Vdc)

CONTACT RATING

Contact Load: 10 A 28 Vdc

Type: Resistive

Operations min. 50,000

MECHANICAL LIFE EXPECTANCY

1 million operations min.

COIL VOLTAGE

6 to 26.5 Vdc

COIL POWER

1.4 watts max. @ 25°C

DUTY CYCLE

Continuous

PICK-UP VOLTAGE

Approximately 50% of nominal coil voltage

PICK-UP SENSITIVITY

260 mW

OPERATIONAL CHARACTERISTICS

TIMING

Operate Time: 5.0 ms max.

Release Time: 5.0 ms max.

CONTACT BOUNCE

5.0 ms max.

DIELECTRIC WITHSTANDING VOLTAGE

Between Open Contacts:

500 Vrms 60 Hz

Between Adjacent Contacts:

1000 Vrms 60 Hz

Between Contacts and Coils:

1000 Vrms 60 Hz

INSULATION RESISTANCE

1,000 megohms min. @ 500 Vdc

ENVIRONMENTAL CHARACTERISTICS

TEMPERATURE RANGE

-65°C to +125°C

WEIGHT

0.28 oz. (8 grams) max.

VIBRATION RESISTANCE

20 G's, 10 to 2,000 Hz

SHOCK RESISTANCE

100 G's, 6 ± 1 ms

DESIGNED TO

MIL-R-39016

AW

BW

EW

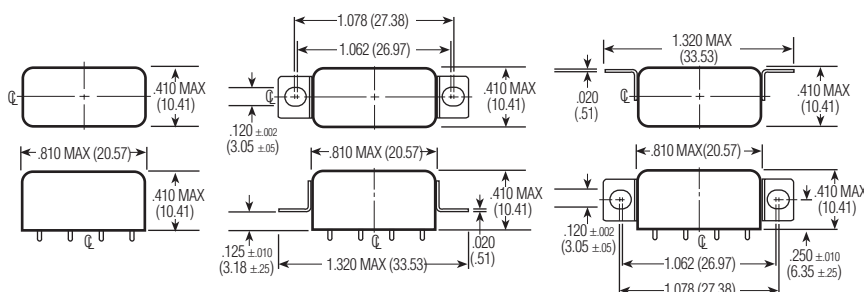

MOUNTING STYLES

STANDARD COIL DATA

NOM. COIL VOLTAGE (Vdc)	COIL RESISTANCE IN OHMS ±10% @ 25°C	PICKUP VOLTAGE Vdc (MAX.) @ 25°C	PICKUP VOLTAGE Vdc (MAX.) @ 125°C	DROP-OUT VOLTAGE Vdc (MIN.) @ 25°C	DROP-OUT VOLTAGE Vdc (MIN.) @ -65°C	NOM. COIL POWER (W) @ 25°C	MAX. COIL VOLTAGE	COIL DESIG.
6.0	40	3.5	4.5	0.45	0.3	.9	8.0	6
12.0	160	6.5	9.0	0.9	0.6	.9	15.0	12
26.5	700	14.0	18.0	1.8	1.2	1.0	32.0	24

SPECIFYING A PART NUMBER EXAMPLE:

TYPE C MOUNTINGS BW- CONTACTS 1C- COILS 24 TERMINALS B





Product Facts

- 320 to 480 Hz. frequency sensor
- 1 or 2 Form C (SPDT or DPDT) contacts
- Hermetic package
- Many customizing options
 - 50 or 60 Hz. Sensing
 - Dual trip points
 - Tighter accuracy
 - Enclosures
 - Higher temperature range
 - Up to 4 Form C (4PDT)
 - 10A contacts



CII 7000 series frequency sensor utilizes an integrated circuit digital logic design to determine, cycle by cycle, whether a given input signal is within a predetermined frequency pass band. Typical application is in monitoring MIL-STD-704 power systems.

Part Numbering System

Typical Part Number	7000	-2	B	-380
Model Number:	7000 - Frequency Sensor.			
Contact Arrangement:	1 = 1 Form C (SPDT)		2 = 2 Form C (DPDT)	
Mounting (see outline dimension drawings):	A = Studs on bottom B = Studs on top C = Studs on side			
Frequency Trip Point:	Three-digit code for any value between 320 Hz. and 480 Hz.			

Electrical Specifications

- Input Voltage:** 95 to 135Vac, 400 Hz.
- Frequency Range:** 320 to 480 Hz.
- Accuracy:** ±2%.
- Contact Arrangement:** 1 Form C (SPDT) or 2 Form C (DPDT).
- Contact Ratings:** 4A resistive @ 30Vdc. 2A resistive @ 115 Vrms, 400 Hz.
- Current Drain:** 150mA maximum.
- Hysteresis:** 0.5% from trip point

Environmental Specifications

- Temperature Range:** -55°C to +85°C.
- Vibration:** 20 G's, 10 - 2,000 Hz.
- Shock:** 50 G's, 11 ± 1ms duration.
- Insulation Resistance:** 1,000 megohms, min., at 500Vdc, all terminals to case.
- Dielectric Strength:** 1,000Vrms, 60 Hz., at sea level, all terminals to case.
- Sealing:** Hermetic, 1.3 in. (33.0mm) of mercury.
- Life:** 100,000 operations, min.
- Weight:** 8.5 oz (240g) max.

Function Diagram

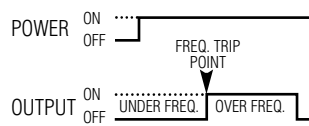

Outline Dimensions

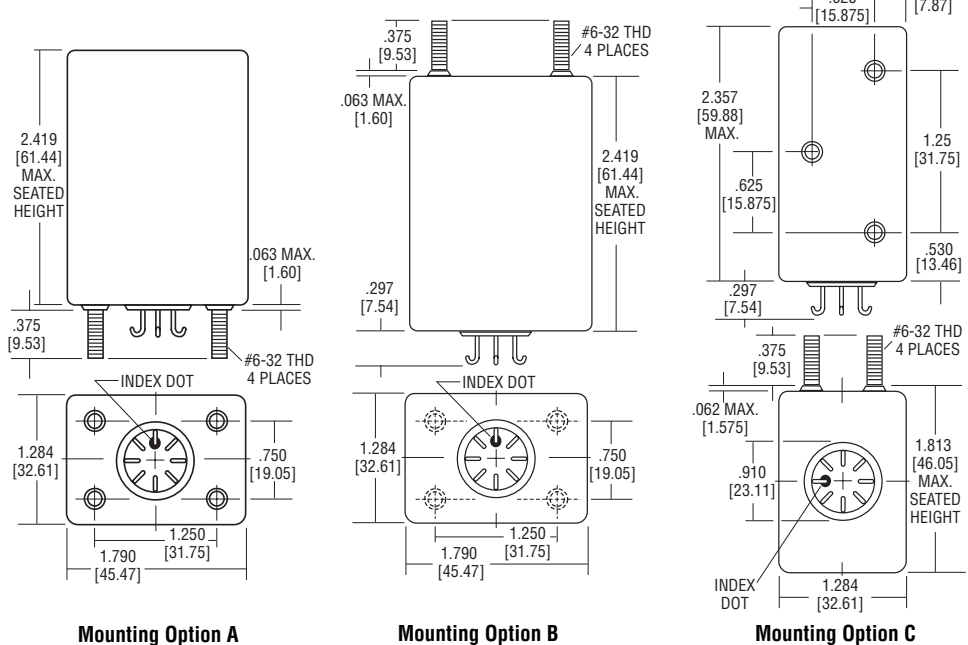

Wiring Diagrams

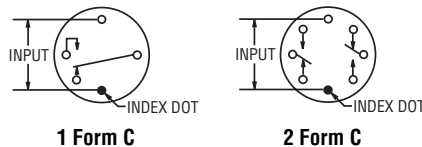

© 2006 by Tyco Electronics Corporation. All Rights Reserved.
CII and TYCO are trademarks.
Other products and company names mentioned herein may be trademarks of their respective owners.



Product Facts

- AC/DC input delay on operate timer offered in fixed (1600) and adjustable (1700) types
- Up to 10A loads
- CMOS digital design
- Hermetic package
- Built to MIL-R-83726 environmentals
- Many customizing options
 - Extended timing ranges
 - Tighter timing tolerances
 - Header and mounting
 - 115Vac, 60 Hz. input types



CII 1600/1700 series delay on operate timers combine solid state timing circuits with electromechanical output relays in robust hermetically

sealed enclosures. The 1600 types are fixed timers, while the 1700 models are adjustable via an external resistor. Numerous output options include 4A rated

contacts in 1-4 form C (SPDT - 4PDT) arrangements and 10A rated contacts in 1-2 form C (SPDT-DPDT) arrangements.

Electrical Specifications

Timing Range:

1600 series (fixed): 50 ms to 600 s.
1700 series (adjustable): 50 ms to 240 s.

Tolerance: ±10% or 10 ms, whichever is greater.

Recycle Time: 10 ms (DC input), 50ms (AC input).

Recovery Time: 10 ms (DC input), 50ms (AC input).

Input Voltage: 18 to 31Vdc, 105 to 125Vac, 400 Hz.

Current Drain (at 25°C, 28Vdc):

DC Coil, 10A contacts:
1- and 2-pole: 135mA maximum.

AC or DC Coil, 4A contacts:

1-pole: 100mA maximum.

2-pole: 150mA maximum.

3- and 4-pole: 200mA maximum.

Contact Ratings:

DC Coil, 10A contacts:

10A resistive @ 30Vdc.

5A inductive @ 30Vdc.

5A resistive @ 115 Vrms, 400 Hz

3A inductive @ 115 Vrms, 400 Hz

AC or DC Coil, 4A contacts:

4A resistive @ 30Vdc.

1A inductive @ 30Vdc.

2A resistive @ 115 Vrms, 400 Hz

1A inductive @ 115 Vrms, 400 Hz

Environmental Specifications

Temperature Range:

-55°C to +85°C or -55°C to +125°C.

Vibration: 20 G's, 10 - 2,000 Hz.

Shock: 50 G's, 11 ± 1ms duration.

Insulation Resistance: 1,000 megohms, min., at 500Vdc, all terminals to case.

Dielectric Strength: 1,000Vrms, 60 Hz., at sea level, all terminals to case.

Sealing: Hermetic, 1.3 in. (33.0mm) of mercury.

Life: 100,000 operations, min.

Weight:

4A units: 4.5 oz (127.6g) max.

10A units: 8.5 oz (240g) max.

Specifications by Model Number – 4 Amp Contact Versions

Fixed Timer Model Number	Adjustable Timer Model Number	Input Voltage	Temperature Range	Housing Length (Dim. "A")	Contact Arrangement
1601	1701	DC	-55°C to +85°C	1.656 [42.06]	1 Form C (SPDT)
1602	1702	DC	-55°C to +85°C	1.656 [42.06]	2 Form C (DPDT)
1603	1703	DC	-55°C to +85°C	2.0 [50.8]	3 Form C (3PDT)
1604	1704	DC	-55°C to +85°C	2.0 [50.8]	4 Form C (4PDT)
1621	1721	DC	-55°C to +125°C	1.656 [42.06]	1 Form C (SPDT)
1622	1722	DC	-55°C to +125°C	1.656 [42.06]	2 Form C (DPDT)
1623	1723	DC	-55°C to +125°C	2.0 [50.8]	3 Form C (3PDT)
1624	1724	DC	-55°C to +125°C	2.0 [50.8]	4 Form C (4PDT)
1651	1751	AC	-55°C to +85°C	2.0 [50.8]	1 Form C (SPDT)
1652	1752	AC	-55°C to +85°C	2.0 [50.8]	2 Form C (DPDT)
1653	1753	AC	-55°C to +85°C	2.375 [60.33]	3 Form C (3PDT)
1654	1754	AC	-55°C to +85°C	2.375 [60.33]	4 Form C (4PDT)
1671	1771	AC	-55°C to +125°C	2.0 [50.8]	1 Form C (SPDT)
1672	1772	AC	-55°C to +125°C	2.0 [50.8]	2 Form C (DPDT)
1673	1773	AC	-55°C to +125°C	2.375 [60.33]	3 Form C (3PDT)
1674	1774	AC	-55°C to +125°C	2.375 [60.33]	4 Form C (4PDT)

Specifications by Model Number – 10 Amp Contact Versions

Fixed Timer Model Number	Adjustable Timer Model Number	Input Voltage	Temperature Range	Housing Length (Dim. "A")	Contact Arrangement
1610	1710	DC	-55°C to +85°C	2.419 [61.44]	1 Form C (SPDT)
1620	1720	DC	-55°C to +85°C	2.419 [61.44]	2 Form C (DPDT)

Adjustable Timing Formula (1700 types)

The resistance required to obtain timing within this range is determined by using the formula:

$R_x = 400K (T/T_{max}) - 40K$, where

R_x = External Resistance in Ohms,

T - Desired Time in Seconds, and

T_{max} = Maximum Time (Code).

A high quality deposited carbon ±1%, 0.1W (min.) resistor is recommended for external resistance.

Part Numbering System

Typical Part Number

1722

-C

-1102

Model Number:

Four digit code from table above.

Mounting (see outline dimension drawings):

A = Studs on bottom B = Studs on top C = Studs on side

Timing Code:

Four-digit code for any value between 50ms and 600s for fixed (1600) timers, and 50ms and 240s for adjustable (1700) timers.

The timing code consists of four digits and gives the time in ms. The first three digits are the significant figures and the last digit is the number of zeros following the significant figures; thus 50 ms would be coded 0500, 1.1 s would read 1101, and 1 m (60 s) would be 6002.

Adjustable timers cover one decade, e.g., 62 ms to 620 ms. The upper decade limit is T_{max} in the timing formula and is the value defined by the timing code in the part number.

A typical part number for an adjustable timer would be 1722-C-1102. This is a DC unit in the -55°C to +125°C temperature range with a 2 form C (DPDT) contact arrangement in a style "C" mounting, with a maximum time delay of 11s.

© 2005 by Tyco Electronics Corporation. All Rights Reserved.

CII and TYCO are trademarks.

Other products and company names mentioned herein may be trademarks of their respective owners.



1600/1700 Series Delay On Operate Timers (Continued)

Outline Dimensions

10 Amp Units

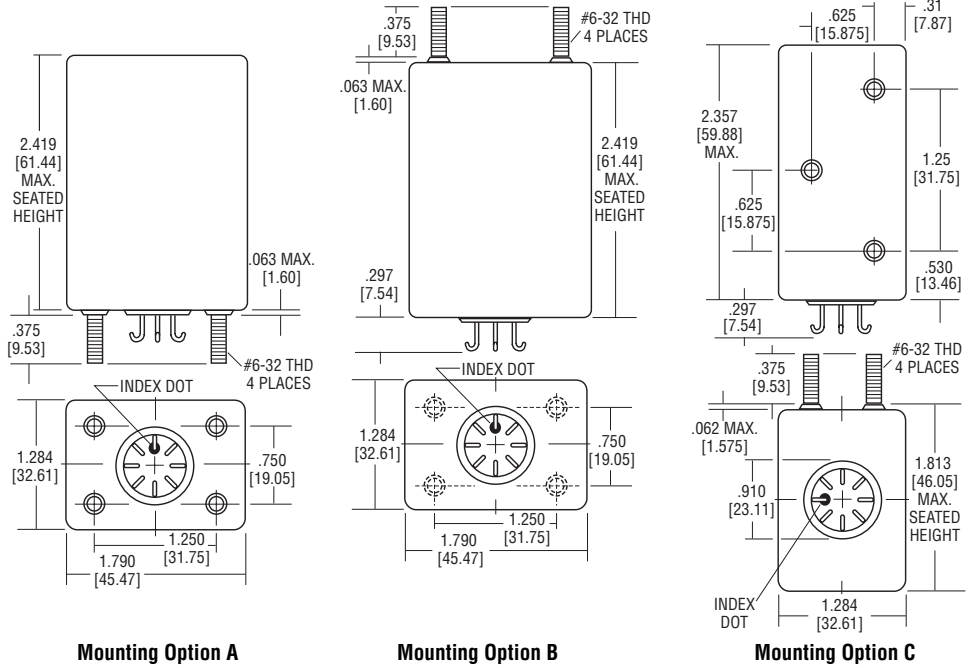

4 Amp Units

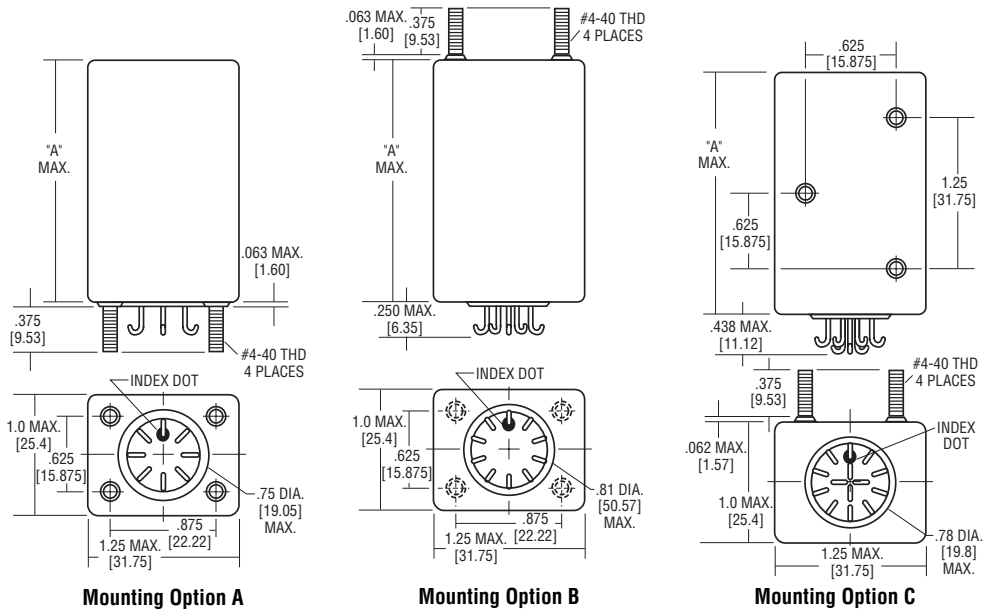

Wiring Diagrams

1600 Series (Fixed)

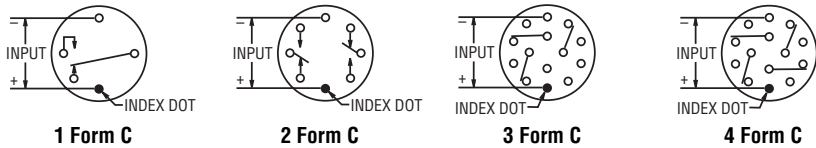

1700 Series (Adjustable)

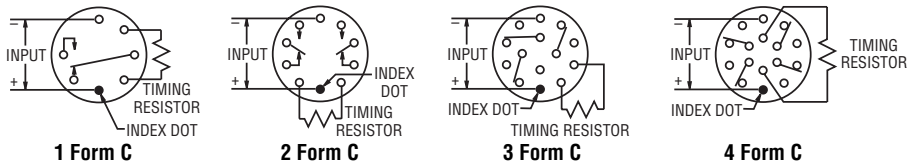



Product Facts

- Phase sensor for 115 or 208Vac, 60 or 400 Hz.
- Up to 2A loads
- Static and motor load types
- Hermetic package
- Built to MIL-R-83726 environmental standards
- Various applications
 - Motor protection
 - Brown-out protection
 - Power supply sequencing
 - Air conditioner protection
 - Ground support equipment protection
- Many customizing options
 - 50 Hz. input types
 - Contact ratings to 10A
 - Higher voltages
 - Different packages, headers and mounting



CII 1400 series phase sensors combine solid state sensing circuits with electromechanical output relays in robust hermetically sealed enclosures.

P-Type models are for static loads. With the line voltage and frequency are within operating limits, P-Type units will energize only when input phases are in sequence A-B-C. They will de-energize only when power is removed. The P-Type unit is

best suited to applications where static loads are used and where regenerated voltage will not be present if a phase opens.

Q-Type units perform the same function as the P-Type since they will energize only when input phases are in sequence A-B-C. In addition, the Q-Type unit will de-energize when any phase is disconnected or grounded, provided

the voltage input to the unit is below 50% of the nominal phase-to-phase voltage input. Q-Type units are suitable for motor loads where regenerated voltage is produced.

Neither P-Type nor Q-Type units require connection to the neutral leg.

For high-current applications, phase sensors are used with slave relays having heavy duty contact ratings.

Electrical Specifications

Input Data:

Voltage: 115 or 208Vac.
Frequency: 60 or 400 Hz.

Operate Time (Max.): 75 ms.

Release Time (Max.): 100 ms.

Contact Arrangement: 1 Form C (SPDT).

Contact Ratings:

2A resistive @ 30Vdc.
0.5A inductive @ 30Vdc.
0.25A resistive or inductive @ 115 Vrms, 60 or 400 Hz.

Environmental Specifications

Temperature Range:

-55°C to +85°C.

Vibration: 20 G's, 10 - 2,000 Hz.

Shock: 50 G's, 11 ± 1ms duration.

Insulation Resistance: 1,000 megohms, min., at 500Vdc.

Dielectric Strength: 1,000Vrms, 60 Hz., at sea level, all terminals to case.

Sealing: Hermetic, 1.3 in. (33.0mm) of mercury.

Life: 100,000 operations, min.

Weight: 12 oz (340g) max.

Specifications by Model Number

Fixed Timer Model Number	Load Type	Line to Line Voltage ±10%	Frequency ±10%	Max. Power Required	Mounting Style Figure
1407	P	115V	60 Hz.	4 Watts	3
1408	P	115V	400 Hz.	4 Watts	1 or 3
1409	P	208V	60 Hz.	6 Watts	3
1410	P	208V	400 Hz.	6 Watts	3
1437	Q	115V	60 Hz.	6 Watts	2
1438	Q	115V	400 Hz.	6 Watts	3
1439	Q	208V	60 Hz.	9 Watts	4
1440	Q	208V	400 Hz.	9 Watts	4

Typical Applications Connections

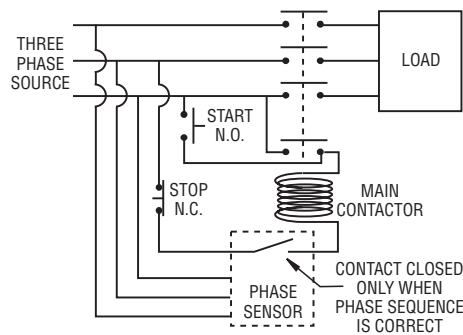

Wiring Diagram

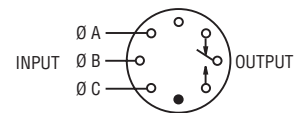

Part Numbering System

Typical Part Number

1408 -1 A

Model Number:

Four digit code from table above.

Output:

1 = 1 Form C (SPDT)

Mounting (see outline dimension drawings):

A = Studs on bottom B = Studs on top, except bracket on bottom for 1439 and 1440 C = Studs on side

A typical part number would be 1408-1A. This is a 115Vac, 400 Hz., "P" type phase sensor with a 1 form C (SPDT) contact arrangement in a style "A" mounting.



1400 Series Phase Sensors (Continued)

Outline Dimensions

Figure 1
Applicable to 1408

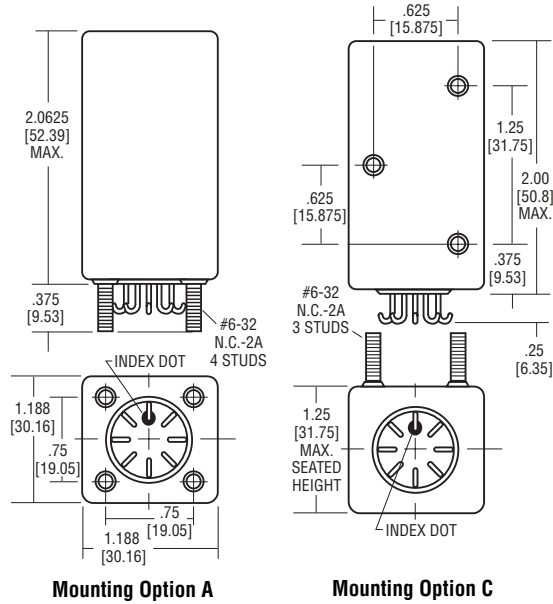

Figure 2
Applicable to 1437

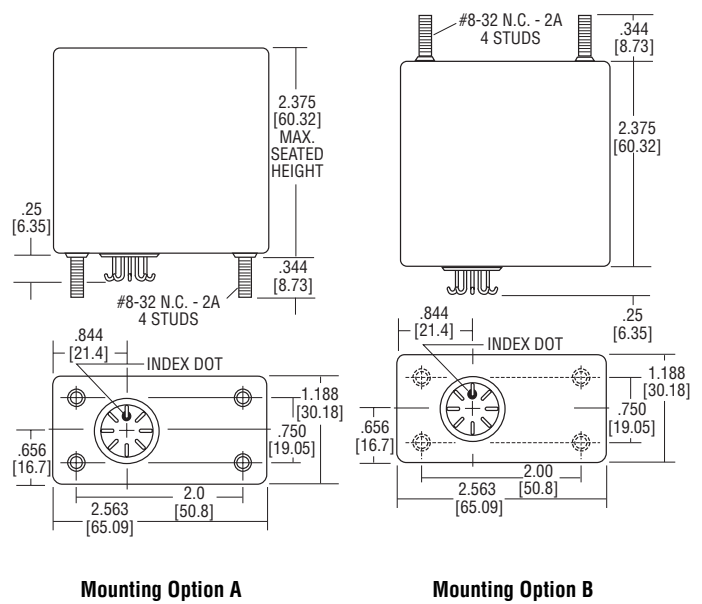

Figure 3
Applicable to 1407, 1409, 1410, 1438 and 1408 "B" revision only

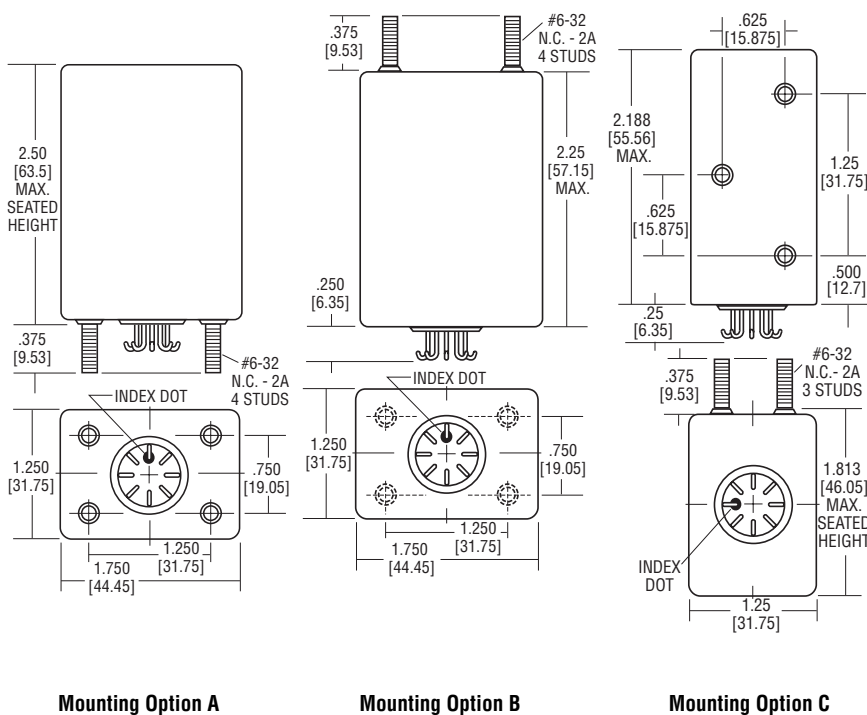
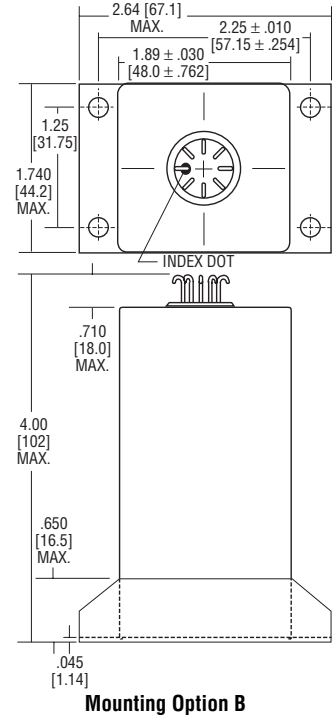

Figure 4
Applicable to 1439 and 1440



Product Facts

- **Standard models combine AC (400 Hz.) voltage-sensing circuit with 2A DPDT output relay.**
- **Various applications**
 - Motor protection
 - Ground support equipment
 - Low or high line alarms
 - Computer protection
- **Many customizing options**
 - Solid state output
 - Two-stage sensing (voltage band)
 - Up to 10A relay output
 - 3 phase version
 - Controlled dropout differential
 - Operate with auxiliary control voltage
 - Under and over voltage trip
 - Time delay on trip point
 - Tighter accuracy
 - Lower trip points
 - Different package, mounting, header
 - 60 Hz. versions



The CII 1350 series AC voltage sensor energizes a relay when the monitored power line voltage reaches a predetermined level. This rugged unit with reliable solid-state design provides precise, repeatable operation over a

wide temperature range. The input voltage is fed into a temperature compensated comparator circuit. When the input reaches the preset level, transistor amplifiers switch the output relay. This output may control any external devices,

process or warning system to protect expensive equipment. The unit is potted and hermetically sealed and is designed to meet the environmental requirements of MIL-R-83726.

Electrical Specifications

Pull-In Voltage: Any voltage level between 50 to 150Vac, 400 Hz., in 1.0 volt increments.

Drop-Out Voltage: 0 to 3.0V max, (1.5V nom.) below pull-in voltage.

Current Drain: 100mA max @ 25°C.

Accuracy: ±2.5% of set point over temperature range.

Max. Allowable Applied Voltage: 150% of specified pull-in voltage.

Auxiliary Voltage: None required.

Operate and Release Times: 50ms max. over the temperature range.

Contact Arrangement: 2 Form C (DPDT).

Contact Rating:

2 amps resistive @30Vdc
300mA resistive @ 115 Vrms, 400 Hz.

Environmental Specifications

Temperature Range: -55°C to +125°C.

Vibration: 20G's, 10 - 2,000 Hz.

Shock: 50 G's, 11 ± 1ms duration.

Insulation Resistance: 1,000 megohms, min., at 500Vdc, all terminals to case.

Dielectric Strength: 1,000Vrms, 60 Hz., at sea level, all terminals to case.

Sealing: Hermetic, 1.3 in. (33.0mm) of mercury.

Life: 100,000 operations, min.

Weight: 3.5 oz (99.2g) max.

Outline Dimensions

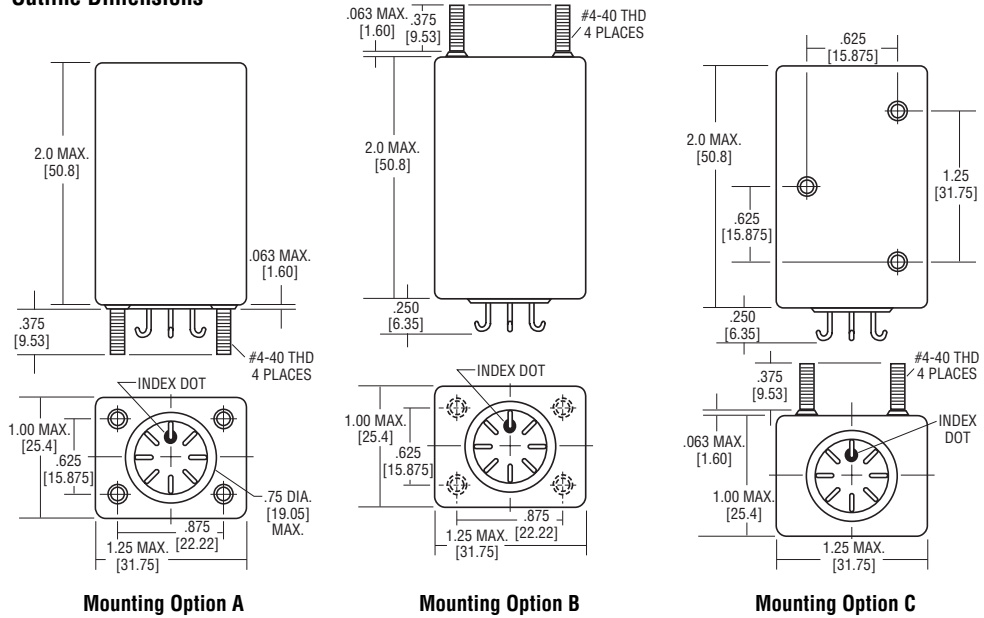

Wiring Diagram

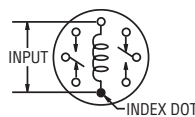

Part Numbering System

Typical Part Number	1350	- 2	A	- 100.0
Series:	1350 = AC Voltage Level Sensor, Relay Output			
Contact Form:	2 = 2 Form C (DPDT)			
Mounting (see outline dimension drawings):	A = Studs on bottom B = Studs on top C = Studs on side			
Pull-In Voltage:	Specify any level between 50 and 150Vac in 1.0 volt increments			

© 2006 by Tyco Electronics Corporation. All Rights Reserved.
CII and TYCO are trademarks.

Other products and company names mentioned herein may be trademarks of their respective owners.



Product Facts

- Standard models combine DC voltage-sensing circuit with 2A DPDT output relay.
- Various applications
 - Battery protection
 - Computer protection
 - Low or high voltage alarms
- Many customizing options
 - Solid state output
 - Two-stage sensing (voltage band)
 - Up to 10A relay output
 - Controlled dropout differential
 - Operate with auxiliary control voltage
 - Time delay on trip point
 - Tighter accuracy
 - Different package, mounting, header



The CII 1310 series DC voltage sensor is essentially a voltage monitoring device operating a snap-action transistor circuit with low drift and inherent temperature compensation. This device will either open or

close a circuit when a predetermined voltage is present at the input. By using a CII electromechanical relay as the output of the voltage sensor, a positive switching action can be achieved with

very close differential between pull-in and drop-out voltages. The unit is potted and hermetically sealed and is designed to meet the environmental requirements of MIL-R-83726.

Electrical Specifications

- Pull-In Voltage:** Any voltage level between 10 to 150Vdc.
- Drop-Out Voltage:** 0 to 0.5V below pull-in voltage.
- Current Drain:** 15mA max @ 25°C.
- Accuracy:** ±2.5% of set point over temperature range.
- Max. Allowable Applied Voltage:** 150% of specified pull-in voltage.
- Auxiliary Voltage:** None required.
- Operate and Release Times:** 50ms max. over the temperature range.
- Contact Arrangement:** 2 Form C (DPDT).
- Contact Rating:**
2 amps resistive @ 30Vdc
300mA resistive @ 115 Vrms, 400 Hz.

Outline Dimensions

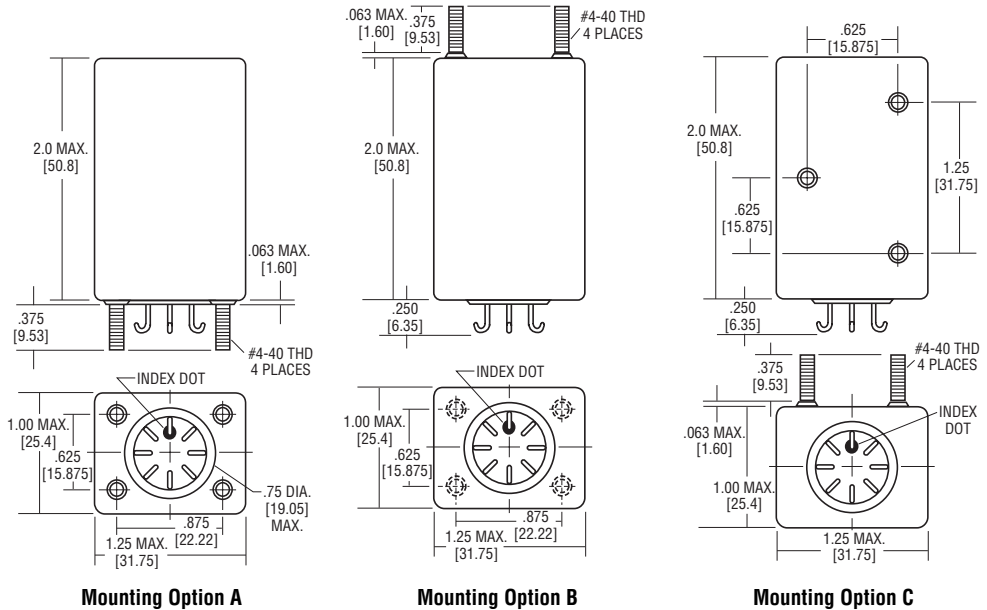

Environmental Specifications

- Temperature Range:** -55°C to +125°C.
- Vibration:** 20 G's, 10 - 2,000 Hz.
- Shock:** 50 G's, 11 ± 1ms duration.
- Insulation Resistance:** 1,000 megohms, min., at 500Vdc, all terminals to case.
- Dielectric Strength:** 1,000Vrms, 60 Hz., at sea level, all terminals to case.
- Sealing:** Hermetic, 1.3 in. (33.0mm) of mercury.
- Life:** 100,000 operations, min.
- Weight:** 3.5 oz (99.2g) max.

Wiring Diagram

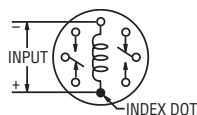

Part Numbering System

Typical Part Number	1310	- 2	A	- 24.5
Series:	1310 = DC Voltage Level Sensor, Relay Output			
Contact Form:	2 = 2 Form C (DPDT)			
Mounting (see outline dimension drawings):	A = Studs on bottom B = Studs on top C = Studs on side			
Pull-In Voltage:	Specify any level between 10 and 150Vdc			

© 2006 by Tyco Electronics Corporation. All Rights Reserved.
CII and TYCO are trademarks.
Other products and company names mentioned herein may be trademarks of their respective owners.



07

**TWO POLE 10 AMP
HIGH-PERFORMANCE RELAY**

**QUALIFIED TO MIL-R-5757/23
MS 27245 & MS 27247**

FEATURES

- Hermetically sealed
- Up to 10 amps switching
- High shock & vibration ratings
- Optional terminals & mounting styles
- DC, AC & diode-suppressed coils

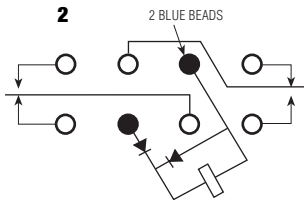

TERMINAL VIEW

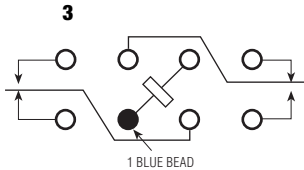

TERMINAL VIEW

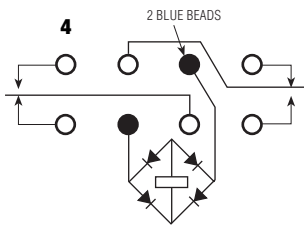

TERMINAL VIEW

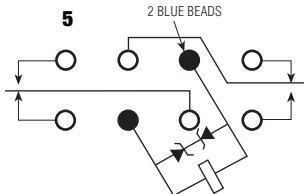

TERMINAL VIEW

ELECTRICAL CHARACTERISTICS

CONTACT ARRANGEMENT

2 Form C (DPDT)

CONTACT MATERIAL

Stationary: Silver cadmium oxide
Moveable: Silver cadmium oxide

CONTACT RESISTANCE

Before Life: 10 milliohms max.
After life: 20 milliohms max.
(Measured at 10 A @ 28 Vdc)

MECHANICAL LIFE EXPECTANCY

1 million operations

COIL VOLTAGE

6 to 120 Vdc,
115 Vac

COIL POWER

4.3 watts max. @ 25°C

DUTY CYCLE

Continuous

PICK-UP VOLTAGE

Approximately 50% of
nominal coil voltage

PICK-UP SENSITIVITY

565 mW

CONTACT RATINGS*

CONTACT LOAD	TYPE	OPERATIONS MIN.
10 A @ 28 Vdc	Resistive	100,000
3 A @ 115 V, 60 Hz	Resistive	50,000
5 A @ 115 V, 400 Hz	Resistive	50,000
6 A @ 28 Vdc	Inductive	50,000
2 A @ 115 V, 60 Hz	Inductive	50,000
2.5 A @ 115 V, 400 Hz	Inductive	50,000
1 A @ 28 Vdc	Lamp	50,000
0.5 A @ 115 V, 60 Hz	Lamp	50,000
0.8 A @ 115 V, 400 Hz	Lamp	50,000
3 A @ 28 Vdc	Motor	50,000
1.5 A @ 115 V, 60 Hz	Motor	50,000
3 A @ 115 V, 400 Hz	Motor	50,000

*All ratings grounded case

OPERATING CHARACTERISTICS

TIMING

Operate time:
Std: 10 ms max.
QPL: 15 ms max.
AC Coil: 15 ms max.

Release Time:
Std: 10 ms max.
QPL: 15 ms max.
AC Coil: 20 ms max.

CONTACT BOUNCE

Std: 5 ms max. (N.O. and N.C.)
QPL: 2 ms max. (N.O.)
QPL: 5 ms max. (N.C.)

DIELECTRIC WITHSTANDING VOLTAGE

Between Open Contacts:
500 Vrms 60 Hz

Between Adjacent Contacts:
1000 Vrms 60 Hz

Between Contacts and Coil:
1000 Vrms 60 Hz

INSULATION RESISTANCE

1,000 megohms min. @ 500 Vdc

ENVIRONMENTAL CHARACTERISTICS

TEMPERATURE RANGE

-65°C TO +125°C

WEIGHT

1.3 oz (37 gms) max.

VIBRATION RESISTANCE

Standard: 30 G's, 10 to 2,000 Hz
QPL: 20 G's, 10 to 2,000 Hz

SHOCK RESISTANCE

100 G's, 6 ± 1 ms

QPL APPROVAL

MIL-R-5757/23
MS 27245
MS 27247

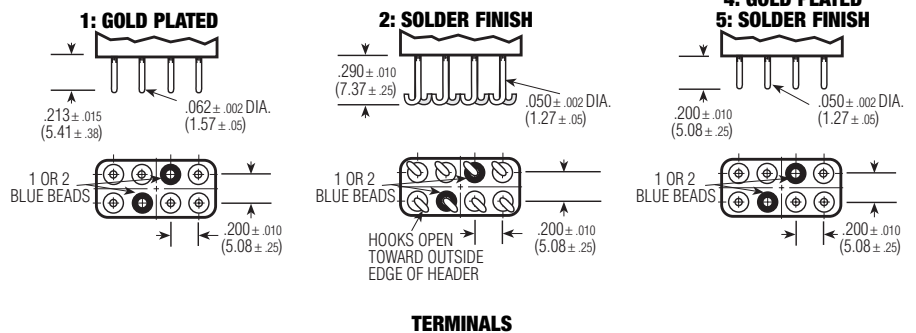

COIL DATA

NOM. COIL VOLTAGE (Vdc)	COIL RESISTANCE IN OHMS ±10% @ 25°C	PICKUP VOLTAGE Vdc (MAX.) @ 25°C	PICKUP VOLTAGE Vdc (MAX.) @ 125°C	DROPOUT VOLTAGE Vdc (MIN.) @ 25°C	DROPOUT VOLTAGE Vdc (MIN.) @ -65°C	NOM. COIL POWER (mW) @ 25°C	MAX. COIL VOLTAGE	COIL DESIG.	ENVIRONMENTAL
6.0	19	3.6	4.5	0.4	0.25	1.89	9.0	AA	TEMPERATURE
12.0	75	7.2	9.0	0.9	0.5	1.92	16.0	AB	-55°C to +85°C
26.5	300	14.4	18.0	1.8	1.0	2.34	32.0	AC	VIBRATION
48.0	1,200	29.0	36.0	3.6	2.0	1.92	52.0	AD	20G's, 10 to 2,000Hz
120.0	7,600	72.0	90.0	9.0	5.0	1.89	122.0	AE	SHOCK
115 Vac 400 Hz	1,200	72.0	90.0	10.0	5.0	n/a	n/a	AR	50G's, 11ms
115 Vac 60-400 Hz	7,600	72.0	90.0	10.0	5.0	n/a	n/a	AS	
6.0	19	3.3	4.5	0.4	0.25	1.89	9.0	BA	TEMPERATURE
12.0	75	6.5	9.0	0.9	0.5	1.92	16.0	BB	-65°C to +125°C
26.5	300	13.0	18.0	1.8	1.0	2.34	32.0	BC	VIBRATION
48.0	1,200	26.0	36.0	3.6	2.0	1.92	52.0	BD	20G's, 10 to 2,000Hz
120.0	7,600	66.0	90.0	9.0	5.0	1.89	122.0	BE	SHOCK
115 Vac 400 Hz	1,200	75.0	90.0	10.0	5.0	n/a	n/a	BR	50G's, 11ms
115 Vac 60-400 Hz	7,600	75.0	90.0	10.0	5.0	n/a	n/a	BS	
6.0	19	3.7	5.0	0.4	0.25	1.89	9.0	CA	TEMPERATURE
12.0	75	7.4	10.0	0.9	0.5	1.92	16.0	CB	-65°C to +125°C
26.5	300	14.7	20.0	1.8	1.0	2.34	32.0	CC	VIBRATION
48.0	1,200	29.4	40.0	3.6	2.0	1.92	52.0	CD	30G's, 10 to 2,000Hz
120.0	7,600	74.0	100.0	9.0	5.0	1.89	122.0	CE	SHOCK
115 Vac 400 Hz	1,200	80.0	100.0	10.0	5.0	n/a	n/a	CR	100G's, 6ms
115 Vac 60-400 Hz	7,600	80.0	100.0	10.0	5.0	n/a	n/a	CS	

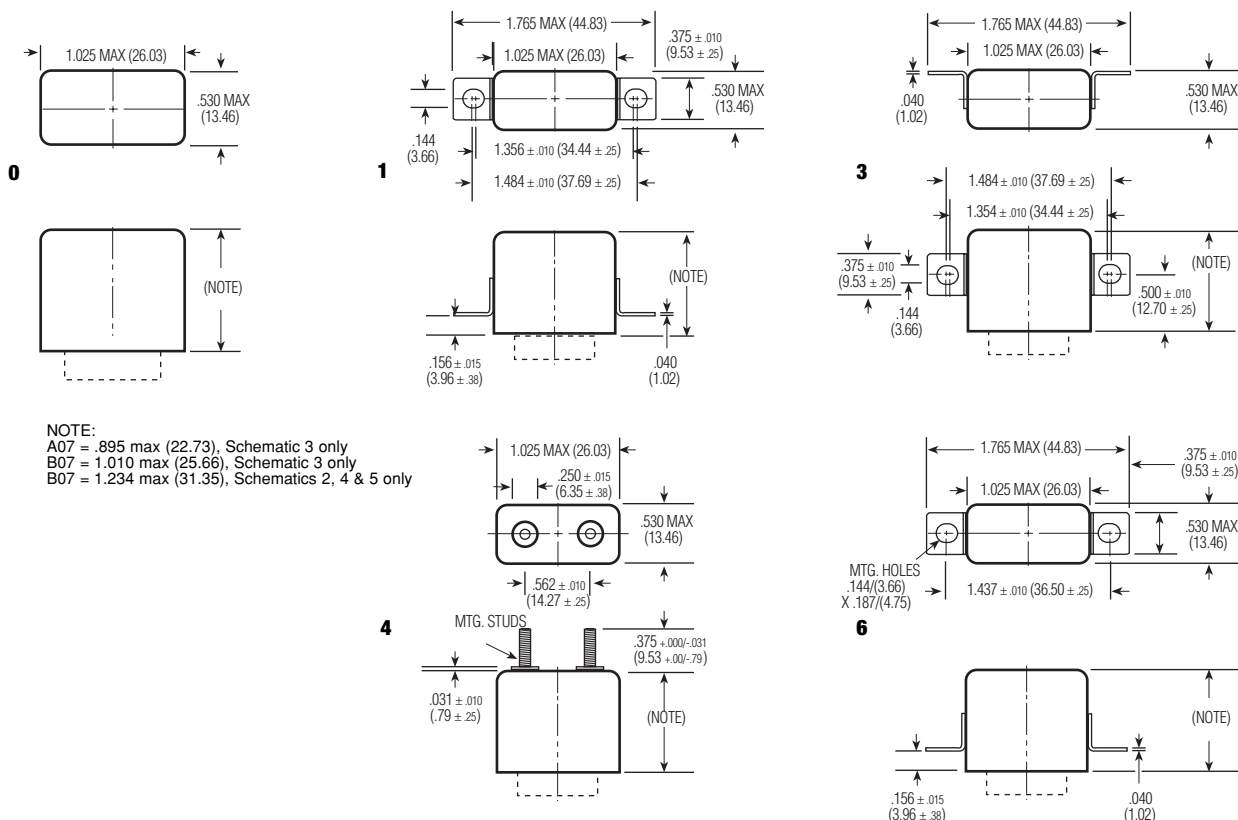

07 MOUNTING STYLES

SPECIFYING A PART NUMBER EXAMPLE:

TYPE	RATINGS	MOUNTINGS	SCHEMATIC	TERMINALS	COIL	TESTING
B07	B	3	3	2	BC	1

Long-life Half-size Industrial Relay

Code Location Guide

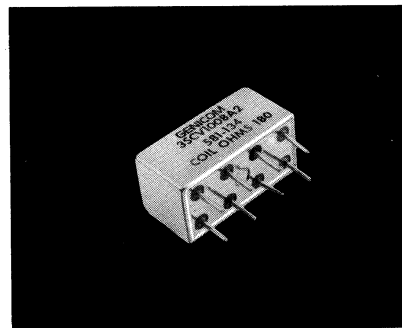

Type 3SCV (2PDT)

Other Specifications

Features

- 100,000,000 operations at low-level
- Hermetic seal

Description

The 3SCV is an exceptionally long life relay for low level applications which is designed for industrial applications such as business machines and computer peripheral equipment. The design is such that the phenomenon of sticking contacts is all but eliminated. Because of its low contact resistance and its ability to handle overloads the 3SCV relay is ideally suited for applications which have previously required reed devices.

- Contacts:**
2 Form C
- Contact Resistance:**
0.050 ohms;
0.100 ohms after life test
- Life:**
10⁸-2A 28 volts DC,
115 volts AC (not grounded, resistive)
.5A
Low-level— 100,000,000 operations
— 50 μ A at 50 mV Peak AC or DC
- Sensitivity:**
340 mW
- Operate Time:**
6 ms max.
- Release Time:**
4 ms max.
- Bounce Time:**
2 ms max.

- Enclosure:**
All welded, hermetically sealed
- Terminals:**
Weldable and solderable
- Weight:**
.30 oz.
- Dielectric Strength:**
500 volts rms at sea level
- Insulation Resistance:**
1,000 megohm min.
- Vibration:**
10G, 10-2000 Hz
- Shock:**
50 G 6ms; 1/2 sine
- Temperature:**
-14C to +125C

See page 26 for Mounting Forms, Terminals and Circuit Diagrams.

Coil Table (All Values DC)* 340 mW Sensitivity: (Code 1)

Coil Code Letter	Coil Resistance at 25C (ohms)	Voltage Calibrated, CODE: 5			
		Suggested Source Volts†	Maximum Operate Volts at 25C	Release Voltage Range at 25C	
				Max	Min
A	47 ± 10%	4.8-7	3.9	2.7	.43
B	75 ± 10%	6.1-9	4.9	3.4	.5
C	120 ± 10%	7.7-12	6.3	4.4	.69
D	180 ± 10%	9.5-15	7.7	5.4	.85
E	310 ± 10%	12.5-20	10.1	7.0	1.1
F	440 ± 10%	15.0-23	12.0	8.4	1.3
H	700 ± 10%	20.0-30	15.5	10.9	1.7
K	1030 ± 10%	24.0-35	18.5	12.9	2.0
L	1620 ± 10%	30.0-44	23.1	16.2	2.5
M	2640 ± 10%	39.0-56	29.5	20.68	3.2

ORDERING INSTRUCTIONS

Catalog-selected Relays: The catalog number is derived by choosing the proper CODE for each of the six relay characteristics in the order in which the codes are listed. Use the location guide (letters in vertical red columns) to find each CODE easily.

Example: The relay selected in this example is a 2PDT half-size relay, voltage calibrated, two-hole side bracket mounting, solder hook header, 700 ohms coil resistance, and 100 mW sensitivity. By choosing the proper code for each of these relay characteristics, the catalog number is identified as 3SAV5042H2. The letter R following sensitivity code indicates relay received 5000 operation miss-test. Ex. 3SAV5042H2R.

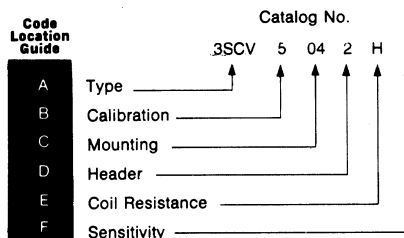

A

F

B

E



Mounting Forms (3SCV)

No Mount

Mounting Code
00

* Assumes relay held securely by potting or other means.

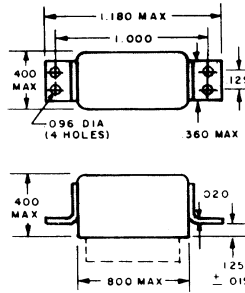
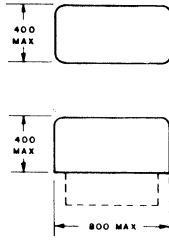

All dimensions in inches

TOLERANCES	
(Unless otherwise specified) Hundredths	±0.020
Thousandths	±0.005

Four-hole End Bracket

Mounting Code
01

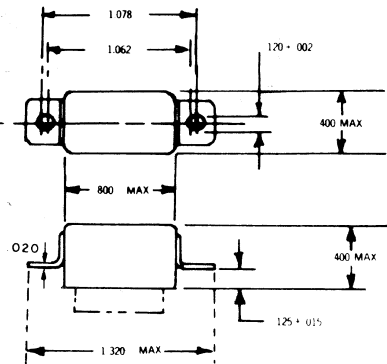

Two-hole elliptical END bracket

Mounting Code
53

Two-hole elliptical Side Bracket

Mounting Code
54

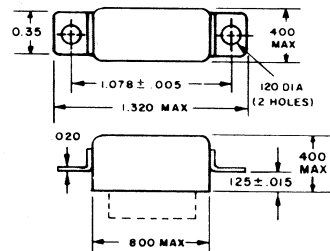
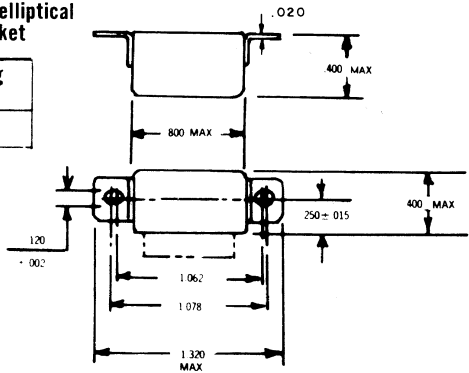

Two-hole End Bracket

Mounting Code
13

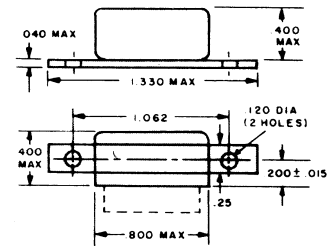

Two-hole Side Bracket

Mounting Code
04

Header and Connection Diagrams

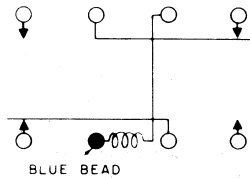
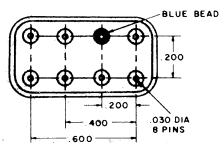

Header Types

Type	Z Dim.	Header Code
Solder hook	0.16	2
Straight pin (socket or PCB type)	0.19	4

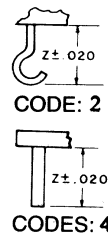



150 Grid-space Relays Magnetic-latching

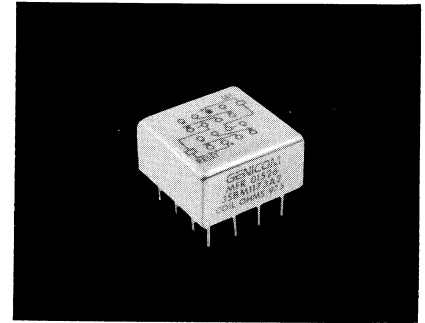

Type 3SBM (4PDT)

Other Specifications

Features

- Low profile... only 0.32 inch high
- Internal diode for coil transient suppression available
- MIL-R-39016/31, 35, 36
- Suitable for pulse operation—2 ms at rated voltage

Description

The Type 3SBM relay adds magnetic-latching capability to the popular and growing family of 150-grid relays. This relay has memory in that the contact positions do not change when coil power is removed. Switching is accomplished by applying power to the applicable coil (dual coil) or with the applicable polarity (single coil). The low switching power requirements are further enhanced by its ability to operate from capacitor discharge or other pulses or through its own contacts from batteries or similarly limited supplies.

Contact Arrangement:

4-pole double-throw (4C)

Operate Sensitivity:

Single-coil form, 100 mW, dual-coil form, 180 mW

Contact Ratings:

DC resistive—2 amps at 28 volts
DC inductive—0.5 amps at 28 volts, 200 mH

AC resistive—0.5 amps at 115 volts (enclosure isolated from ground, or enclosure and movable contact at same potential)

AC 0.125 amps at 115 volts (enclosure at line potential with respect to movable contact)

Low-level—50 μ A at 50 mV
Peak AC or DC

Contact Resistance:

0.050 ohms max.;
0.150 ohms after life tests

Life:

100,000 operations at rated loads listed;
1,000,000, operations at low-level loads

Operate Time:

4 ms max.

Reset Time:

4 ms max.

Bounce:

1.5 ms

Dielectric Strength:

500 volts rms at sea level;
350 volts rms at 70,000 feet and above

Insulation Resistance:

1,000 megohms minimum over temperature range

Vibration:

30G, 55-3000 Hz

Shock:

150G at 11 ms

Temperature:

– 65C to +125C

See page 22 for Mounting Forms, Terminals and Circuit Diagrams.

Coil Table (All Values DC)*

Coil Code Letter	SINGLE COIL, SENSITIVITY 1, (100 mW)				Suggested Source Volts†	Coil Code Letter	DUAL COIL, SENSITIVITY CODE 2, (180 mW)			
	Coil Resistance @ 25C (Ohms) \pm 10%	Maximum Set-Reset Values		Suggested Source Volts†			Coil Resistance @ 25C (Ohms) \pm 10%	Maximum Set-Reset Values		Suggested Source Volts†
		Calibration Code 5 Voltage (Volts)	Calibration Code 6 Current (mA)					Calibration Code 5 Voltage (Volts)	Calibration Code 6 Current (mA)	
N	57	2.4	42	3.6– 8.5	H	10	1.4	135	2.0– 3.7	
R	256	5.1	20	7.6–18	N	37	2.6	70	3.8– 7.2	
T	830	9.1	11	14–32	R	145	5.2	35	7.6–14.5	
V	1700	13.0	7.7	20–46	T	450	9.0	20	14–25	
W	3250	18.0	5.5	28–63	V	975	13.5	13.5	20–35	
					W	2140	20.0	9.2	30–54	

* Values are factory test and inspection values. User should allow for meter variations.
† Applicable over the operating temperature range in circulating air.

ORDERING INSTRUCTIONS

Type 3SBM relays can be ordered by specifying the correct catalog number. This number is derived by choosing the proper CODE for each of the six relay characteristics in the order in which the codes are listed. Use the code location guide (letters in vertical red columns) to find each CODE easily.

Example: The relay selected in this example is a dual-coil, current calibrated, four-hole end bracket mounting, solder hook header, 37 ohms coil resistance, and 180 mW sensitivity. By choosing the proper code for each of these relay characteristics, the catalog number is identified as 3SBM6131N2. The letter R following sensitivity code indicates relay received 5000 operations miss-test. Ex. 3SBM6131N2R.

Code Location Guide

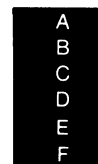

Relay Characteristic Catalog No.

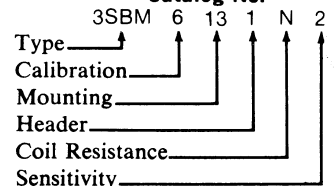



150 Grid-space Relays Hybrid Magnetic-latching Single Diode, Dual Diode

Code
Location
Guide

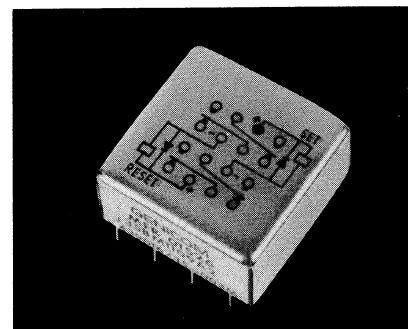

Type 3SBM (4PDT)

Features

- Low profile... only 0.32 inch high
- Suitable for pulse operation
- MIL-R-39016/35
- MIL-R-39016/36

Description

The dual coil version of the 3SBM magnetic latching relay is now available with coil transient suppression with or without blocking diodes for reverse polarity protection. This hybrid magnetic latching relay is an addition to the growing family of 150 grid relays. The diode method is employed to limit the back EMF generated when the coil circuit is opened in order to protect other circuit components such as semiconductors. The contact load capabilities of the 3SBM as well as the memory feature of the latching function are both maintained.

Semiconductor

Characteristics at 25C:

Max. Negative Transient: 1 volt
Breakdown voltage: 100VDC Minimum
Max. Leakage Current: 1 microamp 50VDC

Other Specifications

Contact Arrangement:

4-pole double-throw (4C)

Operate Sensitivity:

Single-coil form, 100 mW, dual-coil form, 180 mW per coil

Contact Ratings:

DC resistive—2 amps at 28 volts
DC inductive—0.5 amps at 28 volts, 200 mH
AC resistive—0.5 amps at 115 volts (enclosure isolated from ground, or enclosure and movable contact at same potential)
AC 0.125 amps at 115 volts (enclosure at line potential with respect to movable contact)
Low-level—50 μ A at 50 mV
Peak AC or DC

Contact Resistance:

0.050 ohms max.;
0.150 ohms after life test

Life:

100,000 operations at rated loads listed;
1,000,000, operations at low-level loads

Operate Time:

4 ms max.

Reset Time:

4 ms max.

Bounce:

1.5 ms

Dielectric Strength: Note (1)

500 volts rms at sea level;
350 volts rms at 70,000 feet and above

Insulation Resistance: Note (1)

1,000 megohms minimum over temperature range

Vibration:

30G, 55-3000 Hz

Shock:

150G at 11 ms

Temperature:

– 65C to +125C

Note (1): Tests for dielectric withstanding voltage and insulation resistance should be made with "coil terminals" shorted together to avoid unnecessary electrical stress to semiconductor elements.

See page 22 for Mounting Forms, Terminals and Circuit Diagrams.

Coil Table Single Diode (All Values DC)*

Coil Code Letter	Dual Coil, Sensitivity Code 5 (180 mW)			
	Coil Resistance @ 25C (ohms) \pm 10%	MAX. SET—RESET VALUES		Suggested Source Volts†
		Calibration Code 5 Voltage (Volts)	Calibration Code 6 Current (mA)	
H	10	1.4	135	2.0- 3.7
N	37	2.6	70	3.8- 7.2
R	145	5.2	35	7.6-14.5
T	450	9.0	20	14-25
V	975	13.5	3.5	20-35
W	2140	20.0	9.2	30-54

Coil Table Dual Diode (All Values DC)*

Coil Code Letter	Dual Coil, Sensitivity Code 6 (180 mW)			
	Coil Resistance @ 25C (ohms) \pm 10%**	MAX. SET—RESET VALUES		Suggested Source Volts†
		Calibration Code 5 Voltage (Volts)	Calibration Code 6 Current (mA)	
H	10	2.4	135	2.6- 4.1
N	37	3.6	70	3.8- 7.2
R	145	6.2	35	7.6-14.5
T	450	10.0	20	14.0-25.0
V	975	14.5	13.5	20.0-35.0
W	2140	21.0	9.2	30.0-45.0

* Values are factory test and inspection values. User should allow for meter variations.

† Applicable over the operating temperature range in circulating air.

**Coil resistance cannot be measured by conventional bridge.

A

F
B

E



Mounting Forms (3SBM)

(Vibration note with each form is acceleration from 55 to 3000 Hz).

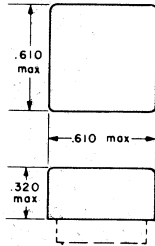

No Mount

Mounting Code	Vibration*
00	30g

*Assumes relay held securely by potting or other means.

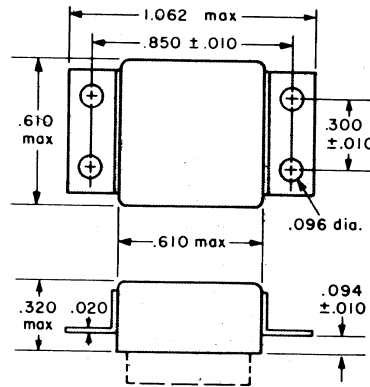

End Bracket

Mounting Code	Vibration
13	30g

ALL DIMENSIONS IN INCHES

TOLERANCES
Unless otherwise specified:

Hundredths	±0.020
Thousandths	±0.005

Header and Connection Diagrams

DUAL COIL

When the SET coil is pulsed with plus polarity on the blue bead, the movable contacts take the position shown in the connection diagram. The contacts are transferred when the RESET coil is pulsed with plus polarity on the reset terminal. A new pulse of the SET coil with plus polarity on the blue bead will transfer the contacts back.

The contacts can also be transferred by applying a pulse of opposite polarity to the coil previously pulsed. However, this method requires slightly more power than the more normal form of operation described in the previous paragraph.

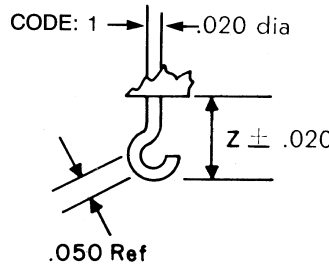

CODES: 4,5,8

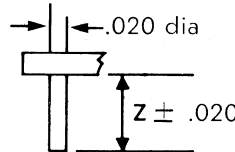

Header Types

Type	Z Dimension	Header Code
Solder Hook	0.13	1
Straight Pin	0.12	8
Straight Pin (socket or PCB type)	0.19	4
Straight Pin	0.25	5

Terminal numbers for reference only

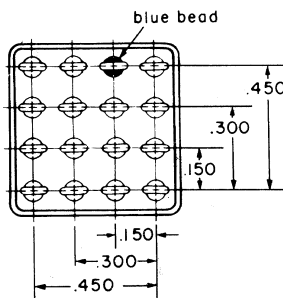

CODE 1

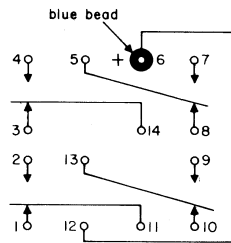

(Terminal numbers for reference only)

CODE 2

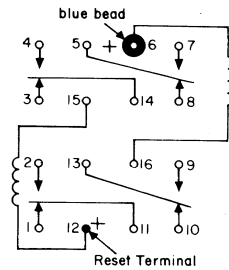

CODE 5
Single Diode

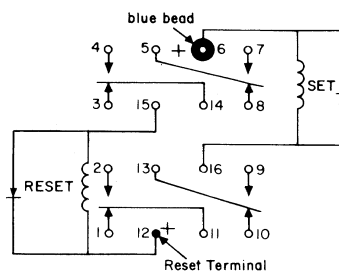

CODE 6
Dual Diode

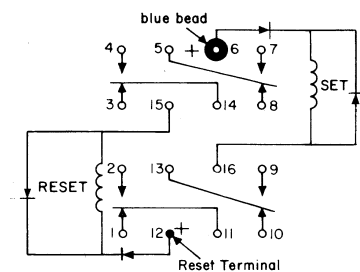



150 Grid-space Micro-miniature Relays

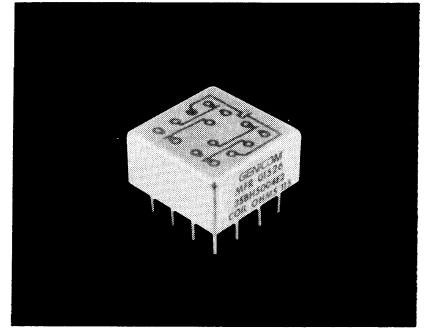

A

Type 3SBH (4PDT)

Features

- Low profile... only 0.32 inch high
- Long life version available
- MIL-R-39016/14

Description

This 150 four pole double throw Grid-space relay is the companion to the two pole 3SBC type shown on page 10. It also features the same .150 inch pin spacing that allows you to insert the relay with no intermediate pin spreaders. There is adequate clearance for conductors to reach all pins. It is a very compact 4 pole double throw 2 ampere relay.

Other Specifications

Contact Ratings:

DC resistive—2 amps at 28 volts
 DC inductive—0.5 amps at 28 volts, 200 mH
 AC resistive—0.5 amps at 115 volts, 400 or 60 Hz (enclosure isolated from ground, or enclosure and movable contact at same potential)
 AC 0.125 amps at 115 volts (enclosure at line potential with respect to movable contact)
 Low level—low-level operation at 50 millivolts, 30 microamps, 33-ohm miss level

Contact Resistance:

0.050 ohms max.; 0.150 ohms after life test

Life:

100,000 operations at rated loads listed; 1,000,000, operations at low-level loads

Operate Time:

4 ms max.

Release Time:

4 ms max.

Bounce:

1.5 millisecond

Dielectric Strength:

500 volts rms at sea level; 350 volts rms at 70,000 feet

Insulation Resistance:

1,000 megohms minimum over temperature range

Vibration:

30G, to 3000 Hz

Shock:

100G at 11 ms

Temperature:

– 65C to +125C

See page 19 for Mounting Forms, Terminals and Circuit Diagrams.

F B

Coil Table (All Values DC)* Type 3SBH, 4 Pole Relay — 250 mW Sensitivity: (Code 1)

SENSITIVITY CODE: 1					
Coil Code Letter	Coil Resistance at 25C ohms	Voltage Calibrated, Code: 5			
		Suggested Source Volts†	Maximum Operate Volts at 25C	Release Voltage Range at 25C	
				Max.	Min.
B	28 ± 10%	4.0- 7.0	2.7	1.6	0.3
D	73 ± 10%	6.0-11.0	4.2	2.5	0.4
E	115 ± 10%	8.0-14.0	5.4	3.2	0.6
G	280 ± 10%	12 -22.0	8.4	5.0	0.8
H	430 ± 10%	15 -26.0	10.3	6.0	1.0
K	720 ± 10%	20 -35.0	13.5	8.1	1.5
N	1040 ± 10%	26 -46.0	17.5	10.5	1.9

* Values listed are Factory test and inspection values. User should allow for meter variations. † Applicable over the operating temperature range in circulating air.

E

ORDERING INSTRUCTIONS

Catalog-selected Relays: The catalog number is derived by choosing the proper CODE for each of the six relay characteristics in the order in which the codes are listed. Use the location guide (letters in vertical red columns) to find each CODE easily.

Example: The relay selected in this example is a 4PDT 150-grid relay, voltage calibrated end bracket mounting, 0.13-inch solder hook header, 720 ohms coil resistance, and 250 mW sensitivity. By choosing the proper code for each of these relay characteristics, the catalog number is identified as 35BH5131K5. The letter R following sensitivity code indicates relay received 5000 operation miss-test. Ex. 35BH5131K5R

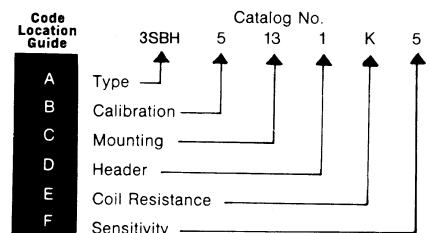

150 Grid-space Hybrid Micro-miniature Relays

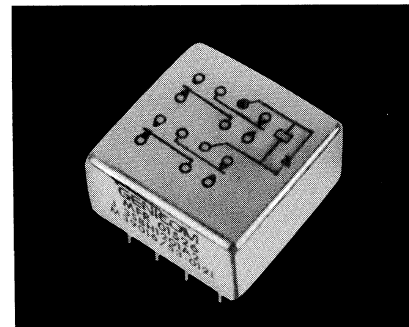

Type 3SBH (4PDT)

Features

- Low profile... only 0.32 inch high
- Long life version available
- MIL-R-39016/53 & 54

Description

The 4PDT .150 Grid-space hybrid relays are advanced designs of the standard high reliability 4PDT .150 Grid-space relays. In the single diode version, the relay coil-back electromotive force is suppressed to prevent circuit/component damage. With the dual diode version, a steering diode is added to the coil circuit, along with the suppression diode. This steering diode prevents operation of the relay by reverse polarity voltages and protects the suppression diode. The single diode version is qualified to MIL-R-39016/53 and the dual diode is qualified to MIL-R-39016/54.

Other Specifications

Contact Ratings:

DC resistive—2 amps at 28 volts
 DC inductive—0.5 amps at 28 volts, 200 mH
 AC resistive—0.5 amps at 115 volts, 400 or 60 Hz (enclosure isolated from ground, or enclosure and movable contact at same potential)
 AC 0.125 amps at 115 volts (enclosure at line potential with respect to movable contact)
 Low-level—50 μ A at 50 mV
 Peak AC or DC

Contact Resistance:

0.050 ohms max.;
 0.150 ohms after life test

Life:

100,000 operations at rated loads listed;
 1,000,000, operations at low-level loads

Operate Time:

4 ms max.

Release Time:

6 ms max.

Bounce:

2.0 millisecond

Dielectric Strength: Note (1)

500 volts rms at sea level;
 350 volts rms at 70,000 feet

Insulation Resistance: Note (1)

1,000 megohms minimum over temperature range

Semiconductor Characteristics at 25C:

Max. Negative Transient: 1 volt
 Breakdown voltage: 100VDC @ 10 μ A Minimum
 Max. Leakage Current: 1 microamp @ 50VDC

Note (1): Tests for dielectric withstanding voltage and insulation resistance should be made with "coil terminals" shorted together to avoid unnecessary electrical stress to semiconductor elements.

See page 19 for Mounting Forms, Terminals and Circuit Diagrams.

Coil Table (All Values DC)* Type 3SBH, 4 Pole Relay — 250 mW Sensitivity: (Code 5 single diode, Code 6 dual diodes)

Single Diode		SENSITIVITY CODE: 5			
Coil Code Letter	Coil Resistance at 25C ohms	Voltage Calibrated, Code: 5			
		Suggested Source Volts†	Maximum Operate Volts at 25C	Release Voltage Range at 25C	
				Max.	Min.
B	28 \pm 10%	4.0- 7.0	2.7	1.6	0.3
D	73 \pm 10%	6.0-11.0	4.2	2.5	0.4
E	115 \pm 10%	8.0-14.0	5.4	3.2	0.6
G	280 \pm 10%	12 -22.0	8.4	5.0	0.8
H	430 \pm 10%	15 -26.0	10.3	6.0	1.0
K	720 \pm 10%	20 -35.0	13.5	8.1	1.5
N	1040 \pm 10%	26 -46.0	17.5	10.5	1.9
Dual Diode		SENSITIVITY CODE: 6			
B	28 \pm 10%	4.0- 7.0	3.7	2.3	0.5
D	73 \pm 10%	6.0-11.0	5.2	3.2	0.6
E	115 \pm 10%	8.0-14.0	6.4	3.9	0.8
G	280 \pm 10%	12.0-22.0	9.4	5.7	1.0
H	430 \pm 10%	15 -26.0	11.3	6.7	1.2
K	720 \pm 10%	20 -35.0	14.5	8.8	1.7
N	1040 \pm 10%	26 -46.0	18.1	11.1	2.1

*Values listed are factory test and inspection values. User should allow for meter variations.

†Applicable over the operating temperature range in circulating air.



Long-life 150 Grid-space Micro-miniature Relays

100,000,000 Operations At Low Levels

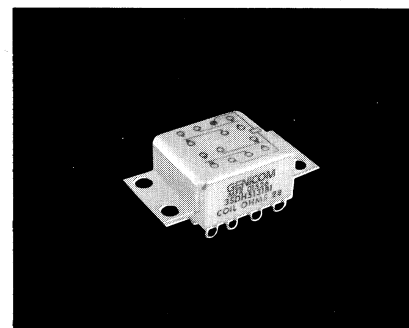

A

Type 3SDH (4PDT)

Features

- Long life at low level or signal loads.
- Low profile... only 0.32 inch high

Description

The 3SDH relay is designed for 100,000,000 operations at low levels. It is a four pole double throw Grid-spaced relay. The 0.150 inch pin spacing allows the user to insert the relay with no intermediate pin spreaders. There is adequate clearance for conductor to reach all pins.

Other Specifications

Contact Ratings:

DC resistive—2 amps at 28 volts, (DC 100,000 operations)
 DC inductive—0.3 amp at 28 volts, (L/R not greater than 0.008)
 AC resistive—0.5 amp at 115 volts, 400 or 60 Hz (enclosure isolated from ground, or enclosure and movable contact at same potential)
 AC resistive 0.125 amps at 115 volts (enclosure at line potential with respect to movable contact)
 Low-level—50 μ A at 50 mV
 Peak AC or DC

Contact Resistance:

0.050 ohms max.; 0.150 ohms after life tests

Life:

100,000 operations at rated loads lifted;
 100,000,000 operations @ low-level loads

Operate Time: @ +25°C
 4 ms max.

Release Time: @ + 25°C
 4 ms max.

Bounce: @ +25°C
 1.5 millisecond

Dielectric Strength:
 500 volts rms at sea level;
 350 volts rms at 70,000 feet

Insulation Resistance:
 1,000 megohms minimum over temperature range

Vibration:
 30G, to 3000 Hz

Shock:
 100G at 11 ms

Temperature:
 - 40C to +125C

See page 19 for Mounting Forms, Terminals and Circuit Diagrams.

F

B

E

Coil Table (All Values DC)*Type 3SDH, 4 Pole Relay—210mW Sensitivity: (Code 1)

SENSITIVITY CODE: 1					
Coil Code Letter	Coil Resistance at 25C ohms	Voltage Calibrated, Code: 5			
		Suggested Source Volts†	Maximum Operate Volts at 25C	Release Voltage Range at 25C	
				Max.	Min.
B	28 ± 10%	4.0- 7.0	3.0	1.6	0.3
D	73 ± 10%	6.0-11.0	4.8	2.5	0.4
E	115 ± 10%	8.0-14.0	5.9	3.2	0.6
G	280 ± 10%	12 -22.0	9.3	5.0	0.8
H	430 ± 10%	15 -26.0	11.5	6.0	1.0
K	720 ± 10%	20 -35.0	14.9	8.1	1.5
N	1040 ± 10%	26 -46.0	17.9	10.5	1.9

* Values listed are Factory test and inspection values. User should allow for meter variations. † Applicable over the operating temperature range in circulating air.

Mounting Forms (3SBH, 3SDH)

(Vibration note with each form is acceleration from 55 to 3000 Hz)

No Mount

Mounting Code	Vibration*
00	30g

*Assumes relay held securely by potting or other means.

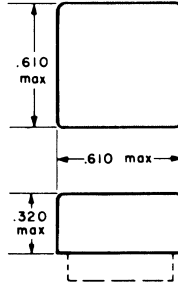

End Bracket

Mounting Code	Vibration
13	30g

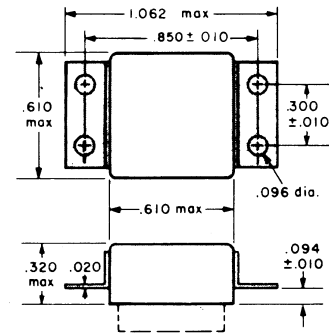

Header Types

Type	Z Dimension	Header Code
Solder hook	0.13	1
Straight pin	0.12	8
Straight pin socket or PCB type	0.19	4
Straight pin	0.25	5

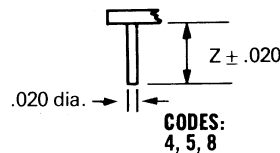
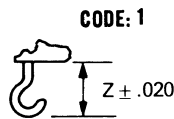

All dimensions in inches

TOLERANCES (Unless otherwise specified)	
Hundredths	±0.020
Thousandths	±0.005

Header and Connection Diagrams

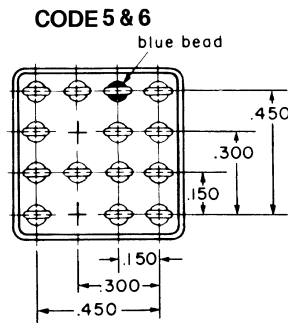
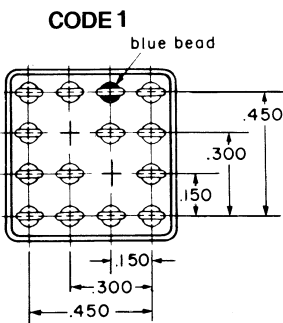
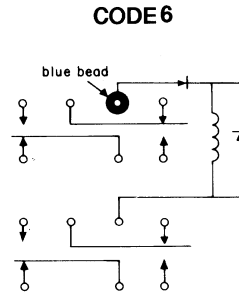
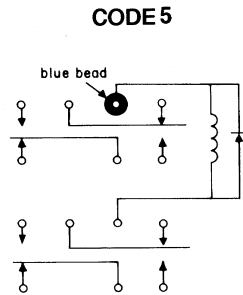
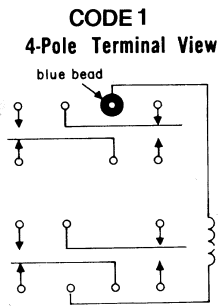

Terminals .020 dia

ORDERING INSTRUCTIONS

Catalog-selected Relays: The catalog number is derived by choosing the proper CODE for each of the six relay characteristics in the order in which the codes are listed. Use the location guide (letters in vertical red columns) to find each CODE easily.

Example: The relay selected in this example is a 4PDT 150-grid relay, voltage calibrated end bracket mounting, 0.13-inch solder hook header, 720 ohms coil resistance, and 250 mW sensitivity. By choosing the proper code for each of these relay characteristics, the catalog number is identified as 35BH5131K5. The letter R following sensitivity code indicates relay received 5000 operation miss-test. Ex. 35BH5131K5R

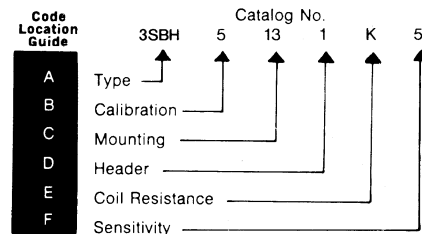

C

D

F



150 Grid-space Micro-miniature Relays

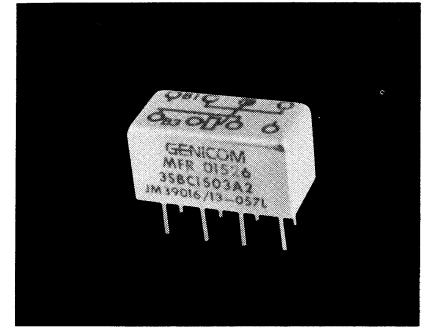

A

Type 3SBC (2PDT) Standard

135mW 2PDT
50 mW (Form AB) 1 PNC — 1 PNO

Features

- Low profile... only 0.32 inch high
- Internal diode for coil transient suppression and transistor driven models available
- MIL-R-39016/13
- RF designs available

Description

The 150 Grid-space relay — only 0.32 inches high — save space in electronic packaging. The pin spacing allows you to insert the relay with no intermediate pin spreaders as well as meet applicable military specifications.

Other Specifications

Contact Ratings:

DC resistive — 2 amps at 28 volts (50,000 operations)
1 Amp@ 28V (100,000 operations)
DC inductive — 0.5 amps at 28 volts, 200 mH
AC resistive — 0.5 amps at 115 volts
AC - 0.125 amps at 115 volts (case grounded)
Low-level — 50 μ A at 50 mV
Peak AC or DC

Contact Resistance:

0.050 ohms max.; 0.150 ohm after life test

Life:

100,000 operations at rated loads listed;
1,000,000 operations at low-level loads

Operate Time:

4 ms max.

Release Time:

4 ms max.

Bounce:

1.5 millisecond

Dielectric Strength:

500 volts rms at sea level
350 volts rms at 70,000 feet and above

Insulation Resistance:

1,000 megohms minimum over temperature range

Vibration:

30G, to 3000 Hz

Shock:

100G at 11 ms

Temperature:

-65C to +125C

See page 15 for Mounting Forms, Terminals and Circuit Diagrams.

F

B

E

Coil Table Type 3SBC (All Values DC)*2PDT, 135 mW Sensitivity: (Code 1)

Coil Code Letter	Coil Resistance @ 25C (ohms)	Voltage Calibrated, Code 5				Current Calibrated, Code 6			
		Suggested Source Volts†	Max. Operate Volts @ 25C	Release Voltage Range @ 25C		Max. Continuous Current @ 125C (mA)	Max. Operate Current @ 25C (mA)	Release Current Range @ 25C (mA)	
				Max.	Min.			Max.	Min.
A	44 ± 10%	3.5-6.2	2.4	1.45	0.26	87.0	54.5	32.7	6.00
B	56 ± 10%	4.0-7.0	2.7	1.6	0.3	77.0	48.3	28.6	5.30
D	140 ± 10%	6.4-12.0	4.4	2.6	0.5	50.3	31.4	18.5	3.60
E	210 ± 10%	8.0-16.0	5.4	3.2	0.6	40.0	25.7	15.4	2.80
L	650 ± 10%	13.6-24.0	9.5	5.6	1.0	22.9	14.3	8.6	1.54
K	1350 ± 10%	20.0-35.0	13.5	8.1	1.5	15.5	10.0	6.0	1.10
N	2245 ± 10%	26.0-46.0	17.1	10.5	1.9	12.0	7.6	4.7	0.84

F

B

E

Coil-Data (All Values DC)* Type 3SBC Form AB 50 mW Sensitivity non mil spec: (Code 2)

Coil Code Letter	Coil Resistance @ 25C (ohms)	Voltage Calibrated, Code 5				Current Calibrated, Code 6			
		Suggested Source Volts†	Max. Operate Volts @ 25C	Release Voltage Range @ 25C		Max. Continuous Current @ 125C (mA)	Max. Operate Current @ 25C (mA)	Release Current Range @ 25C (mA)	
				Max.	Min.			Max.	Min.
B	56 ± 10%	2.6-7.0	1.8	1.1	0.16	46.5	29.1	18.2	3.30
C	85 ± 10%	3.3-9.5	2.3	1.4	0.20	38.7	24.2	15.1	2.70
D	140 ± 10%	4.3-12.0	2.9	1.8	0.27	30.4	19.0	11.9	2.10
E	210 ± 10%	5.3-14.0	3.6	2.2	0.33	24.8	15.5	9.7	1.75
F	360 ± 10%	6.7-19.0	4.5	2.8	0.41	18.9	11.8	7.2	1.30
G	510 ± 10%	8.2-23.0	5.6	3.5	0.51	15.8	9.9	6.2	1.10
H	775 ± 10%	10.0-26.0	6.8	4.2	0.62	12.8	8.0	5.0	0.90
K	1350 ± 10%	13.2-35.0	9.0	5.6	0.82	9.8	6.1	3.8	0.68
N	2245 ± 10%	16.8-46.0	11.4	7.1	1.00	7.4	4.6	2.9	0.52

*Values listed are factory test and inspection data. User should allow for meter variations.

†At nominal resistance plus 10%.

‡ Applicable over the operating temperature range in circulating air.

150 Grid-space Hybrid Micro-miniature Relays

Single Diode, Dual Diode

Type 3SBC (2PDT)
135 mW

Features

- Low profile... only 0.32 inch high
- 50 milliwatt forms available
- MIL-R-39016/37
- MIL-R-39016/38
- RF designs available

Description

The hybrid 150 Grid-space relay — only 0.32 inches high — saves space in electronic packaging. The pin spacing allows you to insert the relay with no intermediate pin spreader.

Other Specifications

Contact Ratings:

DC resistive — 2 amps at 28 volts (50,000 operations)
1 Amp@ 28V (100,000 operations)
DC inductive — 0.5 amps at 28 volts, 200 mH
AC resistive — 0.5 amps at 115 volts
AC - 0.125 amps at 115 volts (case grounded)
Low-level — 50 μ A at 50 mV
Peak AC or DC

Contact Resistance:

0.050 ohms max.; 0.150 ohm after life test

Life:

100,000 operations at rated loads listed;
1,000,000 operations at low-level loads.

Operate Time:

4 ms max.

Release Time:

6 ms max.

Bounce:

1.5 millisecond

Dielectric Strength: Note (1)

500 volts rms at sea level
350 volts rms at 70,000 feet and above

Insulation Resistance: Note (1)

1,000 megohms minimum over temperature range

Vibration:

30G, to 3000 Hz

Shock:

100G at 11 ms

Temperature:

-65C to +125C

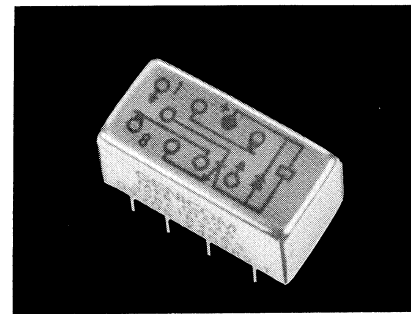

Semiconductor Characteristics at 25C

DIODE

Max. Negative Transient: 1.0 volt
Breakdown voltage: 100VDC @ 10 microamps
Max. Leakage Current: 1 micro amp @ 50 VDC

See page 15 for Mounting Forms, Terminals and Circuit Diagrams.

Coil Table Single Diode (All Values DC)*(2DPT), 135 mW Sensitivity: (Code 5)

Coil Code Letter	Coil Resistance @ 25C (ohms)	Voltage Calibrated, Code 5				Current Calibrated, Code 6			
		Suggested Source Volts†	Max. Operate Volts @ 25C	Release Voltage Range @ 25C		Max. Continuous Current @ 125C (mA)	Max. Operate Current @ 25C (mA)	Release Current Range @ 25C (mA)	
				Max.	Min.			Max.	Min.
A	44 ± 10%	3.5- 6.2	2.4	1.45	0.26	87.0	54.5	32.7	6.00
B	56 ± 10%	4.0- 7.0	2.7	1.6	0.3	77.0	48.3	28.6	5.30
D	140 ± 10%	6.4-12.0	4.4	2.6	0.5	50.3	31.4	18.5	3.60
E	210 ± 10%	8.0-16.0	5.4	3.2	0.6	40.0	25.7	15.4	2.80
L	650 ± 10%	13.6-24.0	9.5	5.6	1.0	22.9	14.3	8.6	1.54
K	1350 ± 10%	20.0-35.0	13.5	8.1	1.5	15.5	10.0	6.0	1.10
N	2245 ± 10%	26.0-46.0	17.1	10.5	1.9	12.0	7.6	4.7	0.84

Coil Table Dual Diode (All Values DC)*(2DPT), 135 mW Sensitivity: (Code 6)

Coil Code Letter	Coil Resistance @ 25C (ohms)	Suggested Source Volts†	Max. Operate Volts @ 25C	Release Voltage Range @ 25C (Max./Min.)	Max. Continuous Current @ 125C (mA)	Max. Operate Current @ 25C (mA)	Release Current Range @ 25C (mA) (Max./Min.)
A	44 ± 10%	3.9- 7.0	3.4	2.0 / 0.37	98.2	77.3	45.5 / 8.4
B	56 ± 10%	4.6- 8.0	3.7	2.2 / 0.41	89.8	66.1	39.3 / 7.1
D	140 ± 10%	7.8-12.0	5.4	3.2 / 0.6	52.4	38.6	22.9 / 4.3
E	210 ± 10%	9.3-16.0	6.4	3.8 / 0.7	41.4	30.5	18.1 / 3.3
L	650 ± 10%	15.0-24.0	10.5	6.2 / 1.1	23.6	16.2	9.5 / 1.7
K	1350 ± 10%	21.0-35.0	14.5	8.7 / 1.6	16.0	10.7	6.4 / 1.2
N	2245 ± 10%	27.0-46.0	18.1	10.9 / 2.0	12.1	8.1	4.9 / 0.9

ORDERING INSTRUCTIONS

Example: The relay selected in the example is a FORM AB 150-grid relay, current calibrated, end bracket mounting with 0.13-inch solder hook header, 210 ohms coil resistance, and 50 mW sensitivity. By choosing the proper code for each of these relay characteristics, the

catalog number is 3SBC6131E2. The letter R following sensitivity code indicates relay received 5000 operation miss-test. Ex. 3SBC6131E2R.

Note: Relays specified by catalog numbers (per above directions) are general-use items controlled by catalog specifications. Relays to be controlled by customer drawings — or relays having requirements not covered in this publication — will be assigned special catalog numbers upon request.

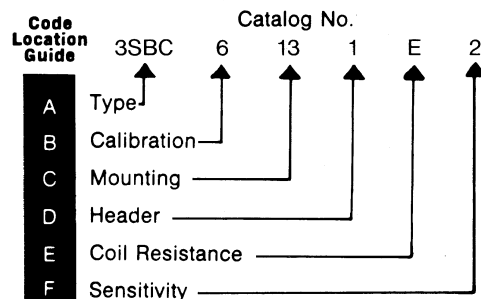

A

F B

E

F

E



150 Grid-space Long-life Micro-miniature Relays

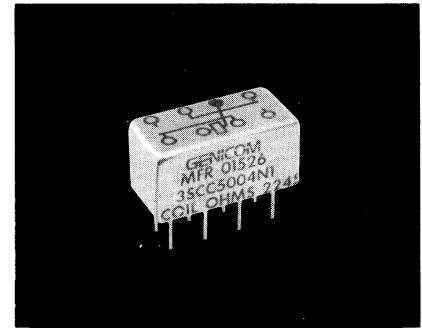

A

Type 3SCC (2PDT) 170 mW

Features

- 100,000,000 operations low-level signal loads
- RF designs available
- Low profile — .320 height
- Hermetic seal
- High reliability
- Performance tested

Description

The .150 Grid relay, the smallest (.320 inches high) 2 Amp Rated relay available in commercial and military qualified models, is now available in the long life version. Capable of over 100,000,000 mechanical operations at low level and signal load, the .150 Grid relay provides the simplicity of relays for circuit design, the low circuit resistance of precious metal

contact systems, and the long life processing that has made CII relays the standard for quality and reliability.

Other Specifications

Contact Ratings:

DC resistive — 2 amps at 28 volts (50,000 operations)
 1 Amp@ 28V (100,000 operations)
 DC inductive — 0.5 amps at 28 volts, 200 mH
 AC resistive — 0.5 amps at 115 volts
 AC - 0.125 amps at 115 volts (case grounded)
 Low-level — 50 μ A at 50 mV
 Peak AC or DC

Contact Resistance:

0.050 ohm max.; 0.150 ohms after life test

Life:

100,000 operations at rated loads listed;
 100,000,000 operations at low-level loads

Operate Time:

4 ms max.

Release Time:
4 ms max.

Bounce:
1.5 millisecond

Dielectric Strength:
500 volts rms at sea level
350 volts rms at 70,000 feet and above

Insulation Resistance:
1,000 megohms minimum over temperature range

Vibration:
30G, to 3000 Hz

Shock:
100G at 11 ms

Temperature:
- 40C to + 125C

See page 15 for Mounting Forms, Terminals and Circuit Diagrams.

F

B

E

Coil Table Type 3SCC (All Values DC)* 2 PDT Relay — 170mW Sensitivity: (Code 1)

Coil Code Letter	Coil Resistance @ 25C (ohms)	Voltage Calibrated, Code 5				Current Calibrated, Code 6			
		Suggested Source Volts†	Max. Operate Volts @25C	Release Voltage Range @ 25C		Max. Continuous Current @ 125C (mA)	Max. Operate Current @ 25C (mA)	Release Current Range @ 25C (mA)	
				Max.	Min.			Max.	Min.
A	44 ± 10%	3.5- 6.2	2.7	1.45	0.26	87.0	61.4	32.7	6.00
B	56 ± 10%	4.0- 7.0	3.1	1.6	0.3	77.0	55.4	28.6	5.30
D	140 ± 10%	6.4-12.0	4.9	2.6	0.5	50.3	35.0	18.5	3.60
E	210 ± 10%	8.0-16.0	5.9	3.2	0.6	40.0	28.0	15.4	2.80
L	650 ± 10%	13.6-24.0	10.5	5.6	1.0	22.9	16.2	8.6	1.54
K	1350 ± 10%	20.0-35.0	15.1	8.1	1.5	15.5	11.2	6.0	1.10
N	2245 ± 10%	26.0-46.0	19.5	10.5	1.9	12.0	8.7	4.7	0.84

* Values listed are factory test and inspection data. User should allow for meter variations.

† Applicable over the operating temperature range in circulating air.

ORDERING INSTRUCTIONS

Example: The relay selected in the example is a FORM AB 150-grid relay, current calibrated, end bracket mounting with 0.13-inch solder hook header, 210 ohms coil resistance, and 50 mW sensitivity. By choosing the proper code for each of these relay characteristics, the

catalog number is 3SBC6131E2. The letter R following sensitivity code indicates relay received 5000 operation miss-test. Ex. 3SBC6131E2R.

Note: Relays specified by catalog numbers (per above directions) are general-use items controlled by catalog specifications. Relays to be controlled by customer drawings — or relays having requirements not covered in this publication — will be assigned special catalog numbers upon request.

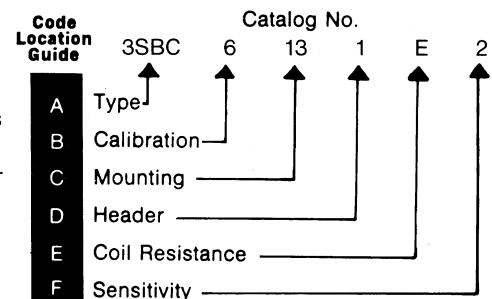

Mounting Forms (3SBC, 3SCC)

(Vibration note with each form is acceleration from 55 to 3000 Hz)

All dimensions in inches

TOLERANCES (Unless otherwise specified)	
Hundredths	± 0.020
Thousandths	± 0.005

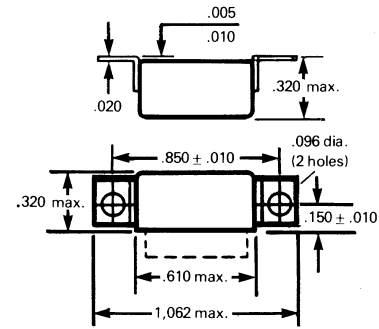
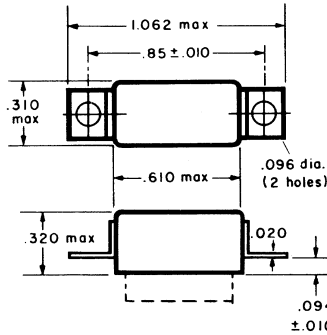
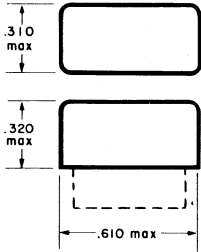

No Mount

End Bracket

Side Bracket

Mounting Code	Vibration
00	30g

Mounting Code	Vibration
13	30g

Mounting Code	Vibration
25	30g

*Assumes relay held securely by potting or other means

HEADER AND CONNECTION DIAGRAMS

HEADER TYPES

TYPE	Z DIMENSION	HEADER CODE
Solder hook	0.13	1
Straight pin	0.12	8
Straight pin	0.19	4
Straight pin	0.25	5

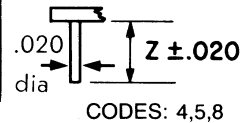
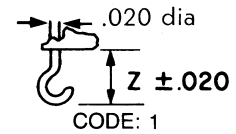

CODE 1, 5, & 6

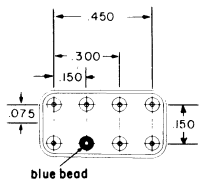

CODE 2

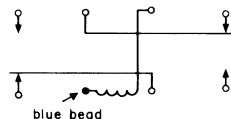
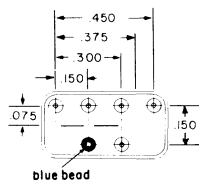

CODE 1

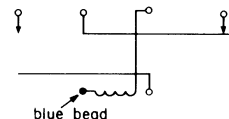

CODE 2

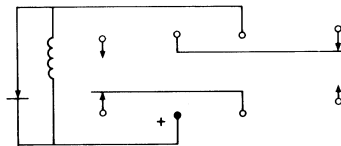

CODE 5
SINGLE DIODE

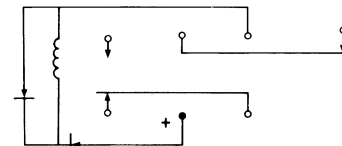

CODE 6
DUAL DIODE

TERMINAL VIEW

C

D

F



Magnetic-latching, Grid-space, Micro-miniature Relays

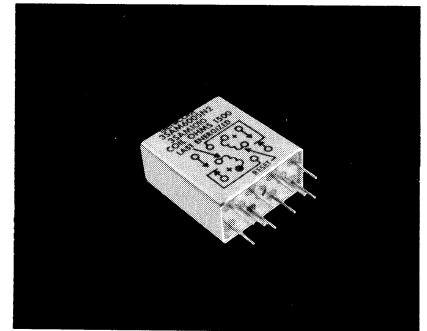

A

Type 3SAM (2PDT)

Features

- Special shock designs up to 700G, 1 ms
- Suitable for pulse operation
- No hang up feature on low power pulses
- MIL-R-39016/32
- Special wiring is available

Description

This relay has 'memory' in that the contact positions do not change when coil power is removed. Switching is accomplished by applying power to the applicable coil (dual coil) or with the applicable polarity (single coil). The low switching power requirements are further enhanced by its ability to operate from capacitor discharge or other pulses or through its own contacts for batteries or similarly limited supplies.

Other Specifications

Contact Ratings:

DC resistive—2 amps at 28 volts
 DC inductive—0.5 amps at 28 volts, 200 mH
 AC resistive—1 amp at 115 volts, (single coil) case not grounded
 AC resistive—.25 amp at 115 volts, (dual coil) cast not grounded
 Low-level—50 μ A at 50 mV Peak AC or DC

Contact Resistance:

0.050 ohms initial
 0.100 ohms after life test

Life:

100,000 operations at rated load;
 1,000,000 operations at low-level

Operate Time:

4 ms

Reset Time:

4 ms

Bounce:

2 ms

Dielectric Strength:

1,000 volts RMS at sea level; 700 volts RMS across contact gap

Insulation Resistance:

1,000 megohms minimum

Vibration:

30G, to 3000 Hz

Shock:

150G at 11 ms

Temperature:

–65C to +125C

See page 35 for Mounting Forms, Terminals and Circuit Diagrams.

F

B

E

Coil Table (All Values DC) Single Coil
 50 mW Sensitivity: (Code: 1)

Coil Code Letter	Current Calibrated, CODE: 6		
	Coil Resistance @25C (Ohms)	Max Operate and Reset Current (mA) ‡	Suggested Source Voltage†
A	16.4 ± 10%	55.2	1.8–4.8
B	40 ± 10%	35.3	2.7–7.5
C	96 ± 10%	22.8	4.2–11.0
D	164 ± 10%	17.4	5.5–15.0
E	260 ± 10%	13.9	7.0–19.0
F	400 ± 10%	11.2	8.5–23.0
H	600 ± 10%	9.2	11.0–29.0
K	960 ± 10%	7.2	13.0–37.0
L	1350 ± 10%	6.1	16.0–43.0
M	1950 ± 10%	5.1	19.0–52.0
N	3000 ± 15%	4.1	25.0–64.0
P	4800 ± 15%	3.3	32.0–81.0
R	8200 ± 20%	2.5	43.0–99.0

† Applicable over the operating temperature range in circulating air.
 ‡ Initial or inspection value. Allow 20% increase in value of maximum pickup during rated life.

Coil Table (All Values DC) Dual Coil
 75 mW Sensitivity: (Code: 2)

Coil Code Letter	Current Calibrated, CODE: 6		
	Coil Resistance @25C For Each Coil (Ohms)	Max† Operate Current For Each Coil (mA)	Suggested Source Voltage For Each Coil†
A	8.2 ± 10%	95.8	1.5–2.6
B	20 ± 10%	61.2	2.3–4.1
C	48 ± 10%	39.5	3.6–6.3
D	82 ± 10%	30.2	4.7–8.3
E	130 ± 10%	24.0	6.0–10.0
F	200 ± 10%	19.4	7.4–13.0
H	300 ± 10%	15.8	9.0–16.0
K	480 ± 10%	12.5	12.0–20.0
L	675 ± 10%	10.6	14.0–24.0
M	975 ± 10%	8.8	16.0–29.0
N	1500 ± 15%	7.1	21.0–35.0
P	2400 ± 15%	5.6	27.0–44.0
R	4100 ± 20%	4.3	37.0–55.0

† Applicable over the operating temperature range in circulating air.
 ‡ Initial or inspection value. Allow 20% increase in value of maximum operate and reset during rated life.

ORDERING INSTRUCTIONS

Example: The relay selected in this example is a 2PDT magnetic latching relay, current calibrated, four-hole end bracket mounting, solder hook header, 1500 ohms coil resistance, and 75 mW sensitivity. By choosing the proper code for each of these relay characteristics, the catalog number is identified as 3SAM6014N2. The letter R following sensitivity code indicates relay received 5000 operation miss-test. Ex. 3SAM6014N2R.

Code Location Guide

A
B
C
D
E
F

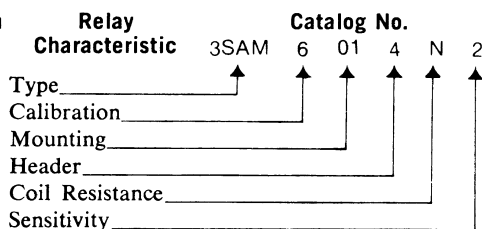

Mounting Forms (3SAM)

(Vibration note with each form is acceleration from 55 to 3000 Hz)

All dimensions in inches

TOLERANCES (unless otherwise specified)	
Hundredths	±0.020
Thousandths	±0.005

No Mount

Mounting Code	Vibration*
00	30g

* Assumes relay securely held by potting or other means.

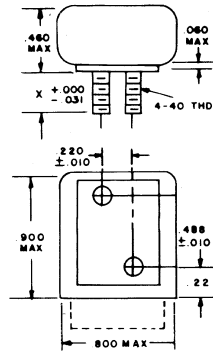
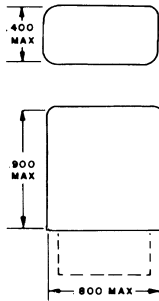

Side Studs

Mounting Code	X Dim.	Vibration
07	0.250	30g
08	0.375	30g

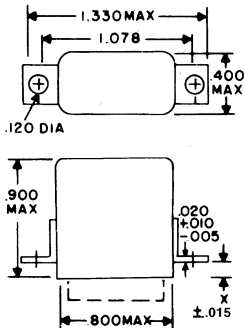

Two-hole End Bracket

Mounting Code	X Dim.	Vibration
13	0.125	30g
14	0.250	30g
15	0.450	30g

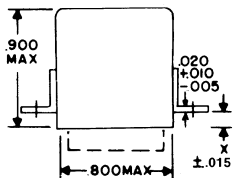

Top Studs

Mounting Code	X Dim.	Vibration
10	0.250	30g
11	0.375	30g

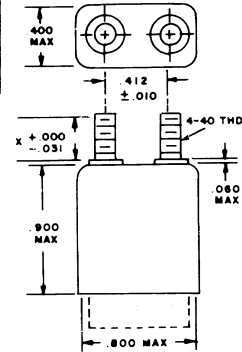

Four-hole End Bracket

Mounting Code	X Dim.	Vibration
01	0.125	30g
02	0.250	30g
03	0.450	30g

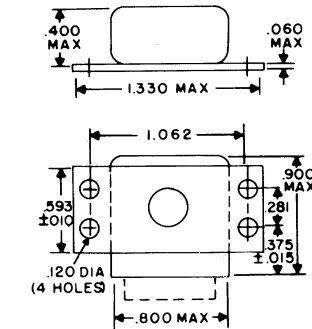
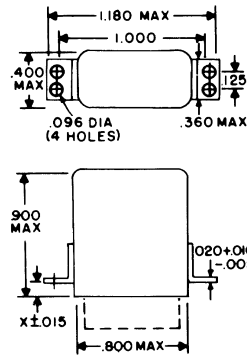

Four-hole Side Bracket

Mounting Code	Vibration
06	30g

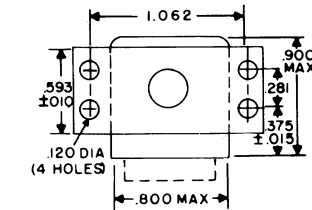

Header and Connection Diagrams

Single Coil (Terminal View) Dual Coil
(+ on blue bead closes as shown)

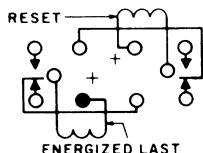
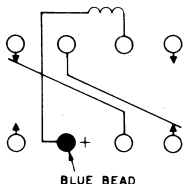
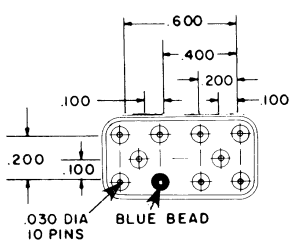
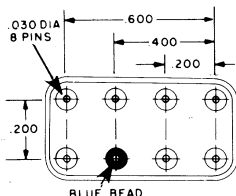

Header Types

Type	Z Dimension	Header Code	
		Single	Dual
Solder hook	0.16	1	4
Straight pin (socket or PCB type)	0.19	2	5

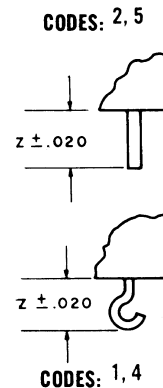

C
D



Code
Location
Guide

Crystal-can Micro-miniature Relays

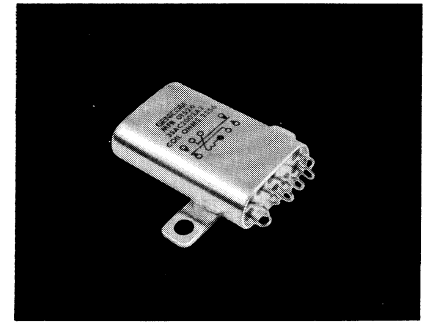

A

Type 3SAE (2PDT) Type 3SAC (2PDT)

Features

- Small lightweight crystal can type
- 0.25 cubic inch, 0.60 ounces
- Power or low-level switching
- 20G to 2000 Hz vibration capability

Description

CIIT's line of micro-miniature crystal can relays is backed by years of experience and millions of relays operating in the field.

Other Specifications

Contact Ratings:

DC resistive — 2 amps at 28 volts
DC inductive — 1 amp at 28 volts,
L/R < .025

Low-level — 50 μ A at 50 mV
Peak AC or DC
AC resistive — 1.0 amp at 115 volts,
case not grounded
AC resistive — 0.25 amps at 115 volts,
case grounded

Contact Resistance:

0.050 ohms max. initial
0.100 ohms max. after life test

Life:

100,000 operations at rated load
1,000,000 at low-level

Operate Time:

6 ms max.

Release Time:

5 ms max.

Bounce:

2.5 ms

Dielectric Strength:

1,000 VRMS at sea level;
700 VRMS across contact gaps;
350 VRMS at 70,000 feet

Insulation Resistance:

1,000 megohms minimum except coil
to case 500 minimum at 125C

Vibration:

Depends upon mounting forms

Shock:

50G at 11 ms

Temperature:

–65C to +125C

See page 39 for Mounting Forms,
Terminals and Circuit Diagrams.

F

Coil Table (All Values DC)*
Type 3SAE 330 mW Sensitivity: (Code 1)

Coil Code Letter	Voltage Calibrated, CODE: 5				
	Coil Resistance at 25C (Ohms)	Suggested Source Volts†	Maximum Operate Volts at 25C	Release Voltage at 25C	
				Max	Min
A	22 \pm 10%	3.9– 5.9	2.7	1.4	0.29
B	34 \pm 10%	4.8– 7.4	3.3	1.7	0.36
C	53 \pm 10%	6.2– 9.2	4.2	2.2	0.46
D	92 \pm 10%	8.0–12.0	5.4	2.8	0.60
E	146 \pm 10%	10.2–15.0	6.9	3.6	0.76
F	215 \pm 10%	12.3–18.5	8.3	4.3	0.92
H	342 \pm 10%	15.4–23.0	10.4	5.4	1.16
K	552 \pm 10%	20.0–29.5	13.5	7.0	1.50
L	814 \pm 10%	25.0–36.0	16.9	8.8	1.88
M	1180 \pm 10%	30.0–43.0	20.5	10.6	2.28
N	1278 \pm 15%	31.0–41.5	21.3	11.0	2.36
P	1800 \pm 15%	38.0–49.0	25.8	13.3	2.86
R	2530 \pm 15%	43.0–58.5	29.0	15.0	3.22
S	2950 \pm 15%	50.0–63.0	34.0	17.5	3.77
T	5000 \pm 20%	62.0–75.0	41.8	21.6	4.64
V	5170 \pm 20%	68.0–76.0	46.0	25.4	5.12

Coil Table (All Values DC)*
Type 3SAC 200 mW Sensitivity: (Code 2)

Coil Code Letter	Current Calibrated, CODE: 6				
	Coil Resistance at 25C (Ohms)	Maximum Operate Current at 25C (mA)	Maximum Continuous Current at 125C (mA)	Release Current at 25C (mA)	
				Max	Min
A	184 \pm 10%	32.0	65.0	16.5	3.53
B	292 \pm 10%	25.6	51.5	13.3	2.84
C	430 \pm 10%	20.8	42.5	10.8	2.31
D	684 \pm 10%	16.4	33.5	8.5	1.80
E	1104 \pm 10%	13.2	26.5	6.9	1.46
F	1628 \pm 10%	11.2	21.7	5.8	1.24
H	2360 \pm 15%	9.4	16.8	4.9	1.04
K	2556 \pm 15%	9.0	16.2	4.7	0.99
L	3600 \pm 15%	7.7	13.5	4.1	0.86
M	5060 \pm 15%	6.2	11.5	3.3	0.69
N	5900 \pm 15%	6.2	10.5	3.3	0.71
P	10000 \pm 20%	4.5	7.5	2.4	0.50
R	10340 \pm 20%	4.8	7.4	2.5	0.54

* Values listed are factory test and inspection values. User should allow for meter variations.

† Applicable over the operating temperature range in circulating air.

ORDERING INSTRUCTIONS

Example: The relay selected in this example is a 2PDT crystal can relay, voltage calibrated, two-hole side bracket mount-

ing, solder hook header, 552 ohms coil resistance, and 330 mW sensitivity. By choosing the proper code for each of these relay characteristics, the catalog number is identified as 3SAE5041K1. The letter R following sensitivity code indicates relay received 5000 operations miss-test. Ex. 3SAE5041K1R.

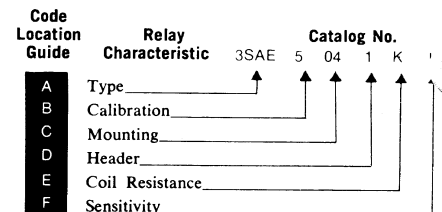

Mounting Forms (3SAC, 3SAE)

(Vibration note with each form is acceleration from 55 to 2000 Hz)

All dimensions in inches

TOLERANCES (unless otherwise specified)	
Hundredths	±0.020
Thousandths	±0.005

Code Location Guide

No Mount

Mounting Code	A Dim. (Max)	Vibration*	Relay Type
00	0.875	20g	3SAE
00	1.187	15g	3SAC

* Assumes relay securely held by potting or other means.

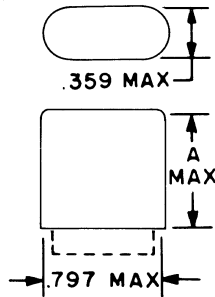

Flange Mount, 2 in-line holes

Mounting Code	A Dim. (Max)	X Dim.	Vibration	Relay Type
13	0.875	0.125	15g	3SAE
13	1.187	0.125	10g	3SAC
14	0.875	0.375	20g	3SAE
14	1.187	0.455	15g	3SAC

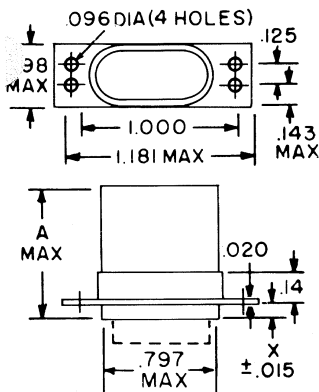
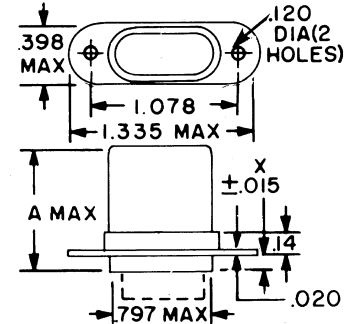

Four-hole Flange

Mounting Code	A Dim. (Max)	X Dim.	Vibration	Relay Type
01	0.875	0.125	15g	3SAE
01	1.187	0.125	10g	3SAC
02	0.875	0.375	20g	3SAE
02	1.187	0.455	15g	3SAC

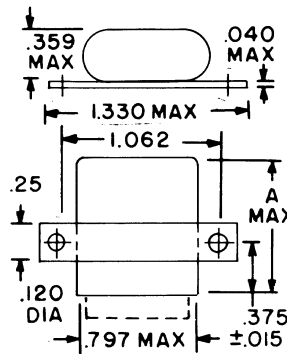

Two-hole Side Bracket

Mounting Code	A Dim. (Max)	Vibration	Relay Type
04	0.875	20g	3SAE
04	1.187	15g	3SAC

Side Studs

Mounting Code	A Dim. (Max)	C Dim.	X Dim.	Vibration	Relay Type
07	0.875	0.488	0.375	20g	3SAE
07	1.187	0.800	0.375	15g	3SAC
08	0.875	0.488	0.250	20g	3SAE
08	1.187	0.800	0.250	15g	3SAC

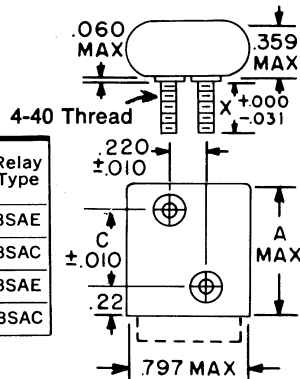

Top Studs

Mounting Code	A Dim. (Max)	X Dim.	Vibration	Relay Type
10	0.940	0.375	20g	3SAE
10	1.252	0.375	15g	3SAC
11	0.940	0.250	20g	3SAE
11	1.252	0.250	15g	3SAC

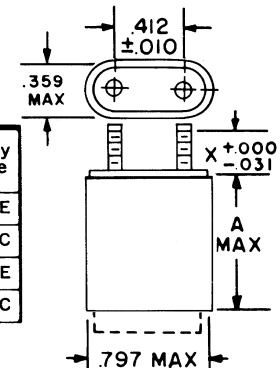

Header and Connection Diagrams

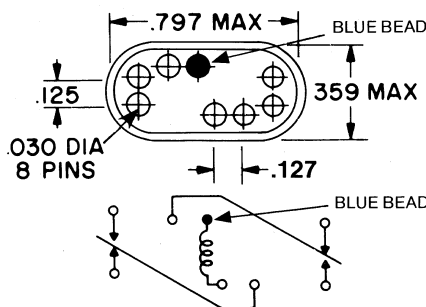

Header Types

Type	Z Dim.	Header Code
Solder hook	0.19	3
Straight pin (socket or PCB type)	0.19	4
Straight pin	2.99	8

CODE: 3

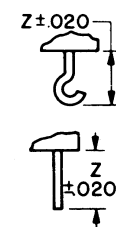

CODES: 4, 8

C

D

1MS • 1MSD • 1MSDD • 1MST

TO-5 HIGH-PERFORMANCE RELAYS

1MS

**SENSITIVE TO-5
HIGH-PERFORMANCE RELAY**

**QUALIFIED TO
MIL-R-39016/10**

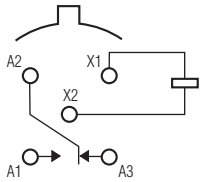

TERMINAL VIEW

FEATURES

- Hermetically sealed
- High shock & vibration ratings
- Spreader pad
- Excellent RF switching

1MSD

**SENSITIVE TO-5
DIODE SUPPRESSED
HIGH-PERFORMANCE RELAY**

**QUALIFIED TO
MIL-R-39016/25**

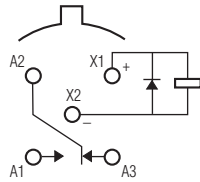

TERMINAL VIEW

FEATURES

- Suppression diode
- Hermetically sealed
- High shock & vibration ratings
- Spreader pad
- Excellent RF switching

1MSDD

**SENSITIVE TO-5 DIODE
SUPPRESSED/PROTECTED
HIGH-PERFORMANCE RELAY**

**QUALIFIED TO
MIL-R-39016/26**

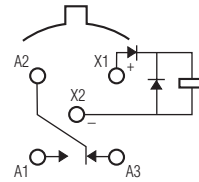

TERMINAL VIEW

FEATURES

- Suppression & protection diodes
- Hermetically sealed
- High shock & vibration ratings
- Spreader pad
- Excellent RF switching

1MST

**SENSITIVE TO-5 DIODE
SUPPRESSED/TRANSISTOR DRIVEN
HIGH-PERFORMANCE
RELAY**

**QUALIFIED TO
MIL-R-28776/4**

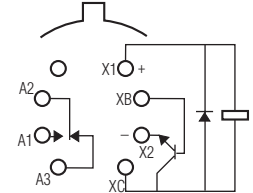

TERMINAL VIEW

FEATURES

- Transistor driver & suppression diode
- Hermetically sealed
- High shock & vibration ratings
- Spreader pad
- Excellent RF switching

ELECTRICAL CHARACTERISTICS

CONTACT ARRANGEMENT
1 Form C (SPDT)

CONTACT MATERIAL
Stationary:
Gold/platinum/palladium/silver alloy (gold plated)

Moveable:
Gold/platinum/palladium/silver alloy (gold plated)

CONTACT RESISTANCE
Before Life: 100 milliohms max. (measured @ 10 mA @ 6 Vdc)
After Life: 200 milliohms max. (measured @ 1 A @ 28 Vdc)

MECHANICAL LIFE EXPECTANCY
1 million operations

COIL VOLTAGE
5 to 40 Vdc

COIL POWER
506 mW max. @ 25°C

DUTY CYCLE
Continuous

PICK-UP VOLTAGE
Approximately 50% of nominal coil voltage

PICK-UP SENSITIVITY
40 mW max. @ 25°C



CONTACT RATINGS

CONTACT LOAD	TYPE	OPERATIONS MIN.
1.0 A @ 28 Vdc	Resistive	100,000
250 mA @ 115 Vac, 60 Hz & 400 Hz	Resistive (case not grounded)	100,000
100 mA @ 115 Vac, 60 Hz & 400 Hz	Resistive	100,000
0.2 A @ 28 Vdc	Inductive (0.32 Henry)	100,000
0.1 A @ 28 Vdc	Lamp	100,000
30 mA @ 50 mVdc	Low Level	1,000,000
0.1 A @ 28 Vdc	Intermediate Current	50,000

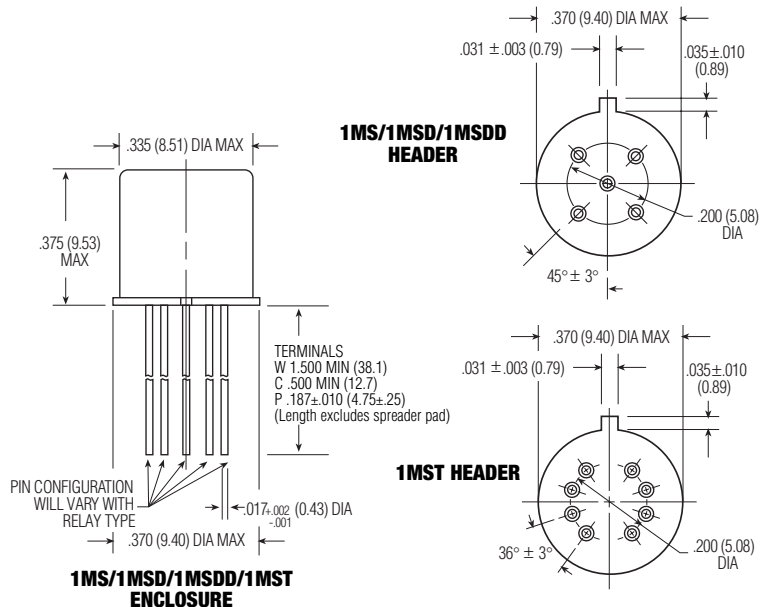

1MA · 1MAD · 1MADD · 1MAT

TO-5 HIGH-PERFORMANCE RELAYS

1MA

**STANDARD TO-5
HIGH-PERFORMANCE RELAY**

**QUALIFIED TO
MIL-R-39016/7**

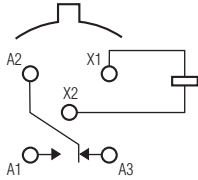

TERMINAL VIEW

FEATURES

- Hermetically sealed
- High shock & vibration ratings
- Spreader pad
- Excellent RF switching

1MAD

**STANDARD TO-5
DIODE SUPPRESSED
HIGH-PERFORMANCE RELAY**

**QUALIFIED TO
MIL-R-39016/23**

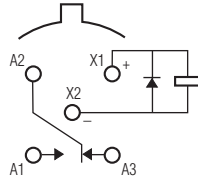

TERMINAL VIEW

FEATURES

- Suppression diode
- Hermetically sealed
- High shock & vibration ratings
- Spreader pad
- Excellent RF switching

1MADD

**STANDARD TO-5 DIODE
SUPPRESSED/PROTECTED
HIGH-PERFORMANCE RELAY**

**QUALIFIED TO
MIL-R-39016/24**

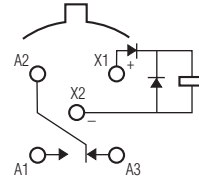

TERMINAL VIEW

FEATURES

- Suppression & protection diodes
- Hermetically sealed
- High shock & vibration ratings
- Spreader pad
- Excellent RF switching

1MAT

**STANDARD TO-5 DIODE
SUPPRESSED/TRANSISTOR DRIVEN
HIGH-PERFORMANCE
RELAY**

**QUALIFIED TO
MIL-R-28776/5**

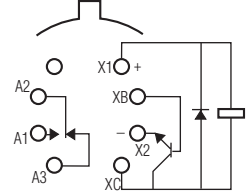

TERMINAL VIEW

FEATURES

- Transistor driver & suppression diode
- Hermetically sealed
- High shock & vibration ratings
- Spreader pad
- Excellent RF switching

ELECTRICAL CHARACTERISTICS

CONTACT ARRANGEMENT
1 Form C (SPDT)

CONTACT MATERIAL
Stationary:
Gold/platinum/palladium/silver alloy (gold plated)

Moveable:
Gold/platinum/palladium/silver alloy (gold plated)

CONTACT RESISTANCE
Before Life: 100 milliohms max. (measured @ 10 mA @ 6 Vdc)
After Life: 200 milliohms max. (measured @ 1 A @ 28 Vdc)

MECHANICAL LIFE EXPECTANCY
1 million operations

COIL VOLTAGE
5 to 26 Vdc

COIL POWER
512 mW max. @ 25°C

DUTY CYCLE
Continuous

PICK-UP VOLTAGE
Approximately 50% of nominal coil voltage

PICK-UP SENSITIVITY
100 mW max. @ 25°C

CONTACT RATINGS

CONTACT LOAD	TYPE	OPERATIONS MIN.
1.0 A @ 28 Vdc	Resistive	100,000
250 mA @ 115 Vac, 60 Hz & 400 Hz	Resistive (case not grounded)	100,000
100 mA @ 115 Vac, 60 Hz & 400 Hz	Resistive	100,000
0.2 A @ 28 Vdc	Inductive (0.32 Henry)	100,000
0.1 A @ 28 Vdc	Lamp	100,000
30 mA @ 50 mVdc	Low Level	1,000,000
0.1 A @ 28 Vdc	Intermediate Current	50,000

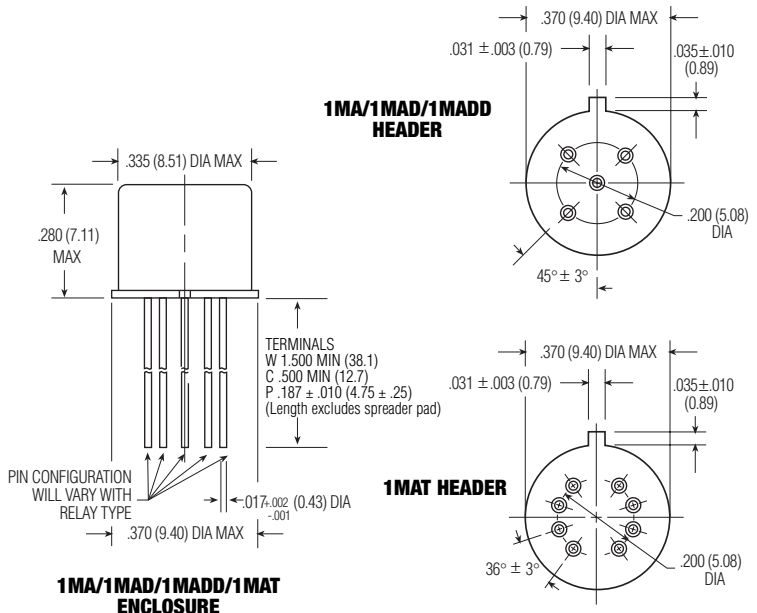

OPERATING CHARACTERISTICS

TIMING

Operate Time:
2.0 ms max.

Release Time:
1MA: 2.0 ms max.
1MAD/1MADD: 4.0 ms max.
(suppression diode,
suppression/steering diodes)
1MAT: 4.0 ms max.
(transistor driven)

CONTACT BOUNCE

1.5 ms max

DIELECTRIC WITHSTANDING VOLTAGE

Between Open Contacts:
500 Vrms 60 Hz

Between Adjacent Contacts:
500 Vrms 60 Hz

Between Contacts & Coil:
500 Vrms 60 Hz

INSULATION RESISTANCE

10,000 megohms @ 500 Vdc
1,000 megohms @ 500 Vdc
(coil to case @ +125°C)

ENVIRONMENTAL CHARACTERISTICS

TEMPERATURE RANGE

-65°C to +125°C

WEIGHT

0.08 oz. (2.27 grms)
0.19 oz. (2.52 grms) with spreader
pad attached

VIBRATION RESISTANCE

30 G's, 10 to 3,000 Hz

SHOCK RESISTANCE

75 G's, 6 ±1 ms max.

QPL APPROVAL

MIL-R-39016/7 (J1MA)
MIL-R-39016/23 (J1MAD)
MIL-R-39016/24 (J1MADD)
MIL-R-28776/5 (J1MAT)

SEMICONDUCTOR CHARACTERISTICS

DIODE

100 Vdc peak inverse voltage (PIV)
1.0 Vdc max. transient voltage

TRANSISTOR

0.3 Vdc min. base turn off voltage
6.0 Vdc min. emitter-base
breakdown voltage (BV_{EBO}) @ 25°C
80.0 Vdc min. collector-base
breakdown voltage (BV_{CBO}) @ 25°C
& I_C=100 mA

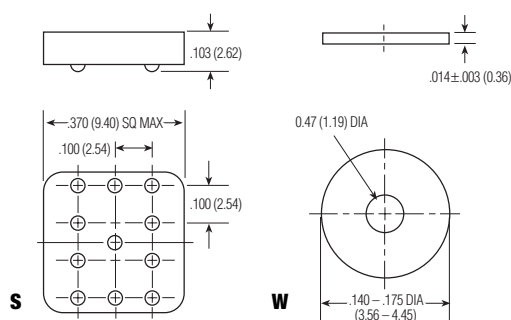

SPREADER & MOUNTING PADS

COIL DATA

NOM. COIL VOLTAGE (Vdc)	COIL RESISTANCE IN OHMS ±10% @ 25°C (Note 1)	COIL CIRCUIT CURRENT mA (MAX.) (Note 1&2)	COIL CIRCUIT CURRENT mA (MIN.) (Note 1&2)	PICKUP VOLTAGE Vdc (MAX.) @ 25°C (Note 2)	BASE TURN ON CURRENT mA (MAX.) @ 25°C	PICKUP VOLTAGE Vdc (MAX.) @ 125°C (Note 2)	BASE TURN ON CURRENT mA (MAX.) @ 125°C	DROP-OUT VOLTAGE Vdc (MIN.) @ 25°C (Note 2)	DROP-OUT VOLTAGE Vdc (MIN.) @ -65°C (Note 2)	NOM. COIL POWER (mW) @ 25°C	MAX. COIL VOLTAGE	COIL DESIG.
1MA/1MAD												
5.0	63	n/a	n/a	2.8	n/a	3.7	n/a	0.23	0.15	397	6.0	5
6.0	125	n/a	n/a	3.5	n/a	4.5	n/a	0.28	0.18	288	8.0	6
9.0	280	n/a	n/a	5.3	n/a	6.8	n/a	0.54	0.35	289	12.0	9
12.0	500	n/a	n/a	7.0	n/a	9.0	n/a	0.63	0.40	288	16.0	12
18.0	1,130	n/a	n/a	10.5	n/a	13.5	n/a	0.91	0.58	287	24.0	18
26.5	2,000	n/a	n/a	14.2	n/a	18.0	n/a	1.37	0.89	351	32.0	26
1MADD												
5.0	50	100.0	72.7	3.5	n/a	4.5	n/a	0.23	0.15	500	6.0	5
6.0	98	62.4	46.3	4.1	n/a	5.5	n/a	0.28	0.18	367	8.0	6
9.0	280	33.7	25.9	6.3	n/a	7.8	n/a	0.54	0.35	289	12.0	9
12.0	500	25.6	20.0	8.0	n/a	10.0	n/a	0.63	0.40	288	16.0	12
18.0	1,130	17.2	13.6	11.6	n/a	14.5	n/a	0.91	0.58	287	24.0	18
26.5	2,000	14.4	11.5	15.4	n/a	19.0	n/a	1.37	0.89	351	32.0	26
1MAT												
5.0	63	89.6	66.6	3.0	0.60	3.9	2.38	0.24	0.15	397	5.8	5
6.0	125	55.5	42.0	3.8	0.42	5.2	1.60	0.31	0.18	288	8.0	6
9.0	280	38.1	28.0	5.6	0.27	7.8	1.07	0.47	0.35	289	12.0	9
12.0	500	28.1	20.9	7.2	0.21	10.0	0.80	0.62	0.40	288	16.0	12
18.0	1,130	18.8	13.8	10.7	0.12	14.5	0.53	0.94	0.58	287	24.0	18
26.5	2,000	15.5	11.5	14.4	0.10	19.0	0.40	1.25	0.89	351	32.0	26

Note 1: Coil resistance not directly measurable. Coil current should be within limits shown when tested at nominal voltage at 25°C for 5 seconds max.
Note 2: Set base current at 3 mA to 15 mA during measurements.

SPECIFYING A PART NUMBER EXAMPLE:	TYPE	TERMINAL	DIODES TRANSISTOR	COIL	SPREADER/MOUNTING PADS
	1MA	C	D	-26	S



X-ON Electronics

Largest Supplier of Electrical and Electronic Components

Click to view similar products for [Gate Drivers](#) category:

Click to view products by [TE Connectivity](#) manufacturer:

Other Similar products are found below :

[00053P0231](#) [8967380000](#) [56956](#) [CR7E-30DB-3.96E\(72\)](#) [57.404.7355.5](#) [LT4936](#) [57.904.0755.0](#) [5803-0901](#) [58410](#) [5882900001](#) [00600P0005](#)
[00-9050-LRPP](#) [00-9090-RDPP](#) [5951900000](#) [01-1003W-10/32-15](#) [LTLA6E-1S-WH-RC-FN12VXCR1](#) [0131700000](#) [00-2240](#) [LTP70N06](#)
[LVP640](#) [0158-624-00](#) [5J0-1000LG-SIL](#) [020017-13](#) [LY1D-2-5S-AC120](#) [LY2-0-US-AC120](#) [LY2-US-AC240](#) [LY3-UA-DC24](#) [00-5150](#)
[00576P0020](#) [00600P0010](#) [LZNQ2M-US-DC5](#) [LZNQ2-US-DC12](#) [LZP40N10](#) [00-8196-RDPP](#) [00-8274-RDPP](#) [00-8275-RDNP](#) [00-8609-](#)
[RDPP](#) [00-8722-RDPP](#) [00-8728-WHPP](#) [00-8869-RDPP](#) [00-9051-RDPP](#) [00-9091-LRPP](#) [00-9291-RDPP](#) [0207100000](#) [0207400000](#) [60100564](#)
[01312](#) [0134220000](#) [6035](#) [M15730061](#)