

REVISIONS					
REV	DATE	DESCRIPTION	BY	CHK	APPV
A1	24APR10	REVISED PER ECO-10-008611	HMR	NE	
A2	30MAY2017	REVISED PER ECO-16-018096	RK	PO	

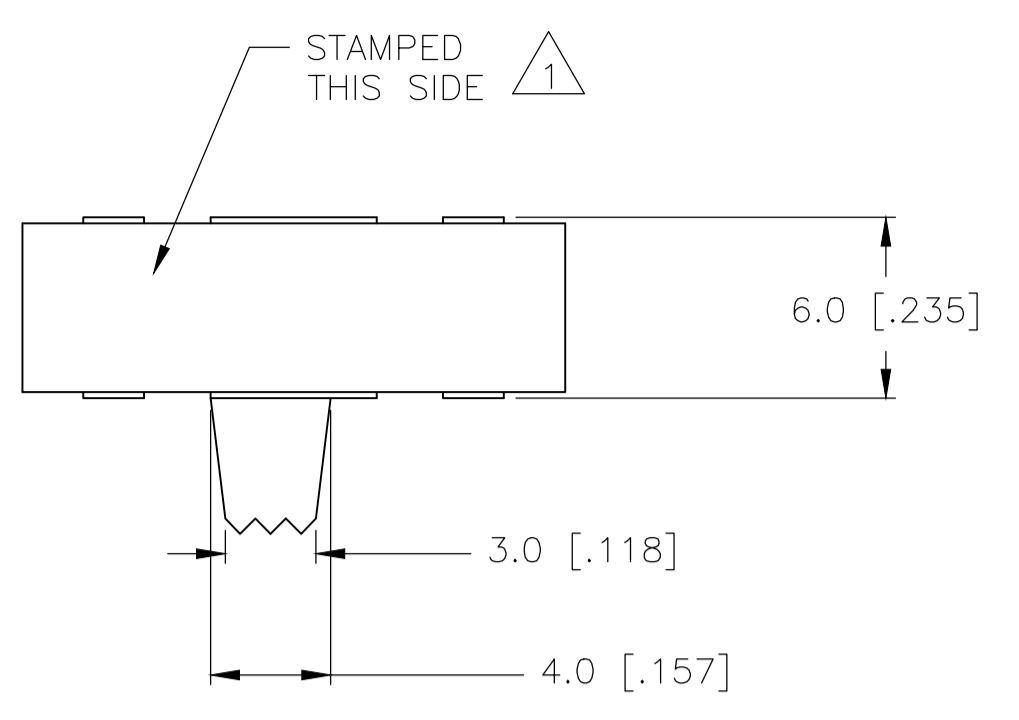

SPECIFICATIONS
MAKE-BEFORE-BREAK

MATERIALS:
 ACTUATOR- POM, UL94HB BLACK
 TERMINAL BOARD- PHENOLIC LAMINATED SHEET, UL94HB, NATURAL
 FRAME- STEEL, NICKEL PLATE
 TERMINAL/FIXED CONTACT- COPPER ALLOY, GOLD OR SILVER OVER NICKEL PLATE
 MOVING CONTACT- COPPER ALLOY, GOLD OR SILVER OVER NICKEL PLATE
 DETENT BALL- STEEL
 COIL SPRING- GALVANIZED SPRING WIRE
 SEAL- EPOXY

ELECTRICAL:
 CONTACT RATING- .4VA@20VDC OR PEAK AC (GOLD); 300mA@125V AC (SILVER)
 INITIAL CONTACT RESISTANCE- 30 milliohm max.
 FINAL CONTACT RESISTANCE- 100 milliohm max. (AFTER TEST)
 INSULATION RESISTANCE- 1,000 Megohms min.
 DIELECTRIC STRENGTH- 500V RMS@SEA LEVEL
 LIFE EXPECTANCY- 15,000 CYCLES MIN.

MECHANICAL:
 ACTUATION FORCE- 600+/-300 GRAMS
 TRAVEL- 2.0 +/-0.50 (0.079 +/-0.020)

ENVIRONMENTAL:
 OPERATING TEMPERATURE- -20 TO +85 DEGREES C
 STORAGE TEMPERATURE- -40 TO +100 DEGREES C
 RESISTANCE TO SOLDER HEAT PER 109-202, CONDITION B
 SOLDERABILITY PER EIA-364-52, CLASS 2, CATEGORY 1, 95% MIN COVERAGE

NOTES:

1. COUNTRY OF ORIGIN AND TE LOGO LOCATED APPROXIMATELY AS SHOWN
2. ALL MATERIALS AND FINISHES SHALL COMPLY WITH EU DIRECTIVE 2002/95/EC OF 27JAN2003 (ROHS)
3. ANTI SOLDER WICK SEAL AT TERMINAL TO BOARD INTERFACE
4. ALL PERFORMANCE TESTING WAS DONE IN ACCORDANCE TO TE SPECIFICATION 102-2469

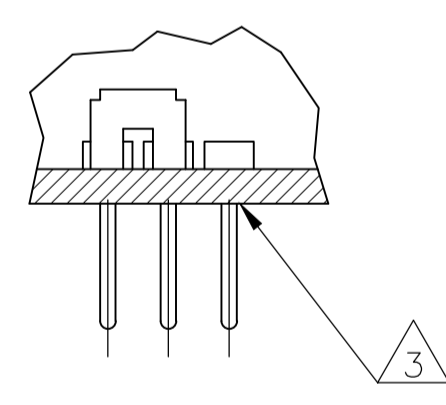
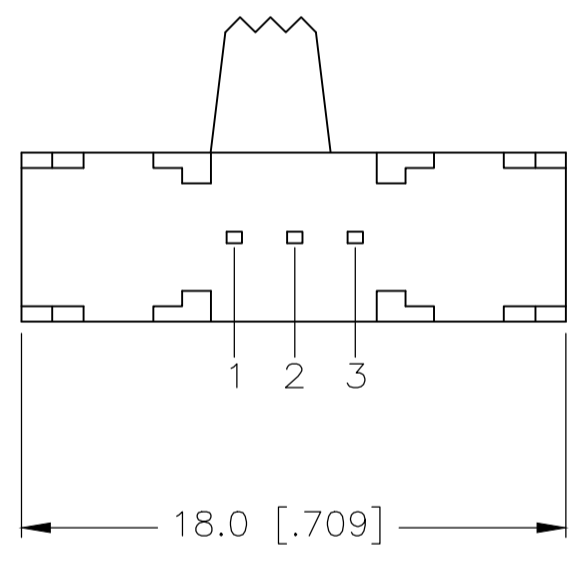
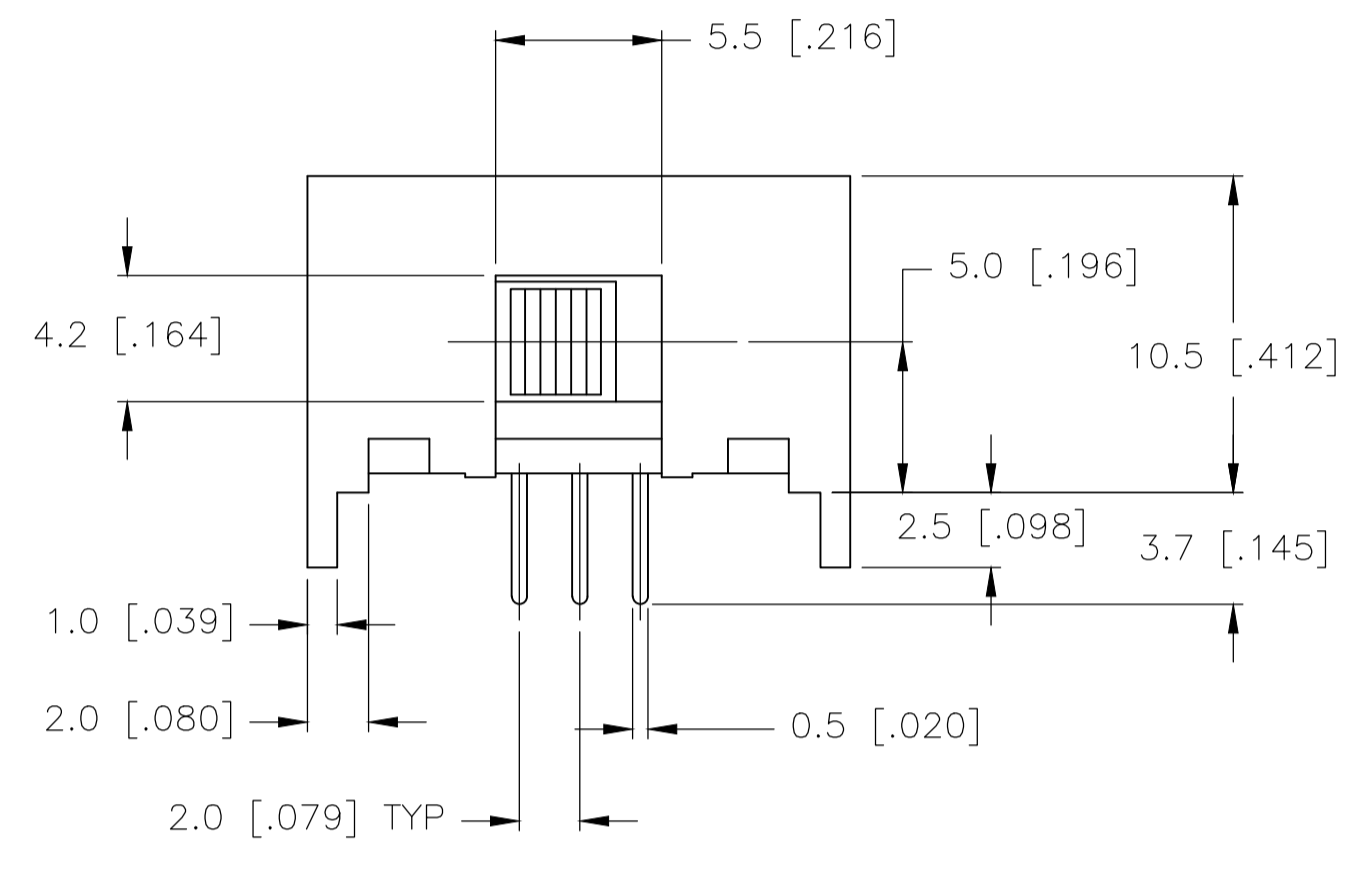
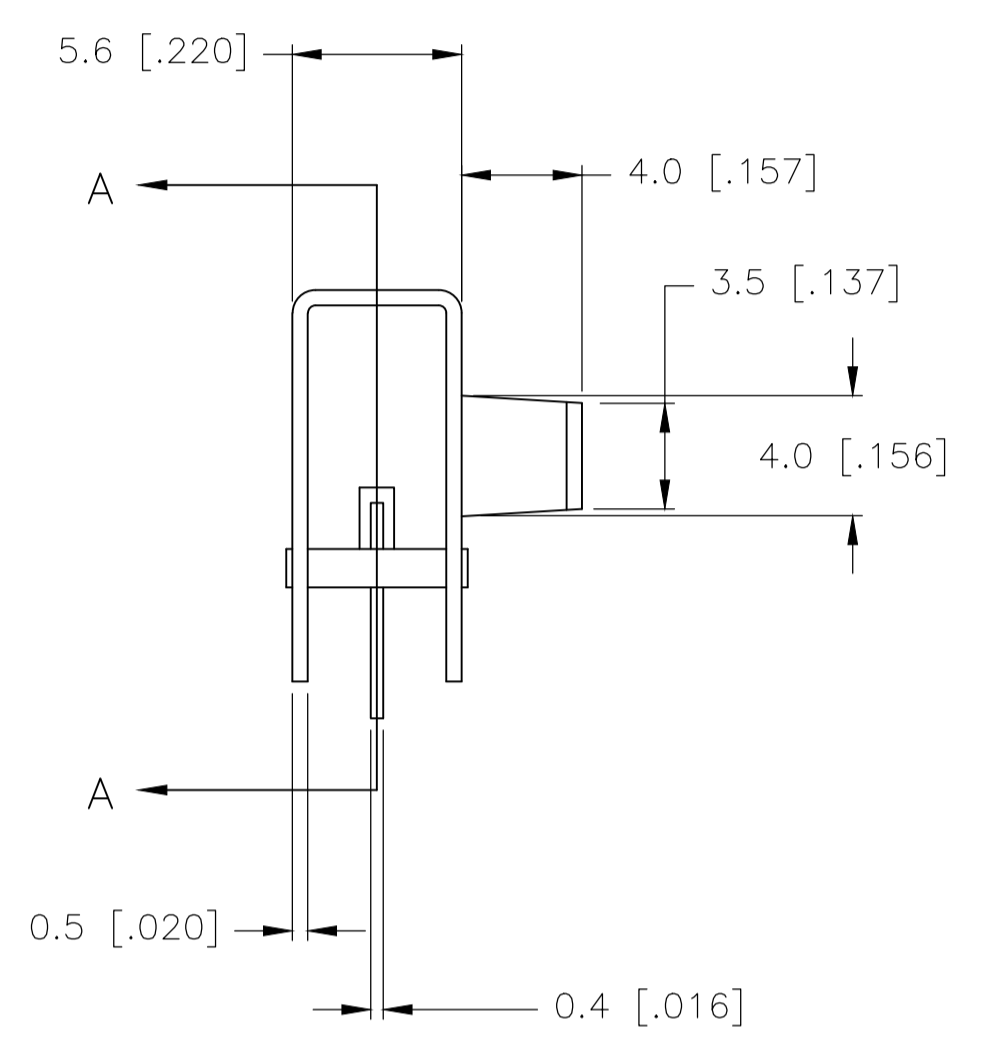

SECTION A-A

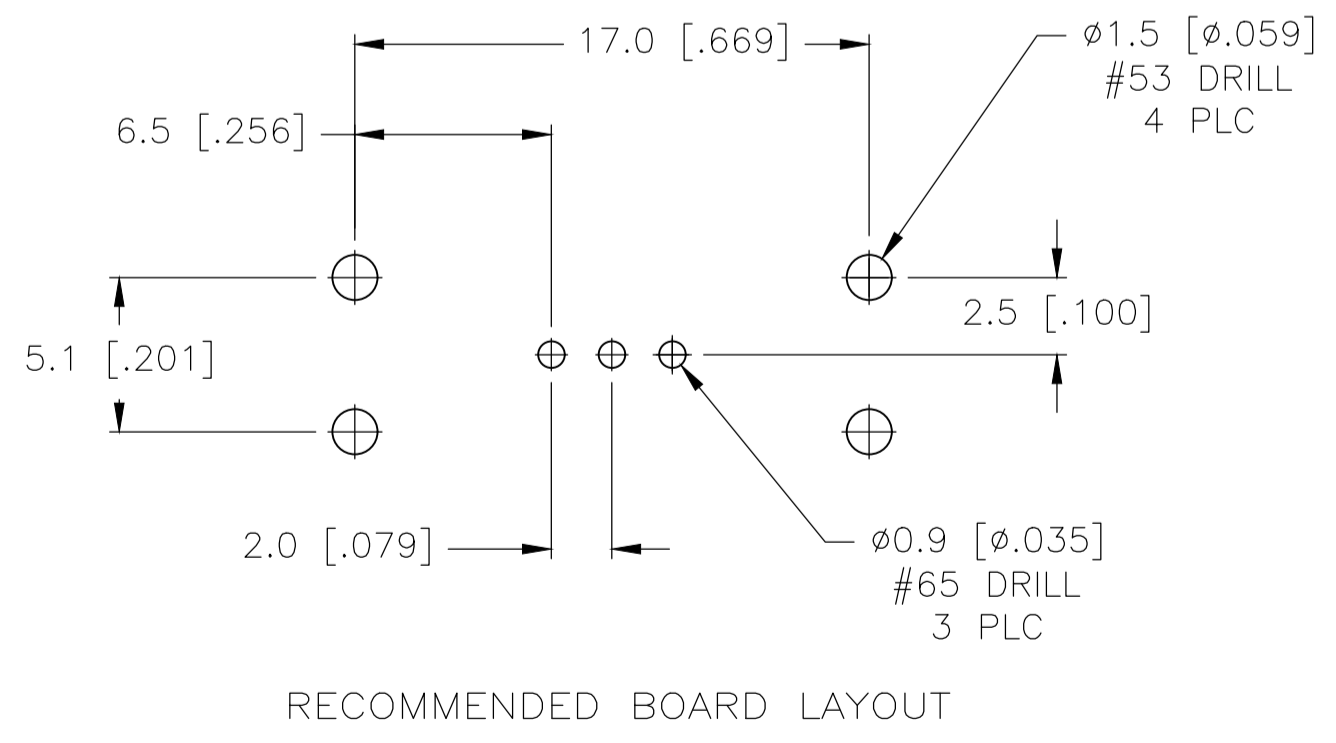

RECOMMENDED BOARD LAYOUT

	1825258-2	MSS1200RG04	GOLD	2 TO 1	2 TO 3
OBSOLETE	1825258-1	MSS1200R04	SILVER	2 TO 1	2 TO 3
	TE PART NO.	T&B PART NO.	PLATING		
TERMINALS CONNECTED WHEN SLIDE IS IN POSITION SHOWN.					

THIS DRAWING IS A CONTROLLED DOCUMENT. DIN R BROWN 20DEC05. CHK M SARVER 20DEC05. APVD M SARVER 20DEC05. NAME SLIDE SWITCH, MSS 1200R SERIES, SP-DT, RIGHT ANGLE. PRODUCT SPEC. APPLICATION SPEC. SIZE A1. CAGE CODE 00779. DRAWING NO. 1825258. WEIGHT. RESTRICTED TO. CUSTOMER DRAWING. SCALE 4:1. SHEET 1 OF 1. REV A2.

X-ON Electronics

Largest Supplier of Electrical and Electronic Components

Click to view similar products for [Slide Switches](#) category:

Click to view products by [TE Connectivity](#) manufacturer:

Other Similar products are found below :

[6-1437581-1](#) [M43R](#) [MHS123K15D](#) [MHS133K](#) [MHSS1104A](#) [MMD](#) [GH49S010001](#) [MSS12A](#) [EPS1PC1](#) [1825074-1](#) [1825160-3](#) [1825167-2](#)
[1825289-7](#) [25139NLDB](#) [25449NAH](#) [SLB1240R45](#) [1825078-1](#) [1825080-4](#) [1825269-1](#) [1825270-2](#) [STS141RA04](#) [T2215BEN506](#)
[GH46P000001](#) [GH46W000001](#) [GH49P010001](#) [25339NA](#) [M42A](#) [TG36P000000](#) [TG36P000050](#) [AYZ0202AG](#) [47227LFE](#) [49331L](#) [50208L](#)
[L203091MS02Q](#) [4-1437581-7](#) [X2225CR-437W](#) [49329L](#) [1101M1S3ZB8E2](#) [1-1437581-1](#) [MSS2225G04](#) [TG39W000000](#) [1825075-1](#)
[MSS42G](#) [TG36WS80065](#) [T105S1CWZBE](#) [SLB124145](#) [SLB1280R5](#) [SLB1340R45](#) [25136NLDB](#) [TG39W000050](#)