

P5100A 500 MHz 100X High Voltage Probe

Instructions



Operating Information

The P5100A Probe is a high impedance probe with 100X attenuation that is designed for use with Tektronix ground-referenced oscilloscopes.

Connect the probe as shown in the illustrations below.

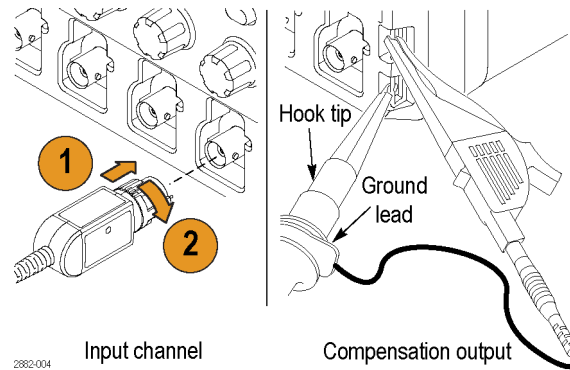

2882-004

Compensating the Probe

Due to variations in oscilloscope input characteristics, the low-frequency compensation of the probe may need adjustment after you move the probe from one oscilloscope channel to another.

1. Connect the probe to the oscilloscope channel that you plan to use for your measurements.
2. Connect the probe to the probe compensation output terminals on the oscilloscope front panel.

⚠ WARNING. To avoid electric shock, only connect to the Probe Comp signal on the oscilloscope when making this adjustment. To avoid electric shock, only use the insulated adjustment tool when making compensation adjustments.

3. Push AUTOSET or otherwise adjust your oscilloscope to display a stable waveform.

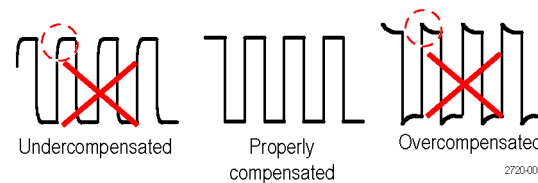

4. Adjust the trimmer in the probe until you see a perfectly flat-top square wave on the display. (See illustration.)

Standard Accessories

The probe includes the accessories shown below.

⚠ WARNING. Do not substitute accessories from other products for use with this probe. Only use the accessories that are included with this probe.

To avoid electric shock when using the probe or accessories, keep your fingers behind the finger guard of the probe body and away from the shaded area shown in the accessory illustrations below.

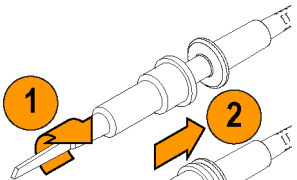
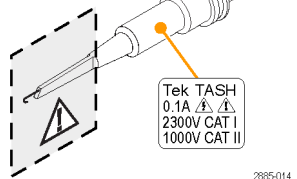
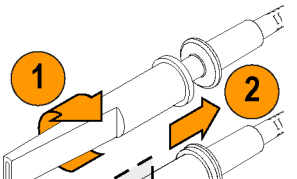
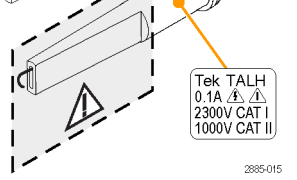
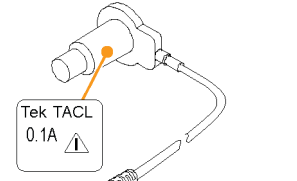
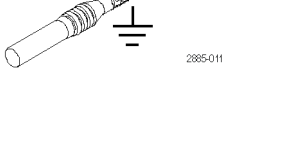
Item	Description
	Small hook tip (TASH) Use this tip to access test points in tight spaces. Screw the hook tip onto the probe tip and then clamp the hook onto the circuit. Rating: 1000 V CAT II Note: Only the 1000 V CAT II rating is applicable when used with the P5100A probe
	Reorder Tektronix part number 013-0388-xx
	Large hook tip (TALH) Screw the hook tip onto the probe tip and then clamp the hook onto the circuit. Rating: 1000 V CAT II Note: Only the 1000 V CAT II rating is applicable when used with the P5100A probe
	Reorder Tektronix part number 013-0389-xx
	Common leads (6 in and 18 in) (TAACL) Slide the lead over the probe head and snap it into place. Connect the banana plug end directly to your circuit common, or use the crocodile clip included with the probe.
	Reorder Tektronix part numbers: 6 inch: 196-3526-xx 18 inch: 196-3527-xx

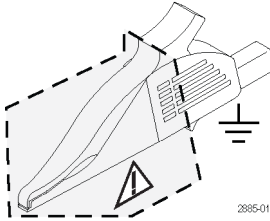
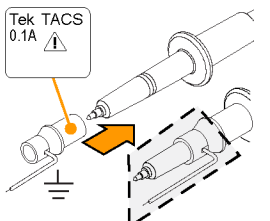
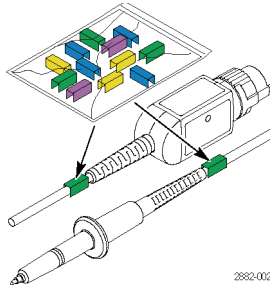
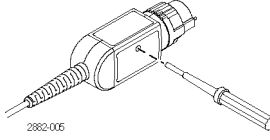
Item	Description
	Crocodile clip Attach the clip to the banana end of the common lead and then to your circuit common. Reorder Tektronix part number 344-0461-xx
	Common spring (TACS) Use this accessory to limit aberrations on high frequency signals caused by common lead path inductance. Bend the spring to reach nearby connections (~1 in). Reorder Tektronix part number 214-5299-xx
	Color bands Use these bands to identify the oscilloscope channel at the probe head. Reorder Tektronix part number 016-1886-xx (5 pairs)
	Adjustment tool Use only this insulated tool for compensation adjustments. Reorder Tektronix part number 003-1433-xx
Optional Accessories	
The accessories shown below are available for the probe and are rated ≤30 V unless indicated otherwise.	
Accessory	Part number
BNC to Tip Adapter, Unterminated	013-0291-xx
Rubber Spring Tip	206-0060-xx
Probe Holder	TPH1000

Service Information

Performance verification and adjustment procedures are available on the Tektronix Web site. Go to www.tektronix.com/manuals and enter P5100A in the search field.

Specifications

Table 1: Electrical and mechanical specifications

System bandwidth (–3 dB, typical)	500 MHz
System rise time (typical)	<700 ps
System input capacitance	2.5 pF
Compensation range	7–30 pF
Propagation delay	~6.1 ns
System attenuation accuracy	100:1 ±1.75%
System input resistance (typical)	40 MΩ ±1%
Cable length	2 m
Maximum input voltage (see <i>Performance Graphs</i>)	1000 V _{RMS} CAT II, 2500 V _{pk}

Performance Graphs

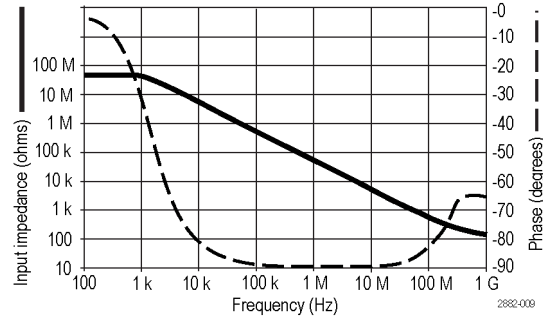
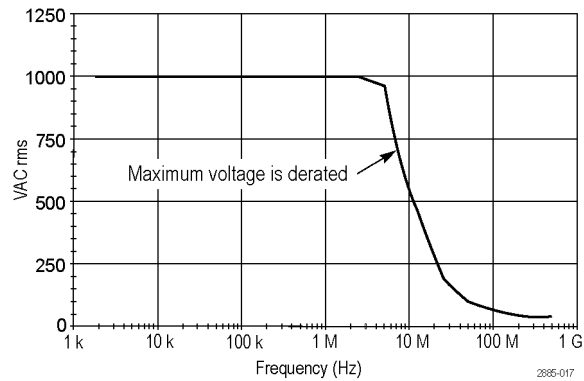
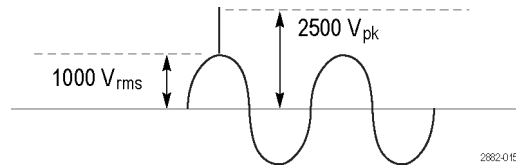

Table 2: Environmental specifications

Characteristics	Description
Temperature	
Operating	0 °C to +50 °C (+32 °F to +122 °F)
Nonoperating	–40 °C to +71 °C (–40 °F to +159.8 °F)
Humidity	
Operating	5% to 95% relative humidity (%RH) up to +30 °C, 5% to 75% RH above +30 °C up to +50 °C. Noncondensing
Nonoperating	5% to 95% RH up to +30 °C 5% to 75% RH above +30 °C to +65 °C 5% to 45% RH above +65 °C up to +71 °C. Noncondensing
Altitude	Operating: up to 3000 m (9842 ft) Nonoperating: up to 15420 m (50,000 ft)

Table 3: Certifications and compliances

Characteristics	Description
EC Declaration of Conformity	Compliance was demonstrated to the following specification as listed in the Official Journal of the European Communities: Low Voltage Directive 2006/95/EC: EN61010-031/A1: 2008
Measurement Category	CAT III: Distribution-level mains, fixed installation
Product Examples	CAT II: Local-level mains, appliances, portable equipment CAT I: Circuits not directly connected to mains.
Pollution Degree 2	Do not operate in environments where conductive pollutants may be present (as defined in IEC 61010-1). Rated for indoor use only.

Characteristics Description

Additional Safety Standards	UL61010-031;2010 CAN/CSA C22.2 No. 61010-031:07/A1:2010 IEC61010-031; IEC 61010-031/A1:2008
-----------------------------	---



Equipment Recycling. This product complies with the European Union's requirements according to Directive 2002/96/EC on waste electrical and electronic equipment (WEEE). For more information about recycling options, check the Support/Service section of the Tektronix Web site (www.tektronix.com).

Safety Summary

Review the following safety precautions to avoid injury and prevent damage to this product or any products connected to it. To avoid potential hazards, use this product only as specified. Using the probe or accessories in a manner not specified could result in a shock or fire hazard.

To Avoid Fire or Personal Injury

Ground-Referenced Oscilloscope Use. Do not float the reference lead of this probe when using with ground referenced oscilloscopes (for example, DPO, MSO, and TDS series oscilloscopes). The reference lead must be connected to earth potential (0 V).

Connect and Disconnect Properly. Connect the probe output to the measurement instrument before connecting the probe to the circuit under test. Disconnect the probe input and the probe reference lead from the circuit under test before disconnecting the probe from the measurement instrument.

Avoid Electric Shock. To avoid injury or loss of life, do not connect or disconnect probes or test leads while they are connected to a voltage source.

Observe All Terminal Ratings. To avoid fire or shock hazard, observe all ratings and markings on the product. Consult the product manual for further ratings information before making connections to the product.

Avoid Electric Shock. When using probe accessories, never exceed the lowest rating of the probe or its accessory, whichever is less, including the measurement category and voltage rating.

Avoid Electric Overload. To avoid injury or fire hazard, do not apply potential to any input, including the reference inputs, that varies from ground by more than the maximum rating for that input.

Avoid Exposed Circuitry and Do Not Operate Without Covers. Do not touch exposed connections and components when power is present.

Inspect The Probe and Accessories. Before each use, inspect probe and accessories for damage (cuts, tears, defects in the probe body, accessories, cable jacket, etc.). Do not use if damaged.

Do Not Operate in Wet/Damp Conditions.

Do Not Operate in an Explosive Atmosphere.

Keep Product Surfaces Clean and Dry.

Safety Terms and Symbols Terms in This Manual.

These terms may appear in this manual:

WARNING. Warning statements identify conditions or practices that could result in injury or loss of life.

CAUTION. Caution statements identify conditions or practices that could result in damage to this product or other property.

Symbols on the Product. These symbols may appear on the product:



Contacting Tektronix

Web site: www.tektronix.com
Phone: 1-800-833-9200
Address: Tektronix, Inc.
Department or name (if known)
14200 SW Karl Braun Drive
P.O. Box 500
Beaverton, OR 97077 USA
Email: techsupport@tektronix.com

Warranty Information

For warranty information, go to www.tektronix.com/warranty.

X-ON Electronics

Largest Supplier of Electrical and Electronic Components

Click to view similar products for [Test Probes](#) category:

Click to view products by [Tektronix](#) manufacturer:

Other Similar products are found below :

[6214](#) [6474](#) [815003](#) [923832-BK-B](#) [P-KIT-1](#) [KT-MS001](#) [925250-R](#) [973368101](#) [972318101](#) [972318100](#) [MXHQ87WJ3000](#) [PK106-3](#) [PK2-5MM-102](#) [TAS90](#) [VL1735/45](#) [973368100](#) [972327100](#) [972327101](#) [973995100](#) [973995101](#) [CT3982B-120](#) [MO50-PINS](#) [CT4386](#) [PP023-1](#) [PK1-5MM-127](#) [PP026-1](#) [PK103](#) [PK-ZS-013](#) [P6139B-PK10](#) [PQ215](#) [PQ218](#) [RT-ZI10C](#) [TT-SI 8071](#) [TT-SI 8050](#) [TT-SI 8010A](#) [TT-SI 7005](#) [GE.3421](#) [GE.2521](#) [GE.3121](#) [GE.1511](#) [GE.1521](#) [GE.2511](#) [GE.4511](#) [HVP15B](#) [TT-SI7002](#) [4005](#) [4011](#) [4012](#) [4013](#) [4014](#)