

Instruction Manual

Tektronix

P6022
Current Probe
070-0948-03

Warning
The servicing instructions are for use by qualified personnel only. To avoid personal injury, do not perform any servicing unless you are qualified to do so. Refer to all safety summaries prior to performing service.

CE

Instrument Serial Numbers

Each instrument manufactured by Tektronix has a serial number on a panel insert or tag, or stamped on the chassis. The first letter in the serial number designates the country of manufacture. The last five digits of the serial number are assigned sequentially and are unique to each instrument. Those manufactured in the United States have six unique digits. The country of manufacture is identified as follows:

B010000	Tektronix, Inc., Beaverton, Oregon, USA
E200000	Tektronix United Kingdom, Ltd., London
J300000	Sony/Tektronix, Japan
H700000	Tektronix Holland, NV, Heerenveen, The Netherlands

Instruments manufactured for Tektronix by external vendors outside the United States are assigned a two digit alpha code to identify the country of manufacture (e.g., JP for Japan, HK for Hong Kong, IL for Israel, etc.).

Tektronix, Inc., P.O. Box 500, Beaverton, OR 97077

Printed in U.S.A.

Copyright © Tektronix, Inc., 1993. All rights reserved. Tektronix products are covered by U.S. and foreign patents, issued and pending. The following are registered trademarks: TEKTRONIX, TEK, TEKPROBE, and SCOPE-MOBILE.

LUBRIPLATE is a registered trademark of the Fiske Brothers Refining Co.

WARRANTY

Tektronix warrants that this product will be free from defects in materials and workmanship for a period of one (1) year from the date of shipment. If any such product proves defective during this warranty period, Tektronix, at its option, either will repair the defective product without charge for parts and labor, or will provide a replacement in exchange for the defective product.

In order to obtain service under this warranty, Customer must notify Tektronix of the defect before the expiration of the warranty period and make suitable arrangements for the performance of service. Customer shall be responsible for packaging and shipping the defective product to the service center designated by Tektronix, with shipping charges prepaid. Tektronix shall pay for the return of the product to Customer if the shipment is to a location within the country in which the Tektronix service center is located. Customer shall be responsible for paying all shipping charges, duties, taxes, and any other charges for products returned to any other locations.

This warranty shall not apply to any defect, failure or damage caused by improper use or improper or inadequate maintenance and care. Tektronix shall not be obligated to furnish service under this warranty a) to repair damage resulting from attempts by personnel other than Tektronix representatives to install, repair or service the product; b) to repair damage resulting from improper use or connection to incompatible equipment; or c) to service a product that has been modified or integrated with other products when the effect of such modification or integration increases the time or difficulty of servicing the product.

THIS WARRANTY IS GIVEN BY TEKTRONIX WITH RESPECT TO THIS PRODUCT IN LIEU OF ANY OTHER WARRANTIES, EXPRESSED OR IMPLIED. TEKTRONIX AND ITS VENDORS DISCLAIM ANY IMPLIED WARRANTIES OF MERCHANTABILITY OR FITNESS FOR A PARTICULAR PURPOSE. TEKTRONIX' RESPONSIBILITY TO REPAIR OR REPLACE DEFECTIVE PRODUCTS IS THE SOLE AND EXCLUSIVE REMEDY PROVIDED TO THE CUSTOMER FOR BREACH OF THIS WARRANTY. TEKTRONIX AND ITS VENDORS WILL NOT BE LIABLE FOR ANY INDIRECT, SPECIAL, INCIDENTAL, OR CONSEQUENTIAL DAMAGES IRRESPECTIVE OF WHETHER TEKTRONIX OR THE VENDOR HAS ADVANCE NOTICE OF THE POSSIBILITY OF SUCH DAMAGES.

Contents

General Safety Summary	iii
Service Safety Summary	v

Operator Information

Description	1
Installation	1
Attaching the Probe and Termination to an Oscilloscope ...	2
Using the Standard Accessories	3
Operating Considerations	4
Features and Controls	4
Insertion Impedance	5
Minimizing Loading Effect	5
Increasing Probe Sensitivity	5
Probe Shielding	6
Droop	6

Service Information

Warranted Characteristics	7
Typical Characteristics	11
Circuit Description	12
Current Probe	12
Termination	12
Performance Verification	14
Adjustment Procedures	16
Preparation	16
Adjust Aberrations	17
Check Sensitivity	19
Check Low Frequency Response	20
Check High Frequency Response	21
Maintenance	22
Cleaning	22
Disassembling the Probe	22
Repairing the Probe	24
Repairing the Termination	24

Replaceable Electrical Parts

Parts Ordering Information	27
Using the Replaceable Parts List	27

Replaceable Mechanical Parts

Parts Ordering Information	33
Using the Replaceable Parts List	33

Index

General Safety Summary

Review the following safety precautions to avoid injury and prevent damage to this product or any products connected to it.

Only qualified personnel should perform service procedures.

Injury Precautions

Avoid Electric Overload

To avoid injury or fire hazard, do not apply potential to any input, including the common inputs, that varies from ground by more than the maximum rating for that input.

Do Not Operate Without Covers

To avoid electric shock or fire hazard, do not operate this product with covers or panels removed.

Do Not Operate in Wet/Damp Conditions

To avoid electric shock, do not operate this product in wet or damp conditions.

Do Not Operate in an Explosive Atmosphere

To avoid injury or fire hazard, do not operate this product in an explosive atmosphere.

Product Damage Precautions

Do Not Operate with Suspected Failures

If you suspect there is damage to this product, have it inspected by qualified service personnel.

Do Not Immerse in Liquids

Clean the probe using only a damp cloth. Refer to cleaning instructions.

Safety Terms and Symbols

Terms in This Manual

These terms may appear in this manual:

WARNING

Warning statements identify conditions or practices that could result in injury or loss of life.

CAUTION

Caution statements identify conditions or practices that could result in damage to this product or other property.

Terms on the Product

These terms may appear on the product:

DANGER indicates an injury hazard immediately accessible as you read the marking.

WARNING indicates an injury hazard not immediately accessible as you read the marking.

CAUTION indicates a hazard to property including the product.

Symbols on the Product

The following symbols may appear on the product:



DANGER
High Volt-
age



Protective
Ground (Earth)
Terminal



ATTENTION
Refer to Manual



Double
Insulated

P6022 Current Probe

Service Safety Summary

Only qualified personnel should perform service procedures. Read this *Service Safety Summary* and the *General Safety Summary* before performing any service procedures.

Do Not Service Alone

Do not perform internal service or adjustments of this product unless another person capable of rendering first aid and resuscitation is present.

Operator Information

Thank you for choosing a Tektronix current probe. This manual describes the P6022 current probe with passive termination, and provides information about making measurements with the probe.

Description

The P6022 current probe converts an alternating current waveform to a voltage that can be displayed and measured on an oscilloscope display. It provides accurate current measurements over a wide range of frequencies, and allows you to measure current without breaking the circuit.

The P6022 probe is compatible with general purpose oscilloscopes having a 1 M Ω input impedance. The P6022 probe comes with a passive termination that matches oscilloscope and probe impedance, optimizes the probe performance, and provides two sensitivity settings.

In the standard configuration, the P6022 probe comes with a 5-foot cable and termination. The following option is also available.

Option 03 — 9-foot cable with termination

Installation

This section describes both attaching the probe to an oscilloscope and using the standard accessories with the probe.

To ensure the best performance from your probe/oscilloscope measurement system, check that the probe and oscilloscope are appropriately matched. The oscilloscope inputs should use BNC connectors, and have an impedance of 1 M Ω .

Figure 1 shows the probe and various parts referred to in this manual.

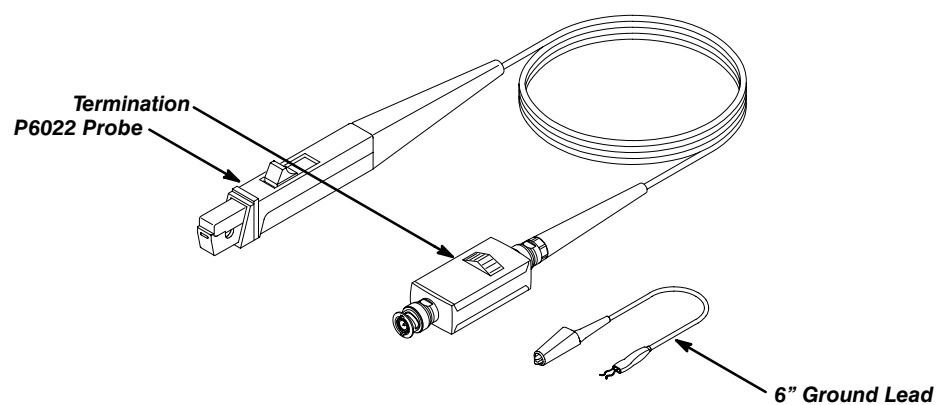

Figure 1: The P6022 Probe and Termination

Attaching the Probe and Termination to an Oscilloscope

Attach the probe to the termination as shown in Figure 1.

A 6-inch ground lead is supplied to improve EMI rejection at high frequencies (2 MHz and above). Snap the ground lead to the probe transformer post and attach the alligator clip directly to RF ground. This will reduce ringing and help bypass capacitively-coupled RF currents which can flow into the probe cable.

CAUTION

To avoid damaging the probe, do not disconnect the probe termination and leave the P6022 clamped around the conductor when measuring high currents. Leaving the probe cable unterminated can cause a high voltage to develop in the secondary winding which may damage the current probe transformer.

WARNING

When the probe slides are open, the exposed ferrite core pieces are not insulated. To avoid injury or equipment damage, remove power from an uninsulated wire before clamping the current probe around it. Also, never disconnect the probe from the termination when the probe is connected to a live conductor.

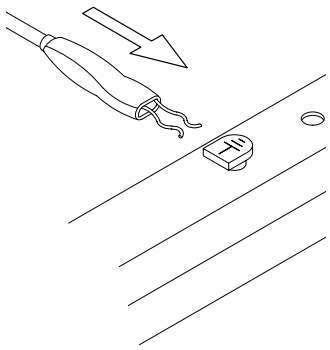

Using the Standard Accessories

Your P6022 is shipped with the following accessories:

- **This instruction manual** — Read these instructions to familiarize yourself with the features, specifications, and operation of the P6022 current probe.
- **6-inch ground lead** — Use the 6-inch ground lead to ground the shield around the probe transformer at the probe end of the cable. This allows you to move the ground connection closer to the circuit you are measuring, thereby improving high frequency response. The ground lead clips onto the ground connector on the bottom of the probe as shown.

Please refer to the parts list in the section entitled *Replaceable Mechanical Parts* for part numbers.

Operating Considerations

The information in this section will help you make the most effective use of your P6022 probe.

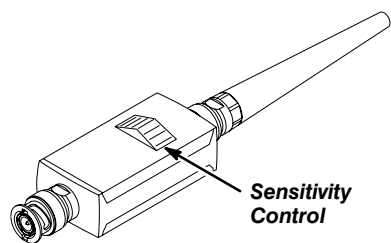

Features and Controls

- **Sensitivity Control** — The P6022 termination has a control that allows you to select probe sensitivity. The switch has two positions: 1 mA/mV and 10 mA/mV. When the control is in the 1 mA/mV position, the oscilloscope displays 1 mV for every 1 mA of current in the circuit under test. When the control is in the 10 mA/mV position, the oscilloscope displays 1 mV for every 10 mA of current in the circuit under test.

You can set vertical scale on the oscilloscope to any scale factor, as determined by the signal amplitude. To calculate the overall vertical scale factor for the oscilloscope, probe, and termination, multiply the termination sensitivity control setting by the vertical scale factor of the oscilloscope. For example, if the termination control is set to the 10 mA/mV position, and the oscilloscope to a vertical scale of 20 mV/division, the overall scale factor is 10 X 20, or 200 mA/division.

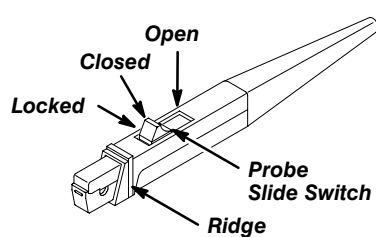

- **Probe Slide Switch** — The slide switch on the probe has three positions: open, closed, and locked. Use your thumb to move the probe slide switch. The switch is spring-loaded so that it automatically moves from the open to closed positions.

To Use the Probe:

- a. Pull the slide switch toward you and hold the switch in position.
- b. Place the conductor-under-test inside the exposed transformer core. The arrow on the transformer end of the probe indicates conventional current flow. If you place the probe on the conductor so that the arrow on the probe matches conventional current flow through the conductor, orientation of the displayed waveform will be correct.
- c. Release the switch, allowing the probe to close.
- d. Lock the slide switch. To lock the switch, push it firmly toward the transformer (the switch will move only about 1/8th inch). Locking the switch assures maximum contact between the two halves of the transformer secondary. The conductor now becomes the primary of the transformer. (When measuring current, always check that the probe slide switch is moved completely forward into the locked position.)

WARNING

To prevent shock when measuring uninsulated conductors, keep your hands and fingers behind the ridge on the probe head.

Insertion Impedance

When you insert a conductor into the probe, you add impedance to the circuit you are measuring. This additional impedance affects signals; this is particularly important if you are measuring fast rise times. Figure 2 illustrates the equivalent circuit with additional impedance introduced by the P6022.

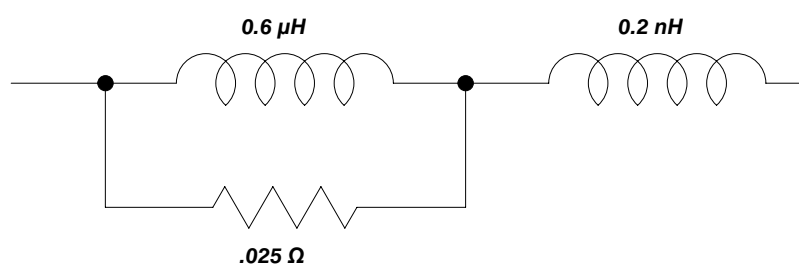

Figure 2: Insertion Impedance of the P6022

Minimizing Loading Effect

To minimize the loading effect of the probe, clamp it at the low or ground end of a component lead when possible. This method also minimizes noise or stray signal interference.

Increasing Probe Sensitivity

You can increase the current sensitivity of the probe by increasing the number of times a conductor passes through it. For example, if the conductor loops through the probe twice (a two-turn primary winding), the secondary current is doubled, because the ratio of current in a transformer is inversely proportional to the turns ratio.

For example, suppose you set the termination sensitivity to 1 mA/mV and the oscilloscope vertical scale to 10 mV/division. Ordinarily, this would result in the equivalent of 1 X 10, or 10 mA/division. However, if the conductor is looped through the probe twice, the vertical scale is divided by two, resulting in the equivalent of 5 mA/division.

Looping the conductor twice effectively doubles vertical sensitivity; however, impedance from the probe winding is also reflected into the circuit being measured. This impedance varies as the square of the number of loops. This additional impedance affects signals; this effect is particularly important when you are measuring high-frequency current waveforms or waveforms with fast rise times.

Probe Shielding

The P6022 is shielded to minimize the effect of external magnetic fields. However, strong fields can interfere with the current signal being measured. If you suspect that an external field is interfering with your measurement, remove the probe from the conductor, but keep it in the same location as when you made the suspect measurement. If a signal still appears on the oscilloscope, try to measure the conductor current at a point farther from the location of the magnetic field.

If you must measure current in the presence of a strong magnetic field, you can minimize its interference by using two current probes and a differential-input oscilloscope. To do so, follow these steps.

1. Connect the probes (with termination) to the positive and negative inputs of the oscilloscope.
2. Clamp one probe around the conductor whose current you wish to measure.
3. Place the other probe as close as possible to the first. Ensure that its slide switch is completely closed, without a conductor inside it.
4. Set the oscilloscope to subtract the component of the signal that is common to both probes.
5. Adjust the positions of the probes for best results. It may be difficult to eliminate the undesirable signal completely, due to differences between the probes or their terminations.

Droop

The flat-top response of any AC current probe displays a certain amount of droop. This is caused by probe inductance loading the source impedance, causing an L/R exponential decay. For short pulse widths, the response looks nearly flat. The amount of droop can be calculated from the following relationship:

$$\% \text{ Droop} = 200 (\pi) T f$$

where:

T=pulse duration

f=lower 3 dB frequency of probe

Service Information

Warranted Characteristics

This section lists the various warranted characteristics that describe the P6022 Current Probe. Included are warranted electrical and environmental characteristics.

Warranted characteristics are described in terms of quantifiable performance limits which are warranted.

The electrical characteristics listed in Table 1 apply under the following conditions:

- The probe and instrument with which it is used must have been calibrated at an ambient temperature of between +20°C and +30°C.
- The probe and instrument must be in an environment whose limits are described in Table 2.

Table 1: Warranted Electrical Characteristics

Characteristic	Information
Sensitivity	1 mA or 10 mA for each mV at oscilloscope input, selected by termination sensitivity control
Midband Accuracy	±3%
Bandwidth (with BW>200 MHz oscilloscope)	
1 mA/mV	8.5 kHz to 100 MHz
10 mA/mV	935 Hz to 120 MHz
Step Response	<i>Because the oscilloscope input capacitance becomes a part of the termination network, the step response will vary with different oscilloscopes</i>
Aberrations (probe and termination at either sensitivity setting.)	≤10% peak-to-peak within 25 ns of step; ≤2% peak-to-peak thereafter

Table 2: Warranted Environmental Characteristics

Characteristic	Information
Temperature range:	
Operating	-0°C to +50°C
Nonoperating	-40°C to +65°C
Altitude	
Operating	To 2,000 m (6,561 ft), <300 V CAT I To 4,572 m (15,000 ft), <150 V CAT II
Nonoperating	To 15,240 m (50,000 ft)

Table 3: Maximum Ratings

Characteristic	Information
Maximum continuous (CW) current	Refer to Figure 3 for frequency derating curves
1 mA/mV	6 A _{p-p} sine wave between 10 kHz and 10 MHz
10 mA/mV	6 A _{p-p} sine wave between 3 kHz and 10 MHz
	Refer to Figure 3 for frequency derating curves
Maximum pulse current	100 A peak, not to exceed 9(A · μs) or 2 A _{RMS} . An (A · s) product greater than 9(A · μs) reduces probe output to zero due to core saturation
Maximum Working Input Voltage (uninsulated conductors)	300 VAC or VDC, CAT I, and 600 V _{pk} limited to <10 ms and <25% duty factor.

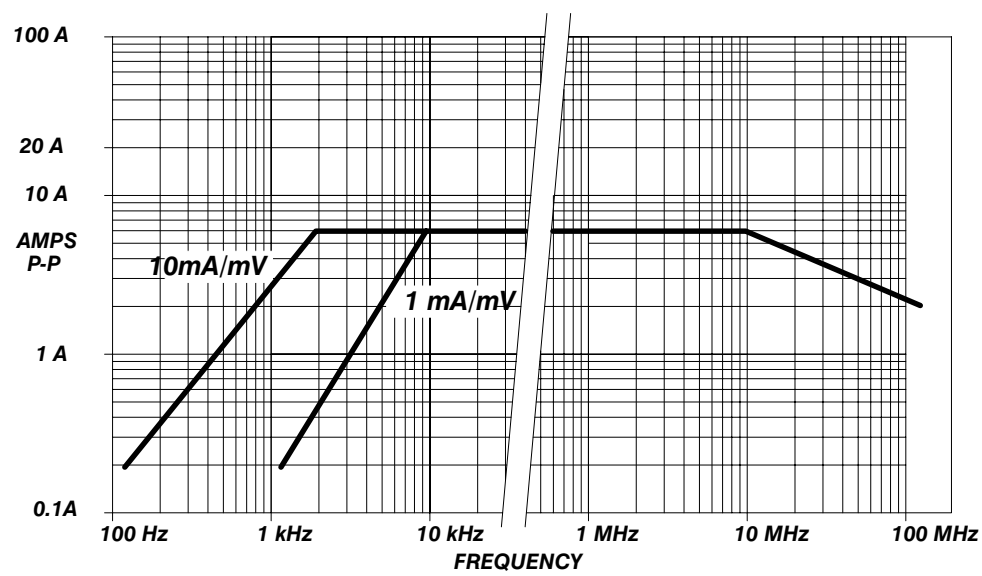

Figure 3: Probe and Termination Input Current vs. Frequency Derating

Table 4: Certifications and Compliances

EC Declaration of Conformity – Low Voltage

Compliance was demonstrated to the following specifications as listed in the Official Journal of the European Communities:

Low Voltage Directive 73/23/EEC, as amended by 93/68/EEC

EN 61010-1/A2	Part 1: General Requirements Safety requirements for electrical equipment for measurement, control, and laboratory test
---------------	--

EN 61010-2-032:1995	Part 2-032: Particular requirements for hand-held current clamps for electrical measurements and test
---------------------	--

Table 4: Certifications and Compliances (Cont.)

Installation Category Descriptions	
Terminals on this product may have different installation category designations. The installation categories are:	
CAT III	Distribution-level mains (usually permanently connected). Equipment at this level is typically in a fixed industrial location
CAT II	Local-level mains (wall sockets). Equipment at this level includes appliances, portable tools, and similar products. Equipment is usually cord-connected
CAT I	Secondary (signal level) or battery operated circuits of electronic equipment

Pollution Degree 2	Do not operate in environments where conductive pollutants may be present.
--------------------	--

Typical Characteristics

This section lists the various typical characteristics that describe the P6022 Current Probe. Included are typical electrical and mechanical characteristics.

Typical characteristics are described in terms of typical or average performance. Typical characteristics are not warranted.

Table 5: Electrical Characteristics

Characteristic	Information
Tilt	
1 mA/mV	4% or less within 1 μ s of step
10 mA/mV	4% or less within 10 μ s of step
Maximum DC without saturation	0.2 A
Signal delay	
5-foot probe with termination	Approximately 9 ns
9-foot probe with termination	Approximately 15.8 ns
Insertion impedance	0.03 Ω or less at 1 MHz, increasing to 0.2 Ω or less at 120 MHz

Table 6: Mechanical Characteristics

Characteristic	Information
Probe cable length	5 ft or 9 ft 1.5 m or 2.75 m
Net weight:	
Probe and 5-foot cable	2.5 oz \approx 71 gm
Probe and 9-foot cable	3.2 oz \approx 93 gm
Termination	1.7 oz \approx 48 gm
Termination	L 3.47" 88 mm W 1.10" 28 mm H 0.86" 22 mm
Probe Body	L 6.0" 152 mm W 0.4" 10 mm H 0.6" 15 mm
Maximum Conductor Diameter	0.141" 3.58 mm

Circuit Description

This section describes the circuits in the P6022 current probe and termination. For the schematic diagram of the probe and termination, see Figure 4 on page 13.

Current Probe

The P6022 current probe consists of a current transformer mounted in the nose of the probe head case, an impedance-matching network, and an internal switch to disconnect the transformer shield from ground.

The transformer contains a two-section U-shaped ferrite core. One section is stationary; the other is mechanically movable to permit closing the core around the conductor being measured. The conductor under test forms a one-turn primary winding for the transformer; the windings around the stationary portion of the core are the secondary windings. Paralleled windings in the secondary assure a fast step response. The circuitry between the transformer and the coaxial cable corrects any differences in level between the pulses induced in the paralleled windings of the secondary, and matches the balanced probe winding to the cable.

As indicated on the probe body, the turns ratio of the P6022 is 50:1. This refers to the number of windings in the secondary of the probe transformer.

The probe transformer is shielded to eliminate interference from outside signals. To eliminate the possibility of creating a short circuit from this shield to the conductor being measured, the slide switch disconnects the ground from the shield when you open the sliding portion of the probe to connect or remove it from a conductor.

Termination

The P6022 termination consists of a 62.5 Ω impedance-matching network to terminate the coaxial cable, and a voltage divider that is switched in by a sensitivity control to change the sensitivity by a factor of five. When the control is in the 1 mA/mV position, a 10 mA current signal in the conductor under test induces a 10 mV signal at the output of the termination. (This assumes that the termination is connected to a 1 M Ω input oscilloscope.)

When the sensitivity control is in the 10 mA/mV position, a 10 mA current signal is attenuated to induce a 1 mV signal at the output of the termination.

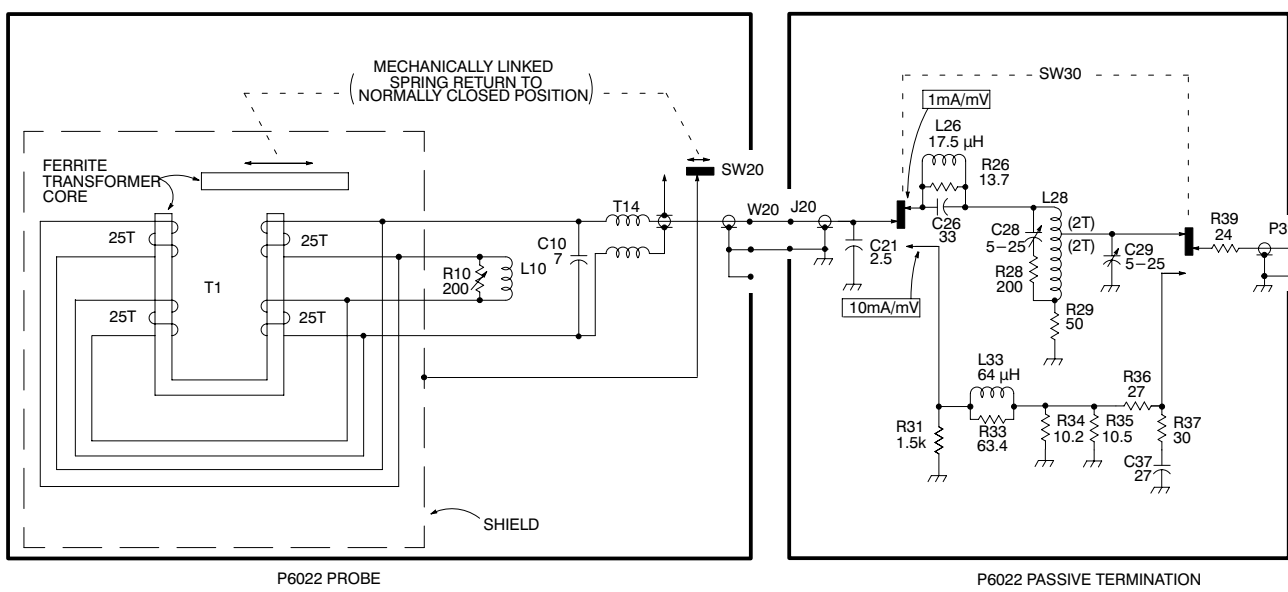

Figure 4: P6022 Schematic Diagram

Performance Verification

WARNING

This probe should be serviced only by qualified service personnel.

To avoid personal injury and damage to the probe, remove the probe from any signal source before attempting to adjust or service the probe.

Do not service electrical equipment alone. If you must service or adjust equipment that is attached to a signal or power source, do so only when another person capable of rendering first aid and resuscitation is present.

This section provides procedures to check the performance of the P6022, or to calibrate it. These procedures require the equipment listed in Table 7. Specifications given are the minimum necessary for accuracy. If equipment is substituted, it must meet or exceed the specifications of the recommended equipment. Test equipment is assumed to be correctly calibrated and operating within the given specifications.

Also, if equipment is substituted, control settings or equipment setup may need to be altered. For detailed operating instructions for the test equipment, refer to the instruction manual for each unit.

To ensure measurement accuracy, check the performance of the probe and termination whenever you begin using them with a different oscilloscope input, especially when you have changed input capacitance. Recalibrate the probe if necessary. Also check the calibration of the probe and termination every 1000 hours of operation, or every six months if they have been used infrequently.

Before calibrating the probe, inspect and clean it thoroughly as described in the section entitled *Maintenance*. Dirty or worn mating surfaces between the transformer and the lid can degrade low-frequency response. Clean these surfaces if necessary.

Calibration procedures can also be used as performance checks by completing all steps except those that adjust the probe. This checks the probe and termination to the original performance standards without requiring you to remove the termination cover or make internal adjustments.

Table 7: Equipment List

Item	Description	Recommended Equipment
Oscilloscope		TDS 360
Bandwidth	DC to 200 MHz	
Vertical sensitivity	1 mV/div	
Calibration generator		Tektronix PG506A Calibration Generator
Fast rise time	Risetime ≤ 1 ns 1 V _{p,p} into 50 Ω	
Function generator / low frequency oscillator		Tektronix FG 501A Function Generator
Frequency range	935 Hz to 50 kHz	
Output amplitude	3 V _{p,p} into 50 Ω	
Amplitude accuracy	$\pm 3\%$ of reference at 50 kHz	
Sine wave generator		Tektronix SG 503 Leveled Sine Wave Generator
Frequency range	250 kHz to 150 MHz	
Output amplitude	3 V _{p,p} into 50 Ω	
Amplitude accuracy	$\pm 1\%$ from 250 kHz to 150 MHz	
Termination, feedthrough BNC	50 Ω	Tektronix Part No. 011-0049-01
Attenuator, BNC	5X, 50 Ω	Tektronix Part No. 011-0060-02
Attenuators, BNC	10X, 50 Ω	Tektronix Part No. 011-0059-02
Coaxial cable	36-inch, 50 Ω precision	Tektronix Part No. 012-0482-00
Adapter	BNC male to GR	Tektronix Part No. 017-0064-00
Fixture	Current probe, calibration	Tektronix Part No. 067-0559-00

Adjustment Procedures

Preparation

1. Insert a small screwdriver between the cover and the termination near the part number, and gently pry up the top cover only from the P6022 termination by twisting the screwdriver. Leave the bottom cover on, as it must remain in place whenever the termination is in use.

2. Set up the oscilloscope as described below:

Vertical mode	CH 1
Horizontal mode	Main
Trigger source	CH 1
Trigger coupling	AC
Trigger mode	Peak-to-peak, auto
Trigger slope	Positive
Trigger level	As required
Ch 1 coupling	DC
Volts/division	2 mV
Time/division	5 ns
Averages	5 to 10

NOTE

When using a digitizing oscilloscope, set "averaging" on to increase resolution.

3. Set up the calibration generator as described below:

Output	1 V _{p-p}
Repetition rate	≥10 kHz

4. Set up the function generator as described below:

Frequency	5
Offset	Off
Amplitude	50%
Frequency vernier	Cal
Multiplier	10 ⁴
Function	Sine wave

5. Set up the sine wave generator as described below:

Frequency	REF (50 kHz)
-----------	--------------

Adjust Aberrations



To avoid damaging the probe, do not disconnect the probe termination when measuring high currents. Leaving the probe cable unterminated can cause a high voltage to develop in the secondary winding which may damage the current probe transformer.

- Step 1:** Connect the current probe calibration fixture to the PG506A calibration generator –1/+0 output using the appropriate adapter.
- Step 2:** Set the calibration generator to Fast Rise.
- Step 3:** Connect the P6022 cable BNC connector to the termination.
- Step 4:** Connect the P6022 termination to the oscilloscope Ch 1 input.
- Step 5:** Set the P6022 termination sensitivity to 1 mA/mV.
- Step 6:** Pulling back on the probe slide switch, connect the probe to the current probe calibration fixture.

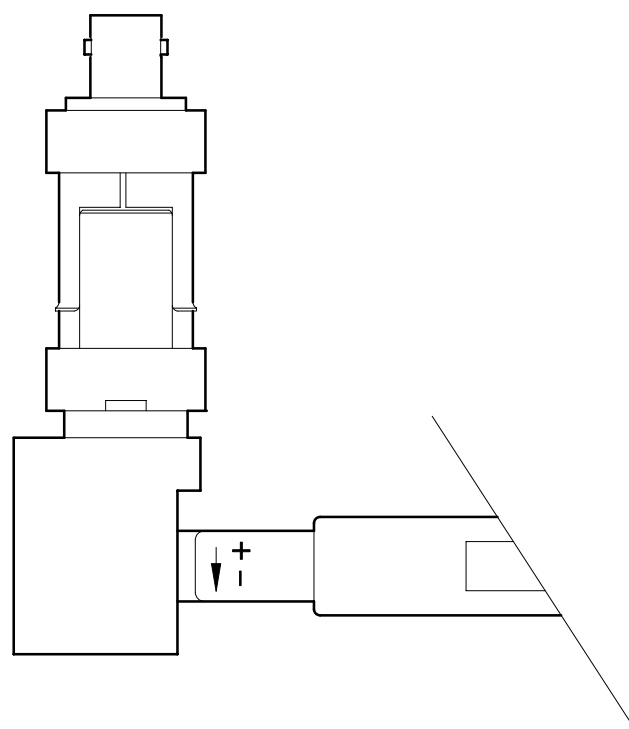

Figure 5: Connecting the Probe to the Calibration Fixture

Ensure that the current is flowing in the correct direction; the minus sign should be near the outside and the plus sign should be near the connectors, as shown in Figure 5. (The figure shows the probe slide switch held open so that the plus and minus signs are visible. When you close the probe, the front portion with the markings will disappear inside the calibration fixture.)

- Step 7:** Turn on the test equipment.
- Step 8:** Adjust the oscilloscope position, triggering, intensity, and calibration generator amplitude controls until the signal is centered on the display across five vertical divisions.
- Step 9:** Check the first 25 nanoseconds of step for aberrations $\leq 10\%_{p-p}$. After the first 25 nanoseconds, check for aberrations $\leq 2\%_{p-p}$.
- Step 10:** If required, adjust C28 and C29 (in the termination), and then R10 (through the hole in the probe handle) to bring the probe into compliance with step 9.
- Step 11:** Set the termination sensitivity control to the 10 mA/mV position.
- Step 12:** Set the oscilloscope vertical deflection to 1 mV/division.
- Step 13:** Adjust the oscilloscope position, triggering, intensity, and calibration generator amplitude controls until the signal is centered on the display. Make certain that you can see the top of the waveform.
- Step 14:** Check again to make sure that the aberrations are within the specifications described in Step 9. Repeat any adjustments required.

NOTE

Aberration characteristics do not include the effects of the test oscilloscope.

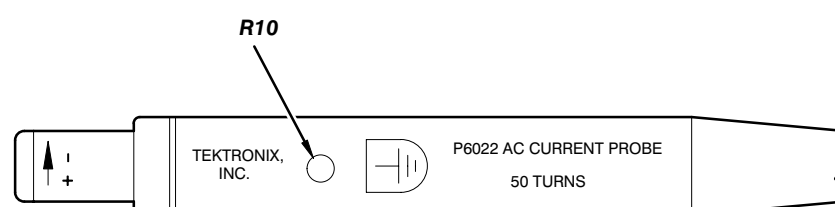

Figure 6: Location of Probe Adjustments

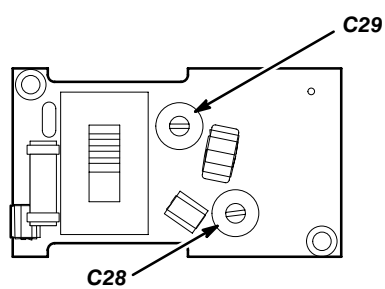

Figure 7: Location of Termination Adjustments

Check Sensitivity

- Step 1:** Set the oscilloscope time/division to 10 μ s.
- Step 2:** Set the oscilloscope vertical deflection to 10 mV/div.
- Step 3:** Check that the P6022 termination sensitivity is set to 1 mA/mV.
- Step 4:** Disconnect the P6022 termination from the oscilloscope.
- Step 5:** Connect a 50 Ω cable with the 10X and 5X attenuators terminated through 50 Ω to the oscilloscope.
- Step 6:** Connect the other end of the cable to the FG 501A function generator.
- Step 7:** Adjust the amplitude of the function generator output until it is six divisions tall on the oscilloscope display.
- Step 8:** Disconnect the cable and attenuators from the oscilloscope and function generator.
- Step 9:** Connect the P6022 probe and termination to the oscilloscope.
- Step 10:** Connect the calibration fixture to the output of the FG 501A function generator.
- Step 11:** Check that the function generator output is still six divisions tall on the oscilloscope display, $\pm 3\%$ (excluding attenuator error).

NOTE

The attenuators you use should be calibrated so that you can determine their error.

Check Low Frequency Response

- Step 1:** Connect the current probe calibration fixture to the FG 501A function generator output using the appropriate adapter.
- Step 2:** Connect the probe to the current probe calibration fixture.
- Step 3:** Set the termination sensitivity to 1 mA/mV.
- Step 4:** Set the function generator for a 50 kHz sine wave output.
- Step 5:** Turn on the test equipment.
- Step 6:** Adjust the amplitude of the function generator output until it is six divisions tall on the oscilloscope display.
- Step 7:** Lower the function generator frequency until the signal amplitude is 4.2 divisions. Adjust the oscilloscope timebase as necessary.
- Step 8:** Check that the function generator frequency is ≤ 8.5 kHz.
- Step 9:** Reset the function generator frequency to 50 kHz.
- Step 10:** Reset the oscilloscope time/division to 10 μ s.
- Step 11:** Set the termination sensitivity to 10 mA/mV.
- Step 12:** Set the oscilloscope vertical deflection to 1 mV/division.
- Step 13:** Adjust the amplitude of the function generator output until it is six divisions tall on the oscilloscope display.
- Step 14:** Lower the function generator frequency until the signal amplitude is 4.2 divisions. Adjust the oscilloscope timebase as necessary.
- Step 15:** Check that the function generator frequency is ≤ 935 Hz.

NOTE

Dirty or worn mating surfaces between the transformer and the lid degrade the low-frequency response. Clean them if necessary. See page 19 for cleaning instructions.

Check High Frequency Response

- Step 1:** Connect the current probe calibration fixture to the SG 503 Sine Wave Generator output using the appropriate adapters.
- Step 2:** Connect the probe to the current probe calibration fixture.
- Step 3:** Ensure that the termination sensitivity is set to 10 mA/mV.
- Step 4:** Set the oscilloscope vertical deflection to 1 mV/division.
- Step 5:** Set the oscilloscope time per division to 10 μ s.
- Step 6:** Set the sine wave generator frequency to 50 kHz.
- Step 7:** Adjust the amplitude of the sine wave generator output until it is six divisions tall on the oscilloscope display.
- Step 8:** Increase the sine wave generator frequency until the signal amplitude is 4.2 divisions. (Adjust the oscilloscope timebase as necessary.)
- Step 9:** Check that the frequency of the sine wave generator is ≥ 120 MHz on the oscilloscope display. (If you are using an oscilloscope with a bandwidth less than 200 MHz, the response may be < 120 MHz.)
- Step 10:** Reset the sine wave generator frequency to 50 kHz.
- Step 11:** Reset the oscilloscope time per division to 10 μ s.
- Step 12:** Decrease the amplitude of the sine wave generator output until the amplitude is one division tall.
- Step 13:** Set the oscilloscope vertical deflection to 10 mV/division.
- Step 14:** Set the termination sensitivity to 1 mA/mV.
- Step 15:** Adjust the amplitude of the sine wave generator output until it is six divisions tall on the oscilloscope display.
- Step 16:** Increase the sine wave generator frequency until the signal amplitude is 4.2 divisions. (Adjust the oscilloscope timebase as necessary.)
- Step 17:** Check that the sine wave generator frequency is ≥ 100 MHz. (If you are using an oscilloscope with a bandwidth < 200 MHz, the response may be < 100 MHz.)

When you are done, disconnect all test equipment and replace the termination cover.

Maintenance

The information in this section will help you maintain your probe for a long service life.

Cleaning

To clean the probe body, use a soft cloth dampened in a solution of mild detergent and water. To clean the core, open the jaw and clean the exposed core surfaces with a cotton swab dampened with isopropyl alcohol (isopropanol) or ethyl alcohol (fotocol or ethanol).



To prevent damage to probe materials, avoid using chemicals that contain benzene, benzine, toluene, xylene, acetone, or similar solvents.

Do not immerse the probe in liquids or use abrasive cleaners.

Do not lubricate the jaws mating surfaces. Any lubricant between the core pieces should be removed with a recommended solvent.

Do not use a petroleum based lubricant on the plastic. If the plastic slide assembly requires lubrication, use a silicone based grease sparingly.

When cleaning the probe, look for any excessive wear of the slide parts that might cause the probe to operate improperly. Dirty or worn mating surfaces between the transformer and the lid can degrade low-frequency response. Clean these surfaces if necessary.

Disassembling the Probe

Use the following procedure to disassemble the probe for cleaning or repair. You will need a low power soldering iron with a fine point. Work over a smooth, clean surface so that you can easily find any small pieces that may drop. Refer to Figure 8.

CAUTION

To avoid degrading the probe's performance, do not touch the polished mating surfaces of the transformer after cleaning.

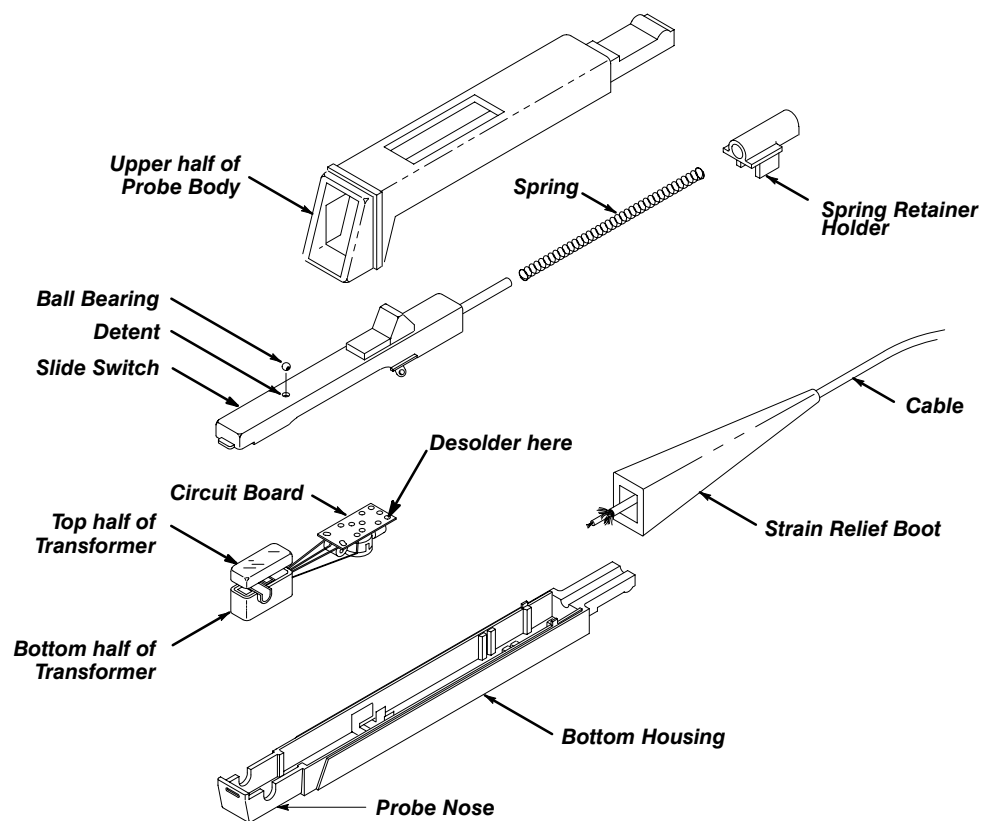

Figure 8: Disassembling the Probe

- Step 1:** Hold the probe horizontally with the slide switch up.
- Step 2:** Pull the strain relief boot back over the cable. Lightly rock the strain relief boot from side to side as you pull back on it.
- Step 3:** Be careful, there is a spring-loaded retainer and a small ball bearing you are about to expose.
- Step 4:** Slowly lift the upper half of the probe body slightly at the cable end and push the assembly forward over the nose and off.
- Step 5:** Remove the small ball bearing from the detent in the slide switch.

- Step 6:** Lift the back of the return spring retainer out of the holder.
- Step 7:** Remove the slide switch, spring retainer, and the top of the transformer as a unit. Notice the orientation of the movable portion of the transformer in the slide.



When applying heat to the soldered connection, use only enough heat for as long as necessary. Excess heat may cause irreparable damage to the circuit board.

- Step 8:** Desolder the ground connection on the circuit board. See Figure 8.
- Step 9:** Lift the circuit board, transformer, and cable out of the probe body as a unit. Be careful, the cable connection to the board is fragile and may break if not handled gently.
- Step 10:** To reassemble the probe, reverse the procedure above.
When replacing the slide switch, spring retainer, and transformer top as a unit, push the slide switch contacts gently inside the sides of the bottom housing.

Repairing the Probe

To make repairs inside the probe body, disassemble the probe as described in the previous section. If you need to solder on the circuit board, use a minimum of heat and observe normal circuit board procedures.

If you need to replace the current transformer, replace the entire assembly including the other half of the transformer core mounted in the slide switch. The transformer halves are matched at the factory before shipment.

Repairing the Termination

Repairing the termination can consist of replacing either the connectors or the circuit board. These tasks are described below.

Replacing the Connectors — To replace the connectors, follow these steps.

- Step 1:** Insert a small screwdriver between the cover and the termination near the part number, and gently pry up the plastic snap-on cover from the termination.
- Step 2:** Using a heat sink, unsolder the leads from the defective connector.

- Step 3:** Unscrew and remove the defective connector.
- Step 4:** Replace the defective connector with the new one.
- Step 5:** Screw and solder the new connector back in place.
- Step 6:** Align the switch with the slider in the front cover and replace the front cover.

Replacing the Circuit Board — To replace the circuit board, follow these steps.

- Step 1:** Remove the plastic snap-on covers from the front and back of the termination.
- Step 2:** Using a heat sink, unsolder the leads from the connectors.
- Step 3:** Unscrew the two screws from the back of the circuit board.
- Step 4:** Remove the circuit board from the termination and repair it as you require, being careful to use a minimum of heat and observe normal circuit board procedures.
- Step 5:** Replace the circuit board by reversing the above procedure.
- Step 6:** Align the switch with the slider in the front cover and replace the front cover.

Replaceable Electrical Parts

Parts Ordering Information

Replacement parts are available from or through your local Tektronix, Inc. service center or representative.

Changes to Tektronix instruments are sometimes made to accommodate improved components as they become available and to give you the benefit of the latest circuit improvements. Therefore, when ordering parts, it is important to include the following information in your order:

- Part number
- Instrument type or model number
- Instrument serial number
- Instrument modification number, if applicable

If a part you order has been replaced with a different or improved part, your local Tektronix service center or representative will contact you concerning any change in the part number.

Change information, if any, is located at the rear of this manual.

Using the Replaceable Parts List

The tabular information in the Replaceable Parts List is arranged for quick retrieval. Understanding the structure and features of the list will help you find the all the information you need for ordering replacement parts.

Item Names

In the Replaceable Parts List, an Item Name is separated from the description by a colon (:). Because of space limitations, an Item Name may sometimes appear as incomplete. For further Item Name identification, U.S. Federal Cataloging Handbook H6-1 can be used where possible.

Abbreviations

Abbreviations conform to American National Standards Institute (ANSI) standard Y1.1

List of Assemblies

A list of assemblies can be found at the beginning of the electrical parts list. The assemblies are listed in numerical order. When the complete component number of a part is known, this list will identify the assembly in which the part is located.

Cross Index-Mfr. Code Number to Manufacturer

The Mfg. Code Number to Manufacturer Cross Index for the electrical parts list is located immediately after this page. The cross index provides codes, names, and addresses of manufacturers of components listed in the electrical parts list.

Component Number (column 1 of the parts list)

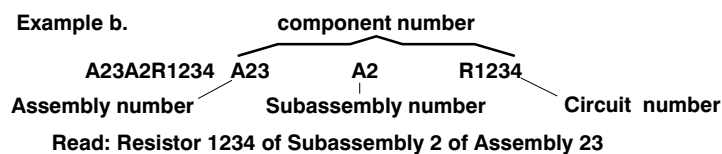
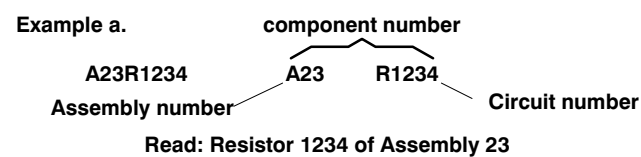

The circuit component's number appears on the diagrams and circuit board illustrations. Each diagram and circuit board illustration is clearly marked with the assembly number. Assembly numbers are also marked on the mechanical exploded views located in the mechanical parts list. The component number is obtained by adding the assembly number prefix to the circuit number.

The electrical parts list is divided and arranged by assemblies in numerical sequence (e.g., assembly A1 with its subassemblies and parts, precedes assembly A2 with its subassemblies and parts).

Chassis-mounted parts have no assembly number prefix and are located at the end of the electrical parts list.

Tektronix Part No. (column 2 of the parts list)

Indicates part number to be used when ordering replacement part from Tektronix.

Serial No. (columns 3 & 4 of the parts list)

Column three (3) indicates the serial number at which the part was first used. Column four (4) indicates the serial number at which the part was removed. No serial number entered indicates part is good for all serial numbers.

Name & Description (column five of the parts list)

In the parts list, an item name is separated from the description by a colon (:). Because of space limitations, an item name may sometimes appear as incomplete. For further item name identification, the U.S. Federal Catalog handbook H6-1 can be utilized where possible.

Mfr. Code (column 6 of the parts list)

Indicates the code number of the actual manufacturer of the part. (Code to name and address cross reference can be found immediately after this page.)

Mfr. Part No. (column 7 of the parts list)

Indicates actual manufacturer's part number.

Component Number	Tektronix Part No.	Serial No. Effective	Dscont	Name & Description	Mfr. Code	Mfr. Part No.
A1	670-1112-00			CIRCUIT BD ASSY:PROBE	80009	670111200
A2	011-0106-00			TERMN,COAXIAL:P6022	80009	011010600
A1	670-1112-00			CIRCUIT BD ASSY:PROBE	80009	670111200
A1C10	283-0157-00			CAP,FXD,CER DI:7PF,5%,50V	04222	SR155A7R0DAA
A1L10	120-0285-00			XFMR,TOROID:4 TURNS,SINGLE	0JRO3	120-0285-00
A1R10	311-0605-00			RES,VAR,NONWW:TRMR,200 OHM,0.5W	32997	3329H-G48-201
A1T1	120-0603-00			TRANSFORMER,CUR:	80009	120060300
A1T14	120-0286-00			XFMR,TOROID:2 TURNS,BIFILAR,3S76	0JRO3	120-0286-00
A2	011-0106-00			TERMN,COAXIAL:P6022	80009	011010600
A2C21	283-0066-00			CAP,FXD,CER DI:2.5PF,+/-0.5PF,200V	80009	283006600
A2C26	281-0629-00			CAP,FXD,CER DI:33PF,5%,600V	52763	2RDPZZ007 33POJ
A2C28	281-0123-00			CAP,VAR,CER DI:5-25PF,100V	59660	518-000A5-25
A2C29	281-0123-00			CAP,VAR,CER DI:5-25PF,100V	59660	518-000A5-25
A2C37	281-0186-00			CAP,VAR,PLASTIC:1.1-3.5PF,100V	80009	281018600
A2L26	108-0409-01			COIL,RF:FIXED,17.5UH	0JRO3	108-0409-01
A2L28	108-0523-00			XFMR,TOROID:FIXED,160NH	0JRO3	108-0523-00
A2L33	108-0395-00			COIL,RF:FIXED,64UH	0JRO3	108-0395-00
A2R26	321-0014-00			RES,FXD,FILM:13.7 OHM,1%,0.125W,TC=T0	91637	CMF55116G13R70F
A2R28	317-0201-00			RES,FXD,CMPSN:200 OHM,5%,0.125W	TK1727	SFR16 2322-180-
A2R29	321-0751-06			RES,FXD,FILM:50 OHM,0.25%,0.125W,TC=T9	57668	CRB14 CZE 50.0
A2R31	321-0210-00			RES,FXD,FILM:1.50K OHM,1%,0.125W,TC=T0	91637	CMF55116G15000F
A2R33	321-0078-00			RES,FXD,FILM:63.4 OHM,1%,125W,TC=T0	91637	CMF55116G63R40F
A2R34	321-0002-00			RES,FXD,FILM:10.2 OHM,1%,0.125W,TC=T0	91637	CMF55116G10R20F
A2R35	321-0003-00			RES,FXD,FILM:10.5 OHM,1%,0.125W	91637	CMF55116G10R50F
A2R36	317-0270-00			RES,FXD,CMPSN:27 OHM,5%,0.125W	TK1727	SFR16 2322-180-
A2R37	317-0300-00			RES,FXD,CMPSN:30 OHM,5%,0.125W	TK1727	SFR16 2322-180-
A2R39	317-0240-00			RES,FXD,CMPSN:24 OHM,5%,0.125W	TK1727	SFR16 2322-180-
A2SW30	260-0723-00			SWITCH,SLIDE:DPDT,0.5A,125VAC	79727	GF126-0028

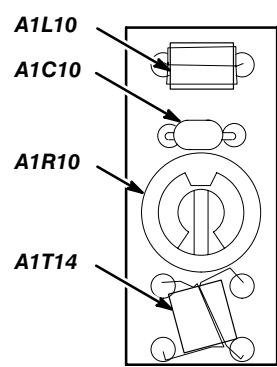

Figure 9: P6022 Probe Component Location

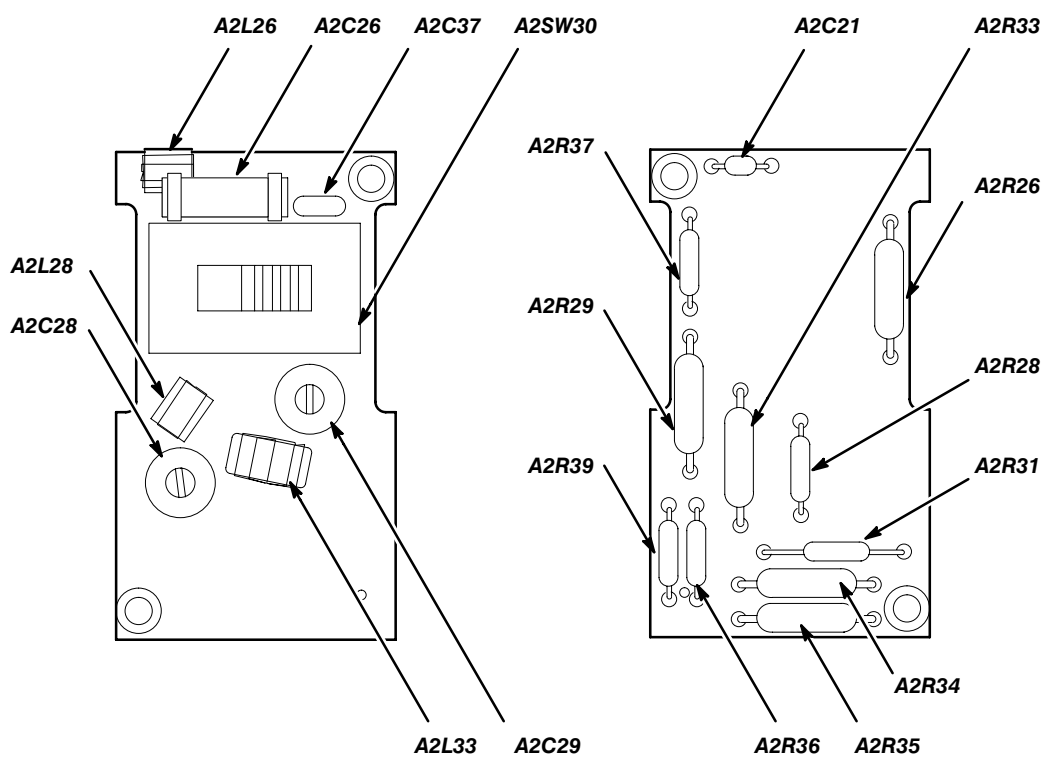

Figure 10: P6022 Termination Component Location

CROSS INDEX – MFR. CODE NUMBER TO MANUFACTURER

Mfr. Code	Manufacturer	Address	City, State, Zip Code
TK1727	PHILIPS NEDERLAND BV AFD ELONCO	POSTBUS 90050	5600 PB EINDHOVEN THE NETHERLANDS
0JR03	ZMAN MAGNETICS INC	7633 S 180th	KENT WA 98032
04222	AVX CERAMICS DIV OF AVX CORP	19TH AVE SOUTH P O BOX 867	MYRTLE BEACH SC 29577
32997	BOURNS INC TRIMPOT DIV	1200 COLUMBIA AVE	RIVERSIDE CA 92507–2114
52763	STETCO INC	3344 SCHIERHORN	FRANKLIN PARK IL 60131
57668	ROHM CORP	8 WHATNEY PO BOX 19515	IRVINE CA 92713
59660	TUSONIX INC	7741 N BUSINESS PARK DR PO BOX 37144	TUCSON AZ 85740–7144
79727	C–W INDUSTRIES	130 JAMES WAY	SOUTHAMPTON PA 18966–3818
80009	TEKTRONIX INC	14150 SW KARL BRAUN DR PO BOX 500	BEAVERTON OR 97077–0001
91637	DALE ELECTRONICS INC	2064 12TH AVE PO BOX 609	COLUMBUS NE 68601–3632

Replaceable Mechanical Parts

This section contains a list of the mechanical parts that are replaceable for the P6022. Use this list to identify and order replacement parts.

Parts Ordering Information

Replacement parts are available from or through your local Tektronix, Inc. service center or representative.

Changes to Tektronix instruments are sometimes made to accommodate improved components as they become available and to give you the benefit of the latest circuit improvements. Therefore, when ordering parts, it is important to include the following information in your order:

- Part number
- Instrument type or model number
- Instrument serial number
- Instrument modification number, if applicable

If a part you order has been replaced with a different or improved part, your local Tektronix service center or representative will contact you concerning any change in the part number.

Change information, if any, is located at the rear of this manual.

Using the Replaceable Parts List

The tabular information in the Replaceable Parts List is arranged for quick retrieval. Understanding the structure and features of the list will help you find the all the information you need for ordering replacement parts.

Item Names

In the Replaceable Parts List, an Item Name is separated from the description by a colon (:). Because of space limitations, an Item Name may sometimes appear as incomplete. For further Item Name identification, U.S. Federal Cataloging Handbook H6-1 can be used where possible.

Abbreviations

Abbreviations conform to American National Standards Institute (ANSI) standard Y1.1

Fig. & Index No.	Tektronix Part No.	Serial No. Effective	Dscont	Qty	12345 Name & Description	Mfr. Code	Mfr. Part No.
11 -	-----			1	P6022,PROBE,CURRENT:120 MHZ,100A,5FT W/TERM		
-1	204-0360-01			1	.BODY,PROBE:UPPER	80009	204036001
-2	214-0581-00			1	.BALL,DETENT:0.062 DIA STEEL	80009	214058100
-3	351-0174-00			1	.SLIDE,TEST PROD:ACETAL	80009	351017400
-4	214-0735-00			1	.SPRING,HLCPS:0.12 OD X 1.5 L,OPEN ENDS,MUW	8X345	ORDER BY DESC
-5	214-1110-00			1	.RETAINER,SPRING:CURRENT PROBE	80009	214111000
-6	-----			1	.TRANSFORMER,CUR:(SEE A1T1 REPL)		
-7	-----			1	.CIRCUIT BD ASSY:PROBE(SEE A1 REPL)		
-8	204-0362-02			1	.BODY ASSY,PROBE:LOWER	80009	204036202
-9	175-1027-00			1	.CABLE ASSY,RF:62.5 OHM COAX,60.0 L (STANDARD ONLY)	80009	175102700
	175-1027-01			1	.CABLE ASSY,RF:62.5 OHM COAX,108.0 L (OPTION 03 ONLY)	80009	175102701
-10	200-0852-06			1	.COV,COAX TERMN:W/SHLD & KNOB	80009	200085206
-11	426-0423-03			1	.FRAME,COAX TERM:	80009	426042303
-12	131-0106-02			1	.CONN,RF JACK:BNC,;50 OHM,FEMALE, ,SLDR CUP/FRONT PNL,0.520 MLG X 0.403 TAIL,0.04 L .SLDR CUP,0.380,D/1 FLAT	24931	28JR178-1
-13	131-0602-00			1	.CONN,RF PLUG::BNC,;50 OHM,MALE,STR, FEEDTHRU./FRONT PNL,1.555 L,0.285 L .0.375-32 THD,0.5. L 22 AWG TAB,0.384 DIA MTG	24931	28PR104-1
-14	361-0219-00			2	.SPACER,SLEEVE:0.06 L X 0.093 ID,BRS	80009	361021900
-15	-----			1	.TERMN,COAXIAL:(SEE A2 REPL) ATTACHING PARTS		
-16	211-0001-00			2	.SCREW,MACHINE:2-56 X 0.25,PNH,STL END ATTACHING PARTS	TK0435	ORDER BY DESC
-17	200-0851-03			1	.COV,COAX TERMN:	80009	200085103
					STANDARD ACCESSORIES		
-18	196-3120-01			1	LEAD,ELEC,PROBE GROUND;SDI,23 AWG,6.0 L	80009	196312001
	070-0948-03			1	MANUAL,TECH:INSTRUCTION,P6022	80009	070094803

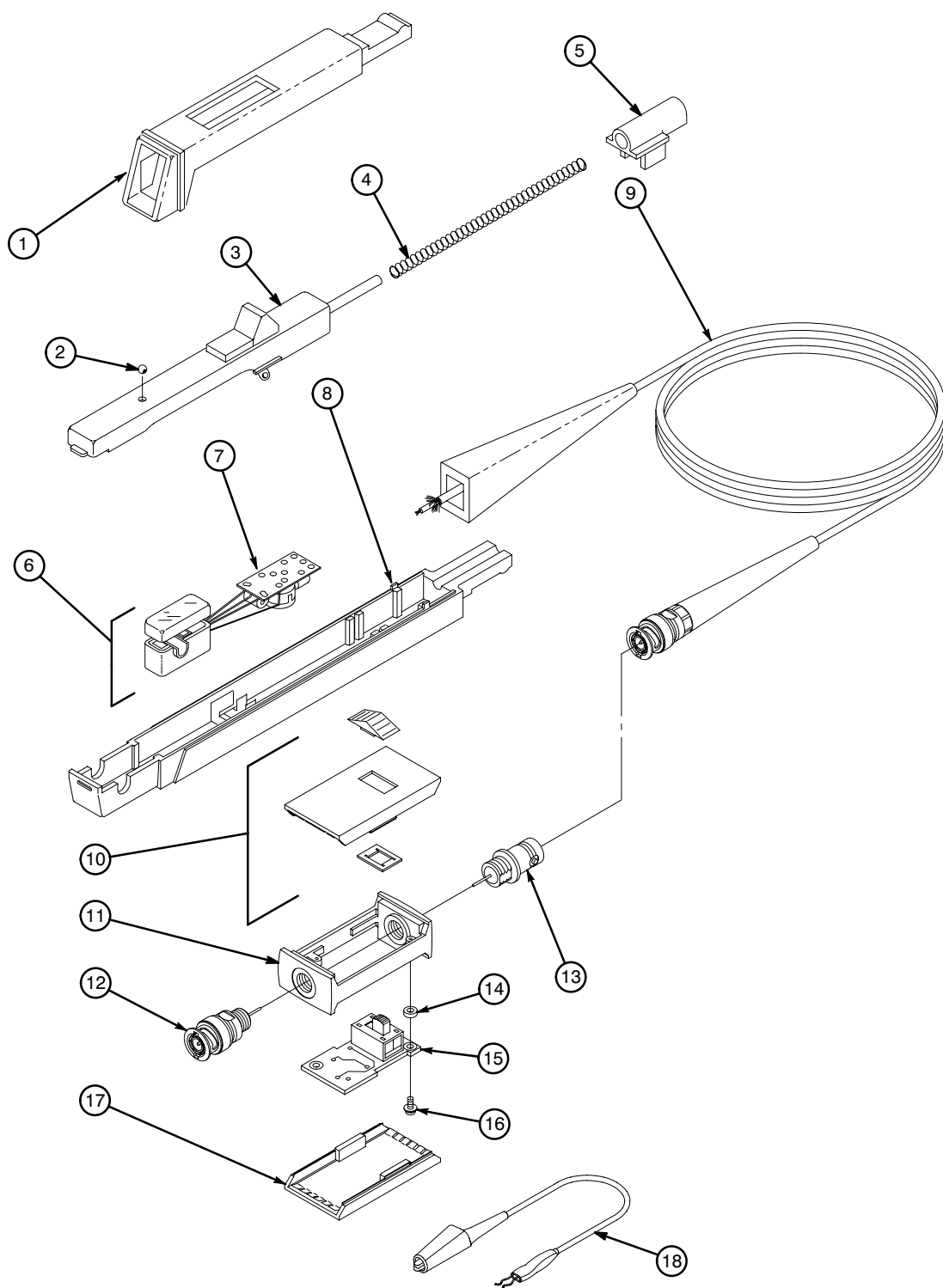

Figure 11: P6022 Exploded View

CROSS INDEX – MFR. CODE NUMBER TO MANUFACTURER

Mfr. Code	Manufacturer	Address	City, State, Zip Code
TK0435	LEWIS SCREW CO	4300 S RACINE AVE	CHICAGO IL 60609–3320
24931	SPECIALTY CONNECTOR CO INC	2100 EARLYWOOD DR PO BOX 547	FRANKLIN IN 46131
8X345	NORTHWEST SPRING & MFG CO	5858 WILLOW LANE	LAKE OSWEGO OR 97034–5343
80009	TEKTRONIX INC	14150 SW KARL BRAUN DR PO BOX 500	BEAVERTON OR 97077–0001

Index

A

aberrations, *17–19*
accessories, termination, *1, 2*
accessories, standard, *3–6*
 6-inch ground lead, *3*
 instruction manual, *3*
accuracy, *7*
adjusting the probe, *18*
adjusting the termination, *18*
attaching the probe, *1–3*

B

bandwidth
 checking, *20, 21*
 specification, *7*

C

C13, *18*
C22, *19*
C25, *19*
cable, 9-foot, *1*
calibrating the probe, *14–15*
Certifications, *9*
checking performance, *14*
circuit description, *12–13*
cleaning the probe, *22*
Compliances, *9*
continuous current, maximum, *8*
current flow, direction, *4*
current vs. frequency derating, *9*

D

DC saturation, maximum, *11*
direction of current flow, *4*
disassembling the probe, *22–24*

E

electrical parts list, *27*
electrical specifications, *7*
 accuracy, *7*
 bandwidth, *7*
 continuous current, maximum, *8*
 DC saturation, maximum, *11*
 input voltage, maximum, *8*
 insertion impedance, *11*
 pulse current, maximum, *8*
 sensitivity, *7*
 signal delay, *11*
 tilt, *11*
environmental specifications, *11*
 altitude, *8*
 temperature, *8*
equipment for calibration, *15*

F

ferrite core, *12*
frequency derating, *9*

G

ground clips, using, *2*
ground lead, 6-inch, *3*

grounding the probe, *3, 5*

H

high frequency response, *3, 21*

I

impedance, *5, 12*
 of oscilloscope, *1, 12*
 probe, *5*
impedance-matching network, *12*
input voltage, maximum, *8*
insertion impedance, *5, 11*
instruction manual, *3*
interference, minimizing, *5, 6, 12*

L

loading effect, minimizing, *5*
low frequency response, *20*
lubricating the probe, *22*

M

magnetic shielding, *6*
maximum continuous current, *8*
maximum DC saturation, *11*
maximum input voltage, *8*
maximum pulse current, *8*

mechanical parts list, 33

O

Option 03, 1
options, cable, 9-foot, 1
oscilloscope, 1
 impedance, 1
 input connectors, 1
 use with, 1–3

P

parts list
 electrical, 27
 mechanical, 33
physical specifications, 11
 cable length, 11
 weight, 11
probe
 adjustments, 17–19
 calibration, 14, 15
 circuit description, 12
 compatibility with oscilloscope, 1, 12
 description, 1
 disassembly, 22–24
 impedance of, 5
 parts, 2
 repair, 24
 shielding, 6, 12
pulse current, maximum, 8

R

R10, 18
R12, 18
R36, 19
repairing
 probe, 24
 termination, 24–26
replacing
 termination circuit board, 25
 termination connectors, 24
 transformer, 24

S

safety
 operator information, *iii*
 service information, *v*, 14
schematic diagram, 13
sensitivity, 19
 checking, 19
 specification, 7
sensitivity control, 4, 7, 12
sensitivity setting, 4, 7, 12
service, safety warnings, *v*, 14
shielding, 6, 12
signal delay, 11
sliding switch, 4, 7, 12
soldering, procedures for, 24
specifications, 7
 electrical, 7
 environmental, 11
 physical, 11

T

termination, 1, 2
 adjustments, 17–19
 circuit description, 12–13
 repair, 24–26
 replacing circuit board, 25
 replacing connectors, 24
test equipment, 15
 function generator settings, 16
 oscilloscope settings, 16
 pulse generator settings, 16
tilt, 11
transformer, 12
 maintenance, 22
 matching, 24
 primary, 4
 replacing, 24
 secondary, 4
turns ratio, 12

V

vertical scale settings, with oscilloscope, 4
vertical sensitivity, 4, 12
 increasing, 5
voltage, maximum, 8

W

winding, 5, 12

X-ON Electronics

Largest Supplier of Electrical and Electronic Components

Click to view similar products for [Test Probes](#) category:

Click to view products by [Tektronix](#) manufacturer:

Other Similar products are found below :

[6214](#) [6265](#) [6474](#) [815003](#) [923832-BK-B](#) [P-KIT-1](#) [R941850000](#) [923837-YL-B](#) [925250-R](#) [72923-2](#) [923848-C](#) [973368101](#) [972318101](#)
[972318100](#) [MXHQ87WJ3000](#) [66.9115-23](#) [850182](#) [TAS90](#) [VL1735/45](#) [973368100](#) [972327100](#) [972327101](#) [975017700](#) [975018700](#)
[973995100](#) [973995101](#) [100039-080-958](#) [CT3986B-120](#) [CT3987B-120](#) [CT3983B-120](#) [CT3979B-150](#) [CT3981B-120](#) [CT3985B-120](#) [402-IEC-](#)
[RT](#) [402-IEC-SW](#) [404-IEC-RT](#) [AX-CP-01-SET](#) [AX-CP-05-B](#) [AX-CP-05-R](#) [464-IEC-NEEDLE13/0,6-RT](#) [464-IEC-NEEDLE13/0,6-SW](#) [464-](#)
[IEC-RT](#) [464-IEC-SW](#) [00043](#) [404-IEC-SW](#) [00125](#) [1445](#) [MPS1RT](#) [0602](#) [4592](#) [0602](#) [0645](#)