

Instructions



RMD3000 DPO3000 Series Rackmount Kit 071-2424-00

Warning

The servicing instructions are for use by qualified personnel only. To avoid personal injury, do not perform any servicing unless you are qualified to do so. Refer to all safety summaries prior to performing service.

www.tektronix.com



071242400

Copyright © Tektronix. All rights reserved. Licensed software products are owned by Tektronix or its subsidiaries or suppliers, and are protected by national copyright laws and international treaty provisions.

Tektronix products are covered by U.S. and foreign patents, issued and pending. Information in this publication supercedes that in all previously published material. Specifications and price change privileges reserved.

TEKTRONIX and TEK are registered trademarks of Tektronix, Inc.

Contacting Tektronix

Tektronix, Inc.
14200 SW Karl Braun Drive
P.O. Box 500
Beaverton, OR 97077
USA

For product information, sales, service, and technical support:

- In North America, call 1-800-833-9200.
- Worldwide, visit www.tektronix.com to find contacts in your area.

Service Safety Summary

Only qualified personnel should perform service procedures. Read this *Service Safety Summary* and the *General Safety Summary* in the product service manual or the instruction manual.

Do Not Service Alone. Do not perform internal service or adjustments of this product unless another person capable of rendering first aid and resuscitation is present.

To prevent the instrument and rack from falling onto the operator, two or more installers should install the instrument into the rack cabinet. After completing the installation procedure, the installers should verify that the instrument and rack cabinet will not tip forward while the instrument is in the extended position.

Disconnect Power. To avoid electric shock, switch off the instrument power, then disconnect the power cord from the mains power.

Use Care When Servicing With Power On. Dangerous voltages or currents may exist in this product. Disconnect power and disconnect test leads before removing protective panels, soldering, or replacing components.

To avoid electric shock, do not touch exposed connections.

Kit Description

This introduction describes the rackmount kit for your standard bench-top instrument.

The rackmount kit is a collection of parts that, once installed, configure the instrument for mounting into a standard 19-inch equipment rack.

Products

DPO3000 Series All Serial Numbers

Kit Parts List

The following parts list describes the parts included in the rackmount kit. The hardware package of screws, washers, and handles are used by other rackmount kits; not all of the parts will be used in installing this rackmount kit.

NOTE. Rack slides are not included as part of this rackmount kit; they must be ordered separately.

Table 1: Kit Parts List

Circuit/figure number	Quantity	Part number	Description
-----	1 each	RMD3000	RACKMOUNT KIT DPO3000 SERIES, CONSISTING OF THE FOLLOWING:
-----	1 each	071-2424-00	MANUAL; INSTRUCTIONS; RACKMOUNT, ENGLISH, DPO3000 SERIES
1-1	1 each	407-5325--xx	BRACKET, BOTTOM RMD3000 RACKMOUNT KIT
1-2	1 each	407-5326-xx	BRACKET, REAR FEET RMD3000 RACKMOUNT KIT
1-3	1 each	407-5327-xx	BRACKET, TOP RMD3000 RACKMOUNT KIT
1-4	2 each	407-5330-xx	BRACKET, HANDLE SUPPORT RMD3000 RACKMOUNT KIT
1-5	1 each	407-5329-xx	BRACKET, LEFT SIDE RMD3000 RACKMOUNT KIT
1-6	1 each	407-5328-xx	BRACKET, RIGHT SIDE RMD3000 RACKMOUNT KIT
1-7	1 each	426-2633-xx	FACEPLATE, RIGHT RMD3000 RACKMOUNT KIT

Table 1: Kit Parts List (Cont.)

Circuit/figure number	Quantity	Part number	Description
1-8	1 each	426-2634-xx	FACEPLATE, LEFT RMD3000 RACKMOUNT KIT
1-9	2 each	367-0450-xx	HANDLE, BOW; CARRYING, 3.75 CTR, 8-32 THD 1.75 H, TG2000, SAFETY CONTROLLED
Not shown	4 each	210-0833-xx	WASHER, RECESSED; 0.42 ID X 0.112 THK, STL NI PLATED, 0.588 OD
Not shown	4 each	210-1061-xx	WASHER, FLAT; 0.203 ID X 0.625 OD X 0.062, 410 SS, PASSIVATE
Not shown	4 each	210-1546-xx	SCREW, MACHINE, PAN, 8-32 X 1/2 PHIL, SST
Not shown	4 each	210-1547-xx	LOCKWASHER, #8, SPLIT, .040 THICK
Not shown	4 each	210-1548-xx	WASHER, FLAT, 12 mm OD X 6.4 mm ID X 1.6 mm THK, STAINLESS STEEL
Not shown	14 each	211-0507-xx	SCREW, MACHINE; 6-32 X 0.312, PNH, 410 SS PASSIVATED, POZ
Not shown	4 each	211-0538-xx	SCREW, MACHINE; 6-32 X 0.312, FLH, 100 DEG, 410 SS PASSIVATED, POZ
Not shown	4 each	211-1218-xx	M6 X 16MM PHIL OVAL HEAD, 410 SS, PASSIVATE
Not shown	4 each	211-1219-xx	SCREW, M5 X 16MM PHIL OVAL, 410 SS, PASSIVATE
Not shown	4 each	212-0043-xx	SCREW, MACHINE; 8-32 X 0.5, FLH, 100 DEG, 410 SS, POZ
Not shown	4 each	212-0591-xx	SCREW, MACHINE; 10-32 X 0.75, OVH, POZ, STL, NI
Not shown	4 each	213-0199-xx	SCREW, MACHINE; 12-24 X 0.75, OVH, STL NP, POZ

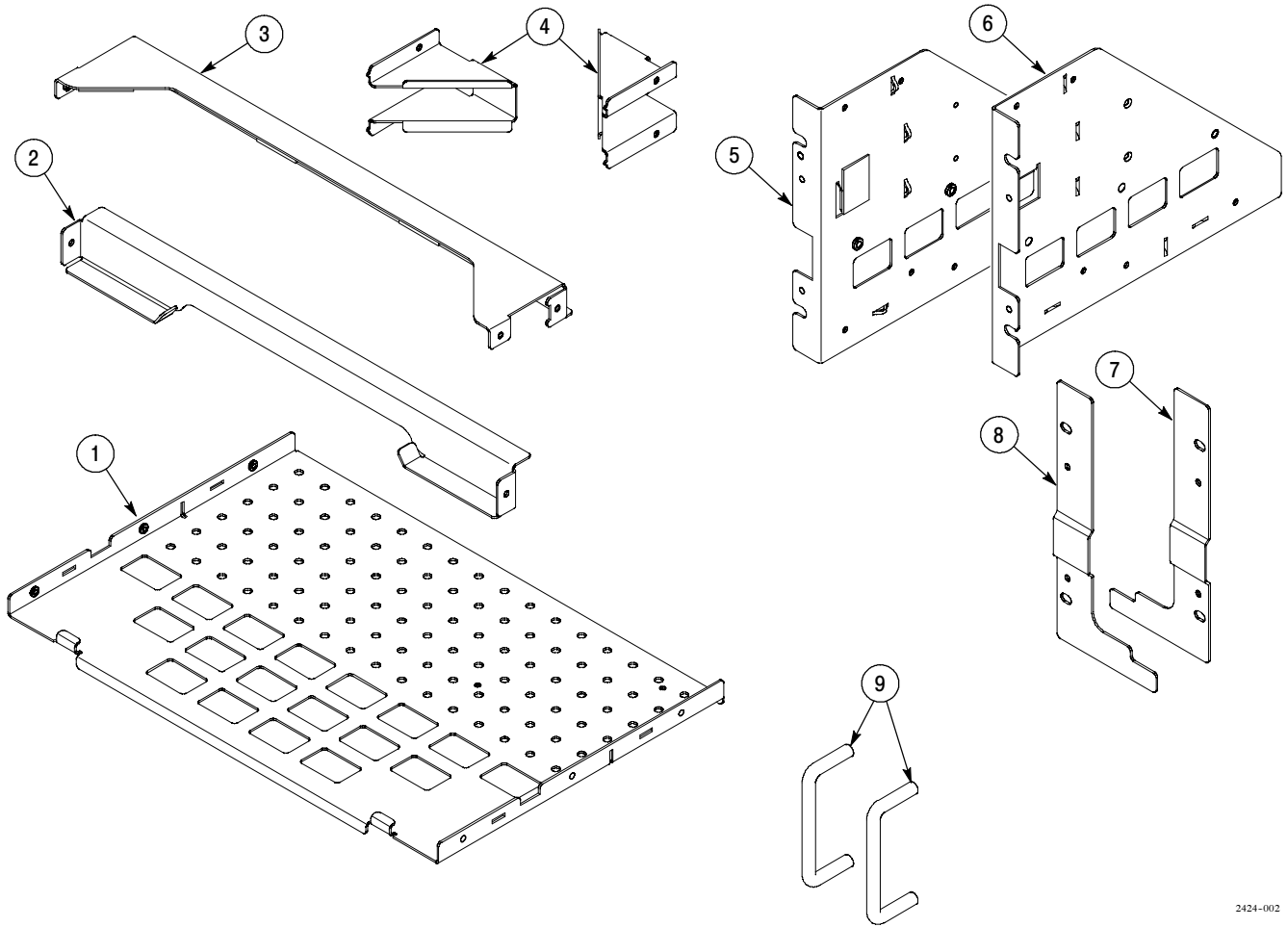

2424-002

Figure 1: Rackmount kit parts

Table 2: Optional Accessories (must be ordered separately)

Circuit/figure number	Quantity	Part number	Description
2-1	1 pair	351-1095-00	SLIDE ASSY; PAIR, W/STD HARDWARE KIT AND REAR BRACKET

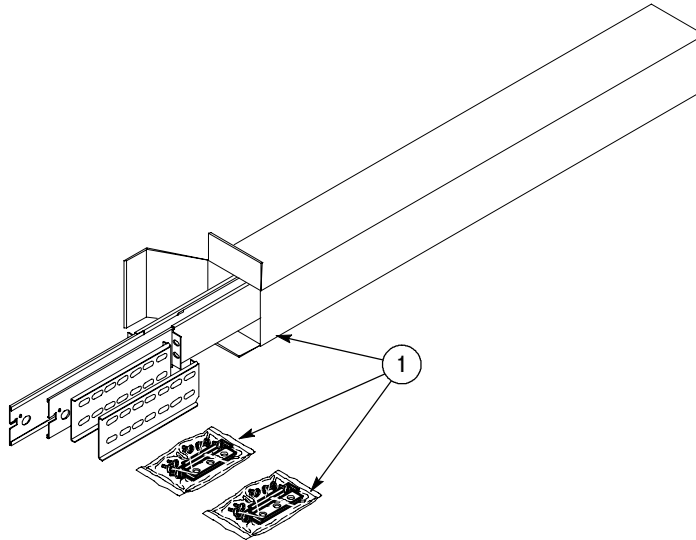

Figure 2: Optional rack slide kit for rackmount

Clearance Requirements

The rack in which the rack adapted instrument is mounted must provide the following clearance requirements:

- A minimum of 222.25 mm (8.75 in) of vertical space
- A minimum width of 450.09 mm (17.72 in) between the left- and right-front rails in the rack
- A minimum depth of 342.90 mm (13.50 in)



CAUTION. *Adhering to these clearance requirements provides the rack-mounted instrument with sufficient clearance for air circulation and accommodation of the power cord and mounting hardware. Failure to provide these clearances can result in overheating and can cause instrument faults or failure.*

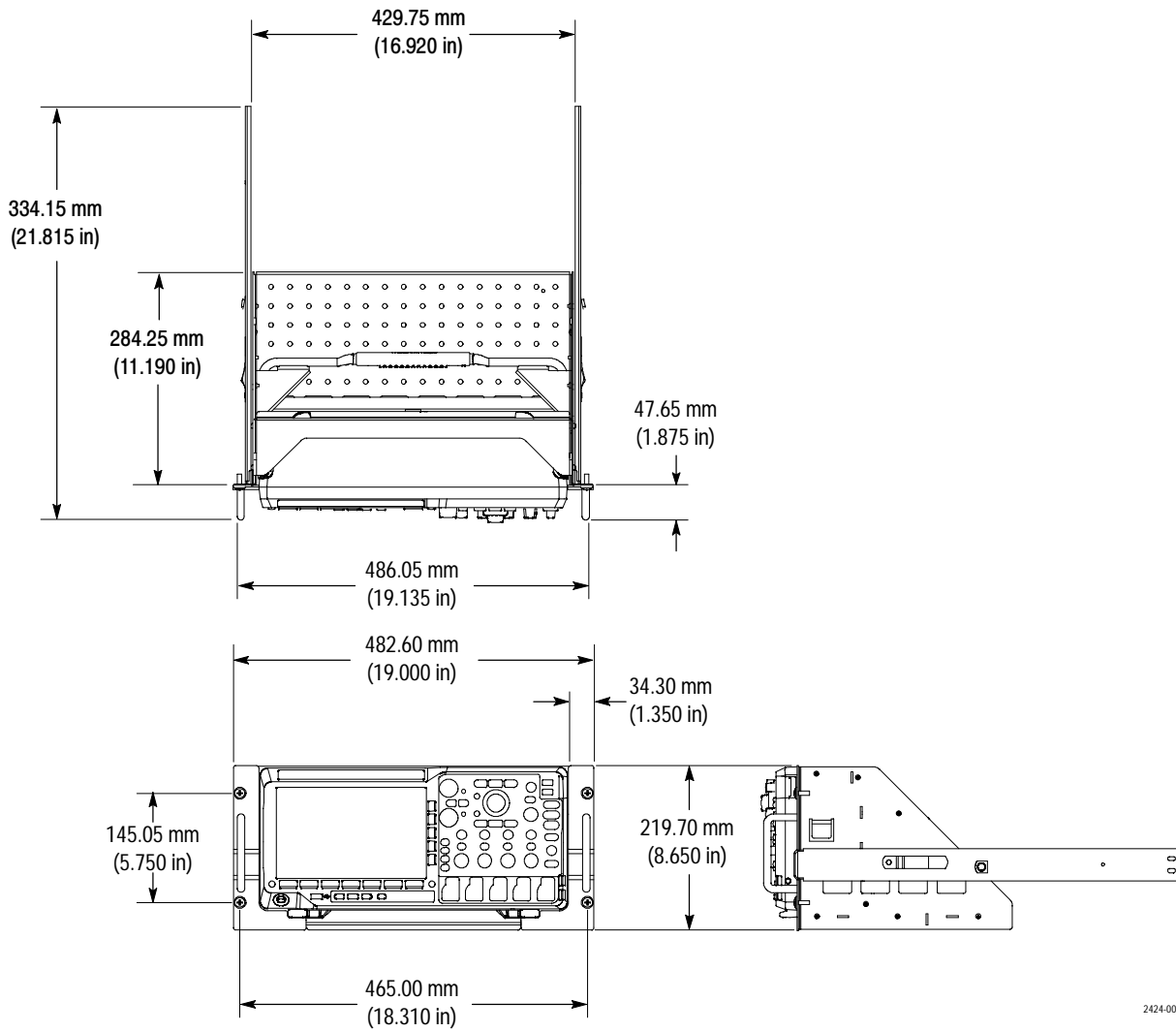

2424-001

Figure 3: Instrument with rack adapter installed

Installation Instructions

This section contains the procedures needed to rackmount a DPO3000 series instrument.

Minimum Tool and Equipment List

The following tools are required to attach the rack-adapter kit hardware, install cabling hardware, and mount the rack-adapted instrument into a standard equipment cabinet. All tools are standard tools that are readily available.

Table 3: Tools required for rackmount installation

Item no.	Name	Description
1	Screwdriver handle (magnetic)	Accepts 1/4-inch hexagonal head driver tips
2	No. 2 Pozidriv or Phillips tip	Pozidriv or-Phillips driver tip for number 2 size screw heads
3	Straight tip	Straight screwdriver tip for slotted screw heads
4	1/4-inch wrench	Wrench or nut driver can be used to install slides
5	Torque driver	6.5 in long shaft; accepts 1/4-inch hexagonal head driver tips

These instructions are for qualified service personnel who are familiar with servicing the product. If you need further details for disassembling or reassembling the product, refer to the appropriate product manual. Contact your nearest Tektronix Service Center or Tektronix Factory Service for installation assistance.



WARNING. *To prevent the rackmounted instrument from tipping forward onto the operator, install the instrument so that the operator will be able to access all of its rear-panel connectors without pushing down on the instrument.*

Verify that the rack does not become unstable with the instrument fully extended. Do not leave the instrument extended when finished accessing the rear panel.

Install

Equipment Required: Torque driver with #2 Pozidriv tip (Items, 5, and 6).

This section describes mounting the rackmount adapter parts to the instrument.

1. Install the left and right side brackets onto the bottom bracket using three of the 6-32 x 0.312 inch pan head Pozidriv screws on each side. See Figure 4. Tighten these screws to 8 in-lb.

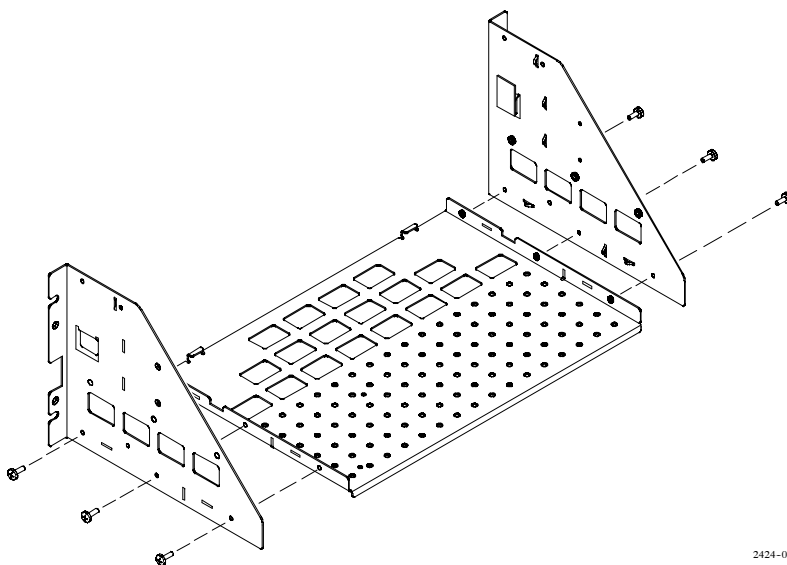
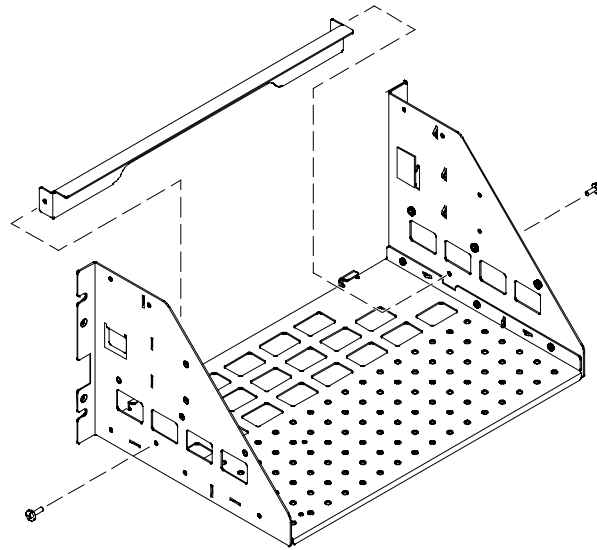

Figure 4: Assembling the rack adapter sides and bottom brackets

2. Install the rear feet bracket onto the bottom bracket using two of the 6-32 x 0.312 inch pan head Pozidriv screws, tightened to 8 in-lb. See Figure 5.



2424-004

Figure 5: Installing the rear feet bracket

3. Place the right faceplate into position, and then install the right handle using two of the 8-32 x 0.5 inch flat head Pozidriv screws tightened to 16 in-lb. See Figure 6. Installing the handle secures the faceplate in place.
4. Repeat Step 3, using the left faceplate and handle.

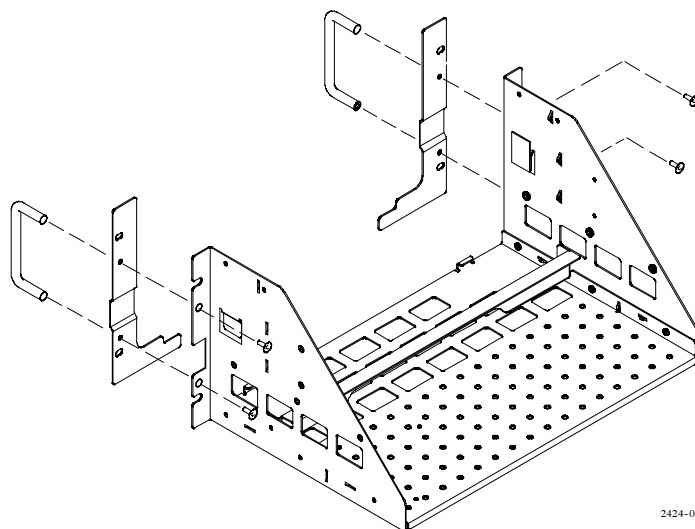

2424-005

Figure 6: Installing the right and left faceplates

5. Place the oscilloscope into the rackmount frame, as shown in Figure 7. Position the oscilloscope's rear feet against the rear feet bracket. The front of the oscilloscope will extend slightly beyond the two faceplates.

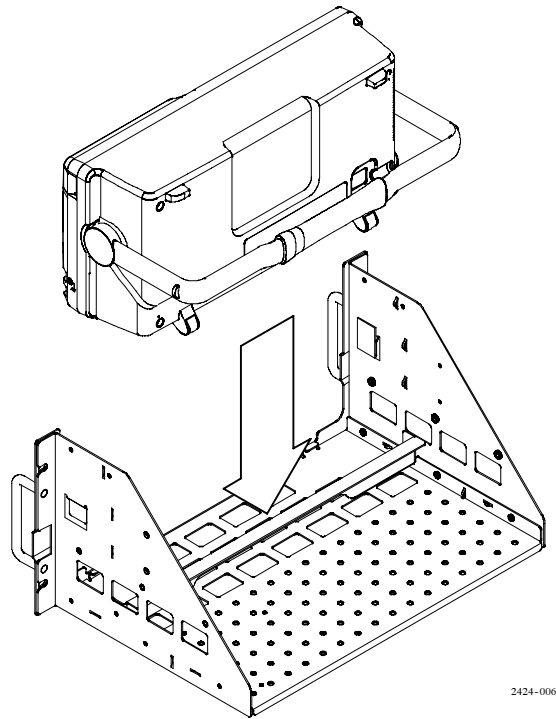
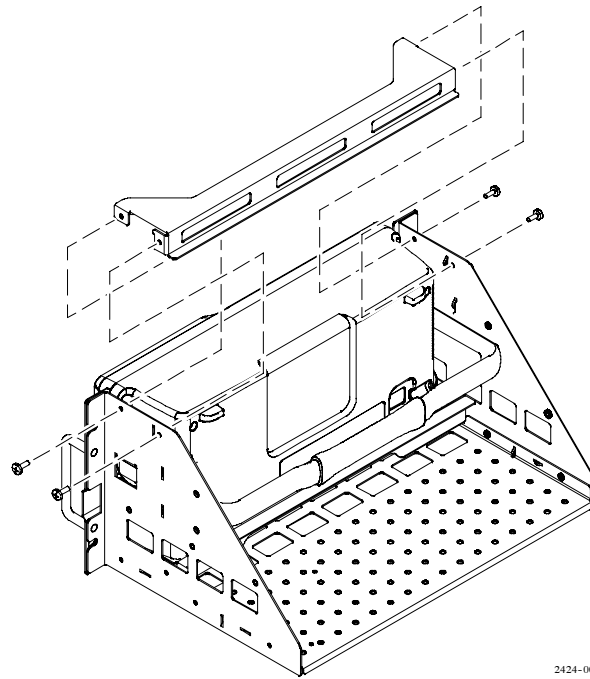

Figure 7: Placing the oscilloscope into the rack adapter

NOTE. *There is sufficient clearance between the bottom of the oscilloscope and the rack adapter, allowing cables to be routed from the front of the oscilloscope to the back.*

6. Position the oscilloscope handle so that it extends straight to the back, as shown in Figure 7. There is no detent in this position.
7. Install the top bracket by sliding it into place from the back, so that the two top feet on the oscilloscope fit through the slots in the bracket. Attach the bracket with two of the 6-32 x 0.312 inch pan head Pozidriv screws, provided in the kit, on each side. See Figure 8.



2424-008

Figure 8: Installing the top bracket

8. Place the handle brackets around the handle, slipping the front of the brackets into the reliefs stamped into the rackmount side brackets. Attach the handle brackets using the four 6-32 x 0.312 inch flat head Pozidriv screws provided in the kit. Tighten these screws to 8 in-lb. See Figure 9.

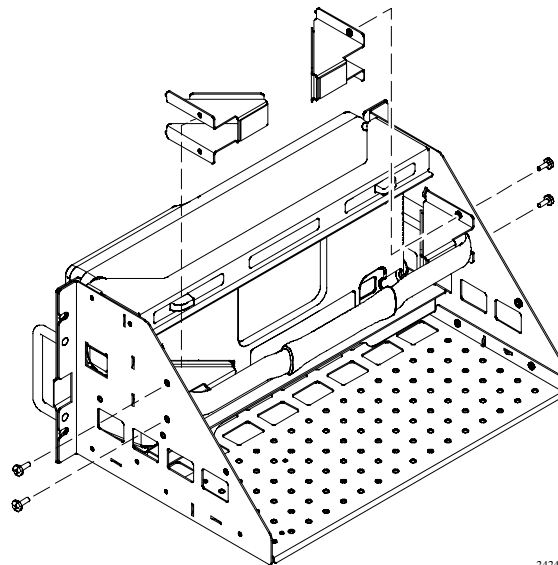

2424-007

Figure 9: Installing the handle brackets

NOTE. The bottom bracket has holes to facilitate mounting optional accessories. For example, Figure 10 shows a TEK-USB-488 GPIB to USB Adapter and an optional Probe Power Adapter mounted to the back support. Optional accessories may be mounted with screws, or you can use nylon straps to secure them.

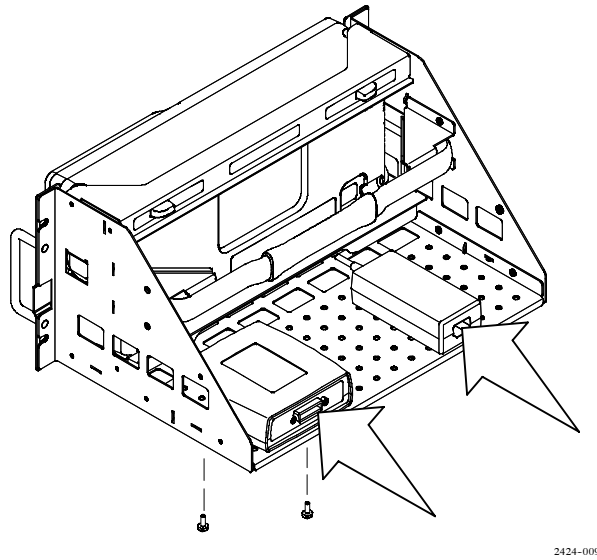

Figure 10: Installing accessories

Rackmount the Rack-Adapted Instrument without rack slides

If you did not order the optional rackmount slides, you may install the Rack-adapted instrument into an equipment rack by following this procedure:



WARNING. To prevent the instrument from tipping or falling onto the installers, this procedure should be performed by two or more people.

Install Instrument into the Rack

Equipment Required: One screwdriver handle (Item 1) and one number two Pozidriv tip (Item 2).

1. Select the appropriate screws for your equipment rack from the kit; 10-32, 12-24, M5, or M6. Assemble them with the recessed and flat washers as shown:

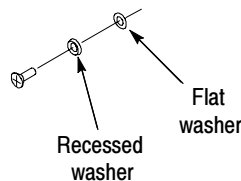

Screw type	Use this flat washer
10-32	0.625 in. OD
12-32	12 mm OD
M5	0.625 in. OD
M6	12 mm OD

2. Standard equipment racks utilize one of two mounting hole spacing methods. Both methods use mounting holes spaced 0.5 inch apart, separated by a 1.25 inch gap. One method (A) places an additional mounting hole in the middle of the 1.25 inch gap (at 0.625, or $\frac{5}{8}$, inch); the other method (B) does not. See Figure 11.

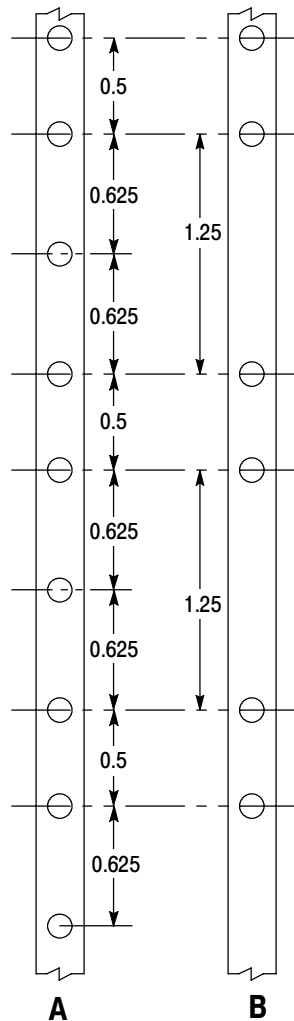

Figure 11: Rack mounting hole spacing

3. Select two 0.5 inch-spaced holes in the front rail. Verify that there are clearances of 1.5 inch above the upper mounting hole and 6.75 inch below the lower mounting hole.
4. Slide the oscilloscope into the equipment rack so that the pin extending back from the left side, just below the upper mounting hole, goes into the lower of the 0.5 inch-spaced holes in the front rail. This pin is a locating guide, and also an aid to holding the oscilloscope in place while securing the oscilloscope to the instrument rack.
5. Use the screws and washers from step 1 to secure the oscilloscope to the instrument rack.

Rackmount the Rack-Adapted Instrument using rack slides

If you ordered the optional rackmount slides, this procedure assembles and installs the slide-out tracks in the equipment rack, and then installs the rack-adapted instrument in the rack.

The slide-out tracks permit the rack-adapted instrument to be extended out of the rack for rear-panel and connector maintenance without removing the instrument from the rack.



WARNING. *To prevent the rackmounted instrument from tipping forward onto the operator, install the instrument so that the operator will be able to access all of its rear devices without pushing down on the instrument.*

Verify that the rack does not become unstable with the instrument fully extended. Do not leave the instrument extended when finished accessing the rear panel.

Install Track Assembly and Instrument into the Rack

Equipment Required: One screwdriver handle (Item 1), one number two Pozidriv tip (Item 2), one straight slot tip (item 2) and one torque driver (Item 5).

NOTE. *The rack hardware kit contains hardware for mounting the instrument in several configurations. Not all of the hardware in the kit will be needed.*

Procedure:

1. Attach the front (chassis) left and right tracks to the rack adapter:
 - a. Remove the front (chassis) section of each of the two tracks. See Figure 12.
 - b. Install the front left- and right-side track sections on the instrument using six of the 10-32 x $\frac{3}{8}$ inch slotted screws tightened to 28 in-lb. See Figure 13.

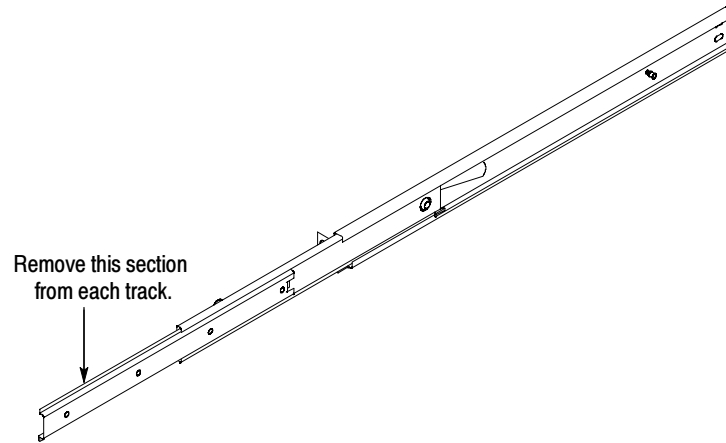

Figure 12: Remove instrument tracks

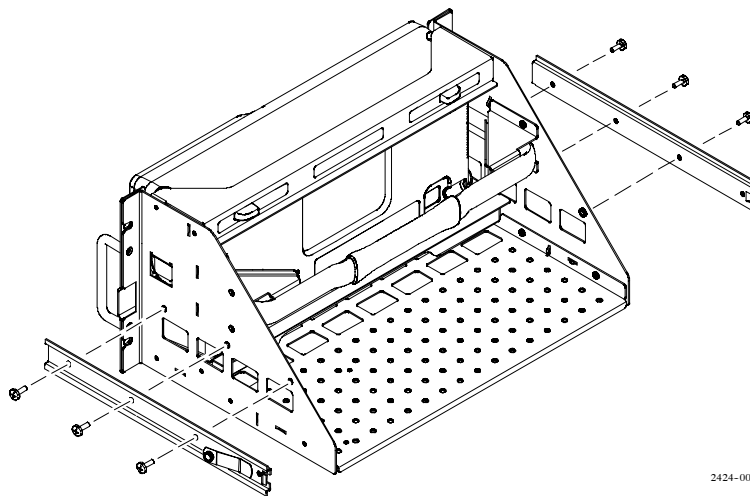

Figure 13: Install slide tracks onto rack adapter



WARNING. To ensure that the rackmount track locks, make sure the track button latches are oriented correctly: the right-side latch is located toward the bottom of the rackmount panel and the left-side latch is located toward the top of the rackmount panel. Refer to Figure 14.

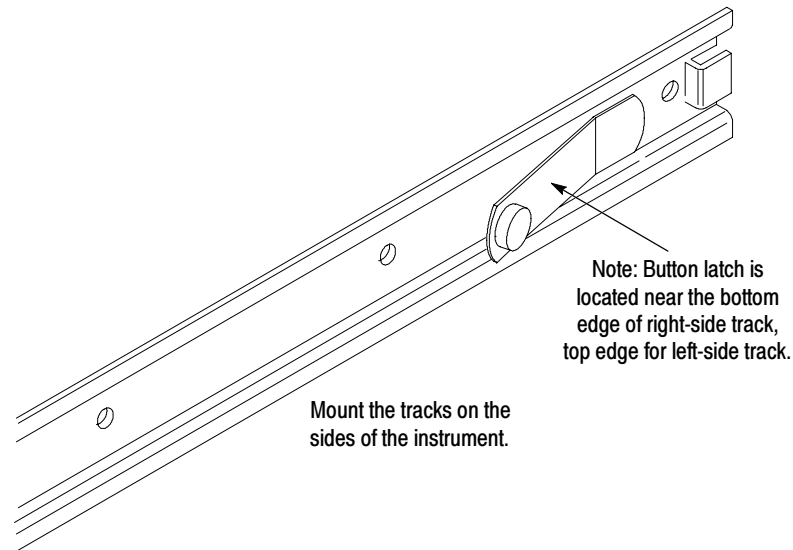

Figure 14: Track orientation

2. Assemble the slide-out track:
 - a. Measure the distance between the front and rear rail of the equipment rack.
 - b. Align the rear bracket to the right slide-out track as shown in Figure 15. Note that the rear bracket has multiple pairs of mount-through holes. When aligning the bracket and track, be sure to select a pair of holes that mount the rear bracket so that the flange-to-flange distance matches the distance between the front rail and rear rail measured in step a.
 - c. Using a screwdriver with a number two Pozidriv tip, secure the rear bracket to the right slide-out track using two screws (10-32) and a bar nut as illustrated. Leave the screws loose so that the overall length of the slide-out track assembly can be adjusted when installing it in the rack.
 - d. Repeat steps b and c to assemble the left slide-out track assembly.
3. Mount the slide-out track assemblies, using the slide drawer hardware listed in the kit parts list, Figure 1-10:
 - a. *Select the mounting position in rack:* Select two 0.5 inch-spaced holes in the front rail. Verify that clearances of 4.875 inch above and 3.25 inch below exist, relative to those mounting holes. See Figure 16 on page 21.

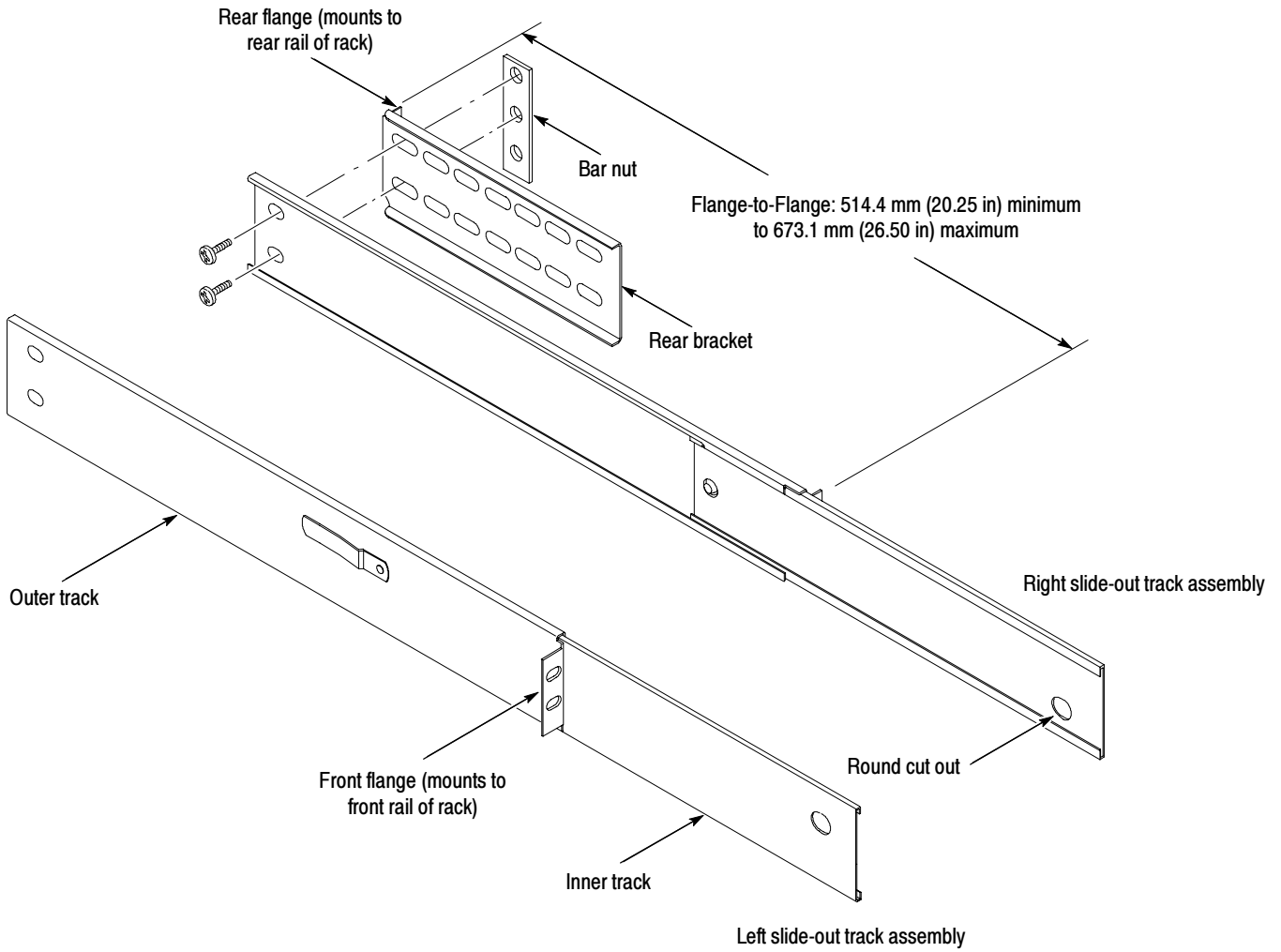

Figure 15: Assembly of slide-out track assemblies

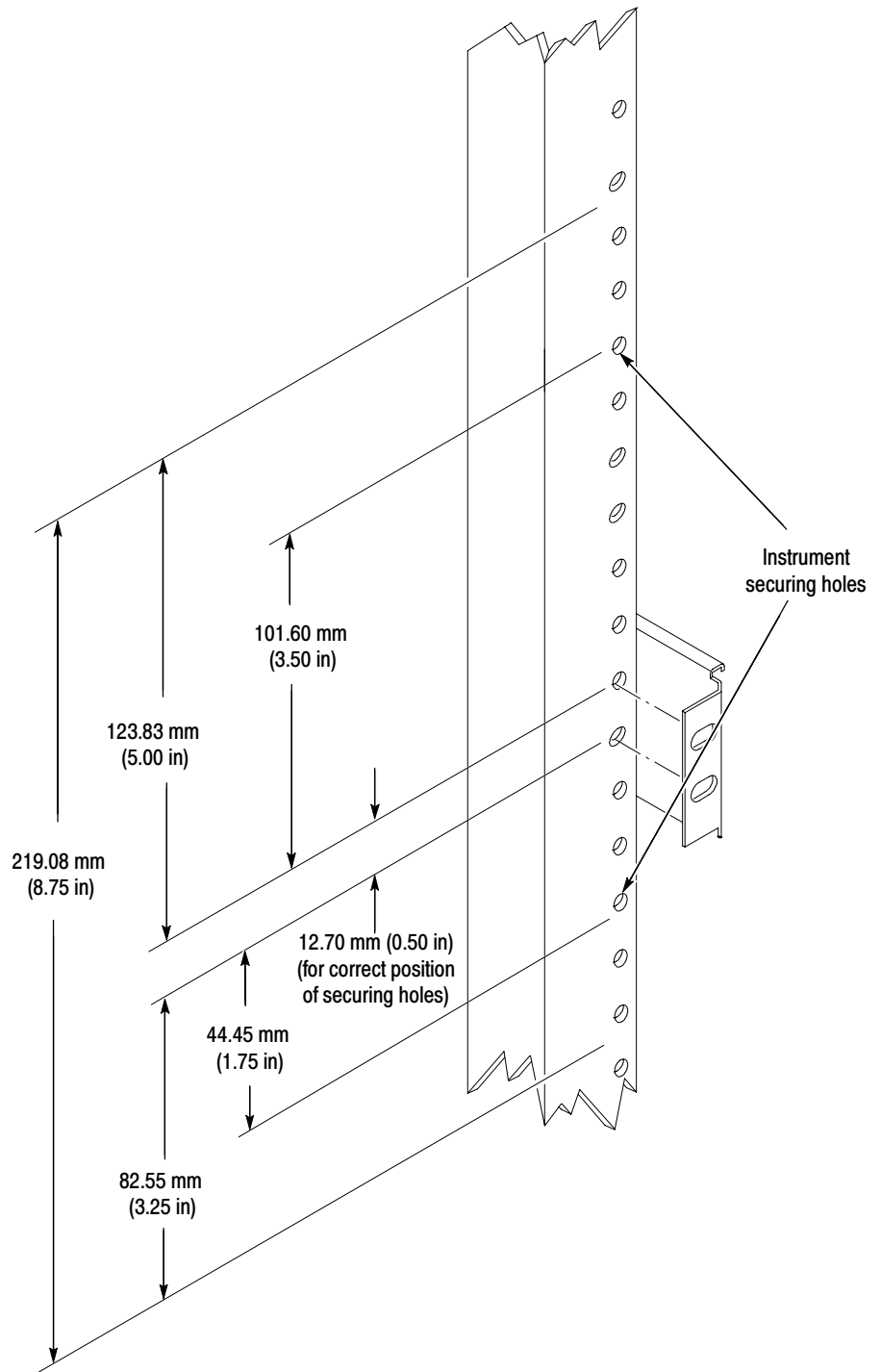

Figure 16: Vertical clearances for rack installation (left-front rail shown)

b. Select mounting method according to rack type:

- To mount the slide-out tracks with their front and rear flanges outside of the front and rear rails, use the mounting method A shown in Figure 17 when doing substep c. Add a bar nut to the installation only if the rails have untapped holes.
- To mount with front and rear flanges inside of rails, use the mounting method B outlined in Figure 17. This mounting method assumes untapped holes.

c. Install in rack: Using the method and hardware determined from substep b, secure the right slide-out track assembly to its front and rear rails. The screws should be fully, but lightly, seated so mounting can be adjusted later.

d. Fix the length of the slide-out track assembly: Tighten the screws, applying 28 inch-lb of torque, left loose in step 1 substep c, to fix the front to rear flange spacing of the slide-out track assembly.

e. Mount the left slide-out track assembly: Repeat substeps c and d to mount the left slide-out track assembly.

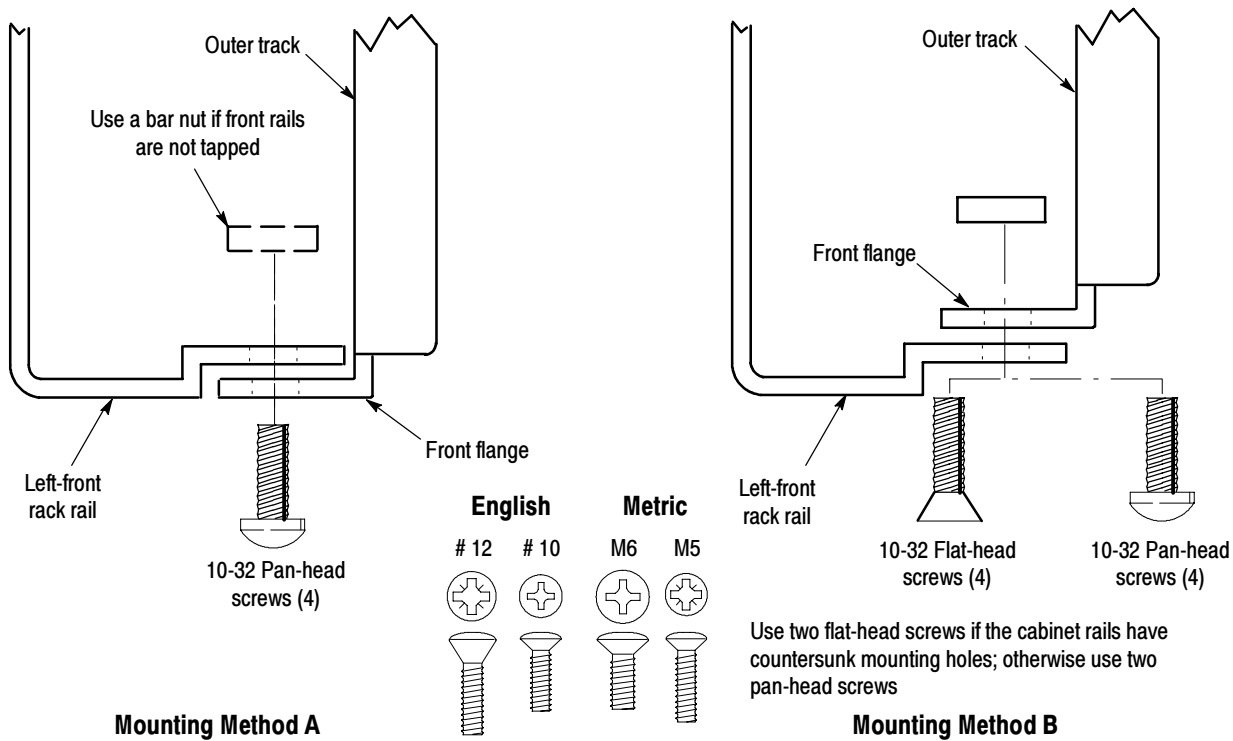

Figure 17: Installation of slide-out track assemblies in rack (top view)

4. Mount the instrument in the rack:



WARNING. *To prevent the instrument from tipping or falling onto the installers, two or more people should install this instrument into the rack cabinet.*

After completing the installation procedure, the installers should verify that the instrument and rack cabinet will not tip forward while the instrument is in the extended position.

a. Install the instrument:

- Working from the front of the rack, slide the inner track of each slide-out track assembly until it extends out the front of the rack. Continue to slide them out until they lock.
- Insert the left and right tracks that extend from the rear of the instrument into the ends of the tracks just extended. Make sure the tracks mounted on the instrument slip inside the inner tracks extended earlier.
- Slide the instrument backwards until it stops.
- Push to release the button latches, located on the outside of each track, and continue to slide the instrument all the way into the cabinet.

b. Level the rackmounted instrument:

- Tighten the four screws that were left loose at the rear of the rack when you did step 3, substep c, and then pull the instrument part way out of the rack.
- Be sure that the four screws that were left loose at the front of the rack are loose enough to allow the slide-out track assemblies to seek their normal positions.
- Retighten the four screws and push the instrument all the way into the rack. If the tracks do not slide smoothly, readjust the level using the method just detailed.
- When leveling is completed, tighten the 10-32 screws using 28 inch-lb of torque.

Finishing the Installation

It is recommended that you secure the instrument to the rack.



WARNING. To prevent the rackmounted instrument from sliding forward and causing personal injury or instrument damage, always secure the instrument to the rack if the rack is moved (for example, if the rack is repositioned or relocated to another room).

5. Secure the instrument to the rack:
 - a. Select four of the appropriate screws for your equipment rack from the kit; 10-32, 12-24, M5, or M6.
 - b. Secure the instrument in the rack using the screws selected in part a of this step, with the recessed washers and flat washers as shown in Figure 18.

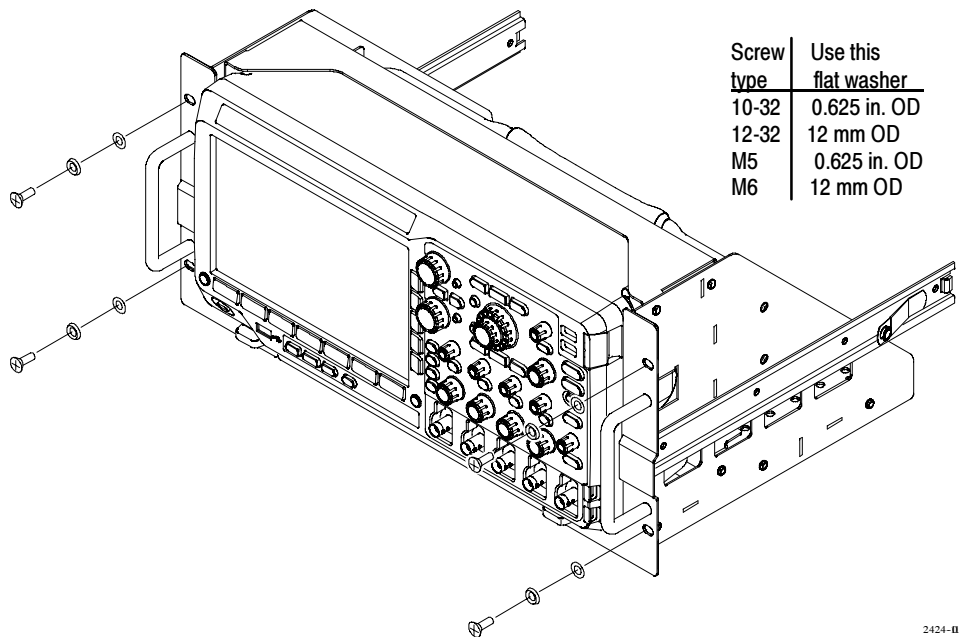

2424-01

Figure 18: Securing the instrument to the rack

❏ End of document ❏

X-ON Electronics

Largest Supplier of Electrical and Electronic Components

Click to view similar products for [Test Accessories - Other category](#):

Click to view products by [Tektronix manufacturer](#):

Other Similar products are found below :

[AO1026](#) [AO1035](#) [AO1051](#) [AO1059](#) [149116](#) [149118](#) [RS40](#) [RS41](#) [AO1030](#) [AO1032](#) [AO1036](#) [AO1058](#) [4742](#) [KTS288540](#) [11-32-2733](#)
[00415](#) [00163](#) [PACC-ZD005](#) [PACC-ZD007](#) [700M20TH](#) [628824000](#) [MPT-VF](#) [B3](#) [15010A0A0100M0](#) [B3](#) [15050A0D01A2M0](#) [B3](#)
[1505A00A01A1M0](#) [B3](#) [15060A0D0100M0](#) [98-CAL020](#) [MO-SCREEN](#) [68-020-01P](#) [CVRF02](#) [CPAK8](#) [RT-ZA19](#) [LCR-OPT-02](#) [1-1437358-1](#)
[4408](#) [POMONA](#) [DME D110 T1](#) [LMLH 50](#) [FLUKE PM9082/001](#) [85392-12](#) [ST18/SMAM/SMAM/72](#) [HO720](#) [BNC PROBES 310-064](#) [45025](#)
[45028](#) [CT2300](#) [CC545](#) [VT-1000](#) [CT3041](#) [VS-AVT-CABLE-08](#) [6172A](#)