

Part Number	Description
E3P2G48D25	25A, 600 Vac
E3P2G48D50	50A, 600 Vac
E3P2G48D75	75A, 600 Vac
E3P2G48D75-16	75A, 520 Vac

### Part Number Explanation

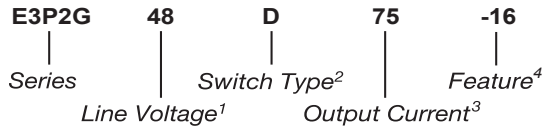

### NOTES

- 1) Line Voltage (nominal): 48 = 480 Vac
- 2) Switch Type: D = Zero-cross turn-on
- 3) Output Current: 25 = 25Amps,  
50 = 50 Amps  
75 = 75Amps
- 4) Features: -16 = RC+VDR

### Mechanical Specification

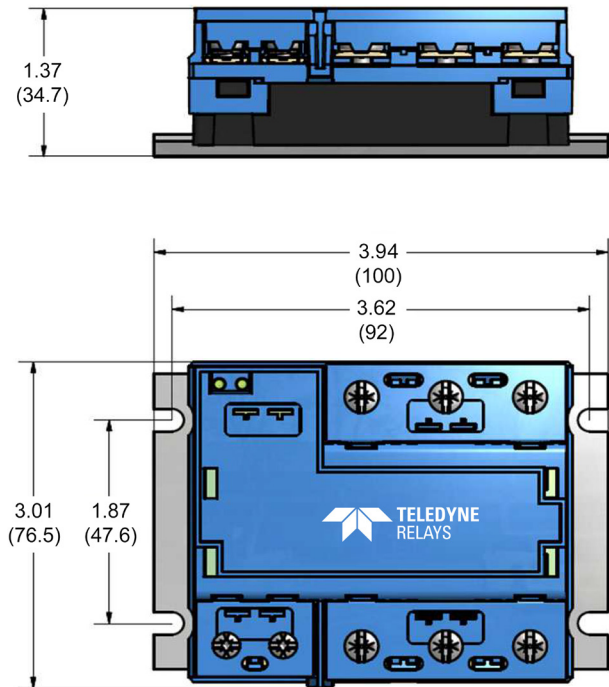

Figure 1 — Outline dimensions in inches (mm)

**Housing Material** — PA 6 UL94VO  
**Base Plate** — Tin plated Aluminum



### FEATURES / BENEFITS

- Three-phase power output
- Direct Copper Bonding
- Internal Over-Voltage protection
- Input Control LED
- Built in IP20 protection with flaps
- Excellent thermal performance
- Designed too IEC/ EN60947-4-3.
- High immunity to surges

### DESCRIPTION

The E3P2G series, three-phase solid state relay is the 2nd generation of the discontinued E3P series. The new design incorporates a high efficiency back-to-back thyristor with direct copper bonding for a longer lifetime expectancy. Over-Voltage protection is provided internally with TVS diodes for the input and output. Additionally our -16 model is designed with an RC snubber and VDR for greater protection to the output to handle all types of loads. The industrial SSR utilizes optical isolation to protect the control from load transients for each phase and has tight zero-cross window for low EMI. A control status LED are standard on all models.

### APPLICATIONS

- Heating control
- Motor control
- Uninterruptible power supplies
- Light dimmers
- Three-phase industrial and process control
- On/Off controls of AC equipment

### APPROVALS

Conformity to IEC947-4-3  
UL Pending

**INPUT (CONTROL) SPECIFICATION**

	Min	Typ.	Max	Units
Control Voltage	4		30	Vdc
Control Current			25	mA
Must Turn-Off Voltage	2			Vdc
Input Resistance	Current Regulator			Ω
Reverse Voltage Protection		30		V

**OUTPUT (LOAD) SPECIFICATION**

	Min	Typ.	Max	Units
<b>Operating Voltage Range (+/- 10%)</b>				
E3P2G48DXX	24	400	600	V <sub>rms</sub>
E3P2G48D75-16	24	400	520	V <sub>rms</sub>
<b>Peak Voltage</b>				
E3P2G48D25			1200	V <sub>peak</sub>
E3P2G48D50			1200	V <sub>peak</sub>
E3P2G48D75			1200	V <sub>peak</sub>
E3P2G48D75-16			1600	V <sub>peak</sub>
<b>Latching Voltage</b>				
All relays			10	V
<b>Load Current Range (@40 °C)<sup>1</sup></b>				
25A output current	.005		25	A <sub>rms</sub>
50A output current	.005	42	50	A <sub>rms</sub>
75A output current	.005	54	75	A <sub>rms</sub>
<b>Non-Repetitive Overload Current (tp=10ms)</b>				
25A output	320	420		A
50A output	700	750		A
75A output	1100	1200		A
<b>On-State Voltage Drop (@ 25°C)</b>				
E3P2G48D25			0.85	V
All other relays			1	V
<b>On State Dynamic Resistance</b>				
25A output			9.5	mΩ
50A output			7.5	mΩ
75A output			4.5	mΩ
<b>Zero-Cross Window</b>				
E3P2G48D25			35	V
E3P2G48D50		30		V
E3P2G48D75-XX	10			V

**CONTROL CHARACTERISTIC**

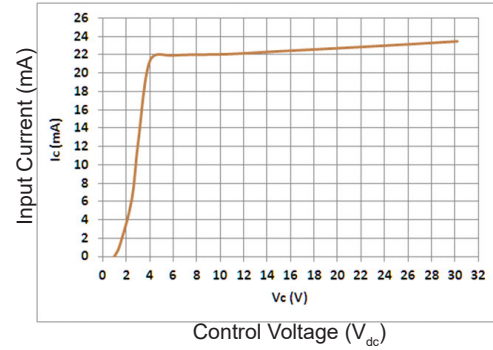

**Typical Application**

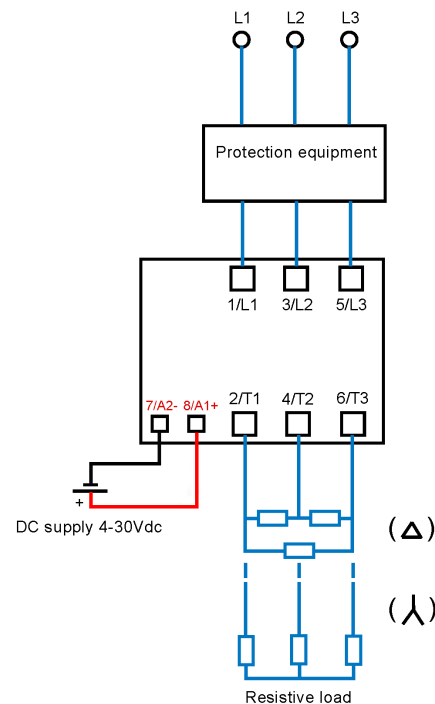

**Figure 2 — Wiring Diagram**

**OUTPUT (LOAD) SPECIFICATION (Continued)**

	Min	Typ.	Max	Units
<b>Junction-Case Thermal Resistance</b>				
25A output current		0.50		°C/W
50A output current		0.45		°C/W
75A output current		0.30		°C/W
<b>Off-State Leakage Current (50 Hz)</b>				
All relays			1	mA
<b>Turn-On Time (50 Hz)</b>				
All relays		10		ms
<b>Turn-Off Time (50 Hz)</b>				
All relays		10		ms
<b>Off-State dv/dt</b>				
All relays	500			V/μs
<b>Maximum di/dt (Non-Repetitive)</b>				
All relays			50	A/μs
<b>Operating Frequency Range</b>				
All relays	0.1	50-60	400	Hz
<b>I<sup>2</sup>t for Match Fusing (&lt;10ms)</b>				
25A output	512	882		A <sup>2</sup> s
50A output	2450	2800		A <sup>2</sup> s
75A output	6000	7200		A <sup>2</sup> s

**ENVIRONMENTAL SPECIFICATION**

	Min	Typ.	Max	Units
<b>Operating Temperature</b>				
E3P2G48DXX	-40		100	°C
E3P2G48D75-16	-40		85	°C
<b>Storage Temperature<sup>2</sup></b>				
All relays	-40		125	°C
<b>Input-Output Isolation</b>		4000		V <sub>rms</sub>
<b>Output-Case Isolation</b>		4000		V <sub>rms</sub>
<b>Isolation Resistance (@500V<sub>dc</sub>)</b>		1000		MΩ
<b>Vibration (IEC60068-2-6)<sup>3</sup></b>		1.5		mm
<b>Shock (IEC60068-2-6)</b>	30		50	g's
<b>Protection Level</b>		IP20		
<b>Relative Humidity</b>	40		85	%
<b>Weight</b>		200		g

**Notes**

- <sup>1</sup>With Heatsink
- <sup>2</sup>10-150Hz, double amplitude
- <sup>3</sup>No icing, no condensation

**BLOCK DIAGRAMS**

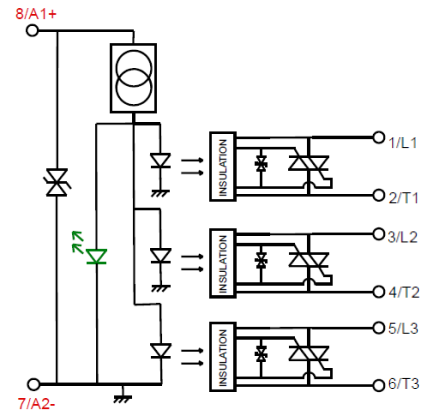

Figure 4a — E3P2G48DXX

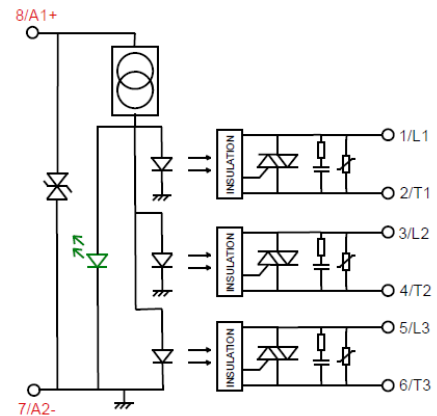
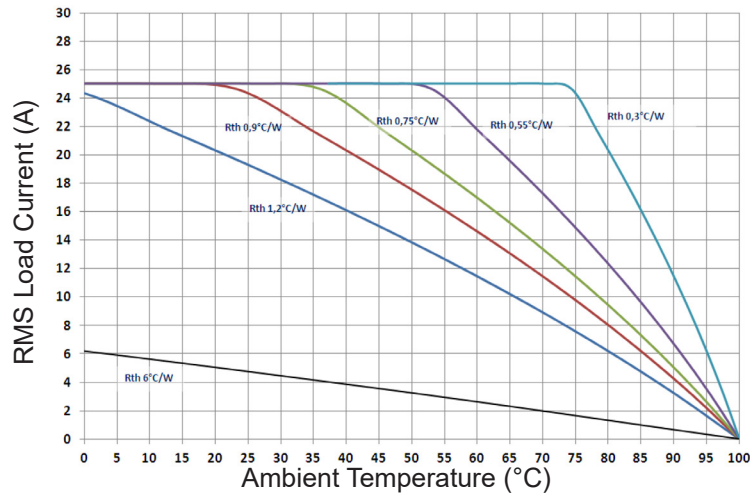

Figure 4b — E3P2G48DXX-16

**THERMAL CHARACTERISTICS**

**Figure 5a — 25A output**



**Figure 5b — 50A output**

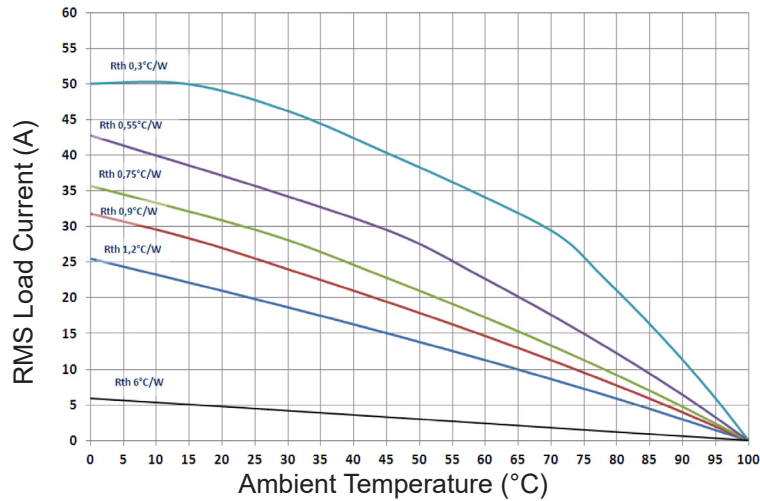

**Figure 5c — 75A output**

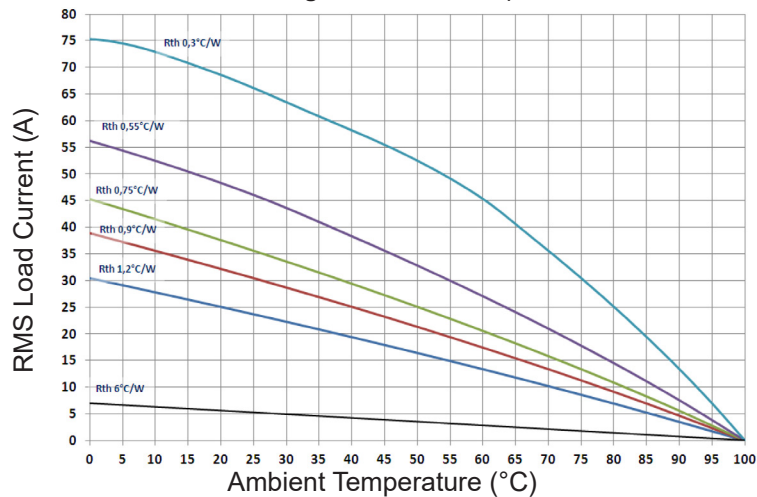

**SURGE CURRENT**

Curve Definitions

- 1: **Non Repetative** - is given without voltage reapplied. This curve is used to define the protection (fuses).
- 2: **Repetative** - is given for inrush current with initial  $T_j = 70^\circ\text{C}$ . In normal operation, this curve mustn't be exceeded.  
Caution, frequent over load currents will decrease the life expectancy of the SSR.

Figure 6a— 25A output

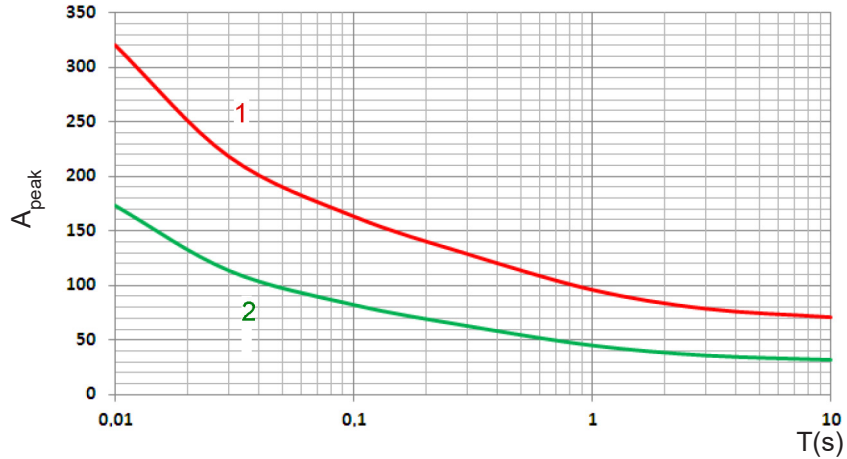

Figure 6b— 50A output

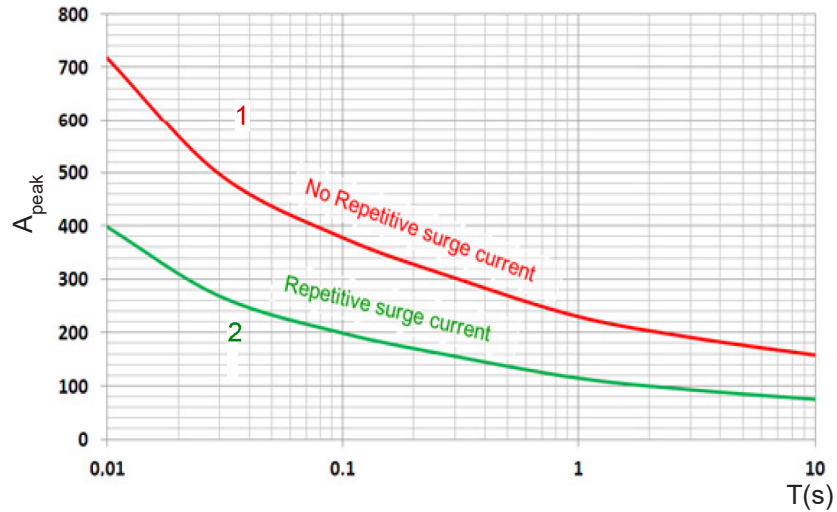
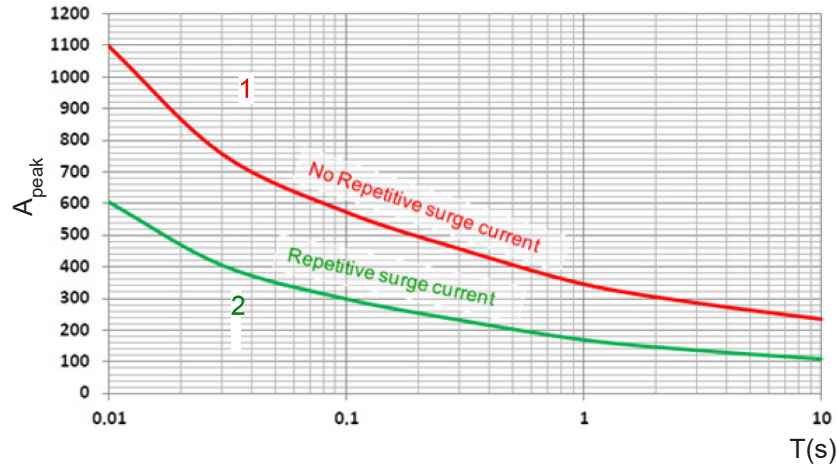

Figure 6c— 75A output



## CONNECTIONS

Direct connection with wires  
with or without ferrules



With ring terminals



Control Wiring				
Number of wires				Screwdriver type
1		2		
SOLID (No ferrule)	FINE STRANDED (With ferrule)	SOLID (No ferrule)	FINE STRANDED (With ferrule)	POZIDRIV 2
AWG18 -- AWG14 0.75 -- 2.5 mm <sup>2</sup>	AWG18 -- AWG14 0.75 -- 2.5 mm <sup>2</sup>	AWG18 -- AWG14 0.75 -- 2.5 mm <sup>2</sup>	AWG18 -- AWG14 0.75 -- 2.5 mm <sup>2</sup>	Recommended tightening torque for M4 screw: Min 1.2 / Typ 1.5 / Max 2 N.M

Power Wiring				
Number of wires				Screwdriver type
1		2		
SOLID (No ferrule)	FINE STRANDED (With ferrule)	SOLID (No ferrule)	FINE STRANDED (With ferrule)	POZIDRIV 2
AWG16 -- AWG8 1.5 -- 10 mm <sup>2</sup>	AWG16 -- AWG8 1.5 -- 10 mm <sup>2</sup>	AWG16 -- AWG8 1.5 -- 10 mm <sup>2</sup>	AWG16 -- AWG8 1.5 -- 10 mm <sup>2</sup>	Recommended tightening torque for M5 screw: Min 2 / Typ 2.4 / Max 3 N.M

**Power with ring terminal**

W max = 12.6mm  
 AWG6 (16 mm<sup>2</sup>)  
 AWG4 (25 mm<sup>2</sup>)  
 AWG2 / AWG3 (35mm<sup>2</sup>)  
 AWG0 / AWG1 (50mm<sup>2</sup>)

**IP20 flaps**

Flaps are delivered mounted on the relay. Marking labels are available for mounting on flaps.

## X-ON Electronics

Largest Supplier of Electrical and Electronic Components

*Click to view similar products for [Solid State Relays - Industrial Mount](#) category:*

*Click to view products by [Teledyne](#) manufacturer:*

Other Similar products are found below :

[D2440-C](#) [H10CA4890](#) [H10CD4890](#) [D4840B](#) [D4875C](#) [1395831-1](#) [SE-K4EN](#) [A-1326](#) [H10CA4850](#) [H12CA4890VL](#) [RA2410-D06](#)  
[RA2410HA06T](#) [TD1205](#) [D53TP50-10](#) [W230E-1-12](#) [W230T-3-12](#) [1-1617030-3](#) [MS2-D2420](#) [MS2-D2430](#) [A-1440](#) [G3TAOD201SDC24](#) [1-](#)  
[1617033-0](#) [G3SD-Z01P-PE](#) [DC24](#) [SMT8628521](#) [ESUC0480](#) [SRH3-1440R](#) [XKA70420](#) [G3PH-5150BAC100-240](#) [GN325DSZH](#)  
[GN350ASZH](#) [GN325ASZH](#) [GN350DSZH](#) [1109564](#) [G3NB-225B-1](#) [DC5-24](#) [GNRD06CDL](#) [GN325DSRH](#) [GNR25DCZH](#) [52511](#) [CWH-62-](#)  
[WO](#) [E-1048-8I4-C3D4V1-4U3-10A](#) [E-1048-8I4-C3D1V0-4U3-5A](#) [RGC1P60CM25KEN](#) [48ATE3S00X204](#) [48BTG3S00X204](#) [GNR25ACZH](#)  
[RA4025H10PCS](#) [RKD2A60D50P](#) [RK2A60D50P](#) [RK2A60D75P](#) [PVG612](#)