

# SHC

## AC Output SSR with LED & Built-in Varistor



### Description

The industrial, Single-Phase Relay with antiparallel thyristor output is the most widely used industrial SSR due to its multiple application possibilities. The relay can be used for resistive, inductive and capacitive loads offering both Zero-Cross and Random switching. With Zero-Cross switching the relay switches ON when the sinusoidal curve crosses zero and switches OFF when the current crosses zero. With Random Turn-on relay with DC control input can be used for phase control. The built-in varistor secures transient protection for the heavy industrial applications, and the LED indicates the status of the control input. The clip-on cover is securing touch protection to IP 20. Protected output terminals can handle cables up to 16mm

### Features

- Zero Cross or Random Turn-on switching
- Direct copper bonding (DCB) technology
- LED indication
- Built-in varistor
- Clip-on IP 20 protection cover
- Self-lifting terminals
- Housing free of moulding mass
- 2 input ranges: 3-32\* VDC and 20-280VAC/22-48VDC
- Operational ratings: Up to 100AACrms and 600VACrms
- Blocking voltage: Up to 1400V<sub>p</sub>

### Part Numbering System

Code	Option	Description	Notes*
SHC		Product Series	
-	23	Operational Voltage Range: 24-265 VACrms (230V Nom.)	42-265 VACrms for Random Turn-On models
-	48	Operational Voltage Range: 42-530 VACrms (480V Nom.)	
-	60	Operational Voltage Range: 42-660 VACrms (600V Nom.)	
-	D	Zero Cross, Control Voltage: 4-32 VDC*	3-32 VDC for SHC23.. models
-	A	Zero Cross, Control Voltage: 20-280 VAC, 22-48 VDC	
-	R	Random Turn-On, Control Voltage: 4-32 VDC	
-	E	Random Turn-On, Control Voltage: 20-280 VAC, 22-48 VDC	
-	25	Rated Load Current: 25A	
-	50	Rated Load Current: 50A	
-	75	Rated Load Current: 75A	
-	100	Rated Load Current: 100A	

Example: **SHC 60 D 100**



## General Specifications

	SHC23...	SHC48...	SHC60...
<b>Operational Voltage Range</b>	24 to 265 VACrms	42 to 530 VACrms	42 to 660 VACrms
Zero-Cross	42 to 265 VACrms	42 to 530 VACrms	42 to 660 VACrms
Random Turn-On			
<b>Blocking Voltage</b>	650 Vp	1200 Vp	1400 Vp
<b>Zero Voltage Turn-On</b>	≤ 10 V	≤ 10 V	≤ 10 V
<b>Operational Frequency Range</b>	45 to 65 Hz	45 to 65 Hz	45 to 65 Hz
<b>Power factor</b>	> 0.5 @ 230 VACrms	> 0.5 @ 480 VACrms	> 0.5 @ 600 VACrms
<b>Approvals</b>	UR, cUR, CSA	UR, cUR, CSA	UR, cUR, CSA
<b>CE-marking</b>	Yes	Yes	Yes*
<b>UKCA Marking</b>	Yes	Yes	Yes*
<b>Isolation</b>			
Input to Output	4000 Vrms	4000 Vrms	4000 Vrms
Input and Output to Case	4000 Vrms	4000 Vrms	4000 Vrms

\*Heatsink must be connected to ground

## Input Specifications

Input Type	DC Input	AC Input
<b>Control Voltage Range</b>	4 - 32 VDC <sup>1</sup>	20 - 280 VAC, 22 - 48 VDC
<b>Pick-Up Voltage @ Ta = 25° C</b>		
SHC23.. (Zero-Cross)	2.5 VDC	18 VAC/DC
All other Zero-Cross Models	3.5 VDC	18 VAC/DC
All Random Turn-On Models	3.5 VDC	18 VAC/DC
<b>Reverse Voltage</b>	32 VDC	-
<b>Drop-Out Voltage</b>	1.2 VDC	6 VAC/DC
<b>Input Current @ Max Input Voltage</b>		
Zero-Cross	≤12 mA	≤20 mA
Random Turn-On	≤15 mA	≤20 mA
<b>Response Time Pick-Up</b>		
Zero-Cross	≤1/2 cycle	≤12 ms
Random Turn-On	≤0.1 ms	≤12 ms
<b>Response Time Drop-Out</b>		
Zero-Cross	≤1/2 cycle	≤40 ms
Random Turn-On	≤1/2 cycle	≤40 ms

1. 3-32VDC for SHC23D.. models only

## Output Specifications

	SHC...25	SHC...50	SHC...75	SHC...100
<b>Max. Operational Current:</b> AC51 @ Ta=25°C AC53 @ Ta=25°C	25 Arms 5 Arms	50 Arms 15 Arms	75 Arms 20 Arms	100 Arms 30 Arms
<b>Min. Operational Current</b>	150 mA	250 mA	400 mA	500 mA
<b>Repetitive Overload Current; t=1 s</b>	< 55 AACrms	< 125 AACrms	< 150 AACrms	< 200 AACrms
<b>Non-repetitive Surge Current; t=10 ms</b>	325A <sub>p</sub>	600A <sub>p</sub>	1150A <sub>p</sub>	1900A <sub>p</sub>
<b>Off-State Leakage Current @ Rated Voltage and Frequency</b>	<3 mArms	<3 mArms	<3 mArms	<3 mArms
<b>I<sup>2</sup>t for Fusing (t=10 ms)</b>	< 525 A <sup>2</sup> s	< 1800 A <sup>2</sup> s	< 6600 A <sup>2</sup> s	< 18000 A <sup>2</sup> s
<b>Critical dV/dt Off-State Min</b>	1000 V/μs	1000 V/μs	1000 V/μs	1000 V/μs
<b>Endurance Testing acc. to UL508</b>	100,000 cycles	100,000 cycles	100,000 cycles	6,000 cycles

## Motor Ratings: HP (UL508)

	230VAC	480VAC	600VAC
<b>SHC..25</b>	1.5HP	3HP	5HP
<b>SHC..50</b>	3HP	7.5HP	10HP
<b>SHC..75</b>	5HP	10HP	15HP
<b>SHC..100</b>	7.5HP	20HP	25HP

## Electromagnetic Compatibility

<b>EMC Immunity</b>	EN60947-4-3	<b>Radiated Radio Frequency Immunity</b>	IEC/EN 61000-4-3
Electrostatic Discharge (ESD) Immunity	IEC/EN 61000-4-2	10V/m, 80 - 1000 MHz	Performance Criteria 1
Air discharge, 8kV	Performance Criteria 2	10V/m, 1.4 - 2.0GHz	Performance Criteria 1
Contact, 4kV	Performance Criteria 2	3 V/m, 2.0 - 2.7GHz	Performance Criteria 1
<b>Electrical Fast Transient (Burst) Immunity</b>	IEC/EN 61000-4-4	<b>Conducted Radio Frequency Immunity</b>	IEC/EN 61000-4-6
Output: 2kV, 5kHz	Performance Criteria 1	10V/m, 0.15 - 80 MHz	Performance Criteria 1
Input: 1kV, 5kHz	Performance Criteria 1	<b>Voltage Dips Immunity</b>	IEC/EN 61000-4-11
<b>Electrical Surge Immunity</b>	IEC/EN 61000-4-5	0% for 0.5, 1 cycle	Performance Criteria 2
Output, line to line, 1kV	Performance Criteria 2	40% for 10 cycles	Performance Criteria 2
Output, line to earth, 1kV	Performance Criteria 2	70% for 25 cycles	Performance Criteria 2
Output, line to earth, 2kV	Performance Criteria 2 with external varistor	80% for 250 cycles	Performance Criteria 2
Input, line to line, 1kV	Performance Criteria 2	<b>Voltage Interruptions Immunity</b>	IEC/EN 61000-4-11
Input, line to earth, 2kV	Performance Criteria 2	0% for 5000ms	Performance Criteria 2
<b>EMC Emission</b>	EN60947-4-3	<b>Radio Interference Field Emission (Radiated)</b>	IEC/EN 55011
<b>Radio Interference Voltage Emission (Conducted)</b>	IEC/EN 55011	<b>30 - 1000MHz</b>	Class B
<b>0.15 - 30MHz</b>	Class A (industrial) with external filters		

**Notes:**

- Use of AC solid state relays may, according to the application and the load current, cause conducted radio interferences. Use of mains filters may be necessary for cases where the user must meet E.M.C requirements. The capacitor values given inside the filtering specification tables should be taken only as indications, the filter attenuation will depend on the final application.
- The control terminals A1, A2 (SHC..A or E) shall be supplied by a secondary circuit where power is limited by a transformer, rectifier, voltage divider, or similar device that derives power from a primary circuit, and where the short-circuit limit between conductors of the secondary circuit or between conductors and ground is 1500 VA or less. The short-circuit volt ampere limit is the product of the open circuit voltage and the short circuit ampere.
- Control input lines must be installed together to maintain products' susceptibility to Radio Frequency interference.
- Performance Criteria 1: No degradation of performance or loss of function is allowed when the product is operated as intended.
- Performance Criteria 2: During the test, degradation of performance or partial loss of function is allowed. However, when the test is complete the product should return operating as intended by itself.
- Performance Criteria 3: Temporary loss of function is allowed, provided the function can be restored by manual operation of the controls.

## Housing Specifications

<b>Models</b> 25A, 50A 75A, 100A	<b>Weight</b> Approx. 60g Approx. 100g
<b>Models</b> 25A, 50A 75A, 100A	<b>Baseplate</b> Aluminium Copper, nickel-plated
<b>Potting Compound</b>	None
<b>Relay</b> Mounting Screws Mounting Torque	M5 1.5-2.0Nm

## Connection Specifications

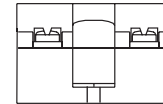
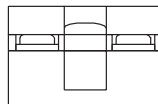
**Connection terminals**
**L1, T1**
**A1, A2**

**Stripping length (X)**

12 mm

8 mm

**Connection Type**

M5 screw with captivated washer

M3 screw with captivated washer

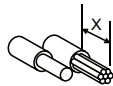
**Rigid (solid & stranded)  
UR rated data**

1x 2.5 - 6.0 mm <sup>2</sup>	2x 2.5 - 6.0 mm <sup>2</sup>	1x 0.5 - 2.5 mm <sup>2</sup>	2x 0.5 - 2.5 mm <sup>2</sup>
1x 14 - 10 AWG	2x 14 - 10 AWG	1x 18 - 12 AWG	2x 18 - 12 AWG

**Flexible with end sleeve**

1x 1.0 - 4.0 mm <sup>2</sup>	2x 1.0 - 2.5 mm <sup>2</sup>	1x 0.5 - 2.5 mm <sup>2</sup>	2x 0.5 - 2.5 mm <sup>2</sup>
1x 18 - 12 AWG	2x 2.5 - 4.0 mm <sup>2</sup>	1x 18 - 12 AWG	2x 18 - 12 AWG
	2x 18 - 14 AWG		
	2x 14 - 12 AWG		

**Flexible without end sleeve**

1x 1.0 - 6.0 mm <sup>2</sup>	2x 1.0 - 2.5 mm <sup>2</sup>
1x 18 - 10 AWG	2x 2.5 - 6.0 mm <sup>2</sup>
	2x 18 - 14 AWG
	2x 14 - 10 AWG

**Torque specification**

 Pozidrive 2  
 2.4 Nm (21.2 lb-in)

 Pozidrive 1  
 0.5 Nm (4.4 lb-in)

**Aperture for termination lug**

12 mm

7.5 mm

**Functional Diagram**

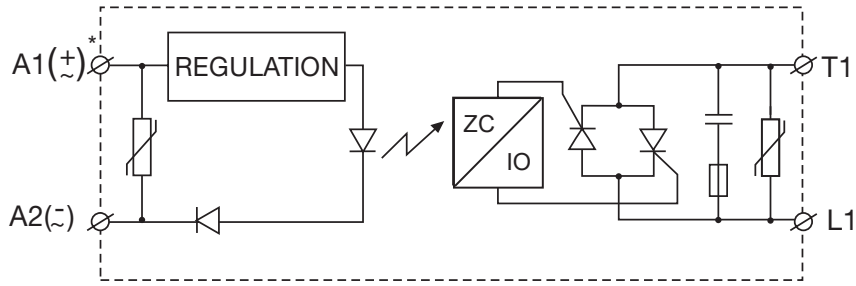

\* Varistor across input applies to AC control versions only.

**Dimensions**

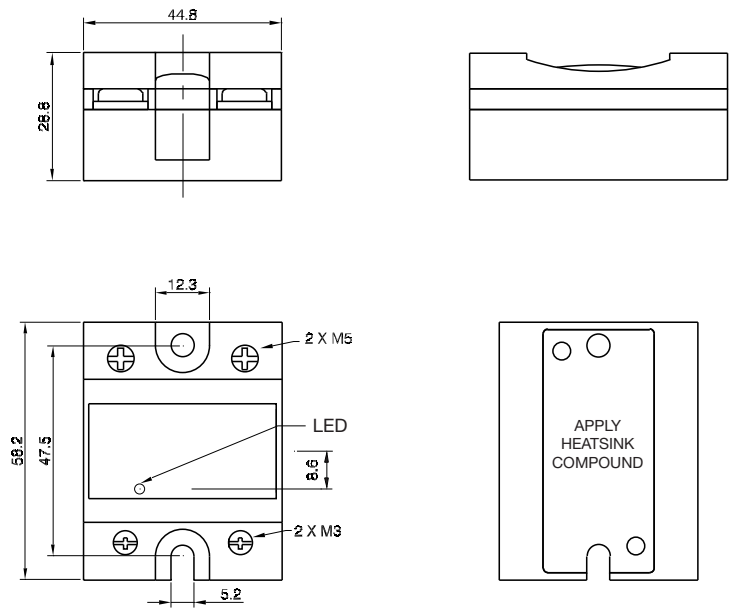

All dimensions in mm

**Connection Diagram**

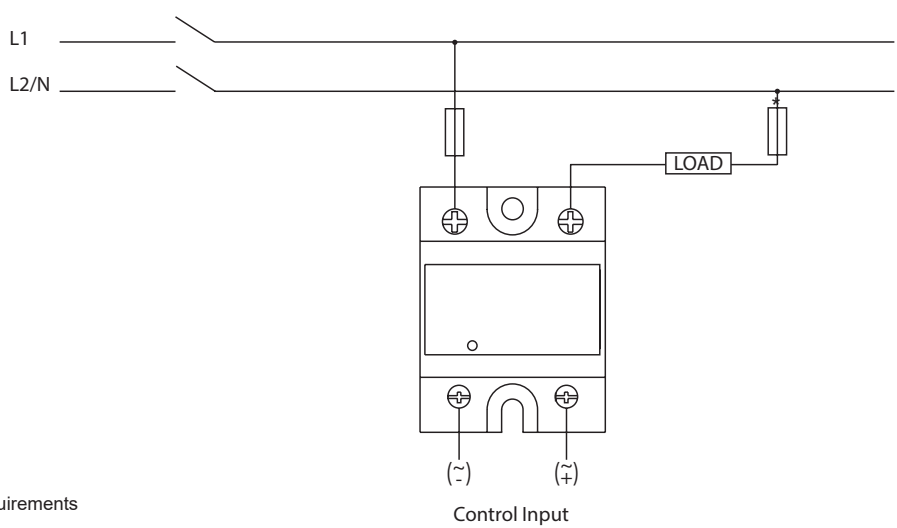

\* Depends on system requirements

**Output Power Dissipation**

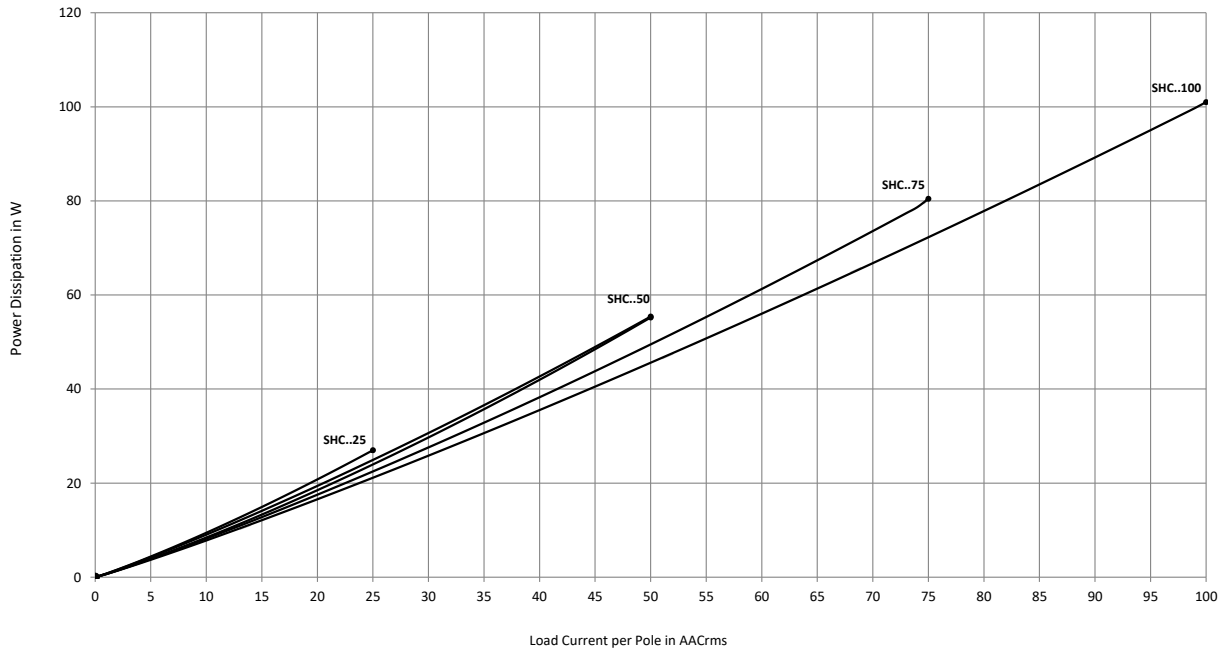

**Heatsink Dimensions (Load Current vs Ambient Temperature)**

**SHC..25**

Load Current (A)	Thermal Resistance (°C/W)					
	20	30	40	50	60	70
25.0	2.70	2.34	1.98	1.61	1.25	0.89
22.5	3.10	2.69	2.28	1.86	1.45	1.04
20.0	3.61	3.13	2.65	2.18	1.70	1.23
17.5	4.26	3.70	3.14	2.59	2.03	1.47
15.0	5.14	4.47	3.80	3.14	2.47	1.80
12.5	6.38	5.56	4.73	3.91	3.09	2.27
10.0	8.25	7.19	6.14	5.08	4.02	2.97
7.5	11.4	9.94	8.49	7.04	5.59	4.14
5.0	17.7	15.4	13.2	11.0	8.74	6.51
2.5	-	-	-	-	18.2	13.6

**SHC..50**

Load Current (A)	Thermal Resistance (°C/W)					
	20	30	40	50	60	70
50.0	1.03	0.86	0.70	0.53	0.37	0.20
45.0	1.27	1.32	0.90	0.71	0.52	0.33
40.0	1.54	1.59	1.10	0.89	0.67	0.45
35.0	1.85	1.95	1.34	1.08	0.82	0.57
30.0	2.26	2.47	1.65	1.34	1.03	0.72
25.0	2.85	3.24	2.08	1.70	1.32	0.94
20.0	3.73	3.24	2.75	2.26	1.77	1.27
15.0	5.22	4.54	3.86	3.19	2.51	1.83
10.0	8.21	7.16	6.11	5.05	4.00	2.95
5.0	17.2	15.0	12.9	10.7	8.51	6.33

Junction to ambient thermal resistance, $R_{th\ j-a}$	< 20.0	°C/W
Junction to case thermal resistance, $R_{th\ j-c}$	< 0.80	°C/W
Case to heatsink thermal resistance, $R_{th\ c-s}^2$	< 0.20	°C/W
Maximum allowable case temperature	100	°C
Maximum allowable junction temperature	125	°C

Junction to ambient thermal resistance, $R_{th\ j-a}$	< 20.0	°C/W
Junction to case thermal resistance, $R_{th\ j-c}$	< 0.50	°C/W
Case to heatsink thermal resistance, $R_{th\ c-s}^2$	< 0.20	°C/W
Maximum allowable case temperature	100	°C
Maximum allowable junction temperature	125	°C

**SHC..75**

Load Current (A)	Thermal Resistance (°C/W)					
	20	30	40	50	60	70
75.0	0.91	0.78	0.65	0.52	0.39	0.26
67.5	1.10	0.96	0.81	0.66	0.51	0.36
60.0	1.34	1.17	1.00	0.83	0.66	0.49
52.5	1.60	1.40	1.20	1.00	0.80	0.60
45.0	1.93	1.68	1.44	1.20	0.96	0.72
37.5	2.38	2.08	1.78	1.49	1.19	0.89
30.0	3.06	2.68	2.30	1.91	1.53	1.15
22.5	4.21	3.68	3.16	2.63	2.10	1.58
15.0	6.51	5.70	4.88	4.07	3.26	2.44
7.5	13.5	11.77	10.09	8.41	6.73	5.04

**SHC..100**

Load Current (A)	Thermal Resistance (°C/W)					
	20	30	40	50	60	70
100.0	0.54	0.45	0.36	0.27	0.18	0.09
90.0	0.68	0.58	0.47	0.37	0.27	0.17
80.0	0.86	0.74	0.62	0.50	0.38	0.26
70.0	1.08	0.94	0.80	0.66	0.52	0.38
60.0	1.37	1.20	1.03	0.85	0.68	0.51
50.0	1.70	1.49	1.28	1.06	0.85	0.64
40.0	2.21	1.93	1.66	1.38	1.10	0.83
30.0	3.06	2.68	2.30	1.91	1.53	1.15
20.0	4.78	4.18	3.59	2.99	2.39	1.79
10.0	9.98	8.73	7.49	6.24	4.99	3.74

Junction to ambient thermal resistance, $R_{th\ j-a}$	< 20.0	°C/W
Junction to case thermal resistance, $R_{th\ j-c}$	< 0.35	°C/W
Case to heatsink thermal resistance, $R_{th\ c-s}^2$	< 0.10	°C/W
Maximum allowable heatsink temperature	100	°C
Maximum allowable junction temperature	125	°C

Junction to ambient thermal resistance, $R_{th\ j-a}$	< 20.0	°C/W
Junction to case thermal resistance, $R_{th\ j-c}$	< 0.30	°C/W
Case to heatsink thermal resistance, $R_{th\ c-s}^2$	< 0.10	°C/W
Maximum allowable heatsink temperature	100	°C
Maximum allowable junction temperature	125	°C

## Thermal Specifications

	SHC...25	SHC...50	SHC60..50	SHC...75	SHC...100
Operating Temperature Range	-20° to 70°C	-20° to 70°C	-20° to 70°C	-20° to 70°C	-20° to 70°C
Storage Temperature Range	-40° to 100°C	-40° to 100°C	-40° to 100°C	-40° to 100°C	-40° to 100°C
Junction Temperature	≤ 125°C	≤ 125°C	≤ 125°C	≤ 125°C	≤ 125°C
$R_{th}$ Junction to Case	≤ 0.80°C/W	≤ 0.50°C/W	≤ 0.72°C/W	≤ 0.35°C/W	≤ 0.30°C/W
$R_{th}$ Junction to Ambient	≤ 20.0°C/W	≤ 20.0°C/W	≤ 20.0°C/W	≤ 20.0°C/W	≤ 20.0°C/W

## Short Circuit Protection

### Protection Co-ordination, Type 1 vs. Type 2:

Type 1 protection implies that after a short circuit, the device under test will no longer be in a functioning state. In type 2 co-ordination the device under test will still be functional after the short circuit. In both cases, however, the short circuit has to be interrupted. The fuse between enclosure and supply shall not open. The door or cover of the enclosure shall not be blown open. There shall be no damage to conductors of terminals and the conductors shall not separate from terminals. There shall be no breakage or cracking of insulating bases to the extent that the integrity of the mounting of live parts is impaired. Discharge of parts or any risk of fire shall not occur.

The product variants listed in the table hereunder are suitable for use on a circuit capable of delivering not more than 65,000A rms Symmetrical Amperes, 600Volts maximum when protected by fuses. Tests at 65,000A were performed with Class J, fast acting; please refer to the table below for maximum allowed ampere rating of the fuse. Use fuses only.

### Co-ordination Type 1 (UL508)

Part No.	Prospective short circuit current (kArms)	Max. fuse size (A)	Class/ Model	Voltage (VAC)
SHC..25	65	30	J or CC	600
SHC..50	65	30	J	600
		20	HSJ20 (Mersen*)	600
SHC..75	65	80	J	600
		60	HSJ60 (Mersen*)	600
SHC..100	65	80	J	600
		60	HSJ60 (Mersen*)	600

### Co-ordination Type 2 (IEC/EN60947-4-3)

Part No.	Prospective short circuit current (kArms)	Max. fuse size (A)	Brand	Model	Size
SHCxx.25 (xx = 23, 40, or 48)	10	25	Mersen*	6.9 gRB 10-25	10.3 x 38
SHCxx.50 (xx = 23 or 40)	10	50	Mersen*	6.9zz CP gRC 14x51/50	14 x 51
SHCxx.50 (xx = 48 or 60)	10	50	Mersen*	6.9zz CP gRC 22x58/50	22 x 58
SHCxx.75 (xx = 23, 40, 48, 60)	10	63	Mersen*	6.9zz CP gRC 22x58/63	22 x 58
SHCxx.100 (xx = 23 or 40)	10	100	Mersen*	6.9zz CP gRC 22x58/100	22 x 58

zz = 00, without fuse trip indication

zz = 21, with fuse trip indication

\* Formerly Ferraz Shawmut



## Type 2 Protection with Miniature Circuit Breakers (M.C.B.S)

Solid State Relay type	ABB Model no. for Z - type M. C. B. (Rated Current)	ABB Model no. for B - type M. C. B. (Rated Current)	Wire cross sectional area (mm <sup>2</sup> )	Minimum length of Cu wire conductor (m)*	
<b>SHC..25</b>	<b>1-pole</b>				
	S201-Z4 (4A)	S201-B2 (2A)	1.0	21.0	
	S201-Z6 UC (6A)	S201-B2 (2A)	1.0	21.0	
			1.5	31.5	
<b>SHC..50..</b>	<b>1-pole</b>				
	S201-Z10 (10A)	S201-B4 (4A)	1.0	7.6	
			1.5	11.4	
			2.5	19.0	
	S201-Z16 (16A)	S201-B6 (6A)	1.0	5.2	
			1.5	7.8	
			2.5	13.0	
			4.0	20.8	
	S201-Z20 (20A)	S201-B10 (10A)	1.5	12.6	
			2.5	21.0	
	S201-Z25 (25A)	S201-B13 (13A)	2.5	25.0	
			4.0	40.0	
		<b>2-pole</b>			
		S202-Z25 (25A)	S202-B13 (13A)	2.5 4.0	19.0 30.4
<b>SHC..75</b>	<b>1-pole</b>				
	S201-Z20 (20A)	S201-B10 (10A)	1.5	4.2	
			2.5	7.0	
			4.0	11.2	
	S201-Z32 (32A)	S201-B16 (16A)	2.5	13.0	
			4.0	20.8	
			6.0	31.2	
	<b>2-pole</b>				
	S202-Z20 (20A)	S202-B10 (10A)	1.5	1.8	
			2.5	3.0	
			4.0	4.8	
	S202-Z32 (32A)	S202-B16 (16A)	2.5	5.0	
			4.0	8.0	
			6.0	12.0	
10.0			20.0		
S202-Z50 (50A)	S202-B25 (25A)	4.0	14.8		
		6.0	22.2		
		10.0	37.0		
<b>SHC..100</b>	<b>1-pole</b>				
	S201-Z50 (50A)	S201-B25 (25A)	4.0	4.8	
			6.0	7.2	
			10.0	12.0	
			16.0	19.2	
	S201-Z63 (63A)	S201-B32 (32A)	6.0	7.2	
			10.0	12.0	
16.0			19.2		

\* Between MCB and Load (including return path which goes back to the mains).

Note: A prospective current of 6kA and a 230/400V power supply system is assumed for the above suggested specifications. For cables with different cross section than those mentioned above please consult Teledyne Relays' Technical Support Group.

## Environmental Information

The declaration in this section is prepared in compliance with People's Republic of China Electronic Industry Standard SJ/T11364-2014: Marking for the Restricted Use of Hazardous Substances in Electronic and Electrical Products.

Part Name	Toxic or Harardous Substances and Elements					
	Lead (Pb)	Mercury (Hg)	Cadmium (Cd)	Hexavalent Chromium (Cr(VI))	Polybrominated biphenyls (PBB)	Polybrominated diphenyl ethers (PBDE)
Power Unit Assembly	x	○	○	○	○	○

O: Indicates that said hazardous substance contained in homogeneous materials for this part are below the limit requirement of GB/T 26572.

X: Indicates that said hazardous substance contained in one of the homogeneous materials used for this part is above the limit requirement of GB/T 26572.



Questions? Contact us at:

<https://www.teledynedefenseelectronics.com/relays/contactus/Pages/Contact-Us.aspx>

## X-ON Electronics

Largest Supplier of Electrical and Electronic Components

*Click to view similar products for [Solid State Relays - Industrial Mount](#) category:*

*Click to view products by [Teledyne](#) manufacturer:*

Other Similar products are found below :

[D2440-C](#) [H10CA4890](#) [H10CD4890](#) [D4840B](#) [D4875C](#) [1395831-1](#) [SE-K4EN](#) [A-1326](#) [H10CA4850](#) [H12CA4890VL](#) [RA2410-D06](#)  
[RA2410HA06T](#) [TD1205](#) [D53TP50-10](#) [W230E-1-12](#) [W230T-3-12](#) [1-1617030-3](#) [MS2-D2420](#) [MS2-D2430](#) [A-1440](#) [G3TAOD201SDC24](#) [1-](#)  
[1617033-0](#) [G3SD-Z01P-PE](#) [DC24](#) [SMT8628521](#) [ESUC0480](#) [SRH3-1440R](#) [XKA70420](#) [G3PH-5150BAC100-240](#) [GN325DSZH](#)  
[GN350ASZH](#) [GN325ASZH](#) [GN350DSZH](#) [1109564](#) [G3NB-225B-1](#) [DC5-24](#) [GNRD06CDL](#) [GN325DSRH](#) [GNR25DCZH](#) [52511](#) [CWH-62-](#)  
[WO](#) [E-1048-8I4-C3D4V1-4U3-10A](#) [E-1048-8I4-C3D1V0-4U3-5A](#) [RGC1P60CM25KEN](#) [48ATE3S00X204](#) [48BTG3S00X204](#) [GNR25ACZH](#)  
[RA4025H10PCS](#) [RKD2A60D50P](#) [RK2A60D50P](#) [RK2A60D75P](#) [PVG612](#)