Datasheet for Telink

2.4GHz RF SoC TLSR8367

DS-TLSR8367-E2

Ver 0.8.1

2020/11/17

Keyword:

2.4GHz; Features; Package; Pin layout; Memory; MCU;
Working modes; Wakeup sources; RF Transceiver;
Baseband; Clock; Timers; Interrupt; Interface; PWM;
QDEC; ADC; PGA; AES; Electrical specification

Brief:

This datasheet is dedicated for Telink 2.4GHz RF SoC TLSR8367. In this datasheet, key features, working mode, main modules, electrical specification and application of the TLSR8367 are introduced.



TELINK SEMICONDUCTOR

Published by
Telink Semiconductor

Bldg 3, 1500 Zuchongzhi Rd,
Zhangjiang Hi-Tech Park, Shanghai, China

© Telink Semiconductor
All Right Reserved

Legal Disclaimer

Telink Semiconductor reserves the right to make changes without further notice to any products herein to improve reliability, function or design. Telink Semiconductor disclaims any and all liability for any errors, inaccuracies or incompleteness contained herein or in any other disclosure relating to any product.

Telink Semiconductor does not assume any liability arising out of the application or use of any product or circuit described herein; neither does it convey any license under its patent rights, nor the rights of others

The products shown herein are not designed for use in medical, life-saving, or life-sustaining applications. Customers using or selling Telink Semiconductor products not expressly indicated for use in such applications do so entirely at their own risk and agree to fully indemnify Telink Semiconductor for any damages arising or resulting from such use or sale.

Information:

For further information on the technology, product and business term, please contact Telink Semiconductor Company (www.telink-semi.com).

For sales or technical support, please send email to the address of:

telinknsales@telink-semi.com

telinknsupport@telink-semi.com

Revision History

Version	Major Changes	Date	Author
0.8.0	Preliminary release	2019/8	LWF, SY, YHL, JF
0.8.1	1.Update deep and suspend current in 1.2.3 and Table 14-3 2. Update sensitivity data in 1.2.2 and Table 14-9	2020/11	LWF, YLJ,YH

1 Table of contents

1	Overview	8
1.1	Block diagram	8
1.2	Key features	8
1.2.1	General features	8
1.2.2	RF Features	9
1.2.3	Features of power management module.....	10
1.3	Typical application	11
1.4	Ordering information	11
1.5	Package	11
1.6	Pin layout	13
1.6.1	Pin layout for TLSR8367EP16.....	13
1.6.2	Notes.....	15
2	Memory and MCU	16
2.1	Memory	16
2.1.1	SRAM/Register	16
2.1.2	OTP	16
2.2	Firmware encryption	17
2.3	MCU	17
2.4	Working modes.....	17
2.4.1	Active mode.....	17
2.4.2	Idle mode.....	17
2.4.3	Power-saving mode	18
2.5	Reset	20
2.6	Power Management	21
2.6.1	Digital LDO	21
2.6.2	VBUS LDO.....	21
2.6.3	Power-On-Reset (POR) and Brown-out detect.....	21
2.6.4	Working mode switch.....	24
2.7	Wakeup sources	25

2.7.1	Wakeup source – 32kHz timer	25
2.7.2	Wakeup source – IO	25
2.7.3	Register table.....	25
3	2.4G RF Transceiver.....	27
3.1	Block diagram	27
3.2	Function description.....	28
3.2.1	Air interface data rate and RF channel frequency	28
3.3	Baseband	28
3.3.1	Packet format	28
3.3.2	RSSI and frequency offset.....	28
4	Clock.....	29
4.1	Clock sources	29
4.2	System clock	30
4.3	Module clock	30
4.3.1	System Timer clock.....	30
4.3.2	QDEC clock.....	30
4.4	Register table.....	31
5	Timers.....	32
5.1	Timer0~Timer2	32
5.1.1	Register table.....	32
5.1.2	Mode0 (System Clock Mode)	33
5.1.3	Mode1 (GPIO Trigger Mode)	33
5.1.4	Mode2 (GPIO Pulse Width Mode).....	34
5.1.5	Mode3 (Tick Mode)	35
5.1.6	Watchdog	36
5.2	32kHz LTIMER	36
5.3	System Timer	36
6	Interrupt System	39
6.1	Interrupt structure.....	39
6.2	Register configuration	39
6.2.1	Enable/Mask interrupt sources	40
6.2.2	Interrupt mode and priority	40

6.2.3	Interrupt source flag.....	41
7	Interface	42
7.1	GPIO.....	42
7.1.1	Basic configuration	42
7.1.1.1	GPIO lookup table.....	42
7.1.1.2	Multiplexed functions.....	46
7.1.1.3	Drive strength	47
7.1.2	Connection relationship between GPIO and related modules	47
7.1.3	Pull-up/Pull-down resistor.....	50
7.2	SWS.....	52
7.3	I2C.....	52
7.3.1	Communication protocol.....	52
7.3.2	Register table.....	53
7.3.3	I2C Slave mode	54
7.3.3.1	DMA mode.....	54
7.3.3.2	Mapping mode	55
7.3.4	I2C Master mode	55
7.3.4.1	I2C Master Write transfer.....	56
7.3.4.2	I2C Master Read transfer.....	56
7.3.5	I2C and SPI Usage	56
7.4	SPI	57
7.4.1	Register table	57
7.4.2	SPI Master mode	58
7.4.3	SPI Slave mode	59
7.4.4	I2C and SPI Usage	59
7.5	UART	60
8	PWM.....	63
8.1	Register table.....	63
8.2	Enable PWM	66
8.3	Set PWM clock.....	67
8.4	PWM waveform, polarity and output inversion	67
8.4.1	Waveform of signal frame.....	67
8.4.2	Invert PWM output.....	67

8.4.3	Polarity for signal frame	67
8.5	PWM mode	68
8.5.1	Select PWM mode	68
8.5.2	Continuous mode	68
8.5.2.1	Set PWM clock mode	69
8.5.3	Counting mode	69
8.5.4	IR mode	70
8.5.5	IR FIFO mode	70
8.5.6	IR DMA FIFO mode	72
8.6	PWM interrupt	75
9	Quadrature Decoder	77
9.1	Input pin selection	77
9.2	Common mode and double accuracy mode	77
9.3	Read real time counting value	79
9.4	QDEC reset	80
9.5	Other configuration	80
9.6	Timing sequence	81
9.7	Register table	82
10	SAR ADC	83
10.1	Power on/down	83
10.2	ADC clock	83
10.3	ADC control in auto mode	83
10.3.1	Set max state and enable channel	83
10.3.2	“Set” state	84
10.3.3	“Capture” state	85
10.3.4	Usage cases	86
10.3.4.1	Case 1: 1-channel sampling for Misc	86
10.3.4.2	Case 2: RSSI capture	86
10.3.4.3	Case 3 with detailed register setting	87
10.4	Register table	88
11	PGA	90
11.1	Power on/down	91
11.2	Select input channel	91
11.3	Adjust gain	91

11.4	Enable/Disable PGA output	91
11.5	Load digital register 0x3c.....	91
11.6	Register table.....	92
12	EEPROM.....	93
12.1	Communication protocol.....	93
12.2	EEPROM operation	95
12.2.1	Write operations	95
12.2.2	Read operations.....	96
13	AES.....	99
13.1	RISC mode.....	99
13.2	AES-CCM	99
13.3	Register table	100
14	Key Electrical Specifications	101
14.1	Absolute maximum ratings.....	101
14.2	Recommended operating condition.....	101
14.3	Electrical characteristics	102
14.4	General characteristics	102
14.5	Inputs/Outputs characteristics	102
14.6	Pull-up/Pull-down resistor	103
14.7	SPI characteristics	104
14.8	I2C characteristics.....	105
14.9	RF performance	106
14.10	Crystal characteristics.....	108
14.11	RC oscillator characteristics.....	108
14.12	ADC characteristics	108
15	Application	109
15.1	Application example for TLSR8367EP16.....	109
15.1.1	Schematic	109
15.1.2	BOM (Bill of Material).....	110

1 Overview

The RoHS-compliant TLSR8367 is dedicated to 2.4GHz RF System-On-Chip solution, such as wireless keyboard, wireless mouse, non-audio remote control applications, and etc.

1.1 Block diagram

The TLSR8367 integrates a power-balanced 32-bit proprietary MCU, a high-performance 2.4GHz Radio, 8kB SRAM, 16kB OTP, a general-purpose ADC, a quadrature decoder (QDEC), 5-channel PWM, flexible I/O interfaces and other peripheral blocks required for 2.4GHz RF System-On-Chip solution. Few external components are needed to satisfy customers' ultra-low cost requirements.

The system's block diagram is as shown in Figure 1-1:

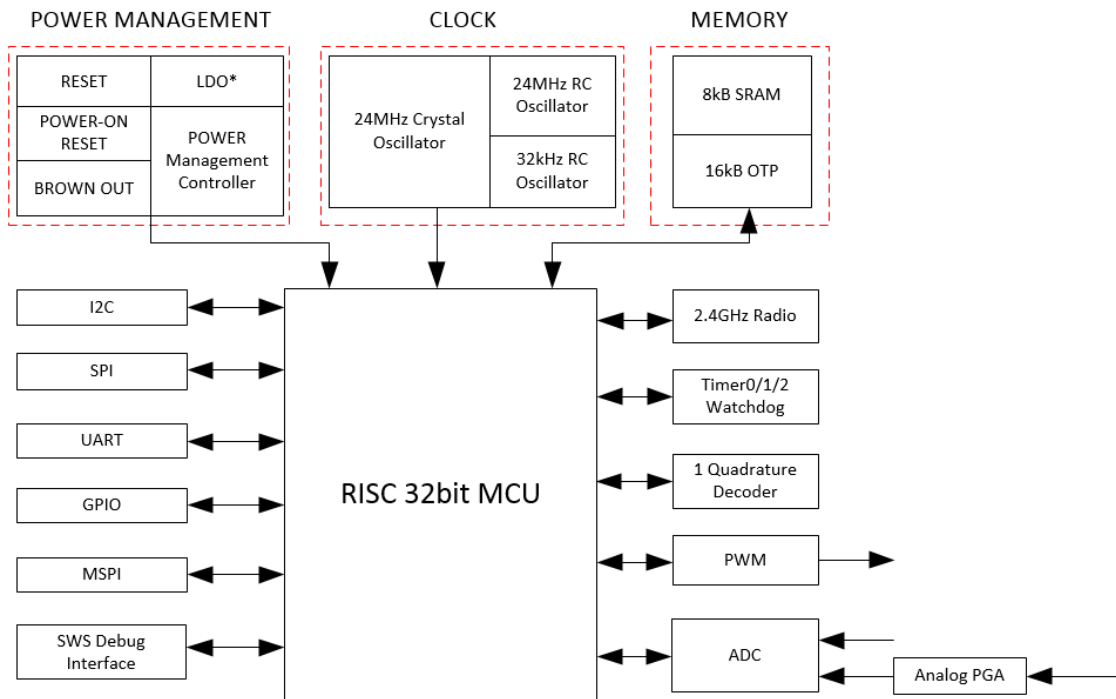

Figure 1- 1 Block diagram of the system

***Note:** The internal LDO regulators serve to supply power for 1.8V digital core and analog modules in Active/Idle/Suspend mode.

1.2 Key features

1.2.1 General features

General features are as follows:

- 1) 32-bit proprietary microcontroller
 - ✧ Better power-balanced performance than ARM M0

- ✧ Instruction cache controller with 2kB cache RAM memory
- ✧ Maximum running speed up to 48MHz
- 2) Memory architecture
 - ✧ 16kB OTP
 - ✧ 8kB SRAM
- 3) Supports 2.4GHz proprietary protocols
- 4) RTC and other timers
 - ✧ Clock source of 24MHz/32kHz RC oscillator, 24MHz crystal oscillator
 - ✧ Three general 32-bit timers, with four selectable modes in active mode
 - ✧ Watchdog timer
 - ✧ A low-frequency 32kHz timer available in low power mode
- 5) Digital and analog interfaces
 - ✧ Up to 31/15/9 GPIOs depending on package option
 - ✧ Configurable pull-up or pull-down resistors
 - ✧ I2C Master/Slave
 - ✧ SPI Master/Slave
 - ✧ Memory SPI
 - ✧ UART interface with hardware flow control
 - ✧ SWS (Single Wire Slave) interface for debugging
 - ✧ One quadrature decoder (QDEC)
 - ✧ Up to 5-channel PWM output
 - ✧ IR transmitter with DMA support
 - ✧ Up to 10-channel (only GPIO input) ADC with 10.5 ENOB
 - ✧ 4-channel differential PGA.
- 6) Hardware AES and random number generator
- 7) Firmware encryption: support software signature based on OTP
- 8) Operating temperature range: -40°C~+85°C
- 9) Package:
 - ✧ 16-pin SOP16L_9.9x6mm, TLSR8367EP16

1.2.2 RF Features

RF features include:

- 1) 2.4GHz RF transceiver in worldwide 2.4GHz ISM band
- 2) 2.4GHz proprietary 2Mbps/1Mbps/500kbps/250kbps mode with Adaptive Frequency Hopping support
- 3) Rx Sensitivity: -90dBm @ 2.4GHz 1Mbps mode, -86.5dBm @ 2.4GHz 2Mbps mode

- 4) Tx Output power: +7dBm
- 5) 50 Ω matched single-pin antenna input
- 6) RSSI monitoring with +/-4dB accuracy

1.2.3 Features of power management module

Features of power management module include:

- 1) Power supply of 1.9V~4.3V (QFN package) / 1.9V~3.6V (SOP16 package)
- 2) Battery monitor for low battery voltage detection
- 3) Brownout detection/shutoff and Power-On-Reset
- 4) Multiple-power-state to optimize power consumption
- 5) Low power consumption
 - Transmitter mode current: 14.5mA @ 0dBm power, 25mA @ 8dBm power
 - Receiver mode current: 13.6mA
 - Suspend mode current:
 - ◇ IO wakeup: 6.8uA
 - ◇ 32kHz RC wakeup: 8uA
 - Deep sleep mode current:
 - ◇ internal 32kHz RC OSC off: 1.9uA
 - ◇ internal 32kHz RC OSC on: 3uA

1.3 Typical application

The TLSR8367 can be applied to 2.4GHz RF System-On-Chip solutions.

Its typical applications include, but are not limited to:

- Wireless keyboard
- Wireless mouse
- Non-audio remote control

1.4 Ordering information

Table 1- 1TLSR8367 ordering information

Product Series	Package Type	Temperature Range	Product Part No.	Packing Method	Minimum Order Quantity
TLSR8367	16-pin SOP16L_ 9.9x6mm	-40°C ~ +85°C	TLSR8367EP16	Tube	5000
TLSR8367E02	16-pin SOP16L_ 9.9x6mm	-40°C ~ +85°C	TLSR8367E02EP16	Tube	5000

*Note: Packing method “TR” means tape and reel.

1.5 Package

Package dimension for the TLSR8367EP16/TLSR8367E02EP16 is shown as below.

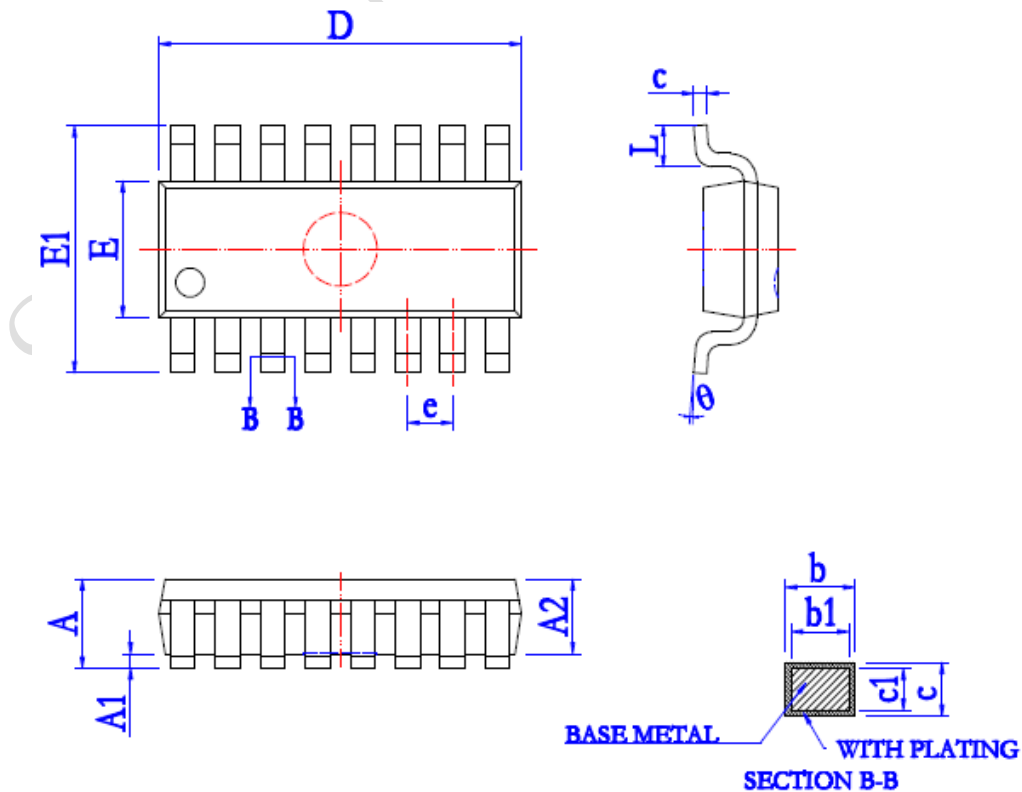

SYMBOL	MILIMETER	
	MIN	MAX
A	1.350	1.750
A1	0.100	0.250
A2	1.350	1.550
b	0.330	0.510
b1	0.320	0.500
c	0.170	0.250
c1	0.160	0.240
D	9.800	10.200
E	3.800	4.000
E1	5.800	6.200
e	1.270BSC	
L	0.400	0.800
θ	0°	8°
L/F Carrier Dimension (mm)	134*91	

Figure 1-2 Package dimension for TLSR8367EP16 (Unit: mm)

1.6 Pin layout

1.6.1 Pin layout for TLSR8367EP16

The figure below shows pin assignment for the TLSR8367EP16.

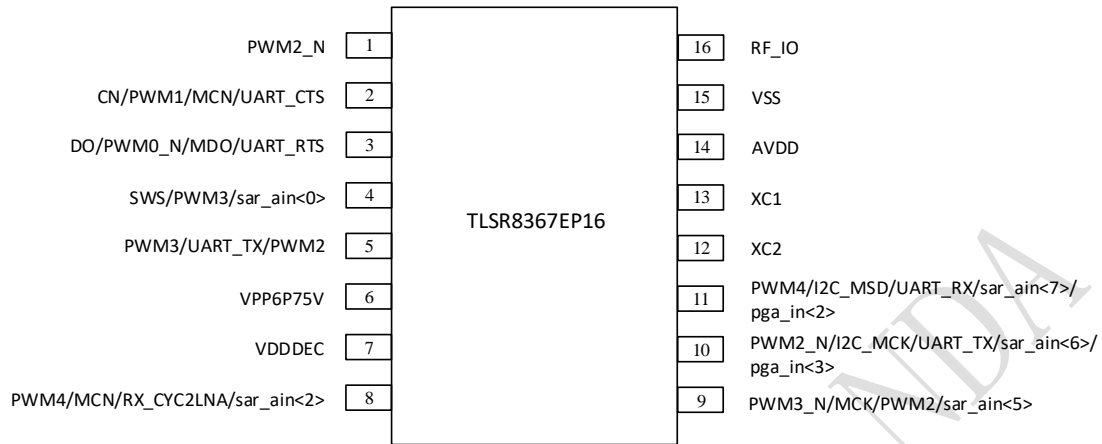

Figure 1- 3 Pin assignment for TLSR8367EP16

Functions of 16 pins for the TLSR8367EP16 is described in the table below:

Table 1- 2 Pin functions for TLSR8367EP16

SOP16L_10X6			
No.	Pin Name	Pin Type	Description
1	PWM2_N / PC[1]	Digital I/O	PWM2_N output / GPIO PC[1]
2	CN / PWM1 / MCN / UART_CTS / PC[2]	Digital I/O	SPI Chip Select / PWM1 output / SPI Master chip select (active low) / UART_CTS / GPIO PC[2]
3	DO / PWM0_N / MDO / UART_RTS / PC[3]	Digital I/O	SPI data output / PWM0_N output / SPI Master data output / UART_RTS / GPIO PC[3]
4	SWS / PWM3 / sar_ain<0> / PC[7]	Digital I/O	Single wire slave / PWM3 output / SAR ADC input / GPIO PC[7]
5	PWM3 / UART_TX / PWM2 / PD[2]	Digital I/O	PWM3 output / UART_TX / PWM2 output / GPIO PD[2]
6	VPP6P75V	PWR	for OTP program 6.75V power supply
7	VDDDEC	PWR	Digital LDO output
8	PWM4 / MCN / RX_CYC2LNA / sar_ain<2> / PB[0]	Digital I/O	PWM4 output / SPI Master chip select (active low) / Control external LNA / SAR ADC input / GPIO PB[0]
9	PWM3_N / MCK / PWM2 / sar_ain<5> / PB[3]	Digital I/O	PWM3 inverting output / SPI Master clock / PWM2 output / SAR ADC input

SOP16L_10X6			
No.	Pin Name	Pin Type	Description
			/ GPIO PB[3]
10	PWM2_N / I2C_MCK / UART_TX / sar_ain<6> / pga_in<3> / PB[4]	Digital I/O	PWM2 inverting output / I2C Master clock / UART_TX / SAR ADC input / PGA input / GPIO PB[4]
11	PWM4 / I2C_MSD / UART_RX / sar_ain<7> / pga_in<2> / PB[5]	Digital I/O	PWM4 output / I2C Master serial data / UART_RX / SAR ADC input / PGA input / GPIO PB[5]
12	XC2	Analog I/O	24MHz crystal input+
13	XC1	Analog I/O	24MHz crystal input-
14	AVDD	PWR	3.3V supply
15	VSS	GND	ground for the whole chip
16	RF_IO	Analog I/O	RF signal input/output (antenna)

1.6.2 Notes

- 1) All digital IOs including PA[0] ~ PD[3] can be used as GPIOs and have configurable pull-up/pull-down resistor.
- 2) I2C and SPI Master/Slave pins can be configured independently.
 - ✧ Pins marked with I2C_MCK and I2C_MSD can be configured as I2C Master clock and serial data.
 - ✧ Pins marked with I2C_CK and I2C_SD can be configured as I2C Slave clock and serial data.
 - ✧ Pins marked with MCN, MDO, MDI and MCK can be configured as SPI Master chip select (active low), data output, data input and clock.
 - ✧ Pins marked with CN, DO, DI and CK can be configured as SPI Slave chip select (active low), data output, data input and clock.
- 3) RX_CYC2LNA & TX_CYC2PA: control enabling external PA/LNA. Please refer to **section 3.1** Block diagram.
- 4) UART with hardware flow control: UART_TX, UART_RX, UART_CTS, UART_RTS.
- 5) ADC input: PC[7], PA[7], PB[0], PB[1], PB[3], PB[4], PB[5]. Please refer to **section 10 SAR ADC**.
- 6) Analog PGA input: PB[4], PB[5]. Please refer to **section 11 PGA**.
- 7) Pin drive strength: PA[0] ~ PD[3] support drive strength up to 8mA (8mA when “DS”=1, 4mA when “DS”=0). Please refer to **section 7.1.1 Basic configuration** for the corresponding “DS” register address and the default setting.

2 Memory and MCU

2.1 Memory

The TLSR8367 embeds 8kB SRAM and 16kB OTP.

2.1.1 SRAM/Register

SRAM/Register memory map is shown as follows:

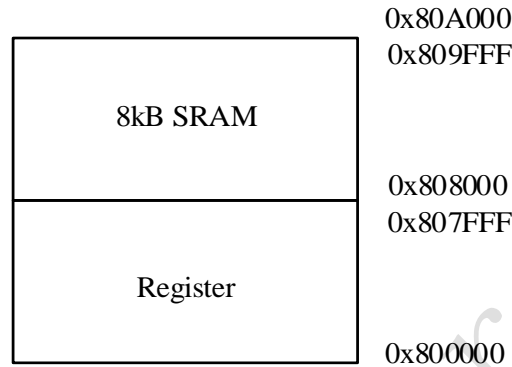

Figure 2- 1 Physical memory map

Register address: 0x800000 ~ 0x807FFF;

8kB SRAM address: 0x808000 ~ 0x809FFF.

Both register and 8kB SRAM address can be accessed (read or write) via debugging interface (SPI/I2C, SWS interface).

2.1.2 OTP

OTP address mapping is configurable.

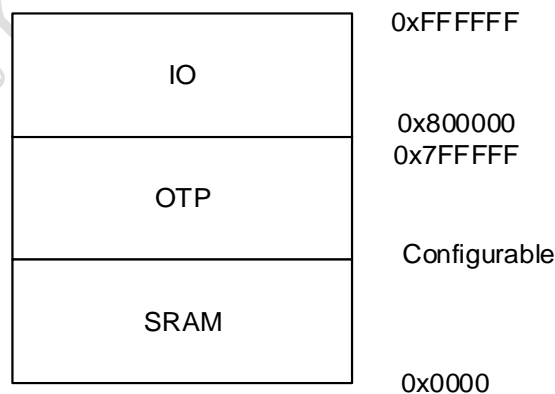

Figure 2- 2 MCU memory map

2.2 Firmware encryption

The TLSR8367 supports Bootloader-based firmware encryption/decryption.

The firmware can be encrypted using a customer-provided security key. The customer security key is written into a specified location within the internal OTP (i.e. the last 4-bytes of the OTP), and becomes unreadable. Any attempt to read the key will only result in either all 1's or all 0's.

The encrypted firmware can be generated based on the plaintext firmware and the customer security key. The customer can burn the security key into the obscured memory area and also the encrypted firmware into the OTP.

The firmware is readable by all, but appears as garbled binaries to 3rd party.

2.3 MCU

The TLSR8367 integrates a powerful 32-bit MCU developed by Telink. The digital core is based on 32-bit RISC, and the length of instructions is 16 bits; four hardware breakpoints are supported.

2.4 Working modes

The TLSR8367 has four working modes: Active, Idle, Suspend and Deep Sleep. This section mainly gives the description of every working mode and mode transition.

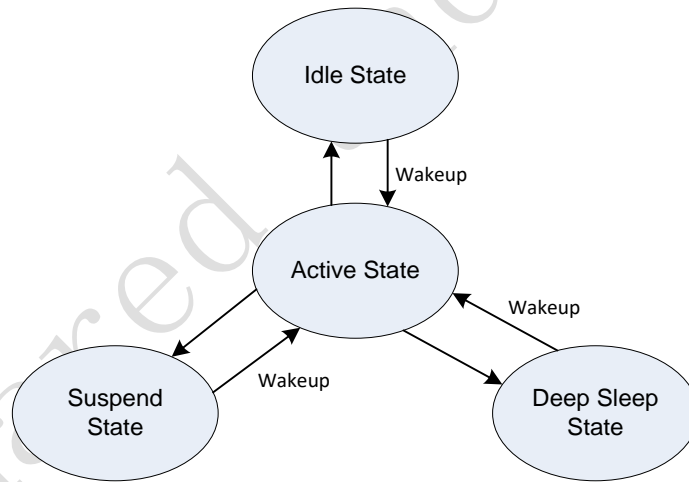

Figure 2-3 Transition chart of working modes

2.4.1 Active mode

In active mode, the MCU block is at working state, and the TLSR8367 can transmit or receive data via its embedded RF transceiver. The RF transceiver can also be powered down if no data transfer is needed.

2.4.2 Idle mode

In Idle mode, the MCU block stalls, and the RF transceiver can be at working state or be

powered down. The time needed for the transition from Idle mode to Active mode is negligible.

2.4.3 Power-saving mode

For the TLSR8367, there are two kinds of power-saving modes: suspend mode and deep sleep mode. The two modes have similar transition sequences but different register settings. For 1.8V digital core, it's still provided with the working power by 1.8V LDO in suspend mode; while in deep sleep mode, the 1.8V LDO will be turned off, and the digital core is powered down.

In suspend mode, the RF transceiver is powered down, and the clock of the MCU block is stopped.

While in deep sleep mode, both the RF transceiver and the MCU block are powered down with only power management block being active.

Deep sleep mode includes two sub-modes, including deep sleep with SRAM retention and deep sleep without SRAM retention.

Table 2- 1 Deep sleep sub modes

Deep Sleep Sub-Mode Characteristic	Deep sleep with SRAM retention	Deep sleep without SRAM retention
Wakeup time to Active mode	Shorter than deep sleep without retention, almost same as Suspend	1ms
8kB retention SRAM (with retention in deep sleep)	full	off

***Note:**

- 1) "full": Full speed. In Active, Idle and Suspend mode, the 8kB retention SRAM is powered on and work normally (can be accessed); in Deep sleep with SRAM retention, the retention SRAM is powered on, however, the contents of the retention SRAMs can be retained and cannot be accessed.
- 2) "off": The retention SRAM is powered down in Deep sleep without SRAM retention.

T_{SP2A} : the transition time needed for the TLSR8367 to enter the active mode from suspend mode.

T_{DS2A} : the transition time needed from deep sleep mode to active mode.

For the tested values of the " T_{SP2A} " and " T_{DS2A} ", please refer to **section 14.4 General characteristics**.

Table 2- 2 Retention analog registers in deep sleep

Address	R/W	Description	Default value
afe_0x34	R/W	buffer, watchdog reset/software reset clean	0x00
afe_0x35	R/W	buffer, watchdog reset/software reset clean	0x00
afe_0x36	R/W	buffer, watchdog reset/software reset clean	0x00
afe_0x37	R/W	buffer, watchdog reset/software reset clean	0x00
afe_0x38	R/W	buffer, watchdog reset/software reset clean	0x00
afe_0x39	R/W	buffer, watchdog reset/software reset clean	0xff
afe_0x3a	R/W	buffer, only power on reset clean	0x00
afe_0x3b	R/W	buffer, only power on reset clean	0x00
afe_0x3c	R/W	buffer, only power on reset clean	0x00
afe_0x3d	R/W	buffer, only power on reset clean	0x00
afe_0x3e	R/W	buffer, only power on reset clean	0x00
afe_0x3f	R/W	buffer, only power on reset clean	0x7f

Analog registers (afe_0x34 ~ afe_0x3f) as shown above are retained in deep sleep mode and can be used to store program state information across deep sleep cycles.

- ✧ Analog registers afe_0x3a~ afe_0x3f are non-volatile even when chip enters deep sleep or chip is reset by watchdog or software, i.e. the contents of these registers won't be changed by deep sleep or watchdog reset or chip software reset.
- ✧ Analog registers afe_0x34~ afe_0x39 are non-volatile in deep sleep, but will be cleared by watchdog reset or chip software reset.
- ✧ After POR (Power-On-Reset), all registers will be cleared to their default values, including these analog registers.

User can set flag in these analog registers correspondingly, so as to check the booting source by reading the flag.

For chip software reset, please refer to **section 2.5 Reset**.

2.5 Reset

The chip supports three types of reset methods, including POR (Power-On-Reset), watchdog reset and software reset.

- 1) POR: After power on, the whole chip will be reset, and all registers will be cleared to their default values.
- 2) Watchdog reset: A programmable watchdog is supported to monitor the system. If watchdog reset is triggered, registers except for retention analog registers `afe_0x3a~afe_0x3f` will be cleared.
- 3) Software reset: It is also feasible to carry out software reset for the whole chip or some modules.
 - ✧ Setting address `0x6f[5]` to `1b'1` is to reset the whole chip. Similar to watchdog reset (see **section 2.4.3 Power-saving mode**), retention analog registers `afe_0x3a~afe_0x3f` are non-volatile, while other registers including `afe_0x34~afe_0x39` will be cleared by chip software reset.
 - ✧ Addresses `0x60~0x62` serve to reset individual modules: if some bit is set to logic "1", the corresponding module is reset.

Table 2- 3 Register configuration for software reset

Address	Mnemonic	Type	Description	Reset Value
0x60	RST0	R/W	Reset control, 1 for reset, 0 for clear [0]: SPI [1]: I2C [2]: n/a [3]: n/a [4]: MCU [5]: n/a [6]: AIF [7]: ZB	0xc0
0x61	RST1	R/W	[0]: system_timer [1]: algm [2]: dma [3]: rs232 [4]: pwm [5]: aes [6]: n/a [7]: swires	0x3f
0x62	RST2	R/W	[0]: n/a [1]: n/a [2]: n/a [3]: adc [4]: mcic [5]: soft reset to reset mcic enable	0x88

Address	Mnemonic	Type	Description	Reset Value
			[6]: rsvd (mspi) [7]: alg	
0x6f	PWDNEN	W	[0]: suspend enable [5]: rst all (act as watchdog reset) [6]: rsvd (mcu low power mode) [7]: stall mcu trig If bit[0] set 1, then system will go to suspend. Or only stall mcu.	0x00

2.6 Power Management

The multiple-stage Power Management (PM) module is flexible to control power state of the whole chip or individual functional blocks such as MCU, RF Transceiver, and peripherals.

2.6.1 Digital LDO

The chip embeds LDO regulators to generate 1.8V regulated voltage. The internal LDO regulators serve to supply power for 1.8V digital core and analog modules in Active/Idle/Suspend mode.

While in deep sleep mode, the embedded 1.8V LDO regulators will be turned off.

2.6.2 VBUS LDO

The embedded VBUS LDO generates 3.0V voltage to supply power for the whole chip. The VBUS LDO supports two working modes, including LDO mode and Bypass mode.

- ✧ When the input voltage VBAT is 3.3V~4.3V, the VBUS LDO works in LDO mode.
- ✧ When the input voltage VBAT is lower than 3.3V, the VBUS LDO works in Bypass mode, and its output voltage is the same as VBAT input voltage.

2.6.3 Power-On-Reset (POR) and Brown-out detect

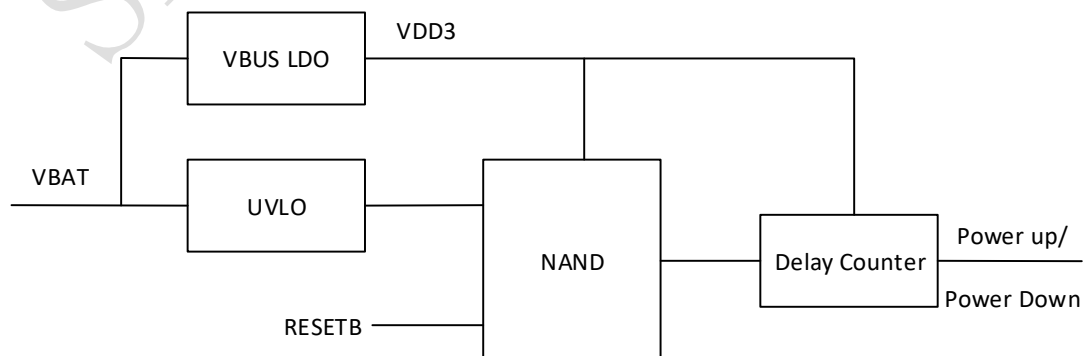

Figure 2- 4 Block diagram for power up/down

The whole chip power up and down is controlled by the UVLO (Ultra-low Voltage Lockout) module and the external RESETB pin via the logic shown in the above diagram. UVLO takes the external power supply as input and releases the lock only when the power supply voltage is higher than a preset threshold. The RESETB pin has an internal pull-up resistor; an external Cap can be connected on the RESETB pin to control the POR delay.

After both UVLO and RESETB release, there is further configurable **delay** before the system reset signal (“Syrst”) is released. This delay is adjusted by analog register afe_0x20. Since the content of afe_0x20 is reset to default only after power cycle, watchdog reset, or software reset, the delay change using afe_0x20 is only applicable when the chip has not gone through these reset conditions. For example, after deep sleep wakeup, the setting in afe_0x20 will take effect.

Table 2- 4 Analog register to control delay counter

Address	Description	Default
afe_0x20	r_dly: [6:0]: delay, 32kHz decrease counter. Default delay 1ms. [7] rsvd	0xe0

***Note:** The register afe_0x20 will be reset to default after power cycle (POR), watchdog reset, or software reset.

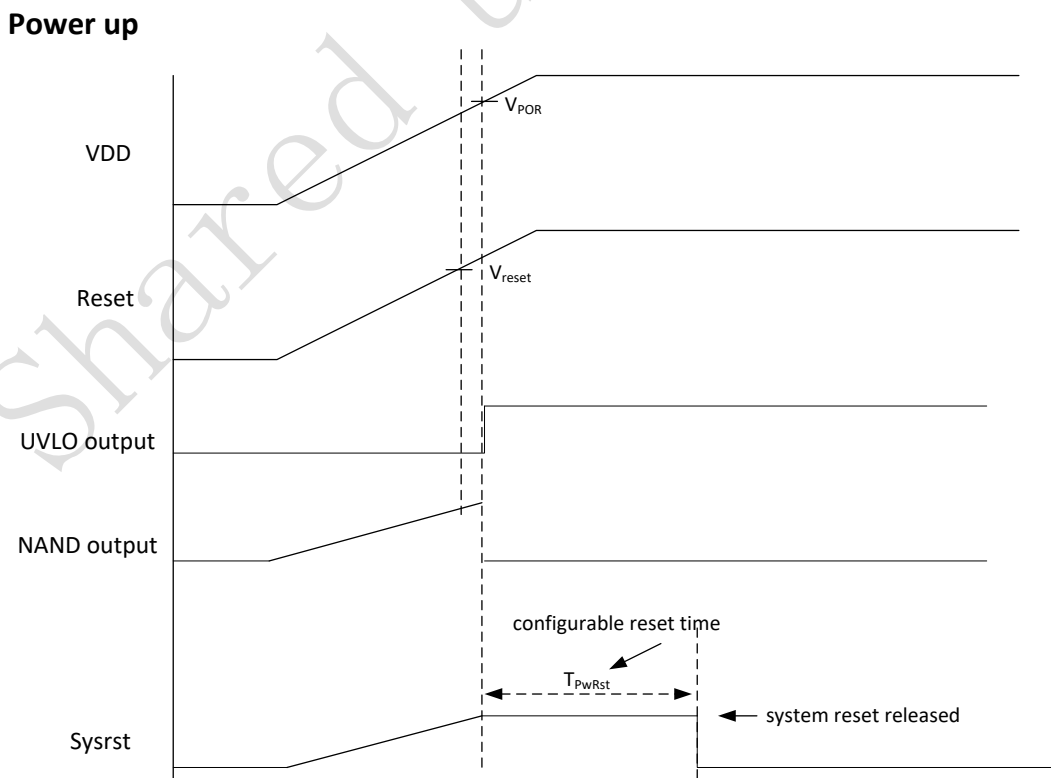

Figure 2- 5 Power-up sequence

Power down

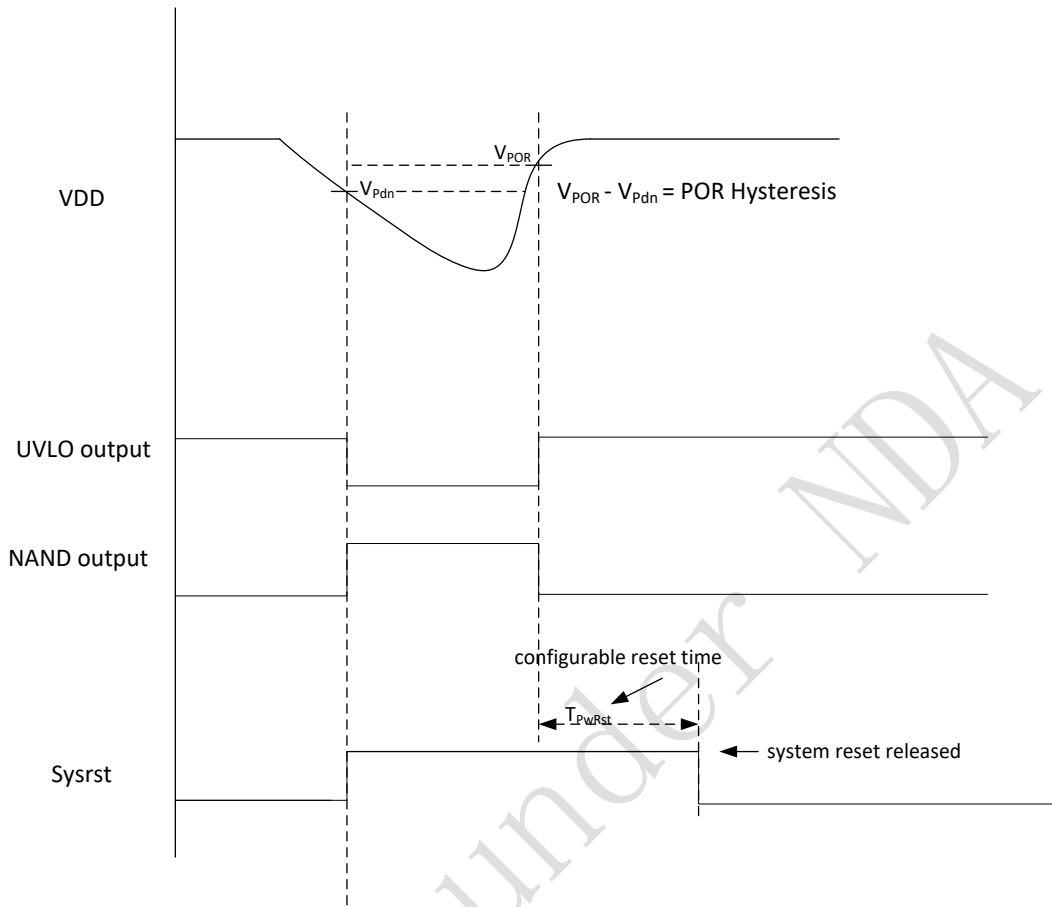

Figure 2- 6 Power-down sequence

The power up and power down sequence is shown in Table 14- 4, with the following parameters:

- ✧ V_{POR} : VDD voltage when V_{UVLO} turns to high level
- ✧ V_{Pdn} : VDD voltage when V_{UVLO} turns to low level
- ✧ T_{PWRst} : Delay counter value (Configurable via analog register afe_0x20)

2.6.4 Working mode switch

The chip can switch to idle mode to stall the MCU.

To minimize power consumption, the chip can switch to power saving mode (suspend or deep sleep) correspondingly. In this case, the low-power 32kHz RC oscillator can still be running, and the low frequency wakeup timer LTIMER can be programmed to stay alive. The device can be activated to working state via external pin trigger or internal wakeup timer.

User can directly invoke corresponding library function to switch working mode of the chip.

If certain module doesn't need to work, user can power down this module in order to save power.

Table 2- 5 Analog registers for module power up/down control

Address	Local name	Default Value	Description
afe_0x05<0>	32K_rc_pd	0	Power down 32kHz RC oscillator 1: Power down 0: Power up
afe_0x05<2>	24M_rc_pd	0	Power down of 24MHz RC oscillator 1: Power down 0: Power up
afe_0x05<3>	xtal_LDO_pd	0	Power down of 24MHz crystal oscillator 1: Power down 0: Power up
afe_0x05<4>	ldo_ana_pd	0	Power down of analog LDO 1: Power down 0: Power up
afe_0x06<1>	rx_lnaLDO_pd	1	Power down LNA LDO in RF transceiver 1: Power down 0: Power up
afe_0x06<2>	rx_anaLDO_pd	1	Power down analog LDO in RF transceiver 1: Power down 0: Power up
afe_0x06<3>	rx_rfLDO_pd	1	Power down RF LDO in RF transceiver 1: Power down 0: Power up
afe_0x06<6>	pll_vco_ldo_pd	1	Power down VCO LDO 1: Power down 0: Power up

2.7 Wakeup sources

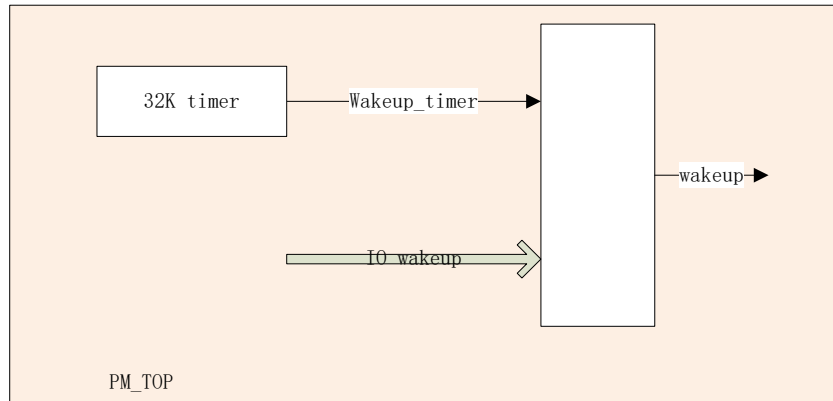

Figure 2- 7 Wakeup sources

2.7.1 Wakeup source – 32kHz timer

This wakeup source is able to wake up the system from suspend mode or deep sleep mode. Address afe_0x26 bit[6] is the enabling bit for wakeup source from 32kHz timer.

2.7.2 Wakeup source – IO

This wakeup source is able to wake up the system from suspend mode or deep sleep mode. And IO wakeup supports high level or low level wakeup which is configurable via wakeup polarity control registers. Total wakeup pin can be up to 11.

Address afe_0x26[4] should be set as 1b'1 to enable IO wakeup source.

Enabling control registers: PA[7:5] enabling control register is afe_0x27[7:5], PB[7:0] enabling control register is afe_0x28[7:0].

Polarity control registers: PA[7:5] polarity control register is afe_0x21[7:5], PB[7:0] polarity control register is afe_0x22[7:0].

The corresponding driver is available so that user can directly invoke it to use IO wakeup source.

2.7.3 Register table

Table 2- 6 Analog registers for Wakeup

Address	R/W	Description	Default Value
afe_0x21	R/W	pa_polarity: [7:5]: select polarity for PA[7]~PA[5] IO (pad) wakeup 0: high level, 1: low level	0x00
afe_0x22	R/W	pb_polarity: [7:0]: select polarity for PB[7]~PB[0] IO (pad) wakeup 0: high level, 1: low level	0x00
afe_0x26[3]	R/W	Enable/Mask filter for IO (Pad) wakeup 1: Select 16us filter to filter out jitter on IO PAD input.	0x00

Address	R/W	Description	Default Value
		0: IO Pad combinational logic output (disable filter)	
afe_0x26[4]	R/W	1: Enable IO (pad) wakeup	
afe_0x26[5]	R/W	Rsvd (Enable digital core wakeup)	
afe_0x26[6]	R/W	1: Enable 32kHz timer wakeup	
afe_0x27	R/W	pad_wkup_pa_en: [7:5]: enable/disable PA[7]~PA[5] IO (pad) wakeup 1: enable; 0: disable	0x00
afe_0x28	R/W	pad_wkup_pb_en: [7:0]: enable/disable PB[7]~PB[0] IO (pad) wakeup 1: enable; 0: disable	0x00
afe_0x44	W1C	State flag bits [1]: pm_irq, i.e. 32kHz timer wakeup status [2]: rsvd (digital core wakeup status) [3] wkup_pad, i.e. IO (pad) wakeup status. Write 1 to clean. e.g. If bit[3] is 1, it indicates the system is waked up by IO (pad) source.	0x00

Table 2- 7 Digital register for Wakeup

Address	Mnemonic	Type	Description	Reset Value
0x6e	WAKEUPEN	R/W	Wakeup enable [0]: rsvd (enable wakeup from I2C host) [1]: rsvd (enable wakeup from SPI host) [2]: rsvd [3]: enable wakeup from gpio [4]: rsvd (enable wakeup from QDEC synchronous interface) System resume control [7]: sleep wakeup reset system enable	1f

3 2.4G RF Transceiver

3.1 Block diagram

The TLSR8367 integrates an advanced 2.4GHz RF transceiver. The RF transceiver works in the worldwide 2.4GHz ISM (Industrial Scientific Medical) band and contains an integrated Balun with a single-ended RF Tx/Rx port pin. No matching components are needed.

The transceiver consists of a fully integrated frequency synthesizer, a power amplifier, a modulator and a receiver. The transceiver can be configured to work in 2.4GHz proprietary 2Mbps/1Mbps/500kbps/250kbps mode.

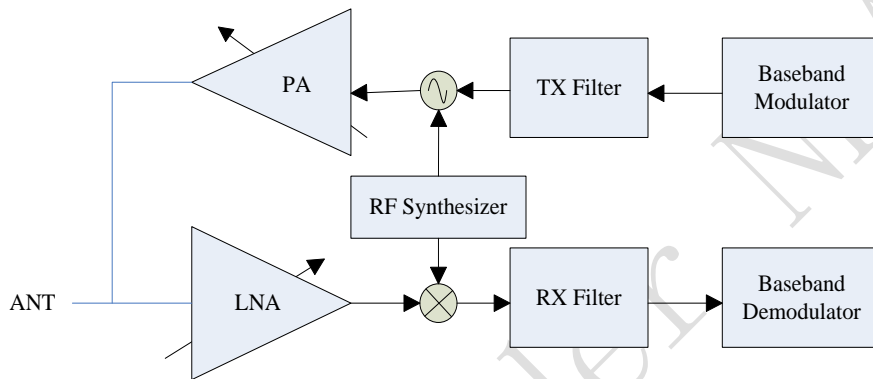

Figure 3- 1 Block diagram of RF transceiver

The internal PA can deliver up to 7dBm output power without the needs for an external RF PA. If higher output power is needed, then an external RF Frontend can be added to boost the output power.

To control **external** RF transceiver with both PA and LNA, first follow the GPIO lookup table (see section 7.1.1.1 GPIO lookup table) to configure the specific two pins as TX_CYC2PA and RX_CYC2LNA function, respectively (Note that GPIO function should be disabled at the same time). After the two pins are configured as TX_CYC2PA and RX_CYC2LNA function, the output function is enabled. Generally the two pins are both high active.

Table 3- 1 External RF transceiver control example

TX_CYC2PA	RX_CYC2LNA	External RF transceiver
L	L	Both LNA and PA OFF
L	H	LNA ON
H	L	PA ON
H	H	N/A

3.2 Function description

3.2.1 Air interface data rate and RF channel frequency

Air interface data rate, the modulated signaling rate for RF transceiver when transmitting and receiving data, is configurable via related register setting: 250kbps, 500kbps, 1Mbps, 2Mbps.

For the TLSR8367, RF transceiver can operate with frequency ranging from 2.400GHz to 2.4835GHz. The RF channel frequency setting determines the center of the channel.

3.3 Baseband

The baseband is disabled by default. The corresponding API is available for user to power on/down the baseband and enable/disable clock, so that the baseband can be turned on/off flexibly.

The baseband contains dedicated hardware logic to perform fast AGC control, access code correlation, CRC checking, data whitening, encryption/decryption and frequency hopping logic.

The baseband supports all features required by 2.4GHz proprietary specification.

3.3.1 Packet format

Packet format in 2.4GHz Proprietary mode is shown as Table 3- 2:

Table 3- 2 Packet format in Proprietary mode

LSB			MSB
Preamble (8 bits)	Address code (configurable 3~5 bytes)	Packet Controller + Payload (1~63 bytes)	CRC (1~2 bytes)

3.3.2 RSSI and frequency offset

The TLSR8367 provides accurate RSSI (Receiver Signal Strength Indicator) and frequency offset indication.

- ✧ 1Byte RSSI can be read upon receiving the data packet.
- ✧ If no data packet is received (e.g. to perform channel energy measurement when no desired signal is present), real-time RSSI can also be read from specific registers which will be updated automatically.
- ✧ RSSI resolution can reach +/-4dB.
- ✧ 2-Byte Frequency offset value can be read upon receiving the data packet. Valid bits of actual frequency offset may be less than 16bits, and different valid bits correspond to different tolerance range.

Telink supplies corresponding drivers for user to read RSSI and frequency offset as needed.

4 Clock

4.1 Clock sources

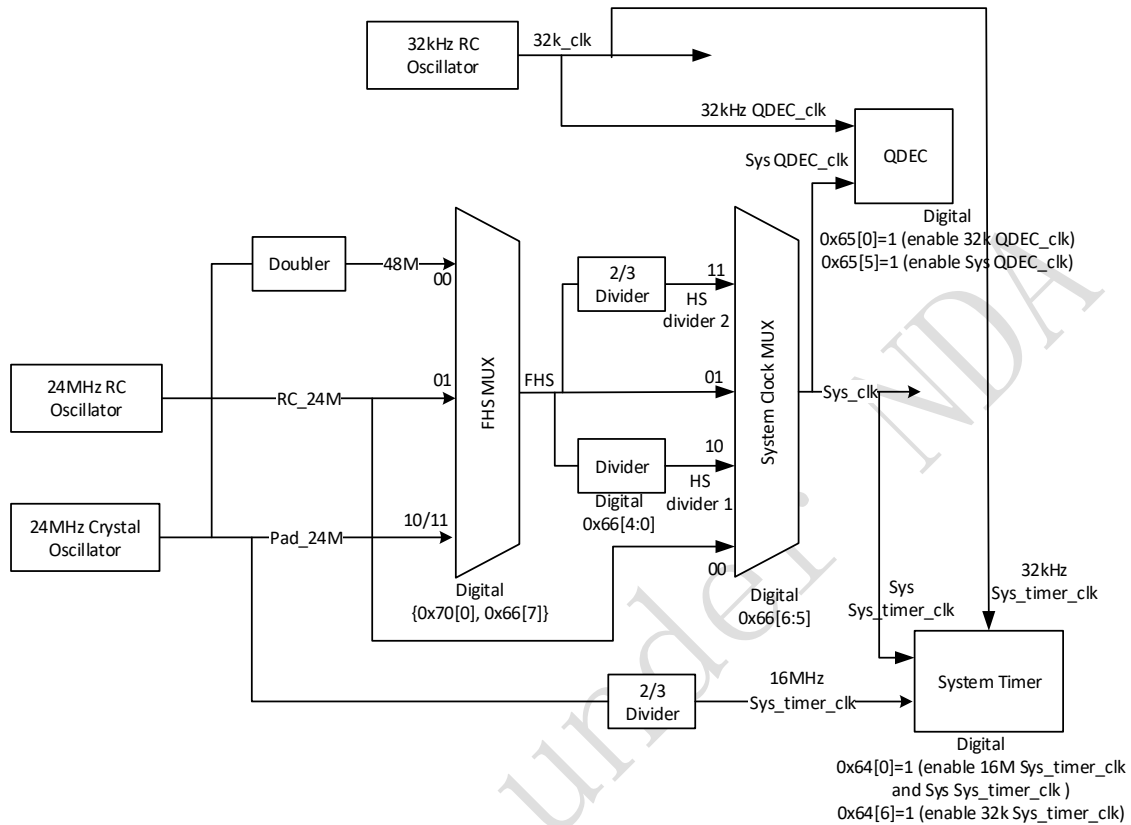

Figure 4- 1 Block diagram of clock

The TLSR8367 clock supports 24MHz external crystal or 24MHz/32kHz embedded RC oscillator.

- ✧ A **RC_24M** clock is available from an embedded 24MHz RC oscillator. It can be directly used as clock source for system, and it's also a selectable source for high speed clock (FHS). When system clock is configured as 24MHz RC (default), the RC_24M clock can be output to PA[7] by configuring the digital registers as below: 0x586=0x7f, 0x5a9=0x40.
- ✧ A **RC_32k** clock is available from an embedded 32kHz RC oscillator. It can provide a 32kHz clock source for 32kHz timer during sleep state as well as System Timer and QDEC module. When 32kHz clock is configured as 32kHz RC (default), the RC_32k clock can be output to PA[1] by configuring the digital registers as below: 0x586=0xfd, 0x5a8=0x08.
- ✧ A **Pad_24M** clock is available from external 24MHz crystal via pin XC1 and XC2. It can provide 16MHz clock source for System Timer via a 2/3 frequency divider. The Pad_24M can be directly used as clock source for high speed clock (FHS), or generate a 48MHz clock source via a frequency doubler for FHS.
- ✧ High speed clock (FHS) can be directly used as clock source for system, or generate HS divider clock 1 or 2 source via a configurable or fixed 2/3 frequency divider for system.

4.2 System clock

There are four selectable clock sources for MCU system clock: **RC_24M** (derived from 24MHz RC oscillator), High speed clock “**FHS**”, **HS divider clock 1** (derived from “FHS” via a configurable frequency divider), **HS divider clock 2** (derived from “FHS” via a fixed 2/3 frequency divider).

The high speed clock (FHS) is selectable via address {0x70[0], 0x66[7]} from the following sources: **48MHz** clock (derived from 24MHz crystal oscillator via a frequency doubler), **RC_24M** (derived from 24MHz RC oscillator), and **Pad_24M** (derived from 24MHz crystal oscillator).

The digital register CLKSEL (address 0x66) serves to set system clock: System clock source is selectable via bit[6:5].

- ✧ If address 0x66[6:5] is set to 2b'00 to select the RC_24M, system clock frequency equals 24MHz.
- ✧ If address 0x66[6:5] is set to 2b'01 to select the FHS clock, system clock frequency equals the FHS frequency (F_{FHS}).
- ✧ If address 0x66[6:5] is set to 2b'10 to select the HS divider clock 1, system clock frequency is adjustable via address 0x66[4:0]. The formula is shown as below:

$$F_{\text{System clock}} = F_{FHS} / (\text{system clock divider value in address } 0x66[4:0]).$$

- ✧ If address 0x66[6:5] is set to 2b'11 to select the HS divider clock 2, system clock frequency equals $F_{FHS} * 2/3$.

4.3 Module clock

Registers CLKEN0~CLKEN2 (address 0x63~0x65) are used to enable or disable clock for various modules. By disable the clocks of unused modules, current consumption could be reduced.

4.3.1 System Timer clock

System Timer simultaneously uses system clock, a 16MHz clock, as well as a 32kHz clock.

- ✧ The 16MHz clock is derived from 24MHz crystal oscillator via a 2/3 frequency divider.
- ✧ The 32kHz clock is **RC_32k**.
- ✧ Digital register 0x64 bit[0] and bit[6] should be enabled to drive the System Timer by the 16MHz clock, system clock, as well as the 32kHz clock.

4.3.2 QDEC clock

QDEC module simultaneously uses system clock as well as a 32kHz clock.

- ✧ The 32kHz clock is **RC_32k**.
- ✧ Digital register 0x65 bit[0] and bit[5] should be enabled to drive the whole QDEC module by the 32kHz clock and system clock.

4.4 Register table

Table 4- 1 Register table related to clock

Address	Mnemonic	R/W	Description	Default
Digital register				
0x63	CLKEN0	R/W	Clock enable control: 1 for enable; 0 for disable [0]: SPI [1]: I2C [2]: HOSTIRQ [3]: n/a [4]: MCU [5]: FPU (Float Point Unit) [6]: AIF [7]: ZB	13
0x64	CLKEN1	R/W	Clock enable control: 1 for enable; 0 for disable [0]: System timer (16M_clk and sys_clk for System timer) [1]: ALGM [2]: DMA [3]: RS232 [4]: PWM [5]: AES [6]: 32k_clk for system timer [7]: Swires	80
0x65	CLKEN2	R/W	Clock enable control: 1 for enable; 0 for disable [0]: 32k_clk for QDEC [1]: 32k_clk for PWM [2:3]: n/a [4]: MCIC [5]: QDEC (sys_clk for QDEC) [6:7]: n/a	10
0x66	CLKSEL	R/W	System clock select [4:0]: system clock divider. If 0x66[6:5] is set as 2b' 10, $F_{\text{Sysclk}} = F_{\text{FHS}} / \text{CLKSEL}[4:0]$. FHS: refer to 0x70 FHS_sel. [6:5]: select system clock source 2'b00: RC_24M from RC oscillator 2'b01: FHS clock (High speed clock) 2'b10: HS divider clock 1 derived from FHS clock via a configurable divider (see 0x66[4:0]) 2'b11: HS divider clock 2 derived from FHS clock via a fixed 2/3 divider {0x70[0], 0x66[7]}: FHS select	06
0x70	FHS_sel	R/W	{0x70[0], 0x66[7]}: FHS select 2'b00: 48MHz clock doubled from 24MHz crystal oscillator 2'b01: RC_24M from RC oscillator 2'b1x: Pad_24M from 24MHz crystal oscillator	00

5 Timers

5.1 Timer0~Timer2

The TLSR8367 supports three general 32-bit timers in active mode, including Timer0~ Timer2. All of the three timers support four modes: Mode 0 (System Clock Mode), Mode 1 (GPIO Trigger Mode), Mode 2 (GPIO Pulse Width Mode) and Mode 3 (Tick Mode), which are selectable via the register TMR_CTRL0 (address 0x620) ~ TMR_CTRL1 (address 0x621).

Timer 2 can also be configured as “watchdog” timer to monitor firmware running.

5.1.1 Register table

Table 5- 1 Register configuration for Timer0~Timer2

Address	Mnemonic	Type	Description	Reset Value
0x72	Wd_status	R/W	[0] watch dog status, write 1 to clear.	00
0x620	TMR_CTRL0	RW	[0]Timer0 enable 1: enable [2:1] Timer0 mode. 0: using sclk, 1: using gpio, 2: count width of gpi, 3: tick [3]Timer1 enable [5:4] Timer1 mode. [6]Timer2 enable [7]Bit of timer2 mode	00
0x621	TMR_CTRL1	RW	[0]Bit of timer2 mode [7:1]Low bits of watch dog capture	00
0x622	TMR_CTRL2	RW	[6:0]High bits of watch dog capture. Watch dog capture is compared with [31:18] of timer2 ticker. [7]watch dog capture enable 1: enable	00
0x623	TMR_STATUS	RW	[0] timer0 status, write 1 to clear [1] timer1 status, write 1 to clear [2] timer2 status, write 1 to clear	00
0x624	TMR_CAPT0_0	RW	Byte 0 of timer0 capture	00
0x625	TMR_CAPT0_1	RW	Byte 1 of timer0 capture	00
0x626	TMR_CAPT0_2	RW	Byte 2 of timer0 capture	00
0x627	TMR_CAPT0_3	RW	Byte 3 of timer0 capture	00
0x628	TMR_CAPT1_0	RW	Byte 0 of timer1 capture	00
0x629	TMR_CAPT1_1	RW	Byte 1 of timer1 capture	00
0x62a	TMR_CAPT1_2	RW	Byte 2 of timer1 capture	00
0x62b	TMR_CAPT1_3	RW	Byte 3 of timer1 capture	00
0x62c	TMR_CAPT2_0	RW	Byte 0 of timer2 capture	00
0x62d	TMR_CAPT2_1	RW	Byte 1 of timer2 capture	00

Address	Mnemonic	Type	Description	Reset Value
0x62e	TMR_CAPT2_2	RW	Byte 2 of timer2 capture	00
0x62f	TMR_CAPT2_3	RW	Byte 3 of timer2 capture	00
0x630	TMR_TICK0_0	RW	Byte 0 of timer0 ticker	00
0x631	TMR_TICK0_1	RW	Byte 1 of timer0 ticker	00
0x632	TMR_TICK0_2	RW	Byte 2 of timer0 ticker	00
0x633	TMR_TICK0_3	RW	Byte 3 of timer0 ticker	00
0x634	TMR_TICK1_0	RW	Byte 0 of timer1 ticker	00
0x635	TMR_TICK1_1	RW	Byte 1 of timer1 ticker	00
0x636	TMR_TICK1_2	RW	Byte 2 of timer1 ticker	00
0x637	TMR_TICK1_3	RW	Byte 3 of timer1 ticker	00
0x638	TMR_TICK2_0	RW	Byte 0 of timer2 ticker	00
0x639	TMR_TICK2_1	RW	Byte 1 of timer2 ticker	00
0x63a	TMR_TICK2_2	RW	Byte 2 of timer2 ticker	00
0x63b	TMR_TICK2_3	RW	Byte 3 of timer2 ticker	00

5.1.2 Mode0 (System Clock Mode)

In Mode 0, system clock is used as clock source.

After Timer is enabled, Timer Tick (i.e. counting value) is increased by 1 on each positive edge of system clock from preset initial Tick value. Generally the initial Tick value is set as 0.

Once current Timer Tick value matches the preset Timer Capture (i.e. timing value), Timer stops counting, Timer status is updated, and an interrupt is generated (if enabled).

Following is an example to show steps of setting Timer0 as Mode 0.

1st: Set initial Tick value of Timer0

Set initial Tick value of Timer0 via registers TMR_TICK0_0~TMR_TICK0_3 (address 0x630~0x633). Address 0x630 is lowest byte and 0x633 is highest byte. It's recommended to clear initial Timer Tick value to 0.

2nd: Set Capture value of Timer0

Set registers TMR_CAPT0_0~TMR_CAPT0_3 (address 0x624~0x627). Address 0x624 is lowest byte and 0x627 is highest byte.

3rd: Set Timer0 as Mode 0 and enable Timer0

Set register TMR_CTRL0 (address 0x620) [2:1] as 2b'00 to select Mode 0; Meanwhile set address 0x620[0] as 1b'1 to enable Timer0. Timer0 starts counting upward, and Tick value is increased by 1 on each positive edge of system clock until it reaches Timer0 Capture value.

5.1.3 Mode1 (GPIO Trigger Mode)

In Mode 1, GPIO is used as clock source. The "m0"/"m1"/"m2" register specifies the GPIO which generates counting signal for Timer0/Timer1/Timer2.

After Timer is enabled, Timer Tick (i.e. counting value) is increased by 1 on each positive/negative (configurable) edge of GPIO from preset initial Tick value. Generally the initial Tick value is set as 0. The “Polarity” register specifies the GPIO edge when Timer Tick counting increases.

Note: Refer to **Section 7.1.2** for corresponding “m0”, “m1”, “m2” and “Polarity” register address.

Once current Timer Tick value matches the preset Timer Capture (i.e. timing value), timer stops counting and an interrupt is generated (if enabled).

Following is an example to show steps of setting Timer1 as Mode 1.

1st: Set initial Tick value of Timer1

Set initial Tick value of Timer1 via registers TMR_TICK1_0~TMR_TICK1_3 (address 0x634~0x637). Address 0x634 is lowest byte and 0x637 is highest byte. It's recommended to clear initial Timer Tick value to 0.

2nd: Set Capture value of Timer1

Set registers TMR_CAPT1_0~TMR_CAPT1_3 (address 0x628~0x62b). Address 0x628 is lowest byte and 0x62b is highest byte.

3rd: Select GPIO source and edge for Timer1

Select certain GPIO to be the clock source via setting “m1” register.

Select positive edge or negative edge of GPIO input to trigger Timer1 Tick increment via setting “Polarity” register.

4th: Set Timer1 as Mode 1 and enable Timer1

Set address 0x620[5:4] as 2b'01 to select Mode 1; Meanwhile set address 0x620[3] as 1b'1 to enable Timer1. Timer1 starts counting upward, and Timer1 Tick value is increased by 1 on each positive/negative (specified during the 3rd step) edge of the specified GPIO input until it reaches Timer1 Capture value.

5.1.4 Mode2 (GPIO Pulse Width Mode)

In Mode 2, system clock is used as the unit to measure the width of GPIO pulse. The “m0”/“m1”/“m2” register specifies the GPIO which generates control signal for Timer0/Timer1/Timer2.

After Timer is enabled, Timer Tick is triggered by a positive/negative (configurable) edge of GPIO pulse. Then Timer Tick (i.e. counting value) is increased by 1 on each positive edge of system clock from preset initial Tick value. Generally the initial Tick value is set as 0. The “Polarity” register specifies the GPIO edge when Timer Tick starts counting.

Note: Refer to **Section 7.1.2** for corresponding “m0”, “m1”, “m2” and “Polarity” register address.

While a negative/positive edge of GPIO pulse is detected, timer stops counting and an interrupt is generated (if enabled). The GPIO pulse width could be calculated in terms of tick count and period of system clock.

Following is an example to show steps of setting Timer2 as Mode 2.

1st: Set initial Timer2 Tick value

Set Initial value of Tick via registers TMR_TICK2_0~TMR_TICK2_3 (address 0x638~0x63b). Address 0x638 is lowest byte and 0x63b is highest byte. It's recommended to clear initial Timer Tick

value to 0.

2nd: Select GPIO source and edge for Timer2

Select certain GPIO source via setting “m2” register.

Select positive edge or negative edge of GPIO input to trigger Timer2 counting start via setting “Polarity” register.

3rd: Set Timer2 as Mode 2 and enable Timer2

Set address 0x620[7:6] to 2b’01 and address 0x621 [0] to 1b’1.

Timer2 Tick is triggered by a positive/negative (specified during the 2nd step) edge of the specified GPIO pulse. Timer2 starts counting upward and Timer2 Tick value is increased by 1 on each positive edge of system clock.

While a negative/positive edge of GPIO pulse is detected, Timer2 tick stops and an interrupt is generated (if enabled).

4th: Read current Timer2 Tick value to calculate GPIO pulse width

Read current Timer2 Tick value from address 0x638~0x63b.

Then GPIO pulse width is calculated as follows:

GPIO pulse width = System clock period * (current Timer2 Tick – initial Timer2 Tick)

For initial Timer2 Tick value is set to the recommended value of 0, then:

GPIO pulse width = System clock period * current Timer2 Tick.

5.1.5 Mode3 (Tick Mode)

In Mode 3, system clock is used as clock source.

After Timer is enabled, Timer Tick starts counting upward, and Timer Tick value is increased by 1 on each positive edge of system clock.

This mode could be used as time indicator. No interrupt will be generated. Timer Tick keeps rolling from 0 to 0xffffffff. When Timer tick overflows, it returns to 0 and starts counting upward again.

Following is an example to show steps of setting Timer0 as Mode 3.

1st: Set initial Tick value of Timer0

Set Initial value of Tick via address 0x630~0x633. Address 0x630 is lowest byte and address 0x633 is highest byte. It’s recommended to clear initial Timer Tick value to 0.

2nd: Set Timer0 as Mode 3 and enable Timer0

Set address 0x620[2:1] as 2b’11 to select Mode 3, meanwhile set address 0x620[0] as 1b’1 to enable Timer0. Timer0 Tick starts to roll.

3rd: Read current Timer0 Tick value

Current Timer0 Tick value can be read from address 0x630~0x633.

5.1.6 Watchdog

Only Timer2 can be used as a watchdog timer, so that it could reset chip from unexpected hang up or malfunction.

Timer2 Tick has 32bits. Watchdog Capture has only 14bits, which consists of TMR_CTRL2 (address 0x622) [6:0] as higher bits and TMR_CTRL1 (address 0x621) [7:1] as lower bits. Chip will be reset when the Timer2 Tick[31:18] matches Watchdog Capture value.

The range of duration that can be set in watchdog is between $T(\text{sysclk}) \cdot 2^{18}$ and $T(\text{sysclk}) \cdot 2^{32}$, and $T(\text{sysclk})$ is the system clock period which is configurable. For example, if system clock is configured to 16MHz, then the upper time limit of watchdog reset is $2^{32}/16\text{MHz} \approx 268\text{s}$.

Following shows steps of setting Timer2 as watchdog timer.

1st: Clear Timer2 Tick value

Clear registers TMR_TICK2_0 ~TMR_TICK2_3 (address 0x638~0x63b). Address 0x638 is lowest byte and 0x63b is highest byte.

2nd: Enable Timer2

Set register TMR_CTRL0 (address 0x620) [6] as 1b'1 to enable Timer2.

3rd: Set 14-bit Watchdog Capture value and enable Watchdog

Set higher 7 bits and lower 7 bits of Watchdog Capture via address 0x622[6:0] and 0x621[7:1]. Meanwhile set address 0x622[7] as 1b'1 to enable Watchdog.

Then Timer2 Tick starts counting upwards from 0.

If bits[31:18] of Timer2 Tick value read from address 0x638~0x63b reaches Watchdog Capture, the chip will be reset, and the status bit in address 0x72[0] will be set as 1b'1 automatically. User can read the watchdog status bit after chip reset to check if the reset source is watchdog, and needs to write 1b'1 to this bit to manually clear the flag.

5.2 32kHz LTIMER

The TLSR8367 also supports a low frequency (32kHz) timer "LTIMER" in suspend mode or deep sleep mode. This 32kHz timer can be used as one kind of wakeup source.

32kHz LTIMER related functions are all handled in the stack.

5.3 System Timer

The TLSR8367 also supports a System Timer. Please refer to section 4.3.1 for System Timer clock.

In suspend mode, both System Timer and Timer0~Timer2 stop counting, and 32kHz Timer starts counting. When the chip restores to active mode, Timer0~Timer2 will continue counting from the number when they stops; In contrast, System Timer will continue counting from an adjusted number which is a sum of the number when it stops and an offset calculated from the counting value of 32kHz Timer during suspend mode.

System timer related functions are all handled in the stack.

Table 5- 2 Register table for System Timer

Address	Mnemonic	R/W	Function	Default Value
0x740	Sys_timer[7:0]	R/W		0x00
0x741	Sys_timer[15:8]	R/W		0x00
0x742	Sys_timer[23:16]	R/W		0x00
0x743	Sys_timer[31:24]	R/W	System timer counter, write to set initial value.	0x00
0x748	32K_cal_latch[7:0]	R	32k calibration count[7:0]	0x00
0x749	32K_cal_latch[15:8]	R	32k calibration count[15:8]	0x00
0x74a	Sys_timer_ctrl	R/W	[7]: enable of system timer [6]: irq_mask for system timer 1: enable, 0: disable [5:4]: calibration mode 2'b00: 4 cycles of 32kHz clock 2'b01: 8 cycles of 32kHz clock 2'b10: 16 cycles of 32kHz clock (Default setting) 2'b11: 32 cycles of 32kHz clock [3]: calibration enable [2]: set to 0 [1]: rsvd [0]: set 32kHz timer 1: write; 0: read	0x21
0x74b	Sys_timer_cmd	WO	[7:6]: rsvd [5]: clear 32k read latch update flag [4]: rsvd [3]: start 32k count write/read [2:0]: rsvd	0x00
0x74b	Sys_timer_status	RO	[7]: rsvd [6]: rd_busy_man_2d [5]: rd_update_man_2d [4]: rsvd [3]: ss_sync [2]: cmd_set_tgl [1:0]: rsvd	0x00
0x74c	sys_timer_32K_set [7:0]	R/W	32k timer write[7:0]	0x00
0x74d	sys_timer_32K_set [15:8]	R/W	32k timer write[15:8]	0x00
0x74e	sys_timer_32K_set [23:16]	R/W	32k timer write[23:16]	0x00
0x74f	sys_timer_32K_set [31:24]	R/W	32k timer write[31:24]	0x00
0x750	sys_timer_32K_read [7:0]	R	32k timer read[7:0]	0x00

Address	Mnemonic	R/W	Function	Default Value
0x751	sys_timer_32K_read [15:8]	R	32k timer read[15:8]	0x00
0x752	sys_timer_32K_read [23:16]	R	32k timer read[23:16]	0x00
0x753	sys_timer_32K_read [31:24]	R	32k timer read[31:24]	0x00

***Note:**

32kHz clock calibration is related to 32k cycle numbers used. More cycles correspond to higher accuracy but more time. Generally 32kHz clock calibration will select 16 cycles of 32kHz clock.

The lower three bits of address 0x740 is invalid, therefore, the resolution should be 0.5us. The 0.5us resolution is only used for system timer read out. 32kHz clock calibration is done using every 16MHz clock cycle, so 32kHz clock accuracy is not affected.

1. Get 32kHz Timer count value

0x74a[0] = 0; //set to 32kHz Timer read mode

0x74a[3] = 1; //enable calibration to provide 16MHz clock count value related to 32kHz cycle (0x74a[5:4])

0x74a[7] = 1; //kick system timer to tick

0x74b[5] = 0; //clear 32kHz read update flag

Wait for 0x74b[5]==1; //wait for the next 32kHz update flag

Read 32kHz Timer value from 0x750

2. Set 32kHz Timer count value

0x74a[0] = 1; //set to 32kHz Timer write mode

Wait for 0x74b[6]==0; //see whether during 32kHz read

Write 32kHz Timer value to 0x74c;

0x74b[3] = 1; //start 32kHz write sync process

Wait for 0x74b[3] from 0 to 1; //wait 32kHz sync indicator from 16MHz to sys domain

Wait for 0x74b[3] from 1 to 0; //wait 32kHz sync indicator done

6 Interrupt System

6.1 Interrupt structure

The interrupting function is applied to manage dynamic program sequencing based on real-time events triggered by timers, pins and etc.

For the TLSR8367, there are 24 interrupt sources in all: 16 types are level-triggered interrupt sources (listed in address 0x640~0x641) and 8 types are edge-triggered interrupt sources (listed in address 0x642).

When CPU receives an interrupt request (IRQ) from some interrupt source, it will determine whether to respond to the IRQ. If CPU decides to respond, it pauses current routine and starts to execute interrupt service subroutine. Program will jump to certain code address and execute IRQ commands. After finishing interrupt service subroutine, CPU returns to the breakpoint and continues to execute main function.

6.2 Register configuration

Table 6- 1 Register table for Interrupt system

Address	Mnemonic	Type	Description	Reset Value
0x640	MASK_0	RW	Byte 0 interrupt mask, level-triggered type {irq_host_cmd, irq_uart, rsvd, irq_dma, rsvd, time2, time1, time0} [7] irq_host_cmd [6] irq_uart [5] rsvd [4] irq_dma [3] rsvd [2] time2 [1] time1 [0] time0	0x00
0x641	MASK_1	RW	Byte 1 interrupt mask, level-triggered type {an_irq, irq_pwm, irq_zb_rt, irq_software, 4'b0} [7] an_irq [6] irq_pwm [5] irq_zb_rt [4] irq_software [3:0] rsvd	0x00
0x642	MASK_2	RW	Byte 2 interrupt mask, edge-triggered type {gpio2risc[2:0], 1'b0, pm_irq, irq_gpio, 2'b0} [7] gpio2risc[2] [6] gpio2risc[1] [5] gpio2risc[0] [4] irq_stimer, used together with address 0x74a[6] [3] pm_irq [2] irq_gpio [1:0] rsvd	0x00

Address	Mnemonic	Type	Description	Reset Value
0x643	IRQMODE	RW	[0] interrupt enable [1] reserved (Multi-Address enable)	0x00
0x644	PRIO_0	RW	Byte 0 of priority 1: High priority; 0: Low priority	0x00
0x645	PRIO_1	RW	Byte 1 of priority	0x00
0x646	PRIO_2	RW	Byte 2 of priority	0x00
0x648	IRQSRC_0	R	Byte 0 of interrupt source	0x00
0x649	IRQSRC_1	R	Byte 1 of interrupt source	0x00
0x64a	IRQSRC_2	R	Byte 2 of interrupt source	0x00

6.2.1 Enable/Mask interrupt sources

Various interrupt sources could be enabled or masked by registers MASK_0~MASK_2 (address 0x640~0x642).

Interrupt sources of level-triggered type:

- ✧ irq_host_cmd (0x640[7]): I2C Slave mapping mode or SPI Slave interrupt
- ✧ irq_uart (0x640[6]): UART interrupt
- ✧ irq_dma (0x640[4]): DMA interrupt
- ✧ time2, time1, timer0 (0x640[2]~0x640[0]): Timer2~Timer0 interrupt
- ✧ an_irq (0x641[7]): pm_irq, gpio2risc[2], gpio2risc[1] or gpio2risc[0] interrupt selectable via digital register 0x26[2:0], not recommended to use.
- ✧ irq_pwm (0x641[6]): PWM interrupt
- ✧ irq_zb_rt (0x641[5]): Baseband interrupt
- ✧ irq_software (0x641[4]): Software interrupt

Interrupt sources of edge-triggered type:

- ✧ gpio2risc[2:0] (0x642[7]~0x642[5]): gpio2risc[2]~gpio2risc[0] interrupt, please refer to section 7.1.2.
- ✧ irq_stimer (0x642[4]): System timer interrupt, should be used together with address 0x74a[6]
- ✧ pm_irq (0x642[3]): 32kHz timer wakeup interrupt
- ✧ irq_gpio (0x642[2]): GPIO interrupt, please refer to section 7.1.2.

6.2.2 Interrupt mode and priority

Interrupt mode is typically-used mode. Register IRQMODE (address 0x643)[0] should be set as 1b'1 to enable interrupt function.

IRQ tasks could be set as High or Low priority via registers PRIO_0~PRIO_2 (address 0x644~0x646). When more than one interrupt sources assert interrupt requests at the same time, CPU will respond depending on respective interrupt priority levels. It's recommended not to modify priority setting.

6.2.3 Interrupt source flag

Three bytes in registers IRQSRC_0~IRQSRC_2 (address 0x648~0x64a) serve to indicate IRQ sources. Once IRQ occurs from certain source, the corresponding IRQ source flag will be set as "1". User could identify IRQ source by reading address 0x648~0x64a.

When handling edge-triggered type interrupt, the corresponding IRQ source flag needs to be cleared via address 0x64a. Take the interrupt source irq_gpio for example: First enable the interrupt source by setting address 0x642 bit[2] as 1b'1; then set address 0x643 bit[0] as 1b'1 to enable the interrupt. In interrupt handling function, 24-bit data is read from address 0x648~0x64a to check which IRQ source is valid; if data bit[18] is 1, it means the irq_gpio IRQ source is valid. Clear this interrupt source by setting address 0x64a bit[2] as 1b'1.

As for level-type interrupt, IRQ interrupt source status needs to be cleared via setting corresponding module status register. Take Timer0 IRQ interrupt source for example: First enable the interrupt source by setting address 0x640 bit[0] as 1b'1; then set address 0x643 bit[0] as 1b'1 to enable the interrupt. In interrupt handling function, 24-bit data is read from address 0x648~0x64a to check which IRQ source is valid; if data bit[0] is 1, it means the Timer0 IRQ source is valid. Register TMR_STATUS (address 0x623) [0] should be written with 1b'1 to manually clear Timer0 status (refer to section 5.1.1 **Register table**).

7 Interface

7.1 GPIO

The TLSR8367EP16 support up to 9 GPIOs respectively. All digital IOs including PA[0]~PD[3] and can be used as GPIOs (general purpose IOs).

7.1.1 Basic configuration

Please refer to the table in **section 7.1.1.1** for various GPIO interface configuration.

7.1.1.1 GPIO lookup table

Table 7- 1GPIO lookup table

Pin	Default function	Pad Function Mux					GPIO Setting						
		Register=3	Register=2	Register=1	Register=0	Register	Input (R)	IE	OEN	Output	Polarity	DS	Act as GPIO
PWM3/ PWM0/ RX_CYC2LNA/ PA[0]	GPIO	/	RX_CYC2LNA	PWM0	PWM3	0x5a8[1:0]	0x580[0]	afe_0xb6 [0]	0x582[0]	0x583[0]	0x584[0]	afe_0xb8 [0]	0x586[0]
PWM3_N/ PA[1]	GPIO	Rsvd	Rsvd	/	PWM3_N	0x5a8[3:2]	0x580[1]	afe_0xb6 [1]	0x582[1]	0x583[1]	0x584[1]	afe_0xb8 [1]	0x586[1]
PWM1_N/ pga_in<0>/PA[2]	GPIO	Rsvd	Rsvd	/	PWM1_N	0x5a8[5:4]	0x580[2]	afe_0xb6 [2]	0x582[2]	0x583[2]	0x584[2]	afe_0xb8 [2]	0x586[2]
PWM4/ I2C_CK/ pga_in<1>/PA[3]	GPIO	Rsvd	Rsvd	I2C_CK	PWM4	0x5a8[7:6]	0x580[3]	afe_0xb6 [3]	0x582[3]	0x583[3]	0x584[3]	afe_0xb8 [3]	0x586[3]
PWM2/ I2C_SD/ PA[4]	GPIO	Rsvd	Rsvd	I2C_SD	PWM2	0x5a9[1:0]	0x580[4]	afe_0xb6 [4]	0x582[4]	0x583[4]	0x584[4]	afe_0xb8 [4]	0x586[4]
PWM2_N/ I2C_CK/ I2C_MCK/ PA[5]	GPIO	Rsvd	I2C_MCK	I2C_CK	PWM2_N	0x5a9[3:2]	0x580[5]	afe_0xb6 [5]	0x582[5]	0x583[5]	0x584[5]	afe_0xb8 [5]	0x586[5]
PWM4_N/ I2C_SD/ I2C_MSD/ PA[6]	GPIO	Rsvd	I2C_MSD	I2C_SD	PWM4_N	0x5a9[5:4]	0x580[6]	afe_0xb6 [6]	0x582[6]	0x583[6]	0x584[6]	afe_0xb8 [6]	0x586[6]
PWM0/ TX_CYC2PA/ sar_ain<1>/PA[7]	GPIO	Rsvd	TX_CYC2PA	Rsvd	PWM0	0x5a9[7:6]	0x580[7]	afe_0xb6 [7]	0x582[7]	0x583[7]	0x584[7]	afe_0xb8 [7]	0x586[7]

Pin	Default function	Pad Function Mux					GPIO Setting						
		Register=3	Register=2	Register=1	Register=0	Register	Input (R)	IE	OEN	Output	Polarity	DS	Act as GPIO
PWM4/ MCN/ RX_CYC2LNA/ sar_ain<2>/PB[0]	GPIO	Rsvd	RX_CYC2LNA	MCN	PWM4	0x5aa[1:0]	0x588[0]	afe_0xb9 [0]	0x58a[0]	0x58b[0]	0x58c[0]	afe_0xbb [0]	0x58e[0]
PWM1/ MDO/ TX_CYC2PA/ sar_ain<3>/PB[1]	GPIO	Rsvd	TX_CYC2PA	MDO	PWM1	0x5aa[3:2]	0x588[1]	afe_0xb9 [1]	0x58a[1]	0x58b[1]	0x58c[1]	afe_0xbb [1]	0x58e[1]
PWM0/ MDI/ sar_ain<4>/PB[2]	GPIO	Rsvd	/	MDI	PWM0	0x5aa[5:4]	0x588[2]	afe_0xb9 [2]	0x58a[2]	0x58b[2]	0x58c[2]	afe_0xbb [2]	0x58e[2]
PWM3_N/ MCK/ PWM2/ sar_ain<5>/PB[3]	GPIO	Rsvd	PWM2	MCK	PWM3_N	0x5aa[7:6]	0x588[3]	afe_0xb9 [3]	0x58a[3]	0x58b[3]	0x58c[3]	afe_0xbb [3]	0x58e[3]
PWM2_N/ I2C_MCK/ UART_TX/ sar_ain<6>/pga_in<3>/PB[4]	GPIO	Rsvd	UART_TX	I2C_MCK	PWM2_N	0x5ab[1:0]	0x588[4]	afe_0xb9 [4]	0x58a[4]	0x58b[4]	0x58c[4]	afe_0xbb [4]	0x58e[4]
PWM4/ I2C_MSD/ UART_RX/ sar_ain<7>/pga_in<2>/PB[5]	GPIO	Rsvd	UART_RX	I2C_MSD	PWM4	0x5ab[3:2]	0x588[5]	afe_0xb9 [5]	0x58a[5]	0x58b[5]	0x58c[5]	afe_0xbb [5]	0x58e[5]
PWM0_N/ I2C_MCK/ UART_RTS/ sar_ain<8>/PB[6]	GPIO	Rsvd	UART_RTS	I2C_MCK	PWM0_N	0x5ab[5:4]	0x588[6]	afe_0xb9 [6]	0x58a[6]	0x58b[6]	0x58c[6]	afe_0xbb [6]	0x58e[6]
PWM1/ I2C_MSD/ UART_CTS/ sar_ain<9>/PB[7]	GPIO	Rsvd	UART_CTS	I2C_MSD	PWM1	0x5ab[7:6]	0x588[7]	afe_0xb9 [7]	0x58a[7]	0x58b[7]	0x58c[7]	afe_0xbb [7]	0x58e[7]
PC[0]	GPIO	/	/	/	/	0x5ac[1:0]	0x590[0]	0x591[0]	0x592[0]	0x593[0]	0x594[0]	0x595[0]	0x596[0]
PWM2_N/ PC[1]	GPIO	/	Rsvd	Rsvd	PWM2_N	0x5ac[3:2]	0x590[1]	0x591[1]	0x592[1]	0x593[1]	0x594[1]	0x595[1]	0x596[1]

Pin	Default function	Pad Function Mux					GPIO Setting						
		Register=3	Register=2	Register=1	Register=0	Register	Input (R)	IE	OEN	Output	Polarity	DS	Act as GPIO
CN/ PWM1/ MCN/ UART_CTS/ PC[2]	CN	UART_CTS	MCN	PWM1	CN	0x5ac[5:4]	0x590[2]	0x591[2]	0x592[2]	0x593[2]	0x594[2]	0x595[2]	0x596[2]
DO/ PWM0_N/ MDO/ UART_RTS/ PC[3]	DO	UART_RTS	MDO	PWM0_N	DO	0x5ac[7:6]	0x590[3]	0x591[3]	0x592[3]	0x593[3]	0x594[3]	0x595[3]	0x596[3]
DI/I2C_SD/ I2C_MSD/ MDI/ UART_TX/ PC[4]	DI	UART_TX	MDI	I2C_MSD	DI/I2C_SD	0x5ad[1:0]	0x590[4]	0x591[4]	0x592[4]	0x593[4]	0x594[4]	0x595[4]	0x596[4]
CK/I2C_CK/ I2C_MCK/ MCK/ UART_RX/ PC[5]	CK	UART_RX	MCK	I2C_MCK	CK/I2C_CK	0x5ad[3:2]	0x590[5]	0x591[5]	0x592[5]	0x593[5]	0x594[5]	0x595[5]	0x596[5]
PWM4/ PC[6]	GPIO	/	/	Rsvd	PWM4	0x5ad[5:4]	0x590[6]	0x591[6]	0x592[6]	0x593[6]	0x594[6]	0x595[6]	0x596[6]
SWS/ PWM3/ sar_ain<0>/PC[7]	SWS	/	/	PWM3	SWS	0x5ad[7:6]	0x590[7]	0x591[7]	0x592[7]	0x593[7]	0x594[7]	0x595[7]	0x596[7]
PWM1/ UART_CTS/ PWM0_N/ PD[0]	GPIO	/	PWM0_N	UART_CTS	PWM1	0x5ae[1:0]	0x598[0]	0x599[0]	0x59a[0]	0x59b[0]	0x59c[0]	0x59d[0]	0x59e[0]
PWM0/ UART_RTS/ PWM1_N/ PD[1]	GPIO	/	PWM1_N	UART_RTS	PWM0	0x5ae[3:2]	0x598[1]	0x599[1]	0x59a[1]	0x59b[1]	0x59c[1]	0x59d[1]	0x59e[1]
PWM3/ UART_TX/ PWM2/ PD[2]	GPIO	/	PWM2	UART_TX	PWM3	0x5ae[5:4]	0x598[2]	0x599[2]	0x59a[2]	0x59b[2]	0x59c[2]	0x59d[2]	0x59e[2]

Pin	Default function	Pad Function Mux					GPIO Setting						
		Register=3	Register=2	Register=1	Register=0	Register	Input (R)	IE	OEN	Output	Polarity	DS	Act as GPIO
PWM0/ UART_RX/ TX_CYC2PA/ PD[3]	GPIO	/	TX_CYC2PA	UART_RX	PWM0	0x5ae[7:6]	0x598[3]	0x599[3]	0x59a[3]	0x59b[3]	0x59c[3]	0x59d[3]	0x59e[3]
MSCN/ PE[0]	MSCN	/	/	/	MSCN		0x5a0[0]	0x5a1[0]	0x5a2[0]	0x5a3[0]	0x5a4[0]	0x5a5[0]	0x5a6[0]
MSDI/ PE[1]	MSDI	/	/	/	MSDI		0x5a0[1]	0x5a1[1]	0x5a2[1]	0x5a3[1]	0x5a4[1]	0x5a5[1]	0x5a6[1]
MSDO/ PE[2]	MSDO	/	/	/	MSDO		0x5a0[2]	0x5a1[2]	0x5a2[2]	0x5a3[2]	0x5a4[2]	0x5a5[2]	0x5a6[2]
MCLK/ PE[3]	MCLK	/	/	/	MCLK		0x5a0[3]	0x5a1[3]	0x5a2[3]	0x5a3[3]	0x5a4[3]	0x5a5[3]	0x5a6[3]

***Notes:**

- (1) All the registers in this table (IE, OEN, Register, Output, Input, DS, Act as GPIO, Polarity) can be set independently.
- (2) IE: Input enable, high active. 1: enable input, 0: disable input.
- (3) OEN: Output enable, low active. 0: enable output, 1: disable output.
- (4) Register: Configure multiplexed functions in “Pad Function Mux” column.
- (5) Output: configure GPO output.
- (6) Input: read GPI input.
- (7) DS: Drive strength. Default: 1.
- (8) Act as GPIO: enable (1) or disable (0) GPIO function.
- (9) Polarity: see **section 7.1.2 Connection relationship between GPIO and related modules**.
- (10) Default function: By default, PC[2]~PC[5] are used as SPI Slave function, PC[7] is used as SWS function are used as MSPI function, while the other GPIOs are used as GPIO function.
- (11) Priority: “Act as GPIO” has the highest priority. To configure as multiplexed function, disable GPIO function first.
- (12) For all unused GPIOs, corresponding “IE” must be set as 0.
- (13) When SWS/PC[7] “IE” is set as 1, this pin must be fixed as pull-up/pull-down state (float state is not allowed).
- (14) afe_0xb6, afe_0xb8, afe_0xb9 and afe_0xbb marked in red color are analog registers; others are digital registers.
- (15) Rsvd: reserved for internal use.

7.1.1.2 Multiplexed functions

Each pin listed in Table 7-1 acts as the function in the “**Default Function**” column by default. By default, PC[2]~PC[5] are used as SPI Slave function, PC[7] is used as SWS function, while the other GPIOs are used as GPIO function.

If a pin with multiplexed functions does not act as GPIO function by default, to use it as GPIO, first set the bit in “**Act as GPIO**” column as 1b’1. After GPIO function is enabled, if the pin is used as output, both the bits in “**IE**” and “**OEN**” columns should be set as 1b’0, then set the register value in the “**Output**” column; if the pin is used as input, both the bits in “**IE**” and “**OEN**” columns should be set as 1b’1, and the input data can be read from the register in the “**Input**” column.

To use a pin as certain multiplexed function (neither the default function nor GPIO function), first clear the bit in “**Act as GPIO**” column to disable GPIO function, and then configure “**Register**” in “Pad Function Mux” column to enable multiplexed function correspondingly.

Example 1: PWM3/PWM0/RX_CYC2LNA/PA[0].

- (1) This pin acts as GPIO function by default.
 - ✧ To use this pin as general output, both address afe_0xb6[0] (IE) and 0x582[0] (OEN) should be set as 1b’0, then configure address 0x583[0] (Output).
 - ✧ To use this pin as general input, both address afe_0xb6[0] (IE) and 0x582[0] (OEN) should be set as 1b’1, and the input data can be read from address 0x580[0] (Input).
- (2) To use this pin as PWM3 function, address 0x586[0] (Act as GPIO) should be set as 1b’0, and 0x5a8[1:0] (Register) should be set as 2b’00.
- (3) To use this pin as PWM0 function, address 0x586[0] (Act as GPIO) should be set as 1b’0, and 0x5a8[1:0] (Register) should be set as 2b’01.
- (4) To use this pin as RX_CYC2LNA function, address 0x586[0] (Act as GPIO) should be set as 1b’0, and 0x5a8[1:0] (Register) should be set as 2b’10.

Example 2: CN/PWM1/MCN/UART_CTS/PC[2].

- (1) This pin acts as SPI Slave CN function by default (0x596[2]=1b’0, 0x5ac[5:4]=2b’00).
- (2) To use this pin as GPIO function, first set address 0x596[2] (Act as GPIO) as 1b’1.
 - ✧ If the pin is used as general output, both address 0x591[2] (IE) and 0x592[2] (OEN) should be set as 1b’0, then configure address 0x593[2] (Output).
 - ✧ If the pin is used as general input, both address 0x591[2] (IE) and 0x592[2] (OEN) should be set to 1b’1, and the input data can be read from address 0x590[2] (Input).
- (3) To use it as PWM1 function, set address 0x596[2] (Act as GPIO) as 1b’0, and set 0x5ac[5:4] (Register) to 2b’01.
- (4) To use it as SPI Master MCN function, set address 0x596[2] (Act as GPIO) as 1b’0, and set 0x5ac[5:4] (Register) to 2b’10.
- (5) To use it as UART_CTS function, set address 0x596[2] (Act as GPIO) as 1b’0, and set 0x5ac[5:4] (Register) to 2b’11.

7.1.1.3 Drive strength

The registers in the “DS” column are used to configure the corresponding pin’s driving strength: “1” indicates maximum drive level, while “0” indicates minimal drive level.

The “DS” configuration will take effect when the pin is used as output. It’s set as the strongest driving level by default. In actual applications, driving strength can be decreased to lower level if necessary.

PA[0] ~ PD[3] support drive strength up to 8mA (8mA when “DS”=1, 4mA when “DS”=0).

7.1.2 Connection relationship between GPIO and related modules

GPIO can be used to generate GPIO interrupt signal for interrupt system, counting or control signal for Timer/Counter module, or GPIO2RISC interrupt signal for interrupt system.

For the “Exclusive Or (XOR)” operation result for input signal from any GPIO pin and respective “Polarity” value, on one hand, it takes “And” operation with “irq” and generates GPIO interrupt request signal; on the other hand, it takes “And” operation with “m0/m1/m2”, and generates counting signal in Mode 1 or control signal in Mode 2 for Timer0/Timer1/Timer2, or generates GPIO2RISC[0]/GPIO2RISC[1]/GPIO2RISC[2] interrupt request signal.

GPIO interrupt request signal = $| ((input \wedge polarity) \& irq);$

Counting (Mode 1) or control (Mode 2) signal for Timer0 = $| ((input \wedge polarity) \& m0);$

Counting (Mode 1) or control (Mode 2) signal for Timer1 = $| ((input \wedge polarity) \& m1);$

Counting (Mode 1) or control (Mode 2) signal for Timer2 = $| ((input \wedge polarity) \& m2);$

GPIO2RISC[0] interrupt request signal = $| ((input \wedge polarity) \& m0);$

GPIO2RISC[1] interrupt request signal = $| ((input \wedge polarity) \& m1);$

GPIO2RISC[2] interrupt request signal = $| ((input \wedge polarity) \& m2);$

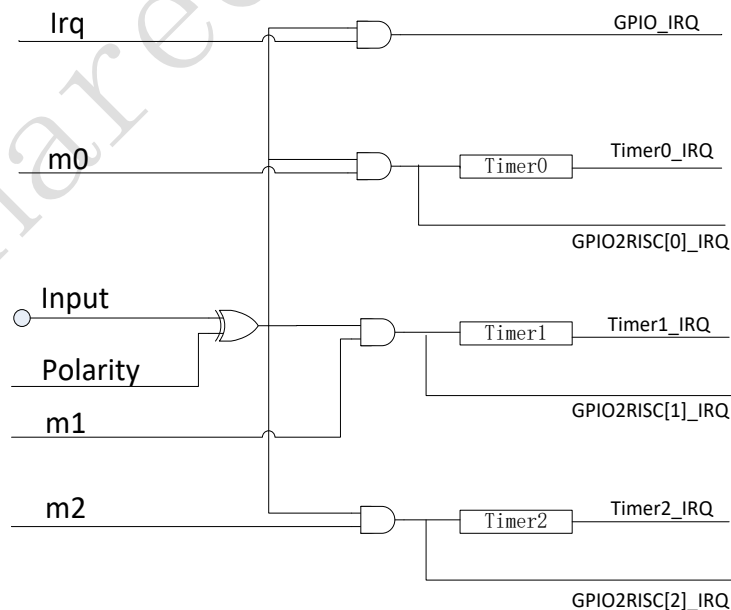

Figure 7- 1 Logic relationship between GPIO and related modules

Please refer to Table 7- 2 and Table 6- 1 to learn how to configure GPIO for interrupt system or Timer/Counter (Mode 1 or Mode 2).

- (1) First enable GPIO function, enable IE and disable OEN. Please see section 7.1.1 Basic configuration.

- (2) GPIO IRQ signal:

Select GPIO interrupt trigger edge (positive edge or negative edge) via configuring “**Polarity**”, and set corresponding GPIO interrupt enabling bit “**Irq**”.

Then set address 0x5b5[3] to enable GPIO IRQ.

Finally enable GPIO interrupt (irq_gpio) via MASK_2 (address 0x642[2]).

User can read addresses 0x5e0 ~ 0x5e3 to see which GPIO asserts GPIO interrupt request signal.

Note: 0x5e0[7:0]-->PA[7]~PA[0], 0x5e1[7:0]-->PB[7]~PB[0], 0x5e2[7:0]-->PC[7]~PC[0], PD[3]~PD[0]}.

Please ignore the GPIO herein which is not mentioned in the datasheet.

- (3) Timer/Counter counting or control signal:

Configure “**Polarity**”. In Timer Mode 1, it determines GPIO edge when Timer Tick counting increases. In Timer Mode 2, it determines GPIO edge when Timer Tick starts counting.

Then set “**m0/m1/m2**” to specify the GPIO which generates counting signal (Mode 1)/control signal (Mode 2) for Timer0/Timer1/Timer2.

User can read addresses 0x5e8~0x5eb/0x5f0~0x5f3/0x5f8~0x5fb to see which GPIO asserts counting signal (in Mode 1) or control signal (in Mode 2) for Timer0/Timer1/Timer2.

Note: Timer0: 0x5e8[7:0]-->PA[7]~PA[0], 0x5e9[7:0]-->PB[7]~PB[0], 0x5ea[7:0]-->PC[7]~PC[0], PD[3]~PD[0]}; Timer1: 0x5f0[7:0]-->PA[7]~PA[0], 0x5f1[7:0]-->PB[7]~PB[0], 0x5f2[7:0]-->PC[7]~PC[0], PD[3]~PD[0]}; Timer2: 0x5f8[7:0]-->PA[7]~PA[0], 0x5f9[7:0]-->PB[7]~PB[0], 0x5fa[7:0]-->PC[7]~PC[0], PD[3]~PD[0]}.

- (4) GPIO2RISC IRQ signal:

Select GPIO2RISC interrupt trigger edge (positive edge or negative edge) via configuring “**Polarity**”, and set corresponding GPIO enabling bit “**m0**”/“**m1**”/“**m2**”.

Enable GPIO2RISC[0]/GPIO2RISC[1]/GPIO2RISC[2] interrupt via MASK_2, i.e. “gpio2risc[0]” (address 0x642[5]) / “gpio2risc[1]” (address 0x642[6]) / “gpio2risc[2]” (address 0x642[7]).

Table 7- 2GPIO lookup table2

Pin	Input (R)	Polarity 1: active low 0: active high	Irq	m0	m1	m2
PA[0]	0x580[0]	0x584[0]	0x587[0]	0x5b8[0]	0x5c0[0]	0x5c8[0]
PA[1]	0x580[1]	0x584[1]	0x587[1]	0x5b8[1]	0x5c0[1]	0x5c8[1]
PA[2]	0x580[2]	0x584[2]	0x587[2]	0x5b8[2]	0x5c0[2]	0x5c8[2]
PA[3]	0x580[3]	0x584[3]	0x587[3]	0x5b8[3]	0x5c0[3]	0x5c8[3]
PA[4]	0x580[4]	0x584[4]	0x587[4]	0x5b8[4]	0x5c0[4]	0x5c8[4]
PA[5]	0x580[5]	0x584[5]	0x587[5]	0x5b8[5]	0x5c0[5]	0x5c8[5]
PA[6]	0x580[6]	0x584[6]	0x587[6]	0x5b8[6]	0x5c0[6]	0x5c8[6]
PA[7]	0x580[7]	0x584[7]	0x587[7]	0x5b8[7]	0x5c0[7]	0x5c8[7]
PB[0]	0x588[0]	0x58c[0]	0x58f[0]	0x5b9[0]	0x5c1[0]	0x5c9[0]
PB[1]	0x588[1]	0x58c[1]	0x58f[1]	0x5b9[1]	0x5c1[1]	0x5c9[1]
PB[2]	0x588[2]	0x58c[2]	0x58f[2]	0x5b9[2]	0x5c1[2]	0x5c9[2]
PB[3]	0x588[3]	0x58c[3]	0x58f[3]	0x5b9[3]	0x5c1[3]	0x5c9[3]
PB[4]	0x588[4]	0x58c[4]	0x58f[4]	0x5b9[4]	0x5c1[4]	0x5c9[4]
PB[5]	0x588[5]	0x58c[5]	0x58f[5]	0x5b9[5]	0x5c1[5]	0x5c9[5]
PB[6]	0x588[6]	0x58c[6]	0x58f[6]	0x5b9[6]	0x5c1[6]	0x5c9[6]
PB[7]	0x588[7]	0x58c[7]	0x58f[7]	0x5b9[7]	0x5c1[7]	0x5c9[7]
PC[0]	0x590[0]	0x594[0]	0x597[0]	0x5ba[0]	0x5c2[0]	0x5ca[0]
PC[1]	0x590[1]	0x594[1]	0x597[1]	0x5ba[1]	0x5c2[1]	0x5ca[1]
PC[2]	0x590[2]	0x594[2]	0x597[2]	0x5ba[2]	0x5c2[2]	0x5ca[2]
PC[3]	0x590[3]	0x594[3]	0x597[3]	0x5ba[3]	0x5c2[3]	0x5ca[3]
PC[4]	0x590[4]	0x594[4]	0x597[4]	0x5ba[4]	0x5c2[4]	0x5ca[4]
PC[5]	0x590[5]	0x594[5]	0x597[5]	0x5ba[5]	0x5c2[5]	0x5ca[5]
PC[6]	0x590[6]	0x594[6]	0x597[6]	0x5ba[6]	0x5c2[6]	0x5ca[6]
PC[7]	0x590[7]	0x594[7]	0x597[7]	0x5ba[7]	0x5c2[7]	0x5ca[7]
PD[0]	0x598[0]	0x59c[0]	0x59f[0]	0x5bb[0]	0x5c3[0]	0x5cb[0]
PD[1]	0x598[1]	0x59c[1]	0x59f[1]	0x5bb[1]	0x5c3[1]	0x5cb[1]
PD[2]	0x598[2]	0x59c[2]	0x59f[2]	0x5bb[2]	0x5c3[2]	0x5cb[2]
PD[3]	0x598[3]	0x59c[3]	0x59f[3]	0x5bb[3]	0x5c3[3]	0x5cb[3]
PE[0]	0x5a0[0]	0x5a4[0]	0x5a7[0]	0x5bb[4]	0x5c3[4]	0x5cb[4]
PE[1]	0x5a0[1]	0x5a4[1]	0x5a7[1]	0x5bb[5]	0x5c3[5]	0x5cb[5]
PE[2]	0x5a0[2]	0x5a4[2]	0x5a7[2]	0x5bb[6]	0x5c3[6]	0x5cb[6]
PE[3]	0x5a0[3]	0x5a4[3]	0x5a7[3]	0x5bb[7]	0x5c3[7]	0x5cb[7]

7.1.3 Pull-up/Pull-down resistor

The GPIOs including PA[5]~PA[7] and PB[0]~PB[7] support configurable pull-up resistor of rank x1 and x100 or pull-down resistor of rank x10 which are all disabled by default. Analog registers afe_0x08~afe_0x0a[5:0] serve to control the pull-up/pull-down resistor for each of these GPIOs.

The GPIOs including PA[0]~PA[4], PC[0]~PC[7] and PD[0]~PD[3] support pull-down resistor of rank x10 which are all disabled by default. Analog registers including afe_0x0a[7:6], afe_0x0b[7:0] and afe_0x0c[6:0] serve to control the pull-down resistor for each of these GPIOs.

Please refer to Table 7-3 for details.

Take the PB[0] for an example: Setting analog register afe_0x08[1:0] to 2b'01/2b'10/2b'11 is to respectively enable pull-up resistor of rank x100 / pull-up resistor of rank x1 / pull-down resistor of rank x10 for PB[0]; Clearing the two bits (default value) disables pull-up and pull-down resistor for PB[0].

Take the PA[0] for another example: Setting analog register afe_0x0a[6] to 1b'1 is to enable pull-down resistor of rank x10 for PA[0]; Clearing the bit (default value) disables pull-down resistor for PA[0].

Table 7- 3 Analog registers for pull-up/pull-down resistor control

Address	Mnemonic	Default	Description
afe_0x08<1:0>	pullupdown_ctrl<1:0>	00	PB[0] pull up/down control 00 – No pull up/down resistor 01 –x100 pull-up resistor 10 – x1 pull-up resistor 11 – x10 pull-down resistor
afe_0x08<3:2>	pullupdown_ctrl<1:0>	00	PB[1] pull up/down control 00 – No pull up/down resistor 01 –x100 pull-up resistor 10 – x1 pull-up resistor 11 – x10 pull-down resistor
afe_0x08<5:4>	pullupdown_ctrl<1:0>	00	PB[2] pull up/down control 00 – No pull up/down resistor 01 – x100 pull-up resistor 10 – x1 pull-up resistor 11 – x10 pull-down resistor
afe_0x08<7:6>	pullupdown_ctrl<1:0>	00	PB[3] pull up/down control 00 – No pull up/down resistor 01 – x100 pull-up resistor 10 – x1 pull-up resistor 11 – x10 pull-down resistor
afe_0x09<1:0>	pullupdown_ctrl<1:0>	00	PB[4] pull up/down control 00 – No pull up/down resistor 01 – x100 pull-up resistor 10 – x1 pull-up resistor 11 – x10 pull-down resistor

Address	Mnemonic	Default	Description
afe_0x09<3:2>	pullupdown_ctrl<1:0>	00	PB[5] pull up/down control 00 – No pull up/down resistor 01 – x100 pull-up resistor 10 – x1 pull-up resistor 11 – x10 pull-down resistor
afe_0x09<5:4>	pullupdown_ctrl<1:0>	00	PB[6] pull up/down control 00 – No pull up/down resistor 01 – x100 pull-up resistor 10 – x1 pull-up resistor 11 – x10 pull-down resistor
afe_0x09<7:6>	pullupdown_ctrl<1:0>	00	PB[7] pull up/down control 00 – No pull up/down resistor 01 – x100 pull-up resistor 10 – x1 pull-up resistor 11 – x10 pull-down resistor
afe_0x0a<1:0>	pullupdown_ctrl<1:0>	00	PA[5] pull up/down control 00 – No pull up/down resistor 01 – x100 pull-up resistor 10 – x1 pull-up resistor 11 – x10 pull-down resistor
afe_0x0a<3:2>	pullupdown_ctrl<1:0>	00	PA[6] pull up/down control 00 – No pull up/down resistor 01 – x100 pull-up resistor 10 – x1 pull-up resistor 11 – x10 pull-down resistor
afe_0x0a<5:4>	pullupdown_ctrl<1:0>	00	PA[7] pull up/down control 00 – No pull up/down resistor 01 – x100 pull-up resistor 10 – x1 pull-up resistor 11 – x10 pull-down resistor
afe_0x0a<7:6>	pulldown_ctrl<1:0>	00	PA[1]~PA[0] pull down control 0– No pull down resistor 1 – Enable x10 pull-down resistor
afe_0x0b<7:0>	pulldown_ctrl<7:0>	0x00	{PC[4]~ PC[0], PA[4]~ PA[2]} pull down control 0– No pull down resistor 1 – Enable x10 pull-down resistor
afe_0x0c<6:0>	pulldown_ctrl<6:0>	000000	{PD[3]~ PD[0], PC[7]~ PC[5]} pull down control 0– No pull down resistor 1 – Enable x10 pull-down resistor

7.2 SWS

The TLSR8367 supports Single Wire Slave (SWS) interface for debugging. SWS represents the Slave device of the single wire communication system developed by Telink. The maximum data rate can be up to 2Mbps.

SWS usage is not supported in power-saving mode (deep sleep or suspend). The TLSR8367 has to be waked up by using IO or 32k RC wakeup, so that it can respond to the Swire commands for debug/programming.

7.3 I2C

The TLSR8367 embeds I2C hardware module, which could act as Master mode or Slave mode. I2C is a popular inter-IC interface requiring only 2 bus lines, a serial data line (SDA) and a serial clock line (SCL).

I2CSCT (address 0x03) bit[1] and bit[4] serves to select I2C Master mode or Slave mode. By default, 0x03 bit[4] is set as 1b'1 and bit[1] is set as 1b'0, therefore I2C module of the TLSR8367 acts as Slave mode by default.

7.3.1 Communication protocol

Telink I2C module supports standard mode (100kbps) and Fast-mode (400kbps) with restriction that system clock must be by at least 10x of data rate.

Two wires, SDA and SCL (SCK) carry information between Master device and Slave device connected to the bus. Each device is recognized by unique address (ID). Master device is the device which initiates a data transfer on the bus and generates the clock signals to permit that transfer. Slave device is the device addressed by a Master.

Both SDA and SCL are bidirectional lines connected to a positive supply voltage via a pull-up resistor. It's recommended to use external 3.3kohm pull-up resistor. For standard mode, the internal pull-up resistor of rank x1 can be used instead of the external 3.3kohm pull-up.

When the bus is free, both lines are HIGH. It's noted that data in SDA line must keep stable when clock signal in SCL line is at high level, and level state in SDA line is only allowed to change when clock signal in SCL line is at low level.

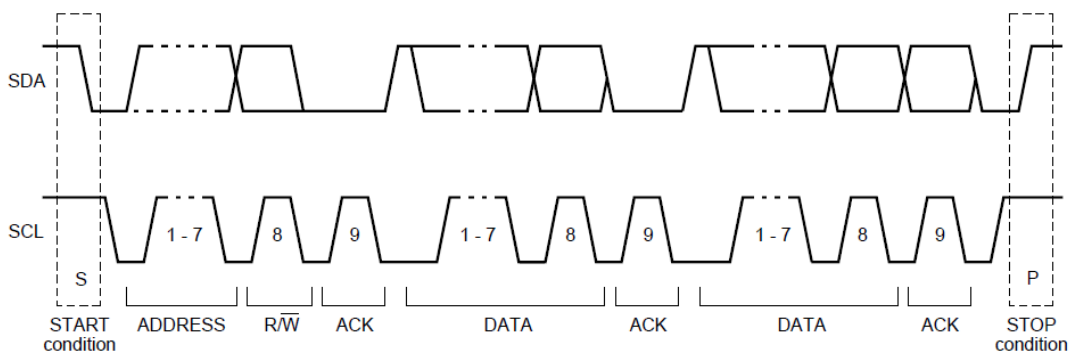

Figure 7-2 I2C timing chart

7.3.2 Register table

Table 7- 4 Register configuration for I2C

Address	Name	R/W	Description	Reset Value
0x00	I2CSP	RW	I2C master clock speed	0x1f
0x01	I2CMID	RW	[7:1] I2C master ID	0x5c
0x02	I2CMST	RW	[0]: master busy [1]: master packet busy [2]: master received status 0 for ACK; 1 for NAK	0x00
0x03	I2CSCT	RW	[0]: address auto increase enable [1]: I2C master enable (1) [2]: sub-mode select in I2C slave mode 0- DMA mode 1- Mapping Mode [4]: I2C slave enable (1)	0x11
0x04	I2CAD	RW	[7:0] Data buffer in master mode	0x5a
0x05	I2CDW	RW	[7:0] Data buffer in master mode	0xf1
0x06	I2CDR	RW	[7:0] Data buffer for Read or Write in master mode	0x00
0x07	I2CCLT	RW	[0]: launch ID cycle [1]: launch address cycle (send I2CAD data) [2]: launch data write cycle [3]: launch data read cycle For Master Write: 0: I2CAD&I2CDW, 1: I2CAD&I2CDW&I2CDR) To write 3 bytes: bit[3]=1; To write 2 bytes: bit[3]=0. For Master Read: always 1. [4]: launch start cycle [5]: launch stop cycle [6]: enable read ID [7]: enable ACK in read command	0x00
0x20	ADROFFSET	RO	[6:0] mapped host address offset	0x00
0x21	HOSTIRQ	RO	[0]: host cmd irq flag, I2C host operation have happened. Write 1 to clear. [1]: host read flag, I2C host operation have happened and is read operation. Write 1 to clear [2]: software irq flag, write 1 to clear [3]: software irq, write 1 to set	0x00
0x22	MAPADRL	R/W	Low byte of Mapping mode buffer address	0x80
0x23	MAPADRH	R/W	High byte of Mapping mode buffer address	0x9f

7.3.3 I2C Slave mode

I2C module of the TLSR8367 acts as Slave by default (Address 0x03[4] should be set as 1b'1 to enable I2C Slave mode).

I2C slave address can be configured via register I2CID (address 0x01) [7:1].

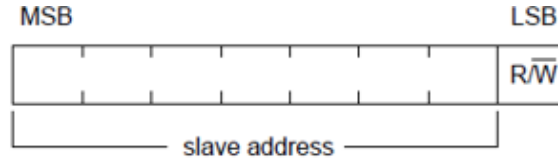

Figure 7-3 Byte consisted of slave address and R/W flag bit

I2C slave mode supports two sub modes including Direct Memory Access (DMA) mode and Mapping mode, which is selectable via I2CSCT (address 0x03) bit[2].

In I2C Slave mode, Master could initiate transaction anytime. I2C slave module will reply with ACK automatically. To monitor the start of I2C transaction, user could set interrupt from GPIO for SCA or SCL.

7.3.3.1 DMA mode

By default, I2CSCT (address 0x03) bit[2] is set as 1b'0, therefore DMA mode is selected by default.

In DMA mode, other devices (Master) could access (read/write) designated address in Register and/or SRAM of the TLSR8369 according to I2C protocol. I2C module of the TLSR8367 will execute the read/write command from I2C Master automatically. But user needs to notice that the system clock shall be at least 10x faster than I2C bit rate.

The access address designated by Master is offset by 0x800000. In the TLSR8367, Register address starts from 0x800000 and SRAM address starts from 0x808000. For example, if Addr High(AddrH) is 0xaa and Addr Low (AddrL) is 0xcc, the real address of accessed data is 0x80aacc.

In DMA mode, Master could read/write data byte by byte. The designated access address is initial address and it supports auto increment by setting I2CSCT (address 0x03) bit[0] to 1b'1.

Read Format in DMA mode

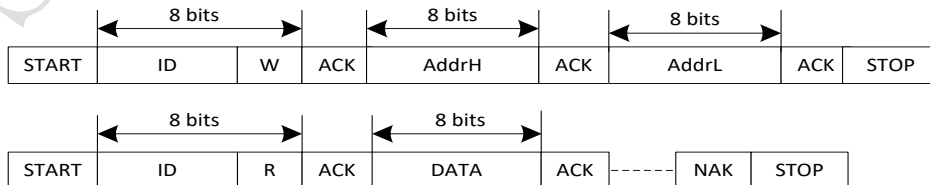

Figure 7-4 Read format in DMA mode

Write Format in DMA mode



Figure 7- 5 Write format in DMA mode

7.3.3.2 Mapping mode

Mapping mode could be enabled via setting register I2CSCT (address 0x03) bit[2] as 1b'1.

In Mapping mode, data written and read by I2C master will be redirected to specified 128-byte buffer in SRAM. User could specify the initial address of the buffer by configuring registers MAPADR1 (address 0x22, lower byte) and MAPADRH (address 0x23, higher byte). The first 64-byte buffer is for written data and following 64-byte buffer is for read data. Every time the data access will start from the beginning of the Write-buffer/Read-buffer after I2C stop condition occurs. The last accessed data address could be checked in register ADROFFSET (address 0x20) [6:0] which is only updated after I2C STOP occurs.

Read Format in mapping mode

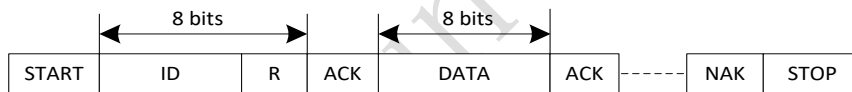

Figure 7- 6 Read format in Mapping mode

Write Format in mapping mode

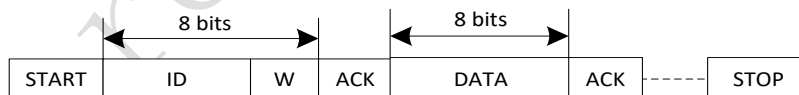

Figure 7- 7 Write format in Mapping mode

7.3.4 I2C Master mode

I2CSCT (address 0x03) bit[1] should be set as 1b'1 to enable I2C master mode for the TLSR8367.

Address 0x00 serves to set I2C Master clock: $F_{I2C} = \text{System Clock} / (4 * \text{clock speed configured in address 0x00})$.

A complete I2C protocol contains START, Slave Address, R/W bit, data, ACK and STOP. Slave address could be configured via address 0x01[7:1].

I2C Master (i.e. I2C module of the TLSR8367) could send START, Slave Address, R/W bit, data and STOP cycle by configuring address 0x07. I2C master will send enabled cycles in the correct sequence.

Address 0x02 serves to indicate whether Master/Master packet is busy, as well as Master received status. Bit[0] will be set to 1 when one byte is being sent, and this bit can be automatically cleared after a start signal/ address byte/acknowledge signal/data /stop signal is sent. Bit[1] is set to 1 when the start signal is sent, and this bit will be automatically cleared after the stop signal is sent. Bit[2] indicates whether to succeed in sending acknowledgement signal.

7.3.4.1 I2C Master Write transfer

I2C Master has 3-byte buffer for write data, which are I2CAD (0x04), I2CDW (0x05) and I2CDR (0x06). Write transfer will be completed by I2C master module.

For example, to implement an I2C write transfer with 3-byte data, which contains START, Slave Address, Write bit, ack from Slave, 1st byte, ack from slave, 2nd byte, ack from slave, 3rd byte, ack from slave and STOP, user needs to configure I2C slave address to I2CID (0x01) [7:1], 1st byte data to I2CAD, 2nd byte data to I2CDW and 3rd byte to I2CDR. To start I2C write transfer, I2CCLT (0x07) is configured to 0x3f (0011 1111). I2C Master will launch START, Slave address, Write bit, load ACK to I2CMST (0x02) [2], send I2CAD data, load ACK to I2CMST[2], send I2CDW data, load ACK to I2CMST[2], send I2CDR data, load ACK to I2CMST[2] and then STOP sequentially.

For I2C write transfer whose data are more than 3 bytes, user could split the cycles according to I2C protocol.

7.3.4.2 I2C Master Read transfer

I2C Master has one byte buffer for read data, which is I2CDR (0x06). Read transfer will be completed by I2C Master.

For example, to implement an I2C read transfer with 1 byte data, which contains START, Slave Address, Read bit, Ack from Slave, 1st byte from Slave, Ack by master and STOP, user needs to configure I2C slave address to I2CID (0x01) [7:1]. To start I2C read transfer, I2CCLT (0x07) is configured to 0xf9 (1111 1001). I2C Master will launch START, Slave address, Read bit, and load ACK to I2CMST (0x02) [2], load data to I2CDR, reply ACK and then STOP sequentially.

For I2C read transfer whose data are more than 1 byte, user could split the cycles according to I2C protocol.

7.3.5 I2C and SPI Usage

I2C hardware and SPI hardware modules in the chip share part of the hardware, as a result, when both hardware interfaces are used, the restrictions listed within this section need to be taken into consideration.

I2C and SPI hardware cannot be used as Slave at the same time.

The other cases are supported, including:

- ✧ I2C and SPI can be used as Master at the same time.
- ✧ I2C Master and SPI Slave can be used at the same time.
- ✧ I2C Slave and SPI Master can be used at the same time.

7.4 SPI

The TLSR8367 embeds SPI (Serial Peripheral interface), which could act as Master mode or Slave mode. SPI is a high-speed, full-duplex and synchronous communication bus requiring 4 bus lines including a chip select (CS) line, a data input (DI) line, a data output (DO) line and a clock (CK) line.

Register SPICT (address 0x09) bit[1] and bit[6] serve to select SPI Master mode or Slave mode. By default, 0x09 bit[1] is set as 1b'0 and bit[6] is set as 1b'1, therefore SPI acts as Slave mode by default.

7.4.1 Register table

Table 7- 5 Register configuration for SPI

Address	Name	R/W	Description	Reset Value
0x08	SPIDAT	RW	SPI data access	00
0x09	SPICT	RW	[0]: p_csn [1]: enable SPI master mode (1) [2]: spi data output disable [3]: 1 for read command; 0 for write command [4]: address auto increase [5]: share_mode [6]: enable SPI slave mode (1) [7]: busy status	51
0x0a	SPISP	RW	[6:0]: SPI clock speed [7]: SPI function mode, p_csn, p_scl, p_sda and p_sdo function as SPI if 1	05
0x0b	SPIMODE	RW	[0]: inverse SPI clock output [1]: delay half clk for SPI data output	00

7.4.2 SPI Master mode

Address 0x09 bit[1] should be set as 1b'1 to enable SPI Master mode.

Register SPISP (address 0x0a) serves to configure SPI pin and clock: setting 0x0a bit[7] as 1b'1 is to enable SPI function mode, and corresponding pins can be used as SPI pins; SPI clock = system clock/((clock speed configured in address 0x0a bit[6:0] +1)*2).

SPIDAT (address 0x08) serves as the data register. One reading/writing operation of 0x08 enables the SPI_CLK pin to generate 8 SPI clock cycles.

Telink SPI supports four standard working modes: Mode 0~Mode 3. Register SPIMODE (address 0x0b) serves to select one of the four SPI modes:

Table 7- 6 SPI Master mode

SPI mode	CPOL/CPHA	SPIMODE register (Address 0x0b)
Mode 0	CPOL=0, CPHA=0	bit[0]=0, bit[1]=0
Mode 1	CPOL=0, CPHA=1	bit[0]=0, bit[1]=1
Mode 2	CPOL=1, CPHA=0	bit[0]=1, bit[1]=0
Mode 3	CPOL=1, CPHA=1	bit[0]=1, bit[1]=1

CPOL: Clock Polarity
 When CPOL=0, SPI_CLK keeps low level in idle state;
 When CPOL=1, SPI_CLK keeps high level in idle state.
 CPHA: Clock Phase
 When CPHA=0, data is sampled at the first edge of clock period
 When CPHA=1, data is sampled at the latter edge of clock period

Address 0x09 bit[0] serves to control the CS line: when the bit is set to 1, the CS level is high; when the bit is cleared, the CS level is low.

Address 0x09 bit[2] is the disabling bit for SPI Master output. When the bit is cleared, MCU writes data into address 0x08, then the SPI_DO pin outputs the data bit by bit during the 8 clock cycles generated by the SPI_CLK pin. When the bit is set to 1b'1, SPI_DO output is disabled.

Address 0x09 bit[3] is the enabling bit for SPI Master reading data function. When the bit is set to 1b'1, MCU reads the data from address 0x08, then the input data from the SPI_DI pin is shifted into address 0x08 during the 8 clock cycles generated by the SPI_CLK pin. When the bit is cleared, SPI Master reading function is disabled.

Address 0x09[5] is the enabling bit for share mode, i.e. whether SPI_DI and SPI_DO share one common line.

Users can read address 0x09 bit[7] to get SPI busy status, i.e. whether the 8 clock pulses have been sent.

7.4.3 SPI Slave mode

SPI for the TLSR8367 acts as Slave mode by default. (Address 0x09 bit[6] should be set as 1b'1 to enable SPI Slave mode.)

SPI Slave mode supports DMA. User could access registers of the TLSR8367 by SPI interface. It's noted that system clock of TLSR8367 shall be at least 5x faster than SPI clock for reliable connection. Address 0x0a should be written with data 0xa5 by the SPI host to activate SPI Slave mode. SPI slave only supports Mode0 and Mode3.

Table 7- 7 SPI Slave mode

SPI slave mode	CPOL/CPHA
Mode 0	CPOL=0, CPHA=0
Mode 3	CPOL=1, CPHA=1
Receive data at positive edge of SPI MCLK clock. Send data at negative edge of SPI MCLK clock.	

Address 0x09[4] is dedicated for SPI Slave mode and indicates address auto increment. SPI write command format and read command format are illustrated in Figure 7-8:

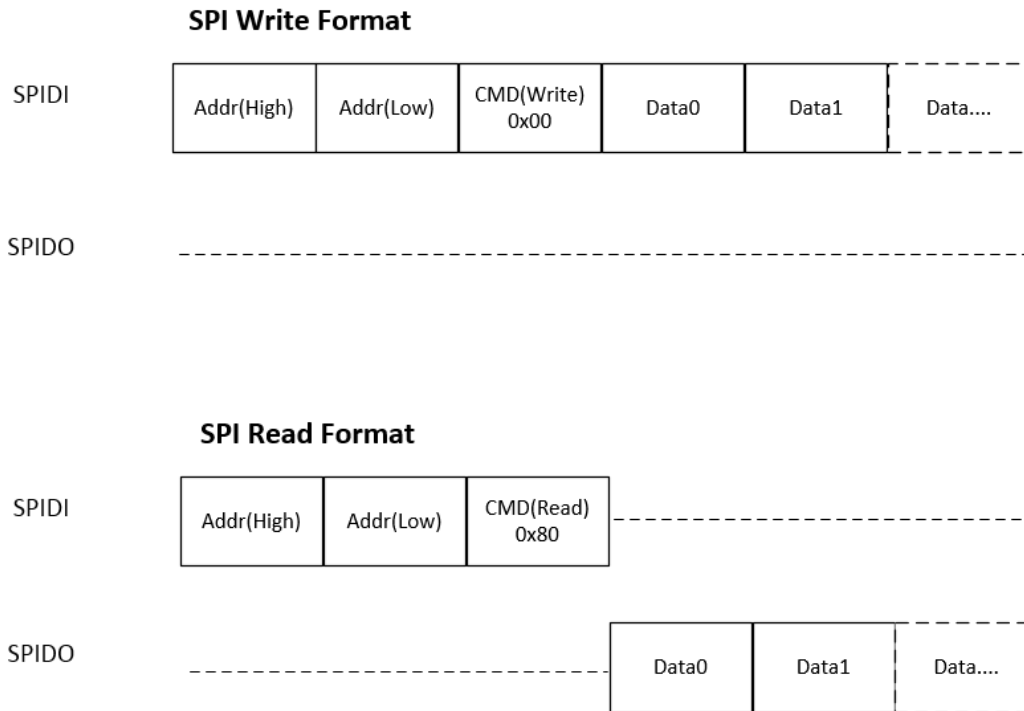

Figure 7- 8 SPI write/read command format

7.4.4 I2C and SPI Usage

I2C hardware and SPI hardware modules in the chip share part of the hardware, as a result, when both hardware interfaces are used, certain restrictions apply. See **Section 7.3.5 I2C and SPI Usage** for detailed instructions.

7.5 UART

The TLSR8367 embeds UART (Universal Asynchronous Receiver/Transmitter) to implement full-duplex transmission and reception via UART TX and RX interface. Both TX and RX interface are 4-layer FIFO (First In First Out) interface.

Hardware flow control is supported via RTS and CTS.

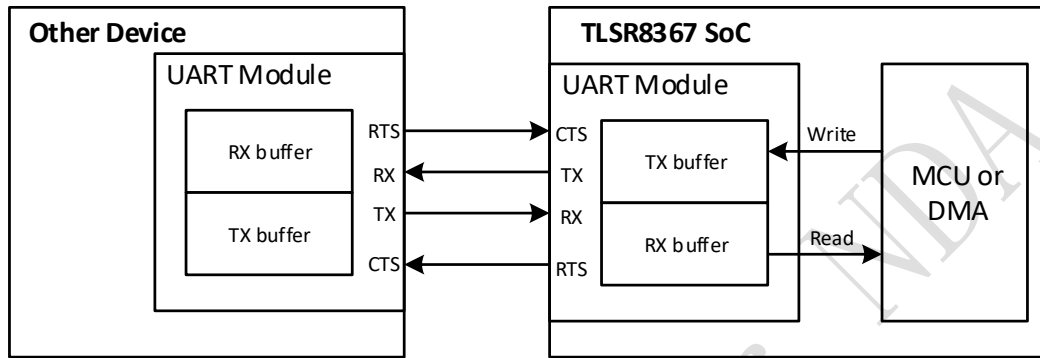

Figure 7-9 UART communication

As shown in Figure 7-9, data to be sent is first written into TX buffer by MCU or DMA, then UART module transmits the data from TX buffer to other device via pin TX. Data to be read from other device is first received via pin RX and sent to RX buffer, then the data is read by MCU or DMA.

If RX buffer of the TLSR8367 UART is close to full, the TLSR8367 will send a signal (configurable high or low level) via pin RTS to inform other device that it should stop sending data. Similarly, if the TLSR8367 receives a signal from pin CTS, it indicates that RX buffer of other device is close to full and the TLSR8367 should stop sending data.

Table 7-8 Register configuration for UART

Address	Name	R/W	Description	Reset Value
0x90	uart_data_buf0	R/W	write/read buffer[7:0]	*No power on reset
0x91	Uart_data_buf1	R/W	Write/read buffer[15:8]	
0x92	Uart_data_buf2	RW	Write/read buffer[23:16]	
0x93	Uart_data_buf3	R/W	Write/read buffer[31:24]	
0x94	uart_clk_div[7:0]	RW	uart clk div register:	0xff
0x95	Uart_clk_div[15:8]	R/W	uart_sclk = sclk/(uart_clk_div[14:0]+1) uart_clk_div[15] : 1: enable clock divider, 0: disable.	0x0f
0x96	Uart ctrl0	R/W	[3:0] bwpc, bit width, should be larger than 2 Baudrate = uart_sclk/(bwpc+1) [4] rx dma enable [5] tx dma enable [6] rx interrupt enable [7]tx interrupt enable	0x0f
0x97	Uart_ctrl1	R/W	[0] cts select, 0: cts_i, 1: cts_i inverter	0x0e

Address	Name	R/W	Description	Reset Value
			[1]:cts enable, 1: enable, 0, disable [2]:Parity, 1: enable, 0 :disable [3]: even Parity or odd [5:4]: stop bit 00: 1 bit, 01: 1.5bit, 1x: 2bits [6]: ttl [7]: uart tx, rx loopback	
0x98	Uart_ctrl2	R/W	[3:0] rts trig level [4] rts Parity [5] rts manual value [6] rts manual enable [7] rts enable	0xa5
0x99	Uart_ctrl3	R/W	[3:0]: rx_irq_trig level [7:4] tx_irq_trig level	0x44
0x9a	R_rxttimeout_o[7:0]	R/W	The setting is transfer one bytes need cycles base on uart_clk. For example, if transfer one bytes (1 start bit+8bits data+1 priority bit+2 stop bits) total 12 bits, this register setting should be $(bwpc+1)*12$.	0x0f
0x9b	R_rxttimeout_o[9:8]	R/W	2'b00:rx timeout time is r_rxttimeout[7:0] 2'b01:rx timeout time is r_rxttimeout[7:0]*2 2'b10:rx timeout time is r_rxttimeout[7:0]*3 3'b11: rx timeout time is r_rxttimeout[7:0]*4 R_rxttimeout is for rx dma to decide the end of each transaction. Supposed the interval between each byte in one transaction is very short.	0x00
0x9c	Buf_cnt	R	[3:0]: r_buf_cnt [7:4]: t_buf_cnt	0x00
0x9d	Uart_sts	R	[2:0] rbcnt [3] irq [6:4]wbcnt [6] write 1 clear rx [7] rx_err, write 1 clear tx	0x00

***Note:** Addresses 0x90~0x93 won't be reset after power on.

Addresses 0x90~0x93 serve to write data into TX buffer or read data from RX buffer.

Addresses 0x94~0x95 serve to configure UART clock.

Address 0x96 serves to set baud rate (bit[3:0]), enable RX/TX DMA mode (bit[4:5]), and enable RX/TX interrupt (bit[6:7]).

Address 0x97 mainly serves to configure CTS. Bit[1] should be set to 1b'1 to enable CTS. Bit[0] serves to configure CTS signal level. Bit[2:3] serve to enable parity bit and select even/odd parity. Bit[5:4] serve to select 1/1.5/2 bits for stop bit. Bit[6] serves to configure whether RX/TX level should be inverted.

Address 0x98 serves to configure RTS. Bit[7] and Bit[3:0] serve to enable RTS and configure RTS signal level.

Address 0x99 serves to configure the number of bytes in RX/TX buffer to trigger interrupt.

The number of bytes in RX/TX buffer can be read from address 0x9c.

8 PWM

The TLSR8367 supports 5-channel PWM (Pulse-Width-Modulation) output. Each PWM#n (n=0~4) has its corresponding inverted output at PWM#n_N pin.

8.1 Register table

Table 1 Register table for PWM

Address	Mnemonic	Type	Description	Reset Value
0x780	PWM_EN0	R/W	[0]: Rsvd [1:4]: Enable/Disable PWM1~PWM4 0--disable, 1--enable	0x00
0x781	PWM_EN1	R/W	[0]: Enable/Disable PWM0 0--disable, 1--enable	0x00
0x782	PWM_CLK	R/W	(PWM_CLK+1)*sys_clk	0x00
0x783	PWM_MODE	R/W	[3:0]: PWM0 mode select 0000-pwm0 normal mode 0001-pwm0 count mode 0011-pwm0 IR mode 0111-pwm0 IR FIFO mode 1111-pwm0 IR DMA FIFO mode	0x00
0x784	PWM_CC0	R/W	[4:0]:1'b1 invert PWM4~PWM0 output	0x00
0x785	PWM_CC1	R/W	[4:0]:1'b1 invert PWM4_INV~PWM0_INV output	0x00
0x786	PWM_CC2	R/W	[4:0]: Signal frame polarity of PWM4~PWM0 1b'0-high level first 1b'1-low level first	0x00
0x787	PWM_32K_MODE	R/W	[0:4]: Set clock mode for PWM0~PWM4 1-- use pwm_32clk 0-- use pwm_sysclk	0x00
0x788~ 0x793	reserved			
0x794	PWM_TCMPO	R/W	[7:0] bits 7-0 of PWM0's high time or low time(if pola[0]=1)	0x00
0x795	PWM_TCMPO	R/W	[15:8] bits 15-8 of PWM0's high time or low time	0x00
0x796	PWM_TMAX0	R/W	[7:0] bits 7-0 of PWM0's cycle time	0x00
0x797	PWM_TMAX0	R/W	[15:8] bits 15-8 of PWM0's cycle time	0x00
0x798	PWM_TCMP1	R/W	[7:0] bits 7-0 of PWM1's high time or low time(if pola[1]=1)	0x00
0x799	PWM_TCMP1	R/W	[15:8] bits 15-8 of PWM1's high time or low time	0x00

Address	Mnemonic	Type	Description	Reset Value
0x79a	PWM_TMAX1	R/W	[7:0] bits 7-0 of PWM1's cycle time	0x00
0x79b	PWM_TMAX1	R/W	[15:8] bits 15-8 of PWM1's cycle time	0x00
0x79c	PWM_TCMP2	R/W	[7:0] bits 7-0 of PWM2's high time or low time (if pola[2]=1)	0x00
0x79d	PWM_TCMP2	R/W	[15:8] bits 15-8 of PWM2's high time or low time	0x00
0x79e	PWM_TMAX2	R/W	[7:0] bits 7-0 of PWM2's cycle time	0x00
0x79f	PWM_TMAX2	R/W	[15:8] bits 15-8 of PWM2's cycle time	0x00
0x7a0	PWM_TCMP3	R/W	[7:0] bits 7-0 of PWM3's high time or low time (if pola[3]=1)	0x00
0x7a1	PWM_TCMP3	R/W	[15:8] bits 15-8 of PWM3's high time or low time	0x00
0x7a2	PWM_TMAX3	R/W	[7:0] bits 7-0 of PWM3's cycle time	0x00
0x7a3	PWM_TMAX3	R/W	[15:8] bits 15-8 of PWM3's cycle time	0x00
0x7a4	PWM_TCMP4	R/W	[7:0] bits 7-0 of PWM4's high time or low time (if pola[4]=1)	0x00
0x7a5	PWM_TCMP4	R/W	[15:8] bits 15-8 of PWM4's high time or low time	0x00
0x7a6	PWM_TMAX4	R/W	[7:0] bits 7-0 of PWM4's cycle time	0x00
0x7a7	PWM_TMAX4	R/W	[15:8] bits 15-8 of PWM4's cycle time	0x00
0x7ac	PWM_PNUM0	R/W	[7:0]PWM0 Pulse number in count mode and IR mode	0x00
0x7ad	PWM_PNUM0	R/W	[13:8]	0x00
0x7ae~ 0x7af	reserved			
0x7b0	PWM_MASK0	R/W	INT mask [0] PWM0 Pnum int 0: disable 1: Enable [1] PWM0 ir dma fifo mode int 0: disable 1: Enable [2:6] PWM0~PWM4 frame int 0: disable, 1: enable	0x00
0x7b1	PWM_INT0	R/W	INT status, write 1 to clear [0]: PWM0 pnum int (have sent PNUM pulses, PWM_NCNT==PWM_PNUM) [1]: PWM0 ir dma fifo mode int (pnum int & fifo empty in ir dma fifo mode) [2:6]: PWM0~PWM4 cycle done int (PWM_CNT==PWM_TMAX)	0x00
0x7b2	PWM_MASK1	R/W	[0]: PWM0 fifo mode fifo cnt int	0x00

Address	Mnemonic	Type	Description	Reset Value
			mask 0: disable, 1: enable	
0x7b3	PWM_INT1	R/W	INT status, write 1 to clear [0]: fifo mode cnt int, when FIFO_NUM (0x7cd[3:0]) is less than FIFO_NUM_LVL (0x7cc[3:0])	0x00
0x7b4	PWM_CNT0	R	[7:0]PWM0 cnt value	0x00
0x7b5	PWM_CNT0		[15:8]PWM0 cnt value	0x00
0x7b6	PWM_CNT1	R	[7:0]PWM1 cnt value	0x00
0x7b7	PWM_CNT1		[15:8]PWM1 cnt value	0x00
0x7b8	PWM_CNT2	R	[7:0]PWM2 cnt value	0x00
0x7b9	PWM_CNT2		[15:8]PWM2 cnt value	0x00
0x7ba	PWM_CNT3	R	[7:0]PWM3 cnt value	0x00
0x7bb	PWM_CNT3		[15:8]PWM3 cnt value	0x00
0x7bc	PWM_CNT4	R	[7:0]PWM4 cnt value	0x00
0x7bd	PWM_CNT4		[15:8]PWM4 cnt value	0x00
0x7c0	PWM_NCNT0	R	[7:0]PWM0 pluse_cnt value	0x00
0x7c1	PWM_NCNT0		[15:8]PWM0 pluse_cnt value	0x00
0x7c4	PWM_TCMPO_SHADOW	R/W	[7:0] bits 7-0 of PWM0's high time or low time(if pola[0]=1), if shadow bit(fifo data[14]) is 1'b1 in ir fifo mode or dma fifo mode	0x55
0x7c5	PWM_TCMPO_SHADOW	R/W	[15:8] bits 15-8 of PWM0's high time or low time, if shadow bit(fifo data[14]) is 1'b1 in ir fifo mode or dma fifo mode	0x55
0x7c6	PWM_TMAX0_SHADOW	R/W	[7:0] bits 7-0 of PWM0's cycle time, if shadow bit(fifo data[14]) is 1'b1 in ir fifo mode or dma fifo mode	0x00
0x7c7	PWM_TMAX0_SHADOW	R/W	[15:8] bits 15-8 of PWM0's cycle time, if shadow bit(fifo frame[14]) is 1'b1 in ir fifo mode or dma fifo mode	0x00
0x7c8	FIFO_DAT0_ENTRY	W	Use in ir fifo mode	
0x7c9	FIFO_DAT1_ENTRY	W	Use in ir fifo mode	
0x7ca	FIFO_DAT2_ENTRY	W	Use in ir fifo mode	
0x7cb	FIFO_DAT3_ENTRY	W	Use in ir fifo mode	
0x7cc	FIFO_NUM_LVL	R/W	FIFO num int trigger level	0x00
0x7cd	FIFO_SR	R	[3:0]:FIFO DATA NUM(byte) [4]:FIFO EMPTY [5]:FIFO FULL	0x00
0x7ce	FIFO_CLR	W1	[0]: write 1 to clear data in FIFO	0x00

8.2 Enable PWM

Register PWM_EN0 (address 0x780[4:1]) and PWM_EN1 (address 0x781[0]) serve to enable PWM4~PWM0 respectively via writing “1” for the corresponding bits.

Shared under NDA

8.3 Set PWM clock

PWM clock derives from system clock. Register PWM_CLK (address 0x782) serves to set the frequency dividing factor for PWM clock. Formula below applies:

$$F_{\text{PWM}} = F_{\text{System clock}} / (\text{PWM_CLK} + 1)$$

8.4 PWM waveform, polarity and output inversion

Each PWM channel has independent counter and 2 status including “Count” and “Remaining”. Count and Remaining status form a signal frame.

8.4.1 Waveform of signal frame

When PWM#n is enabled, first PWM#n enters Count status and outputs High level signal by default. When PWM#n counter reaches cycles set in register PWM_TCMP#n (address 0x794~0x795, 0x798~0x799, 0x79c~0x79d, 0x7a0~0x7a1, 0x7a4~0x7a5) / PWM_TCMP0_SHADOW (0x7c4~0x7c5), PWM#n enters Remaining status and outputs Low level till PWM#n cycle time configured in register PWM_TMAX#n (address 0x796~0x797, 0x79a~0x79b, 0x79e~0x79f, 0x7a2~0x7a3, 0x7a6~0x7a7) / PWM_TMAX0_SHADOW (0x7c6~0x7c7) expires.

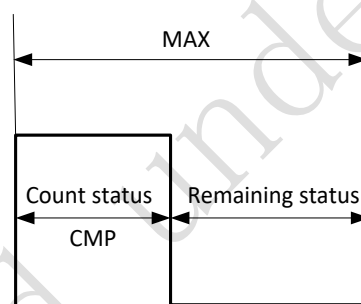

Figure 8- 1 A signal frame

An interruption will be generated at the end of each signal frame if enabled via register PWM_MASK0 (address 0x7b0[2:6]).

8.4.2 Invert PWM output

PWM#n and PWM#n_N output could be inverted independently via register PWM_CC0 (address 0x784) and PWM_CC1 (address 0x785). When the inversion bit is enabled, waveform of the corresponding PWM channel will be inverted completely.

8.4.3 Polarity for signal frame

By default, PWM#n outputs High level at Count status and Low level at Remaining status. When the corresponding polarity bit is enabled via register PWM_CC2 (address 0x786[4:0]), PWM#n will output Low level at Count status and High level at Remaining status.

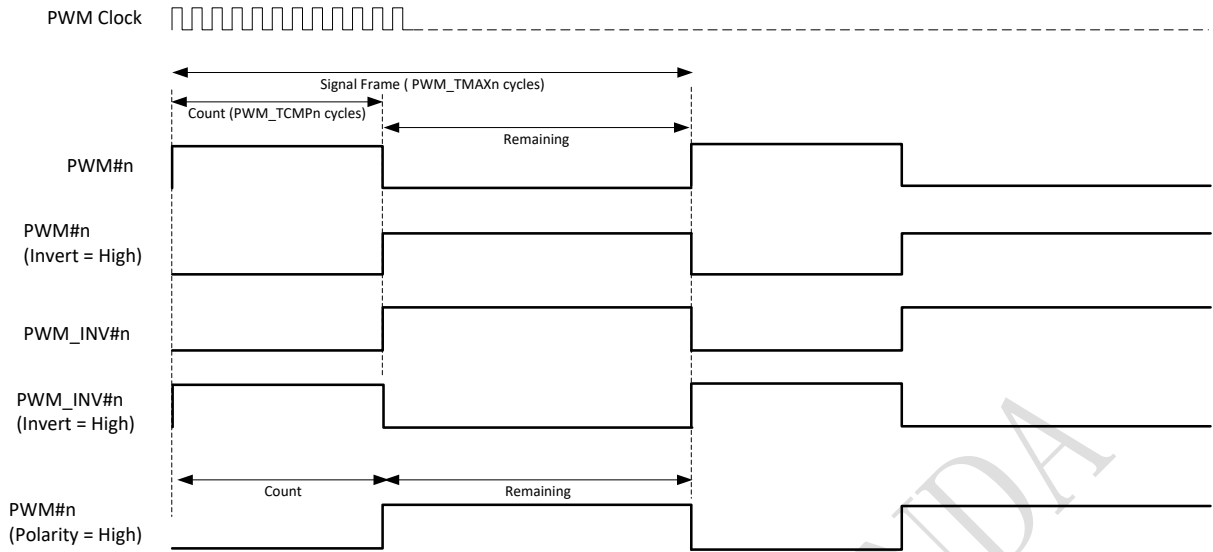

Figure 8-2 PWM output waveform chart

8.5 PWM mode

8.5.1 Select PWM mode

PWM0 supports five modes, including Continuous mode (normal mode, default), Counting mode, IR mode, IR FIFO mode, IR DMA FIFO mode.

PWM1~PWM4 only support Continuous mode.

Register PWM_MODE (address 0x783) serves to select PWM0 mode.

8.5.2 Continuous mode

PWM0~PWM4 all support Continuous mode. In this mode, PWM#n continuously sends out signal frames. PWM#n should be disabled via address 0x780 or 0x781 to stop it; when stopped, the PWM output will turn low immediately.

During Continuous mode, waveform could be changed freely via PWM_TCMP#n and PWM_TMAX#n. New configuration for PWM_TCMP#n and PWM_TMAX#n will take effect in the next signal frame.

After each signal frame is finished, corresponding PWM cycle done interrupt flag bit (0x7b1[2:6]) will be automatically set to 1b'1. If the interrupt is enabled by setting PWM_MASK0 (address 0x7b0[2:6]) as 1b'1, a frame interruption will be generated. User needs to write 1b'1 to the flag bit to manually clear it.

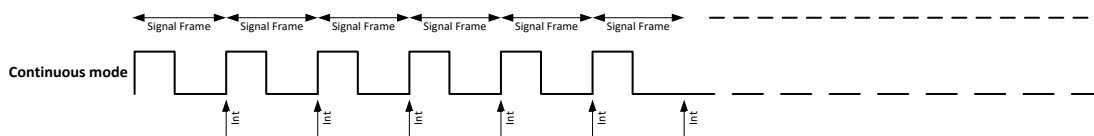

Figure 8-3 Continuous mode

8.5.2.1 Set PWM clock mode

In continuous mode, by default PWM0~PWM4 use the system clock mode. To enable PWM to generate waveforms in suspend state, the 32kHz clock mode can be enabled via the configuration sequence below.

- 1) Disable PWM clock (0x64[4]=0), and enable PWM reset (0x61[4]=1).
- 2) Set 0x787[0]~[4] as 1b'1 to switch base clock to 32kHz for PWM0~PWM4.
- 3) Enable PWM clock (0x64[4]=1) and PWM_32kHz clock (0x65[1]=1), disable PWM reset (0x61[4]=0).

Then corresponding PWM can work normally even in 32kHz clock.

8.5.3 Counting mode

Only PWM0 supports Counting mode. Address 0x783[3:0] should be set as 4b'0001 to select PWM0 counting mode.

In this mode, PWM0 sends out specified number of signal frames which is defined as a pulse group. The number is configured via register PWM_PNUM0 (address 0x7ac~0x7ad).

After each signal frame is finished, PWM0 cycle done interrupt flag bit (0x7b1[2]) will be automatically set to 1b'1. If the interrupt is enabled by setting PWM_MASK0 (address 0x7b0[2]) as 1b'1, a frame interruption will be generated. User needs to write 1b'1 to the flag bit to manually clear it.

After a pulse group is finished, PWM0 will be disabled automatically, and PWM0 pnum interrupt flag bit (0x7b1[0]) will be automatically set to 1b'1. If the interrupt is enabled by setting PWM_MASK0 (address 0x7b0[0]) as 1b'1, a Pnum interruption will be generated. User needs to write 1b'1 to the flag bit to manually clear it.

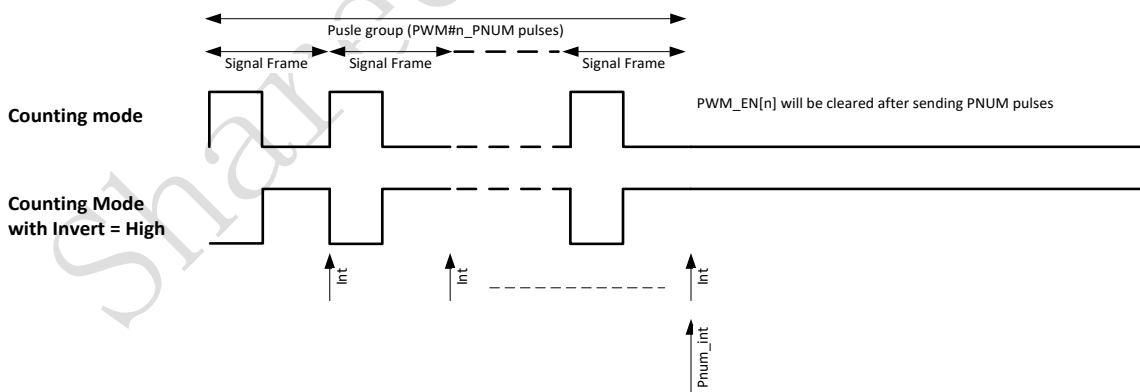

Figure 8-4 Counting mode (n=0)

Counting mode also serves to stop IR mode gracefully. Refer to [Section 8.5.4](#) for details.

8.5.4 IR mode

Only PWM0 supports IR mode. Address 0x783[3:0] should be set as 4b'0011 to select PWM0 IR mode.

In this mode, specified number of frames is defined as one pulse group. In contrast to Counting mode where PWM0 stops after first pulse group is finished, PWM0 will constantly send pulse groups in IR mode.

During IR mode, PWM0 output waveform could also be changed freely via WM_TCMPO, PWM_TMAX0 and PWM_PNUM0. New configuration for PWM_TCMPO, PWM_TMAX0 and PWM_PNUM0 will take effect in the next pulse group.

To stop IR mode and complete current pulse group, user can switch PWM0 from IR mode to Counting mode so that PWM0 will stop after current pulse group is finished. If PWM0 is disabled directly via PWM_EN1 (0x781[0]), PWM0 output will turn Low immediately despite of current pulse group.

After each signal frame/pulse group is finished, PWM0 cycle done interrupt flag bit (0x7b1[2])/PWM0 pnum interrupt flag bit (0x7b1[0]) will be automatically set to 1b'1. A frame interruption/Pnum interruption will be generated (if enabled by setting address 0x7b0[2]/0x7b0[0] as 1b'1).

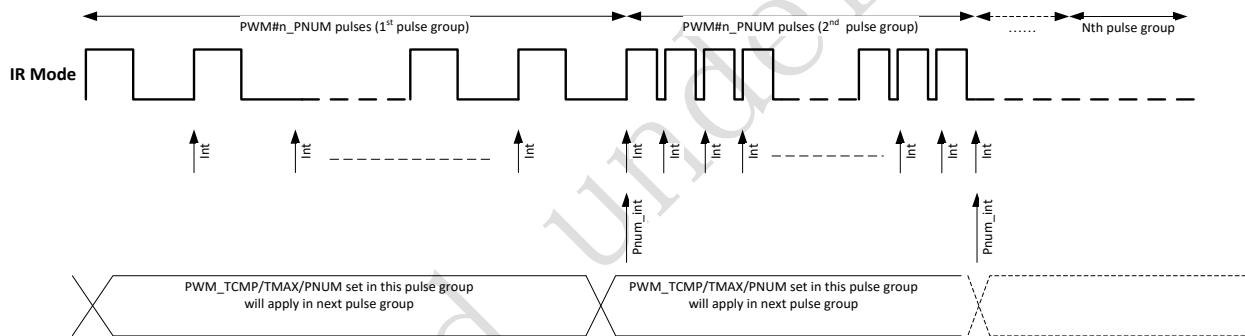

Figure 8-5 IR mode (n=0)

8.5.5 IR FIFO mode

IR FIFO mode is designed to allow IR transmission of long code patterns without the continued intervention of MCU, and it is designed as a selectable working mode on PWM0. The IR carrier frequency is divided down from the system clock and can be configured as any normal IR frequencies, e.g. 36kHz, 38kHz, 40kHz, or 56kHz.

Only PWM0 supports IR FIFO mode. Address 0x783[3:0] should be set as 4b'0111 to select PWM0 IR FIFO mode.

An element ("FIFO CFG Data") is defined as basic unit of IR waveform, and written into FIFO. This element consists of 16 bits, including:

- ◇ bit[13:0] defines PWM pulse number of current group.
- ◇ bit[14] determines duty cycle and period for current PWM pulse group.

0: use configuration of TCMPO and TMAX0 in 0x794~0x797;

1: use configuration of TCMPO_SHADOW and TMAX0_SHADOW in 0x7c4~0x7c7.

◇ bit[15] determines whether current PWM pulse group is used as carrier, i.e. whether PWM will output pulse (1) or low level (0).

User should use FIFO_DATA_ENTRY in 0x7c8~0x7cb to write the 16-bit “FIFO CFG Data” into FIFO by byte or half word or word.

- ◇ To write by byte, user should successively write 0x7c8, 0x7c9, 0x7ca and 0x7cb.
- ◇ To write by half word, user should successively write 0x7c8 and 0x7ca.
- ◇ To write by word, user should write 0x7c8.

FIFO depth is 8 bytes. User can read the register FIFO_SR in 0x7cd to view FIFO empty/full status and check FIFO data number.

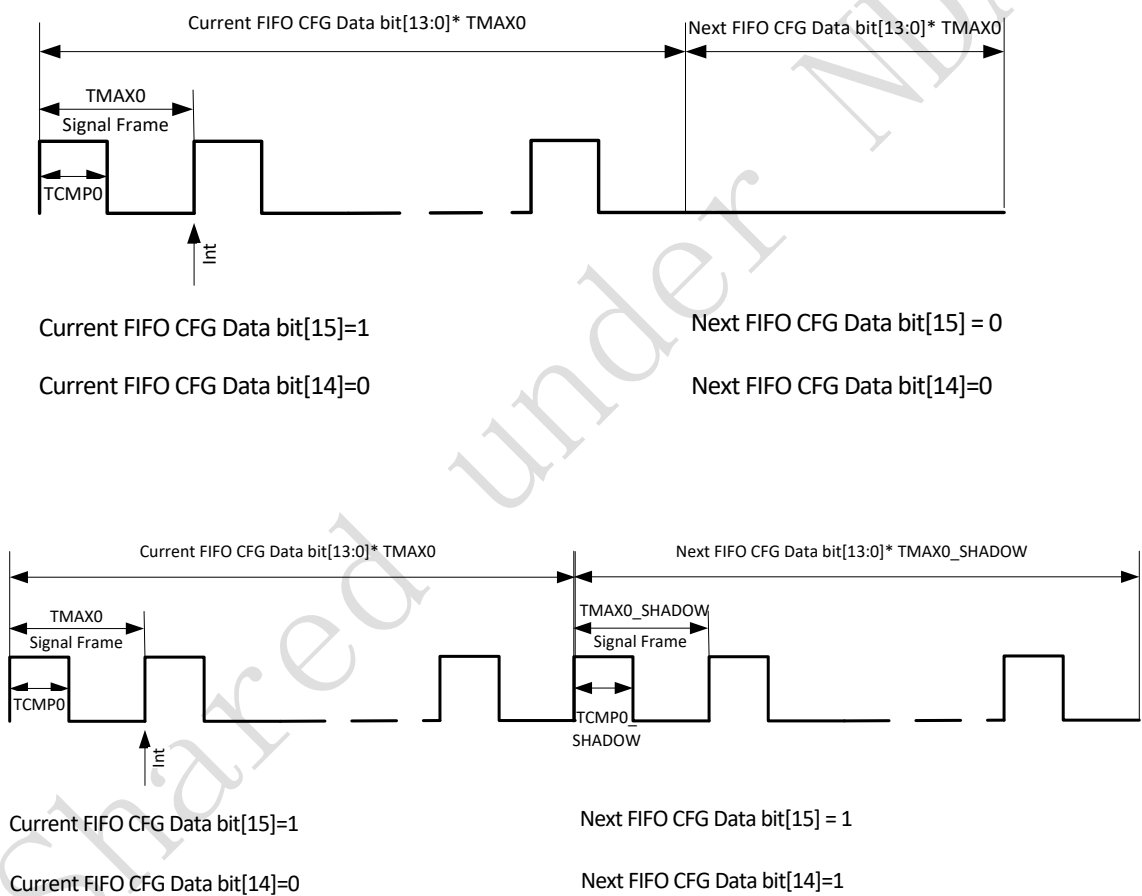

Figure 8- 6 IR format examples

When “FIFO CFG Data” is configured in FIFO and PWM0 is enabled via PWM_EN1 (address 0x781[0]), the configured waveforms will be output from PWM0 in sequence. As long as FIFO doesn’t overflow, user can continue to add waveforms during IR waveforms sending process, and long IR code that exceeds the FIFO depth can be implemented this way. After all waveforms are sent, FIFO becomes empty, PWM0 will be disabled automatically.

The FIFO_CLR register (address 0x7ce[0]) serves to clear data in FIFO. Writing 1b'1 to this register will clear all data in the FIFO. Note that the FIFO can only be cleared when not in active transmission.

8.5.6 IR DMA FIFO mode

IR DMA FIFO mode is designed to allow IR transmission of long code patterns without occupation of MCU, and it is designed as a selectable working mode on PWM0. The IR carrier frequency is divided down from the system clock and can be configured as any normal IR frequencies, e.g. 36kHz, 38kHz, 40kHz, or 56kHz.

Only PWM0 supports IR DMA FIFO mode. Address 0x783[3:0] should be set as 4b'1111 to select PWM0 IR DMA FIFO mode.

This mode is similar to IR FIFO mode, except that "FIFO CFG Data" is written into FIFO by DMA instead of MCU. User should write the configuration of "FIFO CFG Data" into RAM, and then enable DMA channel 5. DMA will automatically write the configuration into FIFO.

***Note:** In this mode, when DMA channel 5 is enabled, PWM will automatically output configured waveform, without the need to manually enable PWM0 via 0x781[0] (i.e. 0x781[0] will be set as 1b'1 automatically).

Example 1:

Suppose Mark carrier (pulse) frequency1(F1) = 40kHz, duty cycle 1/3

Mark carrier (pulse) frequency2(F2) = 50kHz, duty cycle 1/2

Space carrier (low level) frequency(F3) = 40kHz

If user wants to make PWM send waveforms in following format (PWM CLK =24MHz):

Burst(20[F1]), i.e. 20 F1 pulses

Burst(30[F2]),

Burst(50[F1]),

Burst(50[F2]),

Burst(20[F1],10[F3]),

Burst(30[F2],10[F3])

Step1: Set carrier F1 frequency as 40kHz, set duty cycle as 1/3.

Set **PWM_TMAX0** as 0x258 (i.e. $24\text{MHz}/40\text{kHz}=600=0x258$).

Since duty cycle is 1/3, set **PWM_TCMPO** as 0xc8 (i.e. $600/3=200=0xc8$).

Set carrier F2 frequency as 50kHz, set duty cycle as 1/2.

Set **PWM_TMAX0_SHADOW** as 0x1e0 (i.e. $24\text{MHz}/50\text{kHz}=480=0x1e0$).

Since duty cycle is 1/2, set **PWM_TCMPO_SHADOW** as 0xf0 (i.e. $480/2=240=0xf0$).

User can follow the steps below to configure related registers:

Step1: Set carrier frequency as 38kHz, set duty cycle as 1/3.

Set **PWM_TMAX0** as 0x277 (i.e. $24\text{MHz}/38\text{kHz}=631=0x277$).

Since duty cycle is 1/3, set **PWM_TCMPO** as 0xd2 (i.e. $631/3=210=0xd2$).

Step2: Generate “FIFO CFG Data” sequence.

Preamble waveform:

9ms carrier: {[15]:1'b1, [14]:1'b0, [13:0]: $9*38=d\ 342=14'h\ 156$ }=0x8156

4.5ms low level: {[15]:1'b0, [14]:1'b0, [13:0]: $4.5*38=d\ 171=14'h\ ab$ }=0x00ab

Data 1 waveform:

0.56ms carrier: {[15]:1'b1, [14]:1'b0, [13:0]: $0.56*38=d\ 21=14'h\ 15$ }=0x8015

0.56ms low level: {[15]:1'b0, [14]:1'b0, [13:0]: $0.56*38=d\ 21=14'h\ 15$ }=0x0015

Data 0 waveform:

0.56ms carrier: {[15]:1'b1, [14]:1'b0, [13:0]: $0.56*38=d\ 21=14'h\ 15$ }=0x8015

1.69ms low level: {[15]:1'b0, [14]:1'b0, [13:0]: $1.69*38=d\ 64=14'h\ 40$ }=0x0040

Repeat waveform:

9ms carrier: {[15]:1'b1, [14]:1'b0, [13:0]: $9*38=d\ 342=14'h\ 156$ }=0x8156

2.25ms low level: {[15]:1'b0, [14]:1'b0, [13:0]: $2.25*38=d\ 86=14'h\ 56$ }=0x0056

0.56ms carrier: {[15]:1'b1, [14]:1'b0, [13:0]: $0.56*38=d\ 21=14'h\ 15$ }=0x8015

108ms -11.81ms =96.19ms low level:

{[15]:1'b0, [14]:1'b0, [13:0]: $96.19*38=d\ 3655=14'h\ e47$ }=0x0e47

End waveform:

0.56ms carrier: {[15]:1'b1, [14]:1'b0, [13:0]: $0.56*38=d\ 21=14'h\ 15$ }=0x8015

Step3: Write “IR CFG Data” into SRAM in DMA format.

If user want PWM0 to send IR waveform in following format:

Preamble+0x5a+Repeat+End

Preamble: 0x8156, 0x00ab

0x5a=8'b01011010

Data 0: 0x8015, 0x0040

Data 1: 0x8015, 0x0015

Data 0: 0x8015, 0x0040

Data 1: 0x8015, 0x0015

Data 1: 0x8015, 0x0015
 Data 0: 0x8015, 0x0040
 Data 1: 0x8015, 0x0015
 Data 0: 0x8015, 0x0040
 Repeat: 0x8156, 0x0056, 0x8015, 0x0e47
 End: 0x8015.

User needs to write the configuration information above into source address of DMA channel 5, as shown below:

DMA SOURCE ADDRESS+0x00: 0x0000_002e (dma transfer-length: 46byte)
 DMA SOURCE ADDRESS+0x04: 0x00ab_8156 (Preamble) (LITTLE ENDIAN)
 DMA SOURCE ADDRESS+0x08: 0x0040_8015 (Data 0)
 DMA SOURCE ADDRESS+0x0c: 0x0015_8015 (Data 1)
 DMA SOURCE ADDRESS+0x10: 0x0040_8015 (Data 0)
 DMA SOURCE ADDRESS+0x14: 0x0015_8015 (Data 1)
 DMA SOURCE ADDRESS+0x18: 0x0015_8015 (Data 1)
 DMA SOURCE ADDRESS+0x1c: 0x0040_8015 (Data 0)
 DMA SOURCE ADDRESS+0x20: 0x0015_8015 (Data 1)
 DMA SOURCE ADDRESS+0x24: 0x0040_8015 (Data 0)
 DMA SOURCE ADDRESS+0x28: 0x0056_8156 (Repeat)
 DMA SOURCE ADDRESS+0x2c: 0x0e47_8015 (Repeat)
 DMA SOURCE ADDRESS+0x30: 0x8015 (End)

Step4: Enable DMA channel 5 to send PWM waveforms.

Write 1'b1 to address 0x524[5] to enable DMA channel 5.

After all waveforms are sent, FIFO becomes empty, PWM0 will be disabled automatically (address 0x781[0] is automatically cleared). The FIFO mode stop interrupt flag bit (address 0x7b3[0]) will be automatically set as 1b'1. If the interrupt is enabled by setting PWM_MASK1 (address 0x7b2[0]) as 1b'1, a FIFO mode stop interrupt will be generated. User needs to write 1b'1 to the flag bit to manually clear it.

8.6 PWM interrupt

There are 8 interrupt sources from PWM function.

After each signal frame, PWM#n (n=0~4) will generate a frame-done IRQ (Interrupt Request) signal.

In Counting mode and IR mode, PWM0 will generate a Pnum IRQ signal after completing a pulse group.

In IR FIFO mode, PWM0 will generate a FIFO mode count IRQ signal when the FIFO_NUM value is less than the FIFO_NUM_LVL, and will generate a FIFO mode stop IRQ signal after FIFO becomes empty.

In IR DMA FIFO mode, PWM0 will generate an IR waveform send done IRQ signal, after DMA has sent all configuration data, FIFO becomes empty and final waveform is sent.

To enable PWM interrupt, the total enabling bit “irq_pwm” (address 0x641[6], see **section 6 Interrupt**) should be set as 1b'1. To enable various PWM interrupt sources, PWM_MASK0 (address 0x7b0[6:0]) and PWM_MASK1 (address 0x7b2[0]) should be set as 1b'1 correspondingly.

Interrupt status can be cleared via register PWM_INT0 (address 0x7b1[6:0]) and PWM_INT1 (address 0x7b3[0]).

9 Quadrature Decoder

The TLSR8367 embeds one quadrature decoder (QDEC) which is designed mainly for applications such as wheel. The QDEC implements debounce function to filter out jitter on the two phase inputs, and generates smooth square waves for the two phase.

9.1 Input pin selection

The QDEC supports two-phase input; each input is selectable from the 8 pins of PortA, PortB, PortC and PortD via setting address 0xd2[2:0] (for channel a)/0xd3[2:0] (for channel b).

Table 9- 1 Input pin selection

Address 0xd2[2:0]/0xd3[2:0]	Pin
0	PD[1]
1	PD[3]
2	PC[3]
3	PB[3]
4	PB[4]
5	PB[5]
6	PA[0]
7	PA[1]

Note: To use corresponding IO as QDEC input pin, it's needed first to enable GPIO function, enable "IE" (1) and disable "OEN" (1) for this IO.

9.2 Common mode and double accuracy mode

The QDEC embeds an internal hardware counter, which is not connected with bus.

Address 0xd7[0] serves to select common mode or double accuracy mode.

For each wheel rolling step, two pulse edges (rising edge or falling edge) are generated.

If address 0xd7[0] is cleared to select common mode, the QDEC Counter value (real time counting value) is increased/decreased by 1 only when the same rising/falling edges are detected from the two phase signals.

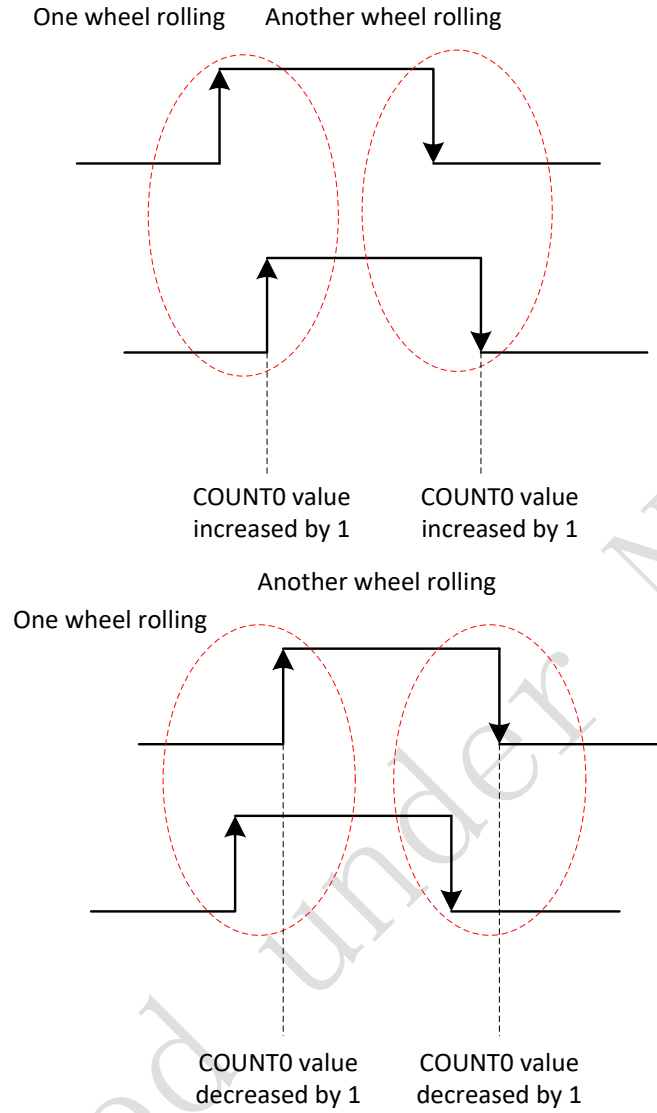

Figure 9- 1 Common mode

If address 0xd7[0] is set to 1b'1 to select double accuracy mode, the QDEC Counter value (real time counting value) is increased/decreased by 1 on each rising/falling edge of the two phase signals; the COUNT0 will be increased/decreased by 2 for one wheel rolling.

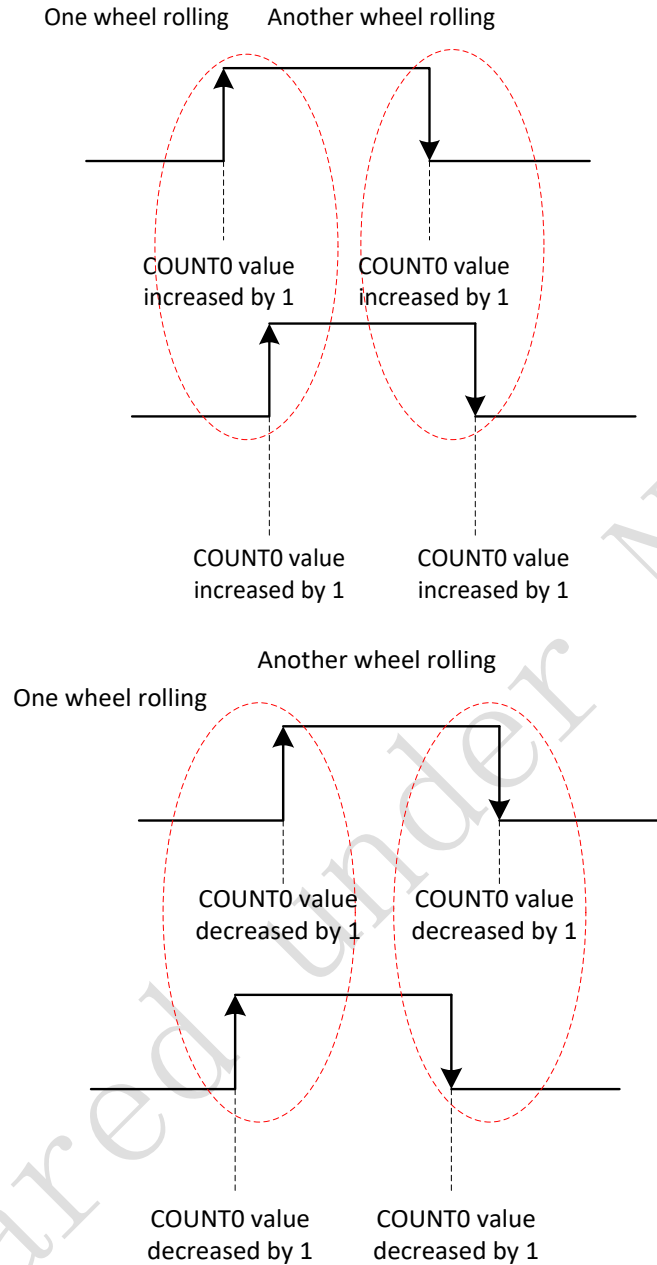

Figure 9- 2 Double accuracy mode

9.3 Read real time counting value

Neither can Hardware Counter value be read directly via software, nor can the counting value in address 0xd0 be updated automatically.

To read real time counting value, first write address 0xd8[0] with 1b'1 to load Hardware Counter data into the QDEC_COUNT register, then read address 0xd0.

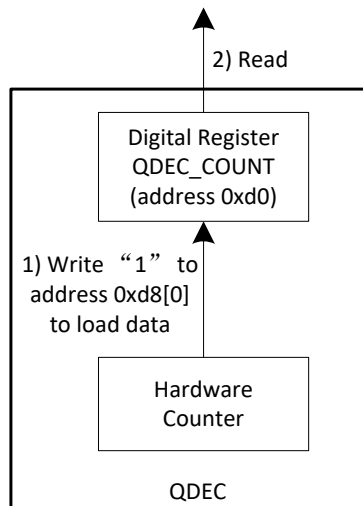

Figure 9-3 Read real time counting value

9.4 QDEC reset

Address 0xd6[0] serves to reset the QDEC. The QDEC Counter value is cleared to zero.

9.5 Other configuration

The QDEC supports hardware debouncing. Address 0xd1[2:0] serves to set filtering window duration. All jitter with period less than the value will be filtered out and thus does not trigger count change.

Address 0xd1[4] serves to set input signal initial polarity.

Address 0xd1[5] serves to enable shuttle mode. Shuttle mode allows non-overlapping two phase signals as shown below.

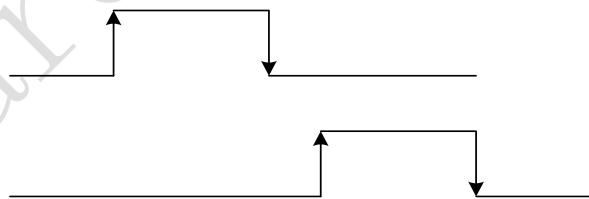

Figure 9-4 Shuttle mode

9.6 Timing sequence

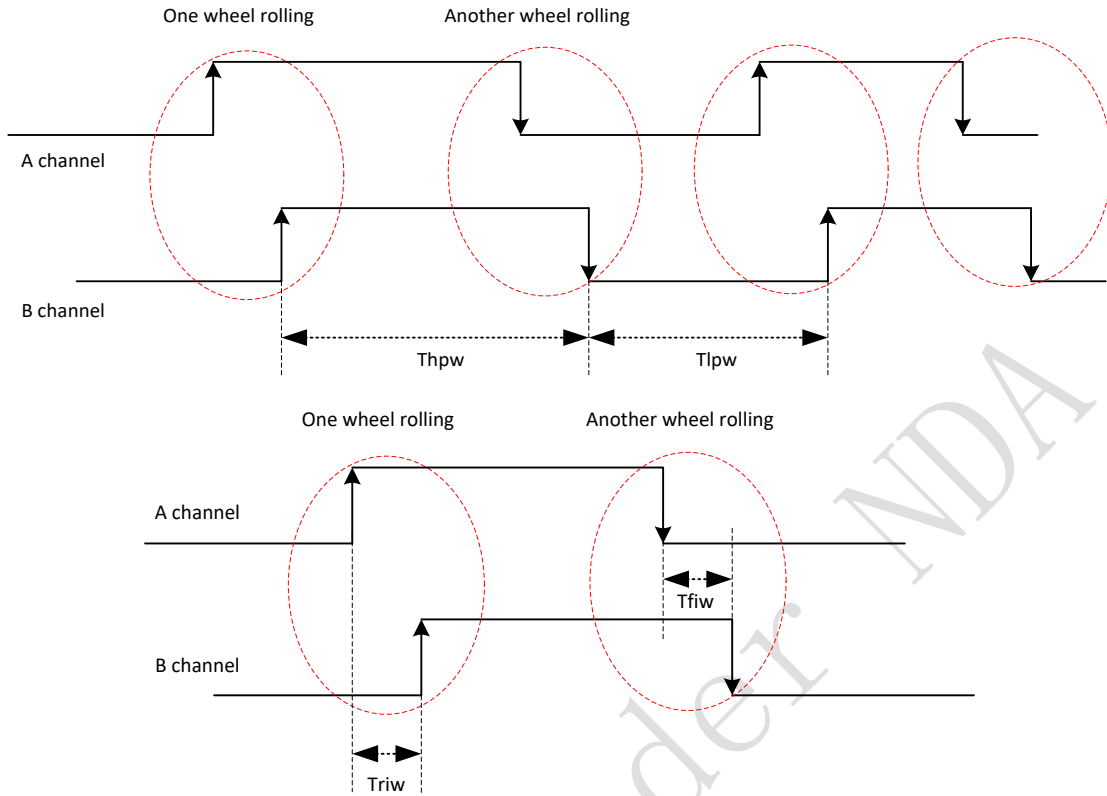

Figure 9- 5 Timing sequence chart

Table 9- 2 Timing

Time interval	Min Value
Thpw (High-level pulse width)	$2^{(n+1)} * \text{clk_32kHz} * 3$ (n=0xd1[2:0])
Tlpw (Low-level pulse width)	$2^{(n+1)} * \text{clk_32kHz} * 3$ (n=0xd1[2:0])
Triw (Interval width between two rising edges)	$2^{(n+1)} * \text{clk_32kHz}$ (n=0xd1[2:0])
Tfiw (Interval width between two falling edges)	$2^{(n+1)} * \text{clk_32kHz}$ (n=0xd1[2:0])

QDEC module works based on 32kHz clock to ensure it can work in suspend mode. QDEC module supports debouncing function, and any signal with width lower than the threshold (i.e. $2^{(n+1)} * \text{clk_32kHz} * 3$ (n=0xd1[2:0])) will be regarded as jitter. Therefore, effective signals input from Channel A and B should contain high/low level with width Thpw/Tlpw more than the threshold. The $2^n * \text{clk_32kHz}$ clock is used to synchronize input signal of QDEC module, so the interval between two adjacent rising/falling edges from Channel A and B, which are marked as Triw and Tfiw, should exceed $2^{(n+1)} * \text{clk_32kHz}$.

Only when the timing requirements above are met, can QDEC module recognize wheel rolling times correctly.

9.7 Register table

Table 9- 3 Register table for QDEC

Address	Mnemonic	Type	Description	Reset value
0xd0	QDEC_COUNT	R	QDEC Counting value (read to clear): Pulse edge number	0x00
0xd1	QDEC_CC	R/W	[2:0] : filter time (can filter $2^n * \text{clk_32kHz} * 2$ width deglitch) [4]: pola, input signal pola 0: no signal is low, 1: no signal is high [5]: shuttle mode 1 to enable shuttle mode	0x00
0xd2	QDEC_CHNA	R/W	[2:0] QDEC input pin select for channel a choose 1 of 8 pins for input channel a 0~7: {PD[1], PD[3], PC[3], PB[3]~PB[5], PA[0]~PA[1]}	0x00
0xd3	QDEC_CHNB	R/W	[2:0] QDEC input pin select for channel b choose 1 of 8 pins for input channel b 0~7: {PD[1], PD[3], PC[3], PB[3]~PB[5], PA[0]~PA[1]}	0x01
0xd6	QDEC_RST	R/W	[0]Write 1 to reset QDEC	0x00
0xd7	QDEC_DOUBLE	R/W	[0]QDEC mode select 0-Select common mode 1-Enable double accuracy mode	0x00
0xd8	DATA_LOAD	R/W	[0]write 1 to load data when load completes it will be 0	0x00

10 SAR ADC

The TLSR8367 integrates one SAR ADC module, which can be used to sample analog input signals such as battery voltage and external analog input.

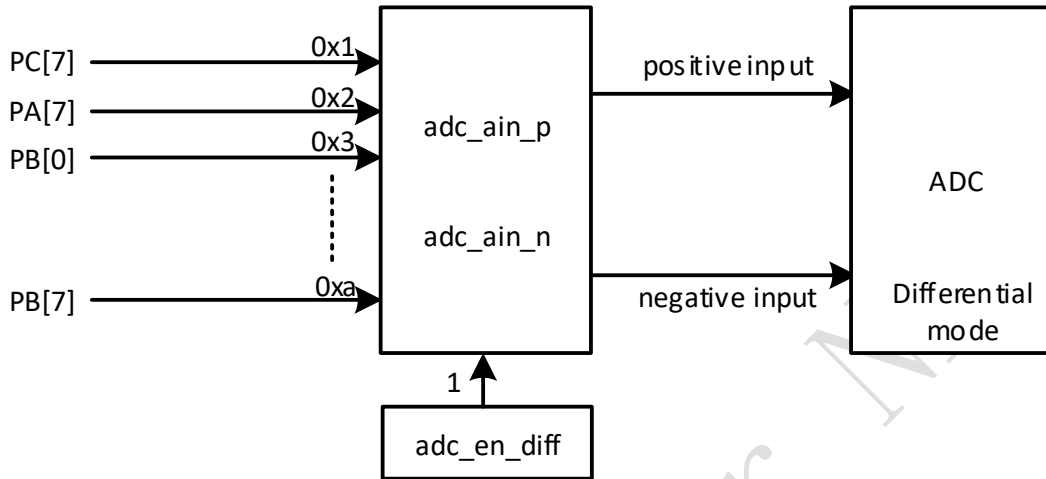

Figure 10- 1 Block diagram of ADC

10.1 Power on/down

The SAR ADC is disabled by default. To power on the ADC, the analog register `adc_pd` (`afe_0xfc<5>`) should be set as 1b'0.

10.2 ADC clock

ADC clock is derived from external 24MHz crystal source, with frequency dividing factor configurable via the analog register `adc_clk_div` (`afe_0xf4<2:0>`).

$$\text{ADC clock frequency (marked as } F_{\text{ADC_clk}}) = 24\text{MHz}/(\text{adc_clk_div}+1)$$

10.3 ADC control in auto mode

10.3.1 Set max state and enable channel

The SAR ADC supports Misc channel. The Misc channel consists of one "Set" state and one "Capture" state.

- ✧ The analog register `r_max_scnt` (`afe_0xf2<6:4>`) serves to set the max state index. As shown below, the `r_max_scnt` should be set as 0x02.

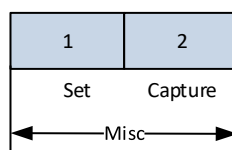

- ✧ The Misc channel can be enabled via `r_en_misc (afe_0xf2<2>)`.
- ✧ RSSI signal sampling channel is multiplexed with the Misc channel.

Note: To sample RSSI signal, it's not needed to enable the Misc channel, and Misc channel input is automatically set as differential `RSSI_n` and `RSSI_p`. Both sampling time and resolution differ.

10.3.2 “Set” state

The length of “Set” state for Misc channel is configurable via the analog register `r_max_s (afe_0xf1<3:0>)`.

“Set” state duration (marked as T_{sd}) = $r_max_s / 24MHz$.

“Set” state serves to set ADC control signals for Misc channel via corresponding analog registers, including:

- ✧ `adc_en_diff: afe_0xec<6>` (Misc channel). Must set as 1b'1 to select differential input mode.
- ✧ `adc_ain_p: afe_0xe8<7:4>` (Misc channel). Select positive input in differential mode.
- ✧ `adc_ain_n: afe_0xe8<3:0>` (Misc channel). Select negative input in differential mode.

***Note:** For RSSI signal sample channel, differential input mode is automatically selected, without the need to set `afe_0xec<6>`, while Misc channel input is automatically set as differential `RSSI_n` and `RSSI_p` without the need to set `afe_0xe8`.

- ✧ `adc_vref: afe_0xe7<5:4>` (Misc channel). Set reference voltage V_{REF} . ADC maximum input range is the determined by the ADC reference voltage.
- ✧ `adc_sel_ai_scale: afe_0xfa<7:6>`. Set scaling factor for ADC analog input as 1 (default), or 1/8.

By setting this scaling factor, ADC maximum input range can be extended based on the V_{REF} .

For example, suppose the V_{REF} is set as 1.2V:

Since the scaling factor is 1 by default, the ADC maximum input range should be 0~1.2V (negative input is GND) / -1.2V~+1.2V (negative input is ADC GPIO pin).

If the scaling factor is set as 1/8, ADC maximum input range should change to 0~9.6V (negative input is GND) / -9.6V~+9.6V (negative input is ADC GPIO pin).

- ✧ `adc_res: afe_0xec<1:0>` (Misc channel). Set resolution as 8/10/12/14 bits.
***Note:** For RSSI signal sample channel, resolution is fixed as 8bits without the need to set `afe_0xec<1:0>`.

ADC data is always 15-bit format no matter how the resolution is set. For example, 14 bits resolution indicates ADC data consists of 14-bit valid data and 1-bit sign extension bit.

- ✧ `adc_tsamp: afe_0xee<3:0>` (Misc channel), `afe_0xee<7:4>` (RSSI signal sample channel). Set sampling time which determines the speed to stabilize input signals.

$$\text{Sampling time (marked as } T_{\text{samp}}) = \text{adc_tsamp} / F_{\text{ADC_clk}}$$

The lower sampling cycle, the shorter ADC convert time.

- ✧ `pga_boost, pga_gain`: Set PGA gain in Boost stage and Gain stage. See PGA section.

10.3.3 “Capture” state

For the Misc channel, at the beginning of “Capture” state, run signal is issued automatically to start an ADC sampling and conversion process; at the end of “Capture” state, ADC output data is captured.

- ✧ The length of “Capture” state for Misc channel is configurable via the analog register `r_max_mc[9:0]` (`afe_0xf1<7:6>`, `afe_0xef<7:0>`).

$$\text{“Capture” state duration for Misc channel (marked as } T_{\text{cd}}) = r_{\text{max_mc}} / 24\text{MHz}$$

- ✧ The “VLD” bit (`afe_0xf8<7>`) will be set as 1b’1 at the end of “Capture” state to indicate the ADC data is valid, and this flag bit will be cleared automatically.
- ✧ The 15-bit ADC output data for Misc channel can be read from the analog register `adc_dat[14:0]` (`afe_0xf8<6:0>`, `afe_0xf7<7:0>`).

Note: The total duration “ T_{td} ”, which is the sum of the length of “Set” state and “Capture” state for Misc channel available, determines the sampling rate.

$$\text{Sampling frequency (marked as } F_s) = 1 / T_{\text{td}}$$

10.3.4 Usage cases

10.3.4.1 Case 1: 1-channel sampling for Misc

In this case, `afe_0xf2<3:0>` should be set as `0x4`, so as to enable the Misc channel, the max state index should be set as “2” by setting `afe_0xf2` as `0x2`.

The total duration (marked as T_{td}) = $(1*r_{max_s}+1*r_{max_mc}) / 24\text{MHz}$.

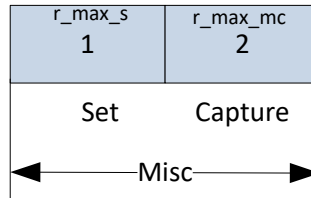

10.3.4.2 Case 2: RSSI capture

RSSI signal sampling channel is shared with the Misc channel. It's not needed to set `r_en_misc` (`afe_0xf2<2>`) to enable Misc channel, while sampling time and resolution differ.

In this case, the `rst_st_en` (`afe_0xf4<7>`) may be set as `1b'1`, which means when RSSI (Received Signal Strength Indication) signal is ready for measurement, and the state machine will be restarted to ensure that the measurement starts from the “Set” state.

In the “Set” state, the `adc_tsamprssi` (`afe_0xee<7:4>`) should be set to configure sampling time.

The sampling resolution is automatically set as 8bits.

RSSI capture channel is automatically set as differential `RSSI_n` and `RSSI_p` input.

The other configurations are the same as the Misc channel.

The total duration (marked as T_{td}) = $(1*r_{max_s}+1*r_{max_mc}) / 24\text{MHz}$.

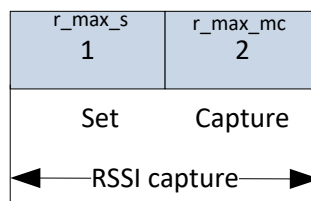

10.3.4.3 Case 3 with detailed register setting

This case introduces the register setting details for Misc channel.

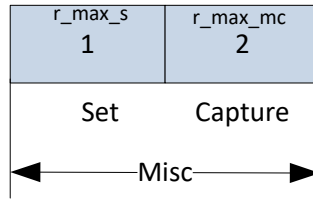

Table 10-1 Overall register setting

Function	Register setting
Power on the ADC	afe_0xfc<5> = 1b'0
Set F_{ADC_clk} (ADC clock frequency) as 4MHz	afe_0xf4<2:0> = 5 $F_{ADC_clk} = 24MHz / (5+1) = 4MHz$
Enable the Misc channel	afe_0xf2<3:0> = 0x4
Set the max state index as "2"	afe_0xf2<6:4> = 0x2

Table 10-2 Register setting for M channel

Function	Register setting for Misc
Set T_{sd} ("Set" state duration)	afe_0xf1<3:0> = 10 $T_{sd} = r_max_s / 24MHz = 10 / 24MHz = 0.417us$
Set T_{cd} ("Capture" state duration)	afe_0xf1<7:6> = 1, afe_0xef<7:0> = 0xea $T_{cd} = r_max_mc[9:0] / 24MHz = 490 / 24MHz = 20.417us$
T_{td} (total duration)	$T_{td} = (1 * r_max_s + 1 * r_max_mc) / 24MHz = 500 / 24MHz = 20.83us$
F_s (Sampling frequency)	$F_s = 1 / T_{td} = 24MHz / 500 = 48kHz$
Set differential input	afe_0xec<6> = 1
Set input channel	afe_0xe8 = 0xaf Select PB[7] and GND as positive input and negative input
Set reference voltage V_{REF}	afe_0xe7<5:4> = 2 $V_{REF} = 1.2V$
Set scaling factor for ADC analog input	afe_0xfa<7:6> = 0 scaling factor: 1 ADC maximum input range: 0 ~ +1.2V
Set resolution	afe_0xec<1:0> = 3 resolution: 14bits
Set T_{samp} (determines the speed to stabilize input before sampling)	afe_0xee<3:0> = 3 $T_{samp} = adc_tsamp / F_{ADC_clk} = 12 / 4MHz = 3us$

10.4 Register table

Table 10- 3 Register table related to SAR ADC

Address	Mnemonic	Default value	Description
afe_0xe7<5:4>	adc_vrefm	00	Select V_{REF} for Misc channel 0x0: rsvd 0x1: 0.9V 0x2: 1.2V 0x3: rsvd
afe_0xe8<3:0>	adc_ain_m_n	0010	Select negative input for Misc channel: 0x0: No input 0x1: PC[7] 0x2: PA[7] 0x3: PB[0] 0x4: PB[1] 0xa: PB[7] 0xb: pga_channel_n<0> (PGA negative output) 0xc: rsvd 0xd: rsvd 0xe: rsvd 0xf: Ground
afe_0xe8<7:4>	adc_ain_m_p	0000	Select positive input for Misc channel: 0x0: No input 0x1: PC[7] 0x2: PA[7] 0x3: PB[0] 0x4: PB[1] 0xa: PB[7] 0xb: pga_channel_p<0> (PGA positive output) 0xc: rsvd 0xd: rsvd 0xe: rsvd 0xf: rsvd
afe_0xec<1:0>	adc_resm	11	Set resolution for Misc channel 0x0: 8bits 0x1: 10bits 0x2: 12bits 0x3: 14bits
afe_0xec<6>	adc_en_diffm	0	Select input mode for Misc channel. 0: rsvd 1: differential mode

Address	Mnemonic	Default value	Description
afe_0xee<3:0>	adc_tsampm	0001	Number of ADC clock cycles in sampling phase for Misc channel to stabilize the input before sampling: 0x0: 3 cycles 0x1: 6 cycles 0x2: 9 cycles 0x3: 12 cycles ... 0xf: 48 cycles
afe_0xee<7:4>	adc_tsamprssi	0000	
afe_0xef<7:0>	r_max_mc[7:0]	0x0f	r_max_mc[9:0] serves to set length of “capture” state for Misc channel. r_max_s serves to set length of “set” state for Misc channel. Note: State length indicates number of 24MHz clock cycles occupied by the state.
afe_0xf1<3:0>	r_max_s	0110	
afe_0xf1<7:6>	r_max_mc[9:8]	00	
afe_0xf2<2>	r_en_misc	1	Enable Misc channel sampling. 1: enable
afe_0xf2<3>	rsvd	0	rsvd
afe_0xf2<6:4>	r_max_scnt	010	Set total length for sampling state machine (i.e. max state index)
afe_0xf4<2:0>	adc_clk_div	011	ADC clock (derive from external 24MHz crystal) ADC clock frequency = 24MHz/(adc_clk_div+1)
afe_0xf4<7>	rst_st_en	0	1: enable state machine restart, 0: disable
afe_0xf5<7:0>	rsvd	0x10	rsvd
afe_0xf6<7:0>	rsvd	0x11	rsvd
afe_0xf7<7:0>	adc_dat[7:0]	0x00	Read only, Misc adc dat[7:0]
afe_0xf8<7:0>	adc_dat[15:8]	0x00	Read only [7]: vld, ADC data valid status bit (This bit will be set as 1 at the end of capture state to indicate the ADC data is valid, and will be cleared when set state starts.) [6:0]: Misc adc_dat[14:8]
afe_0xf9<3:2>	rsvd	00	rsvd
afe_0xf9<5>		0	Must be set as 1b'1
afe_0xfa<7:6>	adc_sel_ai_scale	0	Analog input pre-scaling select sel_ai_scale[1:0]: scaling factor 0x0: 1 0x1: rsvd 0x2: rsvd 0x3: 1/8
afe_0xfc<4>	rsvd	0	rsvd
afe_0xfc<5>	adc_pd	1	Power down ADC 1: Power down 0: Power up

11 PGA

The TLSR8367 integrates a PGA (Programmable Gain Amplifier) module.

The PGA consists of Boost stage pre-amplifier and Gain stage post-amplifier.

The PGA is used in combination with the ADC module: By adjusting the gain of pre-amplifier and post-amplifier, the PGA can amplify differential analog input signals from specific pins before ADC sampling.

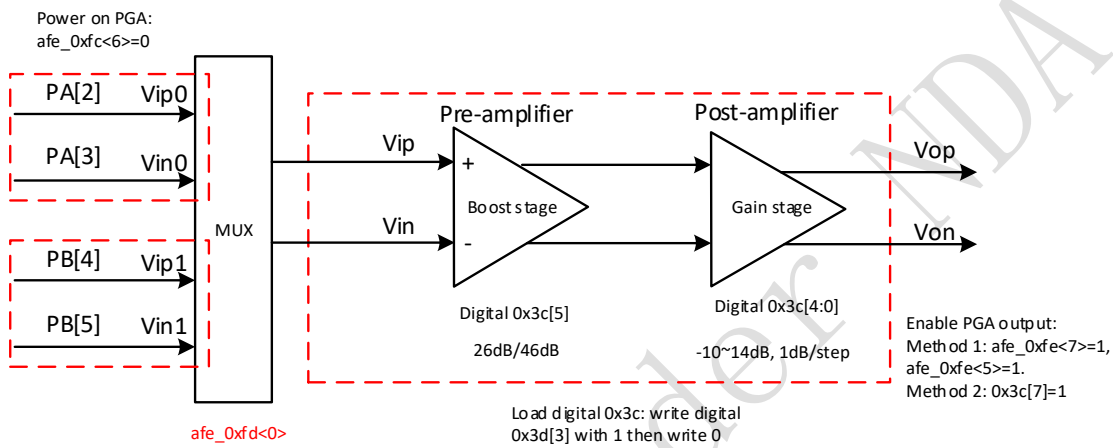

Figure 11- 1 Block diagram of PGA

***Note:**

Vip<0>, Vin<0>: Positive input 0 and Negative input 0;

Vip<1>, Vin<1>: Positive input 1 and Negative input 1;

Vop, Von: Positive and Negative output.

11.1 Power on/down

The PGA is disabled by default.

To power on the PGA, the analog register `pga_pd` (`afe_0xfc<6>`) should be set as `1b'0`.

11.2 Select input channel

The analog register `pga_sel_vin` (`afe_0xfd<0>`) should be set as `1b'1` to select PB[4] and PB[5] as positive and negative input, respectively.

11.3 Adjust gain

The PGA gain is adjustable via digital register `0x3c`:

- ✧ Address `0x3c[5]` serves to set gain for the pre-amplifier as 26dB or 46dB.
- ✧ Address `0x3c[4:0]` serves to set gain for the post-amplifier as -10dB (`0x0`) ~ 14dB (`0x18`) with step of 1dB.
- ✧ The total PGA gain should be the sum of the two gain values.

11.4 Enable/Disable PGA output

User can enable/disable PGA output by using either analog registers or digital register.

- ✧ Use analog register “`pga_mute_m_en`” (`afe_0xfe<7>`) and “`pga_mute_m`” (`afe_0xfe<5>`). User can enable PGA output by setting both `afe_0xfe<7>` and `afe_0xfe<5>` as `1b'1`.
- ✧ Use digital register `0x3c[7]`. User can also enable PGA output by setting `0x3c[7]` as `1b'1`.
- ✧ Digital register `0x3d[4]` indicates whether PGA output is enabled or disabled.

11.5 Load digital register 0x3c

User should write digital register `0x3d[3]` with `1b'1` and `1b'0` to load the value of digital register `0x3c`, so that the configuration of `0x3c` can take effect.

11.6 Register table

Table 11- 1 Analog register table related to PGA

Address	Mnemonic	Default	Description
Analog register			
afe_0xfc<6>	pga_pd	1	Power down PGA 1: Power down, 0: Power up
afe_0xfd<0>	pga_sel_vin	0	Select PGA differential input source. Gate off all input with pga_pd. 0: select PA[2] (positive) and PA[3] (negative) 1: select PB[4] (positive) and PB[5] (negative)
afe_0xfe<7>	pga_mute_m_en	0	Enable using analog register pga_mute_m 0: disable using analog register afe_0xfe<5> 1: enable using analog register afe_0xfe<5>
afe_0xfe<5>	pga_mute_m	0	When afe_0xfe<7> = 0x1, this bit can be used 0: not mute pga 1: mute pga
Digital register			
0x3c		0x00	[4:0]: set gain for the post-amplifier 0x0~0x18: -10dB~14dB, step 1dB [5]: set gain for the pre-amplifier 0: 26dB, 1: 46dB [7]: mute PGA using digital register
0x3d		0x00	[3]: write 1 and then write 0 to trigger PGA load 0x3c value [4]: read only indicate PGA mute release status 0: not release 1: release

12 EEPROM

The TLSR8367E02 embeds 2Kbit EEPROM. To control the EEPROM, PA[5]/PB[6] inside the TLSR8367E02 are connected to the EEPROM and serve as I2C SCL/SDA respectively.

12.1 Communication protocol

Both SDA and SCL are bidirectional lines connected to a positive supply voltage via a pull-up resistor. When the bus is free, both lines are HIGH. Data in SDA line must keep stable when SCL line is at high level, and it's only allowed to change when SCL line is at low level.

A negative/positive edge of SDA when SCL is high indicate a start/stop condition, respectively.

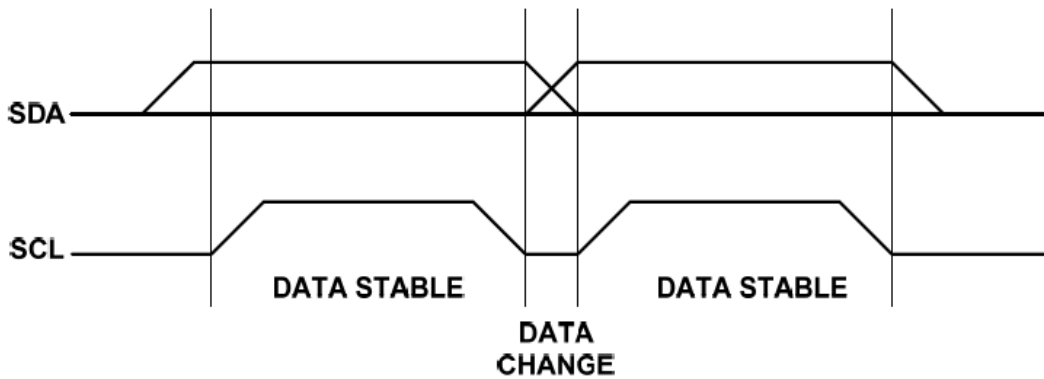

Figure 12- 1 Data validity

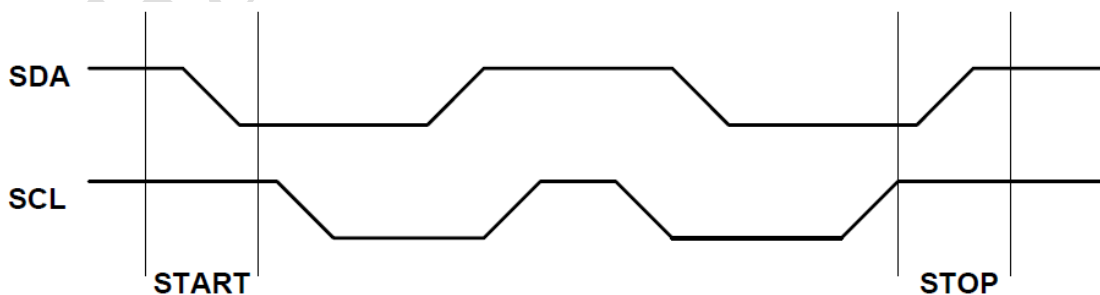

Figure 12- 2 Start and stop condition

All addresses and data words are serially transferred between the EEPROM and the MCU in 8-bit words. The EEPROM will respond with an ack “0” after it receives each word. Upon receipt of each word from the EEPROM, the MCU should also send a “0” to the EEPROM, and continue to output the next data word or send a stop condition.

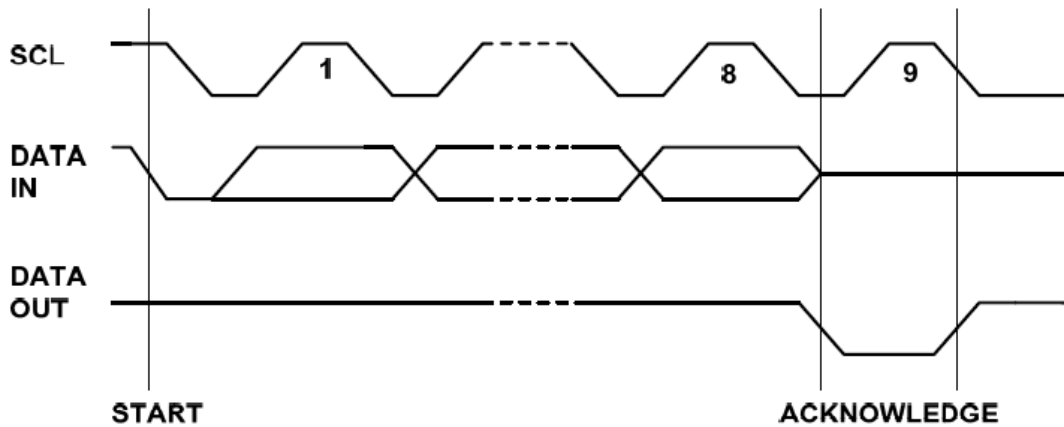

Figure 12- 3 Send Ack

Upon power-up or receipt of the stop bit and completion of any internal operations, the EEPROM will enter low-power standby mode.

The EEPROM requires an 8-bit device address word following a start condition to enable the read/write access operation. As shown in Figure 12- 4, the device address word consists of a mandatory 1, 0 sequence for the first four MSBs, device address bits A₂, A₁ and A₀, as well as R(1)/W(0) select bit to indicate read/write operation.

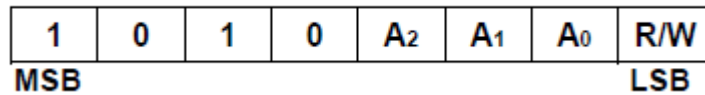

Figure 12- 4 Device address

Since the device address bits “A₂A₁A₀” are “000”, EEPROM I2C address should be 0x50.

12.2 EEPROM operation

For EEPROM read and write operations, user needs to simulate corresponding I2C read/write timing sequence via software.

12.2.1 Write operations

The EEPROM supports byte write and 8-byte page write.

For byte write, a write operation requires an 8-bit data word address following the device address word and ack. Upon receipt of this address, the EEPROM will also respond with an ack “0”, and then the first 8-bit data word is clocked in. After the 8-bit data word is received, the EEPROM will send an ack “0”. The addressing device (MCU) must terminate the write sequence with a stop condition. At this time, the EEPROM enters an internally-timed write cycle to the nonvolatile memory. All inputs are disabled during this write cycle, and the EEPROM won’t respond until the write is completed.

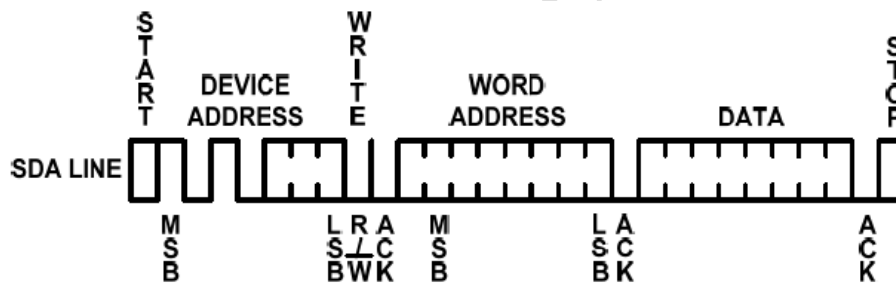

Figure 12- 5 Byte write

A page write initiation is the same as a byte write. The MCU does not send a stop condition after the first data word is clocked in and acknowledged by the EEPROM, and up to seven more data words can be transmitted. The EEPROM will respond with an ack “0” after each data word is received. The MCU must terminate the page write with a stop condition.

For the data word address, the lower three bits are internally incremented following the receipt of each data word, while the higher bits retain the memory page row location. When the word address internally generated reaches the page boundary,

the following byte is placed at the beginning of the same page. If more than eight data words are transmitted to the EEPROM, the data word address will “roll over” and previous data will be overwritten.

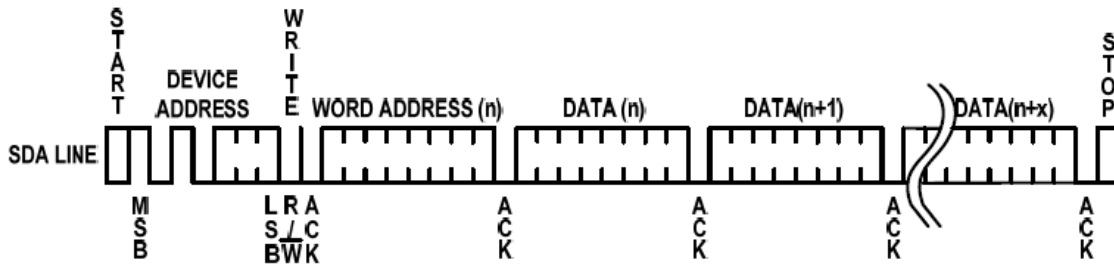

Figure 12- 6 Page write

Once the internally-timed write cycle is started and the EEPROM inputs are disabled, acknowledge polling can be initiated. This involves sending a start condition followed by the device address word. The R/W bit indicates read/write operation. Only if the internal write cycle is completed will the EEPROM respond with an ack “0” allowing the read/write sequence to continue.

12.2.2 Read operations

Read operation initiation is similar to write operation except that the R/W bit in the device address word should be set as “1”. Three read operations are supported, including current address read, random address read and sequential read.

For current address read, the internal data word address counter maintains the last address accessed during the last read/write operation, incremented by 1. This address stays valid between operations as long as the chip power is maintained. The address “roll over” during read is from the last byte of the last memory page to the first byte of the first page. The address “roll over” during write is from the last byte of the current page to the first byte of the same page. Once the device address with the R/W bit set as “1” is clocked in and acknowledged by the EEPROM, the data word of current address is serially clocked out. The MCU will generate a stop condition following NO

ack.

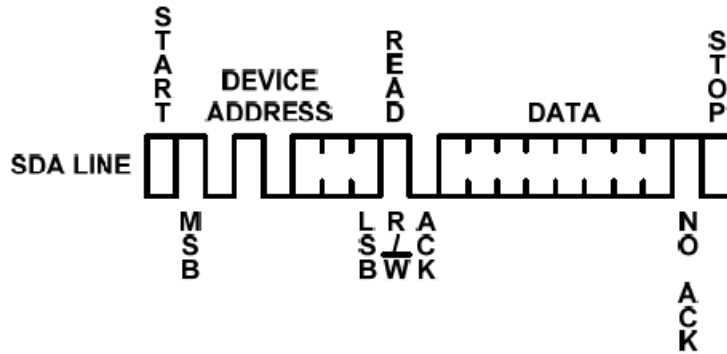

Figure 12- 7 Current address read

A random read requires a “dummy” byte write sequence to load in the data word address. Once the device address word and data word address are clocked in and acknowledged by the EEPROM, the MCU must generate another start condition. The MCU now initiates a current address read by sending a device address with the R/W bit set as “1”. The EEPROM acknowledges the device address and serially clocks out the data word. The MCU will generate a stop condition following NO ack.

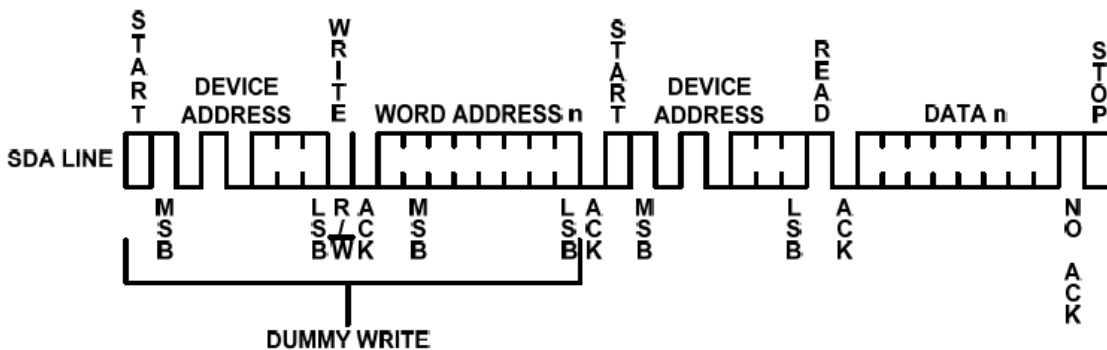

Figure 12- 8 Random read

Sequential read is initiated by either a current address read or a random address read. After the MCU receives a data word, it responds with an ack. As long as the EEPROM receives an ack, it will continue to increment the data word address and serially clock out sequential data words. When the memory address limit (2K) is reached, the data word address will “roll over” and the sequential read will continue. The

sequential read operation is terminated when the MCU generates a stop condition following NO ack.

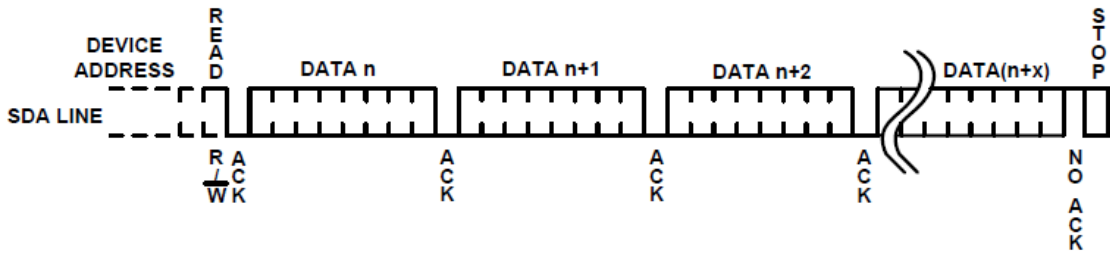

Figure 12- 9 Sequential read

13 AES

The TLSR8367 embeds AES module with encryption and decryption function. The input 128bit plaintext in combination of key is converted into the final output ciphertext via encryption; the 128bit ciphertext in combination of key can also be converted into 128bit plaintext via decryption.

The AES hardware accelerator provides automatic encryption and decryption. It only takes (1000*system clock cycles) to implement AES encryption/decryption. Suppose system clock is 20MHz, the time needed for AES encryption/decryption is 50us.

13.1 RISC mode

For RISC mode, configuration of related registers is as follows:

- 1) Set the value of key via writing registers AES_KEY0~ AES_KEY15 (address 0x550~0x55f).
- 2) Set operation method of AES module via register AES_CTRL: set address 0x540[0] as 1b'1 for decryption method, while clear this bit for encryption method.
- 3) For encryption method, write registers AES-DAT0~ AES-DAT3 (address 0x548~0x54b) for four times to set the 128bit plaintext. After encryption, the 128bit ciphertext can be obtained by reading address 0x548~0x54b for four times.
- 4) For decryption method, write registers AES-DAT0~ AES-DAT3 (address 0x548~0x54b) for four times to set the 128bit ciphertext. After decryption, the 128bit plaintext can be obtained by reading address 0x548~0x54b for four times.
- 5) Address 0x540 bit[1] and bit[2] are read only bits: bit[1] will be cleared automatically after quartic writing of address 0x548~0x54b; bit[2] will be set as 1 automatically after encryption/decryption, and then cleared automatically after quartic reading of address 0x548~0x54b.

13.2 AES-CCM

The AES-CCM (Counter with the CBC-MAC) mode is disabled by default. AES output is directly determined by current encryption and decryption, irrespective of previous encryption and decryption result.

If 0x540[7] is set as 1b'1 to enable AES-CCM mode, AES output will also take previous encryption and decryption result into consideration.

13.3 Register table

Table 13- 1 Register table related to AES

Address	Mnemonic	Type	Description	Reset Value
0x540	AES_CTRL	R/W	[0] Select decrypt/encrypt. 1: decrypt, 0: encrypt [1] Read-only. 1: input data needed, 0: input data ready. [2] Read-only. 0: output data not ready, 1: output data ready. [7] 1: enable AES-CCM mode.	00
0x548	AES-DAT0	R/W	Input/Output Data byte 0	*No power on reset
0x549	AES-DAT1	R/W	Input/Output Data byte 1	
0x54a	AES-DAT2	R/W	Input/Output Data byte 2	
0x54b	AES-DAT3	R/W	Input/Output Data byte 3	
0x550	AES_KEY0	R/W	[7:0] KEY0	00
0x551	AES_KEY1	R/W	[7:0] KEY1	00
0x552	AES_KEY2	R/W	[7:0] KEY2	00
0x553	AES_KEY3	R/W	[7:0] KEY3	00
0x554	AES_KEY4	R/W	[7:0] KEY4	00
0x555	AES_KEY5	R/W	[7:0] KEY5	00
0x556	AES_KEY6	R/W	[7:0] KEY6	00
0x557	AES_KEY7	R/W	[7:0] KEY7	00
0x558	AES_KEY8	R/W	[7:0] KEY8	00
0x559	AES_KEY9	R/W	[7:0] KEY9	00
0x55a	AES_KEY10	R/W	[7:0] KEY10	00
0x55b	AES_KEY11	R/W	[7:0] KEY11	00
0x55c	AES_KEY12	R/W	[7:0] KEY12	00
0x55d	AES_KEY13	R/W	[7:0] KEY13	00
0x55e	AES_KEY14	R/W	[7:0] KEY14	00
0x55f	AES_KEY15	R/W	[7:0] KEY15	00

***Note:** Addresses 0x548~0x54b won't be reset after power on.

14 Key Electrical Specifications

Note: The electrical characteristics currently listed in this section are target specifications and only supplied for reference. Some data may be updated according to actual test results.

14.1 Absolute maximum ratings

Table 14- 1 Absolute Maximum Ratings

Characteristics	Sym.	Min.	Max	Unit	Test Condition
Supply Voltage	VDD	-0.3	4.3	V	All AVDD and DVDD pin must have the same voltage
Voltage on Input Pin	V _{in}	-0.3	VDD+0.3	V	
Output Voltage	V _{Out}	0	VDD	V	
Storage temperature Range	T _{Str}	-65	150	°C	
Soldering Temperature	T _{Sld}		260	°C	

CAUTION: Stresses above those listed in “Absolute Maximum Ratings” may cause permanent damage to the device. This is a stress only rating and operation of the device at these or any other conditions above those indicated in the operational sections of this specification is not implied.

14.2 Recommended operating condition

Table 14- 2 Recommended Operation Condition

Item	Sym.	Min	Typ.	Max	Unit	Condition
Power-supply voltage	VDD	1.9	3.3	4.3	V	QFN package
		1.9	3.3	3.6	V	SOP16 package ¹
Supply rise time (from 0V to 1.9V)	t _R			17.5 ^{*2}	ms	
Operating Temperature Range	T _{Opr}	-40		85	°C	

¹ Note: By changing bonding wire, the SOP16 package can also support the power supply range of 1.9~4.3V.

² Note: For the rise time, if the reset pin cap is 1uF, the supply rise time to 1.9V is recommend to be smaller than 17.5ms as listed above. If larger cap is used, the supply rise time can increase proportionally. If the supply rise time exceeds the max allowed time, especially if the rise from the POR threshold in Section 14.4 to 1.9V is slow, the internal LDO may not settle to the desired states during this period and may lead to unexpected digital logic behavior or worsened RF performance. The rising slope below the POR threshold does not affect much and can be slower.

14.3 Electrical characteristics

Table 14- 3 Electrical characteristics

(Test condition: VDD=3.3V and T=25°C for Typ. value)

Mode	Sym.	Min	Typ.	Max	Unit	Condition
Tx	I _{Tx}		14.5		mA	Continuous TX transmission, 0dBm output power
			25		mA	maximum output power
Rx	I _{Rx}		13.6		mA	Continuous Rx reception
Suspend	I _{Susp}		6.8	20	uA	IO wakeup
			8	20	uA	32k RC wakeup
Deep sleep	I _{Dps}		1.9		uA	internal 32kHz RC OSC off
			3		uA	internal 32kHz RC OSC on

14.4 General characteristics

Table 14- 4 General characteristics

Item	Sym.	Min.	Typ.	Max.	Unit	Condition	
Power-up/ Power-down sequence (see section 2.6.1)							
VDD voltage when V _{UVLO} turns to high level	V _{POR}		1.70		V		
VDD voltage when V _{UVLO} turns to low level	V _{Pdn}		1.62		V		
Delay counter value	T _{PWRst}	Configurable via analog register afe_0x20					
Timing for working mode transition (see section 2.4.3 Power-saving mode)							
Transition time needed from suspend mode to the active mode	T _{SP2A}		500		us		
Transition time needed from deep sleep mode with SRAM retention to active mode	T _{DS2A}		500		us		
Transition time needed from deep sleep mode without SRAM retention to active mode			1		ms		

14.5 Inputs/Outputs characteristics

Table 14- 5 Inputs/Outputs Characteristics

Item	Sym.	Min	Typ.	Max	Unit	Condition
Digital inputs/outputs						
Input high voltage	V _{IH}	0.7V _D D		V _D D	V	
Input low voltage	V _{IL}	V _{SS}		0.3V _D D	V	
Output high voltage	V _{OH}	0.9V _D D		V _D D	V	
Output low voltage	V _{OL}	V _{SS}		0.1V _D D	V	

14.6 Pull-up/Pull-down resistor

 Table 14- 6 Pull-up/Pull-down resistor
(over process and T=-40~+85℃)

Pull-up/Pull-down resistor	Min	Max	Condition
x1 pull-up	8	11	V _D D=3.3~4.3V
	10	12	V _D D=3V
	16	19	V _D D=1.9V
x10 pull-down	128	136	V _D D=3.3~4.3V
	174	188	V _D D=3V
	465	496	V _D D=1.9V
x100 pull-up	756	785	V _D D=3.3~4.3V
	953	1003	V _D D=3V
	2011	2246	V _D D=1.9V

14.7 SPI characteristics

Table 14- 7 SPI characteristics

(over process, voltage 1.9~4.3V, and T=-40~+85°C)

Item	Sym.	Min	Typ.	Max	Unit	Condition
CK frequency	F _{CK}			4	MHz	Slave
CK duty cycle clock			50		%	Master
DI setup time		30			ns	Slave
		90			ns	Master
DI hold time		10			ns	Slave
		90			ns	Master
CK low to DO valid time				30	ns	Slave
				120	ns	Master
CN setup time		60			ns	Master/Slave
CN high to DI tri-state* ³					ns	Master

³ Note: Master actively stops reading during transmission, and Slave releases its driver DO and turns to tri-state.

14.8 I2C characteristics

Table 14- 8 I2C characteristics

(over process, voltage 1.9~4.3V, and T=-40~+85°C)

Item	Sym.	Standard mode		Fast mode		Unit	Condition
		Min	Max	Min	Max		
SCL frequency	F _{SCL}		100		400	kHz	
Rise time of SDA and SCL signals	T _R		1000		300	ns	
Fall time of SDA and SCL signals	T _F		300		300	ns	
START condition hold time	T _{HD;STA}	4		0.6		us	
Data hold time	T _{HD;DAT}	0	3.45		0.9	us	
Data setup time	T _{SU;DAT}	250		100		ns	
STOP condition setup time	T _{SU;STO}	4		0.6		us	

14.9 RF performance

Table 14- 9 RF characteristics

Item		Min	Typ.	Max	Unit	Condition
RF frequency range		2380		2500	MHz	Programmable in 1MHz step
Data rate	2.4GHz 1Mbps, ± 250 kHz deviation 2.4GHz 2Mbps, ± 500 kHz deviation					
2.4GHz 1Mbps RF_Rx performance						
Sensitivity	1Mbps		-90		dBm	
Frequency Offset Tolerance		-300		+300	kHz	
Co-channel rejection			5		dB	Wanted signal at -67dBm
In-band rejection C/I (modulation interference)	± 1 MHz offset		0		dB	Wanted signal at -67dBm
	± 2 MHz offset		-30		dB	
	± 3 MHz offset		-34		dB	
	>4 MHz offset		-40		dB	
Image rejection			-34		dB	Wanted signal at -67dBm
2.4GHz 1Mbps RF_Tx performance						
Output power, maximum setting			7		dBm	
Output power, minimum setting			-20		dBm	
Programmable output power range			27		dB	
Modulation 20dB bandwidth			1.5		MHz	
Adjacent channel power ratio (ACPR)	$F_0 \pm 2$ MHz		57		dBc	
	$F_0 \pm 4$ MHz		64		dBc	
	$F_0 \pm (>4)$ MHz		66		dBc	
Inband Emission	2MHz		-41		dBm	
	≥ 3 MHz		-42		dBm	
Spurious Emission Conducted Measurement	$f < 1$ GHz		-70		dBm	T=25 °C , Max Output Power, Max Voltage
	$f > 1$ GHz		-68		dBm	
2.4GHz 2Mbps RF_Rx performance						
Sensitivity	2Mbps		-86.5		dBm	
Frequency Offset Tolerance		-200		+200	kHz	
Co-channel			7		dB	Wanted signal

Item		Min	Typ.	Max	Unit	Condition
rejection						at -67dBm
In-band rejection C/I (modulation interference)	±2MHz offset		-4		dB	Wanted signal at -67dBm
	±4MHz offset		-31		dB	
	±6MHz offset		-38		dB	
	≥8MHz offset		-42		dB	
Image rejection			-40		dB	Wanted signal at -67dBm
2.4GHz 2Mbps RF_Tx performance						
Output power, maximum setting			7		dBm	
Output power, minimum setting			-20		dBm	
Programmable output power range			27		dB	
Modulation 20dB bandwidth			2.6		MHz	
Adjacent channel power ratio (ACPR)	$F_0 \pm 4\text{MHz}$		53		dBc	
	$F_0 \pm 6\text{MHz}$		63		dBc	
	$F_0 \pm (>6\text{MHz})$		62		dBc	
Spurious Emission Conducted Measurement	$f < 1\text{GHz}$		-70		dBm	T=25 °C , Max Output Power, Max Voltage
	$f > 1\text{GHz}$		-68		dBm	
RSSI						
RSSI range		-88		-30	dBm	
RSSI Resolution			+/-4		dB	

14.10 Crystal characteristics

Table 14- 10 Crystal characteristics

(Test condition: VDD=3.3V, T=25°C)

Item	Sym.	Min	Typ.	Max	Unit	Condition
24MHz crystal						
Nominal frequency (parallel resonant)	f_{NOM}		24		MHz	
Frequency tolerance	f_{TOL}	-20		+20	ppm	
Load capacitance	C_L	5	12	18	pF	Programmable on chip load cap (PV @ 25°C for min and Max)
Equivalent series resistance	ESR		40	80	ohm	PVT

14.11 RC oscillator characteristics

Table 14- 11 RC oscillator characteristics

(Test condition: VDD=3.3V, T=25°C)

Item	Sym.	Min	Typ.	Max	Unit	Condition
24MHz RC oscillator						
Nominal frequency	f_{NOM}		24		MHz	
Frequency tolerance	f_{TOL}		0.07		%	With calibration
32kHz RC oscillator						
Nominal frequency	f_{NOM}		32		kHz	
Frequency tolerance	f_{TOL}		0.45		%	With calibration
Calibration time			3		ms	

14.12 ADC characteristics

Table 14- 12 ADC characteristics

(over process, voltage 1.9~3.6V, and T=-40~+85°C)

Item	Sym.	Min	Typ.	Max	Unit	Condition
Differential nonlinearity	DNL				LSB	
Integral nonlinearity	INL				LSB	
Signal-to-noise ratio	SNR				dB	$f_{in}=1\text{kHz}$, $f_S=16\text{kHz}$
Total harmonic distortion	THD				dB	$f_{in}=628.66\text{Hz}$, $f_S=100\text{kHz}$
Effective Number of Bits	ENOB				bits	

Sampling frequency	Fs				kHz	
--------------------	----	--	--	--	-----	--

15 Application

*Note: Not all pin functions are listed in the reference design of this section.

15.1 Application example for TLSR8367EP16

15.1.1 Schematic

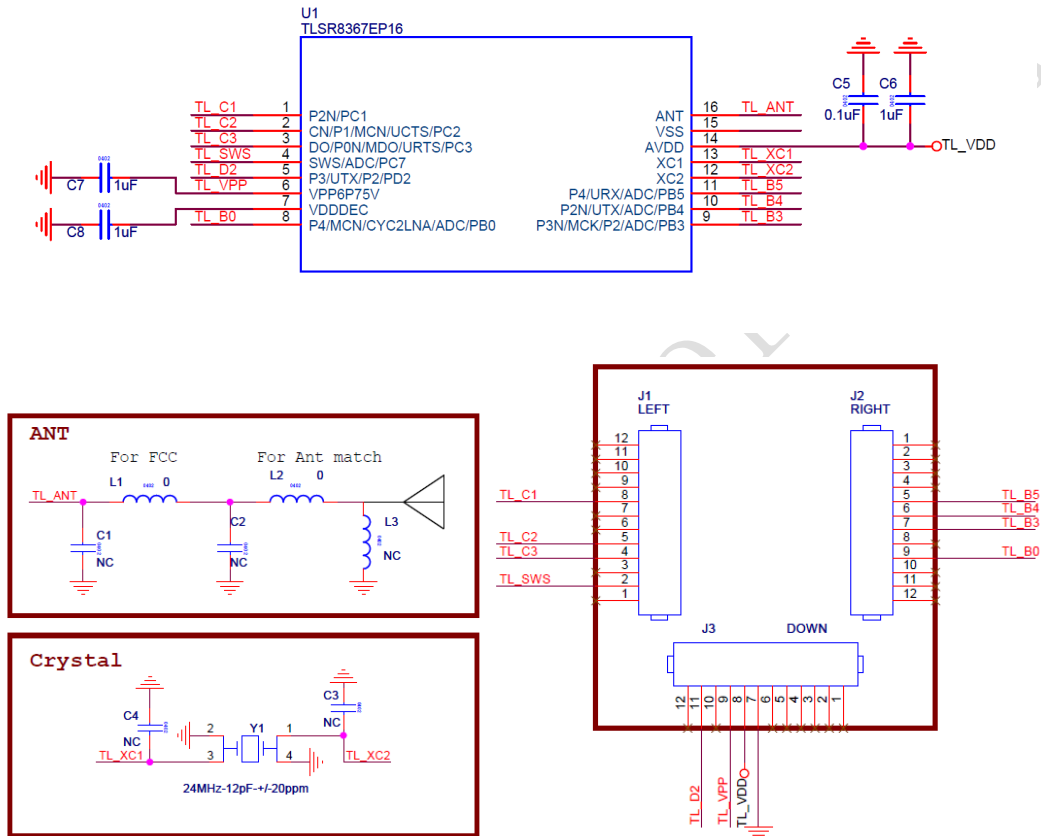

Figure 15- 1 Schematic for TLSR8367EP16

15.1.2 BOM (Bill of Material)

Table 15- 1 BOM table for TLSR8367EP16

Quantity	Reference	Description
1	C5	0.1uF
3	C6	1uF
	C7	1uF
	C8	1uF
1	J1	LEFT
1	J2	RIGHT
1	J3	DOWN
2	L1	0
	L2	0
1	U1	TLSR8367EP16
1	Y1	24MHz-12pF+/-20ppm

X-ON Electronics

Largest Supplier of Electrical and Electronic Components

Click to view similar products for [RF System on a Chip - SoC category](#):

Click to view products by [Telink manufacturer](#):

Other Similar products are found below :

[BCM20737A1KML2G](#) [BCM43236BKMLG](#) [EM06ELA-512-SGAS](#) [CYBL10463-56LQXI](#) [CYBL10562-56LQXI](#) [CYBL10563-68FLXIT](#)
[ATBTLC1000A-UU-T](#) [EC25AUFA-MINIPCIE](#) [BCM43242KFFBG](#) [BCM20707UA1KFFB1G](#) [ATWILC1000B-UU-T](#) [BCM4322KFBGH](#)
[ETRX3DVK357](#) [EC25VFA-MINIPCIE](#) [EC25JFA-MINIPCIE](#) [EC25MXGA-MINIPCIE](#) [EC25AFXGA-MINIPCIE](#) [EC25AUXGA-MINIPCIE](#)
[EC25AUGC-MINIPCIE](#) [EC25AUTFA-MINIPCIE](#) [EC25AFFA-MINIPCIE](#) [EP06ALA-512-SGAD](#) [EM06ALA-512-SGAD](#) [EM12GPA-512-](#)
[SGAD](#) [EC25EUGA-MINIPCIE](#) [TLR8367EP16](#) [EC25AFA-MINIPCIE](#) [CYBL10463-56LQXIT](#) [CC2511F32RSPR](#) [AX-SFEU-API-1-01-](#)
[TB05](#) [NRF51422-CFAC-R](#) [NRF51822-CDAB-R](#) [XR1015-QH-0G00](#) [EM3585-RT](#) [NCH-RSL10-101Q48-ABG](#) [AX8052F143-3-TX30](#)
[BLUENRG-232](#) [ESP32-D2WD](#) [AWR1642ABIGABLQ1](#) [ESP32-D0WD](#) [ESP8266EX](#) [CYBL10561-56LQXI](#) [ATWINC1500B-MU-Y](#)
[DA14531-00000FX2](#) [ESP32-C3FH4](#) [ESP32-C3](#) [ESP32-D0WDQ6](#) [ESP32-D0WDQ6-V3](#) [ESP32-D0WD-V3](#) [ESP32-PICO-V3](#)