

TENMA[®]

72-7224 / 72-7226

Operating Manual



Digital Clamp Multimeters



Table of Contents

Title	Page
Overview	3
Inspection	4
Safety Information	5
Rules For Safe Operation	6
International Electrical Symbols	9
The Meter Structure	10
Rotary Switch	11
Function Buttons	12
Button Use	14
Display Symbols	15
Measurement Operation	18
A. DC/AC Voltage Measurement	18
B. Measuring Resistance	20
C. Testing Diodes	22
D. Testing for Continuity	24
E. Frequency Measurement	26
F. Duty Cycle Measurement	28
G. DC/AC Current Measurement	30



Title	Page
Sleep Mode	32
Specifications	33
A. General Specifications	33
B. Environmental Requirements	34
Accuracy Specifications	35
A. DC Voltage	35
B. AC Voltage	36
C. Resistance	37
D. Diode Test	37
E. Continuity Test	38
F. Frequency	39
G. Duty Cycle	40
H. DC Current	40
I. AC Current	42
Maintenance	44
A. General Service	44
B. Replacing the Battery	45

Overview

This Operating Manual covers information on safety and cautions. Please read the relevant information carefully and observe all the **Warnings** and **Notes** strictly.



Warning

To avoid electric shock or personal injury, read the “Safety Information” and “Rules for Safe Operation” carefully before using the Meter.

Digital Clamp Multimeter **Models 72-7224 and 72-7226** (hereafter referred to as “the Meter”) are 3 3/4 digits with precise operation, fashionable structure and highly reliable measuring instrument. The Meter uses large scale of integrated circuit with double integrated A/D converter as its core and has full range overload protection.

Both models measure AC/DC Voltage, AC/DC Current, Frequency, Duty Cycle, Resistance, Diodes and Continuity, and also include Data Hold, Sleep Mode and Relative Mode features.

Model 72-7226 also provides True RMS measurement.



Inspection

Open the package case and take out the Meter. Check the following items carefully to see if any items are missing or damaged.

Item	Description	Qty
1	English Operating Manual	1 piece
2	Test Lead	1 pair
3	Carrying Bag	1 piece
4	9V Battery (NEDA1604, 6F22 or 006P)	1 piece

In the event you find any items missing or damaged, please contact your dealer immediately.

Safety Information

This Meter complies with the standards IEC61010: in pollution degree 2, overvoltage category (CAT. II 600V, CAT. III 300V) and double insulation.

CAT. II: Local level, appliance, PORTABLE EQUIPMENT etc., with smaller transient overvoltages than CAT. III.

CAT. III: Distribution level, fixed installation, with smaller transient overvoltages than CAT. IV

Use the Meter only as specified in this operating manual, otherwise the protection provided by the Meter may be impaired.

In this manual, a **Warning** identifies conditions and actions that pose hazards to the user, or may damage the Meter or the equipment under test.

A **Note** identifies the information that user should pay attention to.

International electrical symbols used on the Meter and in this Operating Manual are explained on page 9.

Rules For Safe Operation

Warning













To avoid possible electric shock or personal injury, and to avoid possible damage to the Meter or to the equipment under test, adhere to the following rules:

- 1 Before using the Meter inspect the case. Do not use the Meter if it is damaged or the case (or part of the case) is removed. Look for cracks or missing plastic. Pay attention to the insulation around the connectors.
- 1 Inspect the test leads for damaged insulation or exposed metal. Check the test leads for continuity. Replace damaged test leads with identical model number or electrical specifications before using the Meter.
- 1 Do not apply more than the rated voltage, as marked on the Meter, between the terminals or between any terminal and ground. If the value to be measured is unknown, use the maximum measurement position and reduce the range step by step until a satisfactory reading is obtained.
- 1 When measurement has been completed, disconnect the connection between the test leads and the circuit under test, remove the test leads away from the input terminals of the Meter and turn the Meter power off.

- 1 **The rotary switch should be placed in the correct position and no change of range made during measurement, to prevent damage to the Meter.**
- 1 **Do not carry out the measurement when the Meter's back case and battery compartment are not closed to avoid electric shock.**
- 1 **Do not input higher than 600V between the two Meter's input terminal to avoid electric shock and damages to the Meter.**
- 1 **When working at an effective voltage over 60VDC or 30VAC RMS, special care should be taken for there is danger of electric shock.**
- 1 **Use the proper terminals, function, and range for your measurements.**
- 1 **Do not use or store the Meter in an environment of high temperature, humidity, explosive, inflammable and strong magnetic field. The performance of the Meter may deteriorate after dampened.**
- 1 **When using the test leads, keep your fingers behind the finger guards.**
- 1 **Disconnect circuit power and discharge all high-voltage capacitors before testing resistance, continuity and diode.**
- 1 **Replace the battery as soon as the battery indicator  appears. With a low battery, the Meter might produce false readings that can lead to electric shock and personal injury.**
- 1 **When servicing the Meter, use only the same model number or identical electrical specifications replacement parts.**

- 1 **The internal circuit of the Meter shall not be altered at will to avoid damage of the Meter and any accident.**
- 1 **Soft cloth and mild detergent should be used to clean the surface of the Meter when servicing. No abrasive and solvent should be used to prevent the surface of the Meter from corrosion, damage and accident.**
- 1 **The Meter is suitable for indoor use.**
- 1 **Turn the Meter off when it is not in use and take out the battery when not using for a long time.**
- 1 **Periodically check the battery as it may leak after some time. If leakage is apparent, the battery should be immediately replaced to prevent damage to the Meter.**

International Electrical Symbols

	AC (Alternating Current)
	DC (Direct Current)
	AC or DC
	Ground
	Double Insulated
	Warning. Refer to the Operating Manual
	Low Battery
	Continuity Test
	Diode
	Fuse
	Application around and removal from HAZARDOUS LIVE conductors is permitted.
	Conforms to Standards of European Union

The Meter Structure (see figure 1)

1. Input Terminals
2. LCD Display
3. Function Buttons
4. Rotary Switch
5. Trigger: press the lever to open the transformer jaws. When the pressure on the lever is released, the jaws will close.
6. Hand Guards: to protect user's hand from touching the dangerous area.
7. Transformer Jaw: designed to pick up the AC and DC current flowing through the conductor. The conductor under test should pass perpendicular through the jaw.

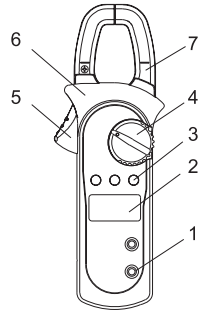

(figure 1)

Rotary Switch

The following table provides information regarding the Rotary Switch positions.

Rotary Switch Position	Function
OFF	Power is turned off
$V\sim$	AC or DC voltage measurement
Ω	Resistance measurement
$\rightarrow /\bullet)$	$\rightarrow $: Diode test $\bullet)$: Continuity test
Hz / Duty%	Frequency Measurement and Duty Measurement
40A \sim & 400A \sim	AC and DC current measurement range

Function Buttons

The following table provides information regarding the rotary switch positions.

Button	Operation Performed
HOLD	<ul style="list-style-type: none">1 Press HOLD to enter the Hold mode in any mode, the Meter will beep to confirm.1 Press HOLD again to exit the Hold mode, the Meter will again beep to confirm.
RELΔ	<p>At V\sim and Ω range:</p> <ul style="list-style-type: none">1 The Meter is defaults to auto ranging mode. Press the REL key to select manual ranging mode.1 When the Meter is at manual ranging mode, press to step down the range. <p>At A\sim range:</p> <ul style="list-style-type: none">1 Press to enter the REL mode.1 It subtracts a stored value from the present measurement value and displays a result. <p>At Hz/Duty% range:</p> <ul style="list-style-type: none">1 Press to switch between Hz measurement mode and Duty % measurement mode.

Button	Operation Performed
SELECT	<ul style="list-style-type: none"><li data-bbox="308 305 1112 409">1 Press SELECT button to select the alternate functions marked in blue colour on the Meter's faceplate including $V \sim$, $\rightarrow \leftarrow \bullet \parallel$, $40 A \sim$, and $400 A \sim$.<li data-bbox="308 419 1112 476">1 If the meter enters sleep mode, press and hold the SELECT button to reactivate meter.

Function Button Use



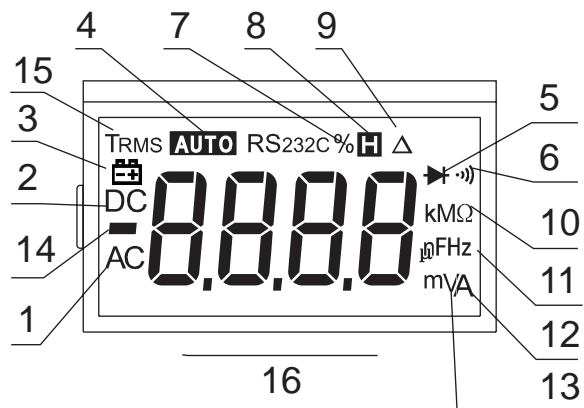

Not every function button is used in every rotary switch position. The table below indicates which button can be used in which switch position.

Rotary Switch Positions	Function Buttons		
	SELECT	REL Δ	HOLD
V \approx	1	1	1
Ω	N/A	1	1
\rightarrow / \bullet)	1	N/A	1
Hz / Duty%	N/A	1	1
40A \approx	1	1	1
400A \approx	1	1	1

Display Symbols (see figure 2)



(figure 2)

Number	Symbol	Meaning
1	AC	Indicator for AC voltage or current
2	DC	Indicator for DC voltage
3		The battery is low. Warning: To avoid false readings, which could lead to possible electric shock or personal injury, replace the battery as soon as the battery indicator appears.
4	AUTO	The Meter is in the auto range mode in which the Meter automatically selects the range with the best resolution.
5		Diode test.
6		The continuity buzzer is on
7	%	Indicator for Duty.
8	H	Data hold is active
9		Indicator for REL mode

Number	Symbol	Meaning
10	$\Omega, k\Omega, M\Omega$	Ω : Ohm. The unit of resistance. k Ω : Kiloohm. 1×10^3 or 1000 ohms M Ω : Megohm. 1×10^6 or 1,000,000 ohms
11	Hz	The unit of Frequency
12	A	Amperes (amps). The unit of current.
13	mV, V	Volts. The unit of voltage. mV: Millivolt. 1×10^{-3} or 0.001 volts
14	—	Indicates negative reading
15	TRMS	Indicator for TRMS mode
16	OL	The input value is too large for the selected range

Measurement Operation

A. DC/AC Voltage Measurement (see figure 3)

Warning

To avoid damage to the meter, or risk of personal injury, do not attempt to measure higher than 600V AC/DC, although readings may be obtained.

The DC Voltage ranges are:
400mV, 4V, 40V, 400V and 600V.

The AC Voltage ranges are:
4V, 40V, 400V and 600V.

To measure DC voltage, connect the Meter as follows:

1. Insert the red test lead into the Hz Duty%  V Ω terminal and the black test lead into the **COM** terminal.

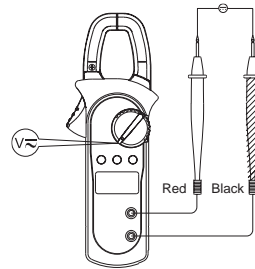

(figure 3)

2. Set the rotary switch to **V $\overline{\sim}$** . DC measurement mode and auto ranging is a default.
Press **SELECT** to switch to AC measurement mode or press **REL Δ** to switch to manual ranging measurement mode.
3. Connect the test leads across with the object being measured.
The measured value shows on the display.

Note

- 1 When DC/AC voltage measurement has been completed, disconnect the test leads from the circuit under test, and remove them from the input terminals.

B. Measuring Resistance (see figure 4)

Warning

To avoid damage to the Meter or to the devices under test, disconnect circuit power and discharge all the high-voltage capacitors before measuring resistance.

The resistance ranges are:
400 Ω , 4k Ω , 40k Ω , 400k Ω , 4M Ω and 40M Ω .

To measure resistance, connect the Meter as follows:

1. Insert the red test lead into the Hz Duty% $\bullet \rightarrow V \Omega$ terminal and the black test lead into the **COM** terminal.
2. Set the rotary switch to Ω . Resistance measurement is default to auto range mode, press **REL** Δ to switch to manual ranging measurement mode.
3. Connect the test leads across with the object being measured. The measured value shows on the display.

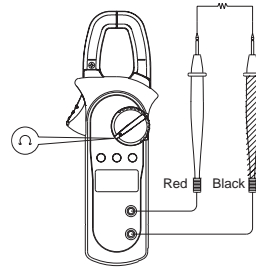

(figure 4)



Note

- 1 For precise reading, the device under test should first be removed from its circuit.
- 1 When resistance measurement has been completed, disconnect the test leads from the circuit under test, and remove them from the input terminals.

C. Testing Diodes (see figure 5)

Warning

To avoid damage to the Meter or to the devices under test, disconnect circuit power and discharge all the high-voltage capacitors before testing diodes.



Use the diode test to check diodes, transistors, and other semiconductor devices. The diode test sends a current through the semiconductor junction, then measure the voltage drop across the junction. A good silicon junction drops between 0.5V and 0.8V.

To test the diode out of a circuit, connect the Meter as follows:

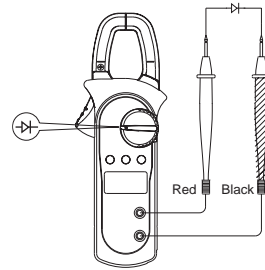
1. Insert the red test lead into the Hz Duty%  $V\Omega$ terminal and the black test lead into the **COM** terminal.



(figure 5)

2. Set the rotary switch to . Diode measurement mode is a default or press **SELECT** to select  measurement mode.
3. For forward voltage drop readings on any semiconductor component, place the red test lead on the component's anode and place the black test lead on the component's cathode.

Note

- 1 To obtain a more precise reading, You could removing the object from its circuit will allow more accurate measurement.
- 1 When diode testing has been completed, disconnect the test leads from the circuit under test, and remove them from the input terminals.

D. Testing for Continuity (see figure 6)

Warning

To avoid damage to the Meter or to the devices under test, disconnect circuit power and discharge all the high-voltage capacitors before measuring continuity.

To test for continuity, connect the Meter as follows:

1. Insert the red test lead into the Hz Duty%  $\rightarrow V \Omega$ terminal and the black test lead into the **COM** terminal.
2. **COM** terminal.

Set the rotary switch to  and press **SELECT**

3. button to select  measurement mode.

The buzzer sounds if the resistance of a circuit under test is less than 50Ω

4. The buzzer may or may not sound if the resistance of a circuit under test is between 50Ω to 100Ω
5. The buzzer will not sound if the resistance of a circuit under test is higher than 100Ω

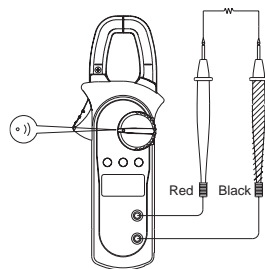

(figure 6)



Note

- 1 When continuity testing has been completed, disconnect the test leads from the circuit under test, and remove them from the input terminals.

E. Frequency Measurement (see figure 7)

Warning

To avoid damage to the meter, or risk of personal injury, do not attempt to measure higher than 600V AC/DC, although readings may be obtained.

The frequency ranges are:

10Hz, 100Hz, 1kHz, 10kHz, 100kHz, 1MHz and 10MHz.

To measure frequency, connect the Meter as follows:

1. Insert the red test lead into the Hz Duty%  terminal and the black test lead into the **COM** terminal.
2. Set the rotary switch to **Hz**.
3. Connect the test leads across with the object being measured.
The measured value shows on the display.

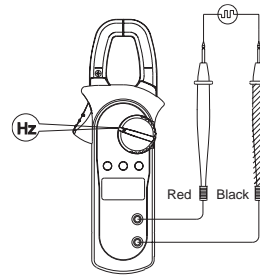

(figure 7)

Note

- 1 When frequency measurement has been completed, disconnect the test leads from the circuit under test, and remove them from the input terminals.



F. Duty Cycle Measurement (see figure 8)

Warning

To avoid damage to the meter, or risk of personal injury, do not attempt to measure higher than 600V AC/DC, although readings may be obtained.

The duty cycle range is: 0.1%~99.9%.

To measure duty cycle, connect the Meter as follows:

1. Insert the red test lead into the Hz Duty%  terminal and the black test lead into the **COM** terminal.
2. Set the rotary switch to **Hz** and press **REL**  to select Duty Cycle measurement mode.
3. Connect the test leads across with the object being measured.
The measured value shows on the display.

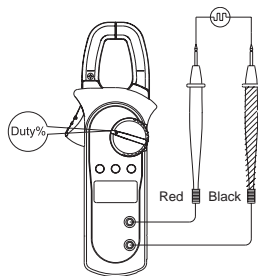

(figure 8)

Note

- 1 When duty cycle measurement has been completed, disconnect the test leads from the circuit under test, and remove them from the input terminals.

G. DC/AC Current Measurement (see figure 9)

The measurement ranges of current are: 40.00 **A** \approx and 400.0 **A** \approx .

To measure current, do the following:

1. Set the rotary switch to 40 **A** \approx or 400 **A** \approx . DC measurement mode is a default. Press **SELECT** to switch between DC and AC measurement mode.
2. Hold the Meter tight, don't release. The Hall components are very sensitive not only to the magnet but also to heat and machine reaction force. It is important that the meter be held firmly and steadily during current measurement.
3. Press the lever to open the transformer jaw.
4. Center the conductor within the transformer jaw, then release the Meter slowly until the transformer jaw is completely closed. For best accuracy, it is important that the conductor under test be placed in the center of the transformer jaw, perpendicular to the jaw. Measure only one conductor at a time, multiple conductors in the transformer clamp will cause inaccuracy.

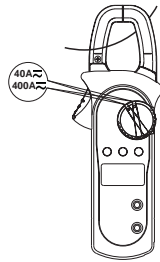

(figure 9)

Note

- 1 Press **REL**△ to subtract a stored value from the present measurement value and display a result.
- 1 When current measurement has been completed, disconnect the connection between the conductor under test and the jaw, press the lever to open the transformer jaw again and remove the jaw from the conductor under test.

Sleep Mode

To preserve battery life, the Meter automatically turns off after 15 minutes of inactivity.

The Meter can be activated by pressing any button or changing the position of the rotary switch.

Approximately one minute before entering sleep mode, the buzzer will beep five times. Immediately before entering sleep mode, the buzzer will provide one long beep.

To disable the Sleep Mode function, press and hold **SELECT** button while turning on the Meter.

Specifications

A. General Specifications:

- 1 Maximum Voltage between any Terminals and ground: Refer to different range input protection voltage.
- 1 Display: 3 3/4 digits LCD display, Maximum display 3999
- 1 Polarity: Automatically display.
- 1 Overload: Display **OL** or **-OL**
- 1 Low battery: Display 
- 1 Measurement Speed: Updates 3 times/second.
- 1 Measurement Deviation: The conductor being measured is not placed in the center of the jaw during AC/DC current measurement, it will cause extra $\pm 1\%$ deviation based on the stated accuracy.
- 1 Drop Test: 1 meter drop test passed.
- 1 Max. Jaw Size: 1.1" (28mm) diameter.
- 1 Projected Max. Current conductor size: 1.0" (26mm) diameter.
- 1 Power: 1 x 9V battery (NEDA1604 or 6F22 or 006P)

- | Battery Life: typically 150hours (alkaline battery)
- | Sleep Mode (can be disabled)
- | Dimensions (H x W x L): 208mm x 76mm x 30mm.
- | Weight: Approximate 260g (battery included)

B. Environmental Requirements

- | The Meter is suitable for indoor use.
- | Altitude: Operating: 2000m
Storage: 10000m
- | Safety/ Compliances: IEC 61010 CAT.II 600V, CAT.III 300V over voltage and double insulation standard.
- | Temperature and humidity:
 - Operating: 0°C~30°C (≤ 85%R.H);
 - 30°C~40°C (≤ 75%R.H);
 - 40°C~50°C (≤ 45%R.H);
 - Storage: -20°C~+60°C (≤ 85%R.H)

Note:

Use near strong electromagnetic fields may cause inaccurate and undesirable readings.

Accuracy Specifications

Accuracy: $\pm(a\% \text{ reading} + b \text{ digits})$, guarantee for 1 year.

Operating temperature: $23^{\circ}\text{C} \pm 5^{\circ}\text{C}$

Relative humidity: $\leq 85\% \text{R.H}$

Temperature coefficient: $0.1 \times (\text{specified accuracy}) / 1^{\circ}\text{C}$

A. DC Voltage

Range	Resolution	Accuracy	Overload protection
400.0mV	0.1mV	$\pm(0.8\%+3)$	600V DC/AC
4.000V	1mV	$\pm(0.8\%+1)$	
40.00V	10mV		
400.0V	100mV		
600V	1V	$\pm(1\%+3)$	

Remarks: Input impedance: $10\text{M}\Omega$

B. AC Voltage

Range	Resolution	Accuracy	Overload protection
4.000V	1mV	±(1%+5)	600V DC/AC
40.00V	10mV		
400.0V	100mV		
600V	1V	±(1.2%+5)	

Remarks:

l Input impedance: 10MΩ// less than 100pF

l Frequency response: 40Hz~400Hz.

l **Change to AC:**

➤ **72-7224:**

Change to AC by using average response method. Input sine wave, then adjust the reading until it is same as the effective value.

➤ **72-7226:**

Combine AC and True RMS response method. Input sine wave to adjust. Non sine wave must follow the below data to adjust:

Peak factor: 1.4~2.0, add 1.0% on the stated accuracy

Peak factor: 2.0~2.5, add 2.5% on the stated accuracy

Peak factor: 2.5~3.0, add 4.0% on the stated accuracy.

C. Resistance

Range	Resolution	Accuracy	Overload protection
400.0Ω	100mΩ	±(1.2%+2)	600Vp
4.000kΩ	1Ω	±(1%+2)	
40.00kΩ	10Ω		
400.0kΩ	100Ω		
4.000MΩ	1kΩ	±(1.2%+2)	
40.00MΩ	10kΩ	±(1.5%+2)	

D. Diode Test

Range	Resolution	Accuracy	Overload protection
	1mV	Display approximate forward voltage drop: 0.5V~0.8V	600Vp

Remark: Open circuit voltage approximate 1.48V.

E. Continuity Test

Range	Resolution	Accuracy	Overload protection
•)	100mΩ	Around $\leq 50\Omega$, the buzzer beeps	600Vp

Remark:

- l Open circuit voltage approximate 0.45V.
- l The buzzer may or may not beeps when the resistance of a circuit under test is between $50\Omega\sim 100\Omega$
- l The buzzer will not beep when the resistance of a circuit under test is $> 100\Omega$.

F. Frequency

Range	Resolution	Accuracy	Overload protection
10Hz	0.001Hz	$\pm(0.1\%+3)$	600Vp
100Hz	0.01Hz		
1kHz	0.1Hz		
10kHz	1Hz		
100kHz	10Hz		
1MHz	100Hz		
10MHz	1kHz	For reference only	

Remark:

Input Sensitivity as follows:

When $\leq 100\text{kHz}$: $\geq 300\text{mV rms}$;

When $> 100\text{kHz}$: $\geq 600\text{mV rms}$

When $> 1\text{MHz}$: $\geq 800\text{mV rms}$

G. Duty Cycle

Range	Resolution	Accuracy	Overload protection
0.1%~99.9%	0.1%	For reference only	600Vp

H. DC Current

Range	Resolution	Accuracy	Overload protection
40.00A	0.01A	$\pm(2\%+5)$	400A DC/AC
400.0A	0.1A	$\pm(2\%+3)$	

**Warning**

The operating temperature must be 0°C ~40°C when measuring current.

Remark:

- 1 To obtain a positive reading when measuring DC current, the current must flow in the direction from the rear of the meter to the front. Hold the Meter tight, do not release. The Hall components are very sensitive not only to the magnet but it is important that the meter be held firmly and steadily during current measurement.

- 1 Hold the Meter tight and press the lever to open the transformer jaw. Center the conductor within the transformer jaws, then release the Meter slowly until the transformer jaw is completely closed. Make sure the conductor to be tested is placed at the center of the transformer jaw, otherwise it will cause +1.0% deviation based on the stated accuracy.
- 1 Remove the transformer jaw.
- 1 Press **REL**△ to display zero.
- 1 Repeat the above 1. procedure.
- 1 The obtained reading will be more precise.

I. AC Current

Range	Resolution	Accuracy	Frequency Response	Overload protection
40.00A	0.01A	$\pm(2.5\%+8)$	50Hz ~ 60Hz	400A DC/AC
400.0A	0.1A	$\pm(2.5\%+5)$		

 **Warning**

The operating temperature must be 0°C ~40°C when measuring current.

Remark:

It may have 10 digits or less unstable or wrong digits, it will not affect measurement result.

I Change to AC:

➤ **72-7224:**

Change to AC by using average response method. Input sine wave, then adjust the reading until it is same as the effective value.

➤ **72-7726:**

Combine AC and True RMS response method. Input sine wave to adjust. Non sine wave must follow the below data to adjust:

Peak factor: 1.4~2.0, add 1.0% on the stated accuracy

Peak factor: 2.0~2.5, add 2.5% on the stated accuracy

Peak factor: 2.5~3.0, add 4.0% on the stated accuracy.

MAINTENANCE

This section provides basic maintenance information including battery replacement instruction.



Do not attempt to repair or service your Meter unless you are qualified to do so and have the relevant calibration, performance test, and service information.

To avoid electrical shock or damage to the Meter, do not get water inside the case.

A. General Service

- 1 Periodically wipe the case with a damp cloth and mild detergent. Do not use abrasives or solvents.
- 1 To clean the terminals with cotton bar with detergent, as dirt or moisture in the terminals can affect readings.
- 1 Turn the Meter power off when it is not in use.
- 1 Take out the battery if the meter will not be used for a long period of time.
- 1 Do not use or store the Meter in a place of humidity, high temperature, explosive, inflammable and strong magnetic field.

B. Replacing the Battery (see figure 10)



Warning

To avoid false readings, which could lead to possible electric shock or personal injury, replace the battery as soon as the battery indicator “” appears.

Make sure the transformer jaw and the test leads are disconnected from the circuit being tested before opening the case bottom.

To replace the battery:

1. Turn the Meter off and remove all the connections from the input terminals
2. Turn the Meter's front case down.
3. Remove the screw from the battery compartment, and separate the battery compartment from the case bottom.
4. Take out the old battery and replace with a new 9V battery (NEDA1604, 6F22 or 006P).
5. Rejoin the case bottom and the battery compartment, and reinstall the screw.

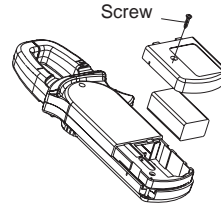

(figure 10)

** END **

This operating manual is subject to change without notice.



Model 72-7224 / 72-7226: OPERATING MANUAL

©Copyright 2006 Tenma Test Equipment.
All rights reserved.

Tenma Test Equipment
405 S. Pioneer Blvd.
Springboro, Ohio 45066
www.tenma.com

X-ON Electronics

Largest Supplier of Electrical and Electronic Components

Click to view similar products for [tenma manufacturer](#):

Other Similar products are found below :

[21-10164](#) [21-10158](#) [72-7715](#) [BC0024434](#) [72-7712](#) [76-009](#) [76-081](#) [CBB019217](#) [CBB018722](#) [72-9170](#) [72-13668](#) [72-13686](#) [72-13688](#) [72-13736](#) [72-13742](#) [72-13818](#) [72-13822](#) [72-13824](#) [72-13836](#) [72-13856](#) [72-13858](#) [72-13872](#) [72-13874](#) [72-13908](#) [72-13950](#) [72-13986](#) [72-14060](#) [72-14302](#) [72-3099](#) [76-1448](#) [76-1556](#) [76-019](#) [76-024](#) [76-1568](#) [21-670](#) [72-14400](#) [72-13762](#) [72-13826](#) [72-13832](#) [72-13888](#) [72-13942](#) [72-14008](#) [72-14014](#) [72-14048](#) [72-14148](#) [72-14230](#) [72-17175](#) [72-2655](#) [72-7615](#) [76-097](#)