

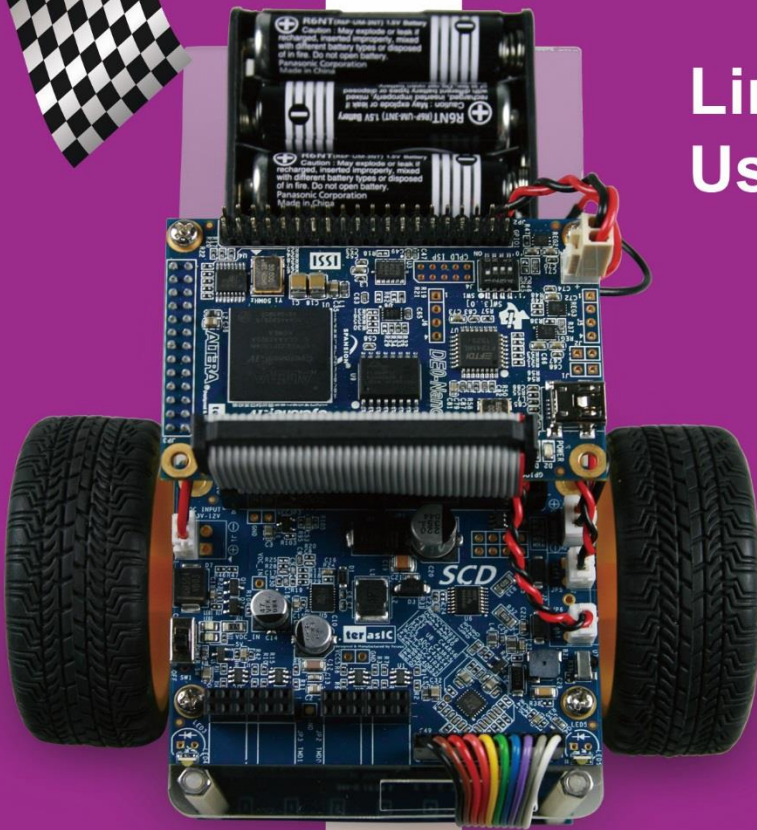

Line Following Robot User Manual



terasic
www.terasic.com

Copyright © 2016 Terasic Technologies Inc. All Rights Reserved.

CONTENTS

| | | |
|------------------|-------------------------------------|-----------|
| Chapter 1 | Introduction | 2 |
| 1.1 | About the Package | 2 |
| 1.2 | Getting Help | 3 |
| Chapter 2 | Architecture of A-Cute..... | 4 |
| 2.1 | Features | 4 |
| 2.2 | Component and Layout | 5 |
| 2.3 | How to make your car work | 7 |
| Chapter 3 | Hardware of A-Cute | 10 |
| 3.1 | Over View..... | 10 |
| 3.2 | DE0-Nano Cyclone IV FPGA Board..... | 11 |
| 3.3 | SCD (Smart Car Daughter) Card..... | 13 |
| 3.3.1 | Power System | 14 |
| 3.3.2 | Motor Driver..... | 15 |
| 3.3.3 | ADC LTC2308 | 17 |
| 3.3.4 | User Buzzer and LED..... | 19 |
| 3.3.5 | IR Receiver..... | 20 |
| 3.3.6 | TMD Header..... | 21 |
| Chapter 4 | Appendix | 23 |
| 4.1 | Revision History | 23 |
| 4.2 | Copyright Statement | 23 |

Chapter 1

Introduction

A-Cute Car is a high performance self-propelled robotic line tracking vehicle, and has a complete input / output interface. It is easy to understand, simple to program, users can learn to operate it quickly.

It uses four AA size batteries pack and runs on a stand-alone power system. The motor operates in a voltage range between 3.6V ~ 6.8V.

A-Cute uses two gear motor to drive the wheels, and is equipped with 7 reflective sensors (as sensing inputs), two white LED lamps for lighting, and also has a buzzer.

1.1 About the Package

The A-Cute kit comes with the following contents:

1. A-Cute car body
2. 4-pack AA size batteries
3. IR Remote control
4. USB Mini-B cable
5. 5V Power Supply
6. DC Adapter Cable
7. Quick Start Guide

Users can download A-Cute system CD from the following address <http://car.terasic.com/cd/>. The system CD contains technical documents of the A-Cute kit; included with it is component datasheets, demonstrations, a schematic, a cable and a user manual.

Figure 1-1 shows the contents of A-Cute kit.



Figure 1-1 Contents of A-Cute Car Kit

1.2 Getting Help

Here is information of how to get help if you encounter any problem:

Office Hours: 9:00 a.m. to 6:00 p.m. (GMT +8)

Telephone: +886-3-550-8800

Email: support@terasic.com

Architecture of A-Cute

This chapter provides information regarding features and architecture of the A-Cute.

2.1 Features

The key features of this module are listed below:

- Power by DC 3.3V ~ 12V
- AA x4 battery Holder
- Accelerated by FPGA
- Buzzer
- White LED for illumination
- Seven sensor array to follow the line
- ADC chip to digitized the input power and line sensors
- Line following
- Remote Control by Bluetooth
- Remote Control by IR
- Expansion Headers
-

2.2 Component and Layout

The top view of A-Cute is shown in the picture below **Figure 2-1**.

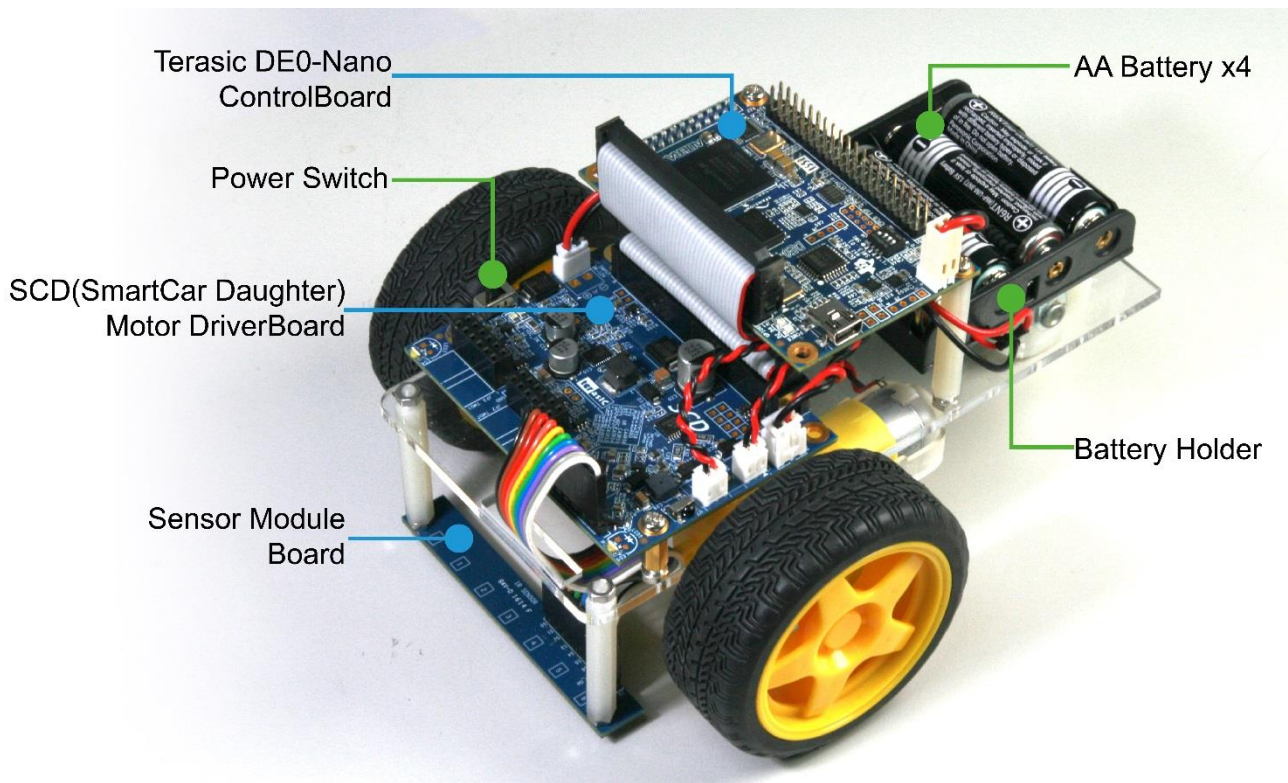

Figure 2-1 A-Cute Car Top View

The bottom view of A-Cute is shown in **Figure 2-2**.

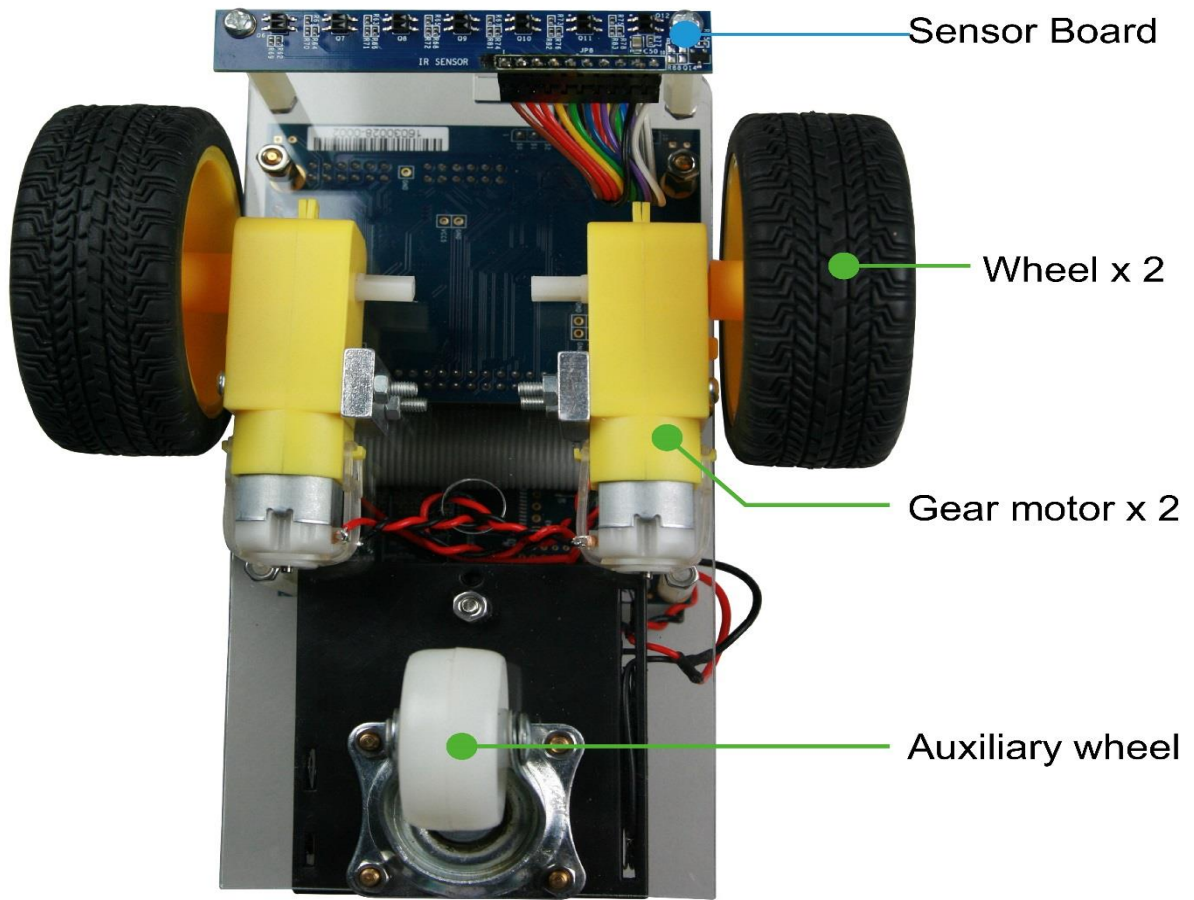

Figure 2-2 A-Cute Car Bottom View

2.3 How to make your car work

Battery Selection and Installation

A-Cute car package requires 4 AA batteries. You can choose carbon-zinc batteries, alkaline batteries or NiMH batteries. We recommend using rechargeable NiMH batteries.

Carbon-zinc / alkaline batteries are rated voltage of 1.5V, and NiMH batteries rated voltage of 1.2V.

Because of the voltage difference of the 2 types of batteries, the operating voltages supplied to the motor will differ; therefore, the NiMH batteries will run the motor at a slower speed than carbon-zinc / alkaline batteries.

Make sure to check which direction the batteries are installed. Match the positive end of the batteries to the positive on the battery box, and the negative end of the batteries to the negative end of the battery box.

Ready to turn on the power

When the battery is properly installed; turn on the power switch.

You will see the switch next to the two power lights, switch to the on position, the power light on the car and the DE0-Nano will light up.

Now you can begin to enjoy the fun of A-Cute.

2.4 Use the DC adapter power

The A-Cute Car Robot Kit has provided a 5V power supply for development users.

Users can use the DC Power cable in lieu of the battery by connecting the 5V power supply to the A-Cute Car Robot Kit.

Please refer to the following steps for connection procedures:

1. Unplug the J1 cable (battery cable) from the battery box to SCD; refer to **Figure 2-3**.

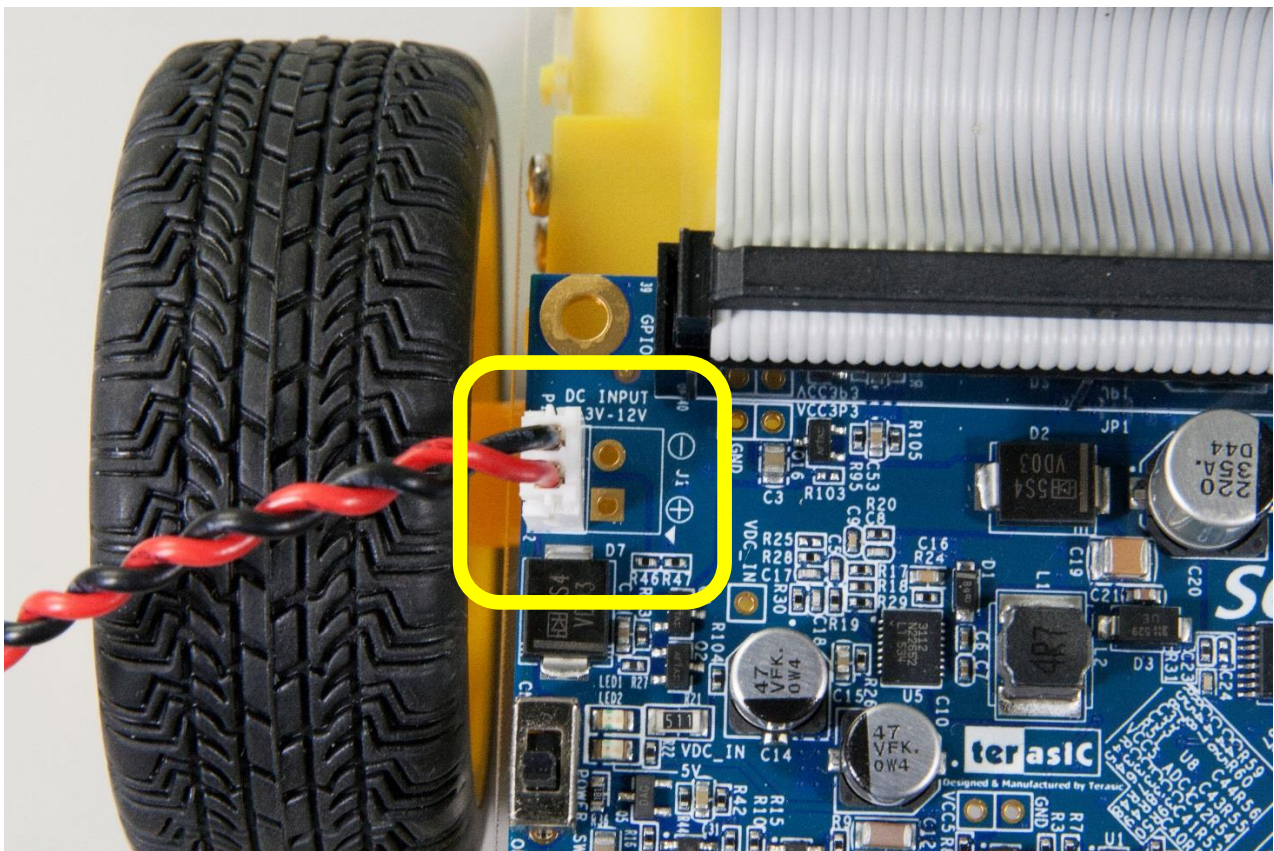

Figure 2-3 J1 position on SCD board

2. Connect the DC Power cable and the 5V power supply; refer to **Figure 2-4**.

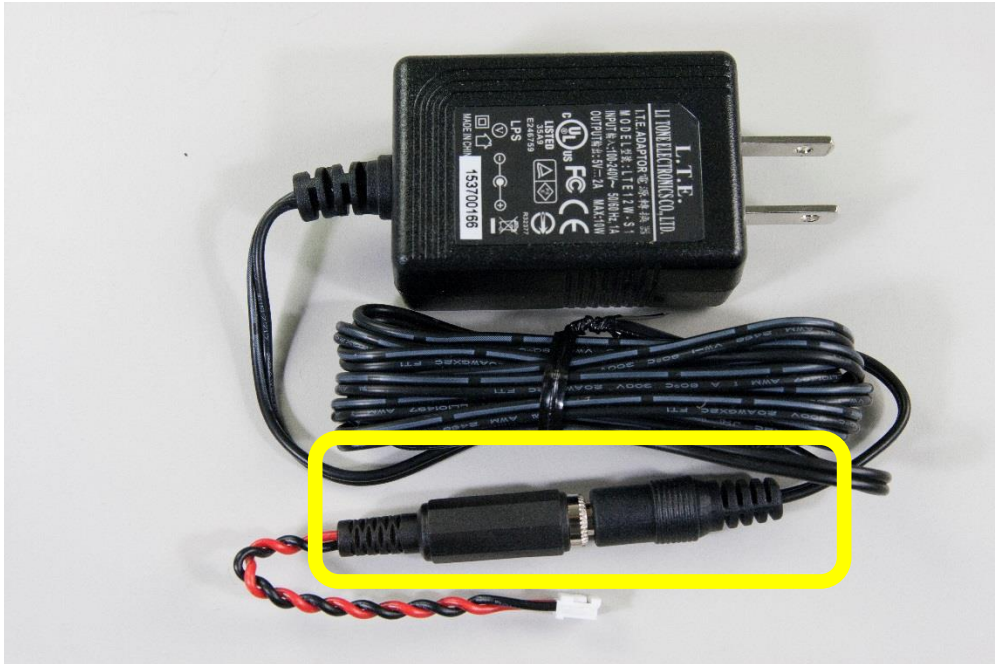

Figure 2-4 Connect DC adapter cable and 5V power adapter.

3. Insert the other end of the DC Power cable connector into the J1 connector (battery cable) on the SCD. The completed connection is shown in **Figure 2-5**.

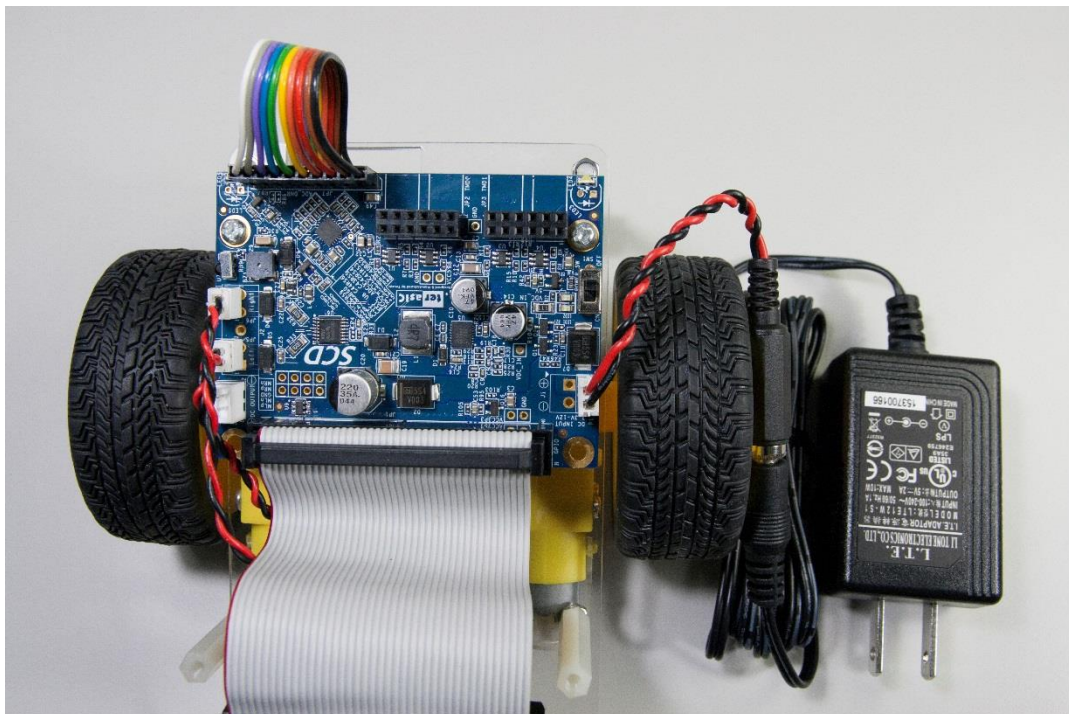

Figure 2-5 Complete connection diagram

Hardware of A-Cute

3.1 Overview

A-Cute is mainly a combination of three boards, the chassis, motor and other components combined. Please reference to **Figure 3-1**. Below we will introduce the three boards.

The first board to be introduced is the main controller called Terasic DE0-Nano Board. This board uses the Altera Cyclone IV FPGA chip as the main control board. It is responsible for the entire A-Cute car control system.

The second is the A-Cute driver board. It was designed and developed by Terasic SCD (Smart Car Daughter) Card. It is responsible for converting the battery power and driving the motor.

The third is to introduce A-Cute Sensor Module Board. It is placed at the front of the car. It is used for sensing the ground black line, enabling the car to follow the black line in a forward direction.

A-Cute body is composed of acrylic, with two geared motor groups, and 66mm diameter rubber wheels. The third wheel (a training wheel) is attached to the front of the body.

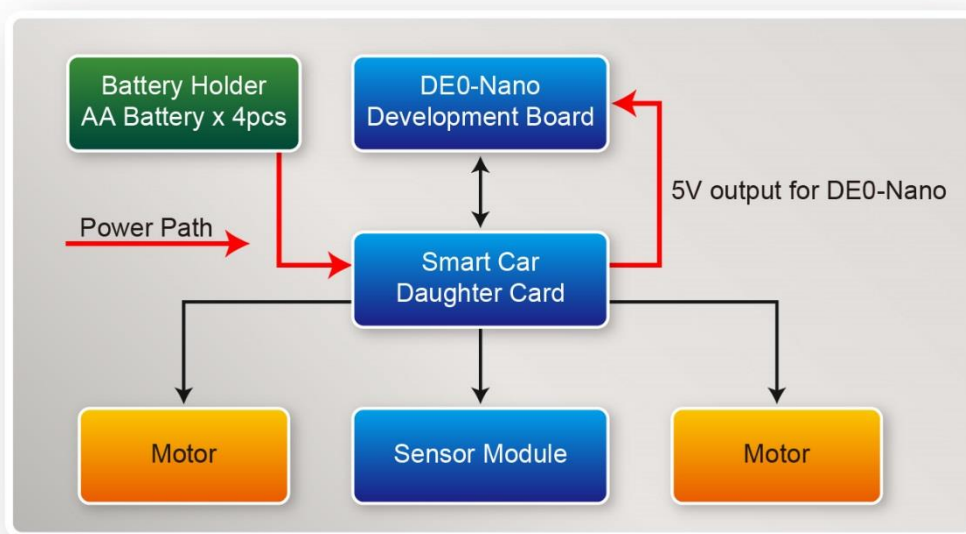

Figure 3-1 A-Cute Architecture

In the following sections, we will discuss each board's functions and features.

3.2 DE0-Nano Cyclone IV FPGA Board

The DE0-Nano Development Board is an A-Cute Car system controller. It uses the NIOS II Processor as a control system. It has a variety of appropriate peripheral IP's that are constructed by a self-propelled complete tracking control system.

Below are the DE0-Nano Board detailed specifications and reference designs. Please refer to the following URL : [Altera DE0-Nano](#)

A-Cute basic structure refers to the block diagram in **Figure 3-2**.

The system is structured as follows:

1. It uses the NIOS II processor-based controllers, allowing users to use the C language development, saving time and effort.
2. A mount PWM IP, you can control DC Motor Forward and reverse as well as an increase / decrease in speed, for precise control over the movement of the vehicle.
3. There mounted SPI interface IP for external ADC. The system uses the sensor to detect the current ground state.
4. A PIO IP is attached to the control power switch, LED, buzzer, and other devices.

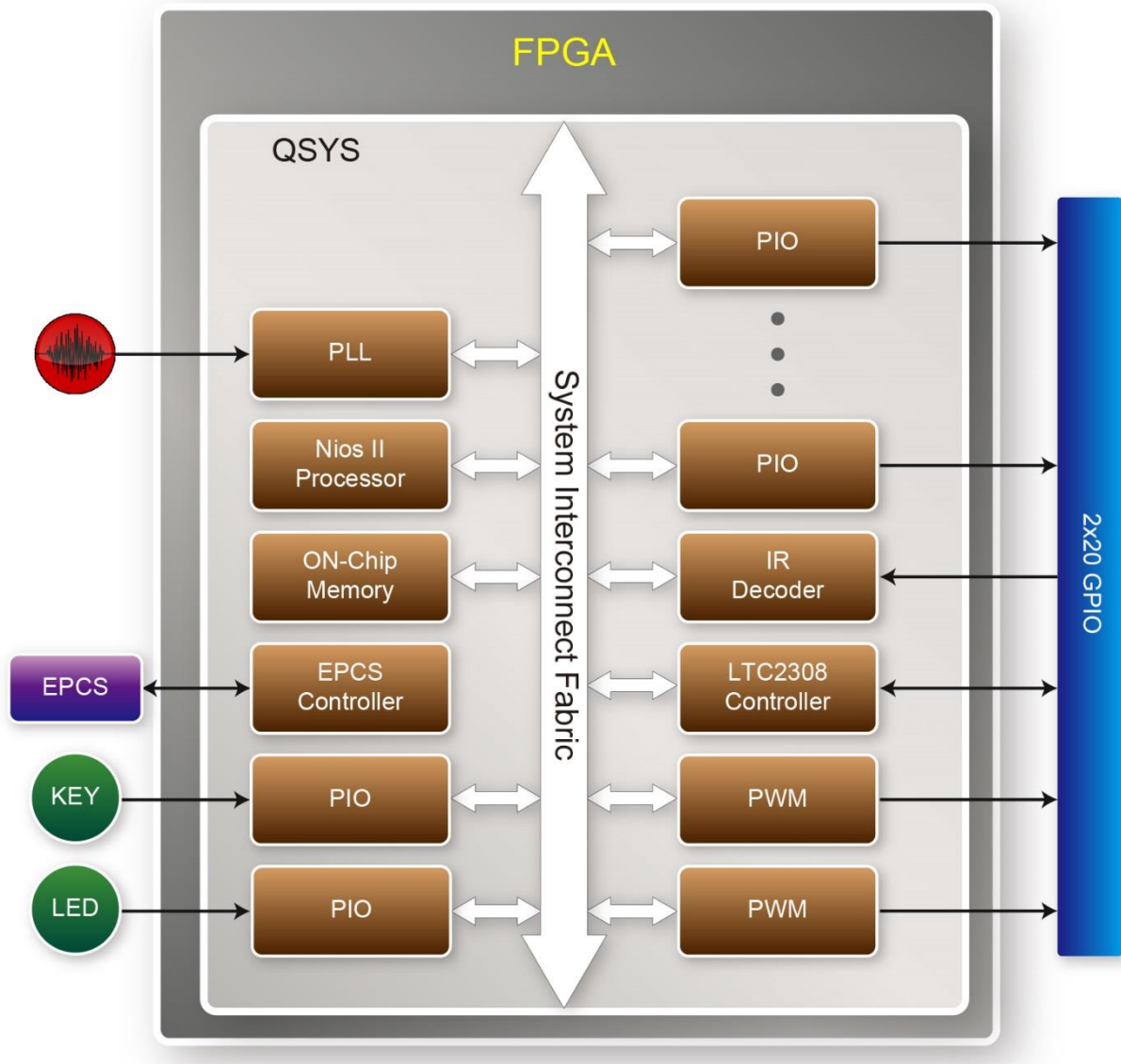

Figure 3-2 DE0-Nano Board Basic structure

3.3 SCD(Smart Car Daughter) Card

Smart Car Daughter was developed for the two wheels of the car, the infrared sensing, and motor drive control board. It can be connected to any GPIO Port on the Terasic board. This allows users to easily control the DC Motor, achieving automatic control purposes. The main functions of the board:

1. Power System: Buck-Boost DC/DC Converter, 5V/2A output for Control Board Power supply.
2. Motor Driver: Can drive two Brushless DC Motors.
3. ADC: 8-channel for IR Sensor input and Battery power meter.
4. LED: Two white LED for illumination.
5. Buzzer: You can play some sound.
6. TMD (Terasic Mini Digital) expansion header: Can use Bluetooth Daughter ([BTS-TMD](#)) for the expansion of remote control.

Figure 3-3, the description of the SCD Card hardware architecture and scalable system.

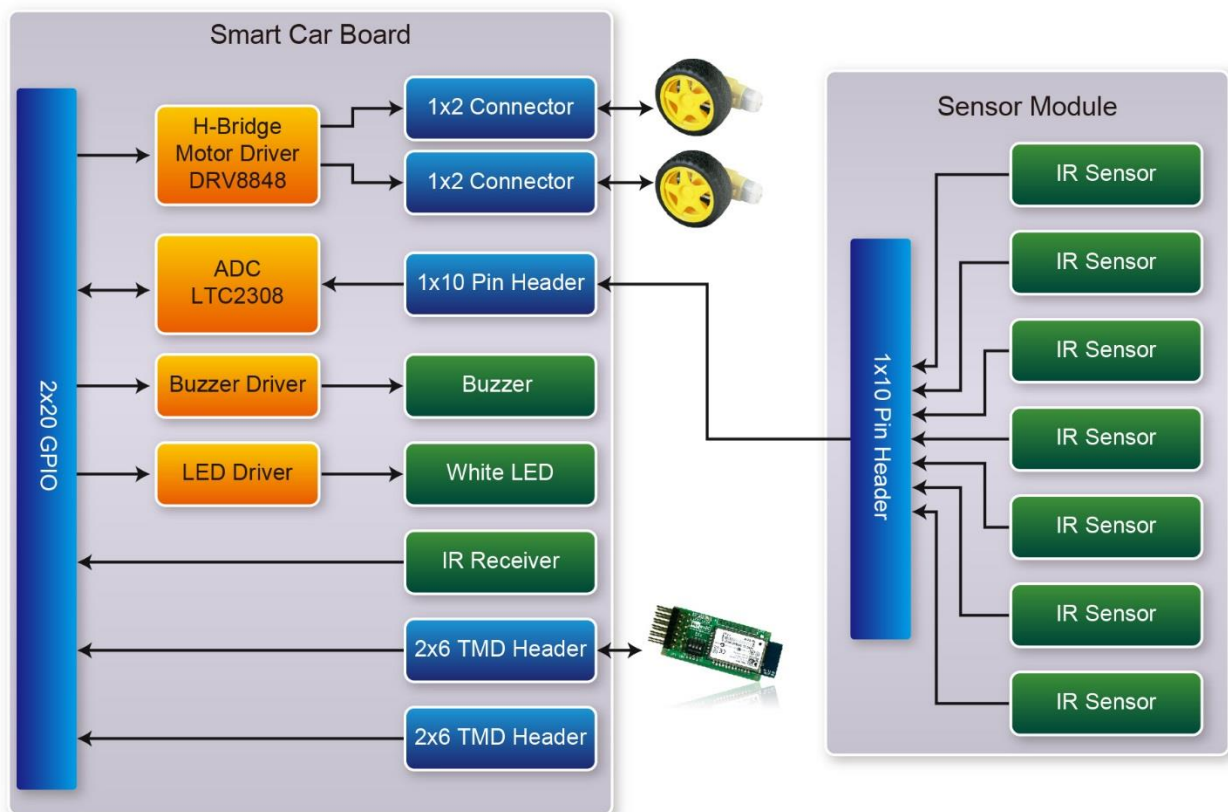

Figure 3-3 SCD Card and Sensor Module Block Diagram

Hereinafter, we described in detail for each section.

3.3.1 Power System

The SCD is equipped with Linear Technology company's Buck-Boost DC / DC Converter (LTC3112), as a stable power source, and supplied to DE0-Nano Development Board. The SCD provides a power control feature; the system can stop the power consumption when the system does not need to run constantly, this saves battery power. For basic power architecture please reference **Figure 3-4**.

Detailed information on using the LTC3113 is available on the manufacturer's website <http://www.linear.com/product/LTC3112>, or under the Datasheets\Power\ folder on the Kit System CD.

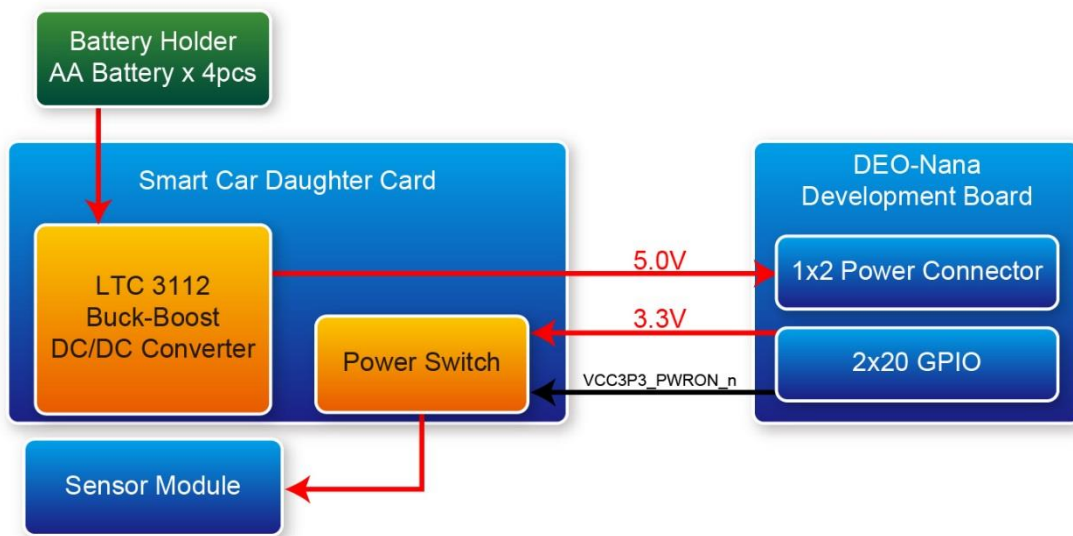

Figure 3-4 SCD Power System

Users can control VCC3P3_PWRON_n signal to save battery power. When the signal is High, the 3.3V power supply on the SCD will be turned OFF; when the signal is Low, SCD will be turned ON, and the 3.3V power supply, other devices will start running.

The **Figure 3-4** shows the connections between the GPIO and the power control. **Table 3-1** lists the pin assignment of the Power control interface; it is connected to the DE0-Nano GPIO0 pin assignment.

Table 3-1 Pin Assignment of 3.3V Power Control

| SCD Signal Name | GPIO Pin No. | FPGA Pin No. on GPIO 0 | Description | I/O Standard |
|-----------------|--------------|------------------------|--|--------------|
| VCC3P3_PWRON_n | 40 | PIN_B12 | SCD 3.3V Power Control signal. Low Active. | OUT, 3.3V |

3.3.2 Motor Driver

The SCD provides a dual H-bridge motor driver (DRV8848) made by Texas Instruments. This motor driver is for home appliances and other mechatronic applications. The device can be used to drive one or two DC motors, a bipolar stepper motor, or other applications. A simple PWM interface allows easy interfacing to controller circuits.

Detailed information on using the DRV8848 is available on the manufacturer's website <http://www.ti.com/product/DRV8848>, or under the Datasheets\Motor folder on the SCD System CD.

The **Figure 3-5** shows the Connections between the GPIO and Motor Driver. **Table 3-2** lists the pin assignment of the Motor Driver interface connected to the DE0-Nano GPIO 0.

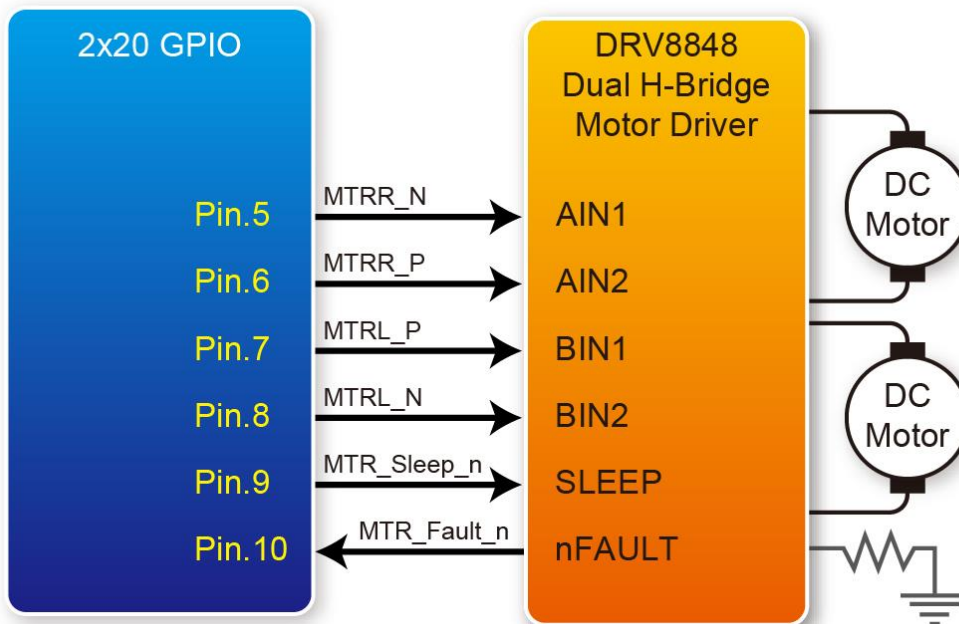

Figure 3-5 Connections between the GPIO and Motor Driver

Table 3-2 Pin assignment of Motor Driver interface

| SCD Signal Name | GPIO Pin No. | FPGA Pin No. on GPIO 0 | Description | I/O Standard |
|-----------------|--------------|------------------------|--|--------------|
| MTRR_N | 5 | PIN_A2 | Right Motor Negative signal. | OUT, 3.3V |
| MTRR_P | 6 | PIN_A3 | Right Motor Positive signal. | OUT, 3.3V |
| MTRL_P | 7 | PIN_B3 | Left Motor Positive signal. | OUT, 3.3V |
| MTRL_N | 8 | PIN_B4 | Left Motor Negative signal. | OUT, 3.3V |
| MTR_Sleep_n | 9 | PIN_A4 | Logic high to enable device logic low to enter low-power sleep mode | OUT, 3.3V |
| MTR_Fault_n | 10 | PIN_B5 | Pulled logic low with fault condition | IN, 3.3V |

The device integrates two H-bridges that use NMOS low-side drivers and PMOS high-side drivers and current sensor regulation circuitry. The DRV8848 can be powered with a supply range between 4 to 18 V and is capable of providing an output current to 1-A rms.

Table 3-3 shows the logic for the inputs of H-Bridge control.

Table 3-3 H-Bridge Control Signal

| MTRR_P | MTRR_N | MTRR_OUT_Ap | MTRR_OUT_An | Function (DC Motor) |
|--------|--------|-------------|-------------|---------------------|
| MTRL_P | MTRL_N | MTRL_OUT_Bp | MTRL_OUT_Bn | |
| 0 | 0 | Z | Z | Coast (fast decay) |
| 0 | 1 | L | H | Reverse |
| 1 | 0 | H | L | Forward |
| 1 | 1 | L | L | Brake (slow decay) |

3.3.3 ADC LTC2308

The SCD has an analog-to-digital converter (LTC2308) made by Linear Technology.

The LTC2308 is a low noise, 500ksps, 8-channel, 12-bit ADC with a SPI/MICROWIRE compatible serial interface. This ADC includes an internal reference and a fully differential sample-and-hold circuit to reduce common mode noise. The internal conversion clock allows the external serial output data clock (SCK) to operate at any frequency up to 40MHz. The ADC provides a 4-wire SPI compatible serial interface that is connected to a 2x20 GPIO header, as show in **Figure 3-6**.

It can be configured to accept eight input signals at inputs ADC_IN0 through ADC_IN7. These eight input signals are connected to a 1x10 header, as shown in **Figure 3-6**.

Wherein, ADC_IN0 ~ ADC_IN6 is sensing results from the reflection-type infrared sensor, and the other ADC_IN7 from the battery voltage divider, is a 1:4 partial pressure, the user can understand the state of the battery through the ADC_IN7

More information about the A/D converter chip is available in its datasheet. It can be found on manufacturer's website <http://www.linear.com/product/LTC2308>, or in the directory \Datasheet\ADC on the SCD System CD.

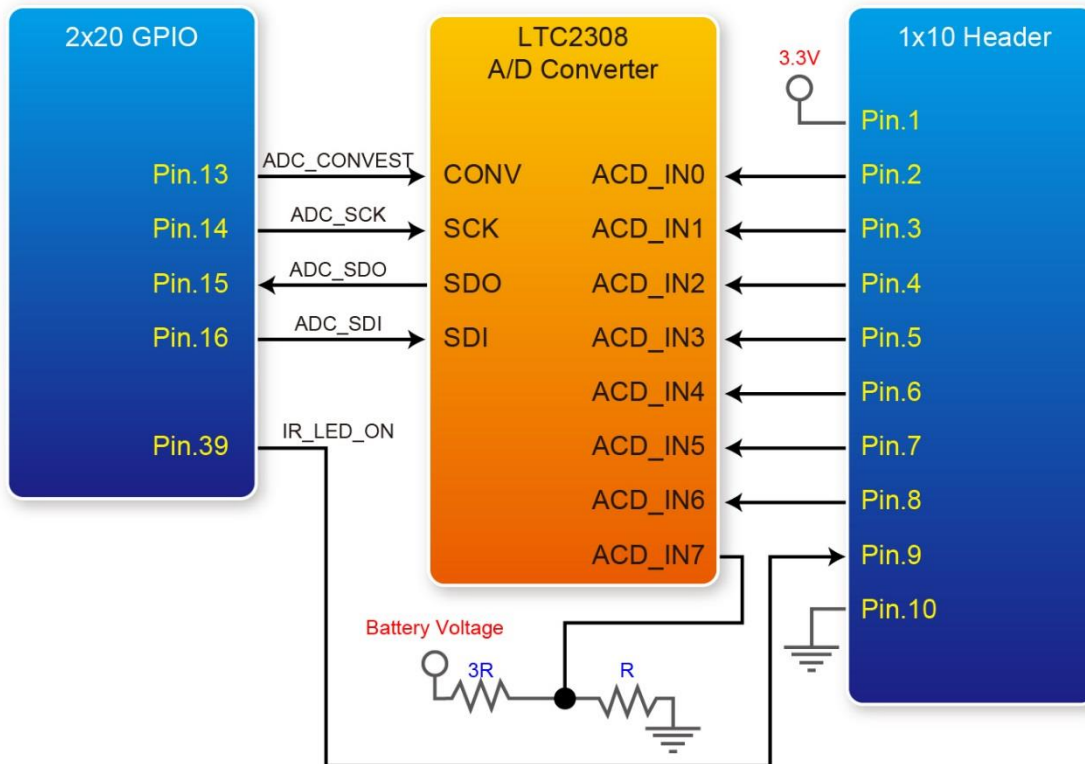

Figure 3-6 Connections between the GPIO, A/D Converter and 1x10 Header

To save power, the 1x10 header with an LED power switch control signals in pin.9, we can turn off the switch when the IR LED is not in use. The signal name is IR_LED_ON and high active.

Table 3-4 lists the pin assignment of SPI interface connected to the DE0-Nano GPIO0, Include Sensor Module power control signal.

Table 3-4 Pin assignment of ADC 4-Wire SPI interface and Power control

| SCD Signal Name | GPIO Pin No. | FPGA Pin No. on GPIO 0 | Description | I/O Standard |
|-----------------|--------------|------------------------|---|--------------|
| ADC_CONVST | 11 | PIN_A5 | Right Motor Negative signal. | OUT, 3.3V |
| ADC_SCK | 12 | PIN_D5 | Right Motor Positive signal. | OUT, 3.3V |
| ADC_SDO | 13 | PIN_B6 | Left Motor Positive signal. | IN, 3.3V |
| ADC_SDI | 14 | PIN_A6 | Left Motor Negative signal. | OUT, 3.3V |
| IR_LED_ON | 39 | PIN_D12 | IR LED Power Control signal. Logic high to turn on IR LED power. | OUT, 3.3V |

3.3.4 User Buzzer and LED

SCD placed one buzzer and two LED lights on the card; which is a device that allows the user to control the buzzer and LED lights. These devices are using the common emitter circuit to increase the output current.

When the user wants to turn on the LED light, adjust the signal to high and the LED lights will light up.

If users want the buzzer to play a sound; you need to generate a frequency output to the buzzer. Please note that the required frequency falls between 20Hz ~ 20KHz.

The Figure 3-7 shows the Connections between the GPIO and LED / Buzzer Driver. **Table 3-5** lists the pin assignment of LED / Buzzer Driver connected to the DE0-Nano GPIO

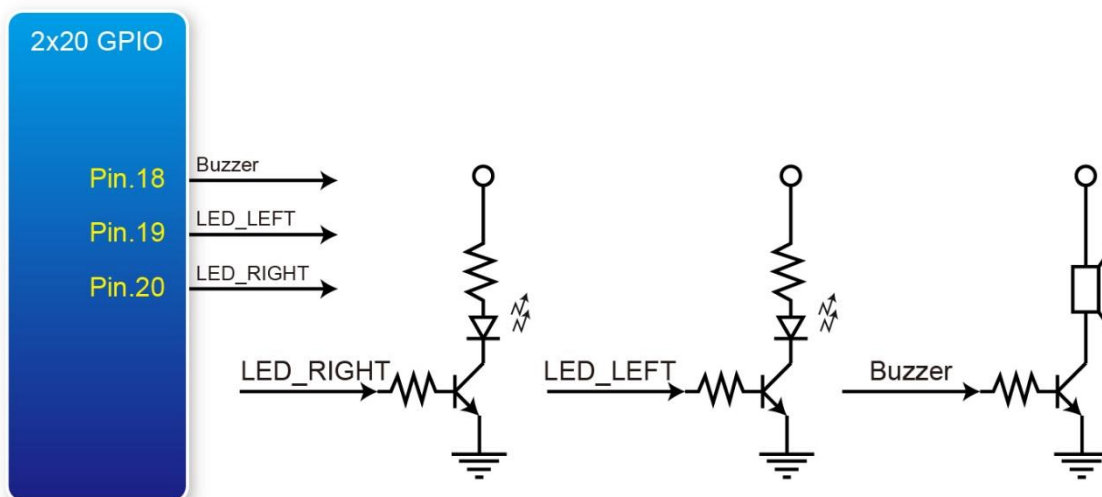

Figure 3-7 Connections between the GPIO and LED / Buzzer

Table 3-5 Pin assignment of LED / Buzzer

| SCD Signal Name | GPIO Pin No. | FPGA Pin No. on GPIO 0 | Description | I/O Standard |
|-----------------|--------------|------------------------|--------------------|--------------|
| Buzzer | 18 | PIN_D6 | Buzzer wave signal | OUT, 3.3V |
| LED_LEFT | 19 | PIN_A7 | Left LED signal. | OUT, 3.3V |
| LED_RIGHT | 20 | PIN_C6 | Right LED signal. | OUT, 3.3V |

3.3.5 IR Receiver

The SCD provides an infrared remote-control receiver Module (model: IRM-V538N7/TR1), whose datasheet is offered in the directory \Datasheet\IR_Receiver on the SCD System CD. Note that for this all-in-one receiver module, it is only compatible with the 38KHz carrier Standard, with a maximum data rate of about 4kbps for its product information. The accompanied remote controller with an encoding chip of uPD6121G is very suitable of generating expected infrared signals.

Figure 3-8 shows the related schematic of the IR receiver, and the pin assignments of the associated interface connected to DE0-Nnao GPIO0 are listed in **Table 3-6**.

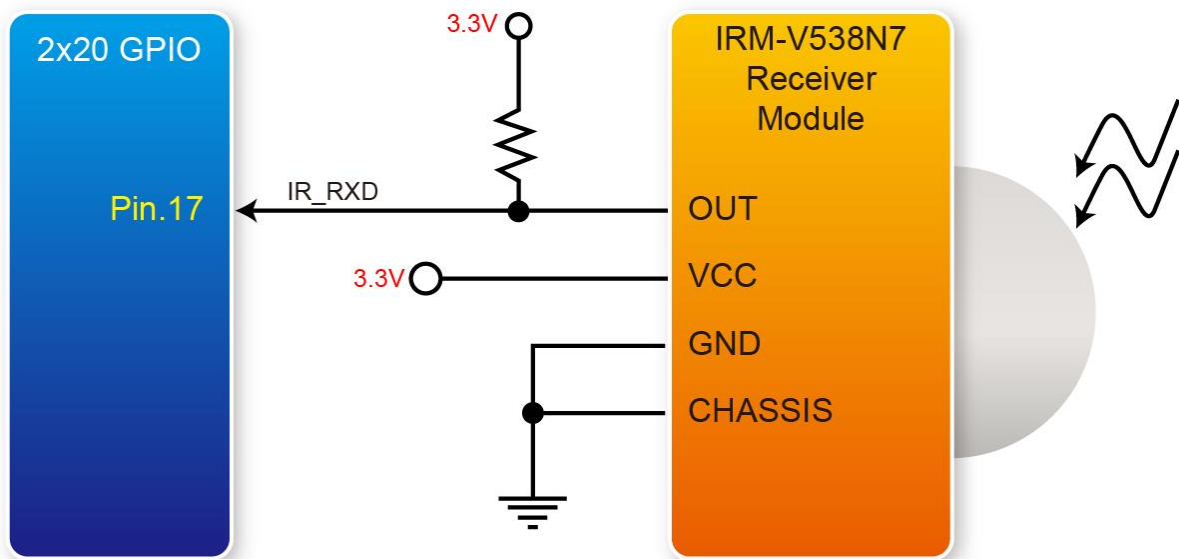

Figure 3-8 Connection between the GPIO and IR receiver module

Table 3-6 Pin assignment of IR Receiver Module

| SCD Signal Name | GPIO Pin No. | FPGA Pin No. on GPIO 0 | Description | I/O Standard |
|-----------------|--------------|------------------------|---------------------|--------------|
| IR_RXD | 17 | PIN_B7 | IR Receiver signal. | IN, 3.3V |

3.3.6 TMD Header

The board has one 2x6 TMD (Terasic Mini Digital) expansion header. The TMD header has 8 digital GPIO user pins connected to the 2x20 GPIO header, two 3.3V power pins and two ground pins. There are two Transient Voltage Suppressor diode arrays used to implement ESD protection for 8 GPIO user pins.

Figure 3-9 shows the connection between the TMD header and the 2x20 GPIO header.

Table 3-7 shows the pin assignment of two 2x6 TMD headers.

Table 3-7 Pin assignment of two 2x6 TMD Header

| SCD Signal Name | GPIO Pin No. | FPGA Pin No. on GPIO 0 | Description | I/O Standard |
|-----------------|--------------|------------------------|--------------------------|--------------|
| TMD0_D0 | 21 | PIN_C8 | TMD0 GPIO Connection [0] | INOUT, 3.3V |
| TMD0_D1 | 22 | PIN_E7 | TMD0 GPIO Connection [1] | INOUT, 3.3V |
| TMD0_D2 | 23 | PIN_E8 | TMD0 GPIO Connection [2] | INOUT, 3.3V |
| TMD0_D3 | 24 | PIN_F9 | TMD0 GPIO Connection [3] | INOUT, 3.3V |
| TMD0_D4 | 25 | PIN_E6 | TMD0 GPIO Connection [4] | INOUT, 3.3V |
| TMD0_D5 | 26 | PIN_D8 | TMD0 GPIO Connection [5] | INOUT, 3.3V |
| TMD0_D6 | 27 | PIN_F8 | TMD0 GPIO Connection [6] | INOUT, 3.3V |
| TMD0_D7 | 28 | PIN_E9 | TMD0 GPIO Connection [7] | INOUT, 3.3V |
| TMD1_D0 | 31 | PIN_C9 | TMD1 GPIO Connection [0] | INOUT, 3.3V |
| TMD1_D1 | 32 | PIN_E11 | TMD1 GPIO Connection [1] | INOUT, 3.3V |
| TMD1_D2 | 33 | PIN_C11 | TMD1 GPIO Connection [2] | INOUT, 3.3V |
| TMD1_D3 | 34 | PIN_A12 | TMD1 GPIO Connection [3] | INOUT, 3.3V |
| TMD1_D4 | 35 | PIN_D9 | TMD1 GPIO Connection [4] | INOUT, 3.3V |
| TMD1_D5 | 36 | PIN_E10 | TMD1 GPIO Connection [5] | INOUT, 3.3V |
| TMD1_D6 | 37 | PIN_B11 | TMD1 GPIO Connection [6] | INOUT, 3.3V |
| TMD1_D7 | 38 | PIN_D11 | TMD1 GPIO Connection [7] | INOUT, 3.3V |

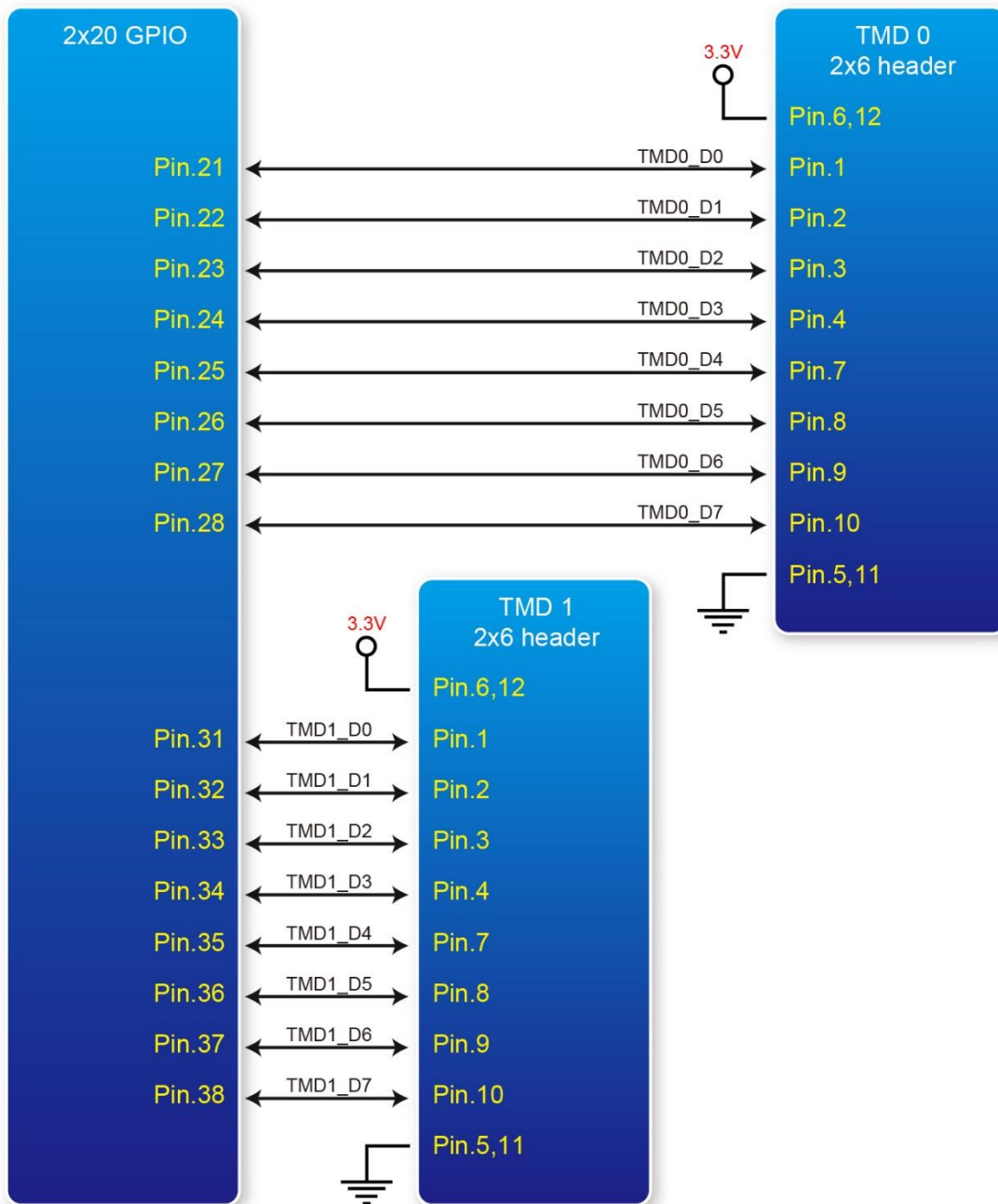

Figure 3-9 Connections between the 2x6 TMD header and 2x20 GPIO header

X-ON Electronics

Largest Supplier of Electrical and Electronic Components

Click to view similar products for [Programmable Logic IC Development Tools](#) category:

Click to view products by [Terasic Technologies](#) manufacturer:

Other Similar products are found below :

[DK-DEV-5SGXEA7N](#) [88980182](#) [DEV-17526](#) [DEV-17514](#) [LCMXO3L-SMA-EVN](#) [471-014](#) [80-001005](#) [iCE40UP5K-MDP-EVN](#)
[ALTNITROC5GX](#) [471-015](#) [Hinj](#) [SnoMakrR10](#) [DK-DEV-1SDX-P-A](#) [DK-DEV-1SDX-P-0ES](#) [DK-DEV-1SGX-L-A](#) [DK-DEV-1SMC-H-A](#)
[DK-DEV-1SMX-H-0ES](#) [DK-DEV-1SMX-H-A](#) [DK-DEV-4CGX150N](#) [DK-DEV-5CGTD9N](#) [DK-DEV-5CSXC6N](#) [DK-MAXII-1270N](#) [DK-](#)
[SI-1SGX-H-A](#) [DK-SI-1STX-E-0ES](#) [DK-SI-1STX-E-A](#) [DK-SI-5SGXEA7N](#) [EK-10M08E144](#) [ATF15XX-DK3-U](#) [SLG46824V-DIP](#)
[SLG46826V-DIP](#) [240-114-1](#) [6003-410-017](#) [ICE40UP5K-B-EVN](#) [DK-SOC-1SSX-L-D](#) [ICE5LP4K-WDEV-EVN](#) [L-ASC-BRIDGE-EVN](#)
[LC4256ZE-B-EVN](#) [LCMXO2-7000HE-B-EVN](#) [LCMXO3D-9400HC-B-EVN](#) [LCMXO3L-6900C-S-EVN](#) [LF-81AGG-EVN](#) [LFE3-MEZZ-](#)
[EVN](#) [LIF-MD6000-ML-EVN](#) [LPTM-ASC-B-EVN](#) [M2S-HELLO-FPGA-KIT](#) [VIDEO-DC-USXGMII](#) [12GSDIFMCCD](#) [SFP+X4FMCCD](#)
[NAE-CW305-04-7A100-0.10-X](#) [NOVPEK CVLite](#)