

2N7001T Single-Bit Dual-Supply Buffered Voltage Signal Converter

1 Features

- Up and down translation across 1.65 V to 3.6 V
- Operating temperature: -40°C to $+125^{\circ}\text{C}$
- Maximum quiescent current ($I_{\text{CCA}} + I_{\text{CCB}}$) of 14 μA (125°C maximum)
- Up to 100 Mbps support across the full supply range
- V_{CC} isolation feature
 - If either V_{CC} input is below 100 mV, the output becomes high-impedance
- I_{off} supports partial-power-down mode operation
- Latch-up performance exceeds 100 mA per JESD 78, Class II
- ESD protection exceeds JESD 22
 - 2000-V Human body model
 - 1000-V Charged-device model

2 Applications

- MCU/FPGA/processor GPIO translation
- Communications modules to processor translation
- Push-pull I/O buffering

3 Description

The 2N7001T is a single-bit buffered voltage signal converter that uses two separate configurable power-supply rails to up or down translate a unidirectional signal. The device is operational with both V_{CCA} and V_{CCB} supplies down to 1.65 V and up to 3.60 V. V_{CCA} defines the input threshold voltage on the A input. V_{CCB} defines the output drive voltage on the B output.

This device is fully specified for partial-power-down applications using the I_{off} current. The I_{off} protection circuitry ensures that no excessive current is drawn from or to an input, output, or combined I/O that is biased to a specific voltage while the device is powered down.

The V_{CC} isolation feature ensures that if either V_{CCA} or V_{CCB} is less than 100 mV, the output port (B) enters a high-impedance state.

Device Information⁽¹⁾

PART NUMBER	PACKAGE	BODY SIZE (NOM)
2N7001TDCK	SC70 (5)	2.00 mm × 1.25 mm
2N7001TDPW	X2SON (5)	0.80 mm × 0.80 mm

(1) For all available packages, see the orderable addendum at the end of the data sheet.

Block Diagram and Pin Configuration

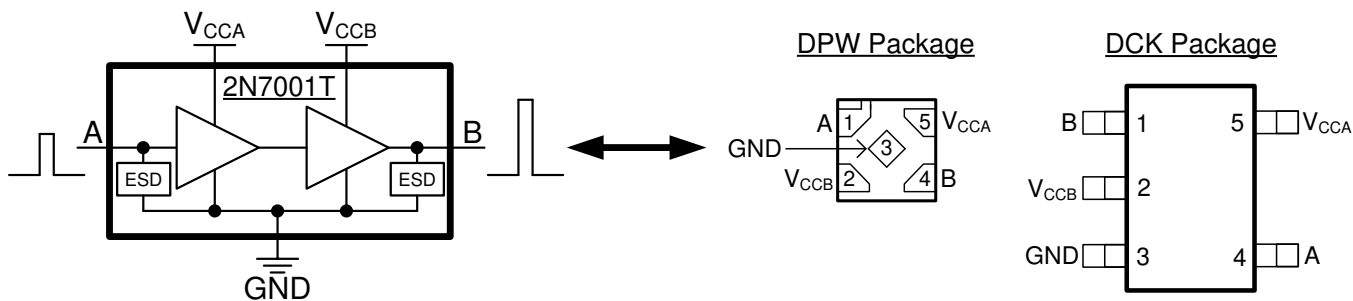

Table of Contents

1 Features	1	8.2 Functional Block Diagram	9
2 Applications	1	8.3 Feature Description.....	9
3 Description	1	8.4 Device Functional Modes.....	10
4 Revision History	2	9 Application and Implementation	11
5 Pin Configuration and Functions	3	9.1 Application Information.....	11
6 Specifications	4	9.2 Typical Applications	11
6.1 Absolute Maximum Ratings	4	10 Power Supply Recommendations	13
6.2 ESD Ratings.....	4	11 Layout	13
6.3 Recommended Operating Conditions	5	11.1 Layout Guidelines	13
6.4 Thermal Information	5	11.2 Layout Example	13
6.5 Electrical Characteristics.....	6	12 Device and Documentation Support	14
6.6 Switching Characteristics	6	12.1 Documentation Support	14
6.7 Operating Characteristics.....	6	12.2 Receiving Notification of Documentation Updates	14
6.8 Typical Characteristics.....	7	12.3 Support Resources	14
7 Parameter Measurement Information	8	12.4 Trademarks	14
7.1 Load Circuit and Voltage Waveforms	8	12.5 Electrostatic Discharge Caution.....	14
8 Detailed Description	9	12.6 Glossary	14
8.1 Overview	9	13 Mechanical, Packaging, and Orderable Information	14

4 Revision History

NOTE: Page numbers for previous revisions may differ from page numbers in the current version.

Changes from Revision A (June 2018) to Revision B	Page
• Changed V_{ILMAX} from $V_{CCA} \times 0.65$ to $V_{CCA} \times 0.35$	5

Changes from Original (May 2018) to Revision A	Page
• Changed from Advanced Information to Production Data	1

5 Pin Configuration and Functions

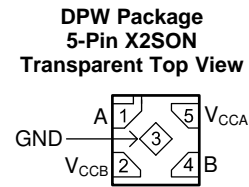
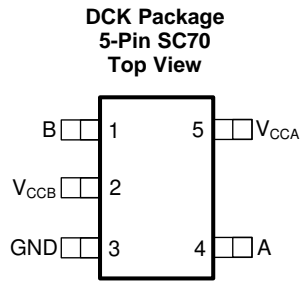

Pin Functions

PIN			TYPE	DESCRIPTION
NAME	DCK	DPW		
A	4	1	I	Data Input. This pin is referenced to V_{CCA} .
B	1	4	O	Data Output. This pin is referenced to V_{CCB} .
V_{CCA}	5	5	—	Input Supply voltage. $1.65V \leq V_{CCA} \leq 3.6V$.
V_{CCB}	2	2	—	Output Supply voltage. $1.65V \leq V_{CCB} \leq 3.6V$.
GND	3	3	—	Ground

6 Specifications

6.1 Absolute Maximum Ratings

over operating free-air temperature range (unless otherwise noted)⁽¹⁾

		MIN	MAX	UNIT	
V _{CCA}	Supply voltage, A Port	-0.5	4.2	V	
V _{CCB}	Supply voltage, B Port	-0.5	4.2	V	
V _I	Input voltage ⁽²⁾	-0.5	4.2	V	
V _O	Voltage applied to the output in the high-impedance or power-off state ⁽²⁾	-0.5	4.2	V	
V _O	Voltage applied to the output in the high or low state ⁽²⁾⁽³⁾	-0.5	V _{CCB} + 0.2	V	
I _{IK}	Input clamp current	V _I < 0		-50	mA
I _{OK}	Output clamp current	V _O < 0		-50	mA
I _O	Continuous output current	-50	50	mA	
I _O	Continuous current through V _{CCB} or GND	-50	50	mA	
I _O	Continuous current through V _{CCA}	-10	10	mA	
T _J	Operating junction temperature	-40	150	°C	
T _{stg}	Storage temperature	-65	150	°C	

- (1) Stresses beyond those listed under the *Absolute Maximum Ratings* table may cause permanent damage to the device. These are stress ratings only, and functional operation of the device at these or any other conditions beyond those indicated under *Recommended Operating Conditions* is not implied. Exposure to absolute-maximum-rated conditions for extended periods may affect device reliability.
- (2) The input negative-voltage and output voltage ratings may be exceeded if the input and output current ratings are observed.
- (3) The output positive-voltage rating may be exceeded up to 4.2 V maximum if the output current ratings are observed.

6.2 ESD Ratings

		VALUE	UNIT
V _(ESD)	Electrostatic discharge	Human-body model (HBM), per ANSI/ESDA/JEDEC JS-001 ⁽¹⁾	±2000
		Charged-device model (CDM), per JEDEC specification JESD22-C101 ⁽²⁾	±1000

- (1) JEDEC document JEP155 states that 500-V HBM allows safe manufacturing with a standard ESD control process.
- (2) JEDEC document JEP157 states that 250-V CDM allows safe manufacturing with a standard ESD control process.

6.3 Recommended Operating Conditions

over operating free-air temperature range (unless otherwise noted)

		MIN	MAX	UNIT
V _{CCA}	Supply voltage, V _{CCA}	1.65	3.6	V
V _{CCB}	Supply voltage, V _{CCB}	1.65	3.6	V
V _{IH}	High-level input voltage	V _{CCA} = 1.65 V - 1.95 V	V _{CCA} × 0.65	V
		V _{CCA} = 2.30 V - 2.70 V	1.60	
		V _{CCA} = 3.00 V - 3.60 V	2.00	
V _{IL}	Low-level input voltage	V _{CCA} = 1.65 V - 1.95 V	V _{CCA} × 0.35	V
		V _{CCA} = 2.30 V - 2.70 V	0.70	
		V _{CCA} = 3.00 V - 3.60 V	0.80	
V _I	Input voltage	0	3.6	V
V _O	Output voltage	Active state	0	V _{CCB}
		Tri-state	0	3.6
Δt/Δv	Input transition rise or fall rate		100	ns/V
T _A	Operating free-air temperature	-40	125	°C

6.4 Thermal Information

THERMAL METRIC ⁽¹⁾		2N7001T		UNIT
		DCK (SC70)	DPW (X2SON)	
		5 PINS	5 PINS	
R _{θJA}	Junction-to-ambient thermal resistance	253.5	462.7	°C/W
R _{θJC(top)}	Junction-to-case (top) thermal resistance	162.6	227.7	°C/W
R _{θJB}	Junction-to-board thermal resistance	140.6	326.5	°C/W
Ψ _{JT}	Junction-to-top characterization parameter	69.8	33.8	°C/W
Ψ _{JB}	Junction-to-board characterization parameter	139.7	325.1	°C/W

(1) For more information about traditional and new thermal metrics, see the [Semiconductor and IC Package Thermal Metrics](#) application report.

6.5 Electrical Characteristics

Over recommended operating free-air temperature range (unless otherwise noted)

PARAMETER	TEST CONDITIONS	V _{CCA}	V _{CCB}	MIN	TYP ⁽¹⁾	MAX	UNIT
V _{OH} High-level output voltage	V _I = V _{IH}	I _{OH} = -100 μA	1.65 V - 3.6 V	1.65 V - 3.6 V	V _{CCB} - 0.1		V
		I _{OH} = -8 mA	1.65 V	1.65 V	1.2		
		I _{OH} = -9 mA	2.3 V	2.3 V	1.75		
		I _{OH} = -12 mA	3 V	3 V	2.3		
V _{OL} Low-level output voltage	V _I = V _{IL}	I _{OL} = 100 μA	1.65 V - 3.6 V	1.65 V - 3.6 V	0.1		V
		I _{OL} = 8 mA	1.65 V	1.65 V	0.45		
		I _{OL} = 9 mA	2.3 V	2.3 V	0.55		
		I _{OL} = 12 mA	3 V	3 V	0.7		
I _{off} Partial power down current	V _I or V _O = 0 V - 3.6 V	0 V	0 V - 3.6 V	-8		8	μA
	V _I or V _O = 0 V - 3.6 V	0 V - 3.6 V	0 V	-8		8	
I _{CCA} V _{CCA} supply current	V _I = V _{CCA} or GND, I _O = 0 mA	1.65 V - 3.6 V	1.65 V - 3.6 V			8	μA
		0 V	3.6 V	-8			
		3.6 V	0 V			8	
I _{CCB} V _{CCB} supply current	V _I = V _{CCB} or GND, I _O = 0 mA	1.65 V - 3.6 V	1.65 V - 3.6 V			8	μA
		0 V	3.6 V			8	
		3.6 V	0 V	-8			
I _{CCA} + I _{CCB} Combined supply current	V _I = V _{CCB} or GND, I _O = 0 mA	1.65 V - 3.6 V	1.65 V - 3.6 V			14	μA
C _I Input capacitance	V _I = 1.65 V DC + 1MHz -16 dBm sine wave	3.3 V	0 V		2		pF
C _O Output capacitance	V _I = 1.65 V DC + 1MHz -16 dBm sine wave	0 V	3.3 V		4		pF

 (1) All typical values are for T_A = 25°C

6.6 Switching Characteristics

over operating free-air temperature range (unless otherwise noted)

PARAMETER	TEST CONDITIONS	MIN	MAX	UNIT	
t _{pd} Propagation Delay	V _{CCA} = 1.80 ± 0.15 V	V _{CCB} = 1.80 ± 0.15 V	0.5	20	ns
		V _{CCB} = 2.50 ± 0.20 V	0.5	17	
		V _{CCB} = 3.30 ± 0.30 V	0.5	14	
	V _{CCA} = 2.50 ± 0.20 V	V _{CCB} = 1.80 ± 0.15 V	0.5	18	
		V _{CCB} = 2.50 ± 0.20 V	0.5	15	
		V _{CCB} = 3.30 ± 0.30 V	0.5	12	
	V _{CCA} = 3.30 ± 0.30 V	V _{CCB} = 1.80 ± 0.15 V	0.5	16	
		V _{CCB} = 2.50 ± 0.20 V	0.5	13	
		V _{CCB} = 3.30 ± 0.30 V	0.5	10	

6.7 Operating Characteristics

 T_A = 25°C

PARAMETER	TEST CONDITIONS	MIN	TYP	MAX	UNIT
C _{pdA} Power dissipation capacitance - Port A	I _O = 0 mA C _L = 0 pF, f = 1 MHz, t _r = t _f = 1 ns	V _{CCA} = V _{CCB} = 1.8 V	1		pF
		V _{CCA} = V _{CCB} = 2.5 V	1.3		
		V _{CCA} = V _{CCB} = 3.3 V	1.8		
C _{pdB} Power dissipation capacitance - B Port	I _O = 0 mA C _L = 0 pF, f = 1 MHz, t _r = t _f = 1 ns	V _{CCA} = V _{CCB} = 1.8 V	12		pF
		V _{CCA} = V _{CCB} = 2.5 V	15		
		V _{CCA} = V _{CCB} = 3.3 V	18		

6.8 Typical Characteristics

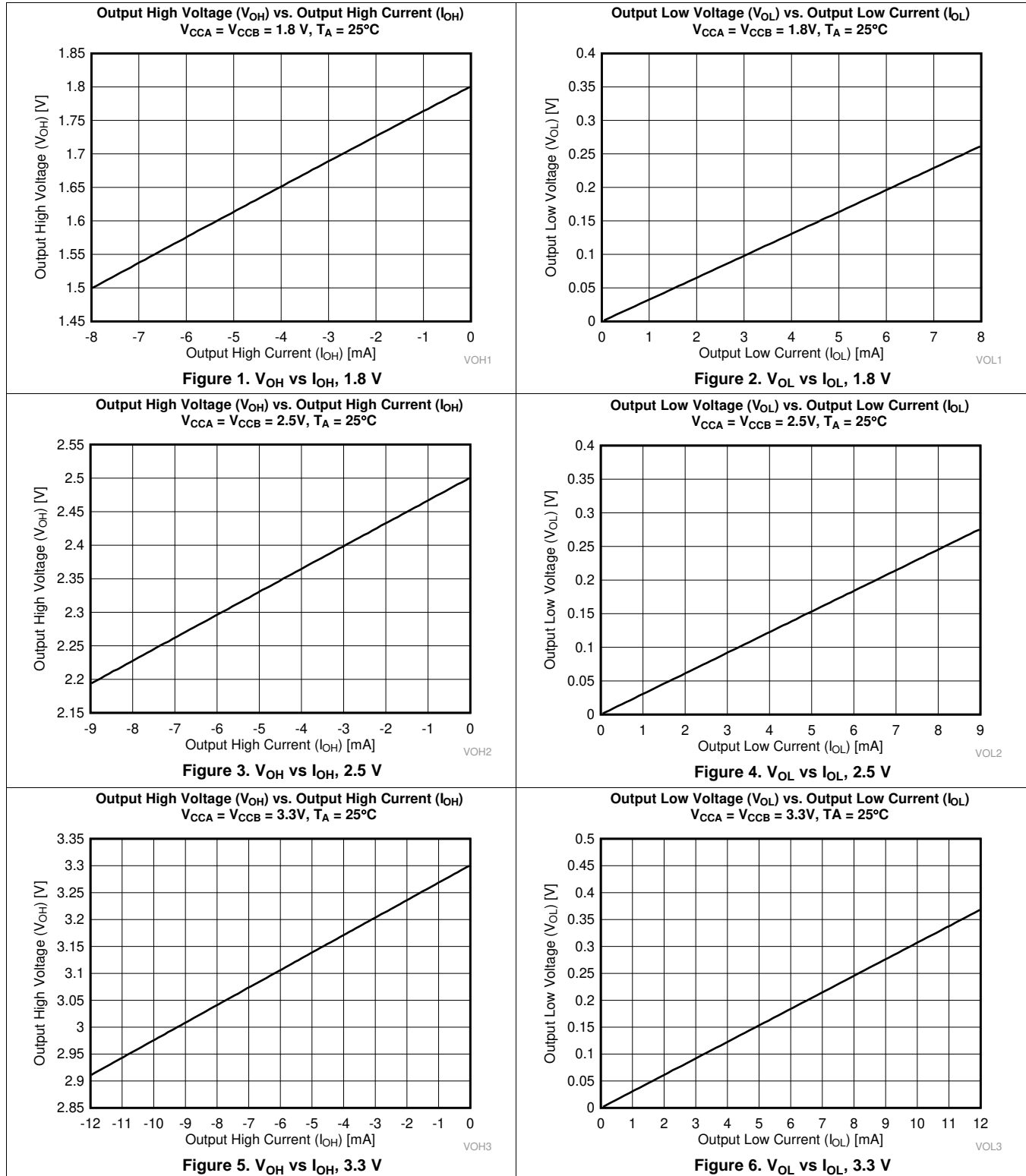

7 Parameter Measurement Information

7.1 Load Circuit and Voltage Waveforms

Unless otherwise noted, all input pulses are supplied by generators having the following characteristics:

- $f = 1 \text{ MHz}$
- $Z_O = 50 \Omega$
- $dv/dt \leq 1 \text{ ns/V}$

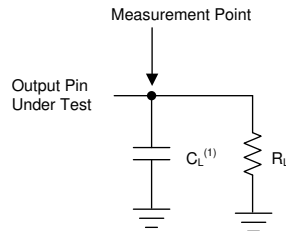

(1) C_L includes probe and jig capacitance.

Figure 7. Load Circuit

Table 1. Load Circuit Conditions

Parameter	V_{CC}	R_L	C_L
t_{pd} Propagation (delay) time	1.65 V – 3.6 V	2 k Ω	15 pF

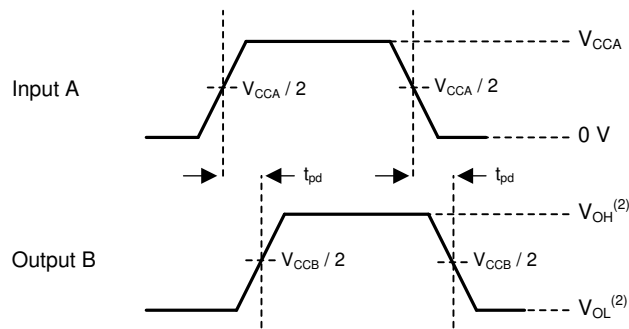

(1) V_{CCI} is the supply pin associated with the input port.

(2) V_{OH} and V_{OL} are typical output voltage levels that occur with specified R_L and C_L .

Figure 8. Propagation Delay

8 Detailed Description

8.1 Overview

The 2N7001T is a single-bit dual-supply buffered voltage signal converter that can be used to up or down-translate a single unidirectional signal. The device is operational with both V_{CCA} and V_{CCB} supplies down to 1.65 V and up to 3.60 V. V_{CCA} defines the input threshold voltage on the A input while V_{CCB} defines the output voltage on the B output.

8.2 Functional Block Diagram

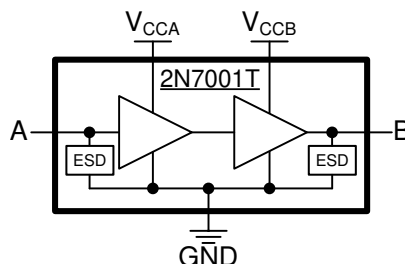

8.3 Feature Description

8.3.1 Up-Translation or Down-Translation from 1.65 V to 3.60 V

The V_{CCA} and V_{CCB} pins can both be supplied by a voltage range from 1.65 V to 3.6 V. This voltage range makes the device suitable for translating between any of the voltage nodes (1.8 V, 2.5 V, and 3.3 V).

8.3.2 Balanced CMOS Push-Pull Outputs

A balanced output allows the device to sink and source similar currents. The drive capability of this device may create fast edges into light loads, so routing and load conditions should be considered to prevent ringing. Additionally, the outputs of this device are capable of driving larger currents than the device can sustain without being damaged. It is important for the output power of the device to be limited to avoid damage due to over-current. The electrical and thermal limits defined in the [Absolute Maximum Ratings](#) must be followed at all times.

8.3.3 Standard CMOS Inputs

Standard CMOS inputs are high impedance and are typically modeled as a resistor in parallel with the input capacitance shown in the [Electrical Characteristics](#). The worst case resistance is calculated with the maximum input voltage, shown in the [Absolute Maximum Ratings](#), and the maximum input leakage current, shown in the [Electrical Characteristics](#), using Ohm's law ($R = V \div I$).

Signals applied to the inputs need to have fast edge rates, as defined by $\Delta t/\Delta v$ in the [Recommended Operating Conditions](#) to avoid excessive current consumption and oscillations. If a slow or noisy input signal is required, a device with a Schmitt-trigger input should be used to condition the input signal prior to the standard CMOS input.

Feature Description (continued)

8.3.4 Negative Clamping Diodes

The inputs and outputs to this device have negative clamping diodes as shown in [Figure 9](#).

CAUTION

Voltages beyond the values specified in the [Absolute Maximum Ratings](#) table can cause damage to the device. The input negative-voltage and output voltage ratings may be exceeded if the input and output clamp-current ratings are observed.

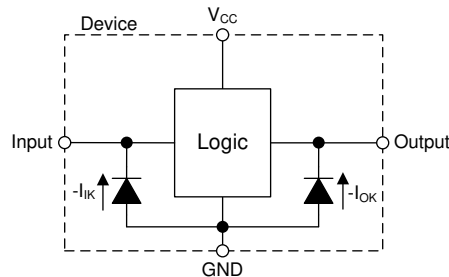

Figure 9. Electrical Placement of Clamping Diodes for Each Input and Output

8.3.5 Partial Power Down (I_{off})

The inputs and outputs for this device enter a high-impedance state when the supply voltage is 0 V. The maximum leakage into or out of any input pin or output pin on the device is specified by I_{off} in the [Electrical Characteristics](#).

8.3.6 Over-voltage Tolerant Inputs

Input signals to this device can be driven above the input supply voltage (V_{CCA}), as long as they remain below the maximum input voltage value specified in the [Recommended Operating Conditions](#).

8.4 Device Functional Modes

[Table 2](#) lists the functional modes of the 2N7001T device.

Table 2. Function Table

INPUT	OUTPUT
L (Referenced to V_{CCA})	L (Referenced to V_{CCB})
H (Referenced to V_{CCA})	H (Referenced to V_{CCB})

9 Application and Implementation

NOTE

Information in the following applications sections is not part of the TI component specification, and TI does not warrant its accuracy or completeness. TI's customers are responsible for determining suitability of components for their purposes. Customers should validate and test their design implementation to confirm system functionality.

9.1 Application Information

The 2N7001T device can be used in level-translation applications for interfacing between devices or systems that are operating at different interface voltages.

9.2 Typical Applications

9.2.1 Processor Error Up Translation

Figure 10 shows an example of the 2N7001T being used in a unidirectional logic level-shifting application.

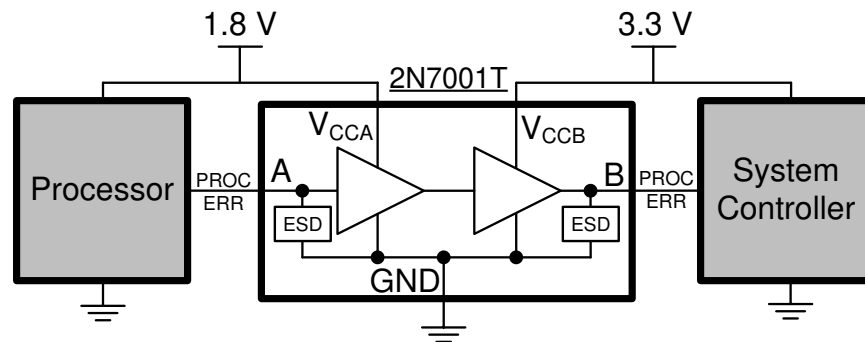

Figure 10. Processor Error Up Translation Application

9.2.1.1 Design Requirements

For this design example, use the parameters shown in Table 3.

Table 3. Design Parameters

DESIGN PARAMETER	EXAMPLE VALUE
Input voltage supply	1.8 V
Output voltage supply	3.3 V

9.2.1.2 Detailed Design Procedure

To begin the design process, determine the following:

- Input voltage range
 - The supply voltage of the upstream device (device that is driving input pin A) will determine the appropriate input voltage range. For a valid logic-high, the value must exceed the high-level input voltage (V_{IH}) of the input port. For a valid logic low the value must be less than the low-level input voltage (V_{IL}) of the input port.
- Output voltage range
 - The supply voltage of the downstream device (device that output pin B is driving) will determine the appropriate output voltage range.

9.2.1.3 Application Curve

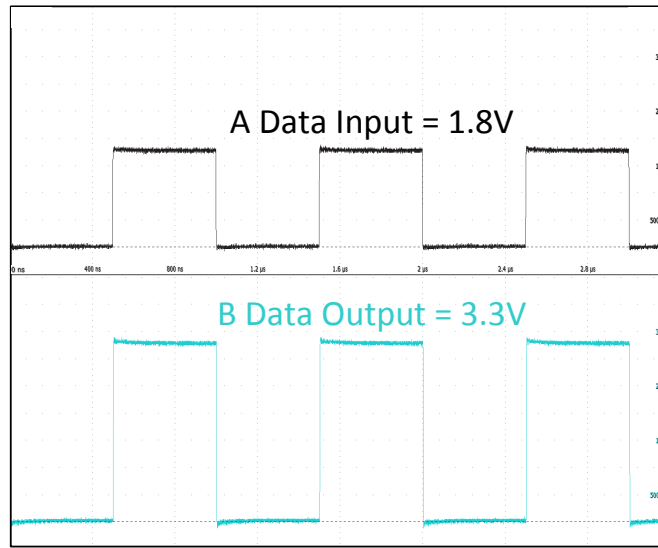

Figure 11. Up Translation (1.8 V to 3.3 V) at 1 MHz

9.2.2 Discrete FET Translation Replacement

The 2N7001T device is an excellent option for replacing discrete translators, as shown in Figure 12, and has the following benefits regarding discrete translation implementations:

- A single device vs a four component solution
- Minimized implementation size
- Lower power consumption
- V_{CC} isolation feature
- Higher data rates
- Integrated ESD protection
- Improved glitch performance

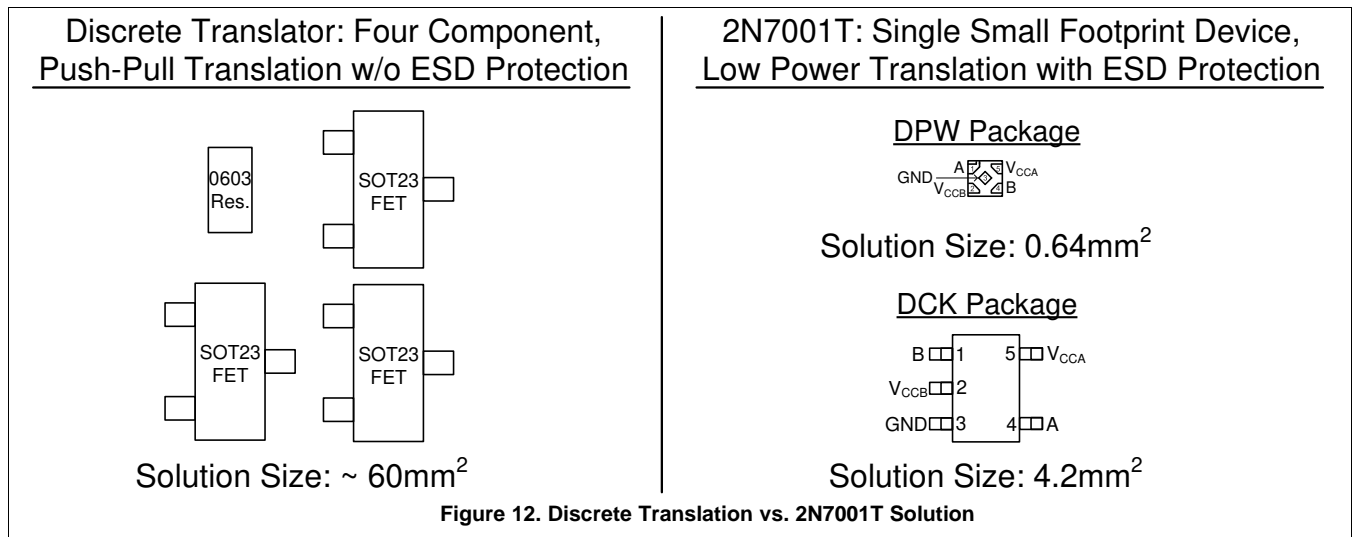

Figure 12. Discrete Translation vs. 2N7001T Solution

10 Power Supply Recommendations

The 2N7001T device uses two separate configurable power-supply rails, V_{CCA} and V_{CCB} . The V_{CCA} and V_{CCB} power-supply rails accept any supply voltage that range from 1.65 V to 3.6 V. The A input and B output are referenced to V_{CCA} and V_{CCB} respectively allowing up or down translation among the 1.8-V, 2.5-V, and 3.3-V voltage nodes. A 0.1 μ F bypass capacitor is recommended on all V_{CC} pins.

Always apply a ground reference to the GND pin first. However, there are no additional requirement for power supply sequencing.

11 Layout

11.1 Layout Guidelines

To ensure reliability of the device, follow the common printed-circuit board layout guidelines listed below:

- Use bypass capacitors on power supplies.
- Use short trace lengths to avoid excessive loading.

An example layout is given in Figure 13 for the DPW (X2SON-5) package. This example layout includes two 0402 (metric) capacitors, and uses the measurements that are in the package outline drawing appended to the end of this datasheet. A via of diameter 0.1 mm (3.973 mil) is placed directly in the center of the device. This via can be used to trace out the center pin connection through another board layer, or the via can be left out of the layout.

11.2 Layout Example

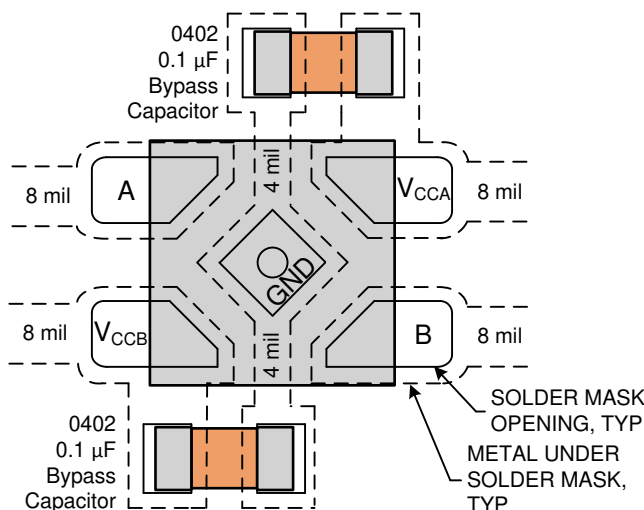

Figure 13. Example Layout for the DPW (X2SON-5) Package

12 Device and Documentation Support

12.1 Documentation Support

12.1.1 Related Documentation

For related documentation see the following:

- Texas Instruments, [Implications of Slow or Floating CMOS Inputs](#) application report
- Texas Instruments, [Designing and Manufacturing with TI's X2SON Packages](#) application report

12.2 Receiving Notification of Documentation Updates

To receive notification of documentation updates, navigate to the device product folder on ti.com. In the upper right corner, click on *Alert me* to register and receive a weekly digest of any product information that has changed. For change details, review the revision history included in any revised document.

12.3 Support Resources

TI E2E™ support forums are an engineer's go-to source for fast, verified answers and design help — straight from the experts. Search existing answers or ask your own question to get the quick design help you need.

Linked content is provided "AS IS" by the respective contributors. They do not constitute TI specifications and do not necessarily reflect TI's views; see TI's [Terms of Use](#).

12.4 Trademarks

E2E is a trademark of Texas Instruments.

12.5 Electrostatic Discharge Caution



This integrated circuit can be damaged by ESD. Texas Instruments recommends that all integrated circuits be handled with appropriate precautions. Failure to observe proper handling and installation procedures can cause damage.

ESD damage can range from subtle performance degradation to complete device failure. Precision integrated circuits may be more susceptible to damage because very small parametric changes could cause the device not to meet its published specifications.

12.6 Glossary

[SLYZ022](#) — *TI Glossary*.

This glossary lists and explains terms, acronyms, and definitions.

13 Mechanical, Packaging, and Orderable Information

The following pages include mechanical, packaging, and orderable information. This information is the most current data available for the designated devices. This data is subject to change without notice and revision of this document. For browser-based versions of this data sheet, refer to the left-hand navigation.

PACKAGING INFORMATION

Orderable Device	Status (1)	Package Type	Package Drawing	Pins	Package Qty	Eco Plan (2)	Lead finish/ Ball material (6)	MSL Peak Temp (3)	Op Temp (°C)	Device Marking (4/5)	Samples
2N7001TDCKR	ACTIVE	SC70	DCK	5	3000	RoHS & Green	SN	Level-1-260C-UNLIM	-40 to 125	DQ	Samples
2N7001TDPWR	ACTIVE	X2SON	DPW	5	3000	RoHS & Green	NIPDAUAG	Level-1-260C-UNLIM	-40 to 125	DP	Samples

(1) The marketing status values are defined as follows:

ACTIVE: Product device recommended for new designs.

LIFEBUY: TI has announced that the device will be discontinued, and a lifetime-buy period is in effect.

NRND: Not recommended for new designs. Device is in production to support existing customers, but TI does not recommend using this part in a new design.

PREVIEW: Device has been announced but is not in production. Samples may or may not be available.

OBSELETE: TI has discontinued the production of the device.

(2) **RoHS:** TI defines "RoHS" to mean semiconductor products that are compliant with the current EU RoHS requirements for all 10 RoHS substances, including the requirement that RoHS substance do not exceed 0.1% by weight in homogeneous materials. Where designed to be soldered at high temperatures, "RoHS" products are suitable for use in specified lead-free processes. TI may reference these types of products as "Pb-Free".

RoHS Exempt: TI defines "RoHS Exempt" to mean products that contain lead but are compliant with EU RoHS pursuant to a specific EU RoHS exemption.

Green: TI defines "Green" to mean the content of Chlorine (Cl) and Bromine (Br) based flame retardants meet JS709B low halogen requirements of <=1000ppm threshold. Antimony trioxide based flame retardants must also meet the <=1000ppm threshold requirement.

(3) MSL, Peak Temp. - The Moisture Sensitivity Level rating according to the JEDEC industry standard classifications, and peak solder temperature.

(4) There may be additional marking, which relates to the logo, the lot trace code information, or the environmental category on the device.

(5) Multiple Device Markings will be inside parentheses. Only one Device Marking contained in parentheses and separated by a "-" will appear on a device. If a line is indented then it is a continuation of the previous line and the two combined represent the entire Device Marking for that device.

(6) Lead finish/Ball material - Orderable Devices may have multiple material finish options. Finish options are separated by a vertical ruled line. Lead finish/Ball material values may wrap to two lines if the finish value exceeds the maximum column width.

Important Information and Disclaimer:The information provided on this page represents TI's knowledge and belief as of the date that it is provided. TI bases its knowledge and belief on information provided by third parties, and makes no representation or warranty as to the accuracy of such information. Efforts are underway to better integrate information from third parties. TI has taken and continues to take reasonable steps to provide representative and accurate information but may not have conducted destructive testing or chemical analysis on incoming materials and chemicals. TI and TI suppliers consider certain information to be proprietary, and thus CAS numbers and other limited information may not be available for release.

In no event shall TI's liability arising out of such information exceed the total purchase price of the TI part(s) at issue in this document sold by TI to Customer on an annual basis.

OTHER QUALIFIED VERSIONS OF 2N7001T :

- Automotive: [2N7001T-Q1](#)

NOTE: Qualified Version Definitions:

- Automotive - Q100 devices qualified for high-reliability automotive applications targeting zero defects

TAPE AND REEL INFORMATION



QUADRANT ASSIGNMENTS FOR PIN 1 ORIENTATION IN TAPE



*All dimensions are nominal

Device	Package Type	Package Drawing	Pins	SPQ	Reel Diameter (mm)	Reel Width W1 (mm)	A0 (mm)	B0 (mm)	K0 (mm)	P1 (mm)	W (mm)	Pin1 Quadrant
2N7001TDCKR	SC70	DCK	5	3000	178.0	9.0	2.4	2.5	1.2	4.0	8.0	Q3
2N7001TDPWR	X2SON	DPW	5	3000	178.0	8.4	0.91	0.91	0.5	2.0	8.0	Q3

TAPE AND REEL BOX DIMENSIONS

*All dimensions are nominal

Device	Package Type	Package Drawing	Pins	SPQ	Length (mm)	Width (mm)	Height (mm)
2N7001TDCKR	SC70	DCK	5	3000	180.0	180.0	18.0
2N7001TDPWR	X2SON	DPW	5	3000	205.0	200.0	33.0

GENERIC PACKAGE VIEW

DPW 5

X2SON - 0.4 mm max height

PLASTIC SMALL OUTLINE - NO LEAD



Images above are just a representation of the package family, actual package may vary.
Refer to the product data sheet for package details.

4211218-3/D

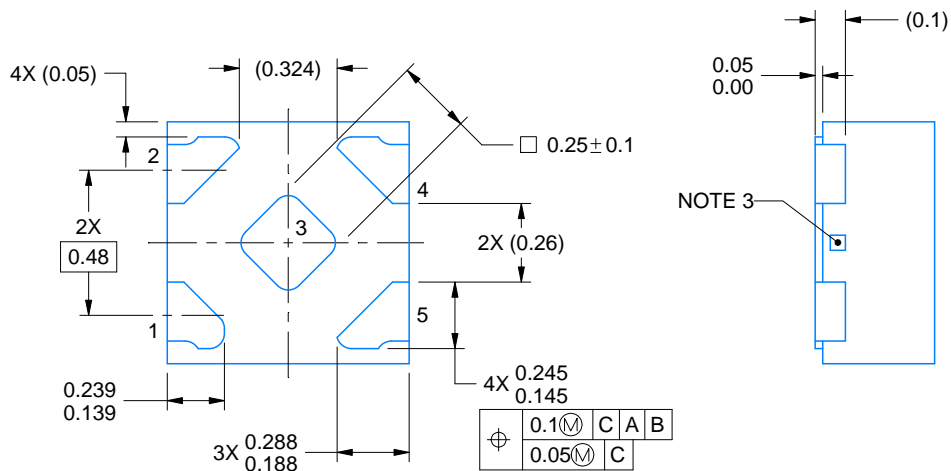

4223102/C 06/2021

NOTES:

1. All linear dimensions are in millimeters. Any dimensions in parenthesis are for reference only. Dimensioning and tolerancing per ASME Y14.5M.
2. This drawing is subject to change without notice.
3. The size and shape of this feature may vary.

EXAMPLE BOARD LAYOUT

DPW0005A

X2SON - 0.4 mm max height

PLASTIC SMALL OUTLINE - NO LEAD

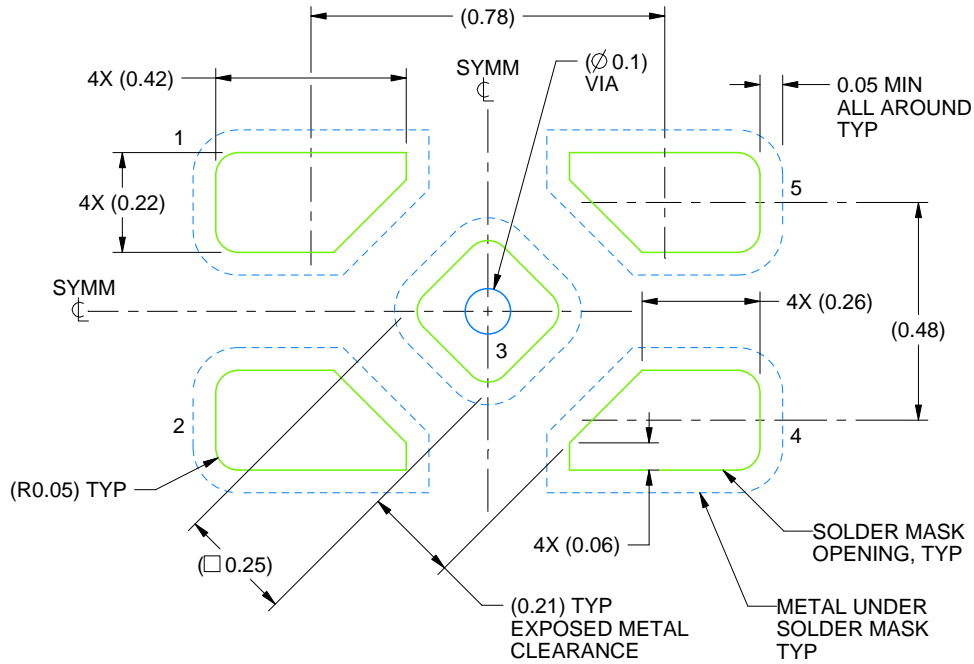

LAND PATTERN EXAMPLE
SOLDER MASK DEFINED
SCALE:60X

4223102/C 06/2021

NOTES: (continued)

4. This package is designed to be soldered to a thermal pad on the board. For more information, refer to QFN/SON PCB application note in literature No. SLUA271 (www.ti.com/lit/sl原因271).

EXAMPLE STENCIL DESIGN

DPW0005A

X2SON - 0.4 mm max height

PLASTIC SMALL OUTLINE - NO LEAD



SOLDER PASTE EXAMPLE
BASED ON 0.1 mm THICK STENCIL

EXPOSED PAD 3
92% PRINTED SOLDER COVERAGE BY AREA UNDER PACKAGE
SCALE:100X

4223102/C 06/2021

NOTES: (continued)

5. Laser cutting apertures with trapezoidal walls and rounded corners may offer better paste release. IPC-7525 may have alternate design recommendations.

DCK (R-PDSO-G5)

PLASTIC SMALL-OUTLINE PACKAGE

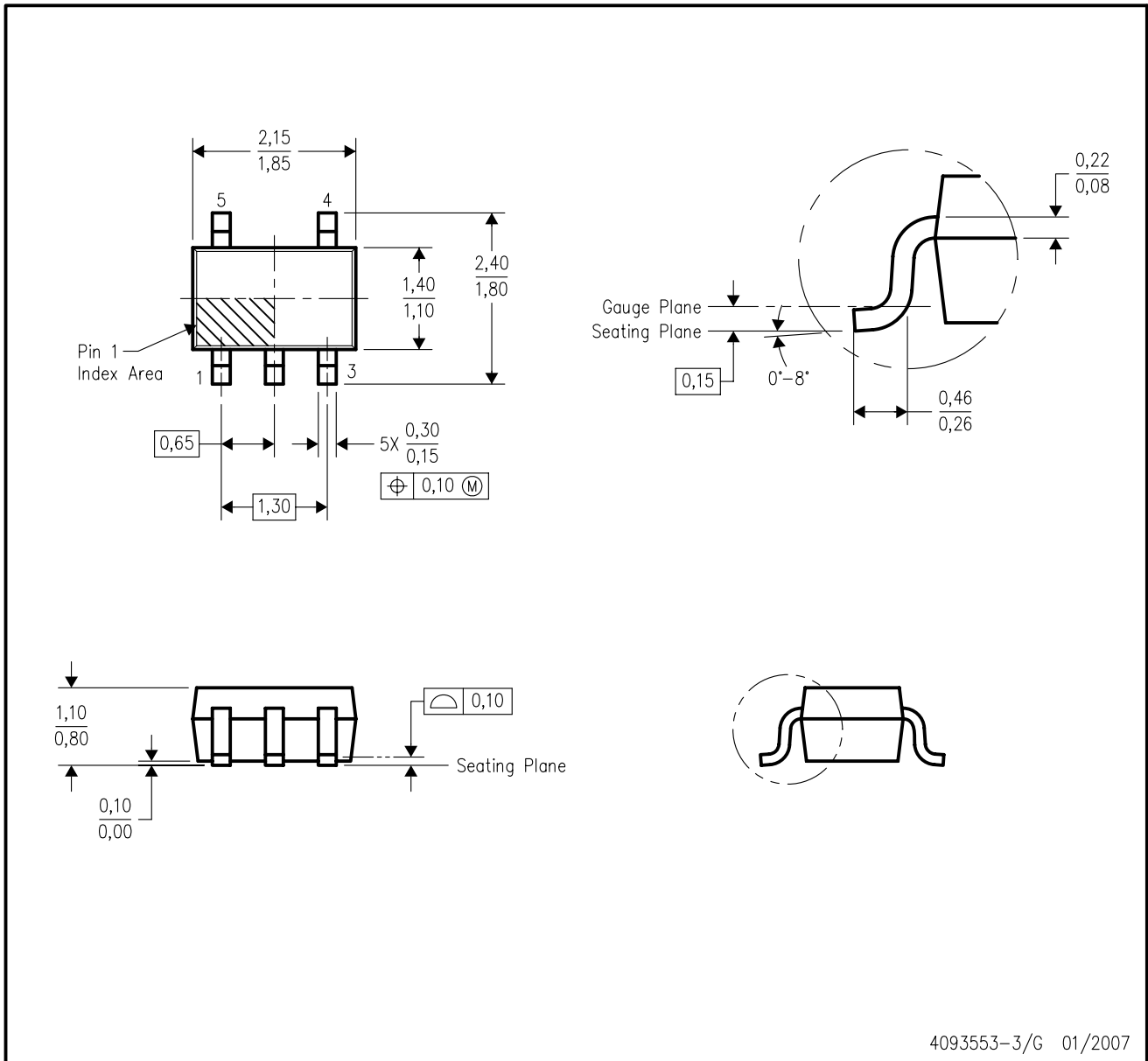

- NOTES:
- A. All linear dimensions are in millimeters.
 - B. This drawing is subject to change without notice.
 - C. Body dimensions do not include mold flash or protrusion. Mold flash and protrusion shall not exceed 0.15 per side.
 - D. Falls within JEDEC MO-203 variation AA.

DCK (R-PDSO-G5)

PLASTIC SMALL OUTLINE



- NOTES:
- A. All linear dimensions are in millimeters.
 - B. This drawing is subject to change without notice.
 - C. Customers should place a note on the circuit board fabrication drawing not to alter the center solder mask defined pad.
 - D. Publication IPC-7351 is recommended for alternate designs.
 - E. Laser cutting apertures with trapezoidal walls and also rounding corners will offer better paste release. Customers should contact their board assembly site for stencil design recommendations. Example stencil design based on a 50% volumetric metal load solder paste. Refer to IPC-7525 for other stencil recommendations.

IMPORTANT NOTICE AND DISCLAIMER

TI PROVIDES TECHNICAL AND RELIABILITY DATA (INCLUDING DATASHEETS), DESIGN RESOURCES (INCLUDING REFERENCE DESIGNS), APPLICATION OR OTHER DESIGN ADVICE, WEB TOOLS, SAFETY INFORMATION, AND OTHER RESOURCES "AS IS" AND WITH ALL FAULTS, AND DISCLAIMS ALL WARRANTIES, EXPRESS AND IMPLIED, INCLUDING WITHOUT LIMITATION ANY IMPLIED WARRANTIES OF MERCHANTABILITY, FITNESS FOR A PARTICULAR PURPOSE OR NON-INFRINGEMENT OF THIRD PARTY INTELLECTUAL PROPERTY RIGHTS.

These resources are intended for skilled developers designing with TI products. You are solely responsible for (1) selecting the appropriate TI products for your application, (2) designing, validating and testing your application, and (3) ensuring your application meets applicable standards, and any other safety, security, or other requirements. These resources are subject to change without notice. TI grants you permission to use these resources only for development of an application that uses the TI products described in the resource. Other reproduction and display of these resources is prohibited. No license is granted to any other TI intellectual property right or to any third party intellectual property right. TI disclaims responsibility for, and you will fully indemnify TI and its representatives against, any claims, damages, costs, losses, and liabilities arising out of your use of these resources.

TI's products are provided subject to TI's Terms of Sale (<https://www.ti.com/legal/termsofsale.html>) or other applicable terms available either on [ti.com](https://www.ti.com) or provided in conjunction with such TI products. TI's provision of these resources does not expand or otherwise alter TI's applicable warranties or warranty disclaimers for TI products.

Mailing Address: Texas Instruments, Post Office Box 655303, Dallas, Texas 75265
Copyright © 2021, Texas Instruments Incorporated

X-ON Electronics

Largest Supplier of Electrical and Electronic Components

Click to view similar products for [Translation - Voltage Levels](#) category:

Click to view products by [Texas Instruments](#) manufacturer:

Other Similar products are found below :

[NLSX4373DMR2G](#) [NLSX5012MUTAG](#) [NLSX0102FCT1G](#) [PCA9306FMUTAG](#) [MC100EPT622MNG](#) [NLSX3014MUTAG](#)
[NLSX5011MUTCG](#) [NLVSX4373MUTAG](#) [NB3U23CMNTAG](#) [NLSX3013BFCT1G](#) [NLV7WBD3125USG](#) [NLSX3012DMR2G](#)
[NLA9306MU3TCG](#) [PI4ULS3V304AZMAEX](#) [PI4ULS3V504AZMAEX](#) [74AVCH1T45FW3-7](#) [NLSX5011AMUTAG](#) [74AXP1T34GWH](#)
[ST2149BQTR](#) [MC100ELT21DR2G](#) [MC100LVELT22MNRG](#) [MC10ELT20DR2G](#) [MC10EPT20MNR4G](#) [MC14504BFELG](#)
[NLSV4T3234FCT1G](#) [NLSX3378BFCT1G](#) [UM3208QA](#) [UM3208H](#) [UM3304](#) [UM3304QT](#) [UM3202H](#) [RS0104YTQE12](#) [RS0204YUTQH12](#)
[RS0104YTQF14](#) [RS0204YTQF14](#) [UM3204QT](#) [UM3204QB](#) [UM3204QV](#) [UM3304QS](#) [SN74LXC2T45DCUR](#) [TCA39306DTMR](#)
[NTS0102TL-Q100H](#) [AW39112DNR](#) [RS4T774XTSS16](#) [RS4T774XTQQ16](#) [RS0302YH8](#) [RS0208YTQC20](#) [RS8T245YS24](#)
[RS2T245XUTQK10](#) [RS4T774XTQW16](#)