

具有高电流输出、用于旋转变压器励磁的 ALM2402F-Q1 汽车类双路运算放大器

1 特性

- 符合面向汽车应用的 AEC-Q100 标准：
 - 温度等级 1：-40°C 至 +125°C， T_A
- 提供功能安全
 - 可帮助进行功能安全系统设计的文档
- 低失调电压：1mV (典型值)
- 高输出电流驱动：400mA 持续电流 (每通道)
 - 取代分立式运算放大器和晶体管
- 两个电源的宽电源电压范围 (最高 16V)
- 过热关断
- 电流限制
- 实现低 I_Q 应用的关断引脚
- 在大容性负载下保持稳定
- 2MHz 增益带宽，具有 3.4V/ μ s 的压摆率
- 内部射频/EMI 滤波器
- 封装：14 引脚 HTSSOP (PWP)

2 应用

- 基于旋转变压器的汽车应用
- 逆变器和电机控制
- 制动系统
- 电动助力转向 (EPS)
- 后视镜模块
- 汽车电子视镜
- 伺服驱动器功率级模块

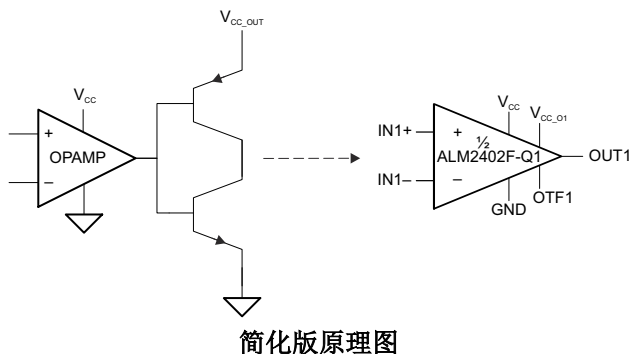

3 说明

ALM2402F-Q1 是一款双电源运算放大器，其特性和性能使该器件更适合基于旋转变压器的汽车应用。该器件具有高增益带宽和压摆率以及连续高输出电流驱动功能，从而成为提供现代旋转变压器所需的低失真和差分高振幅激励的理想之选。在易受故障影响的电路上驱动模拟信号时，电流限制和过热检测功能可增强整体系统稳健性。

ALM2402F-Q1 的轨到轨输出通过低 $R_{ds(on)}$ PMOS 和 NMOS 晶体管实现，可保持较低的功率耗散。具有散热焊盘和低 $R_{\theta JA}$ 的小型 HTSSOP 封装使用户能够向负载提供高电流，同时最大程度地减小布板空间。当用于现代混合动力和电动汽车时，该最小化的布板空间是 ALM2402F-Q1 提供的主要优势之一。

通过本页底部的最大输出电压与频率间的关系图，可确定 ALM2402F-Q1 的最大输出电压。

器件信息(1)

器件型号	封装	封装尺寸 (标称值)
ALM2402F-Q1	HTSSOP (14)	5.00mm × 4.40mm

(1) 要了解所有可用封装，请参见数据表末尾的封装选项附录。

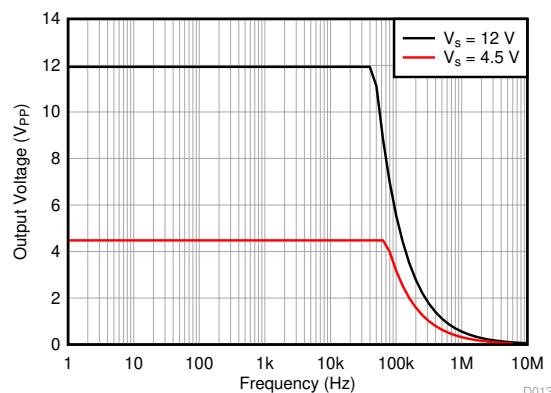

最大输出电压与频率间的关系

D013



Table of Contents

1 特性	1	7.4 Device Functional Modes.....	17
2 应用	1	8 Application and Implementation	18
3 说明	1	8.1 Application Information.....	18
4 Revision History	2	8.2 Typical Application.....	19
5 Pin Configuration and Functions	3	9 Power Supply Recommendations	23
6 Specifications	4	10 Layout	24
6.1 Absolute Maximum Ratings.....	4	10.1 Layout Guidelines.....	24
6.2 ESD Ratings.....	4	10.2 Layout Example.....	24
6.3 Recommended Operating Conditions.....	4	11 Device and Documentation Support	25
6.4 Thermal Information.....	5	11.1 Documentation Support.....	25
6.5 Electrical Characteristics: $V_S = 12\text{ V}$	5	11.2 接收文档更新通知.....	25
6.6 Electrical Characteristics: $V_S = 5\text{ V}$	6	11.3 支持资源.....	25
6.7 Typical Characteristics.....	8	11.4 Trademarks.....	25
7 Detailed Description	14	11.5 Electrostatic Discharge Caution.....	25
7.1 Overview.....	14	11.6 术语表.....	25
7.2 Functional Block Diagram.....	14	12 Mechanical, Packaging, and Orderable Information	25
7.3 Feature Description.....	15		

4 Revision History

注：以前版本的页码可能与当前版本的页码不同

Changes from Revision A (September 2019) to Revision B (October 2021)	Page
• 更新了整个文档中的表格、图和交叉参考的编号格式.....	1
• 向 <i>特性</i> 部分添加了功能安全的项目符号.....	1

Changes from Revision * (May 2019) to Revision A (September 2019)	Page
• 将器件状态从预告信息 (预发布) 更改为量产数据 (正在供货)	1

5 Pin Configuration and Functions



图 5-1. PWP (14-Pin HTSSOP) Package, Top View

表 5-1. Pin Functions

PIN		I/O	DESCRIPTION
NAME	NO.		
GND	6, 14	Input	Ground pin (both ground pins must be used and connected together on board)
IN(1)+	2	Input	Noninverting op amp input terminal 1
IN(2)+	4	Input	Noninverting op amp input terminal 2
IN(1) -	1	Input	Inverting op amp input terminal 1
IN(2) -	5	Input	Inverting op amp input terminal 2
NC	7, 8	—	No internal connection (do no connect)
OTF/SH_DN	3	Input/output	Overtemperature flag and shutdown (see 表 7-1 for truth table)
OUT(1)	13	Output	Op amp output 1
OUT(2)	9	Output	Op amp output 2
VS	11	Input	Gain stage supply pin
VS_O(1)	12	Input	Output stage supply pin
VS_O(2)	10	Input	Output stage supply pin
Thermal pad	—	—	Connect the exposed thermal pad to ground for best thermal performance. Do not connect the thermal pad to any pin other than GND. The thermal pad can also be left floating.

6 Specifications

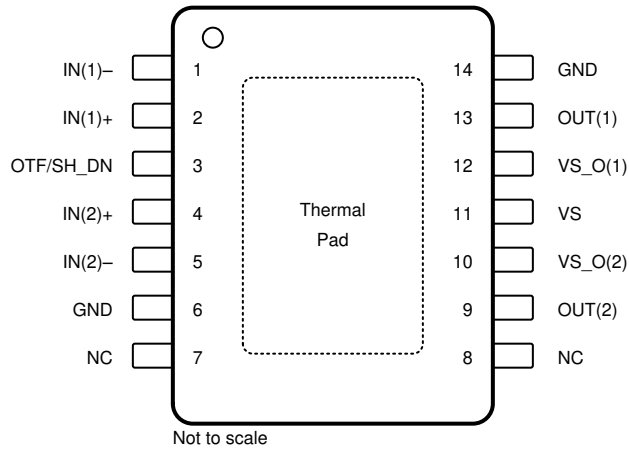
6.1 Absolute Maximum Ratings

over operating free-air temperature range (unless otherwise noted) ⁽¹⁾

	MIN	MAX	UNIT
Input supply voltage, $V_S = (V+) - (V-)$	- 0.3	18	V
Output supply voltage, V_{S_O}	- 0.3	18	V
Positive and negative input to GND voltage	- 0.3	18	V
Overtemperature flag pin current		20	mA
Overtemperature flag pin voltage	0	7	V
Output short-circuit ⁽²⁾	Continuous	Continuous	
Operating temperature	- 40	125	°C
Junction temperature		150	°C
Storage temperature, T_{stg}	- 65	150	°C

- (1) Stresses beyond those listed under *Absolute Maximum Ratings* may cause permanent damage to the device. These are stress ratings only, which do not imply functional operation of the device at these or any other conditions beyond those indicated under *Recommended Operating Conditions*. Exposure to absolute-maximum-rated conditions for extended periods may affect device reliability.
- (2) Short-circuit to ground; one amplifier per package. Long-term, short-circuit operation leads to an elevated die temperature and a shorter lifetime, and places the amplifier into open-loop operation. Prolonged open-loop operation (especially at high temperatures and supplies) can lead to a shift in the dc electrical characteristics, such as offset voltage (see the [Open-Loop and Closed-Loop Operation](#) section).

6.2 ESD Ratings

			VALUE	UNIT
$V_{(ESD)}$	Electrostatic discharge	Human-body model (HBM), per AEC Q100-002 ⁽¹⁾ HBM ESD Classification Level 2	±2000	V
		Charge Device Model (CDM), per AEC Q100-011 CDM ESD Classification Level C5	±750	

- (1) AEC Q100-002 indicates that HBM stressing shall be in accordance with the ANSI/ESDA/JEDEC JS-001 specification

6.3 Recommended Operating Conditions

over operating free-air temperature range (unless otherwise noted)

	MIN	NOM	MAX	UNIT
Input supply voltage, $V_S = (V+) - (V-)$	4.5		16	V
Output supply voltage, V_{S_O}	3		16	V
Continuous output current (sourcing) ⁽¹⁾			400	mA
Continuous output current (sinking) ⁽¹⁾			400	mA
OTF input high voltage (op amp on or full operational state)	1			V
OTF input low voltage (op amp off or shutdown state)			0.35	V
Positive and negative input to GND voltage	0		7	V
Overtemperature flag pin voltage	2		5	V
Specified temperature	- 40		125	°C

- (1) Current Limit must be taken into consideration when choosing maximum output current.

6.4 Thermal Information

THERMAL METRIC ⁽¹⁾		ALM2402FQ1	UNIT
		PWP (TSSOP)	
		14 PINS	
$R_{\theta JA}$	Junction-to-ambient thermal resistance	46.5	°C/W
$R_{\theta JC(top)}$	Junction-to-case (top) thermal resistance	33.0	°C/W
$R_{\theta JB}$	Junction-to-board thermal resistance	27.6	°C/W
ψ_{JT}	Junction-to-top characterization parameter	1.5	°C/W
ψ_{JB}	Junction-to-board characterization parameter	27.4	°C/W
$R_{\theta JC(bot)}$	Junction-to-case (bottom) thermal resistance	2.2	°C/W

(1) For more information about traditional and new thermal metrics, see the [Semiconductor and IC Package Thermal Metrics application report](#).

6.5 Electrical Characteristics: $V_S = 12\text{ V}$

at $T_A = 25^\circ\text{C}$, $V_S = V_{S_{O1}} = V_{S_{O2}} = 12\text{ V}$, $R_L = 10\text{ k}\Omega$ connected to $V_S / 2$, $V_{CM} = V_S / 2$, $V_{OTF} = 5\text{ V}$, and $V_O = V_S / 2$ (unless otherwise noted)

PARAMETER		TEST CONDITIONS	MIN	TYP	MAX	UNIT
OFFSET VOLTAGE						
V_{OS}	Input offset voltage			± 1	± 7	mV
		$T_A = -40^\circ\text{C}$ to $+125^\circ\text{C}$			± 15	
dV_{OS}/dT	Input offset voltage drift	$T_A = -40^\circ\text{C}$ to $+125^\circ\text{C}$		65		$\mu\text{V}/^\circ\text{C}$
PSRR	Input offset voltage versus power supply	$V_S = 10\text{ V}$ to 16 V	70	76		dB
		$V_S = 10\text{ V}$ to 16 V , $T_A = -40^\circ\text{C}$ to $+125^\circ\text{C}$	65			
INPUT BIAS CURRENT						
I_B	Input bias current			± 3.5	± 15	nA
		$T_A = -40^\circ\text{C}$ to $+125^\circ\text{C}$			± 140	
I_{OS}	Input offset current			± 2	± 12	nA
		$T_A = -40^\circ\text{C}$ to $+125^\circ\text{C}$			± 35	
NOISE						
	Input voltage noise	$f = 0.1\text{ Hz}$ to 10 Hz		35		μV_{PP}
				5.5		μV_{RMS}
e_N	Input voltage noise density	$f = 1\text{ kHz}$		115		$\text{nV}/\sqrt{\text{Hz}}$
i_N	Input current noise	$f = 1\text{ kHz}$		20		$\text{fA}/\sqrt{\text{Hz}}$
INPUT VOLTAGE RANGE						
V_{CM}	Common-mode voltage	$V_S > 8.2\text{ V}$	0.2		7	V
CMRR	Common-mode rejection ratio	$0.2\text{ V} < V_{CM} < 7\text{ V}$	81	97		dB
		$T_A = -40^\circ\text{C}$ to $+125^\circ\text{C}$, $0.2\text{ V} < V_{CM} < 7\text{ V}$	52			
OPEN-LOOP GAIN						
A_{OL}	Open-loop voltage gain	$0.3\text{ V} < V_O < (V_S) - 1.5\text{ V}$, $R_L = 10\text{ k}\Omega$		85	93	dB
			$T_A = -40^\circ\text{C}$ to $+125^\circ\text{C}$	60		
FREQUENCY RESPONSE						
GBW	Gain-bandwidth product	$C_L = 15\text{ pF}$		2.1		MHz
SR	Slew rate	5-V step, $G = +1\text{ V/V}$, $C_L = 50\text{ pF}$		3.4		$\text{V}/\mu\text{s}$
t_s	Settling time	To 0.1%, 5-V step, $G = +1\text{ V/V}$		2.4		μs
	Overload recovery time	$V_{IN} \times (-1) \times \text{gain} > V_S$		10		μs
THD+N	Total harmonic distortion + noise	$(V^+) = 11\text{ V}$, $(V^-) = -5\text{ V}$, $V_O = 6\text{ V}_{PP}$, $G = +2\text{ V/V}$, $f = 1\text{ kHz}$, $R_L = 100\ \Omega$		-73		dB

6.5 Electrical Characteristics: $V_S = 12\text{ V}$ (continued)

at $T_A = 25^\circ\text{C}$, $V_S = V_{S_O1} = V_{S_O2} = 12\text{ V}$, $R_L = 10\text{ k}\Omega$ connected to $V_S / 2$, $V_{CM} = V_S / 2$, $V_{OTF} = 5\text{ V}$, and $V_O = V_S / 2$ (unless otherwise noted)

PARAMETER	TEST CONDITIONS		MIN	TYP	MAX	UNIT
OUTPUT						
V_O	Voltage output swing from rail	Positive rail, $V_{ID} = 100\text{ mV}$	$T_A = 25^\circ\text{C}$	0.3	0.5	mV
			$T_A = -40^\circ\text{C}$ to $+125^\circ\text{C}$, $I_{SOURCE} = 200\text{ mA}$	130	300	
			$T_A = -40^\circ\text{C}$ to $+125^\circ\text{C}$, $I_{SOURCE} = 100\text{ mA}$	60	150	
		Negative rail, $V_{ID} = 100\text{ mV}$	$T_A = 25^\circ\text{C}$	0.4	0.6	mV
			$T_A = -40^\circ\text{C}$ to $+125^\circ\text{C}$, $I_{SINK} = 200\text{ mA}$	200	550	
			$T_A = -40^\circ\text{C}$ to $+125^\circ\text{C}$, $I_{SINK} = 100\text{ mA}$	100	200	
I_{SC}	Short-circuit current	Sinking (short to supply)		540		mA
		Sourcing (short to ground)		750		
POWER SUPPLY						
I_Q	Quiescent current per amplifier	$I_O = 0\text{ A}$, $T_A = 25^\circ\text{C}$		4	5	mA
		$I_O = 0\text{ A}$, $T_A = -40^\circ\text{C}$ to $+125^\circ\text{C}$			6	
		$V_{OTF}/SH_DN = 0\text{ V}$		0.5		
TEMPERATURE						
	Thermal shutdown			165		$^\circ\text{C}$
	Thermal shutdown recovery			159		$^\circ\text{C}$
V_{OL_OTF}	Overtemperature fault low voltage	$R_{PULLUP} = 2.5\text{ k}\Omega$, $V_{PULLUP} = 5.0\text{ V}$			400	mV
V_{IH_OTF}	Amplifier enable voltage		1			V
V_{IL_OTF}	Amplifier disable voltage				0.35	V

6.6 Electrical Characteristics: $V_S = 5\text{ V}$

at $T_A = 25^\circ\text{C}$, $V_S = V_{S_O1} = V_{S_O2} = 5\text{ V}$, $R_L = 10\text{ k}\Omega$ connected to $V_S / 2$, $V_{CM} = V_S / 2$, $V_{OTF} = 5\text{ V}$, and $V_O = V_S / 2$ (unless otherwise noted)

PARAMETER	TEST CONDITIONS		MIN	TYP	MAX	UNIT
OFFSET VOLTAGE						
V_{OS}	Input offset voltage	$T_A = 25^\circ\text{C}$		± 1	± 7	mV
		$T_A = -40^\circ\text{C}$ to $+125^\circ\text{C}$			± 15	
dV_{OS}/dT	Input offset voltage drift	$T_A = -40^\circ\text{C}$ to $+125^\circ\text{C}$		65		$\mu\text{V}/^\circ\text{C}$
PSRR	Input offset voltage versus power supply	$V_S = 4.5\text{ V}$ to 10 V	82	94		dB
		$V_S = 4.5\text{ V}$ to 10 V , $T_A = -40^\circ\text{C}$ to $+125^\circ\text{C}$	75			
INPUT BIAS CURRENT						
I_B	Input bias current	$T_A = 25^\circ\text{C}$		0.5	± 2	nA
		$T_A = -40^\circ\text{C}$ to $+125^\circ\text{C}$			± 30	
I_{OS}	Input offset current	$T_A = 25^\circ\text{C}$		± 2	± 2	nA
		$T_A = -40^\circ\text{C}$ to $+125^\circ\text{C}$			± 9	
NOISE						
	Input voltage noise	$f = 0.1\text{ Hz}$ to 10 Hz		35		μV_{PP}
				5.5		μV_{RMS}
e_N	Input voltage noise density	$f = 1\text{ kHz}$		115		$\text{nV}/\sqrt{\text{Hz}}$
i_N	Input current noise	$f = 1\text{ kHz}$		20		$\text{fA}/\sqrt{\text{Hz}}$

6.6 Electrical Characteristics: $V_S = 5\text{ V}$ (continued)

at $T_A = 25^\circ\text{C}$, $V_S = V_{S_O1} = V_{S_O2} = 5\text{ V}$, $R_L = 10\text{ k}\Omega$ connected to $V_S / 2$, $V_{CM} = V_S / 2$, $V_{OTF} = 5\text{ V}$, and $V_O = V_S / 2$ (unless otherwise noted)

PARAMETER		TEST CONDITIONS	MIN	TYP	MAX	UNIT
INPUT VOLTAGE RANGE						
V_{CM}	Common-mode voltage		0.2	(V+) - 1.2		V
CMRR	Common-mode rejection ratio	$0.2\text{ V} < V_{CM} < (V+) - 1.2\text{ V}$	80	95		dB
		$T_A = -40^\circ\text{C}$ to $+125^\circ\text{C}$, $0.2\text{ V} < V_{CM} < (V+) - 1.2\text{ V}$	52			
OPEN-LOOP GAIN						
A_{OL}	Open-loop voltage gain	$0.3\text{ V} < V_O < (V_S) - 1.5\text{ V}$, $R_L = 10\text{ k}\Omega$	$T_A = 25^\circ\text{C}$	85	93	dB
			$T_A = -40^\circ\text{C}$ to $+125^\circ\text{C}$	60		
FREQUENCY RESPONSE						
GBW	Gain-bandwidth product	$C_L = 15\text{ pF}$		1.3		MHz
SR	Slew rate	2-V step, $G = +1\text{ V/V}$, $C_L = 50\text{ pF}$		1.7		V/ μs
t_S	Settling time	To 0.1%, 2-V step, $G = +1\text{ V/V}$		2		μs
	Overload recovery time	$V_{IN} \times (-1) \times \text{gain} > V_S$		5		μs
THD+N	Total harmonic distortion + noise	$V_S = 5\text{ V}$, $V_O = 2.82\text{ V}_{PP}$, $G = +2\text{ V/V}$, $f = 1\text{ kHz}$, $R_L = 100\ \Omega$		-73		dB
OUTPUT						
V_O	Voltage output swing from rail	Positive rail, $V_{ID} = 100\text{ mV}$	$T_A = 25^\circ\text{C}$	0.3	0.5	mV
			$T_A = -40^\circ\text{C}$ to $+125^\circ\text{C}$, $I_{SINK} = 200\text{ mA}$	130	300	
			$T_A = -40^\circ\text{C}$ to $+125^\circ\text{C}$, $I_{SINK} = 100\text{ mA}$	60	150	
		Negative rail, $V_{ID} = 100\text{ mV}$	$T_A = 25^\circ\text{C}$	0.4	0.6	mV
			$T_A = -40^\circ\text{C}$ to $+125^\circ\text{C}$, $I_{SINK} = 200\text{ mA}$	200	575	
			$T_A = -40^\circ\text{C}$ to $+125^\circ\text{C}$, $I_{SINK} = 100\text{ mA}$	100	200	
I_{SC}	Short-circuit current	Sinking (short to supply)		500		mA
		Sourcing (short to ground)		550		
POWER SUPPLY						
I_Q	Quiescent current per amplifier	$I_O = 0\text{ A}$, $T_A = 25^\circ\text{C}$		4	4.5	mA
		$I_O = 0\text{ A}$, $T_A = -40^\circ\text{C}$ to $+125^\circ\text{C}$			5	
		$V_{OTF/SH_DN} = 0\text{ V}$		0.5		
TEMPERATURE						
	Thermal shutdown			165		$^\circ\text{C}$
	Thermal shutdown recovery			159		$^\circ\text{C}$
V_{OL_OTF}	Overtemperature fault low voltage	$R_{PULLUP} = 2.5\text{ k}\Omega$, $V_{PULLUP} = 5.0\text{ V}$			400	mV
V_{IH_OTF}	Amplifier enable voltage		1			V
V_{IL_OTF}	Amplifier disable voltage				0.35	V

6.7 Typical Characteristics

at $T_A = 25^\circ\text{C}$, $V_S = 12\text{ V}$, $V_{CM} = V_{S_{O1}} = V_{S_{O2}} = V_S/2$, and $R_L = 10\text{ k}\Omega$ (unless otherwise noted)

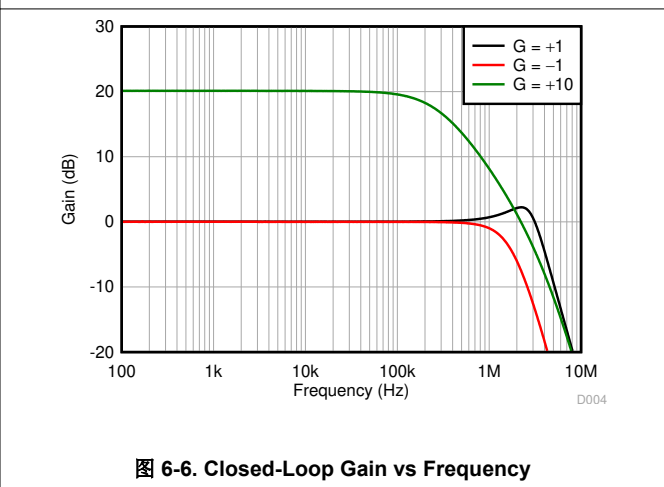
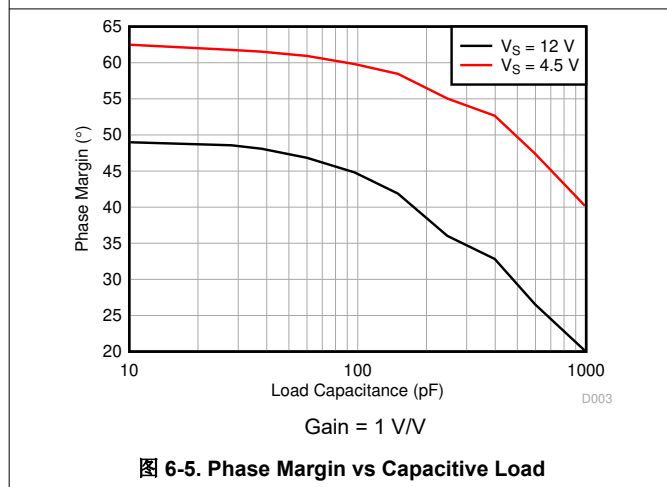
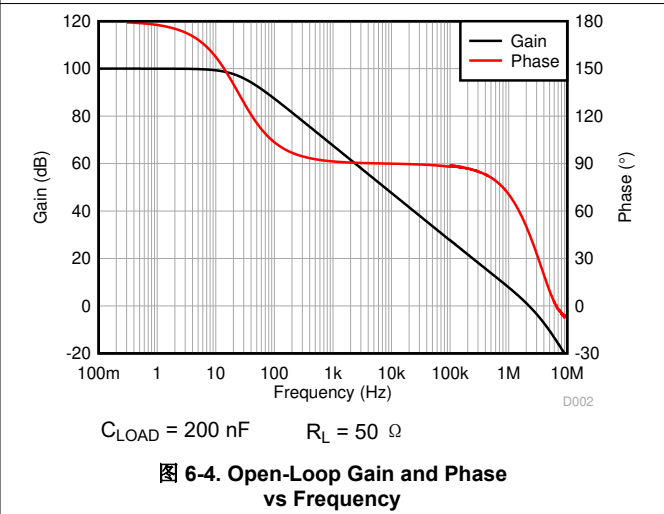
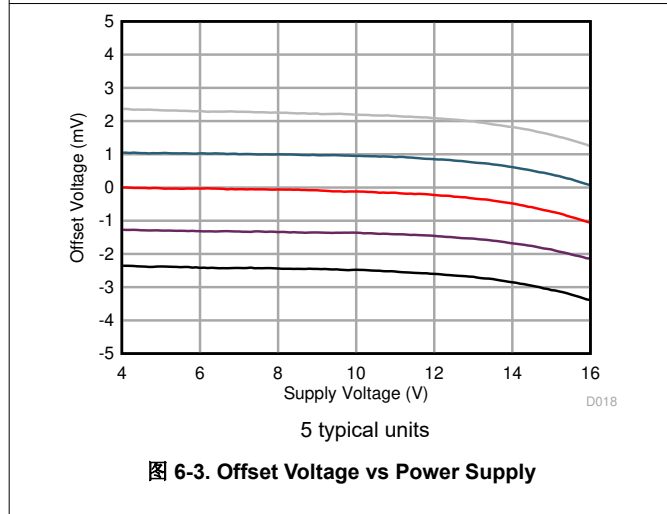
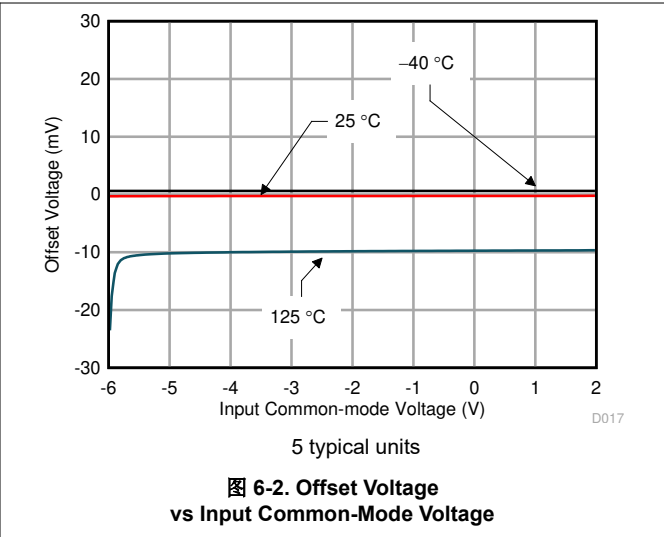
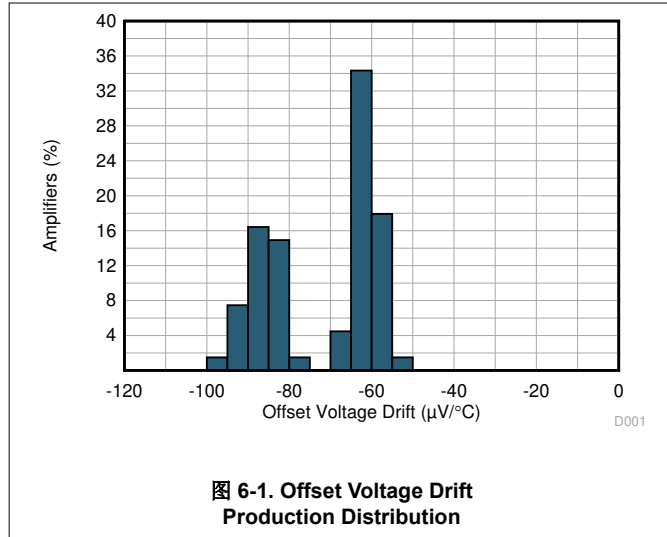

6.7 Typical Characteristics (continued)

at $T_A = 25^\circ\text{C}$, $V_S = 12\text{ V}$, $V_{CM} = V_{S_O1} = V_{S_O2} = V_S/2$, and $R_L = 10\text{ k}\Omega$ (unless otherwise noted)

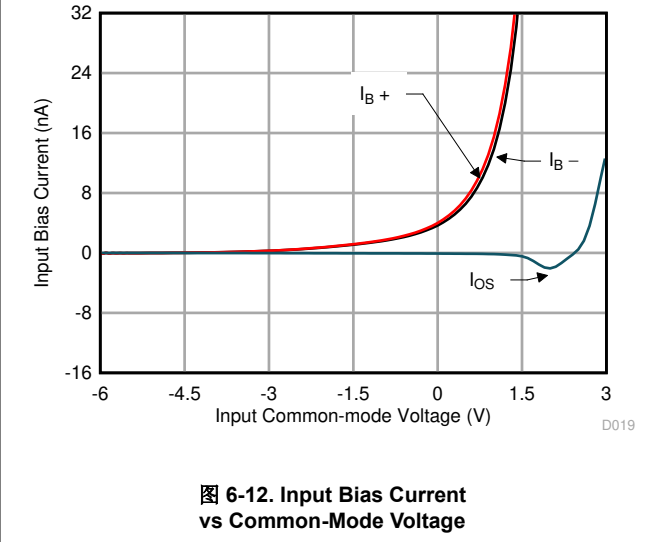
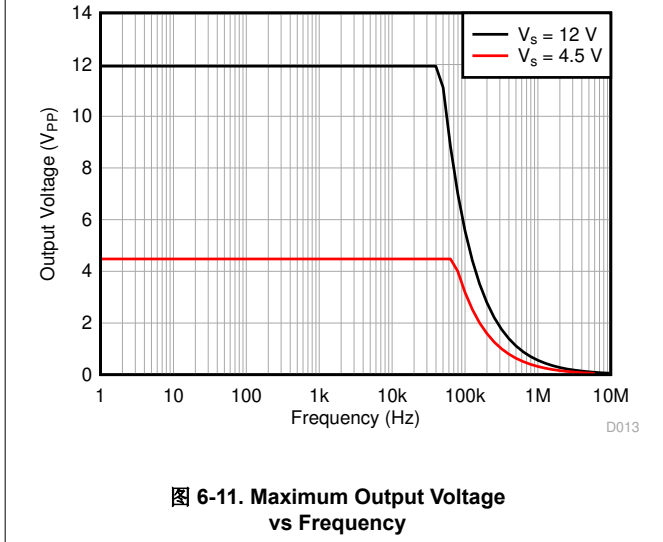
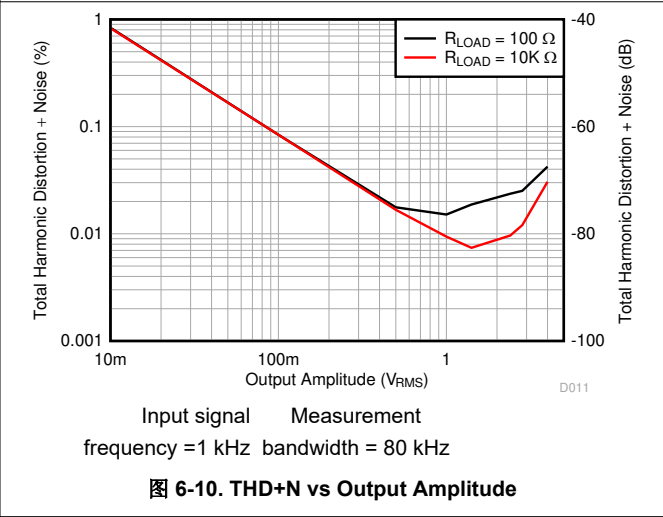
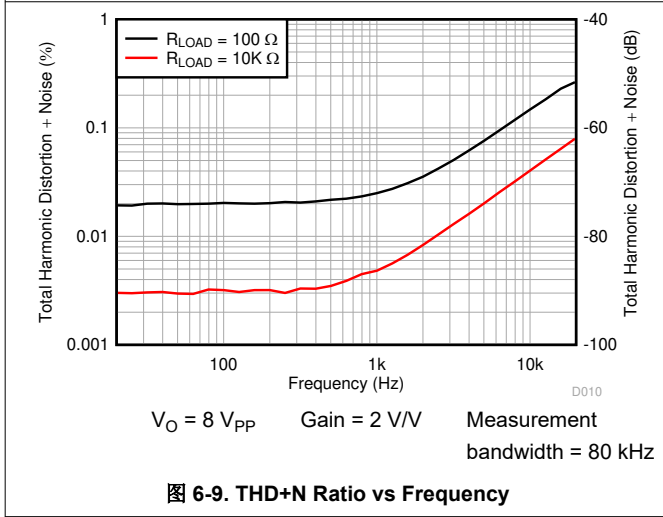
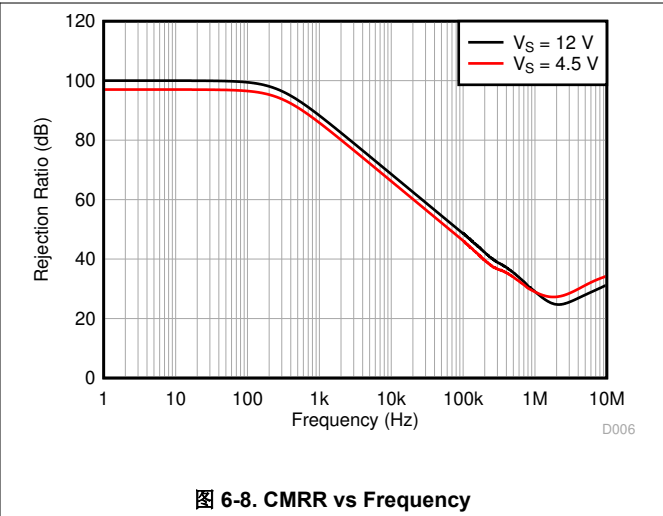
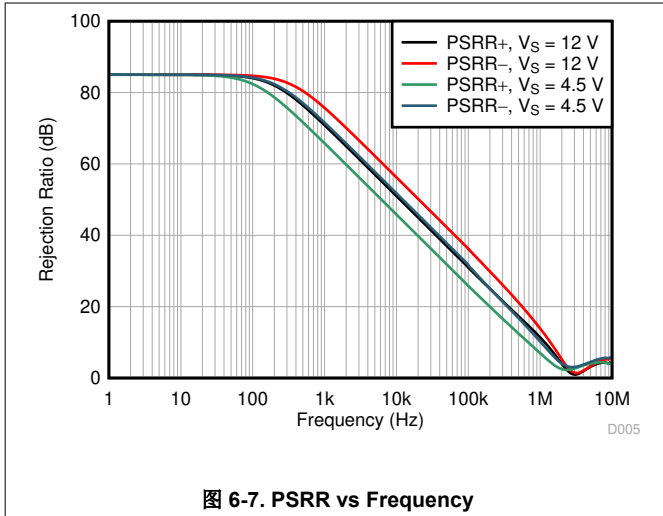

6.7 Typical Characteristics (continued)

at $T_A = 25^\circ\text{C}$, $V_S = 12\text{ V}$, $V_{CM} = V_{S_O1} = V_{S_O2} = V_S/2$, and $R_L = 10\text{ k}\Omega$ (unless otherwise noted)



图 6-13. Input Bias Current vs Temperature



图 6-14. Output Voltage Swing vs Output Source Current

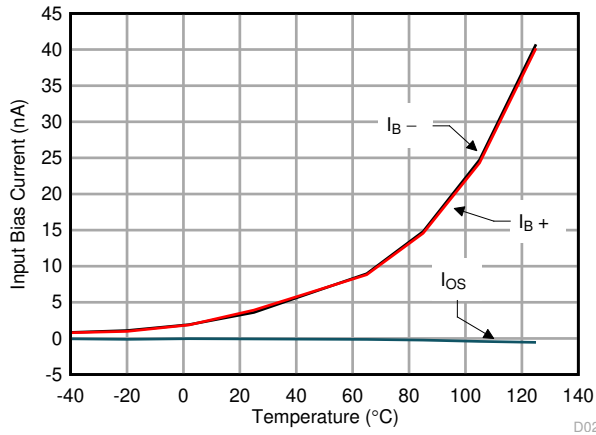

图 6-15. Output Voltage Swing vs Output Sink Current

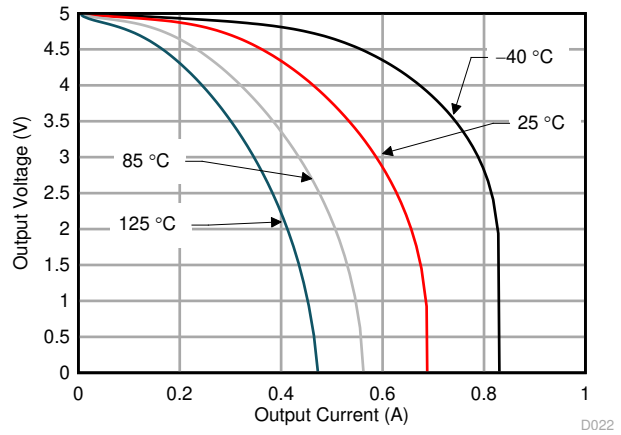

图 6-16. CMRR vs Temperature

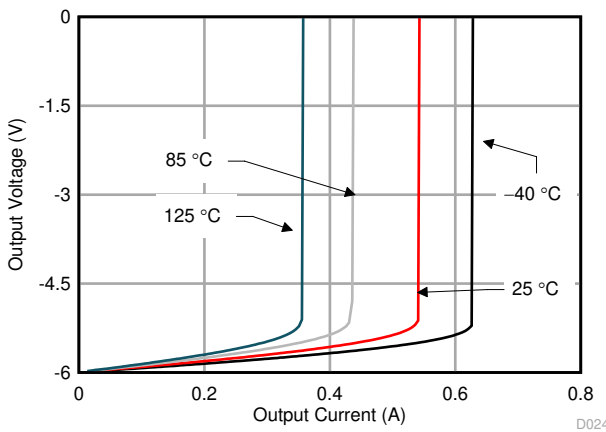

图 6-17. PSRR vs Temperature

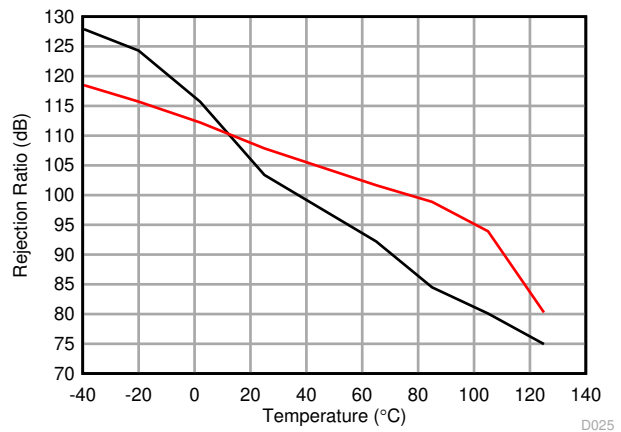

图 6-18. 0.1-Hz to 10-Hz Noise

6.7 Typical Characteristics (continued)

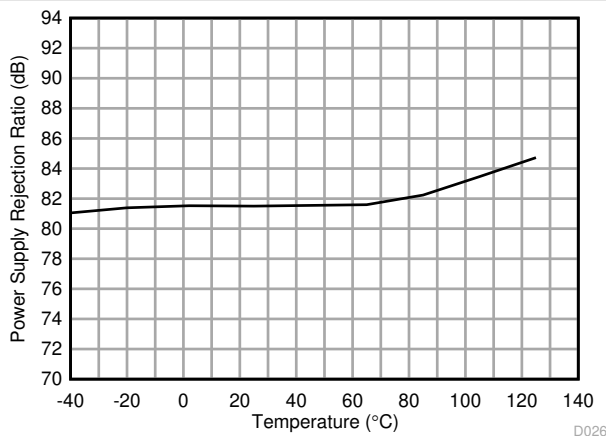
at $T_A = 25^\circ\text{C}$, $V_S = 12\text{ V}$, $V_{CM} = V_{S_O1} = V_{S_O2} = V_S/2$, and $R_L = 10\text{ k}\Omega$ (unless otherwise noted)

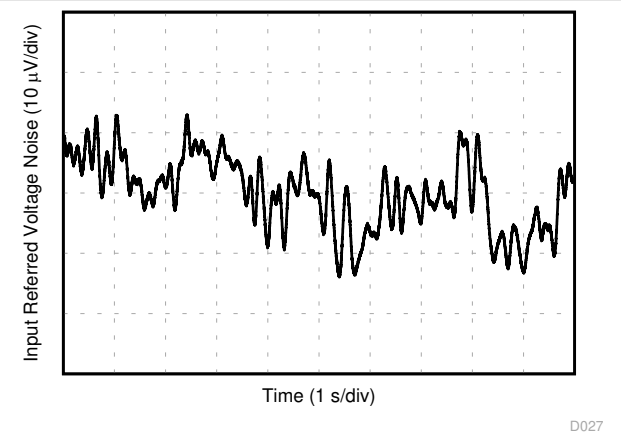

图 6-19. Input Voltage Spectral Noise Density vs Frequency



5 typical units $V_O = 8\text{ V}_{PP}$

图 6-20. Quiescent Current vs Power Supply

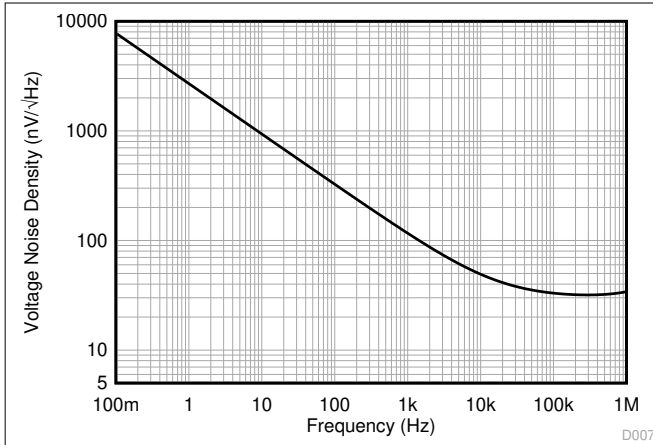
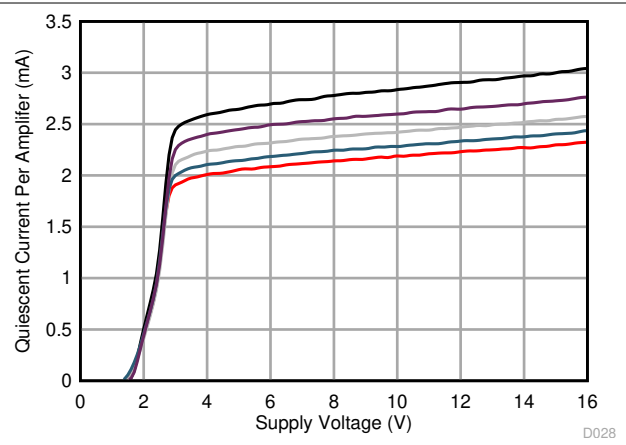

图 6-21. Quiescent Current vs Temperature



图 6-22. Open-Loop Gain vs Temperature

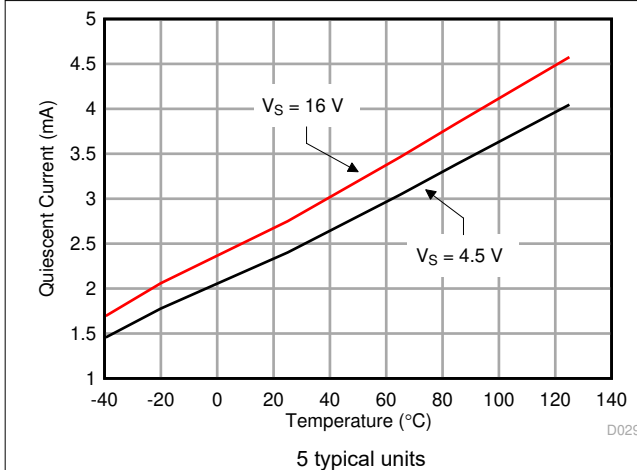

图 6-23. Open-Loop Output Impedance vs Frequency

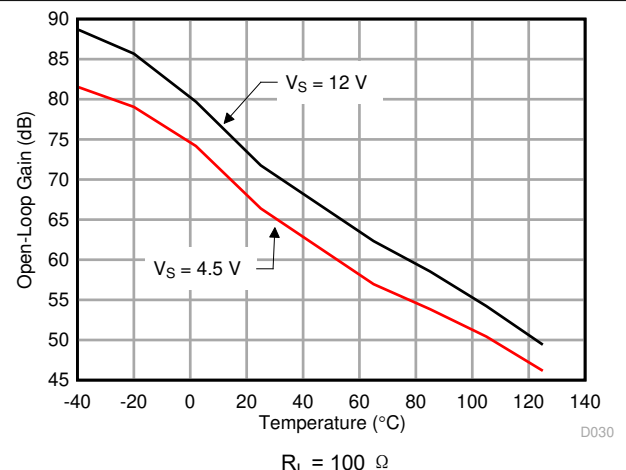

10-mV output step Gain = -1 V/V

图 6-24. Small-Signal Overshoot vs Capacitive Load

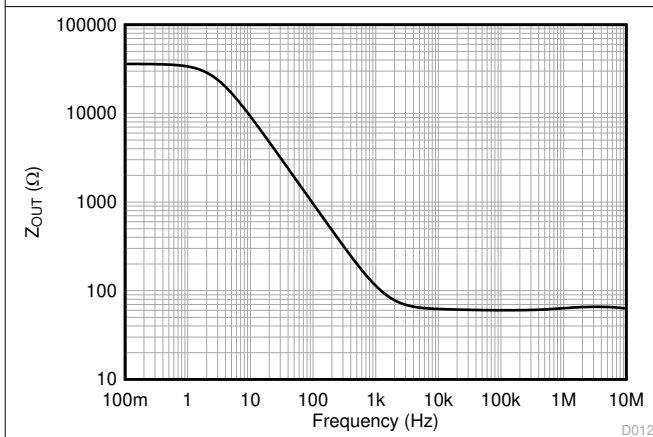
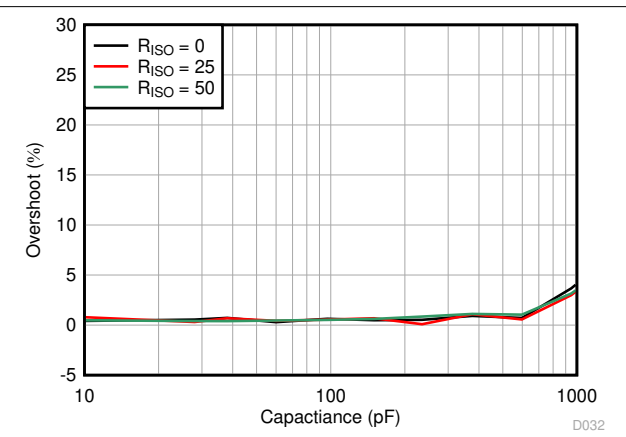
ALM2402F-Q1

ZHCSJP5B - MAY 2019 - REVISED OCTOBER 2021

6.7 Typical Characteristics (continued)

at $T_A = 25^\circ\text{C}$, $V_S = 12\text{ V}$, $V_{CM} = V_{S_{O1}} = V_{S_{O2}} = V_S/2$, and $R_L = 10\text{ k}\Omega$ (unless otherwise noted)

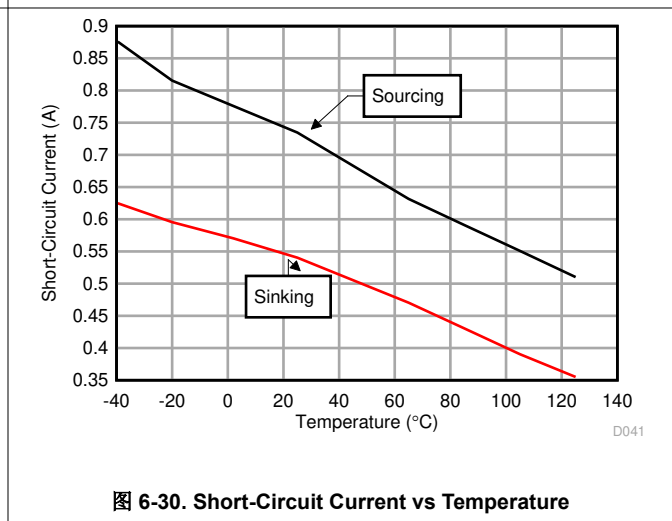
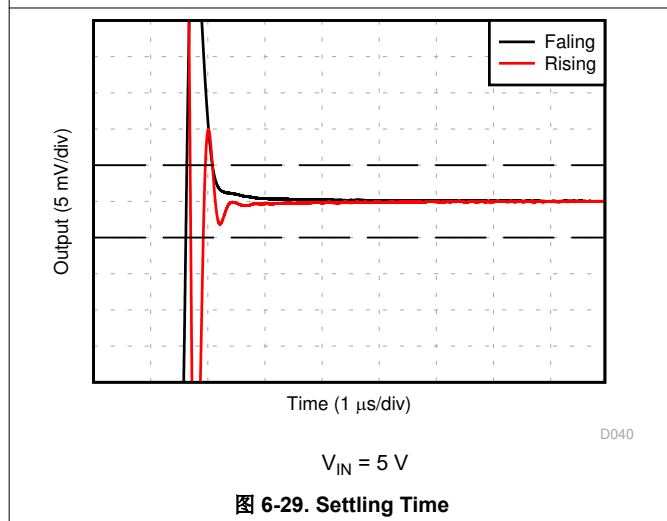
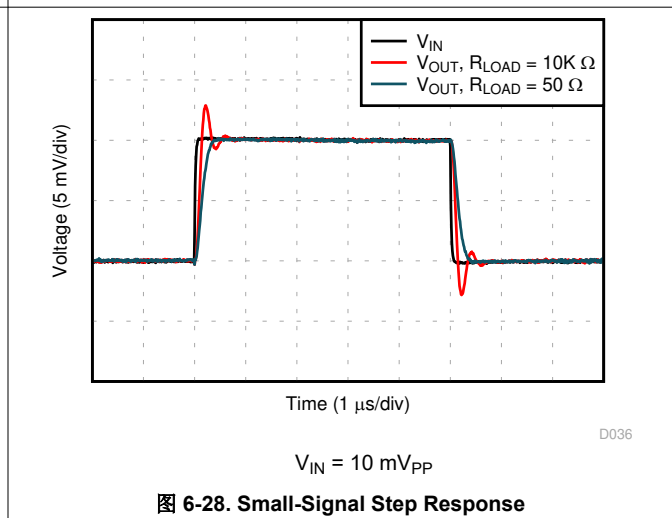
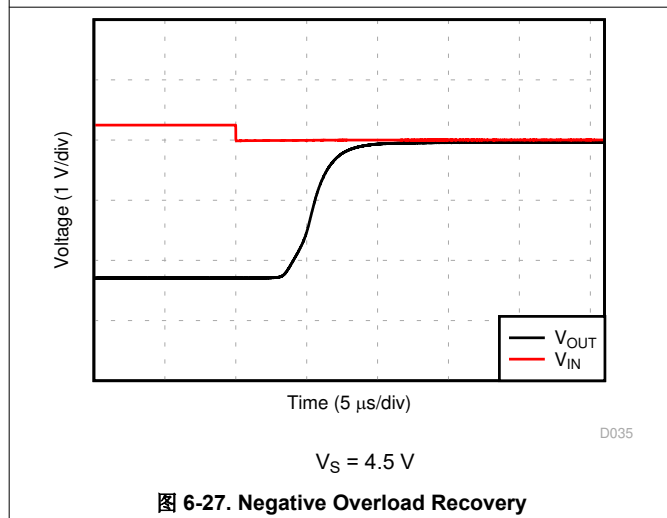
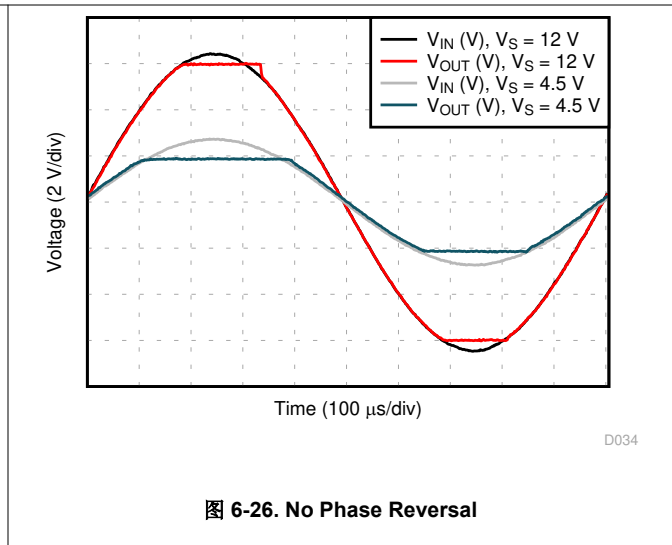
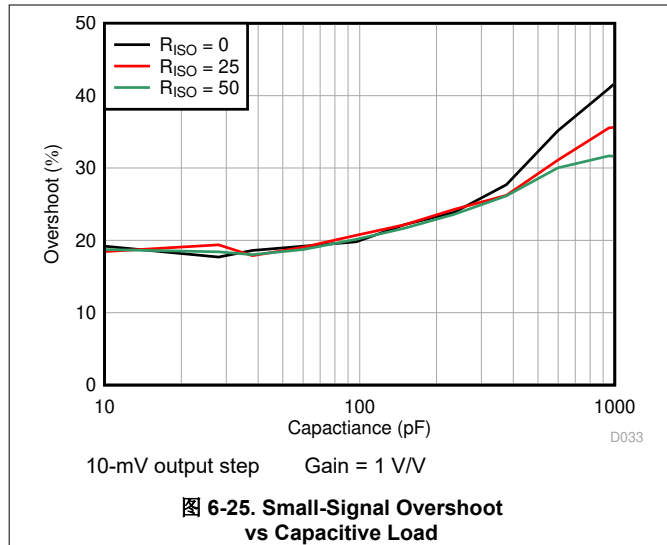

6.7 Typical Characteristics (continued)

at $T_A = 25^\circ\text{C}$, $V_S = 12\text{ V}$, $V_{CM} = V_{S_O1} = V_{S_O2} = V_S/2$, and $R_L = 10\text{ k}\Omega$ (unless otherwise noted)



图 6-31. EMIRR vs Frequency

7 Detailed Description

7.1 Overview

The ALM2402F-Q1 is a dual-power op amp qualified for use in automotive applications. Key features for this device are low offset voltage, high output current drive capability, and high FPBW capability. The device also offers protection features such as thermal shutdown and current limit. The 14-pin HTSSOP package minimizes board space and power dissipation.

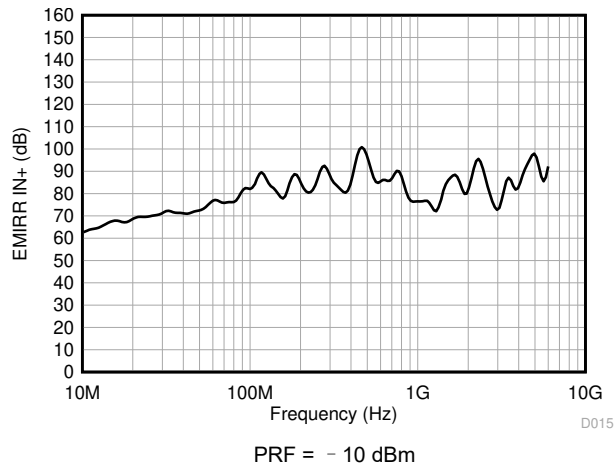
7.2 Functional Block Diagram

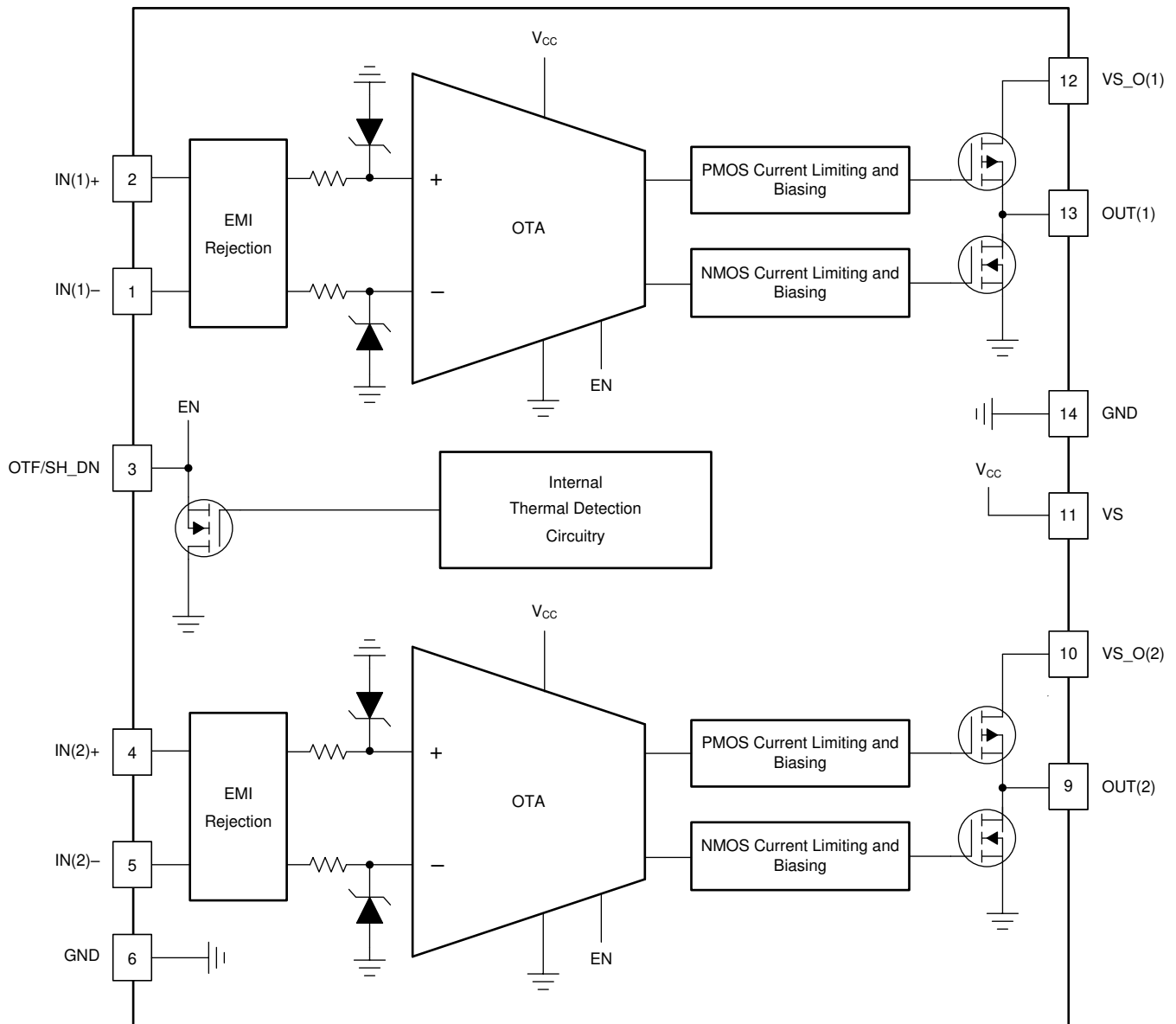

7.3 Feature Description

7.3.1 OTF/SH_DN

The overtemperature and shutdown (OTF/SH_DN) pin is a bidirectional pin that allows both op amps to be put into a low I_Q state ($\sim 500 \mu\text{A}$) when forced low or less than V_{IL_OTF} . As a result of this pin being bidirectional, and the respective enable and disable functionality, this pin must be pulled high or greater than V_{IH_OTF} through a pullup resistor; see the [Electrical Characteristics](#) table.

When the junction temperature of ALM2402F-Q1 exceeds the limits specified in the [Recommended Operating Conditions](#) table, the OTF/SH_DN pin goes low to alert the application that both the outputs have turned off because of an overtemperature event. Also, the OTF pin goes low if VS_O1 and VS_O2 are 0 V. In case of an overtemperature event, the op amps are shut down even if OTF/SH_DN is forced high.

When OTF/SH_DN is pulled low and the op amps are shut down, the op amps are in an open loop, even when there is negative feedback applied. This occurrence is due to the loss of the open-loop gain in the op amps when the biasing is disabled. See [# 7.4.1](#) for more details on open- and closed-loop considerations.

7.3.2 Output Stage Supply Voltage

The ALM2402F-Q1 uses three power rails. VS powers the op-amp signal path (OTA) and protection circuitry. VS_O1 and VS_O2 power the output high side driver. Each supply can operate at separate voltage levels (higher or lower). The minimum and maximum values listed in the [Recommended Operating Conditions](#) table are voltages that enable the ALM2402F-Q1 to properly function at or near the specification listed in [Electrical Characteristics](#) table.

7.3.3 Current-Limit and Short-Circuit Protection

Each op amp in the ALM2402F-Q1 has separate internal current limiting for the PMOS (high-side) and NMOS (low-side) output transistors. If the output is shorted to ground then the PMOS (high-side) current limit is activated, and limits the current to 750 mA nominally. If the output is shorted to supply then the NMOS (low-side) current limit is activated and limits the current to 550 mA nominally at 25°C. The current limit value decreases with increasing temperature as a result of the temperature coefficient of a base-emitter junction voltage. Similarly, the current limit value increases at low temperatures.

In the case of short-to-ground scenarios, a programmable current limit for the PMOS (high-side) is achieved by adding resistance between $VS_O(x)$, where $x = 1$ or 2 , and the supply VS . The added current limit resistor reduces the drain-source voltage across the PMOS output transistor, thus reducing the output current drive capability. For a desired current limit (I_{LIMIT}), an appropriate current limiting resistor (R_{LIMIT}) is selected using [Equation 1](#).

$$R_{LIMIT} = (VS - 1.5) / I_{LIMIT} \quad (1)$$

When current is limited, the safe limits for the die temperature must be taken in to account; see the [Recommended Operating Conditions](#) and [Absolute Maximum Ratings](#) tables. With too much power dissipation, the die temperature can surpass thermal shutdown limits; the op amp shuts down and reactivates after the die has fallen below thermal limits. However, do not continuously operate the device in thermal hysteresis for long periods of time (see the [Absolute Maximum Ratings](#) table).

7.3.4 Input Common-Mode Overvoltage Clamps

The input common mode range of the ALM2402F-Q1 is between $(V^-) + 0.2\text{ V}$ and $(V^+) - 1.2\text{ V}$ (see the [Electrical Characteristics](#) table). Staying within this range allows the op amps to perform and operate within the specification listed in the [Electrical Characteristics](#). Operating beyond these limits can cause distortion and nonlinearities.

In order for the inputs to tolerate high voltages in the event of a short to supply, Zener diodes have been added (see [Figure 7-1](#)). The current into this Zener diode is limited through internal resistors ($10\text{ k}\Omega$ each). When operating near or above the Zener voltage (7 V), the additional voltage error caused by the mismatch in internal resistors must be taken in to account. In unity gain configurations, the op amp forces both gate voltages to be equal to the Zener voltage on the positive input pin, and ideally both Zeners sink the same amount of current and force the output voltage to be equal to V_{IN} . However, in reality, R_N and R_P and V_Z between both Zener diodes do not perfectly match, and have some percentage difference between their values. This occurrence leads to the output being $V_O = V_{IN} \times (\Delta R + \Delta V_Z)$.



图 7-1. Schematic Including Input Clamps

7.3.5 Thermal Shutdown

If the die temperature exceeds safe limits, all outputs are disabled, and the OTF/SH_DN pin is driven low. After the die temperature has fallen to a safe level, operation automatically resumes. The OTF/SH_DN pin is released after operation has resumed.

When operating the die at a high temperature, the op amp toggles on and off between the thermal shutdown hysteresis. In this event, the safe limits for the die temperature must be taken in to account; see the [Recommended Operating Conditions](#) and [Thermal Conditions](#) tables. Do not continuously operate the device in thermal hysteresis for long periods of time; see the [Recommended Operating Conditions](#) table.

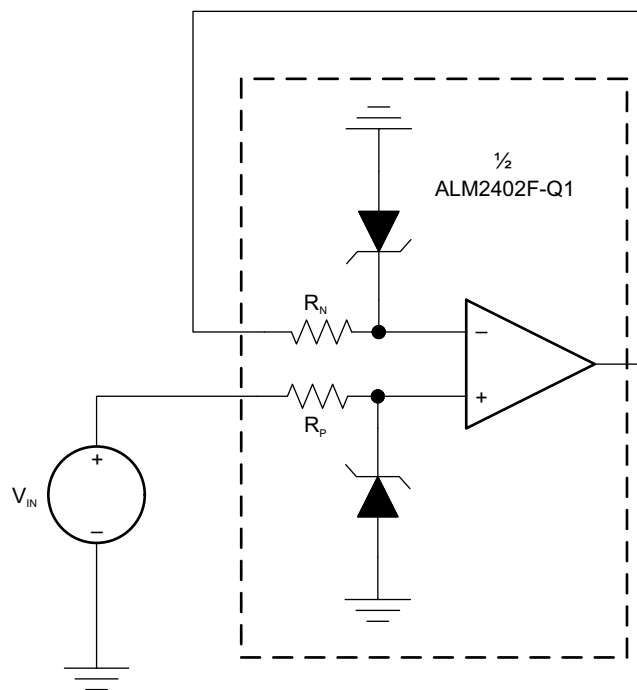
7.3.6 Output Stage

Designed as a high-voltage, high current operational amplifier, the ALM2402F-Q1 device delivers a robust output drive capability. A class AB output stage with common-source transistors is used to achieve full rail-to-rail output swing capability. For resistive loads up to 10 k Ω , the output swings typically to within 5 mV of either supply rail regardless of the power-supply voltage applied. Different load conditions change the ability of the amplifier to swing close to the rails.

Each output transistor has internal reverse diodes between drain and source that conduct if the output is forced greater than the supply or less than ground (reverse current flow). These diodes can be used as flyback protection in inductive-load driving applications. Limit the use of these diodes to pulsed operation to minimize junction temperature overheating due to ($V_F \times I_F$). Internal current limiting circuitry does not operate when current is flown in the reverse direction and the reverse diodes are active.

7.3.7 EMI Susceptibility and Input Filtering

Op amps vary with regard to the susceptibility of the device to electromagnetic interference (EMI). If conducted EMI enters the op amp, the dc offset observed at the amplifier output may shift from the nominal value while EMI is present. This shift is a result of signal rectification associated with the internal semiconductor junctions. While all op-amp pin functions can be affected by EMI, the signal input pins are likely to be the most susceptible. The ALM2402F-Q1 incorporates an internal input low-pass filter that reduces the amplifiers response to EMI. Both common-mode and differential mode filtering are provided by this filter.

Texas Instruments has developed the ability to accurately measure and quantify the immunity of an operational amplifier over a broad frequency spectrum extending from 10 MHz to 990 MHz. The EMI rejection ratio (EMIRR) metric allows op amps to be directly compared by the EMI immunity. Detailed information can also be found in the [EMI Rejection Ratio of Operational Amplifiers application report](#), available for download from www.ti.com.

7.4 Device Functional Modes

7.4.1 Open-Loop and Closed-Loop Operation

As a result of the very high open-loop dc gain of the ALM2402F-Q1, the device functions as a comparator in open-loop for most applications. As noted in the [Electrical Characteristics](#) table, the majority of electrical characteristics are verified in negative feedback, closed-loop configurations. Certain dc electrical characteristics, like offset, may have a higher drift across temperature and lifetime when continuously operated in open loop over the lifetime of the device.

7.4.2 Shutdown

When the OTF/SH_DN pin is left floating or is grounded, the op amp shuts down to a low I_Q state and does not operate; the op amp outputs go to a high-impedance state. See the [OTF/SH_DN](#) section for more detailed information on the OTF/SH_DN pin.

表 7-1. Shutdown Truth Table

NAME	LOGIC STATE	OP AMP STATE
OTF/SH_DN	High (> V_{IH_OTF} see Recommended Operating Conditions)	Operating
	Low (< V_{IL_OTF} see Recommended Operating Conditions)	Shutdown (low I_Q state)

8 Application and Implementation

Note

以下应用部分中的信息不属于 TI 器件规格的范围，TI 不担保其准确性和完整性。TI 的客户应负责确定器件是否适用于其应用。客户应验证并测试其设计，以确保系统功能。

8.1 Application Information

The ALM2402F-Q1 is a dual-power op amp with performance and protection features that are optimal for many applications. For op amps, there are many general design consideration that must taken into account. The following sections describe what to consider for most closed-loop applications, and gives a specific example of the ALM2402F-Q1 being used in a motor-drive application.

8.1.1 Capacitive Load and Stability

The ALM2402F-Q1 is designed to be used in applications where driving a capacitive load is required. As with all op amps, specific instances can occur where the ALM2402F-Q1 device can become unstable. The particular op-amp circuit configuration, layout, gain, and output loading are some of the factors to consider when establishing whether or not an amplifier is stable in operation. An op amp in the unity-gain (1 V/V) buffer configuration that drives a capacitive load exhibits a greater tendency to be unstable than an amplifier operated at a higher-noise gain. The capacitive load, in conjunction with the op-amp output resistance, creates a pole within the feedback loop that degrades the phase margin. The degradation of the phase margin increases as the capacitive loading increases. When operating in the unity-gain configuration, the ALM2402F-Q1 remains stable with a pure capacitive load up to approximately 1 nF. Increasing the amplifier closed-loop gain allows the amplifier to drive increasingly larger capacitance. This increased capability is evident when observing the overshoot response of the amplifier at higher voltage gains.

One technique for increasing the capacitive load drive capability of the amplifier operating in a unity-gain configuration is to insert a small resistor, typically 100 m Ω to 10 Ω , in series with the output (R_S), as shown in [图 8-1](#). This resistor significantly reduces the overshoot and ringing associated with large capacitive loads.



图 8-1. Capacitive Load Drive

8.2.1 Design Requirements

For this design example, use the parameters listed in [表 8-1](#) as the input parameters.

表 8-1. Design Parameters

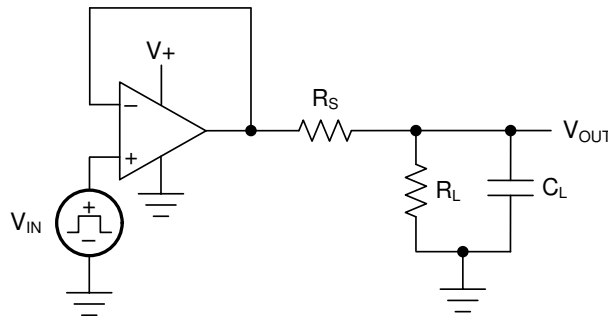
DESIGN PARAMETER	EXAMPLE VALUE
Ambient temperature range	- 40°C to +125°C
Available supply voltages	12 V
EMC capacitance (CL)	50 nF
Excitation input voltage range	2 V _{RMS} to 7 V _{RMS}
Excitation frequency	10 kHz

8.2.2 Detailed Design Procedure

When using the ALM2402F-Q1 in a resolver application, determine:

- Resolver excitation input impedance or resistance and inductance: $Z_0 = 100 + j188$; ($R = 100 \Omega$ and $L = 3$ mH)
- Resolver transformation ratio (V_{EXC} / V_{SINCOS}): 0.5 V/V at 10 kHz
- Package and $R_{\theta JA}$: HTSSOP, 46.5°C/W
- Op amp maximum junction temperature: 150°C
- Op amp bandwidth: 1.3 MHz
- Op amp Slew Rate: 1.2 V/ μ s

8.2.2.1 Resolver Excitation Input (Op Amp Output)

Like a transformer, a resolver needs an alternating current input to function properly. The resolver receives alternating current from the primary coil (excitation input) and creates a multiple of this input current on the secondary sides (SIN, COS ports). When determining how to generate this alternating current, make sure to understand the op amp abilities and limitations. For the excitation input, the resolver input impedance, stability RMS voltage, and desired frequency must be taken in to account.

8.2.2.1.1 Excitation Voltage

The resolver primary winding or excitation coil can be driven by a single-ended op amp output with the other side of the coil grounded, or differentially as shown in [图 8-2](#). A differential drive offers higher voltage (double) on to the excitation coil, while not using as much output voltage headroom from the op amp. This larger output voltage due to the differential drive leads to lower distortion on the output signal.

For this example, the resolver impedance is specified from 2 V_{RMS} and 7 V_{RMS} up to 20-kHz maximum frequency. To highlight use with a 7 V_{RMS} resolver, an excitation voltage of 10 V_{PP} is applied from each channel of the ALM2402F-Q1. The op amp is set in an inverting gain = - 2 V/V, while applying an adequate common-mode bias. These conditions give the required 7 V_{RMS} differential output (3.5 V_{RMS} per each op amp channel) to the resolver primary winding without running into any op-amp headroom issues.

Another consideration for excitation is op-amp power dissipation. As described in the [Power Dissipation and Thermal Reliability](#) section, power dissipation from the op amp can be lowered by driving the output peak voltages close to the supply and ground voltages. With the very low V_{OH}/V_{OL} of the ALM2402F-Q1, lower power dissipation is easily accomplished. See the [Output Stage](#) section for a further description of the rail-rail output stage.

8.2.2.1.2 Excitation Frequency

The excitation frequency is chosen based on the desired secondary-side output signal resolution. The excitation signal is similar to a sampling pulse in ADCs, with the real information being in the envelope created by the rotor. With a GBW of 1.3 MHz, the ALM2402F-Q1 has more than enough open-loop gain at 10 kHz to create negligible closed-loop gain error.

Along with GBW, the ALM2402F-Q1 has optimal THD and SR performance to achieve 10-V_{PP} output per channel.

8.2.2.1.3 Excitation Impedance

Knowledge of the primary-side impedance is very important when choosing an op amp for this application. As shown in 图 8-3, the excitation coil looks like an inductance in series with a resistance. Often, these values are not given, or are given as a function of frequency or phase angle, and must be calculated from the Cartesian or polar form. This calculation is a trivial task.

After the coil resistance is determined, the maximum or peak-peak current needed from ALM2402F-Q1 is determined using Equation 2:

$$I_{OUT} = \frac{V_{PP}}{R_L} \quad (2)$$

In this example, the peak-to-peak output current equates to approximately 100 mA. Each op amp handles the peak current, with one op amp sinking current while the other op amp is sourcing current. Knowledge of the op amp current is very important when determining the device power dissipation, a topic that is discussed in [Power Dissipation and Thermal Reliability](#).



图 8-3. Excitation Coil Implementation

As shown in 图 8-3, designers often add a resistor (R_{CRS}) in series with a capacitor (C_{CRS}) to eliminate crossover distortion. This distortion occurs as a result of the biasing of BJTs in a discrete implementation. With the ALM2402F-Q1 rail-rail output and high-output current drive capability, this configuration is rarely needed.

Common practice is to also add EMC capacitors to the op-amp outputs to help shield other devices on the PCB from the radiation created by the motor and resolver. When choosing C_{EMC} , make sure to take the stability of the op amp into account.

8.2.2.2 Resolver Output

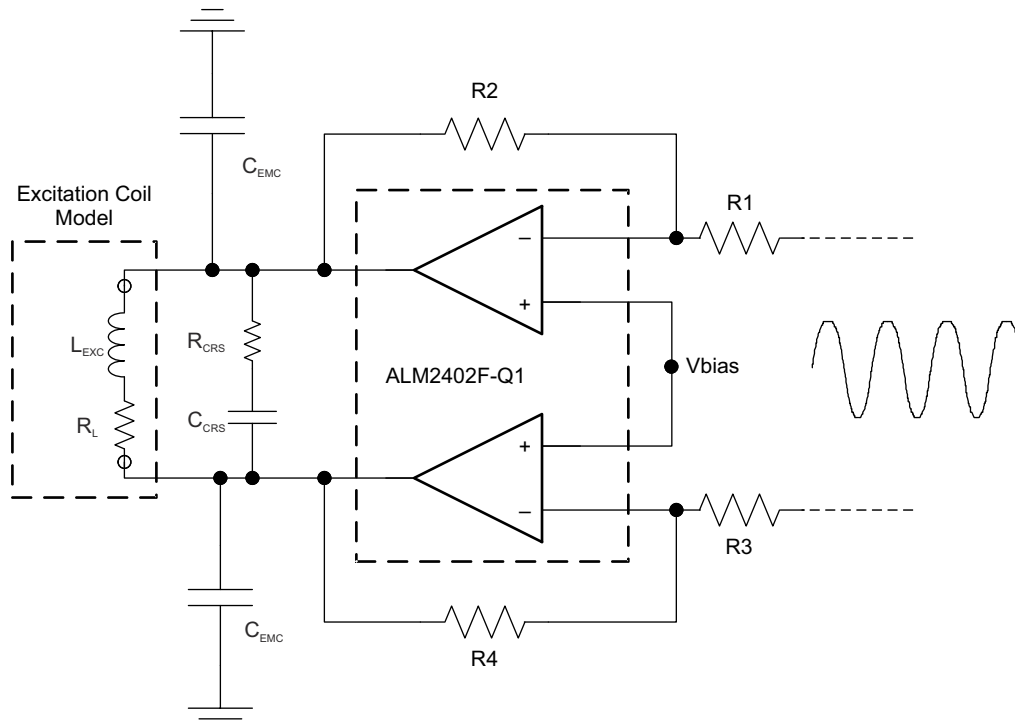
As mentioned in 节 8.2.2.1.2, the excitation signal is similar to a sampling pulse in ADCs, with the real information being in the envelope created by the rotor. Equation 3, Equation 4, and Equation 5 show the behavior of the sin and cos outputs. The excitation signal is attenuated and enveloped by the voltage created from the electromagnetic response of the rotating rotor. The resolver analog-output-to-digital converter filters out

the excitation signal, and processes the sine and cosine angles produced by the rotor. Hence, signal integrity or the sine and cosine envelope is most important in resolver design; although, some trade-offs in signal integrity of the excitation signal can be made for cost or convenience. Often, a square wave or sawtooth signal is used to accomplish excitation, as opposed to a sine wave.

$$V_{\text{EXC}} = V_{\text{PP}} \times \sin(2\pi ft) \quad (3)$$

$$V_{\text{SIN}} = T_{\text{R}} \times V_{\text{PP}} \times \sin(2\pi ft) \times \sin(\theta) \quad (4)$$

$$V_{\text{COS}} = T_{\text{R}} \times V_{\text{PP}} \times \sin(2\pi ft) \times \cos(\theta) \quad (5)$$

8.2.2.3 Power Dissipation and Thermal Reliability

Power dissipation is critical to many industrial and automotive applications. Resolvers are typically chosen over other position feedback techniques because of reliability and accuracy in harsh conditions and high temperatures.

The ALM2402F-Q1 is capable of high output current with power-supply voltages up to 16 V. Internal power dissipation increases when operating at high supply voltages. The power dissipated in the op amp (P_{OPA}) is calculated using Equation 6:

$$P_{\text{OPA}} = (V^+ - VO(X)) \times I_{\text{OUT}} = (V^+ - VO(X)) \times \frac{VO(X)}{R_{\text{L}}} \quad (6)$$

To calculate the worst-case power dissipation in the op amp, the ac and dc cases must be considered separately.

In the case of constant output current (dc) to a resistive load, the maximum power dissipation in the op amp occurs when the output voltage is half the positive supply voltage. This calculation assumes that the op amp is sourcing current from the positive supply to a grounded load. If the op amp sinks current from a grounded load, modify Equation 7 to include the negative supply voltage instead of the positive.

$$P_{\text{OPA(MAX_DC)}} = P_{\text{OPA}} \left(\frac{VO(X)}{2} \right) = \frac{(VO(X))^2}{4R_{\text{L}}} \quad (7)$$

The maximum power dissipation in the op amp for a sinusoidal output current (ac) to a resistive load occurs when the peak output voltage is $2/\pi$ times the supply voltage, given symmetrical supply voltages, as shown in Equation 8:

$$P_{\text{OPA(MAX_AC)}} = P_{\text{OPA}} \left(\frac{2VO(X)}{\pi} \right) = \frac{2 \cdot (VO(X))^2}{\pi^2 \cdot R_{\text{L}}} \quad (8)$$

After the total power dissipation is determined, the junction temperature at the worst expected ambient temperature case must be determined by using Equation 9:

$$T_{\text{J(MAX)}} = P_{\text{OPA}} \times R_{\theta\text{JA}} + T_{\text{A(MAX)}} \quad (9)$$

8.2.2.3.1 Improving Package Thermal Performance

The value of $R_{\theta\text{JA}}$ depends on the PCB layout. An external heat sink, a cooling mechanism such as a cold air fan, or both, can help reduce $R_{\theta\text{JA}}$ and thus improve device thermal capabilities. See TI's design support web page at www.ti.com/thermal for general guidance on improving device thermal performance.

8.2.3 Application Curves

The THD+N performance for the circuit described in the [Excitation Voltage](#) section is measured for a 10-kHz, 10-V_{PP} output signal from each op-amp channel. These measurement results are displayed in [表 8-2](#).

表 8-2. Maximum Output Power and THD+N

LOAD IMPEDANCE (Ω)	MAXIMUM OUTPUT POWER (mW)	THD+N AT MAXIMUM OUTPUT POWER (dB)
100	292	- 50

[图 8-4](#) shows the THD+N performance for different input signal frequencies with a measurement bandwidth of 80 kHz. [图 8-5](#) shows the circuit response with load capacitances of up to 100 nF. Using a larger resistor in series with the output, as shown in [节 8.1.1](#) further improves phase margin.

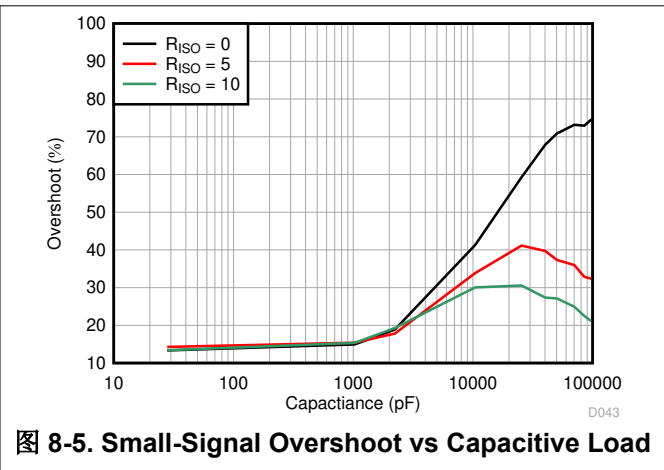
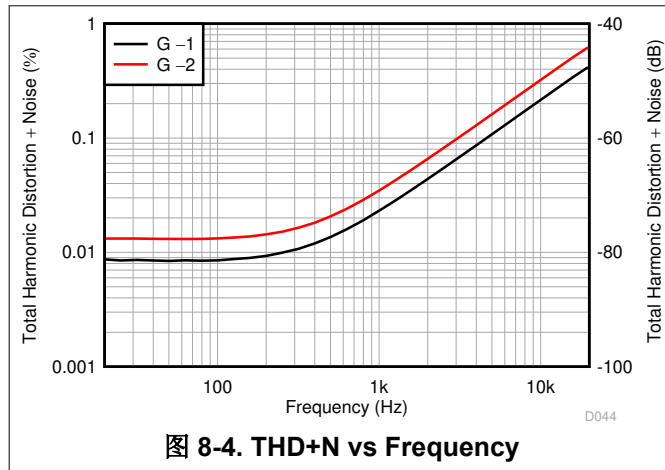

9 Power Supply Recommendations

The ALM2402F-Q1 is specified for continuous operation from 4.5 V to 16 V (± 2.25 V to ± 8 V) for V_{S_1} , and 3 V to 16V (± 1.5 V to ± 8 V) for $V_{S_{O(X)}}$; many specifications apply from -40°C to $+125^\circ\text{C}$.

Place 0.1- μF bypass capacitors close to the power-supply pins to reduce errors coupling in from noisy or high-impedance power supplies. For more detailed information on bypass capacitor placement, see the [Layout Guidelines](#) section.

CAUTION

Supply voltages larger than 18 V can permanently damage the device (see the [Absolute Maximum Ratings](#)).

10 Layout

10.1 Layout Guidelines

For best operational performance of the device, use good PCB layout practices, including:

- Noise can propagate into analog circuitry through the power pins of the circuit as a whole, as well as the operational amplifier. Bypass capacitors are used to reduce the coupled noise by providing low impedance power sources local to the analog circuitry.
 - Connect low-ESR, 0.1- μ F ceramic bypass capacitors between each supply pin and ground, placed as close as possible to the device. A single bypass capacitor from V+ to ground is applicable for single supply applications.
- Separate grounding for analog and digital portions of circuitry is one of the simplest and most-effective methods of noise suppression. One or more layers on multilayer PCBs are usually devoted to ground planes. A ground plane helps distribute heat and reduces EMI noise pickup. Make sure to physically separate digital and analog grounds, paying attention to the flow of the ground current. For more detailed information, see [Circuit Board Layout Techniques](#).
- To reduce parasitic coupling, run the input traces as far away as possible from the supply or output traces. If keeping the traces separate is not possible, then cross the sensitive trace perpendicular, as opposed to in parallel with the noisy trace.
- Keep the length of input traces as short as possible. Always remember that the input traces are the most sensitive part of the circuit.

10.2 Layout Example

This layout does not verify optimum thermal impedance performance. See TI's design support web page at www.ti.com/thermal for general guidance on improving device thermal performance.



图 10-1. ALM2402F-Q1 Layout Example

11 Device and Documentation Support

11.1 Documentation Support

11.1.1 Related Documentation

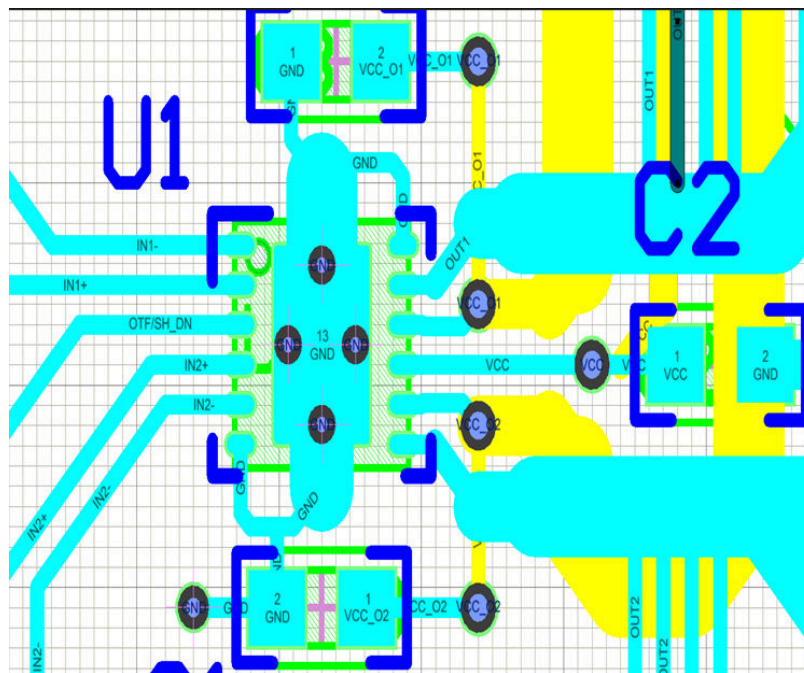
For related documentation see the following: Texas Instruments, [ALM2402F-Q1 Evaluation Module user's guide](#)

11.2 接收文档更新通知

要接收文档更新通知，请导航至 ti.com 上的器件产品文件夹。点击 [订阅更新](#) 进行注册，即可每周接收产品信息更改摘要。有关更改的详细信息，请查看任何已修订文档中包含的修订历史记录。

11.3 支持资源

[TI E2E™ 支持论坛](#) 是工程师的重要参考资料，可直接从专家获得快速、经过验证的解答和设计帮助。搜索现有解答或提出自己的问题可获得所需的快速设计帮助。

链接的内容由各个贡献者“按原样”提供。这些内容并不构成 TI 技术规范，并且不一定反映 TI 的观点；请参阅 TI 的《[使用条款](#)》。

11.4 Trademarks

TI E2E™ is a trademark of Texas Instruments.

所有商标均为其各自所有者的财产。

11.5 Electrostatic Discharge Caution



This integrated circuit can be damaged by ESD. Texas Instruments recommends that all integrated circuits be handled with appropriate precautions. Failure to observe proper handling and installation procedures can cause damage.

ESD damage can range from subtle performance degradation to complete device failure. Precision integrated circuits may be more susceptible to damage because very small parametric changes could cause the device not to meet its published specifications.

11.6 术语表

[TI 术语表](#) 本术语表列出并解释了术语、首字母缩略词和定义。

12 Mechanical, Packaging, and Orderable Information

The following pages include mechanical, packaging, and orderable information. This information is the most current data available for the designated devices. This data is subject to change without notice and revision of this document. For browser-based versions of this data sheet, refer to the left-hand navigation.

PACKAGING INFORMATION

Orderable Device	Status (1)	Package Type	Package Drawing	Pins	Package Qty	Eco Plan (2)	Lead finish/ Ball material (6)	MSL Peak Temp (3)	Op Temp (°C)	Device Marking (4/5)	Samples
ALM2402FQPWPRQ1	ACTIVE	HTSSOP	PWP	14	2000	RoHS & Green	NIPDAU	Level-3-260C-168 HR	-40 to 125	A2402FQ	Samples

(1) The marketing status values are defined as follows:

ACTIVE: Product device recommended for new designs.

LIFEBUY: TI has announced that the device will be discontinued, and a lifetime-buy period is in effect.

NRND: Not recommended for new designs. Device is in production to support existing customers, but TI does not recommend using this part in a new design.

PREVIEW: Device has been announced but is not in production. Samples may or may not be available.

OBSOLETE: TI has discontinued the production of the device.

(2) **RoHS:** TI defines "RoHS" to mean semiconductor products that are compliant with the current EU RoHS requirements for all 10 RoHS substances, including the requirement that RoHS substance do not exceed 0.1% by weight in homogeneous materials. Where designed to be soldered at high temperatures, "RoHS" products are suitable for use in specified lead-free processes. TI may reference these types of products as "Pb-Free".

RoHS Exempt: TI defines "RoHS Exempt" to mean products that contain lead but are compliant with EU RoHS pursuant to a specific EU RoHS exemption.

Green: TI defines "Green" to mean the content of Chlorine (Cl) and Bromine (Br) based flame retardants meet JS709B low halogen requirements of <=1000ppm threshold. Antimony trioxide based flame retardants must also meet the <=1000ppm threshold requirement.

(3) MSL, Peak Temp. - The Moisture Sensitivity Level rating according to the JEDEC industry standard classifications, and peak solder temperature.

(4) There may be additional marking, which relates to the logo, the lot trace code information, or the environmental category on the device.

(5) Multiple Device Markings will be inside parentheses. Only one Device Marking contained in parentheses and separated by a "-" will appear on a device. If a line is indented then it is a continuation of the previous line and the two combined represent the entire Device Marking for that device.

(6) Lead finish/Ball material - Orderable Devices may have multiple material finish options. Finish options are separated by a vertical ruled line. Lead finish/Ball material values may wrap to two lines if the finish value exceeds the maximum column width.

Important Information and Disclaimer:The information provided on this page represents TI's knowledge and belief as of the date that it is provided. TI bases its knowledge and belief on information provided by third parties, and makes no representation or warranty as to the accuracy of such information. Efforts are underway to better integrate information from third parties. TI has taken and continues to take reasonable steps to provide representative and accurate information but may not have conducted destructive testing or chemical analysis on incoming materials and chemicals. TI and TI suppliers consider certain information to be proprietary, and thus CAS numbers and other limited information may not be available for release.

In no event shall TI's liability arising out of such information exceed the total purchase price of the TI part(s) at issue in this document sold by TI to Customer on an annual basis.

TAPE AND REEL INFORMATION

QUADRANT ASSIGNMENTS FOR PIN 1 ORIENTATION IN TAPE

*All dimensions are nominal

Device	Package Type	Package Drawing	Pins	SPQ	Reel Diameter (mm)	Reel Width W1 (mm)	A0 (mm)	B0 (mm)	K0 (mm)	P1 (mm)	W (mm)	Pin1 Quadrant
ALM2402FQPWPRQ1	HTSSOP	PWP	14	2000	330.0	12.4	6.9	5.6	1.6	8.0	12.0	Q1

TAPE AND REEL BOX DIMENSIONS

*All dimensions are nominal

Device	Package Type	Package Drawing	Pins	SPQ	Length (mm)	Width (mm)	Height (mm)
ALM2402FQPWPRQ1	HTSSOP	PWP	14	2000	356.0	356.0	35.0

GENERIC PACKAGE VIEW

PWP 14

PowerPAD TSSOP - 1.2 mm max height

4.4 x 5.0, 0.65 mm pitch

PLASTIC SMALL OUTLINE

This image is a representation of the package family, actual package may vary.
Refer to the product data sheet for package details.

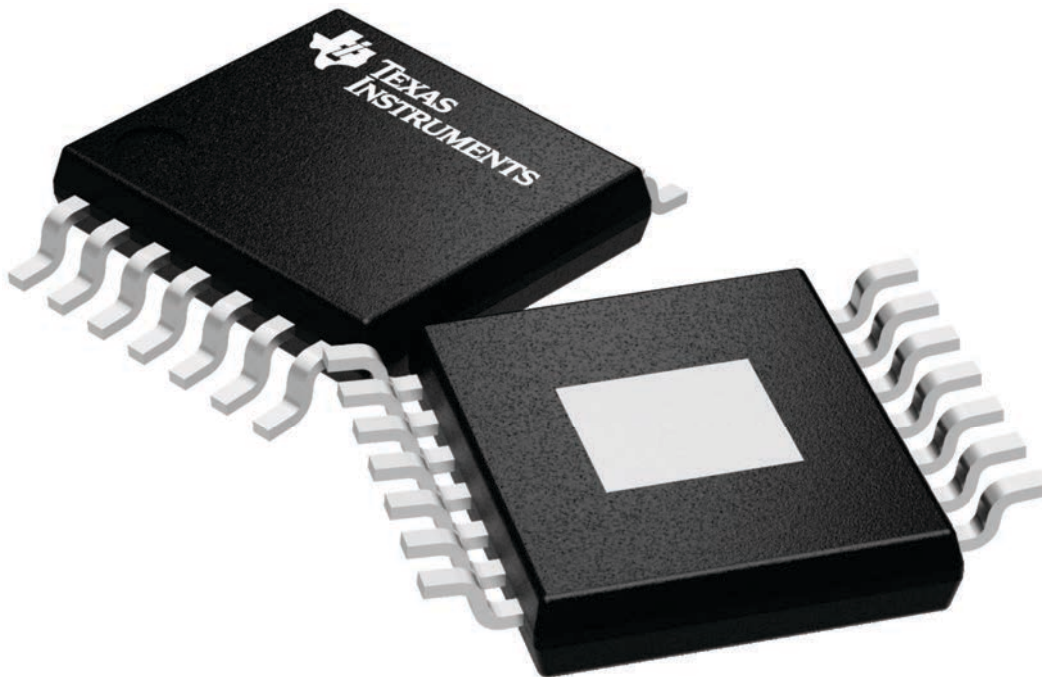

4224995/A

PWP0014H

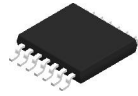

PACKAGE OUTLINE

PowerPAD™ TSSOP - 1.2 mm max height

PLASTIC SMALL OUTLINE

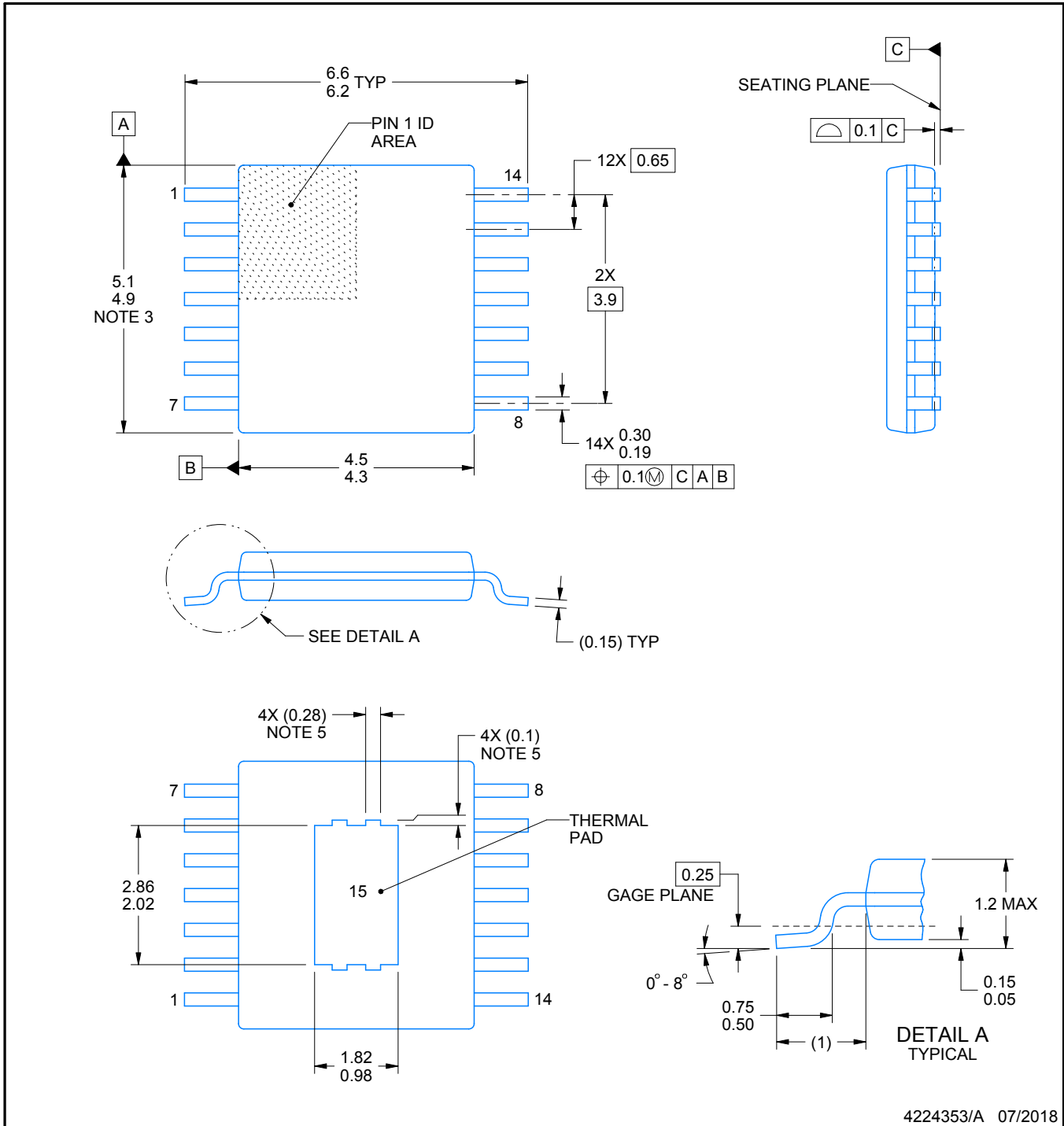

4224353/A 07/2018

NOTES:

PowerPAD is a trademark of Texas Instruments.

1. All linear dimensions are in millimeters. Any dimensions in parenthesis are for reference only. Dimensioning and tolerancing per ASME Y14.5M.
2. This drawing is subject to change without notice.
3. This dimension does not include mold flash, protrusions, or gate burrs. Mold flash, protrusions, or gate burrs shall not exceed 0.15 mm per side.
4. Reference JEDEC registration MO-153.
5. Features may differ and may not be present.

EXAMPLE BOARD LAYOUT

PWP0014H

PowerPAD™ TSSOP - 1.2 mm max height

PLASTIC SMALL OUTLINE

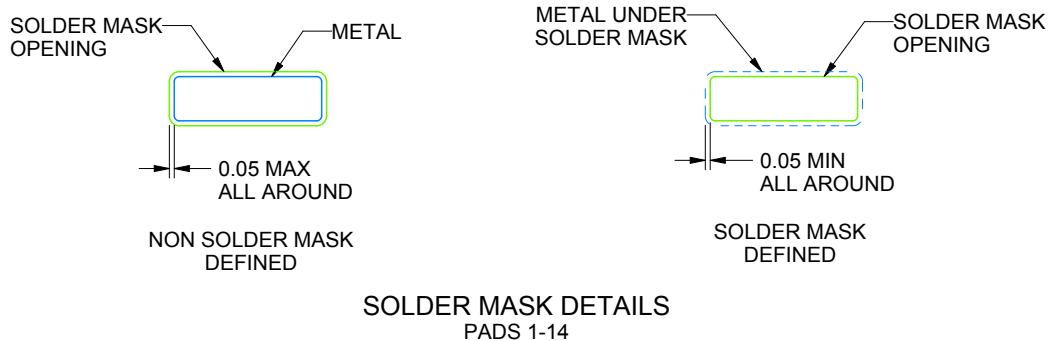
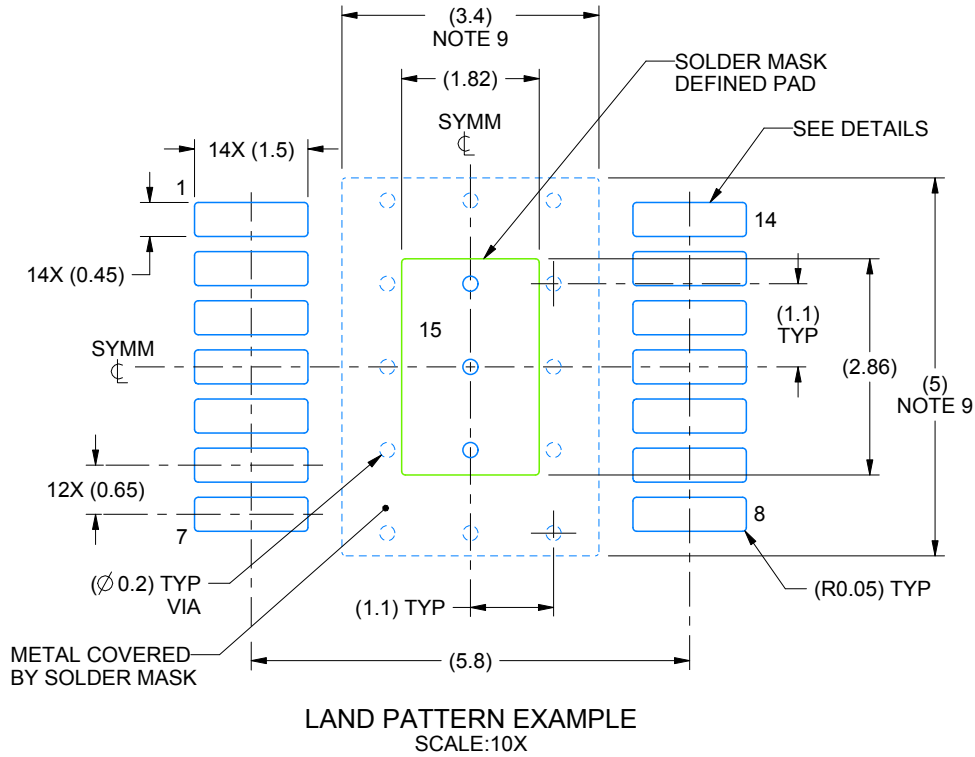

IA 07/2018

NOTES: (continued)

6. Publication IPC-7351 may have alternate designs.
7. Solder mask tolerances between and around signal pads can vary based on board fabrication site.
8. This package is designed to be soldered to a thermal pad on the board. For more information, see Texas Instruments literature numbers SLMA002 (www.ti.com/lit/slma002) and SLMA004 (www.ti.com/lit/slma004).
9. Size of metal pad may vary due to creepage requirement.

EXAMPLE STENCIL DESIGN

PWP0014H

PowerPAD™ TSSOP - 1.2 mm max height

PLASTIC SMALL OUTLINE

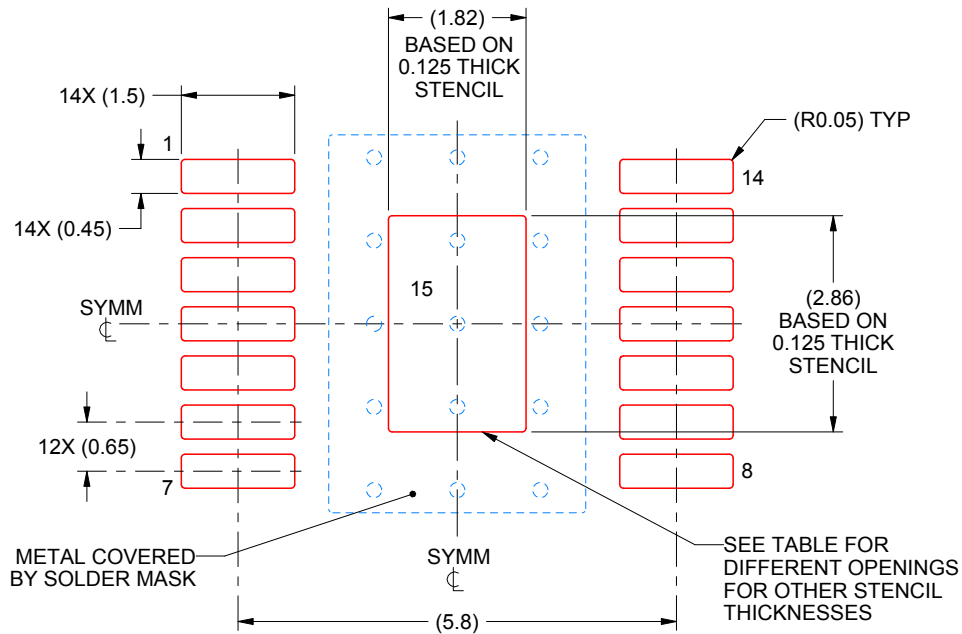

SOLDER PASTE EXAMPLE
EXPOSED PAD
100% PRINTED SOLDER COVERAGE BY AREA
SCALE:10X

STENCIL THICKNESS	SOLDER STENCIL OPENING
0.1	2.03 X 3.20
0.125	1.86 X 2.86 (SHOWN)
0.15	1.66 X 2.61
0.175	1.54 X 2.42

4224353/A 07/2018

NOTES: (continued)

10. Laser cutting apertures with trapezoidal walls and rounded corners may offer better paste release. IPC-7525 may have alternate design recommendations.
11. Board assembly site may have different recommendations for stencil design.

重要声明和免责声明

TI“按原样”提供技术和可靠性数据（包括数据表）、设计资源（包括参考设计）、应用或其他设计建议、网络工具、安全信息和其他资源，不保证没有瑕疵且不做任何明示或暗示的担保，包括但不限于对适销性、某特定用途方面的适用性或不侵犯任何第三方知识产权的暗示担保。

这些资源可供使用 TI 产品进行设计的熟练开发人员使用。您将自行承担以下全部责任：(1) 针对您的应用选择合适的 TI 产品，(2) 设计、验证并测试您的应用，(3) 确保您的应用满足相应标准以及任何其他功能安全、信息安全、监管或其他要求。

这些资源如有变更，恕不另行通知。TI 授权您仅可将这些资源用于研发本资源所述的 TI 产品的应用。严禁对这些资源进行其他复制或展示。您无权使用任何其他 TI 知识产权或任何第三方知识产权。您应全额赔偿因在这些资源的使用中对 TI 及其代表造成的任何索赔、损害、成本、损失和债务，TI 对此概不负责。

TI 提供的产品受 [TI 的销售条款](#) 或 [ti.com](#) 上其他适用条款/TI 产品随附的其他适用条款的约束。TI 提供这些资源并不会扩展或以其他方式更改 TI 针对 TI 产品发布的适用的担保或担保免责声明。

TI 反对并拒绝您可能提出的任何其他或不同的条款。

邮寄地址：Texas Instruments, Post Office Box 655303, Dallas, Texas 75265

Copyright © 2022，德州仪器 (TI) 公司

X-ON Electronics

Largest Supplier of Electrical and Electronic Components

Click to view similar products for [Precision Amplifiers](#) category:

Click to view products by [Texas Instruments](#) manufacturer:

Other Similar products are found below :

[LM201AN](#) [MCP6V52-E/MS](#) [ADA4692-4ARUZ-RL](#) [EL8176FSZ](#) [ISL28158FHZ-T7](#) [ISL28236FBZ](#) [ISL28236FBZ-T7](#) [ISL28258FUZ](#)
[ISL28258FUZ-T7](#) [ISL28276FBZ](#) [ISL28276IAZ](#) [ISL28276IAZ-T7](#) [ISL28288FUZ](#) [NCS21914DR2G](#) [NCS21914DTBR2G](#) [RS8654XP](#)
[AD8615AUJZ-REEL](#) [HG2376M/TR](#) [MS8362M](#) [LT1013IS8#TRPBF](#) [ADA4610-4ARZ-R7](#) [TP5591-TR](#) [AD8652ARZ-REEL](#) [AD8639ARZ-](#)
[REEL](#) [ADA4622-2ARZ-RL](#) [LTC6241HVCS8#TRPBF](#) [LT6011IS8#TRPBF](#) [LT6230IS6-10#TRPBF](#) [LT6011IMS8#TRPBF](#)
[LTC6246CS6#TRMPBF](#) [LT6230CS6#TRPBF](#) [ADA4610-2BRZ-RL](#) [LTC2054HS5#TRPBF](#) [LT6235IGN#TRPBF](#) [LTC6362IDD#TRPBF](#)
[AD8625ARUZ-REEL](#) [LTC2050HVIS8#TRPBF](#) [AD8627AKSZ-REEL](#) [LT6220IS5#TRPBF](#) [LT6236IS6#TRPBF](#) [OP213ESZ-REEL](#)
[ADA4092-4ARUZ-RL](#) [CBM8532AMS8](#) [CBM8628AST5](#) [CBM8534AS14](#) [CBM8608AS14](#) [CBM8534ATS14](#) [CBM8605AST5](#)
[CBM8629AS8](#) [CBM8608ATS14](#)