

BQ2057、BQ2057x 用于单节和两节锂离子和锂聚合物电池的高级线性充电管理 IC

1 特性

- 非常适合单节电池 (4.1V 或 4.2V) 和双节电池 (8.2V 或 8.4V) 锂离子或锂聚合物电池包
- 要求少量的外部元件
- 0.3V 压降电压, 可最大限度地降低热耗散
- 在预设电压下具有优于 $\pm 1\%$ 的电压调节精度
- **AutoCompM** 动态补偿电池包的内部阻抗, 可缩短充电时间
- 充电前和充电期间可选电芯温度监测
- 具有可编程充电电流和高侧或低侧电流检测功能的集成式电压和电流调节
- 集成式电芯调节功能可恢复深度放电的电芯, 并在充电的初始阶段更大限度地减少热耗散
- 用于一个或两个 LED 或主机处理器接口的充电状态输出
- 自动电池充电功能
- 以最小电流终止充电
- 移除 V_{CC} 时自动进入低功耗睡眠模式
- 可提供用于快速评估的 EVM
- 封装: 8 引脚 SOIC、8 引脚 TSSOP、8 引脚 MSOP

2 应用

- 紧急呼叫系统, 远程信息处理控制单元
- 售后市场远程信息处理
- 游戏和计算机配件
- 便携式医疗设备
- EPOS 读卡器

3 说明

BQ2057 系列高级锂离子 (Li-ion) 和锂聚合物 (Li-pol) 线性充电管理 IC 专为成本敏感型、紧凑型便携式电子

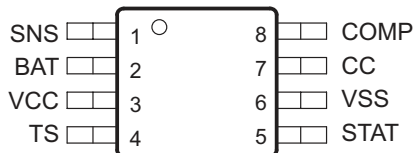

BQ2057xSN 或 BQ2057xTS SOIC (SN) 或 TSSOP (TS) 封装顶视图

产品而设计。它们将高精度电流和电压调节、电池调节、温度监控、充电终止、充电状态指示和 **AutoComp™** 充电速率补偿功能集成在一个 8 引脚 IC 中。提供 MSOP、TSSOP 和 SOIC 封装选项, 以适应广泛的终端应用。

BQ2057 使用外部热敏电阻持续测量电池温度。为安全起见, BQ2057 会在电池温度处于用户定义的阈值内之前禁止充电。然后, BQ2057 分三个阶段对电池进行充电: 调节、恒定电流和恒定电压。如果电池电压低于低电压阈值 $V_{(min)}$, BQ2057 将使用低电流进行预充电, 以调节电池。调节充电速率大概为调节电流的 10%。调节电流还可在充电的初始阶段更大限度地减少外部通道元件中的热耗散。调节后, BQ2057 向电池施加恒定电流。外部检测电阻器设置电流。检测电阻器可以位于电池的高侧或低侧, 无需额外的元件。恒定电流阶段一直持续到电池达到充电调节电压。

器件信息

器件型号	封装 ⁽¹⁾	封装尺寸 (标称值)
BQ2057C, BQ2057W	SOIC (8)	4.90mm × 3.91mm
BQ2057, BQ2057C, BQ2057T, BQ2057W	TSSOP (8)	3.00mm × 4.40mm
BQ2057, BQ2057C	MSOP (8) ⁽²⁾	3.00mm × 3.00mm

(1) 如需了解所有可用封装, 请参阅数据表末尾的可订购产品附录。

(2) 请注意该器件的引脚分配差异。

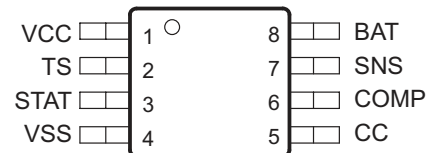

BQ2057xDGK MSOP DGK 封装顶视图



Table of Contents

1 特性.....	1	9.3 Feature Description.....	9
2 应用.....	1	10 Application and Implementation	11
3 说明.....	1	10.1 Application Information.....	11
4 Revision History	2	10.2 Typical Application.....	22
5 说明 (续).....	3	11 Power Supply Recommendations	24
6 Device Comparison Table	4	12 Layout	25
7 Pin Configuration and Functions	4	12.1 Layout Guidelines.....	25
8 Specifications	5	12.2 Layout Example.....	26
8.1 Absolute Maximum Ratings.....	5	13 Device and Documentation Support	28
8.2 ESD Ratings.....	5	13.1 Device Support.....	28
8.3 Recommended Operating Conditions.....	5	13.2 接收文档更新通知.....	28
8.4 Thermal Information.....	5	13.3 支持资源.....	28
8.5 Electrical Characteristics.....	6	13.4 Trademarks.....	28
8.6 Typical Characteristics.....	8	13.5 Electrostatic Discharge Caution.....	28
9 Detailed Description	9	13.6 术语表.....	28
9.1 Overview.....	9	14 Mechanical, Packaging, and Orderable Information	29
9.2 Functional Block Diagram.....	9		

4 Revision History

注：以前版本的页码可能与当前版本的页码不同

Changes from Revision F (July 2002) to Revision G (December 2022)	Page
• 添加了“ESD 等级”表、“特性说明”部分、“器件功能模式”、“应用和实施”部分、“电源相关建议”部分、“布局”部分、“器件和文档支持”部分以及“机械、封装和可订购信息”部分.....	1
• Updated Device Comparison Table.....	4
• Added thermal information.....	5
• Added typical characteristics curves.....	8
• Added figure to 节 10.2.....	22
• Added design requirements.....	22
• Added application curves.....	23
• Added Layout Guidelines subsections.....	25
• Added layout example.....	26

5 说明 (续)

然后，BQ2057 开始恒压阶段。在整个工作温度和电源电压范围内，电压调节的精度优于 $\pm 1\%$ 。对于单节和双节电池，BQ2057 提供四种固定电压版本：4.1V、4.2V、8.2V 和 8.4V。当电流逐渐达到充电终止阈值 $I_{(TERM)}$ 时，充电停止。如果电池电压低于 $V_{(RCH)}$ 阈值，BQ2057 会自动重新开始充电。

设计人员还可以使用 AutoComp 功能来缩短充电时间。这种专有技术允许在充电期间对电池包的内部阻抗进行安全、动态补偿。

6 Device Comparison Table

T _A	PACKAGE			
	CHARGE REGULATION VOLTAGE	SOIC (SN)	TSSOP (TS)	MSOP ⁽¹⁾ (DGK)
-20°C to 70°C	4.1 V	BQ2057SN	BQ2057TS	BQ2057DGK
	4.2 V	BQ2057CSN	BQ2057CTS	BQ2057CDGK
	8.2 V	BQ2057TSN	BQ2057TTS	Not available
	8.4 V	BQ2057WSN	BQ2057WTS	

(1) Note the difference in pinout for this package.

7 Pin Configuration and Functions



图 7-1. BQ2057xSN or BQ2057xTS SOIC (SN) or TSSOP (TS) Package Top View



图 7-2. BQ2057xDGK MSOP DGK Package Top View

表 7-1. Pin Functions-

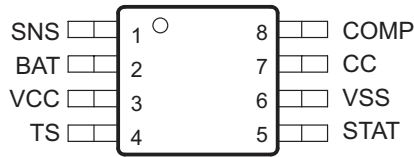
NAME	PIN NO.		I/O	DESCRIPTION
	SOIC (SN) and TSSOP (TS)	MSOP (DGK)		
	BAT	2		
CC	7	5	O	Charge control output
COMP	8	6	I	Charge-rate compensation input (AutoComp)
SNS	1	7	I	Current sense input
STAT	5	3	O	Charge status output
TS	4	2	I	Temperature sense input
VCC	3	1	I	Supply voltage
VSS	6	4	-	Ground

8 Specifications

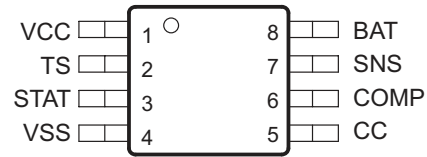
8.1 Absolute Maximum Ratings

over operating free-air temperature range (unless otherwise noted)⁽¹⁾

	MIN	MAX	UNIT
Supply voltage (V_{CC} with respect to GND)	-0.3	18	V
Input voltage, SNS, BAT, TS, COMP (all with respect to GND)	-0.3	$V_{CC}+0.3$	V
Sink current (STAT pin) not to exceed P_D		20	mA
Source current (STAT pin) not to exceed P_D		10	mA
Output current (CC pin) not to exceed P_D		40	mA
P_D Total power dissipation (at 25°C)		300	mW
T_A Operating free-air temperature range	- 20	70	°C
T_{stg} Storage temperature	- 40	125	°C

- (1) Stresses beyond those listed under *Absolute Maximum Ratings* may cause permanent damage to the device. These are stress ratings only, which do not imply functional operation of the device at these or any other conditions beyond those indicated under *Recommended Operating Conditions*. Exposure to absolute-maximum-rated conditions for extended periods may affect device reliability.

8.2 ESD Ratings

	VALUE	UNIT
$V_{(ESD)}$ Electrostatic discharge	Human-body model (HBM), per ANSI/ESDA/JEDEC JS-001 ⁽¹⁾	±2000
	Charged-device model (CDM), per JEDEC specification JESD22-C101 ⁽²⁾	±500

- (1) JEDEC document JEP155 states that 500-V HBM allows safe manufacturing with a standard ESD control process.
(2) JEDEC document JEP157 states that 250-V CDM allows safe manufacturing with a standard ESD control process.

8.3 Recommended Operating Conditions

over operating free-air temperature range (unless otherwise noted)

	MIN	NOM	MAX	UNIT
V_{CC} Supply voltage	4.5		15	V
T_A Operating free-air temperature range	- 20		70	°C

8.4 Thermal Information

THERMAL METRIC ⁽¹⁾	BQ2057xSN or BQ2057xTS	BQ2057xDGK MSOP	UNIT
	SOIC (SN) or TSSOP (TS) PACKAGE	DGK PACKAGE	
	8 PINS	8 PINS	
$R_{\theta JA}$ Junction-to-ambient thermal resistance	157.1	121.9	°C/W
$R_{\theta JC(top)}$ Junction-to-case (top) thermal resistance	46.5	58.8	°C/W
$R_{\theta JB}$ Junction-to-board thermal resistance	89.6	65.8	°C/W
ψ_{JT} Junction-to-top characterization parameter	3.3	12.8	°C/W
ψ_{JB} Junction-to-board characterization parameter	87.4	65.0	°C/W
$R_{\theta JC(bot)}$ Junction-to-case (bottom) thermal resistance	NA	NA	°C/W

- (1) For more information about traditional and new thermal metrics, see the *Semiconductor and IC Package Thermal Metrics* application report, [SPRA953](#).

8.5 Electrical Characteristics

over operating free-air temperature range (unless otherwise noted)

PARAMETER		TEST CONDITIONS	MIN	TYP	MAX	UNIT
$I_{(VCC)}$	V_{CC} Current	$V_{CC} > V_{CC(min)}$, Excluding external loads		2	4	mA
$I_{(VCCS)}$	V_{CC} Sleep current	For BQ2057 and BQ2957C, $V_{(BAT)} \geq V_{(min)}$, $V_{(BAT)} - V_{CC} \geq 0.8$ V		3	6	μ A
		For BQ2057T and BQ2957W, $V_{(BAT)} \geq V_{(min)}$, $V_{(BAT)} - V_{CC} \geq 0.8$ V			10	
$I_{(BAT)}$	Input bias current on BAT pin	$V_{(BAT)} = V_{(REG)}$			1	μ A
$I_{(SNS)}$	Input bias current on SNS pin	$V_{(SNS)} = 5$ V			5	μ A
$I_{(TS)}$	Input bias current on TS pin	$V_{(TS)} = 5$ V			5	μ A
$I_{(COMP)}$	Input bias current on COMP pin	$V_{(COMP)} = 5$ V			5	μ A
BATTERY VOLTAGE REGULATION						
$V_{(REG)}$	Output voltage	BQ2057, See (1) (2) (3)	4.059	4.10	4.141	V
		BQ2057C, See (1) (2) (3)	4.158	4.20	4.242	
		BQ2057T, See (1) (2) (3)	8.119	8.20	8.282	
		BQ2057W, See (1) (2) (3)	8.317	8.40	8.484	
CURRENT REGULATION						
$V_{(SNS)}$	Current regulation threshold	BQ2057 and BQ2057C, High-side current sensing configuration	95.4	105	115.5	mV
		BQ2057T and BQ2057W, High-side current sensing configuration	103.6	125	137.5	
		BQ2057 and BQ2057C, Low-side current sensing configuration	100	110	121	
		BQ2057T and BQ2057W, Low-side current sensing configuration	108.1	130	143	
CHARGE TERMINATION DETECTION						
$I_{(TERM)}$	Charge termination current detect threshold	Voltage at pin SNS, relative to V_{CC} for high-side sensing, and to V_{SS} for low-side sensing, $0^{\circ}\text{C} \leq T_A \leq 50^{\circ}\text{C}$	-30	-14	-4	mV
TEMPERATURE COMPARATOR						
$V_{(TS1)}$	Lower temperature threshold	TS pin voltage	29.1	30	30.9	%VCC
$V_{(TS2)}$	Upper temperature threshold		58.3	60	61.8	
PRECHARGE COMPARATOR						
$V_{(min)}$	Precharge threshold	BQ2057	2.94	3	3.06	V
		BQ2057C	3.04	3.1	3.16	
		BQ2057T	5.9	6.1	6.22	
		BQ2057W	6.18	6.3	6.43	
PRECHARGE CURRENT REGULATION						
$I_{(PRECHG)}$	Precharge current regulation	Voltage at pin SNS, relative to V_{CC} for high-side sensing, and to V_{SS} for low-side sensing, $0^{\circ}\text{C} \leq T_A \leq 50^{\circ}\text{C}$		13		mV
		Voltage at pin SNS, relative to V_{CC} for high-side sensing, $0^{\circ}\text{C} \leq T_A \leq 50^{\circ}\text{C}$, $V_{CC} = 5$ V	3	13	22	mV
$V_{(RCH)}$ COMPARATOR (Battery Recharge Threshold)						
$V_{(RCH)}$	Recharge threshold	BQ2057 and BQ2057C	$V_{(REG)} - 98$ mV	$V_{(REG)} - 100$ mV	$V_{(REG)} - 102$ mV	V
		BQ2057T and BQ2057W	$V_{(REG)} - 196$ mV	$V_{(REG)} - 200$ mV	$V_{(REG)} - 204$ mV	V
CHARGE-RATE COMPENSATION (AutoComp)						
$G_{(COMP)}$	AutoComp gain	$V_{(BAT)} + 0.3$ V $\leq V_{CC} \leq V_{CC(max)}$, BQ2057, BQ2057C, BQ2057T, BQ2057W	1.87	2.2	2.53	V/V
		$V_{(BAT)} + 0.3$ V $\leq V_{CC} \leq V_{CC(max)}$, BQ2057T and BQ2057W in low-side sensing configuration	2.09	2.4	2.76	
STAT PIN						

8.5 Electrical Characteristics (continued)

over operating free-air temperature range (unless otherwise noted)

PARAMETER		TEST CONDITIONS	MIN	TYP	MAX	UNIT
V _{OL(STAT)}	Output (low) voltage	I _{OL} = 10 mA			0.7	V
V _{OH(STAT)}	Output (high) voltage	I _{OH} = 5 mA	V _{CC} - 0.5			
CC PIN						
V _{OL(CC)}	Output low voltage	I _{O(CC)} = 5 mA (sink)			1.5	V
I _{O(CC)}	Sink current	Not to exceed power rating specification (P _D)	5		40	mA

- (1) For high-side current sensing configuration.
- (2) For low-side current sensing configuration, the tolerance is ±1% for T_A = 25°C and ±1.2% for -20°C ≥ T_A ≥ 70°C.
- (3) V_(BAT)+0.3 V ≤ V_{CC} ≤ V_{CC(max)}

8.6 Typical Characteristics

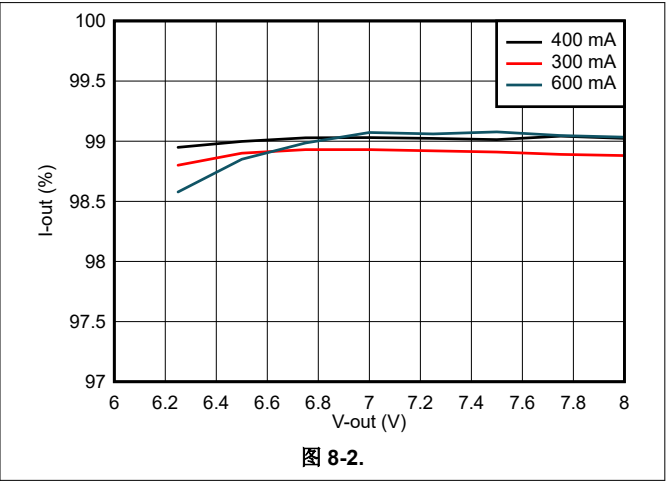
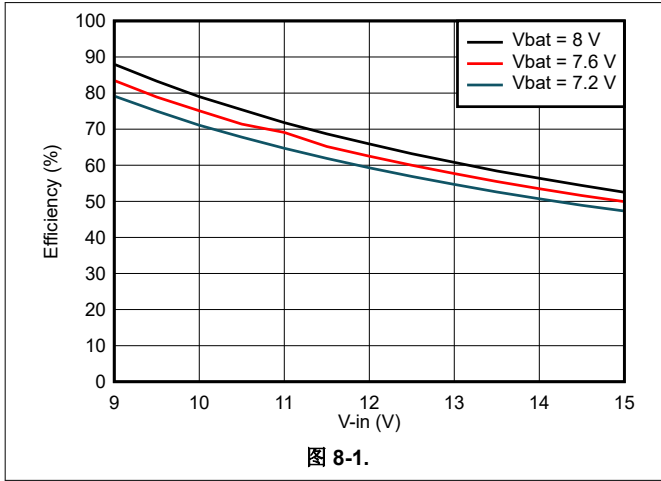

9 Detailed Description

9.1 Overview

Descriptions of the devices are presented in the following sections.

9.2 Functional Block Diagram

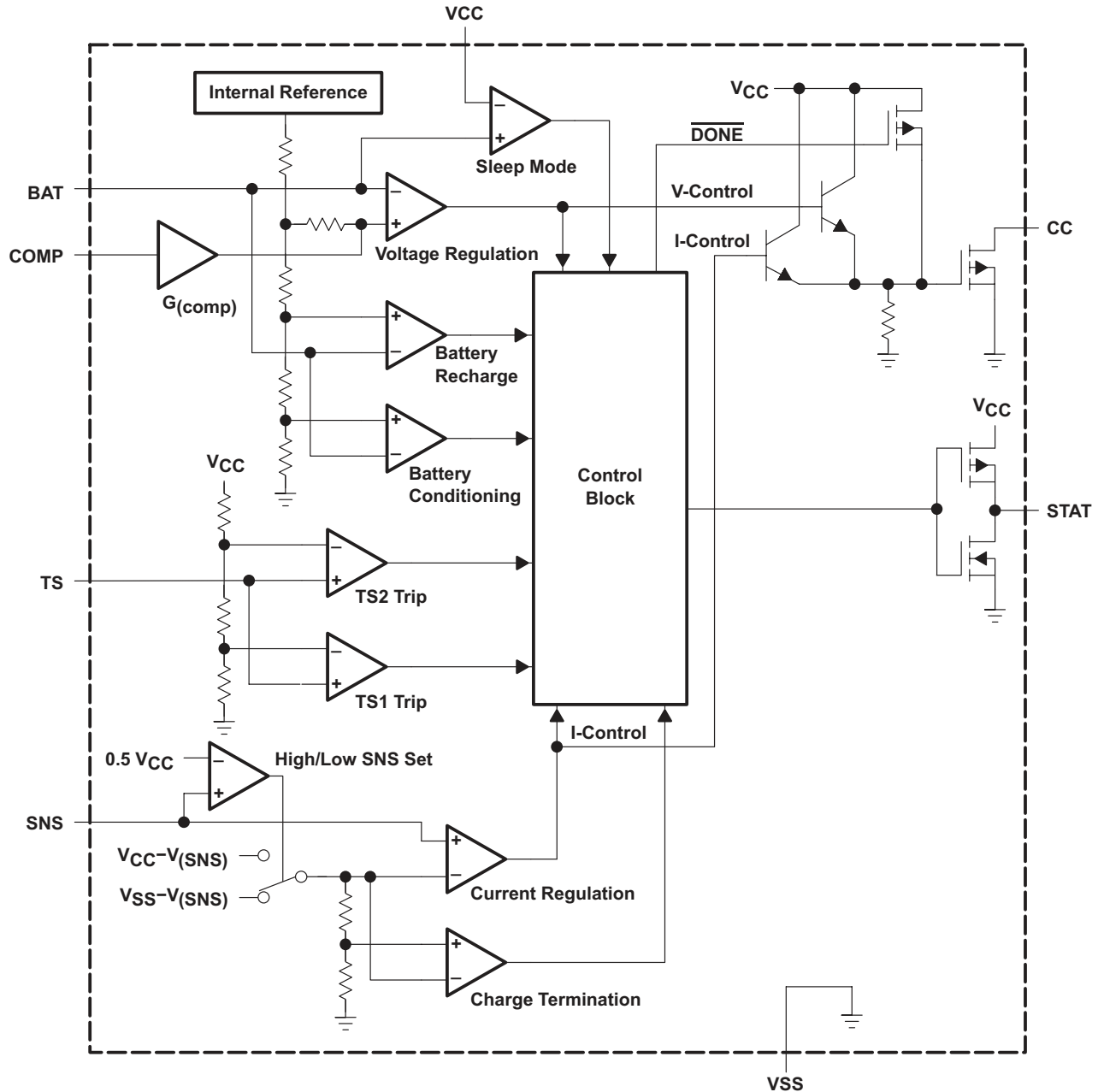

9.3 Feature Description

9.3.1 Current-Sense Input

Battery current is sensed via the voltage developed on this pin by an external sense resistor. The external resistor can be placed on either the high or low side of the battery. (See schematics for details.)

9.3.2 Battery-Voltage Input

Voltage sense-input tied directly to the positive side of the battery.

9.3.3 Temperature Sense Input

Input for an external battery-temperature monitoring circuit. Connecting this input to VCC/2 disables this feature.

9.3.4 Charge-status Output

Three-state indication of charge in progress, charge complete, and temperature fault or sleep mode.

9.3.5 Charge-Control Output

Source-follower output that drives an external pass-transistor (PNP or P-channel MOSFET) for current and voltage regulation.

9.3.6 Charge-Rate Compensation Input

Sets the charge-rate compensation level. The voltage-regulation output may be programmed to vary as a function of the charge current delivered to the battery.

9.3.7 Supply Voltage Input

Power supply input and current reference for high-side sensing configuration.

10 Application and Implementation

备注

Information in the following applications sections is not part of the TI component specification, and TI does not warrant its accuracy or completeness. TI's customers are responsible for determining suitability of components for their purposes. Customers should validate and test their design implementation to confirm system functionality.

10.1 Application Information

10.1.1 Functional Description

The BQ2057 is an advanced linear charge controller for single or two-cell Li-Ion or Li-Pol applications. 图 10-1 shows the schematic of charger using a PNP pass transistor. 图 10-2 is an operational state diagram, and 图 10-3 is a typical charge profile. 图 10-4 shows the schematic of a charger using P-channel MOSFET.



图 10-1. Low Dropout Single- or Two-Cell Li-Ion/Li-Pol Charger



图 10-2. Operation Flowchart

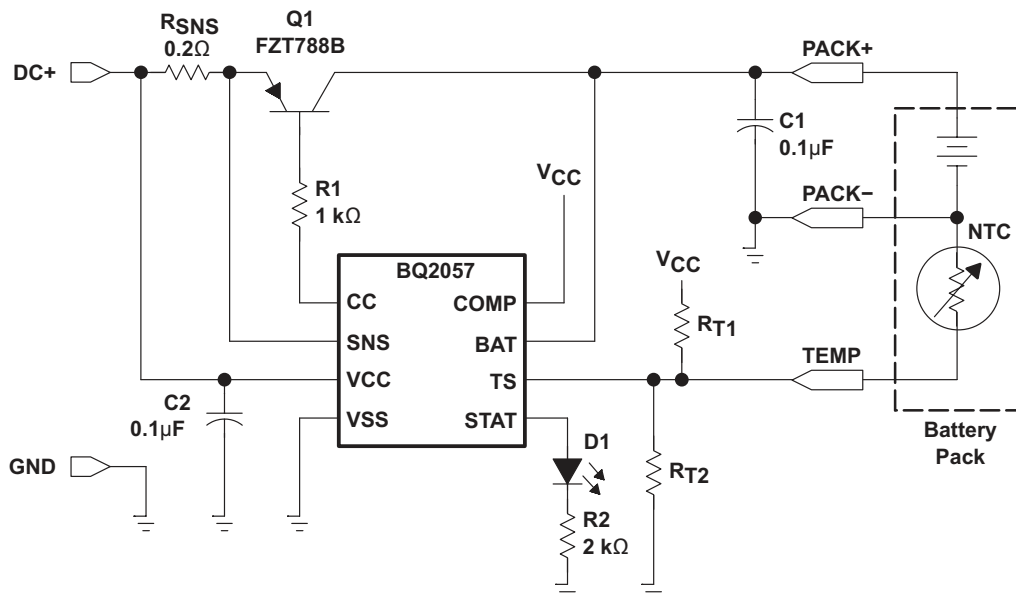

图 10-3. Typical Charge Profile

10.1.2 Qualification and Precharge

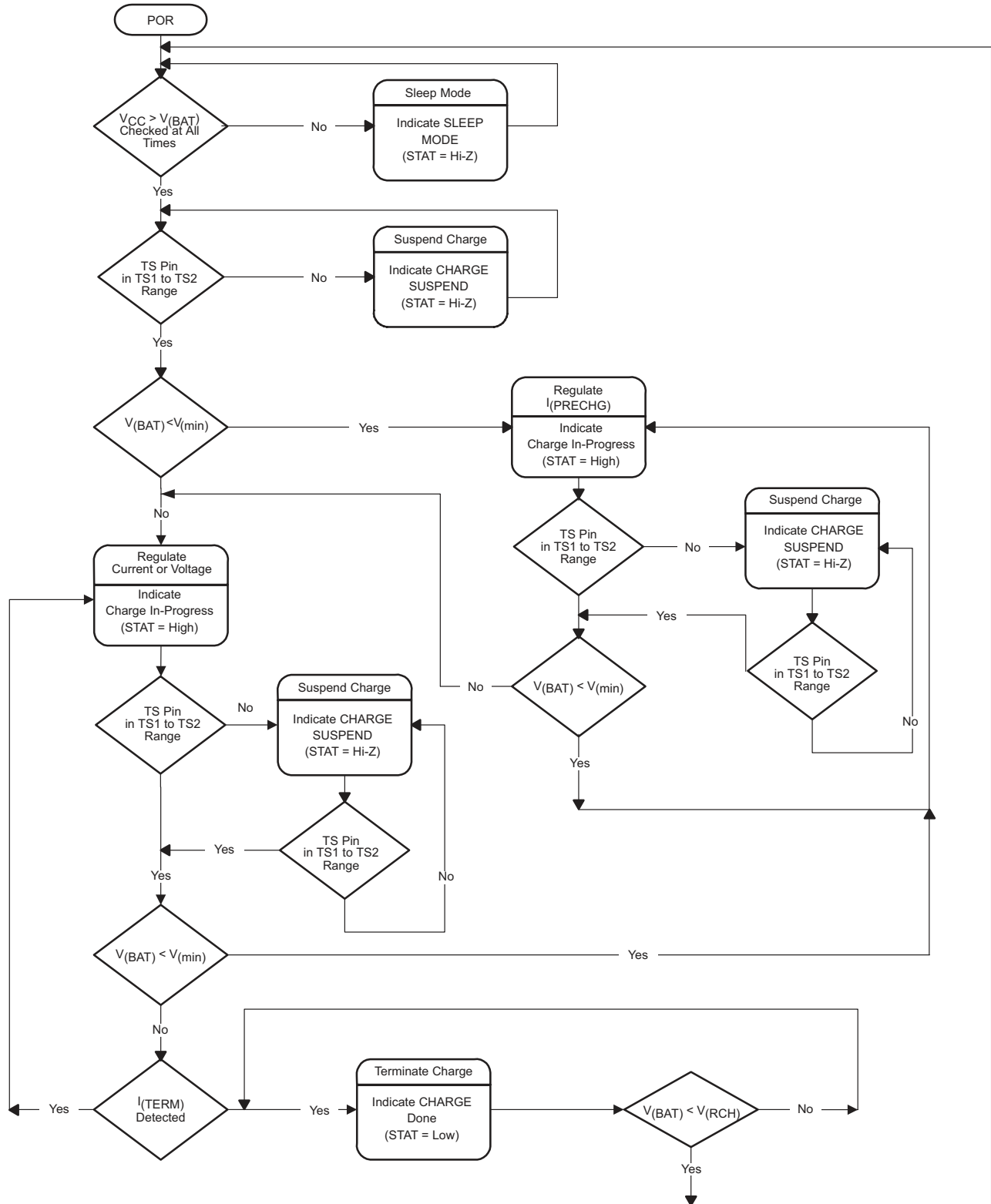
When power is applied, the BQ2057 starts a charge-cycle if a battery is already present or when a battery is inserted. Charge qualification is based on battery temperature and voltage. The BQ2057 suspends charge if the battery temperature is outside the $V_{(TS1)}$ to $V_{(TS2)}$ range and suspends charge until the battery temperature is within the allowed range. The BQ2057 also checks the battery voltage. If the battery voltage is below the precharge threshold $V_{(min)}$, the BQ2057 uses precharge to condition the battery. The conditioning charge rate $I_{(PRECHG)}$ is set at approximately 10% of the regulation current. The conditioning current also minimizes heat dissipation in the external pass-element during the initial stage of charge. See 图 10-3 for a typical charge-profile.

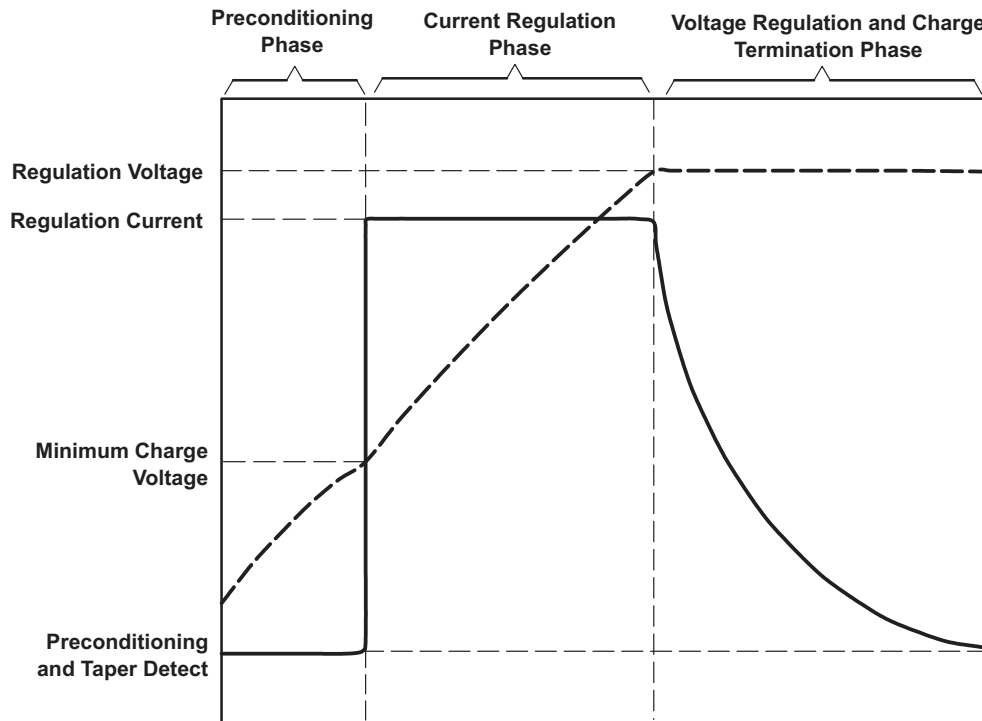

图 10-4. 0.5-A Charger Using P-Channel MOSFET

10.1.3 Current Regulation Phase

The BQ2057 regulates current while the battery-pack voltage is less than the regulation voltage, $V_{O(REG)}$. The BQ2057 monitors charge current at the SNS input by the voltage drop across a sense-resistor, R_{SNS} , in series with the battery pack. In high-side current sensing configuration (see 图 10-5), R_{SNS} is between the VCC and SNS pins, and in low-side sensing (see 图 10-6) the R_{SNS} is between VSS (battery negative) and SNS (charger ground) pins. Charge-current feedback, applied through pin SNS, maintains a voltage of $V_{(SNS)}$ across the current sense resistor. Equation 1 calculates the value of the sense resistor:

$$R_{SNS} = \frac{V_{(SNS)}}{I_{O(REG)}} \quad (1)$$

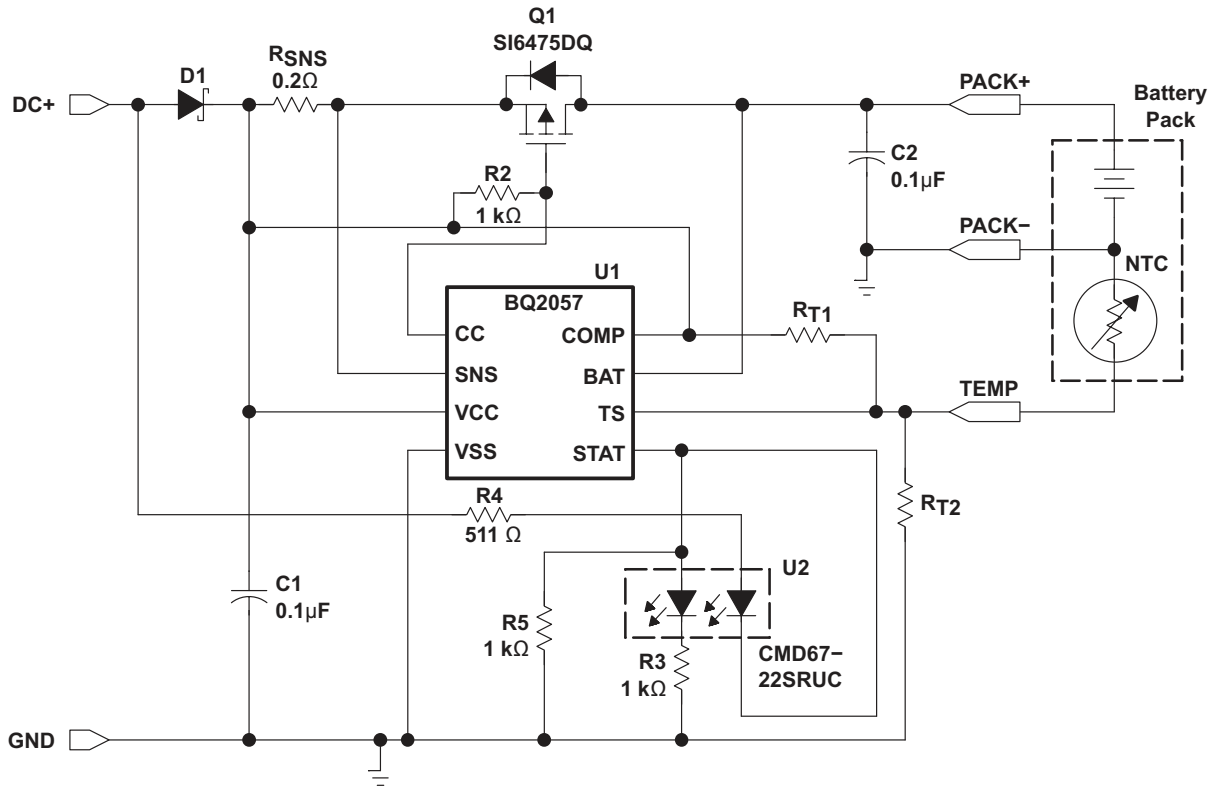
Where $I_{O(REG)}$ is the desired charging current.



图 10-5. High-Side Current Sensing



图 10-6. Low-Side Current Sensing

10.1.4 Voltage Regulation Phase

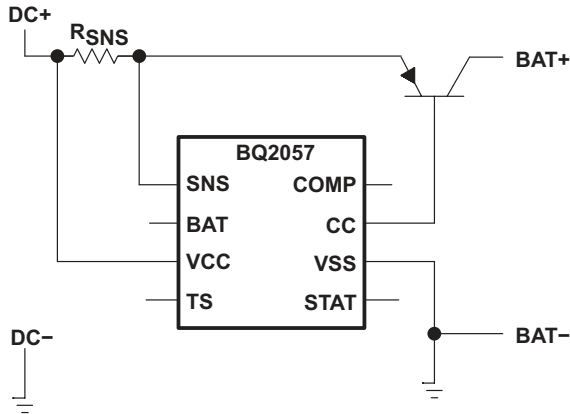
The voltage regulation feedback is through the BAT pin. This input is tied directly to the positive side of the battery pack. The BQ2057 monitors the battery-pack voltage between the BAT and VSS pins. The BQ2057 is offered in four fixed-voltage versions: 4.1 V, 4.2 V, 8.2 V, and 8.4 V.

Other regulation voltages can be achieved by adding a voltage divider between the positive and negative terminals of the battery pack and using BQ2057T or BQ2057W. The voltage divider presents scaled battery-pack voltage to BAT input. (See 图 10-7 and 图 10-8.) The resistor values RB1 and RB2 for the voltage divider are calculated by the following equation:

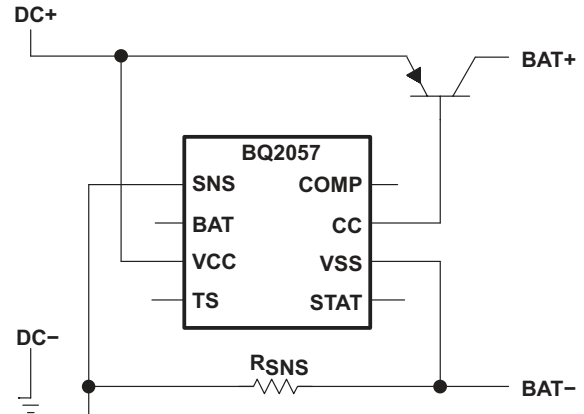
$$\frac{R_{B1}}{R_{B2}} = \left(N \times \frac{V_{(CELL)}}{V_{O(REG)}} \right) - 1 \quad (2)$$

Where:

N = Number of cells in series

$V_{(CELL)}$ = Desired regulation voltage per cell



图 10-7. Optional Voltage Divider for Nonstandard Regulation Voltage, (High-Side Current Sensing)



图 10-8. Optional Voltage Divider for Nonstandard Regulation Voltage, (Low-Side Current Sensing)

10.1.5 Charge Termination and Recharge

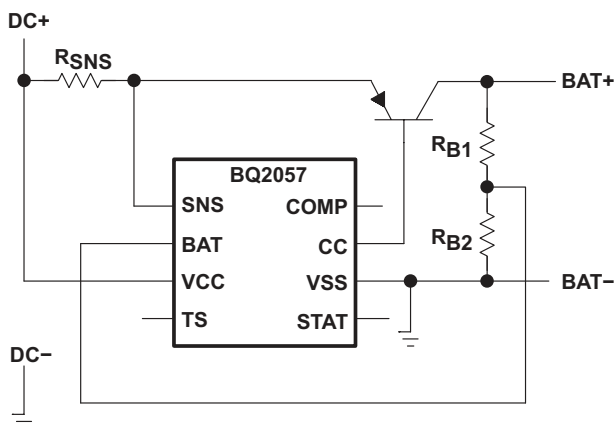
The BQ2057 monitors the charging current during the voltage-regulation phase. The BQ2057 declares a done condition and terminates charge when the current tapers off to the charge termination threshold, $I_{(TERM)}$. A new charge cycle begins when the battery voltage falls below the $V_{(RCH)}$ threshold.

10.1.6 Battery Temperature Monitoring

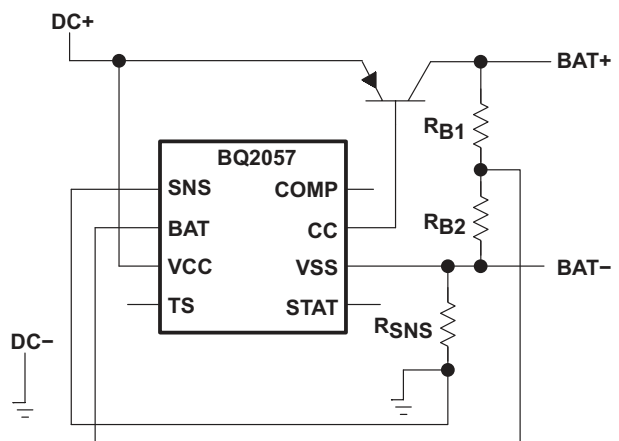
The BQ2057 continuously monitors temperature by measuring the voltage between the TS and VSS pins. A negative- or a positive-temperature coefficient thermistor (NTC, PTC) and an external voltage divider typically develop this voltage. (See [Figure 10-9](#).) The BQ2057 compares this voltage against its internal $V_{(TS1)}$ and $V_{(TS2)}$ thresholds to determine if charging is allowed. (See [Figure 10-10](#).) The temperature sensing circuit is immune to any fluctuation in V_{CC} , since both the external voltage divider and the internal thresholds ($V_{(TS1)}$ and $V_{(TS2)}$) are referenced to VCC.

The resistor values of $R_{(T1)}$ and $R_{(T2)}$ are calculated by the following equations:

For NTC Thermistors

$$R_{T1} = \frac{5 \times R_{TH} \times R_{TC}}{3 \times (R_{TC} - R_{TH})} \quad (3)$$

$$R_{T1} = \frac{5 \times R_{TH} \times R_{TC}}{3 \times (R_{TC} - R_{TH})} \quad (4)$$

For PTC Thermistors

$$R_{T1} = \frac{5 \times R_{TH} \times R_{TC}}{3 \times (R_{TH} - R_{TC})} \quad (5)$$

$$R_{T2} = \frac{5 \times R_{TH} \times R_{TC}}{\left[(2 \times R_{TH}) - (7 \times R_{TC}) \right]} \quad (6)$$

Where $R_{(TC)}$ is the cold temperature resistance and $R_{(TH)}$ is the hot temperature resistance of thermistor, as specified by the thermistor manufacturer.

R_{T1} or R_{T2} can be omitted if only one temperature (hot or cold) setting is required. Applying a voltage between the $V_{(TS1)}$ and $V_{(TS2)}$ thresholds to pin TS disables the temperature-sensing feature.



图 10-9. Temperature Sensing Circuits



图 10-10. BQ2057 TS Input Thresholds

10.1.7 Charge Inhibit Function

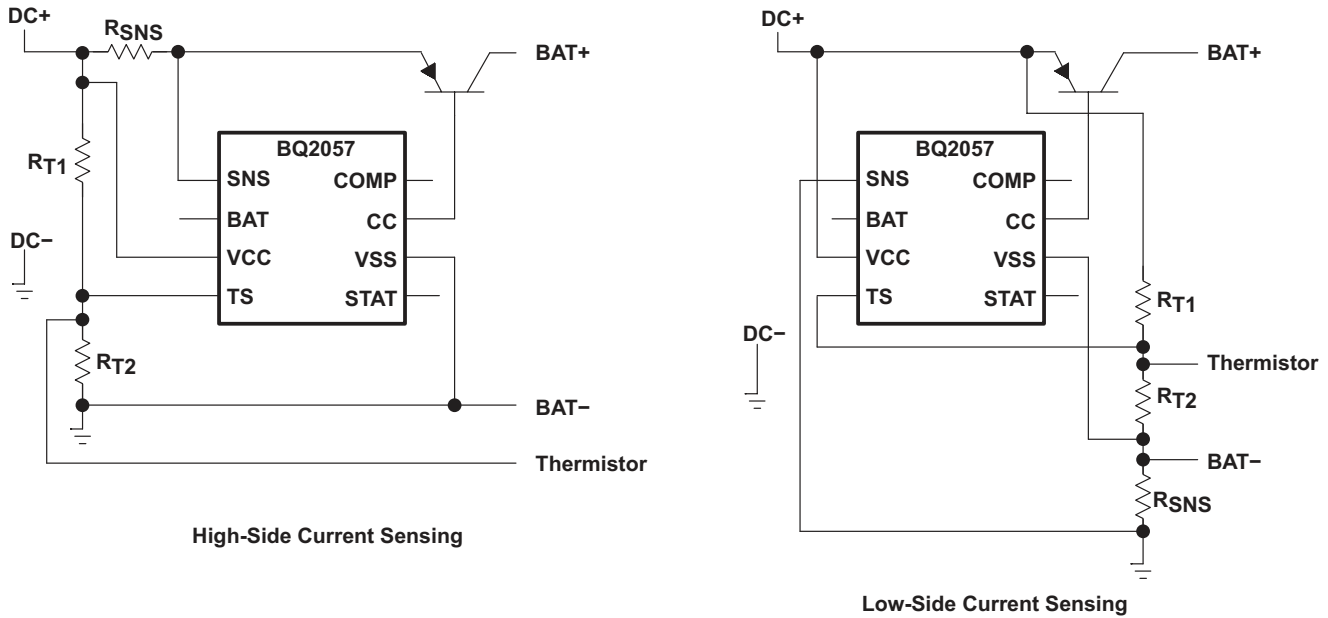
The TS pin can be used as charge-inhibit input. The user can inhibit charge by connecting the TS pin to VCC or VSS (or any level outside the $V_{(TS1)}$ to $V_{(TS2)}$ thresholds). Applying a voltage between the $V_{(TS1)}$ and $V_{(TS2)}$ thresholds to pin TS returns the charger to normal operation.

10.1.8 Charge Status Indication

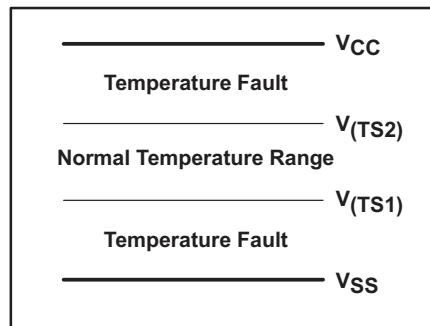
The BQ2057 reports the status of the charger on the 3-state STAT pin. The following table summarized the operation of the STAT pin.

CONDITION	STAT PIN
Battery conditioning and charging	High
Charge complete (Done)	Low
Temperature fault or sleep mode	Hi-Z

The STAT pin can be used to drive a single LED (图 10-1), dual-chip LEDs (Figure 4) or for interface to a host or system processor (图 10-11). When interfacing the BQ2057 to a processor, the user can use an output port, as shown in 图 10-11, to recognize the Hi-Z state of the STAT pin. In this configuration, the user needs to read the input pin, toggle the output port and read the STAT pin again. In a Hi-Z condition, the input port always matches the signal level on the output port.



图 10-11. Interfacing the BQ2057 to a Host Processor

10.1.9 Low-power Sleep Mode

The BQ2057 enters the sleep mode if the VCC falls below the voltage at the BAT input. This feature prevents draining the battery pack during the absence of VCC.

10.1.10 Selecting an External Pass-Transistor

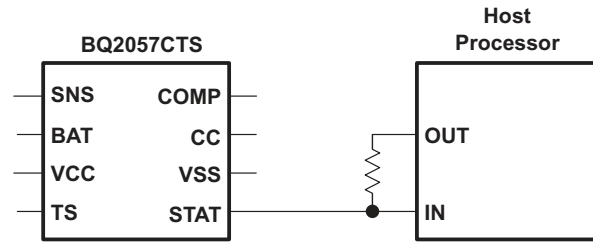
The BQ2057 is designed to work with both PNP transistor and P-channel MOSFET. The device should be chosen to handle the required power dissipation, given the circuit parameters, PCB layout and heat sink configuration. The following examples illustrate the design process for either device:

PNP transistor: Selection steps for a PNP bipolar transistor: Example: $V_I = 4.5\text{ V}$, $I_{(REG)} = 1\text{ A}$, 4.2-V single-cell Li-Ion (bq2057C). V_I is the input voltage to the charger and $I_{(REG)}$ is the desired charge current (see 图 10-1).

1. Determine the maximum power dissipation, P_D , in the transistor. The worst case power dissipation happens when the cell voltage, $V_{(BAT)}$, is at its lowest (typically 3 V at the beginning of current regulation phase) and V_I is at its maximum.

Where V_{CS} is the voltage drop across the current sense resistor.

$$P_D = (V_I - V_{CS} - V_{(BAT)}) \times I_{REG}$$

$$P_D = (4.5 - 0.1 - 3) \times 1\text{ A}$$

$$P_D = 1.4\text{ W}$$

(7)

2. Determine the package size needed in order to keep the junction temperature below the manufacturer's recommended value, $T_{(J)max}$. Calculate the total theta, θ ($^{\circ}\text{C}/\text{W}$), needed.

$$\theta_{JC} = \frac{(T_{(J)max} - T_{A(max)})}{P_D}$$

$$\theta_{JC} = \frac{(150 - 40)}{1.4}$$

$$\theta_{JC} = 78^{\circ}\text{C} / \text{W}$$

(8)

Now choose a device package with a theta at least 10% below this value to account for additional thetas other than the device. A SOT223 package, for instance, has typically a theta of $60^{\circ}\text{C}/\text{W}$.

3. Select a collector-emitter voltage, $V_{(CE)}$, rating greater than the maximum input voltage. A 15-V device will be adequate in this example.
4. Select a device that has at least 50% higher drain current I_C rating than the desired charge current $I_{(REG)}$.
5. Using Equation 9, calculate the minimum beta (β or h_{FE}) needed:

$$\beta_{min} = \frac{I_{CMAX}}{I_B}$$

$$\beta_{min} = \frac{1}{0.035}$$

$$\beta_{min} = 28$$

(9)

where $I_{\max(C)}$ is the maximum collector current (in this case same as $I_{(REG)}$), and I_B is the base current (chosen to be 35 mA in this example).

备注

The beta of a transistor drops off by a factor of 3 over temperature and also drops off with load. Therefore, note the beta of device at $I_{(REG)}$ and the minimum ambient temperature when choosing the device. This beta should be larger than the minimum required beta.

Now choose a PNP transistor that is rated for $V_{(CE)} \geq 15\text{ V}$, $\theta_{JC} \leq 78^\circ\text{C/W}$, $I_C \geq 1.5\text{ A}$, $\beta_{\min} \geq 28$ and that is in a SOT223 package.

P-channel MOSFET: Selection steps for a P-channel MOSFET: Example: $V_I = 5.5\text{ V}$, $I_{(REG)} = 500\text{ mA}$, 4.2-V single-cell Li-Ion (BQ2057C). V_I is the input voltage to the charger and $I_{(REG)}$ is the desired charge current. (See [图 10-4](#).)

1. Determine the maximum power dissipation, P_D , in the transistor.
The worst case power dissipation happens when the cell voltage, $V_{(BAT)}$, is at its lowest (typically 3 V at the beginning of current regulation phase) and V_I is at its maximum.
Where V_D is the forward voltage drop across the reverse-blocking diode (if one is used), and V_{CS} is the voltage drop across the current sense resistor.

$$P_D = (V_I - V_D - V_{(CS)} - V_{(BAT)}) \times I_{(REG)}$$

$$P_D = (5.5 - 0.4 - 0.1 - 3) \times 0.5\text{ A}$$

$$P_D = 1\text{ W} \tag{10}$$

2. Determine the package size needed in order to keep the junction temperature below the manufacturer's recommended value, T_{JMAX} . Calculate the total theta, θ ($^\circ\text{C/W}$), needed.

$$\theta_{JC} = \frac{(T_{\max(J)} - T_{A(\max)})}{P_D}$$

$$\theta_{JC} = \frac{(150 - 40)}{1}$$

$$\theta_{JC} = 110^\circ\text{C/W} \tag{11}$$

Now choose a device package with a theta at least 10% below this value to account for additional thetas other than the device. A TSSOP-8 package, for instance, has typically a theta of 70°C/W .

3. Select a drain-source voltage, $V_{(DS)}$, rating greater than the maximum input voltage. A 12-V device will be adequate in this example.
4. Select a device that has at least 50% higher drain current (I_D) rating than the desired charge current $I_{(REG)}$.
5. Verify that the available drive is large enough to supply the desired charge current.

$$V_{(GS)} = (V_D + V_{(CS)} + V_{OL(CC)}) - V_I$$

$$V_{(GS)} = (0.4 + 0.1 + 1.5) - 5.5$$

$$V_{(GS)} = -3.5 \tag{12}$$

Where $V_{(GS)}$ is the gate-to-source voltage, V_D is the forward voltage drop across the reverse-blocking diode (if one is used), and V_{CS} is the voltage drop across the current sense resistor, and $V_{OL(CC)}$ is the CC pin output low voltage specification for the BQ2057.

Select a MOSFET with gate threshold voltage, $V_{(GSth)}$, rating less than the calculated $V_{(GS)}$.

Now choose a P-channel MOSFET transistor that is rated for $V_{DS} \leq -15\text{ V}$, $\theta_{JC} \leq 110^\circ\text{C/W}$, $I_D \geq 1\text{ A}$, $V_{(GSth)} \geq -3.5\text{ V}$ and in a TSSOP package.

10.1.11 Selecting Input Capacitor

In most applications, all that is needed is a high-frequency decoupling capacitor. A 0.1- μF ceramic, placed in proximity to VCC and VSS pins, works well. The BQ2057 works with both regulated and unregulated external dc supplies. If a nonregulated supply is chosen, the supply unit should have enough capacitance to hold up the supply voltage to the minimum required input voltage at maximum load. If not, more capacitance must be added to the input of the charger.

10.1.12 Selecting Output Capacitor

The BQ2057 does not require any output capacitor for loop stability. The user can add output capacitance in order to control the output voltage when a battery is not present. The charger quickly charges the output capacitor to the regulation voltage, but the output voltage decays slowly, because of the low leakage current on the BAT pin, down to the recharge threshold. Addition of a 0.1- μF ceramic capacitor, for instance, results in a 100-mV(pp) ripple waveform, with an approximate frequency of 25 Hz. Higher capacitor values can be used if a lower frequency is desired.

10.1.13 Automatic Charge-rate Compensation

To reduce charging time, the BQ2057 uses the proprietary AutoComp technique to compensate safely for internal impedance of the battery pack. The AutoComp feature is disabled by connecting the COMP pin to VCC in high-side current-sensing configuration, and to VSS in low-side current-sensing configuration. The COMP pin must not be left floating.

图 10-12 outlines the major components of a single-cell Li-Ion battery pack. The Li-Ion battery pack consists of a cell, protection circuit, fuse, connector, current sense-resistors, and some wiring. Each of these components contains some resistance. Total impedance of the battery pack is the sum of the minimum resistances of all battery-pack components. Using the minimum resistance values reduces the odds for overcompensating. Overcompensating may activate the safety circuit of the battery pack.



图 10-12. Typical Components of a Single-Cell Li-Ion Pack

Compensation is achieved through input pin COMP (图 10-13). A portion of the current-sense voltage, presented through this pin, is scaled by a factor of $G(\text{COMP})$ and summed with the regulation threshold, $V_{O(\text{REG})}$. This process increases the output voltage to compensate for the battery pack's internal impedance and for undesired voltage drops in the circuit.

AutoComp setup requires the following information:

- Total impedance of battery pack ($Z_{(\text{PACK})}$)
- Maximum charging current ($I_{(\text{REG})}$)

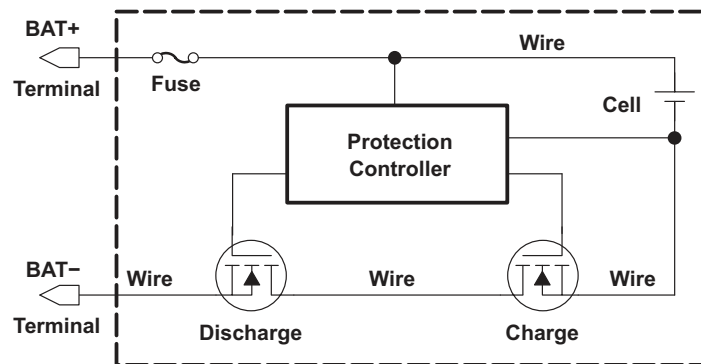
The voltage drop across the internal impedance of battery pack, $V_{(Z)}$, can then be calculated using Equation 13:

$$V_{(Z)} = Z_{(PACK)} \times I_{(REG)} \quad (13)$$

The required compensation is then calculated using [Equation 14](#):

$$V_{(COMP)} = \frac{V_{(Z)}}{G_{(COMP)}}$$

$$V_{(PACK)} = V_{O(REG)} + (G_{(COMP)} \times V_{(COMP)}) \quad (14)$$

Where $V_{(COMP)}$ is the voltage on COMP pin. This voltage is referenced to VCC in high-side current sensing configuration and to VSS for low-side sensing. $V_{(PACK)}$ is the voltage across the battery pack.

The values of $R_{(COMP1)}$ and $R_{(COMP2)}$ can be calculated using [Equation 15](#):

$$\frac{V_{(COMP)}}{V_{(SNS)}} = \frac{R_{COMP2}}{R_{COMP1} + R_{COMP2}} \quad (15)$$



图 10-13. AutoComp Circuits

The following example illustrates these calculations:

Assume $Z_{(PACK)} = 100 \text{ m}\Omega$, $I_{(REG)} = 500 \text{ mA}$, high-side current sensing BQ2057C

$$V_{(Z)} = Z_{(PACK)} \times I_{(REG)}$$

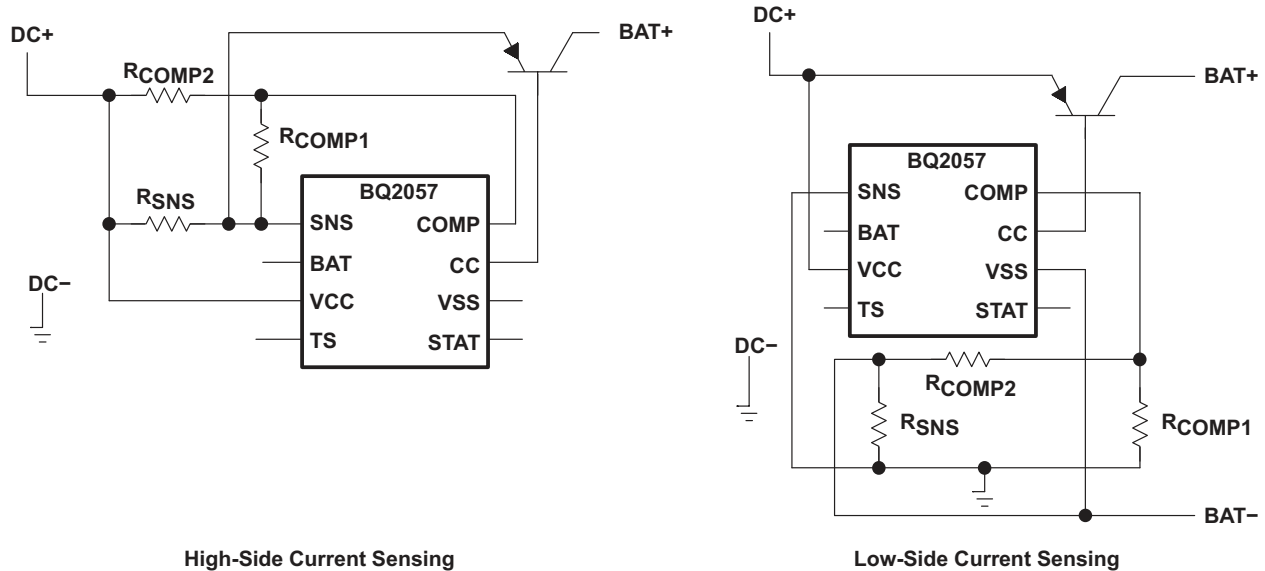
$$V_{(Z)} = 0.1 \times 0.5$$

$$V_{(Z)} = 50 \text{ mV} \quad (16)$$

$$V_{(COMP)} = \frac{V_{(Z)}}{G_{(COMP)}}$$

$$V_{(COMP)} = \frac{0.05}{2.2}$$

$$V_{(COMP)} = 22.7 \text{ mV}$$

Let $R_{COMP2} = 10 \text{ k}\Omega$ (17)

$$R_{COMP1} = \frac{R_{COMP2} \times (V_{(SNS)} - V_{(COMP)})}{V_{(COMP)}}$$

$$R_{COMP1} = 10k \times \frac{(105 \text{ mV} - 22.7 \text{ mV})}{22.7 \text{ mV}}$$

$$R_{COMP1} = 36.25 \text{ k}\Omega$$

(18)

Use the closest standard value (36.0 kΩ) for R_{COMP1}.

10.2 Typical Application



图 10-14. Low Dropout Single- or Two-Cell Li-Ion/Li-Pol Charger

10.2.1 Design Requirements

The design requirements include the following:

- Supply voltage = 12 V
- Dual cell Li-ion 8.2 V
- Fast charge current = 600 mA
 - High-side current sense
- Termination current = 10% (default)
- Precharge current = 10% (default)
- TS - Battery temperature sense = 10 kΩ (103AT, NTC)
 - 0°C cold and 60°C hot

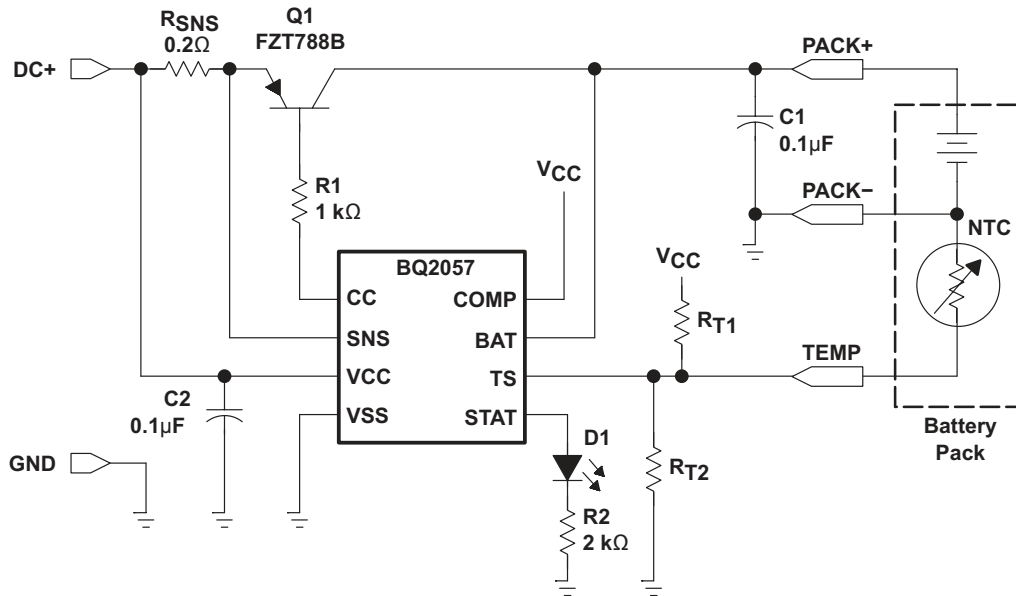
10.2.2 Detailed Design Procedure

The detailed design procedure is listed below:

- Single cell Li-ion, 8.2 V - BQ2057T
- Pass transistor
 - For PNP BJT, see section 10.1.10 PNP transistor
 - For P-Type MOSFET, see section 10.1.10 P-channel MOSFET
- Fast charge current, see equation 1
 - $R_{sns} = V_{sns} / I_{out} = 125 \text{ mV} / 600 \text{ mA} = 0.2 \Omega$

- Termination Current default to 10% of fast charge current
- Pre-Charge Current default to 10% of fast charge current.
- TS - apply Equations 3 and 4 to calculate RT1 and RT2
 - RT1 = 5600 Ω (5.62 kΩ), RT2 = 12326 Ω (12.4 kΩ)

10.2.3 Application Curves



图 10-15. Charge Profile with Battery Simulator



图 10-16. Charge Profile with Battery Simulator - STAT

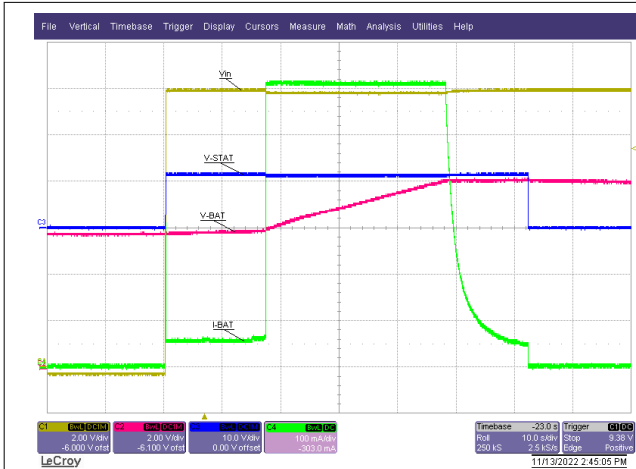

图 10-17. Power On - No Battery

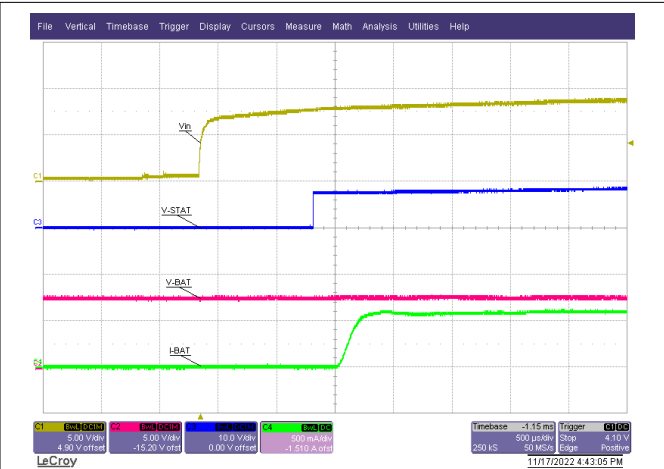

图 10-18. Shutdown - TS Pin Low

11 Power Supply Recommendations

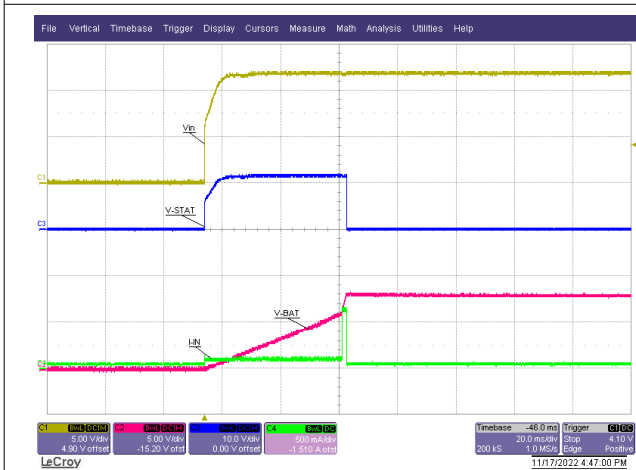
The devices are designed to operate from an input voltage supply range between 4.5 V and 15 V and current capability of at least the maximum designed charge current. This input supply should be well regulated. If located more than a few inches from the device, VCC and GND terminals, a larger capacitor is recommended.

12 Layout

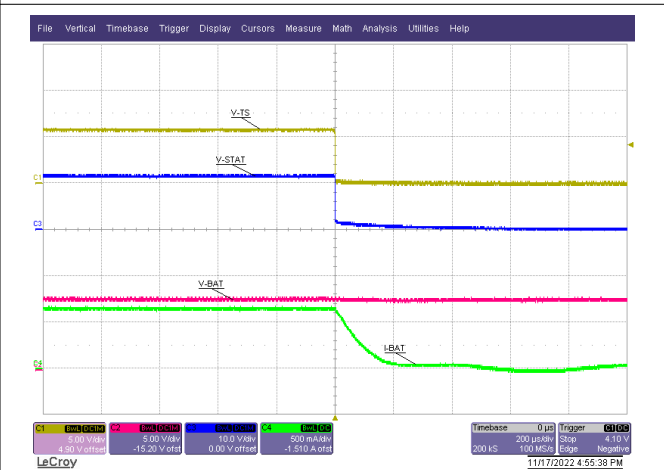
12.1 Layout Guidelines

12.1.1 Power FET

The external pass PNP transistor or P-channel MOSFET will have high thermal rise, good heat sinking will be required.

12.1.2 Current Sense

The BQ2057 regulates current by sensing, on the SNS pin, the voltage drop developed across an external sense resistor. The sense resistor must be placed between the supply voltage (V_{CC}) and the input of the IC (IN pins).

12.1.3 Voltage Sense

To achieve maximum voltage regulation accuracy, the BQ2057 uses the feedback on the BAT pin. Externally, this pin should be connected as close to the battery cell terminals as possible. For additional safety, a 10-k Ω internal pullup resistor is connected between the VSENSE and OUT pins.

12.1.4 Enable (TS)

The TS pin can be used as charge-inhibit. Pulling up to V_{CC} or pulling down to V_{SS} places the device in a low-power standby mode.

12.2 Layout Example



图 12-1. Layout Example



图 12-2. Layout Example

13 Device and Documentation Support

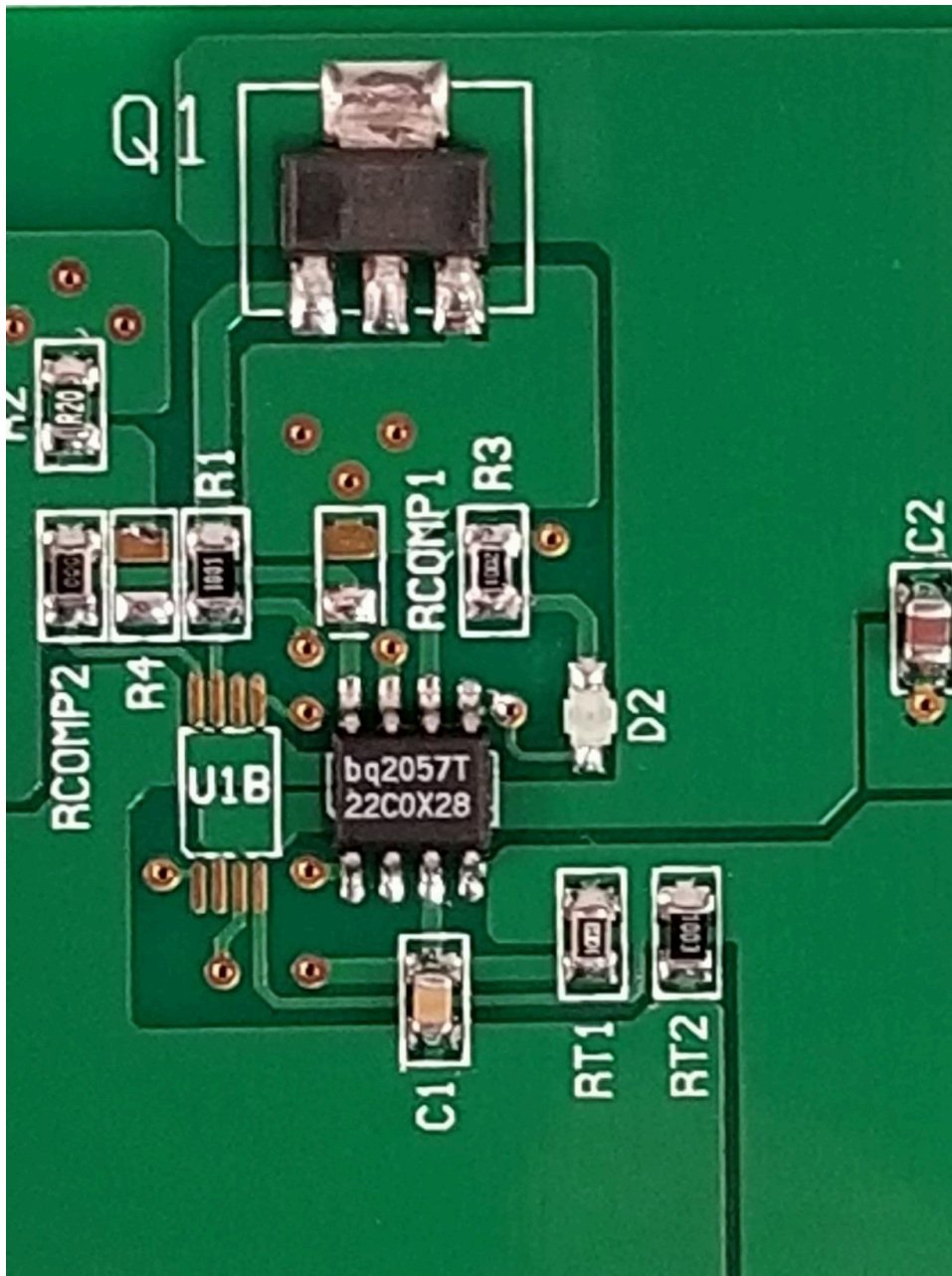
13.1 Device Support

13.1.1 第三方产品免责声明

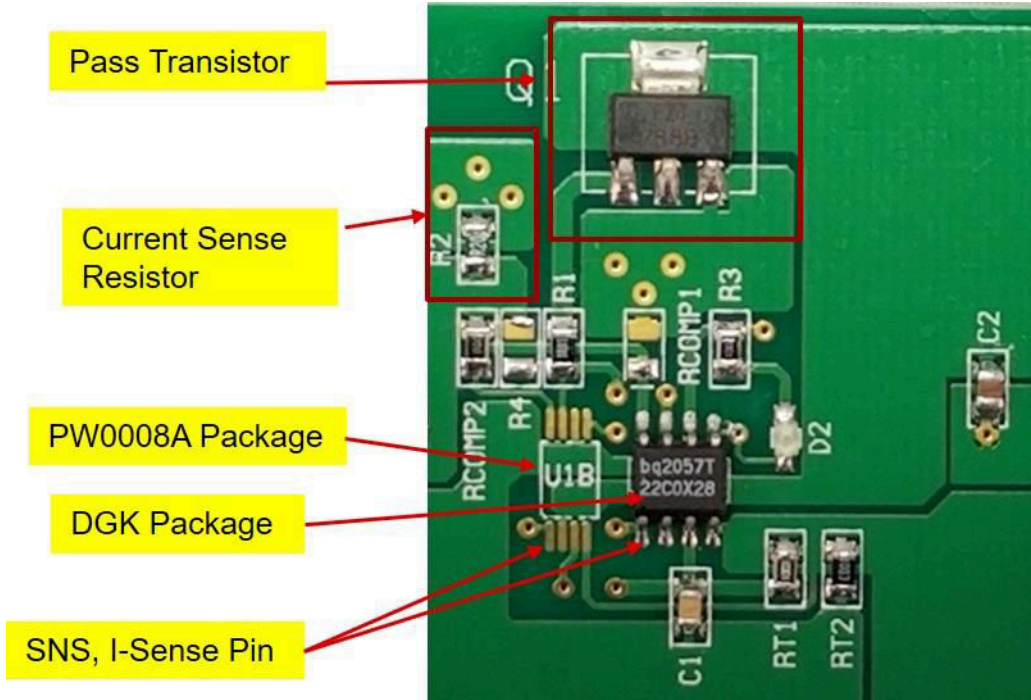
TI 发布的与第三方产品或服务有关的信息，不能构成与此类产品或服务或保修的适用性有关的认可，不能构成此类产品或服务单独或与任何 TI 产品或服务一起的表示或认可。

13.2 接收文档更新通知

要接收文档更新通知，请导航至 ti.com 上的器件产品文件夹。点击 [订阅更新](#) 进行注册，即可每周接收产品信息更改摘要。有关更改的详细信息，请查看任何已修订文档中包含的修订历史记录。

13.3 支持资源

[TI E2E™ 支持论坛](#) 是工程师的重要参考资料，可直接从专家获得快速、经过验证的解答和设计帮助。搜索现有解答或提出自己的问题可获得所需的快速设计帮助。

链接的内容由各个贡献者“按原样”提供。这些内容并不构成 TI 技术规范，并且不一定反映 TI 的观点；请参阅 TI 的《[使用条款](#)》。

13.4 Trademarks

AutoComp™ and TI E2E™ are trademarks of Texas Instruments.

所有商标均为其各自所有者的财产。

13.5 Electrostatic Discharge Caution



This integrated circuit can be damaged by ESD. Texas Instruments recommends that all integrated circuits be handled with appropriate precautions. Failure to observe proper handling and installation procedures can cause damage.

ESD damage can range from subtle performance degradation to complete device failure. Precision integrated circuits may be more susceptible to damage because very small parametric changes could cause the device not to meet its published specifications.

13.6 术语表

[TI 术语表](#) 本术语表列出并解释了术语、首字母缩略词和定义。

14 Mechanical, Packaging, and Orderable Information

The following pages include mechanical, packaging, and orderable information. This information is the most current data available for the designated devices. This data is subject to change without notice and revision of this document. For browser-based versions of this data sheet, refer to the left-hand navigation.

PACKAGING INFORMATION

Orderable Device	Status (1)	Package Type	Package Drawing	Pins	Package Qty	Eco Plan (2)	Lead finish/ Ball material (6)	MSL Peak Temp (3)	Op Temp (°C)	Device Marking (4/5)	Samples
BQ2057CDGK	ACTIVE	VSSOP	DGK	8	80	RoHS & Green	NIPDAUAG	Level-2-260C-1 YEAR	-20 to 70	2057C	Samples
BQ2057CDGKR	ACTIVE	VSSOP	DGK	8	2500	RoHS & Green	Call TI NIPDAUAG	Level-2-260C-1 YEAR	-20 to 70	2057C	Samples
BQ2057CSN	ACTIVE	SOIC	D	8	75	RoHS & Green	NIPDAU	Level-1-260C-UNLIM	-20 to 70	2057C	Samples
BQ2057CSNTR	ACTIVE	SOIC	D	8	2500	RoHS & Green	NIPDAU	Level-1-260C-UNLIM	-20 to 70	2057C	Samples
BQ2057CTS	ACTIVE	TSSOP	PW	8	150	RoHS & Green	NIPDAU	Level-2-260C-1 YEAR	-20 to 70	2057C	Samples
BQ2057CTSTR	ACTIVE	TSSOP	PW	8	2000	RoHS & Green	NIPDAU	Level-2-260C-1 YEAR	-20 to 70	2057C	Samples
BQ2057DGK	ACTIVE	VSSOP	DGK	8	80	RoHS & Green	NIPDAUAG	Level-2-260C-1 YEAR	-20 to 70	2057	Samples
BQ2057SN	ACTIVE	SOIC	D	8	75	RoHS & Green	NIPDAU	Level-1-260C-UNLIM	-20 to 70	2057	Samples
BQ2057SNG4	ACTIVE	SOIC	D	8	75	RoHS & Green	NIPDAU	Level-1-260C-UNLIM	-20 to 70	2057	Samples
BQ2057TS	ACTIVE	TSSOP	PW	8	150	RoHS & Green	NIPDAU	Level-1-260C-UNLIM	-20 to 70	2057	Samples
BQ2057TSN	ACTIVE	SOIC	D	8	75	RoHS & Green	NIPDAU	Level-1-260C-UNLIM	-20 to 70	2057T	Samples
BQ2057TTS	ACTIVE	TSSOP	PW	8	150	RoHS & Green	NIPDAU	Level-2-260C-1 YEAR	-20 to 70	2057T	Samples
BQ2057TTSG4	ACTIVE	TSSOP	PW	8	150	RoHS & Green	NIPDAU	Level-2-260C-1 YEAR	-20 to 70	2057T	Samples
BQ2057TTSTR	ACTIVE	TSSOP	PW	8	2000	RoHS & Green	NIPDAU	Level-2-260C-1 YEAR	-20 to 70	2057T	Samples
BQ2057WSN	ACTIVE	SOIC	D	8	75	RoHS & Green	NIPDAU	Level-1-260C-UNLIM	-20 to 70	2057W	Samples
BQ2057WSNTR	ACTIVE	SOIC	D	8	2500	RoHS & Green	NIPDAU	Level-1-260C-UNLIM	-20 to 70	2057W	Samples
BQ2057WSNTRG4	ACTIVE	SOIC	D	8	2500	RoHS & Green	NIPDAU	Level-1-260C-UNLIM	-20 to 70	2057W	Samples
BQ2057WTS	ACTIVE	TSSOP	PW	8	150	RoHS & Green	NIPDAU	Level-2-260C-1 YEAR	-20 to 70	2057W	Samples
BQ2057WTSG4	ACTIVE	TSSOP	PW	8	150	RoHS & Green	NIPDAU	Level-2-260C-1 YEAR	-20 to 70	2057W	Samples
BQ2057WTSTR	ACTIVE	TSSOP	PW	8	2000	RoHS & Green	NIPDAU	Level-2-260C-1 YEAR	-20 to 70	2057W	Samples

(1) The marketing status values are defined as follows:

ACTIVE: Product device recommended for new designs.

LIFEBUY: TI has announced that the device will be discontinued, and a lifetime-buy period is in effect.

NRND: Not recommended for new designs. Device is in production to support existing customers, but TI does not recommend using this part in a new design.

PREVIEW: Device has been announced but is not in production. Samples may or may not be available.

OBSOLETE: TI has discontinued the production of the device.

(2) **RoHS:** TI defines "RoHS" to mean semiconductor products that are compliant with the current EU RoHS requirements for all 10 RoHS substances, including the requirement that RoHS substance do not exceed 0.1% by weight in homogeneous materials. Where designed to be soldered at high temperatures, "RoHS" products are suitable for use in specified lead-free processes. TI may reference these types of products as "Pb-Free".

RoHS Exempt: TI defines "RoHS Exempt" to mean products that contain lead but are compliant with EU RoHS pursuant to a specific EU RoHS exemption.

Green: TI defines "Green" to mean the content of Chlorine (Cl) and Bromine (Br) based flame retardants meet JS709B low halogen requirements of ≤ 1000 ppm threshold. Antimony trioxide based flame retardants must also meet the ≤ 1000 ppm threshold requirement.

(3) MSL, Peak Temp. - The Moisture Sensitivity Level rating according to the JEDEC industry standard classifications, and peak solder temperature.

(4) There may be additional marking, which relates to the logo, the lot trace code information, or the environmental category on the device.

(5) Multiple Device Markings will be inside parentheses. Only one Device Marking contained in parentheses and separated by a "~" will appear on a device. If a line is indented then it is a continuation of the previous line and the two combined represent the entire Device Marking for that device.

(6) Lead finish/Ball material - Orderable Devices may have multiple material finish options. Finish options are separated by a vertical ruled line. Lead finish/Ball material values may wrap to two lines if the finish value exceeds the maximum column width.

Important Information and Disclaimer: The information provided on this page represents TI's knowledge and belief as of the date that it is provided. TI bases its knowledge and belief on information provided by third parties, and makes no representation or warranty as to the accuracy of such information. Efforts are underway to better integrate information from third parties. TI has taken and continues to take reasonable steps to provide representative and accurate information but may not have conducted destructive testing or chemical analysis on incoming materials and chemicals. TI and TI suppliers consider certain information to be proprietary, and thus CAS numbers and other limited information may not be available for release.

In no event shall TI's liability arising out of such information exceed the total purchase price of the TI part(s) at issue in this document sold by TI to Customer on an annual basis.

TAPE AND REEL INFORMATION

QUADRANT ASSIGNMENTS FOR PIN 1 ORIENTATION IN TAPE

*All dimensions are nominal

Device	Package Type	Package Drawing	Pins	SPQ	Reel Diameter (mm)	Reel Width W1 (mm)	A0 (mm)	B0 (mm)	K0 (mm)	P1 (mm)	W (mm)	Pin1 Quadrant
BQ2057CSNTR	SOIC	D	8	2500	330.0	12.4	6.4	5.2	2.1	8.0	12.0	Q1
BQ2057CTSTR	TSSOP	PW	8	2000	330.0	12.4	7.0	3.6	1.6	8.0	12.0	Q1
BQ2057TTSTR	TSSOP	PW	8	2000	330.0	12.4	7.0	3.6	1.6	8.0	12.0	Q1
BQ2057WTSTR	TSSOP	PW	8	2000	330.0	12.4	7.0	3.6	1.6	8.0	12.0	Q1

TAPE AND REEL BOX DIMENSIONS

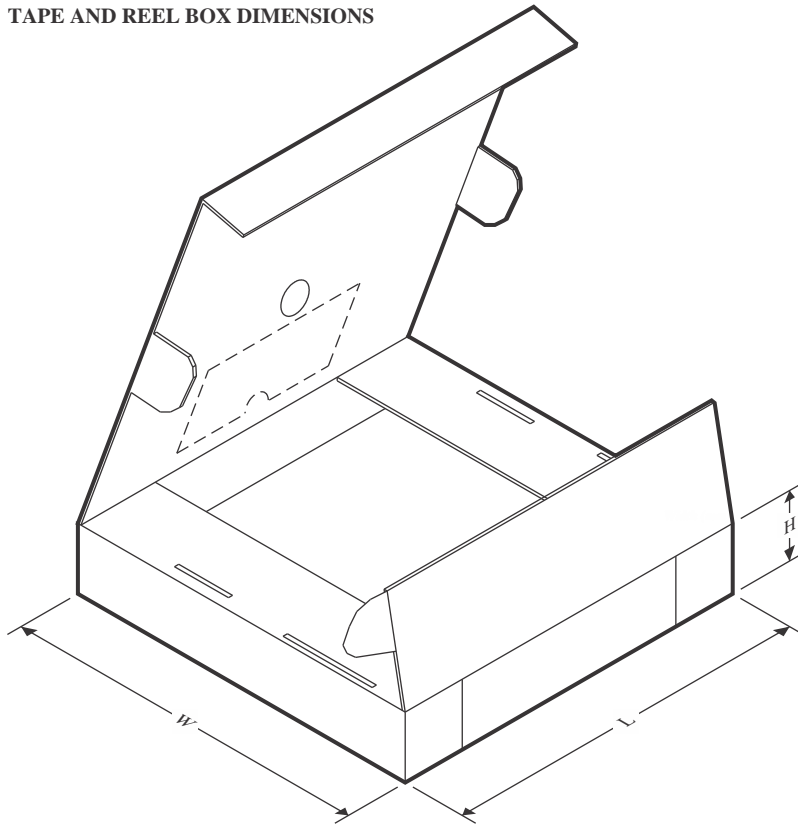

*All dimensions are nominal

Device	Package Type	Package Drawing	Pins	SPQ	Length (mm)	Width (mm)	Height (mm)
BQ2057CSNTR	SOIC	D	8	2500	367.0	367.0	35.0
BQ2057CTSTR	TSSOP	PW	8	2000	367.0	367.0	35.0
BQ2057TTSTR	TSSOP	PW	8	2000	367.0	367.0	35.0
BQ2057WTSTR	TSSOP	PW	8	2000	367.0	367.0	35.0

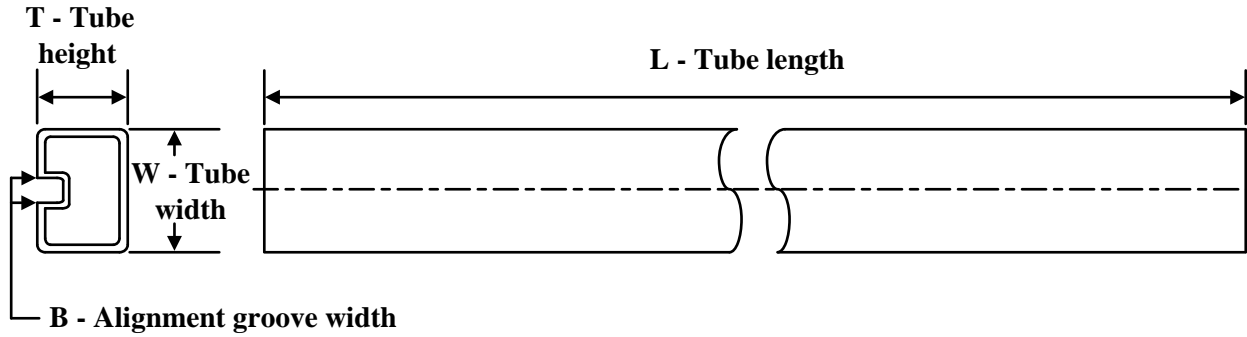
TUBE

*All dimensions are nominal

Device	Package Name	Package Type	Pins	SPQ	L (mm)	W (mm)	T (μm)	B (mm)
BQ2057CDGK	DGK	VSSOP	8	80	330.2	6.6	3005	1.88
BQ2057CSN	D	SOIC	8	75	506.6	8	3940	4.32
BQ2057CTS	PW	TSSOP	8	150	508	8.5	3250	2.8
BQ2057DGK	DGK	VSSOP	8	80	330.2	6.6	3005	1.88
BQ2057SN	D	SOIC	8	75	506.6	8	3940	4.32
BQ2057SNG4	D	SOIC	8	75	506.6	8	3940	4.32
BQ2057TS	PW	TSSOP	8	150	508	8.5	3250	2.8
BQ2057TSN	D	SOIC	8	75	506.6	8	3940	4.32
BQ2057TTS	PW	TSSOP	8	150	508	8.5	3250	2.8
BQ2057TTSG4	PW	TSSOP	8	150	508	8.5	3250	2.8
BQ2057WSN	D	SOIC	8	75	506.6	8	3940	4.32
BQ2057WTS	PW	TSSOP	8	150	508	8.5	3250	2.8
BQ2057WTSG4	PW	TSSOP	8	150	508	8.5	3250	2.8



D0008A

PACKAGE OUTLINE

SOIC - 1.75 mm max height

SMALL OUTLINE INTEGRATED CIRCUIT



4214825/C 02/2019

NOTES:

- Linear dimensions are in inches [millimeters]. Dimensions in parenthesis are for reference only. Controlling dimensions are in inches. Dimensioning and tolerancing per ASME Y14.5M.
- This drawing is subject to change without notice.
- This dimension does not include mold flash, protrusions, or gate burrs. Mold flash, protrusions, or gate burrs shall not exceed .006 [0.15] per side.
- This dimension does not include interlead flash.
- Reference JEDEC registration MS-012, variation AA.

EXAMPLE BOARD LAYOUT

D0008A

SOIC - 1.75 mm max height

SMALL OUTLINE INTEGRATED CIRCUIT



LAND PATTERN EXAMPLE
 EXPOSED METAL SHOWN
 SCALE:8X



SOLDER MASK DETAILS

4214825/C 02/2019

NOTES: (continued)

- 6. Publication IPC-7351 may have alternate designs.
- 7. Solder mask tolerances between and around signal pads can vary based on board fabrication site.

EXAMPLE STENCIL DESIGN

D0008A

SOIC - 1.75 mm max height

SMALL OUTLINE INTEGRATED CIRCUIT



SOLDER PASTE EXAMPLE
BASED ON .005 INCH [0.125 MM] THICK STENCIL
SCALE:8X

4214825/C 02/2019

NOTES: (continued)

8. Laser cutting apertures with trapezoidal walls and rounded corners may offer better paste release. IPC-7525 may have alternate design recommendations.
9. Board assembly site may have different recommendations for stencil design.



- NOTES:
- A. All linear dimensions are in millimeters.
 - B. This drawing is subject to change without notice.
 - C. Publication IPC-7351 is recommended for alternate designs.
 - D. Laser cutting apertures with trapezoidal walls and also rounding corners will offer better paste release. Customers should contact their board assembly site for stencil design recommendations. Refer to IPC-7525 for other stencil recommendations.
 - E. Customers should contact their board fabrication site for solder mask tolerances between and around signal pads.

PW0008A



PACKAGE OUTLINE
TSSOP - 1.2 mm max height

SMALL OUTLINE PACKAGE



4221848/A 02/2015

NOTES:

- All linear dimensions are in millimeters. Any dimensions in parenthesis are for reference only. Dimensioning and tolerancing per ASME Y14.5M.
- This drawing is subject to change without notice.
- This dimension does not include mold flash, protrusions, or gate burrs. Mold flash, protrusions, or gate burrs shall not exceed 0.15 mm per side.
- This dimension does not include interlead flash. Interlead flash shall not exceed 0.25 mm per side.
- Reference JEDEC registration MO-153, variation AA.

EXAMPLE BOARD LAYOUT

PW0008A

TSSOP - 1.2 mm max height

SMALL OUTLINE PACKAGE



LAND PATTERN EXAMPLE
SCALE:10X



SOLDER MASK DETAILS
NOT TO SCALE

4221848/A 02/2015

NOTES: (continued)

- 6. Publication IPC-7351 may have alternate designs.
- 7. Solder mask tolerances between and around signal pads can vary based on board fabrication site.

EXAMPLE STENCIL DESIGN

PW0008A

TSSOP - 1.2 mm max height

SMALL OUTLINE PACKAGE



SOLDER PASTE EXAMPLE
BASED ON 0.125 mm THICK STENCIL
SCALE:10X

4221848/A 02/2015

NOTES: (continued)

8. Laser cutting apertures with trapezoidal walls and rounded corners may offer better paste release. IPC-7525 may have alternate design recommendations.
9. Board assembly site may have different recommendations for stencil design.

重要声明和免责声明

TI“按原样”提供技术和可靠性数据（包括数据表）、设计资源（包括参考设计）、应用或其他设计建议、网络工具、安全信息和其他资源，不保证没有瑕疵且不做任何明示或暗示的担保，包括但不限于对适销性、某特定用途方面的适用性或不侵犯任何第三方知识产权的暗示担保。

这些资源可供使用 TI 产品进行设计的熟练开发人员使用。您将自行承担以下全部责任：(1) 针对您的应用选择合适的 TI 产品，(2) 设计、验证并测试您的应用，(3) 确保您的应用满足相应标准以及任何其他功能安全、信息安全、监管或其他要求。

这些资源如有变更，恕不另行通知。TI 授权您仅可将这些资源用于研发本资源所述的 TI 产品的应用。严禁对这些资源进行其他复制或展示。您无权使用任何其他 TI 知识产权或任何第三方知识产权。您应全额赔偿因在这些资源的使用中对 TI 及其代表造成的任何索赔、损害、成本、损失和债务，TI 对此概不负责。

TI 提供的产品受 [TI 的销售条款](#) 或 [ti.com](#) 上其他适用条款/TI 产品随附的其他适用条款的约束。TI 提供这些资源并不会扩展或以其他方式更改 TI 针对 TI 产品发布的适用的担保或担保免责声明。

TI 反对并拒绝您可能提出的任何其他或不同的条款。

邮寄地址：Texas Instruments, Post Office Box 655303, Dallas, Texas 75265

Copyright © 2023，德州仪器 (TI) 公司

X-ON Electronics

Largest Supplier of Electrical and Electronic Components

Click to view similar products for [Battery Management](#) category:

Click to view products by [Texas Instruments](#) manufacturer:

Other Similar products are found below :

[NCP1851BFCCT1G](#) [NCP1855FCCT1G](#) [FAN54063UCX](#) [MP2615GQ-P](#) [LC05132C01NMTTGTG](#) [ISL95522HRZ](#) [BD8665GW-E2](#)
[ISL9538HRTZ](#) [ISL95522AIRZ](#) [S-82D1AAE-A8T2U7](#) [S-82D1AAA-A8T2U7](#) [S-8224ABA-I8T1U](#) [MP2615CGQ-P](#) [ISL6251HRZ](#)
[ISL6253HRZ](#) [ISL6292-2CR3](#) [ISL6292BCRZ-T](#) [ISL6299AIRZ](#) [ISL9211AIRU58XZ-T](#) [ISL9214IRZ](#) [ISL9220IRTZ-T](#) [FAN54161UCX](#)
[SY6982CQDC](#) [IP6566_AC_30W_ZM](#) [WS3221C-6/TR](#) [ADBMS1818ASWAZ-RL](#) [ADBMS6815WCSWZ](#) [ML5245-005AMBZ07CX](#)
[BQ25672RQMR](#) [ADBMS1818ASWZ-R7](#) [KA49503A-BB](#) [SC33771CTA1MAE](#) [BQ24060DRCR](#) [BQ7695202PFBR](#) [BQ771809DPJR](#)
[BQ24179YBGR](#) [BQ7693002DBTR](#) [BQ25170DSGR](#) [TP4586](#) [FM2119L](#) [FM1623A](#) [DW01](#) [BQ25172DSGR](#) [DW01S](#) [TP4054](#) [MP2723GQC-](#)
[0000-Z](#) [MP26124GR-Z](#) [MP2664GG-0000-Z](#) [MP26029GTF-0000-Z](#) [MP2695GQ-0000-Z](#)