

# CY54FCT540T, CY74FCT540T 8-BIT BUFFERS/LINE DRIVERS WITH 3-STATE OUTPUTS

SCCS029A – MAY 1994 – REVISED OCTOBER 2001

- Function, Pinout, and Drive Compatible With FCT and F Logic
- Reduced  $V_{OH}$  (Typically = 3.3 V) Versions of Equivalent FCT Functions
- Edge-Rate Control Circuitry for Significantly Improved Noise Characteristics
- $I_{off}$  Supports Partial-Power-Down Mode Operation
- ESD Protection Exceeds JESD 22
  - 2000-V Human-Body Model (A114-A)
  - 200-V Machine Model (A115-A)
  - 1000-V Charged-Device Model (C101)
- Matched Rise and Fall Times
- Fully Compatible With TTL Input and Output Logic Levels
- CY54FCT540T
  - 48-mA Output Sink Current
  - 12-mA Output Source Current
- CY74FCT540T
  - 64-mA Output Sink Current
  - 32-mA Output Source Current
- 3-State Outputs

## description

The 'FCT540T inverting buffers/line drivers can be employed as memory address drivers, clock drivers, and bus-oriented transmitters/receivers. These devices provide speed and drive capabilities equivalent to their fastest bipolar-logic counterparts, while reducing power dissipation. The input and output voltage levels allow direct interface with TTL, NMOS, and CMOS devices without external components.

These devices are fully specified for partial-power-down applications using  $I_{off}$ . The  $I_{off}$  circuitry disables the outputs, preventing damaging current backflow through the device when it is powered down.

CY54FCT540T . . . D PACKAGE  
CY74FCT540T . . . Q PACKAGE  
(TOP VIEW)

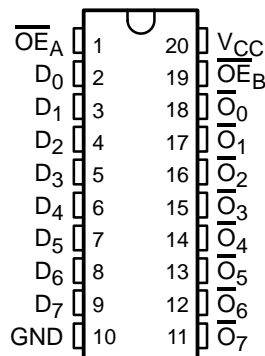

CY54FCT540T . . . L PACKAGE  
(TOP VIEW)

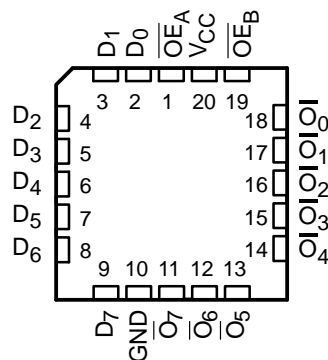

## ORDERING INFORMATION

T <sub>A</sub>	PACKAGE†		SPEED (ns)	ORDERABLE PART NUMBER	TOP-SIDE MARKING
–40°C to 85°C	QSOP – Q	Tape and reel	4.1	CY74FCT540CTQCT	FCT540C
	CDIP – D	Tube	4.7	CY54FCT540CTDMB	
–55°C to 125°C	LCC – L	Tube	4.7	CY54FCT540CTLMB	

† Package drawings, standard packing quantities, thermal data, symbolization, and PCB design guidelines are available at [www.ti.com/sc/package](http://www.ti.com/sc/package).



Please be aware that an important notice concerning availability, standard warranty, and use in critical applications of Texas Instruments semiconductor products and disclaimers thereto appears at the end of this data sheet.

PRODUCTION DATA information is current as of publication date. Products conform to specifications per the terms of Texas Instruments standard warranty. Production processing does not necessarily include testing of all parameters.

 **TEXAS  
INSTRUMENTS**

POST OFFICE BOX 655303 • DALLAS, TEXAS 75265

Copyright © 2001, Texas Instruments Incorporated  
On products compliant to MIL-PRF-38535, all parameters are tested unless otherwise noted. On all other products, production processing does not necessarily include testing of all parameters.

# CY54FCT540T, CY74FCT540T 8-BIT BUFFERS/LINE DRIVERS WITH 3-STATE OUTPUTS

SCCS029A – MAY 1994 – REVISED OCTOBER 2001

FUNCTION TABLE

INPUTS			OUTPUT
$\overline{OE}_A$	$\overline{OE}_B$	D	$\overline{O}$
L	L	L	H
L	L	H	L
H	H	X	Z

H = High logic level, L = Low logic level,  
X = Don't care, Z = High-impedance state

## logic diagram (positive logic)

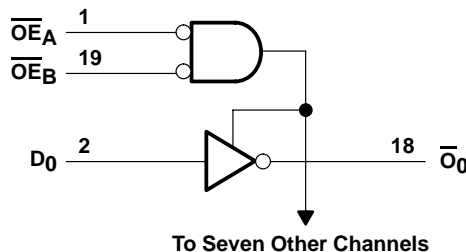

## absolute maximum rating over operating free-air temperature range (unless otherwise noted)†

Supply voltage range to ground potential	-0.5 V to 7 V
DC input voltage range	-0.5 V to 7 V
DC output voltage range	-0.5 V to 7 V
DC output current (maximum sink current/pin)	120 mA
Package thermal impedance, $\theta_{JA}$ (see Note 1): Q package	68°C/W
Ambient temperature range with power applied, $T_A$	-65°C to 135°C
Storage temperature range, $T_{stg}$	-65°C to 150°C

† Stresses beyond those listed under “absolute maximum ratings” may cause permanent damage to the device. These are stress ratings only, and functional operation of the device at these or any other conditions beyond those indicated under “recommended operating conditions” is not implied. Exposure to absolute-maximum-rated conditions for extended periods may affect device reliability.

NOTE 1: The package thermal impedance is calculated in accordance with JESD 51-7.

## recommended operating conditions (see Note 2)

	CY54FCT540T			CY74FCT540T			UNIT
	MIN	NOM	MAX	MIN	NOM	MAX	
$V_{CC}$ Supply voltage	4.5	5	5.5	4.75	5	5.25	V
$V_{IH}$ High-level input voltage	2			2			V
$V_{IL}$ Low-level input voltage			0.8			0.8	V
$I_{OH}$ High-level output current			-12			-32	mA
$I_{OL}$ Low-level output current			48			64	mA
$T_A$ Operating free-air temperature	-55		125	-40		85	°C

NOTE 2: All unused inputs of the device must be held at  $V_{CC}$  or GND to ensure proper device operation.



POST OFFICE BOX 655303 • DALLAS, TEXAS 75265

**CY54FCT540T, CY74FCT540T**  
**8-BIT BUFFERS/LINE DRIVERS**  
**WITH 3-STATE OUTPUTS**

SCCS029A – MAY 1994 – REVISED OCTOBER 2001

**electrical characteristics over recommended operating free-air temperature range (unless otherwise noted)**

PARAMETER	TEST CONDITIONS	CY54FCT540T			CY74FCT540T			UNIT
		MIN	TYP†	MAX	MIN	TYP†	MAX	
V <sub>IK</sub>	V <sub>CC</sub> = 4.5 V, I <sub>IN</sub> = -18 mA		-0.7	-1.2				V
	V <sub>CC</sub> = 4.75 V, I <sub>IN</sub> = -18 mA				-0.7	-1.2		
V <sub>OH</sub>	V <sub>CC</sub> = 4.5 V, I <sub>OH</sub> = -12 mA	2.4	3.3					V
	V <sub>CC</sub> = 4.75 V	I <sub>OH</sub> = -32 mA			2			
		I <sub>OH</sub> = -15 mA			2.4	3.3		
V <sub>OL</sub>	V <sub>CC</sub> = 4.5 V, I <sub>OL</sub> = 48 mA	0.3	0.55					V
	V <sub>CC</sub> = 4.75 V, I <sub>OL</sub> = 64 mA				0.3	0.55		
V <sub>hys</sub>	All inputs		0.2			0.2		V
I <sub>I</sub>	V <sub>CC</sub> = 5.5 V, V <sub>IN</sub> = V <sub>CC</sub>			5				μA
	V <sub>CC</sub> = 5.25 V, V <sub>IN</sub> = V <sub>CC</sub>					5		
I <sub>IH</sub>	V <sub>CC</sub> = 5.5 V, V <sub>IN</sub> = 2.7 V			±1				μA
	V <sub>CC</sub> = 5.25 V, V <sub>IN</sub> = 2.7 V					±1		
I <sub>IL</sub>	V <sub>CC</sub> = 5.5 V, V <sub>IN</sub> = 0.5 V			±1				μA
	V <sub>CC</sub> = 5.25 V, V <sub>IN</sub> = 0.5 V					±1		
I <sub>OZH</sub>	V <sub>CC</sub> = 5.5 V, V <sub>OUT</sub> = 2.7 V			10				μA
	V <sub>CC</sub> = 5.25 V, V <sub>OUT</sub> = 2.7 V					10		
I <sub>OZL</sub>	V <sub>CC</sub> = 5.5 V, V <sub>OUT</sub> = 0.5 V			-10				μA
	V <sub>CC</sub> = 5.25 V, V <sub>OUT</sub> = 0.5 V					-10		
I <sub>OS</sub> ‡	V <sub>CC</sub> = 5.5 V, V <sub>OUT</sub> = 0 V	-60	-120	-225				mA
	V <sub>CC</sub> = 5.25 V, V <sub>OUT</sub> = 0 V				-60	-120	-225	
I <sub>off</sub>	V <sub>CC</sub> = 0 V, V <sub>OUT</sub> = 4.5 V			±1			±1	μA
I <sub>CC</sub>	V <sub>CC</sub> = 5.5 V, V <sub>IN</sub> ≤ 0.2 V, V <sub>IN</sub> ≥ V <sub>CC</sub> - 0.2 V		0.1	0.2				mA
	V <sub>CC</sub> = 5.25 V, V <sub>IN</sub> ≤ 0.2 V, V <sub>IN</sub> ≥ V <sub>CC</sub> - 0.2 V				0.1	0.2		
ΔI <sub>CC</sub>	V <sub>CC</sub> = 5.5 V, V <sub>IN</sub> = 3.4 V§, f <sub>1</sub> = 0, Outputs open		0.5	2				mA
	V <sub>CC</sub> = 5.25 V, V <sub>IN</sub> = 3.4 V§, f <sub>1</sub> = 0, Outputs open				0.5	2		
I <sub>CCD</sub> ¶	V <sub>CC</sub> = 5.5 V, 50% duty cycle, Outputs open, One bit switching at f <sub>1</sub> = 10 MHz, $\overline{OE}_A = \overline{OE}_B = \text{GND}$ or $\overline{OE}_A = \text{GND}$ and $\overline{OE}_B = V_{CC}$ , V <sub>IN</sub> ≤ 0.2 V or V <sub>IN</sub> ≥ V <sub>CC</sub> - 0.2 V		0.06	0.12				mA/ MHz
	V <sub>CC</sub> = 5.25 V, 50% duty cycle, Outputs open, One bit switching at f <sub>1</sub> = 10 MHz, $\overline{OE}_A = \overline{OE}_B = \text{GND}$ or $\overline{OE}_A = \text{GND}$ and $\overline{OE}_B = V_{CC}$ , V <sub>IN</sub> ≤ 0.2 V or V <sub>IN</sub> ≥ V <sub>CC</sub> - 0.2 V					0.06	0.12	

† Typical values are at V<sub>CC</sub> = 5 V, T<sub>A</sub> = 25°C.

‡ Not more than one output should be shorted at a time. Duration of short should not exceed one second. The use of high-speed test apparatus and/or sample-and-hold techniques are preferable to minimize internal chip heating and more accurately reflect operational values. Otherwise, prolonged shorting of a high output can raise the chip temperature well above normal and cause invalid readings in other parametric tests. In any sequence of parameter tests, I<sub>OS</sub> tests should be performed last.

§ Per TTL-driven input (V<sub>IN</sub> = 3.4 V); all other inputs at V<sub>CC</sub> or GND

¶ This parameter is derived for use in total power-supply calculations.



**CY54FCT540T, CY74FCT540T**  
**8-BIT BUFFERS/LINE DRIVERS**  
**WITH 3-STATE OUTPUTS**

SCCS029A – MAY 1994 – REVISED OCTOBER 2001

**electrical characteristics over recommended operating free-air temperature range (unless otherwise noted) (continued)**

PARAMETER	TEST CONDITIONS		CY54FCT540T		CY74FCT540T		UNIT	
			MIN	TYP†	MAX	MIN		TYP†
I <sub>C</sub> #	V <sub>CC</sub> = 5.5 V, Outputs open, $\overline{OE}_A = \overline{OE}_B =$ GND or $\overline{OE}_A =$ GND and $\overline{OE}_B = V_{CC}$	One bit switching at f <sub>1</sub> = 10 MHz at 50% duty cycle	V <sub>IN</sub> ≤ 0.2 V or V <sub>IN</sub> ≥ V <sub>CC</sub> – 0.2 V	0.7	1.4		mA	
			V <sub>IN</sub> = 3.4 V or GND	1	2.4			
		Eight bits switching at f <sub>1</sub> = 2.5 MHz at 50% duty cycle	V <sub>IN</sub> ≤ 0.2 V or V <sub>IN</sub> ≥ V <sub>CC</sub> – 0.2 V	1.3	2.6			
			V <sub>IN</sub> = 3.4 V or GND	3.3	10.6			
	V <sub>CC</sub> = 5.25 V, Outputs open, $\overline{OE}_A = \overline{OE}_B =$ GND or $\overline{OE}_A =$ GND and $\overline{OE}_B = V_{CC}$	One bit switching at f <sub>1</sub> = 10 MHz at 50% duty cycle	V <sub>IN</sub> ≤ 0.2 V or V <sub>IN</sub> ≥ V <sub>CC</sub> – 0.2 V			0.7		1.4
			V <sub>IN</sub> = 3.4 V or GND			1		2.4
		Eight bits switching at f <sub>1</sub> = 2.5 MHz at 50% duty cycle	V <sub>IN</sub> ≤ 0.2 V or V <sub>IN</sub> ≥ V <sub>CC</sub> – 0.2 V			1.3		2.6
			V <sub>IN</sub> = 3.4 V or GND			3.3		10.6
C <sub>i</sub>					5	10	pF	
C <sub>o</sub>					9	12	pF	

† Typical values are at V<sub>CC</sub> = 5 V, T<sub>A</sub> = 25°C.

# I<sub>C</sub> = I<sub>CC</sub> + ΔI<sub>CC</sub> × D<sub>H</sub> × N<sub>T</sub> + I<sub>CCD</sub> (f<sub>0</sub>/2 + f<sub>1</sub> × N<sub>1</sub>)

Where:

- I<sub>C</sub> = Total supply current
- I<sub>CC</sub> = Power-supply current with CMOS input levels
- ΔI<sub>CC</sub> = Power-supply current for a TTL high input (V<sub>IN</sub> = 3.4 V)
- D<sub>H</sub> = Duty cycle for TTL inputs high
- N<sub>T</sub> = Number of TTL inputs at D<sub>H</sub>
- I<sub>CCD</sub> = Dynamic current caused by an input transition pair (HLH or LHL)
- f<sub>0</sub> = Clock frequency for registered devices, otherwise zero
- f<sub>1</sub> = Input signal frequency
- N<sub>1</sub> = Number of inputs changing at f<sub>1</sub>

All currents are in milliamperes and all frequencies are in megahertz.

|| Values for these conditions are examples of the I<sub>CC</sub> formula.



**CY54FCT540T, CY74FCT540T**  
**8-BIT BUFFERS/LINE DRIVERS**  
**WITH 3-STATE OUTPUTS**

SCCS029A – MAY 1994 – REVISED OCTOBER 2001

**switching characteristics over operating free-air temperature range (see Figure 1)**

PARAMETER	FROM (INPUT)	TO (OUTPUT)	CY54FCT540CT		UNIT
			MIN	MAX	
t <sub>PLH</sub>	D	$\bar{O}$	1.5	4.7	ns
t <sub>PHL</sub>			1.5	4.7	
t <sub>PZH</sub>	$\bar{OE}$	$\bar{O}$	1.5	6.5	ns
t <sub>PZL</sub>			1.5	6.5	
t <sub>PHZ</sub>	$\bar{OE}$	$\bar{O}$	1.5	5.7	ns
t <sub>PLZ</sub>			1.5	5.7	

**switching characteristics over operating free-air temperature range (see Figure 1)**

PARAMETER	FROM (INPUT)	TO (OUTPUT)	CY74FCT540CT		UNIT
			MIN	MAX	
t <sub>PLH</sub>	D	$\bar{O}$	1.5	4.1	ns
t <sub>PHL</sub>			1.5	4.1	
t <sub>PZH</sub>	$\bar{OE}$	$\bar{O}$	1.5	5.8	ns
t <sub>PZL</sub>			1.5	5.8	
t <sub>PHZ</sub>	$\bar{OE}$	$\bar{O}$	1.5	5.2	ns
t <sub>PLZ</sub>			1.5	5.2	



# CY54FCT540T, CY74FCT540T 8-BIT BUFFERS/LINE DRIVERS WITH 3-STATE OUTPUTS

SCCS029A – MAY 1994 – REVISED OCTOBER 2001

## PARAMETER MEASUREMENT INFORMATION

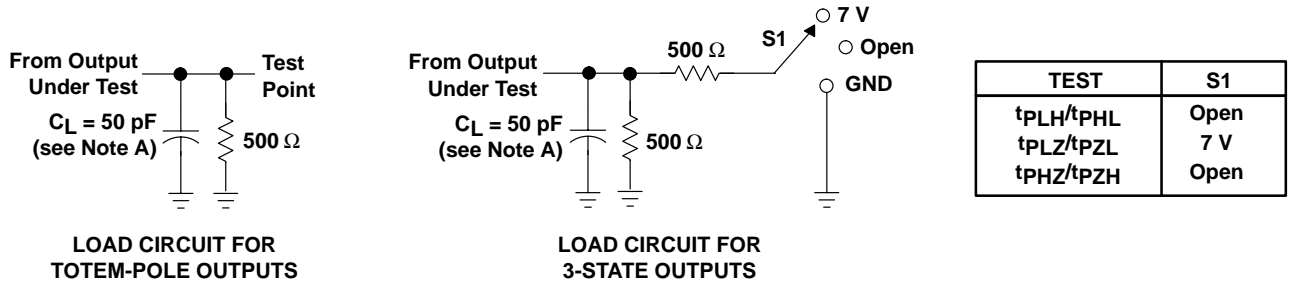

LOAD CIRCUIT FOR  
TOTEM-POLE OUTPUTS

LOAD CIRCUIT FOR  
3-STATE OUTPUTS

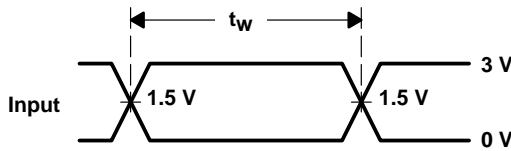

VOLTAGE WAVEFORMS  
PULSE DURATION



VOLTAGE WAVEFORMS  
SETUP AND HOLD TIMES



VOLTAGE WAVEFORMS  
PROPAGATION DELAY TIMES  
INVERTING AND NONINVERTING OUTPUTS



VOLTAGE WAVEFORMS  
ENABLE AND DISABLE TIMES  
LOW- AND HIGH-LEVEL ENABLING

- NOTES: A.  $C_L$  includes probe and jig capacitance.  
 B. Waveform 1 is for an output with internal conditions such that the output is low except when disabled by the output control. Waveform 2 is for an output with internal conditions such that the output is high except when disabled by the output control.  
 C. The outputs are measured one at a time with one input transition per measurement.

Figure 1. Load Circuit and Voltage Waveforms

**PACKAGING INFORMATION**

Orderable Device	Status (1)	Package Type	Package Drawing	Pins	Package Qty	Eco Plan (2)	Lead finish/ Ball material (6)	MSL Peak Temp (3)	Op Temp (°C)	Device Marking (4/5)	Samples
5962-9222006MRA	ACTIVE	CDIP	J	20	1	Non-RoHS & Green	SNPB	N / A for Pkg Type	-55 to 125	5962-9222006MR A	<a href="#">Samples</a>
5962-9223701M2A	ACTIVE	LCCC	FK	20	1	Non-RoHS & Green	SNPB	N / A for Pkg Type	-55 to 125	5962- 9223701M2A CY54FCT 541TLMB	<a href="#">Samples</a>
5962-9223701MRA	ACTIVE	CDIP	J	20	1	Non-RoHS & Green	SNPB	N / A for Pkg Type	-55 to 125	5962-9223701MR A CY54FCT541TDMB	<a href="#">Samples</a>
5962-9223705MRA	ACTIVE	CDIP	J	20	1	Non-RoHS & Green	SNPB	N / A for Pkg Type	-55 to 125	5962-9223705MR A	<a href="#">Samples</a>
CY54FCT541TDMB	ACTIVE	CDIP	J	20	1	Non-RoHS & Green	SNPB	N / A for Pkg Type	-55 to 125	5962-9223701MR A CY54FCT541TDMB	<a href="#">Samples</a>
CY54FCT541TLMB	ACTIVE	LCCC	FK	20	1	Non-RoHS & Green	SNPB	N / A for Pkg Type	-55 to 125	5962- 9223701M2A CY54FCT 541TLMB	<a href="#">Samples</a>
CY74FCT540CTQCT	ACTIVE	SSOP	DBQ	20	2500	RoHS & Green	NIPDAU	Level-2-260C-1 YEAR	-40 to 85	FCT540C	<a href="#">Samples</a>
CY74FCT541ATPC	ACTIVE	PDIP	N	20	20	RoHS & Non-Green	NIPDAU	N / A for Pkg Type	-40 to 85	CY74FCT541ATPC	<a href="#">Samples</a>
CY74FCT541ATQCT	ACTIVE	SSOP	DBQ	20	2500	RoHS & Green	NIPDAU	Level-2-260C-1 YEAR	-40 to 85	FCT541A	<a href="#">Samples</a>
CY74FCT541ATSOC	ACTIVE	SOIC	DW	20	25	RoHS & Green	NIPDAU	Level-1-260C-UNLIM	-40 to 85	FCT541A	<a href="#">Samples</a>
CY74FCT541ATSOCT	ACTIVE	SOIC	DW	20	2000	RoHS & Green	NIPDAU	Level-1-260C-UNLIM	-40 to 85	FCT541A	<a href="#">Samples</a>
CY74FCT541CTQCT	ACTIVE	SSOP	DBQ	20	2500	RoHS & Green	NIPDAU	Level-2-260C-1 YEAR	-40 to 85	FCT541C	<a href="#">Samples</a>
CY74FCT541CTSOC	ACTIVE	SOIC	DW	20	25	RoHS & Green	NIPDAU	Level-1-260C-UNLIM	-40 to 85	FCT541C	<a href="#">Samples</a>
CY74FCT541CTSOCT	ACTIVE	SOIC	DW	20	2000	RoHS & Green	NIPDAU	Level-1-260C-UNLIM	-40 to 85	FCT541C	<a href="#">Samples</a>
CY74FCT541TQCT	ACTIVE	SSOP	DBQ	20	2500	RoHS & Green	NIPDAU	Level-2-260C-1 YEAR	-40 to 85	FCT541	<a href="#">Samples</a>

Orderable Device	Status (1)	Package Type	Package Drawing	Pins	Package Qty	Eco Plan (2)	Lead finish/ Ball material (6)	MSL Peak Temp (3)	Op Temp (°C)	Device Marking (4/5)	Samples
CY74FCT541TSOC	ACTIVE	SOIC	DW	20	25	RoHS & Green	NIPDAU	Level-1-260C-UNLIM	-40 to 85	FCT541	Samples

(1) The marketing status values are defined as follows:

**ACTIVE:** Product device recommended for new designs.

**LIFEBUY:** TI has announced that the device will be discontinued, and a lifetime-buy period is in effect.

**NRND:** Not recommended for new designs. Device is in production to support existing customers, but TI does not recommend using this part in a new design.

**PREVIEW:** Device has been announced but is not in production. Samples may or may not be available.

**OBSELETE:** TI has discontinued the production of the device.

(2) **RoHS:** TI defines "RoHS" to mean semiconductor products that are compliant with the current EU RoHS requirements for all 10 RoHS substances, including the requirement that RoHS substance do not exceed 0.1% by weight in homogeneous materials. Where designed to be soldered at high temperatures, "RoHS" products are suitable for use in specified lead-free processes. TI may reference these types of products as "Pb-Free".

**RoHS Exempt:** TI defines "RoHS Exempt" to mean products that contain lead but are compliant with EU RoHS pursuant to a specific EU RoHS exemption.

**Green:** TI defines "Green" to mean the content of Chlorine (Cl) and Bromine (Br) based flame retardants meet JS709B low halogen requirements of <=1000ppm threshold. Antimony trioxide based flame retardants must also meet the <=1000ppm threshold requirement.

(3) MSL, Peak Temp. - The Moisture Sensitivity Level rating according to the JEDEC industry standard classifications, and peak solder temperature.

(4) There may be additional marking, which relates to the logo, the lot trace code information, or the environmental category on the device.

(5) Multiple Device Markings will be inside parentheses. Only one Device Marking contained in parentheses and separated by a "~" will appear on a device. If a line is indented then it is a continuation of the previous line and the two combined represent the entire Device Marking for that device.

(6) Lead finish/Ball material - Orderable Devices may have multiple material finish options. Finish options are separated by a vertical ruled line. Lead finish/Ball material values may wrap to two lines if the finish value exceeds the maximum column width.

**Important Information and Disclaimer:**The information provided on this page represents TI's knowledge and belief as of the date that it is provided. TI bases its knowledge and belief on information provided by third parties, and makes no representation or warranty as to the accuracy of such information. Efforts are underway to better integrate information from third parties. TI has taken and continues to take reasonable steps to provide representative and accurate information but may not have conducted destructive testing or chemical analysis on incoming materials and chemicals. TI and TI suppliers consider certain information to be proprietary, and thus CAS numbers and other limited information may not be available for release.

In no event shall TI's liability arising out of such information exceed the total purchase price of the TI part(s) at issue in this document sold by TI to Customer on an annual basis.

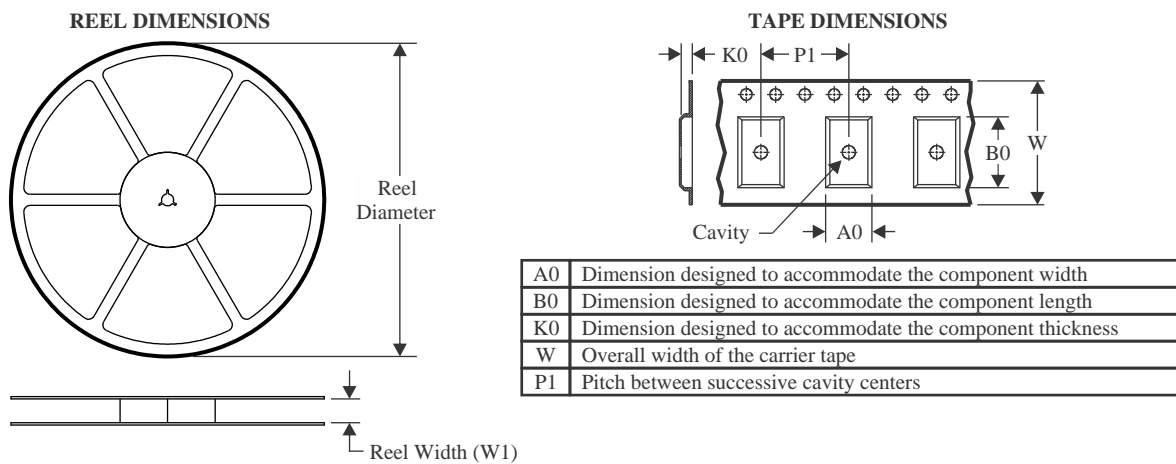

**TAPE AND REEL INFORMATION**

**QUADRANT ASSIGNMENTS FOR PIN 1 ORIENTATION IN TAPE**



\*All dimensions are nominal

Device	Package Type	Package Drawing	Pins	SPQ	Reel Diameter (mm)	Reel Width W1 (mm)	A0 (mm)	B0 (mm)	K0 (mm)	P1 (mm)	W (mm)	Pin1 Quadrant
CY74FCT540CTQCT	SSOP	DBQ	20	2500	330.0	16.4	6.5	9.0	2.1	8.0	16.0	Q1
CY74FCT541ATQCT	SSOP	DBQ	20	2500	330.0	16.4	6.5	9.0	2.1	8.0	16.0	Q1
CY74FCT541ATSOCT	SOIC	DW	20	2000	330.0	24.4	10.8	13.3	2.7	12.0	24.0	Q1
CY74FCT541CTQCT	SSOP	DBQ	20	2500	330.0	16.4	6.5	9.0	2.1	8.0	16.0	Q1
CY74FCT541CTSOCT	SOIC	DW	20	2000	330.0	24.4	10.8	13.3	2.7	12.0	24.0	Q1
CY74FCT541TQCT	SSOP	DBQ	20	2500	330.0	16.4	6.5	9.0	2.1	8.0	16.0	Q1

**TAPE AND REEL BOX DIMENSIONS**

\*All dimensions are nominal

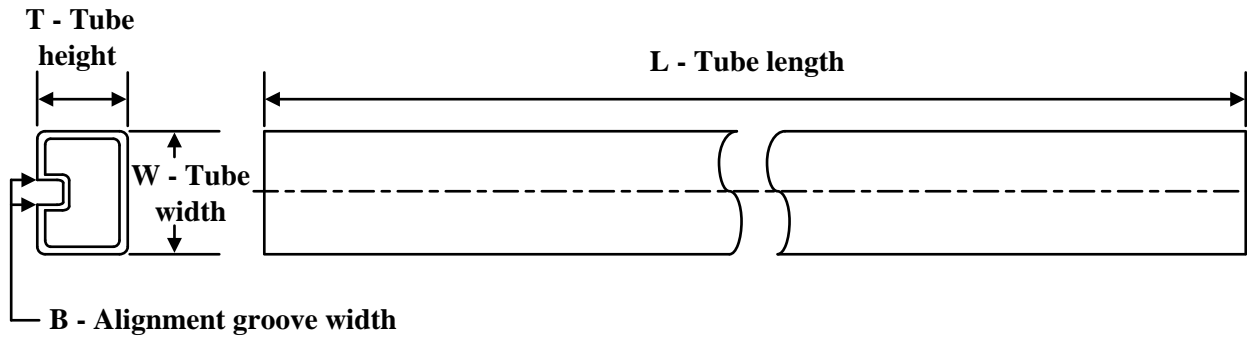
Device	Package Type	Package Drawing	Pins	SPQ	Length (mm)	Width (mm)	Height (mm)
CY74FCT540CTQCT	SSOP	DBQ	20	2500	356.0	356.0	35.0
CY74FCT541ATQCT	SSOP	DBQ	20	2500	356.0	356.0	35.0
CY74FCT541ATSOCT	SOIC	DW	20	2000	367.0	367.0	45.0
CY74FCT541CTQCT	SSOP	DBQ	20	2500	356.0	356.0	35.0
CY74FCT541CTSOCT	SOIC	DW	20	2000	367.0	367.0	45.0
CY74FCT541TQCT	SSOP	DBQ	20	2500	356.0	356.0	35.0

**TUBE**

\*All dimensions are nominal

Device	Package Name	Package Type	Pins	SPQ	L (mm)	W (mm)	T (μm)	B (mm)
5962-9223701M2A	FK	LCCC	20	1	506.98	12.06	2030	NA
CY54FCT541TLMB	FK	LCCC	20	1	506.98	12.06	2030	NA
CY74FCT541ATPC	N	PDIP	20	20	506	13.97	11230	4.32
CY74FCT541ATSOC	DW	SOIC	20	25	507	12.83	5080	6.6
CY74FCT541CTSOC	DW	SOIC	20	25	507	12.83	5080	6.6
CY74FCT541TSOC	DW	SOIC	20	25	507	12.83	5080	6.6

## IMPORTANT NOTICE AND DISCLAIMER

TI PROVIDES TECHNICAL AND RELIABILITY DATA (INCLUDING DATA SHEETS), DESIGN RESOURCES (INCLUDING REFERENCE DESIGNS), APPLICATION OR OTHER DESIGN ADVICE, WEB TOOLS, SAFETY INFORMATION, AND OTHER RESOURCES "AS IS" AND WITH ALL FAULTS, AND DISCLAIMS ALL WARRANTIES, EXPRESS AND IMPLIED, INCLUDING WITHOUT LIMITATION ANY IMPLIED WARRANTIES OF MERCHANTABILITY, FITNESS FOR A PARTICULAR PURPOSE OR NON-INFRINGEMENT OF THIRD PARTY INTELLECTUAL PROPERTY RIGHTS.

These resources are intended for skilled developers designing with TI products. You are solely responsible for (1) selecting the appropriate TI products for your application, (2) designing, validating and testing your application, and (3) ensuring your application meets applicable standards, and any other safety, security, regulatory or other requirements.

These resources are subject to change without notice. TI grants you permission to use these resources only for development of an application that uses the TI products described in the resource. Other reproduction and display of these resources is prohibited. No license is granted to any other TI intellectual property right or to any third party intellectual property right. TI disclaims responsibility for, and you will fully indemnify TI and its representatives against, any claims, damages, costs, losses, and liabilities arising out of your use of these resources.

TI's products are provided subject to [TI's Terms of Sale](#) or other applicable terms available either on [ti.com](http://ti.com) or provided in conjunction with such TI products. TI's provision of these resources does not expand or otherwise alter TI's applicable warranties or warranty disclaimers for TI products.

TI objects to and rejects any additional or different terms you may have proposed.

Mailing Address: Texas Instruments, Post Office Box 655303, Dallas, Texas 75265  
Copyright © 2022, Texas Instruments Incorporated

## X-ON Electronics

Largest Supplier of Electrical and Electronic Components

*Click to view similar products for [Buffers & Line Drivers](#) category:*

*Click to view products by [Texas Instruments](#) manufacturer:*

Other Similar products are found below :

[LXV200-024SW](#) [74AUP2G34FW3-7](#) [HEF4043BP](#) [NL17SG125DFT2G](#) [NLU1GT126CMUTCG](#) [CD4041UBE](#) [54FCT240CTDB](#)  
[74HCT540N](#) [DS14C88N](#) [070519XB](#) [NL17SZ07P5T5G](#) [74LVC2G17FW4-7](#) [CD4502BE](#) [5962-8982101PA](#) [61446R00](#) [NL17SH17P5T5G](#)  
[NLV37WZ17USG](#) [74HCT126T14-13](#) [74VHC9126FT\(BJ\)](#) [RHRXH162244K1](#) [74AUP1G34FW5-7](#) [74AUP1G07FW5-7](#) [74LVC1G126FW4-7](#)  
[74LVC2G126RA3-7](#) [74LVCE1G125FZ4-7](#) [54FCT240TLB](#) [NLX3G16DMUTCG](#) [NLX2G06AMUTCG](#) [LE87100NQCT](#) [LE87285NQC](#)  
[LE87290YQC](#) [LE87290YQCT](#) [74AUP1G125FW5-7](#) [NLU2G16CMUTCG](#) [MC74LCX244MN2TWG](#) [NL17SG17P5T5G](#)  
[NLV74HC125ADR2G](#) [NLVHCT245ADTR2G](#) [NLVVHC1G126DFT2G](#) [EL5623IRZ](#) [ISL15102AIRZ-T13](#) [ISL1539IRZ-T13](#)  
[MC100EP17MNG](#) [MC74HCT365ADR2G](#) [MC74LCX244ADTR2G](#) [NL27WZ126US](#) [NL37WZ16US](#) [NLU1G07MUTCG](#) [NLU2G07MUTCG](#)  
[NLX3G17BMX1TCG](#)