

# DRV8213 4-A Brushed DC Motor Driver with Integrated Current Sense, Current Regulation and Stall Detection

## 1 Features

- N-channel H-bridge brushed DC motor driver
- **1.65-V to 11-V** operating supply voltage range
- **240-mΩ**  $R_{DS(on)}$  (High-Side + Low-Side)
- High output current capability: 4-A Peak
- PWM control interface, up to 100 kHz switching
- Supports 1.8-V, 3.3-V, and 5-V logic inputs
- Integrated current sensing and current regulation
- Analog current sense output (**IPROPI**)
- Gain select (**GAINSEL**) feature for -
  - High accuracy current sensing down to **10 mA**
  - Optimized  $R_{DS(ON)}$  and overcurrent limit for different current ranges
- Configurable inrush time (RTE Package only)
- **Internal** charge pump
- Long battery life with low-power sleep mode
  - **< 60 nA** maximum sleep current
- Small package footprint
- Integrated protection features
  - VM undervoltage lockout (UVLO)
  - Auto-retry overcurrent protection (OCP)
  - Thermal shutdown (TSD)
  - **Stall detection** (RTE Package only)

## 2 Applications

- [Brushed DC motor, solenoid, & relay driving](#)
- [Water and gas meters](#)
- [Electronic smart lock](#)
- [Electronic and robotic toys](#)
- [Infusion pumps and other portable medical equipments](#)
- [Electric toothbrush](#)
- [Beauty & grooming](#)
- Portable printers
- Point-of-sale (POS) devices
- Other battery powered DC motor applications

## 3 Description

The DRV8213 is an integrated motor driver with N-channel H-bridge, charge pump, current sense output, current regulation, and protection circuitry. The tripler charge pump allows the device to operate down to 1.65 V to accommodate 1.8-V supply rails and low-battery conditions. The charge pump integrates all capacitors and allows for 100% duty cycle operation.

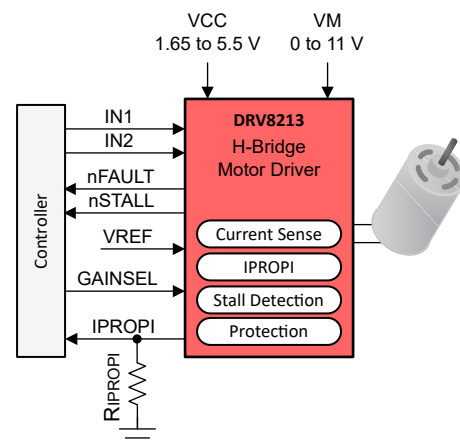
An internal current mirror implements current sensing and regulation. This eliminates the need for a large power shunt resistor, saving board area and reducing system cost. The IPROPI current sense output allows a microcontroller to detect motor stall or changes in load conditions. The gain select (GAINSEL) feature allows high accuracy current sensing down to 10 mA average motor current. Using the VREF pin, this device can regulate the motor current during startup and high-load events without interaction from a microcontroller. The RTE package supports sensorless motor stall detection and reporting to microcontroller.

A low-power sleep mode achieves ultra-low quiescent current by shutting down most of the internal circuitry. Internal protection features include undervoltage lockout, overcurrent, and overtemperature.

### Device Information (1)

PART NUMBER	PACKAGE	BODY SIZE (NOM)
DRV8213DSG	WSON (8)	2.00 mm × 2.00 mm
DRV8213RTE	WQFN (16)	3.00 mm × 3.00 mm

- (1) For all available packages, see the orderable addendum at the end of the data sheet.



**Simplified Schematic (RTE Package)**



## Table of Contents

<b>1 Features</b> .....	<b>1</b>	8.4 Feature Description.....	<b>14</b>
<b>2 Applications</b> .....	<b>1</b>	8.5 Device Functional Modes.....	<b>23</b>
<b>3 Description</b> .....	<b>1</b>	8.6 Pin Diagrams.....	<b>24</b>
<b>4 Revision History</b> .....	<b>2</b>	<b>9 Application and Implementation</b> .....	<b>26</b>
<b>5 Device Comparison</b> .....	<b>3</b>	9.1 Application Information.....	<b>26</b>
<b>6 Pin Configuration and Functions</b> .....	<b>3</b>	9.2 Typical Application.....	<b>26</b>
<b>7 Specifications</b> .....	<b>5</b>	<b>10 Power Supply Recommendations</b> .....	<b>38</b>
7.1 Absolute Maximum Ratings.....	<b>5</b>	10.1 Bulk Capacitance.....	<b>38</b>
7.2 ESD Ratings.....	<b>5</b>	<b>11 Layout</b> .....	<b>39</b>
7.3 Recommended Operating Conditions.....	<b>5</b>	11.1 Layout Guidelines.....	<b>39</b>
7.4 Thermal Information.....	<b>6</b>	<b>12 Device and Documentation Support</b> .....	<b>40</b>
7.5 Electrical Characteristics.....	<b>6</b>	12.1 Documentation Support.....	<b>40</b>
7.6 Timing Diagrams.....	<b>9</b>	12.2 Receiving Notification of Documentation Updates..	<b>40</b>
7.7 Typical Operating Characteristics.....	<b>9</b>	12.3 Community Resources.....	<b>40</b>
<b>8 Detailed Description</b> .....	<b>11</b>	12.4 Trademarks.....	<b>40</b>
8.1 Overview.....	<b>11</b>	<b>13 Mechanical, Packaging, and Orderable Information</b> .....	<b>40</b>
8.2 Functional Block Diagram.....	<b>12</b>	13.1 Tape and Reel Information.....	<b>47</b>
8.3 External Components.....	<b>13</b>		

## 4 Revision History

NOTE: Page numbers for previous revisions may differ from page numbers in the current version.

DATE	REVISION	NOTES
August 2023	*	Initial Release

## 5 Device Comparison

Table 5-1. Device Comparison Table

Part Number	Package	Supply (VM, Volts)	R <sub>DS(on)</sub> (mΩ)	Current Regulation	Current Sense Output	Stall Detection	Package Size
DRV8213	RTE	1.65 to 11	240	Yes	Yes	Yes	3 mm x 3 mm
DRV8213	DSG	1.65 to 11	240	Yes	Yes	No	2 mm x 2 mm
DRV8212/P	DSG	1.65 to 11	280	No	No	No	2 mm x 2 mm
DRV8210/P	DSG	1.65 to 11	1000	No	No	No	2 mm x 2 mm
DRV8837	DSG	0 to 11	280	No	No	No	2 mm x 2 mm
DRV8837C	DSG	0 to 11	1000	No	No	No	2 mm x 2 mm

## 6 Pin Configuration and Functions

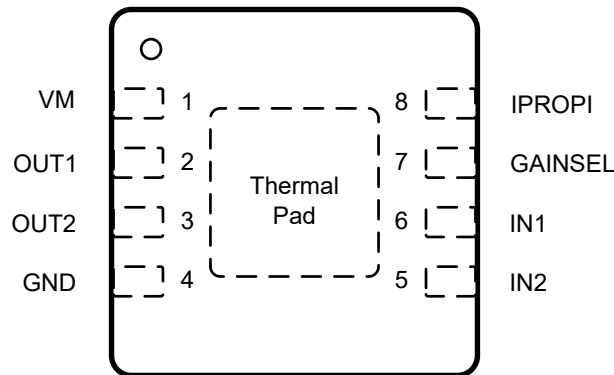


Figure 6-1. DSG Package (WSON) Top View

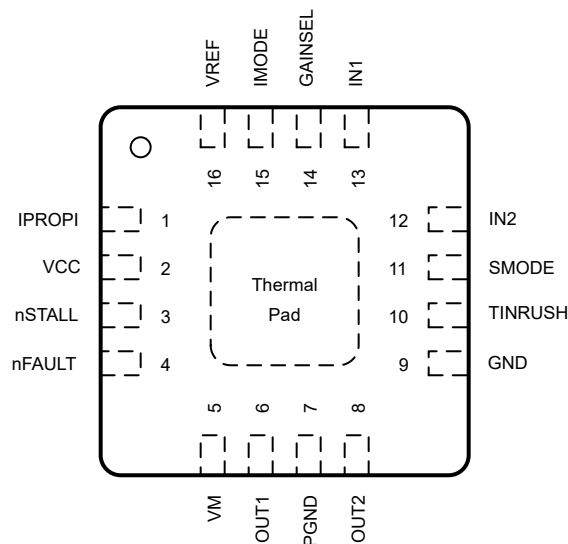


Figure 6-2. RTE Package (WQFN) Top View

Table 6-1. Pin Functions

PIN			TYPE	DESCRIPTION
NAME	DSG	RTE		
GND	4	9	PWR	Device ground. Connect to system ground.

**Table 6-1. Pin Functions (continued)**

PIN			TYPE	DESCRIPTION
NAME	DSG	RTE		
IMODE	—	15	I	Current regulation mode configuration. Tri-level input. See <a href="#">Table 8-4</a> .
IN1	6	13	I	Controls the H-bridge output. Has internal pulldown. Logic input. See <a href="#">Table 8-2</a> .
IN2	5	12	I	Controls the H-bridge output. Has internal pulldown. Logic input. See <a href="#">Table 8-2</a> .
IPROPI	8	1	PWR	Analog current output proportional to load current. See <a href="#">Section 8.4.2.1</a> .
nFAULT	—	4	OD	Fault indicator output. Pulled low during a fault condition. Connect an external pullup resistor for open-drain operation. Connect to nSTALL pin to reduce number of external components. See <a href="#">Section 8.4.4</a> .
nSTALL	—	3	OD	Stall detection enable and stall indicator output. Pulled low during a stall condition. Connect an external pullup resistor for open-drain operation. Connect to nFAULT pin to reduce number of external components. Connect to GND to disable stall detection. See <a href="#">Section 8.4.3</a> .
OUT1	2	6	O	H-bridge output. Connect directly to the motor or other inductive load.
OUT2	3	8	O	H-bridge output. Connect directly to the motor or other inductive load.
PGND	—	7	PWR	Device power ground. Connect to system ground.
SMODE	—	11	I	Stall detection response configuration. Tri-level input. See <a href="#">Table 8-6</a> .
TINRUSH	—	10	O	Sets timing for stall detection to ignore motor inrush current. Connect to a ceramic capacitor to system ground. See <a href="#">Section 8.4.3</a> .
VCC	—	2	PWR	Logic power supply. Bypass this pin to the GND pin with a 0.1- $\mu$ F ceramic capacitor rated for VCC.
VM	1	5	PWR	Motor power supply. Bypass this pin to the GND pin with a 0.1- $\mu$ F ceramic capacitor as well as sufficient bulk capacitance rated for VM.
VREF	—	16	I	Analog input to set current regulation and stall detection level. For the DSG package, VREF is internally fixed at 510 mV. For information on current regulation, see <a href="#">Section 8.4.2.2</a> . For more information on stall detection, see <a href="#">Section 8.4.3</a> .
GAINSEL	7	14	I	Configures IPROPI gain factor depending on the output current range. Tri-level input.
PAD	—	—	—	Thermal pad. Connect to board ground. For good thermal dissipation, use large ground planes on multiple layers, and multiple nearby vias connecting those planes.

## 7 Specifications

### 7.1 Absolute Maximum Ratings

over operating temperature range (unless otherwise noted)<sup>(1)</sup>

		MIN	MAX	UNIT
Power supply pin voltage	VM	-0.5	12	V
Logic power supply pin voltage	VCC	-0.5	5.75	V
Power supply transient voltage ramp	VM, VCC	0	2	V/ $\mu$ s
Voltage difference between ground pins	GND, PGND	-0.6	0.6	V
Logic pin voltage	IN1, IN2, GAINSEL, nSLEEP, IMODE, SMODE	-0.3	5.75	V
Open-drain output pin voltage	nFAULT, nSTALL	-0.3	5.75	V
Timing capacitor current output pin voltage	TINRUSH	-0.3	V <sub>VCC</sub>	V
Proportional current output pin voltage, VM $\geq$ 5.45 V	IPROPI	-0.3	5.75	V
Proportional current output pin voltage, VM < 5.45 V		-0.3	V <sub>VM</sub> + 0.3	V
Reference input pin voltage	VREF	0.3	5.75	V
Output pin voltage	OUTx	-V <sub>SD</sub>	V <sub>VM</sub> +V <sub>SD</sub>	V
Output current	OUTx	Internally Limited	Internally Limited	A
Ambient temperature, T <sub>A</sub>		-40	125	°C
Junction temperature, T <sub>J</sub>		-40	150	°C
Storage temperature, T <sub>stg</sub>		-65	150	°C

- (1) Stresses beyond those listed under *Absolute Maximum Rating* may cause permanent damage to the device. These are stress ratings only, which do not imply functional operation of the device at these or any other conditions beyond those indicated under *Recommended Operating Condition*. Exposure to absolute-maximum-rated conditions for extended periods may affect device reliability.

### 7.2 ESD Ratings

			VALUE	UNIT
V <sub>(ESD)</sub>	Electrostatic discharge	Human body model (HBM), per ANSI/ESDA/JEDEC JS-001 <sup>(1)</sup>	$\pm$ 2000	V
		Charged device model (CDM), per JEDEC specification JESD22-C101 <sup>(2)</sup>	$\pm$ 500	

- (1) JEDEC document JEP155 states that 500-V HBM allows safe manufacturing with a standard ESD control process. Pins listed as  $\pm$  2000 V may actually have higher performance.
- (2) JEDEC document JEP157 states that 250-V CDM allows safe manufacturing with a standard ESD control process. Pins listed as  $\pm$  500 V may actually have higher performance.

### 7.3 Recommended Operating Conditions

over operating temperature range (unless otherwise noted)

			MIN	NOM	MAX	UNIT
V <sub>VM</sub>	Power supply voltage, DSG	VM	1.65		11	V
V <sub>VM</sub>	Power supply voltage, RTE	VM	0		11	V
V <sub>VCC</sub>	Power supply voltage, RTE	VCC	1.65		5.5	V
V <sub>IN</sub>	Logic input voltage	IN1, IN2, nSLEEP, IMODE, SMODE, GAINSEL	0		5.5	V
f <sub>PWM</sub>	PWM frequency	IN1, IN2	0		100	kHz
V <sub>OD</sub>	Open drain pullup voltage	nFAULT, nSTALL	0		5.5	V
I <sub>OD</sub>	Open drain output current	nFAULT, nSTALL	0		5	mA
I <sub>OUT</sub> <sup>(1)</sup>	Peak output current	OUTx	0		4	A
I <sub>IPROPI</sub>	Current sense output current	IPROPI	0		1	mA

over operating temperature range (unless otherwise noted)

			MIN	NOM	MAX	UNIT
$V_{VREF}$	Current limit reference voltage	$V_{REF}$	0		min (3.3, $V_{VM} - 1.25$ )	V
$T_A$	Operating ambient temperature		-40		125	°C
$T_J$	Operating junction temperature		-40		150	°C

(1) Power dissipation and thermal limits must be observed

## 7.4 Thermal Information

THERMAL METRIC <sup>(1)</sup>		DEVICE	DEVICE	UNIT
		DSG (WSON)	RTE (WQFN)	
		8 PINS	16 PINS	
$R_{\theta JA}$	Junction-to-ambient thermal resistance	65.9	50.7	°C/W
$R_{\theta JC(top)}$	Junction-to-case (top) thermal resistance	75.2	52.0	°C/W
$R_{\theta JB}$	Junction-to-board thermal resistance	28.7	25.5	°C/W
$\Psi_{JT}$	Junction-to-top characterization parameter	2.0	1.8	°C/W
$\Psi_{JB}$	Junction-to-board characterization parameter	28.7	25.4	°C/W
$R_{\theta JC(bot)}$	Junction-to-case (bottom) thermal resistance	12.0	11.2	°C/W

(1) For more information about traditional and new thermal metrics, see the [Semiconductor and IC Package Thermal Metrics](#) application report.

## 7.5 Electrical Characteristics

DSG:  $1.65\text{ V} \leq V_{VM} \leq 11\text{ V}$ , RTE:  $0\text{ V} \leq V_{VM} \leq 11\text{ V}$  and  $1.65\text{ V} \leq V_{VCC} \leq 5.5\text{ V}$ ,  $-40^\circ\text{C} \leq T_J \leq 150^\circ\text{C}$  (unless otherwise noted). Typical values are at  $T_J = 27^\circ\text{C}$ ,  $V_{VM} = 5\text{ V}$ ,  $V_{VCC} = 3.3\text{ V}$ .

PARAMETER		TEST CONDITIONS	MIN	TYP	MAX	UNIT
<b>POWER SUPPLIES, DSG (VM)</b>						
$I_{VMQ}$	VM sleep mode current	$IN1 = IN2 = 0\text{ V}$ , after waiting $t_{AUTOSLEEP}$ , $V_{VM} = 5\text{ V}$ , $T_J = 27^\circ\text{C}$		20	60	nA
$I_{VM}$	VM active mode current	$IN1 = 3.3\text{ V}$ , $IN2 = 0\text{ V}$		1.2	1.9	mA
$t_{WAKE}$	Turnon time	Sleep mode to active mode delay			250	µs
$t_{AUTOSLEEP}$	Autosleep turnoff time	Active mode to autosleep mode delay	0.7	1	1.3	ms
$f_{VCP}$	Charge pump switching frequency			6000		kHz
<b>POWER SUPPLIES, RTE (VM, VCC)</b>						
$I_{VMQ}$	VM sleep mode current	$IN1 = IN2 = 0\text{ V}$ , after waiting $t_{AUTOSLEEP}$ , $V_{VM} = 5\text{ V}$ , $V_{VCC} = 3.3\text{ V}$ , $T_J = 27^\circ\text{C}$		10	20	nA
$I_{VM}$	VM active mode current	$IN1 = 3.3\text{ V}$ , $IN2 = 0\text{ V}$ , $V_{VM} = 5\text{ V}$ , $V_{VCC} = 3.3\text{ V}$		0.83	1	mA
$I_{VCCQ}$	VCC sleep mode current	$IN1 = IN2 = 0\text{ V}$ , after waiting $t_{AUTOSLEEP}$ , $V_{VM} = 5\text{ V}$ , $V_{VCC} = 3.3\text{ V}$ , $T_J = 27^\circ\text{C}$		6	12	nA
$I_{VCC}$	VCC active mode current	$IN1 = 3.3\text{ V}$ , $IN2 = 0\text{ V}$ , $V_{VM} = 5\text{ V}$ , $V_{VCC} = 3.3\text{ V}$		0.46	0.6	mA
$t_{WAKE}$	Turnon time	Sleep mode to active mode delay			250	µs
$t_{AUTOSLEEP}$	Autosleep turnoff time	Active mode to autosleep mode delay	0.75	0.9	1.05	ms
<b>LOGIC-LEVEL INPUTS (IN1, IN2)</b>						
$V_{IL}$	Input logic low voltage		0		0.4	V
$V_{IH}$	Input logic high voltage		1.45		5.5	V
$V_{HYS}$	Input hysteresis		40			mV
$I_{IL}$	Input logic low current	$V_I = 0\text{ V}$	-1		1	µA

DSG:  $1.65\text{ V} \leq V_{VM} \leq 11\text{ V}$ , RTE:  $0\text{ V} \leq V_{VM} \leq 11\text{ V}$  and  $1.65\text{ V} \leq V_{VCC} \leq 5.5\text{ V}$ ,  $-40^\circ\text{C} \leq T_J \leq 150^\circ\text{C}$  (unless otherwise noted).  
Typical values are at  $T_J = 27^\circ\text{C}$ ,  $V_{VM} = 5\text{ V}$ ,  $V_{VCC} = 3.3\text{ V}$ .

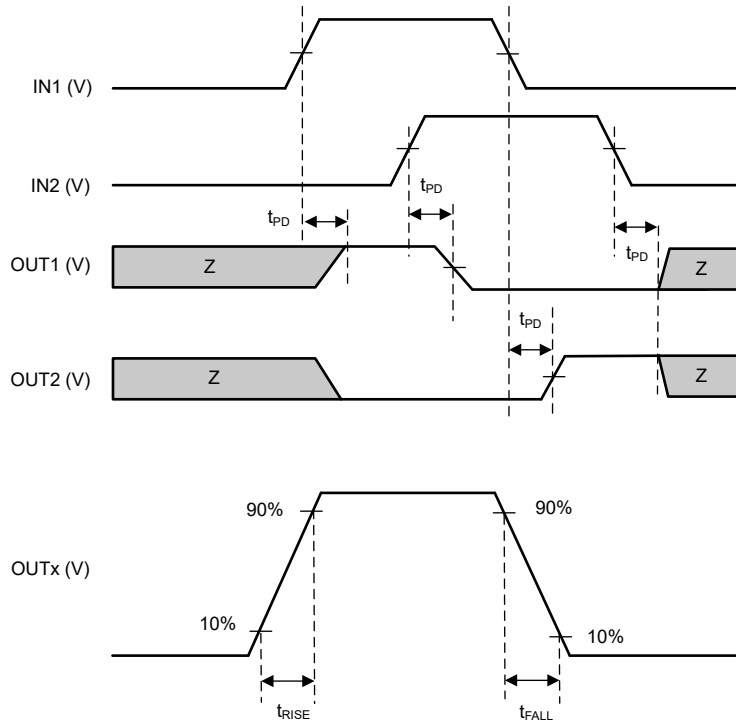
PARAMETER		TEST CONDITIONS	MIN	TYP	MAX	UNIT
I <sub>IH</sub>	Input logic high current	V <sub>INx</sub> = 5 V	15		35	μA
		V <sub>nSTALL</sub> = V <sub>CC</sub>			40	nA
R <sub>PD</sub>	Input pulldown resistance, INx			200		kΩ
t <sub>DEGLITCH</sub>	Input logic deglitch, INx			50		ns
<b>TRI-LEVEL INPUTS (IMODE, SMODE)</b>						
V <sub>THYS</sub>	Tri-level input logic low voltage		0		0.4	V
I <sub>TIL</sub>	Tri-level input Hi-Z voltage		0.75		1.05	V
I <sub>TIZ</sub>	Tri-level input logic high voltage		1.45		5.5	V
R <sub>TPD</sub>	Tri-level pulldown resistance	to GND		83		kΩ
I <sub>TPU</sub>	Tri-level pullup current	to V <sub>CC</sub>		10.5		μA
<b>OPEN-DRAIN OUTPUTS (nFAULT, nSTALL)</b>						
V <sub>OL</sub>	Output logic low voltage	I <sub>OD</sub> = 5 mA			0.4	V
I <sub>OZ</sub>	Output logic high current	V <sub>OD</sub> = V <sub>CC</sub>	-1		1	μA
<b>DRIVER OUTPUTS (OUTx)</b>						
R <sub>DS(ON)_HS</sub>	High-side MOSFET on resistance	I <sub>OUTx</sub> = 1 A		120	280	mΩ
R <sub>DS(ON)_LS</sub>	Low-side MOSFET on resistance, 350mA to 2A	GAINSEL = Low		120	260	mΩ
R <sub>DS(ON)_LS</sub>	Low-side MOSFET on resistance, 60mA to 350mA	GAINSEL = High-Z		460	900	mΩ
R <sub>DS(ON)_LS</sub>	Low-side MOSFET on resistance, 10mA to 60mA	GAINSEL = High		2100	4000	mΩ
V <sub>SD</sub>	Body diode forward voltage	I <sub>OUTx</sub> = -1 A		0.9		V
t <sub>RISE</sub>	Output rise time	V <sub>OUTx</sub> rising from 10% to 90% of V <sub>VM</sub>		70		ns
t <sub>FALL</sub>	Output fall time	V <sub>OUTx</sub> falling from 90% to 10% of V <sub>VM</sub>		40		ns
t <sub>PDR</sub>	Input high to output high propagation delay	Input to OUTx		450		ns
t <sub>PDF</sub>	Input low to output low propagation delay	Input to OUTx		450		ns
t <sub>DEAD</sub>	Output dead time			500		ns
<b>CURRENT SENSE AND REGULATION (IPROPI, VREF)</b>						
V <sub>REF_INT</sub>	Internal reference voltage	SMODE = Open for RTE package and for DSG package	470	510	550	mV
A <sub>IPROPI_H</sub>	Current scaling factor	GAINSEL = Low		205		μA/A
A <sub>IPROPI_M</sub>	Current scaling factor	GAINSEL = High-Z		1050		μA/A
A <sub>IPROPI_L</sub>	Current scaling factor	GAINSEL = High		4900		μA/A
A <sub>ERR_H</sub>	Current mirror total error, 350 mA to 2 A	GAINSEL = Low, V <sub>IPROPI</sub> ≤ min(V <sub>M</sub> -1.25 V, 3.3 V), 3.3 V ≤ V <sub>VM</sub> ≤ 11 V	-6		6	%
A <sub>ERR_H</sub>	Current mirror total error, 350 mA to 2 A	GAINSEL = Low, V <sub>IPROPI</sub> ≤ min(V <sub>M</sub> -1.25 V, 3.3 V), 1.65 V ≤ V <sub>VM</sub> ≤ 3.3 V	-6		6	%
A <sub>ERR_M</sub>	Current mirror total error, 60 mA to 350 mA	GAINSEL = High-Z, V <sub>IPROPI</sub> ≤ min(V <sub>M</sub> -1.25 V, 3.3 V), 3.3 V ≤ V <sub>VM</sub> ≤ 11 V	-6		6	%
		GAINSEL = High-Z, V <sub>IPROPI</sub> ≤ min(V <sub>M</sub> -1.25 V, 3.3 V), 1.65 V ≤ V <sub>VM</sub> ≤ 3.3 V	-6		6	%
A <sub>ERR_L</sub>	Current mirror total error, 10 mA to 60 mA	GAINSEL = High, V <sub>IPROPI</sub> ≤ min(V <sub>M</sub> -1.25 V, 3.3 V), 3.3 V ≤ V <sub>VM</sub> ≤ 11 V	-6		6	%
		GAINSEL = High, V <sub>IPROPI</sub> ≤ min(V <sub>M</sub> -1.25 V, 3.3 V), 1.65 V ≤ V <sub>VM</sub> ≤ 3.3 V	-6		6	%
t <sub>OFF</sub>	Current regulation off time			20		μs

DSG:  $1.65\text{ V} \leq V_{VM} \leq 11\text{ V}$ , RTE:  $0\text{ V} \leq V_{VM} \leq 11\text{ V}$  and  $1.65\text{ V} \leq V_{VCC} \leq 5.5\text{ V}$ ,  $-40^\circ\text{C} \leq T_J \leq 150^\circ\text{C}$  (unless otherwise noted).  
 Typical values are at  $T_J = 27^\circ\text{C}$ ,  $V_{VM} = 5\text{ V}$ ,  $V_{VCC} = 3.3\text{ V}$ .

PARAMETER		TEST CONDITIONS	MIN	TYP	MAX	UNIT
$t_{\text{BLANK}}$	Current regulation blanking time			1.8		$\mu\text{s}$
$t_{\text{DELAY}}$	Current sense delay time			1.5		$\mu\text{s}$
$t_{\text{DEG}}$	Current regulation and stall detection deglitch time			2		$\mu\text{s}$
<b>HARDWARE STALL DETECTION (TINRUSH)</b>						
$V_{\text{TINRUSH\_trip}}$	Threshold voltage for setting $t_{\text{INRUSH}}$ timing		0.97	1	1.03	V
$I_{\text{TINRUSH}}$	Current sourced out of the TINRUSH pin	Inputs transition to a state other than $\text{IN1}=\text{IN2}=0$ , $V_{\text{TINRUSH}} < V_{\text{TINRUSH\_trip}}$	8	10	12	$\mu\text{A}$
$t_{\text{discharge}}$	TINRUSH capacitor discharge time	$0.8\text{ nF} \leq C_{\text{TINRUSH}} \leq 0.8\text{ }\mu\text{F}$			100	$\mu\text{s}$
$t_{\text{STALL\_RETRY}}$	$\text{IN1}/\text{IN2} = 0/0$ duration to recover from Stall (retry type)		350		900	$\mu\text{s}$
<b>PROTECTION CIRCUITS</b>						
$V_{\text{UVLO\_VM}}$	VM supply undervoltage lockout (UVLO), DSG	Supply rising			1.65	V
		Supply falling	1.30			V
$V_{\text{UVLO\_VCC}}$	VCC supply undervoltage lockout (UVLO), RTE	Supply rising			1.65	V
		Supply falling	1.30			V
$V_{\text{UVLO\_HYS}}$	Supply UVLO hysteresis	Rising to falling threshold		150		mV
$t_{\text{UVLO}}$	Supply undervoltage deglitch time	$V_{VM}$ falling (DSG) or $V_{VCC}$ falling (RTE) to $\text{OUTx}$ disabled		10		$\mu\text{s}$
$I_{\text{OCP}}$	Overcurrent protection trip point, 350mA to 2A		4			A
$I_{\text{OCP}}$	Overcurrent protection trip point, 60mA to 350mA		0.8			A
$I_{\text{OCP}}$	Overcurrent protection trip point, 10mA to 60mA		0.16			A
$t_{\text{OCP}}$	Overcurrent protection deglitch time			4.2		$\mu\text{s}$
$t_{\text{RETRY}}$	Fault retry time			1.5		ms
$T_{\text{TSD}}$	Thermal shutdown temperature		165	175	185	$^\circ\text{C}$
$T_{\text{HYS}}$	Thermal shutdown hysteresis			17		$^\circ\text{C}$

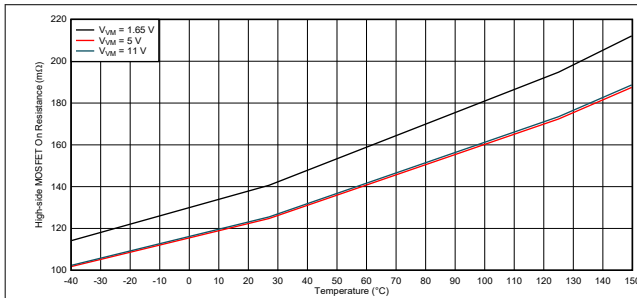


## 7.6 Timing Diagrams

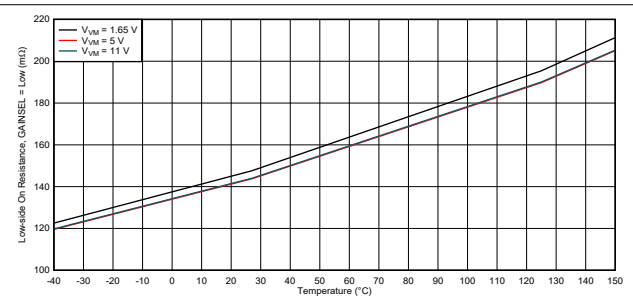


**Figure 7-1. Input-to-Output Timing**

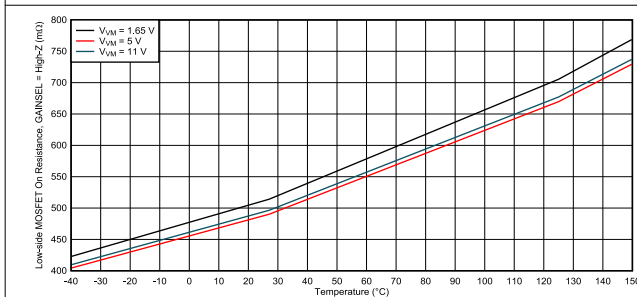
## 7.7 Typical Operating Characteristics



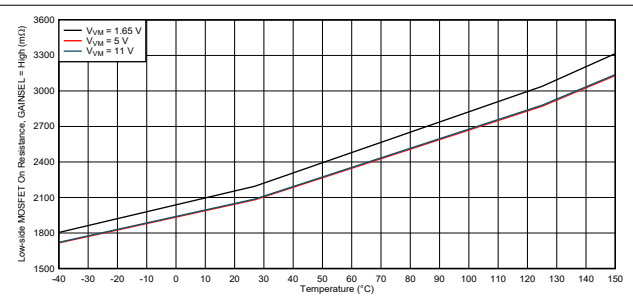
**Figure 7-2. High-Side MOSFET ON Resistance (DSG Package)**



**Figure 7-3. Low-Side MOSFET ON Resistance with GAINSEL = Low (DSG Package)**



**Figure 7-4. Low-Side MOSFET ON Resistance with GAINSEL = High-Z (DSG Package)**



**Figure 7-5. Low-Side MOSFET ON Resistance with GAINSEL = High (DSG Package)**

## 7.7 Typical Operating Characteristics (continued)

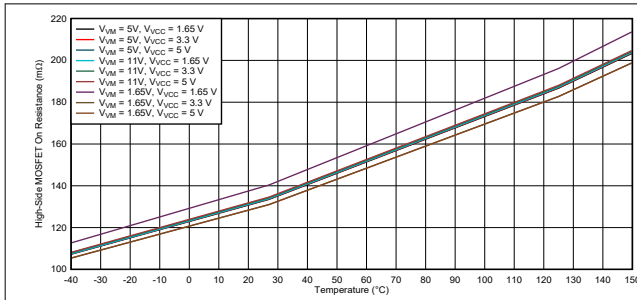


Figure 7-6. High-Side MOSFET ON Resistance (RTE Package)

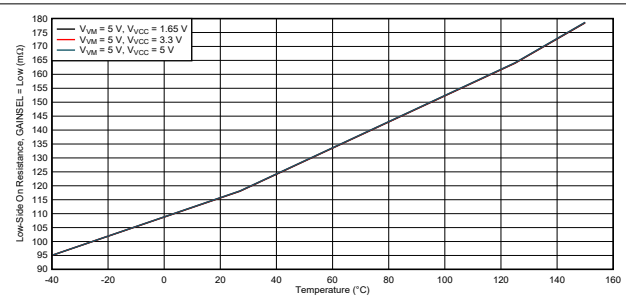


Figure 7-7. Low-Side MOSFET ON Resistance with GAINSEL = Low (RTE Package)

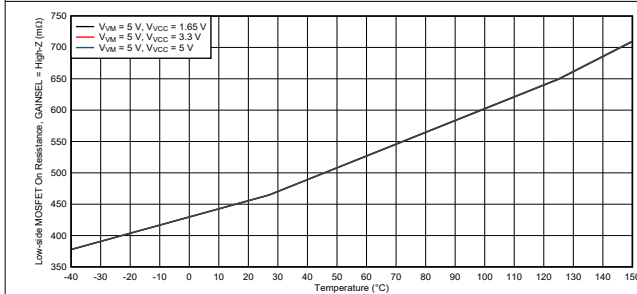


Figure 7-8. Low-Side MOSFET ON Resistance with GAINSEL = High-Z (RTE Package)

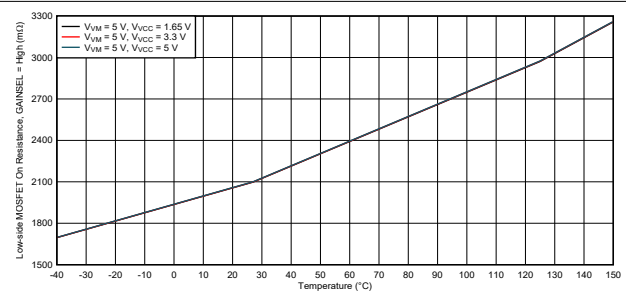


Figure 7-9. Low-Side MOSFET ON Resistance with GAINSEL = High (RTE Package)

## 8 Detailed Description

### 8.1 Overview

DRV8213 is a full-bridge driver with integrated current sense, current regulation, and current sense output. To reduce area and external components on a printed circuit board, the device integrates a charge pump regulator and capacitors. In the WQFN (RTE) package, the separate full-bridge (VM) and logic (VCC) supplies allow the full-bridge supply voltage to drop to 0 V without significant impact to  $R_{DS(ON)}$  and without triggering UVLO as long as the VCC supply is stable. In the WSON (DSG) package, a single power input (VM) serves as both device power and the full-bridge supply for small design size. An auto-sleep mode reduces microcontroller GPIO connections by eliminating a disable/sleep pin and automatically putting the device into a low-power sleep mode when the PWM inputs remain low for  $t_{AUTOSLEEP}$ .

The DRV8213 uses a standard 2-pin (IN1/IN2) PWM interface. The IN1/IN2 pins control the full bridge, which consists of four N-channel MOSFETs that have a typical  $R_{DS(ON)}$  of 240 m $\Omega$  (including one high-side and one low-side FET). Motor speed can be controlled with pulse-width modulation (PWM), at frequencies between 0 to 100 kHz.

The integrated current regulation feature limits motor current to a predefined maximum based on the VREF and IPROPI settings. The IPROPI signal can provide current feedback to a microcontroller during both the drive and brake/slow-decay states of the H-bridge.

The gain select (GAINSEL) feature allows high accuracy current sensing down to 10 mA average motor current. The  $R_{DS(ON)}$  of the low-side MOSFET and the overcurrent protection limit changes according to the GAINSEL setting, thereby leading to optimized answers for different applications and different values of motor current.

In the WQFN package (RTE), the DRV8213 has additional pins to configure a hardware stall detection feature based on the IPROPI current sensing signal.

The integrated protection features protect the device in the case of a system fault. These include undervoltage lockout (UVLO), overcurrent protection (OCP), and overtemperature shutdown (TSD).

## 8.2 Functional Block Diagram

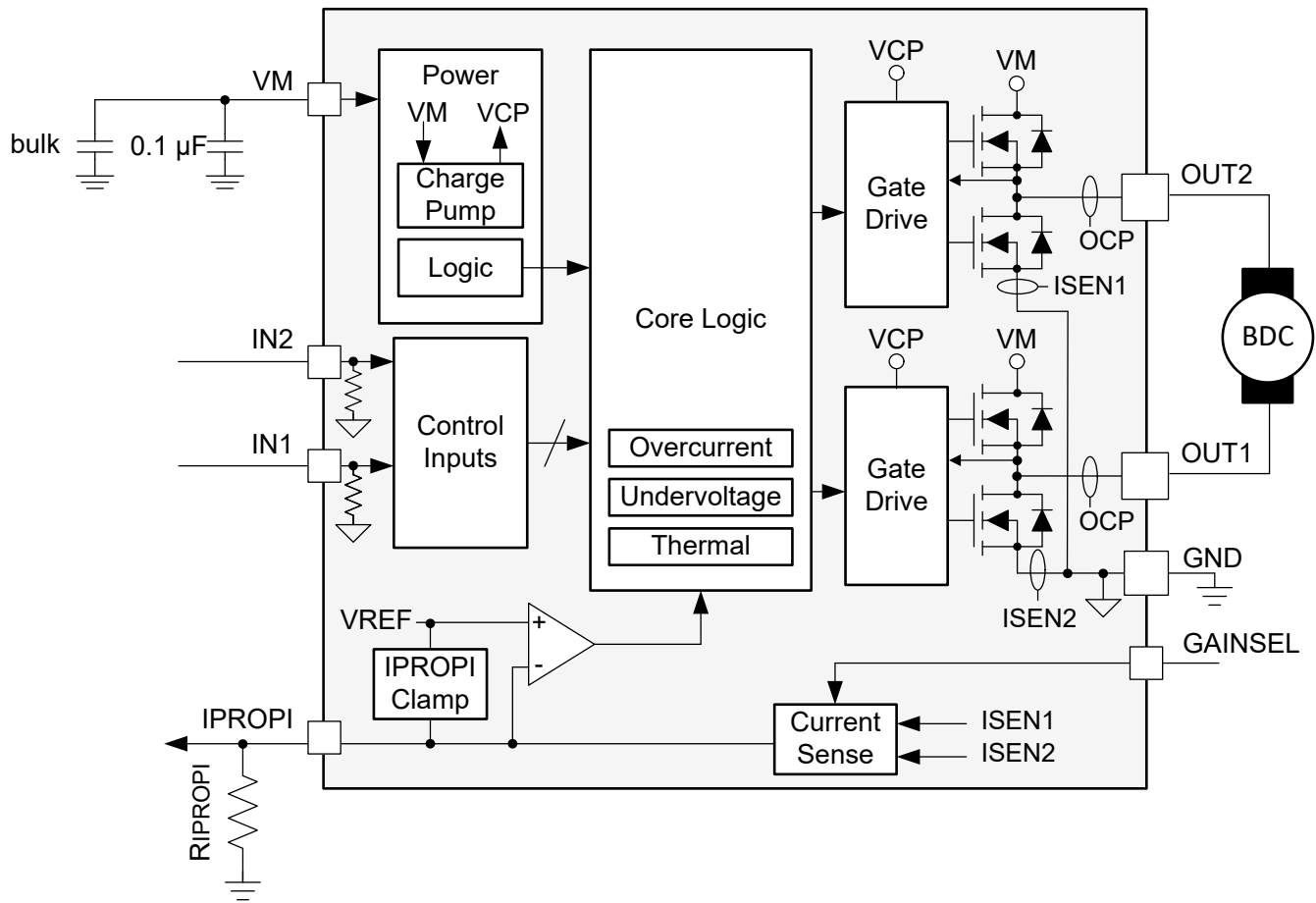


Figure 8-1. DRV8213 in WSON (DSG) package with single supply pin

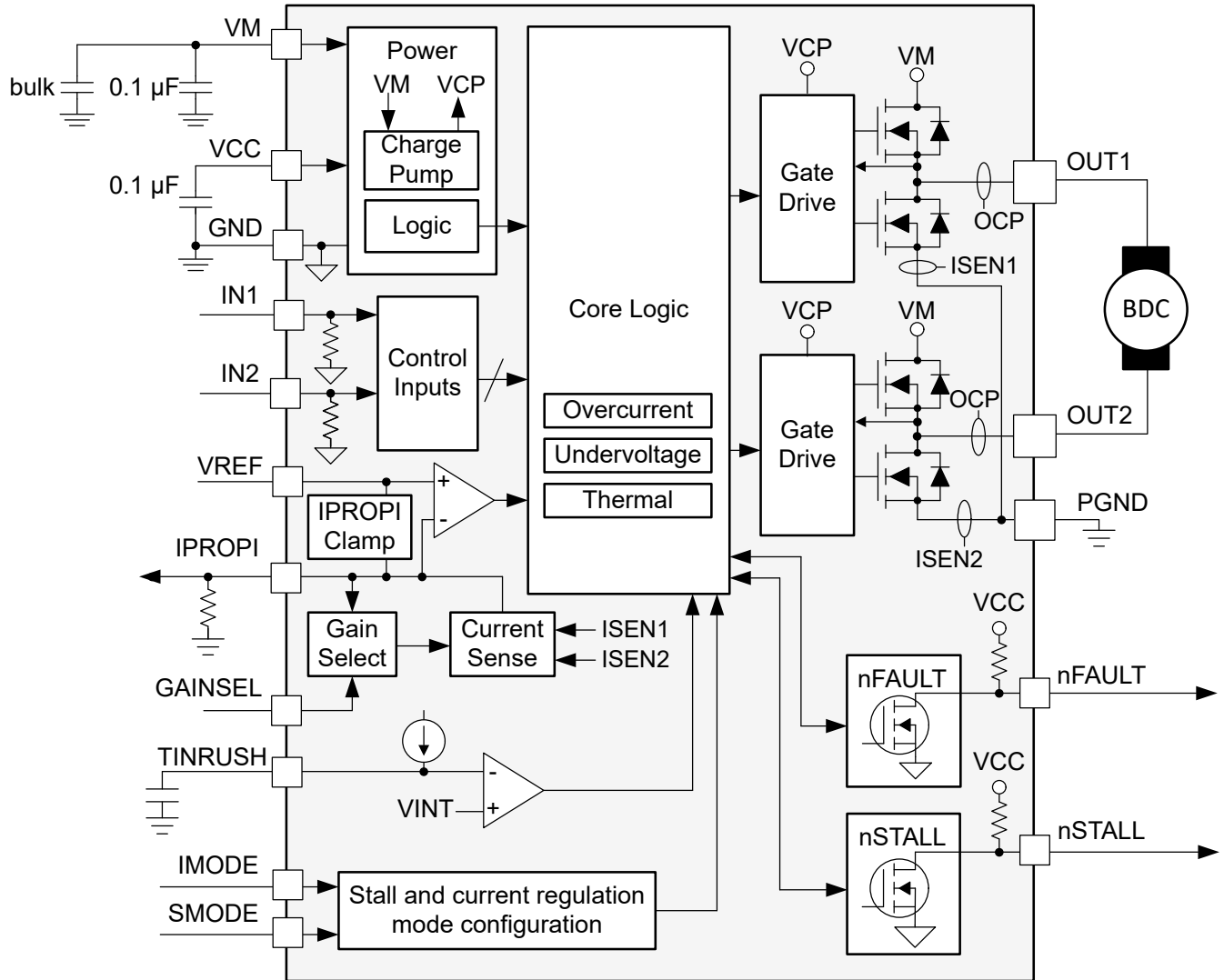


Figure 8-2. DRV8213 in WQFN (RTE) package with stall detection and dual supply pins

### 8.3 External Components

Table 8-1 lists the recommended external components for the device.

Table 8-1. Recommended external components

COMPONENT	PIN 1	PIN 2	RECOMMENDED
$C_{VM1}$	VM	GND	0.1- $\mu$ F, low ESR ceramic capacitor, VM-rated
$C_{VM2}$	VM	GND	Section 10.1, VM-rated
$C_{VCC}$	VCC	GND	0.1- $\mu$ F, low ESR ceramic capacitor, VM-rated
$R_{IPROPI}$	IPROPI	GND	Resistor from IPROPI pin to GND, sets the current regulation level
$C_{INRUSH}$	TINRUSH	GND	Sets the inrush current blanking time
$R_{nFAULT}$	VCC	nFAULT	10 k $\Omega$
$R_{nSTALL}$	VCC	nSTALL	10 k $\Omega$

## 8.4 Feature Description

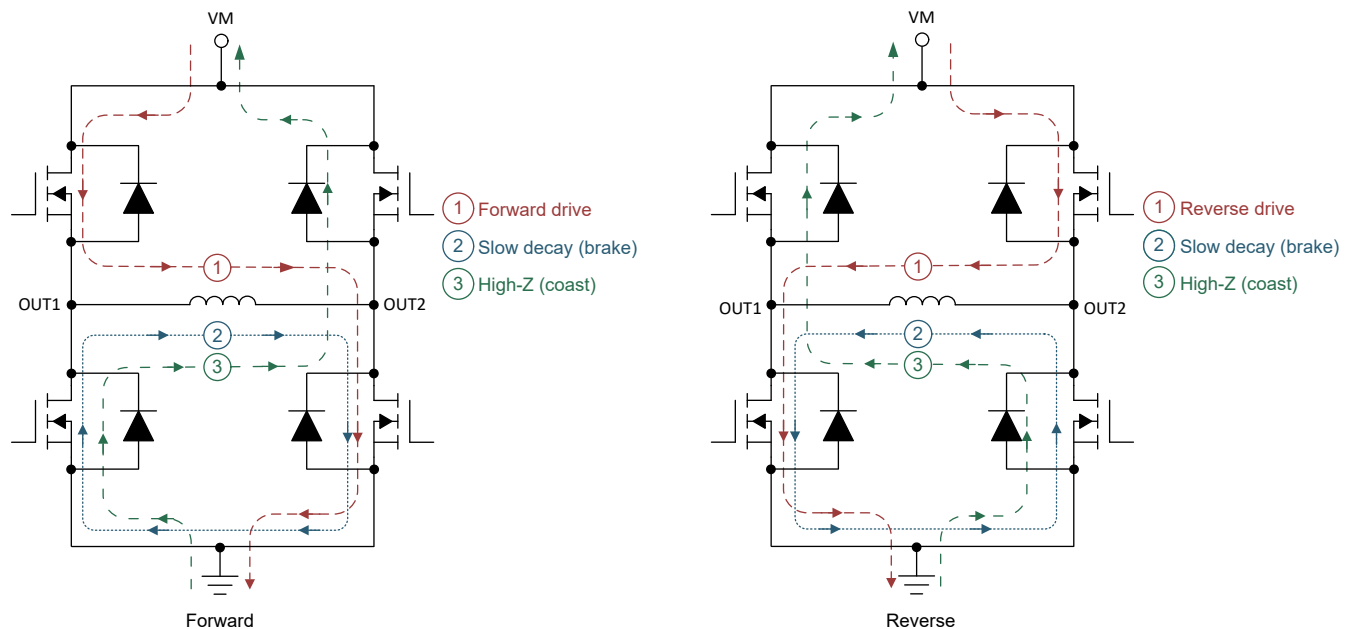
### 8.4.1 Bridge Control

The DRV8213 output consists of four N-channel MOSFETs designed to drive high current. These outputs are controlled by the two PWM inputs IN1 and IN2 as listed in [Table 8-2](#).

**Table 8-2. H-Bridge Control**

IN1	IN2	OUT1	OUT2	DESCRIPTION
0	0	High-Z	High-Z	Coast; H-bridge disabled to High-Z (sleep entered after $t_{AUTOSLEEP}$ )
0	1	L	H	Reverse (Current OUT2 → OUT1)
1	0	H	L	Forward (Current OUT1 → OUT2)
1	1	L	L	Brake; low-side slow decay

The inputs can be set to static voltages for 100% duty cycle drive, or they can be pulse-width modulated (PWM) for variable motor speed. When using PWM, switching between driving and braking typically works best. For example, to drive a motor forward with 50% of the maximum RPM, IN1 = 1 and IN2 = 0 during the driving period, and IN1 = 1 and IN2 = 1 during the other period. Alternatively, the coast mode (IN1 = 0, IN2 = 0) for *fast current decay* is also available. [Figure 8-3](#) shows how the motor current flows through the H-bridge. The input pins can be powered before VM or VCC are applied.



**Figure 8-3. H-Bridge Current Paths**

When an output changes from driving high to driving low, or driving low to driving high, dead time is automatically inserted to prevent shoot-through. The  $t_{DEAD}$  time is the time in the middle when the output is High-Z. If the output pin is measured during  $t_{DEAD}$ , the voltage depends on the direction of current. If the current is leaving the pin, the voltage is a diode drop below ground. If the current is entering the pin, the voltage is a diode drop above VM. This diode is the body diode of the high-side or low-side FET.

The propagation delay time ( $t_{PD}$ ) is measured as the time between an input edge to output change. This time accounts for input deglitch time and other internal logic propagation delays. The input deglitch time prevents noise on the input pins from affecting the output state. Additional output slew delay timing accounts for FET turn on or turn off times ( $t_{RISE}$  and  $t_{FALL}$ ).

### 8.4.2 Current Sense and Regulation (IPROPI)

The DRV8213 device integrates current sensing, regulation, and current sense feedback. The internal current mirror allows the device to sense the output current without an external sense resistor or sense circuitry, thereby reducing system size, cost, and complexity. The current regulation feature allows for the device to limit the output current in the case of motor stall or high torque events and give detailed feedback to the controller about the load current using the IPROPI output. Figure 8-4 shows the IPROPI timings specified in the Electrical Characteristics table.

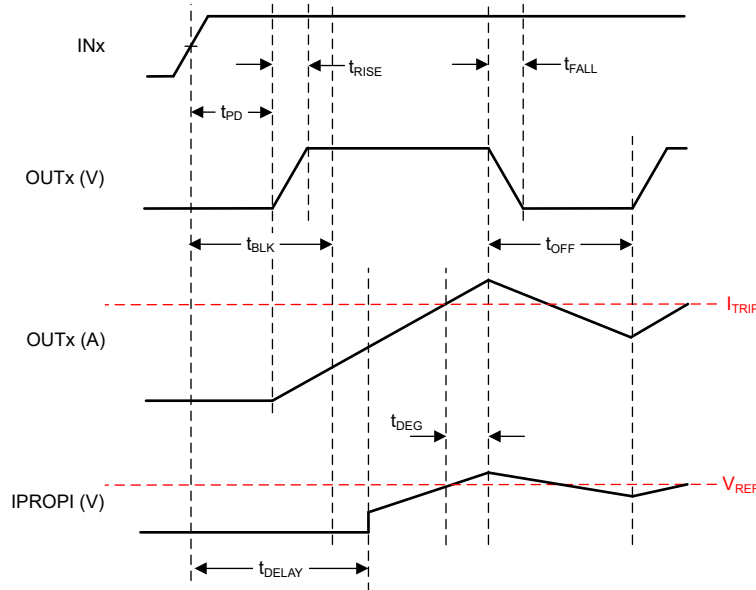


Figure 8-4. Detailed IPROPI Timing Diagram

#### 8.4.2.1 Current Sensing and Current Mirror Gain Selection

The IPROPI pin outputs an analog current proportional to the current flowing through the low-side power MOSFETs in the H-bridge and scaled by the current mirror gain ( $A_{IPROPI}$ ). The IPROPI output current can be calculated by Equation 1. The  $I_{LSx}$  in Equation 1 is only valid when the current flows from drain to source in the low-side MOSFET. If current flows from source to drain or through the body diode, the value of  $I_{LSx}$  for that channel is zero. For instance, if the bridge is in the brake, slow-decay state, then the current out of IPROPI is only proportional to the current in one of the low-side MOSFETs.

$$I_{PROPI} (\mu A) = (I_{LS1} + I_{LS2}) (A) \times A_{IPROPI} (\mu A/A) \quad (1)$$

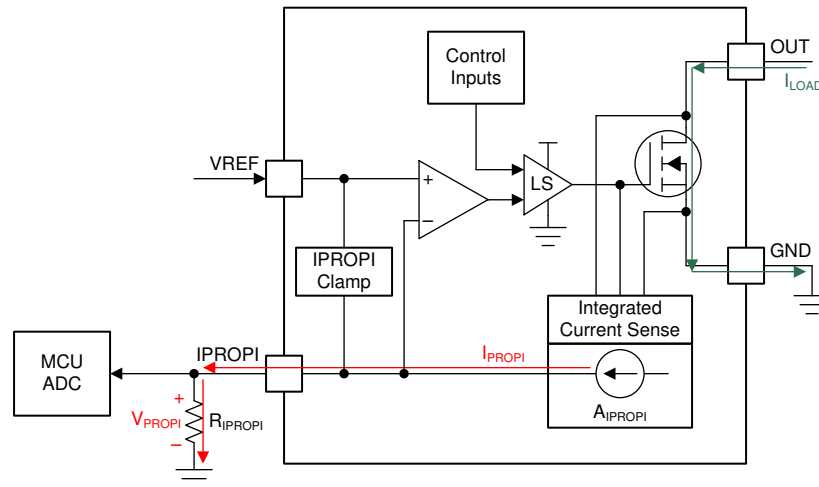
The  $A_{ERR}$  parameter in the Electrical Characteristics table is the error associated with the  $A_{IPROPI}$  gain.  $A_{ERR}$  indicates the combined effect of offset error added to the  $I_{OUT}$  current and gain error.

Depending on the application, high accuracy current sense output is required down to 10 mA current. The GAINSEL feature allows optimizing the design for different end applications by reducing OCP limit and increasing current mirror gain at lower motor currents. The current mirror gain  $A_{IPROPI}$  depends on the GAINSEL pin setting, as shown in Table 8-3.

Table 8-3. GAINSEL Setting

GAINSEL	$A_{IPROPI}$	Recommended Current Range	Low-side FET $R_{DS(ON)}$	Minimum OCP Limit
Low	205 $\mu A/A$	350 mA to 2 A	120 m $\Omega$	4 A
High-Z	1050 $\mu A/A$	60 mA to 350 mA	460 m $\Omega$	800 mA
High	4900 $\mu A/A$	10 mA to 60 mA	2100 m $\Omega$	160 mA

The motor current is measured by an internal current mirror architecture on the low-side FETs which removes the need for an external power sense resistor as shown in Figure 8-5. The current mirror architecture senses motor winding current in both the drive and brake low-side slow-decay periods, therefore allowing continuous current monitoring in typical bidirectional brushed DC motor applications. In coast mode, the current is freewheeling and cannot be sensed because the current flows from source to drain. However, the current can be sampled by briefly reenabling the driver in either drive or slow-decay modes and measuring the current before switching back to coast mode again.



Copyright © 2017, Texas Instruments Incorporated

**Figure 8-5. Integrated Current Sensing**

The IPROPI pin is connected to an external resistor ( $R_{IPROPI}$ ) to ground to generate a proportional voltage ( $V_{IPROPI}$ ) on the IPROPI pin with the  $I_{IPROPI}$  analog current output. This allows for the load current to be measured as the voltage drop across the  $R_{IPROPI}$  resistor with a standard analog to digital converter (ADC). The  $R_{IPROPI}$  resistor can be sized based on the expected load current in the application so that the full range of the controller ADC is utilized.

Additionally, the DRV8213 device implements an internal IPROPI voltage clamp circuit to limit  $V_{IPROPI}$  with respect to  $V_{VREF}$  on the VREF pin and protect the external ADC in case of output overcurrent or unexpected high current events. For the DSG package,  $V_{VREF}$  is set at 510 mV internally. TI recommends designing for at least 1.25 V of headroom between  $V_{VM}$  and the maximum  $V_{IPROPI}$  voltage to be measured by the ADC,  $V_{IPROPI\_MAX}$ . This maintains good accuracy across the range of  $V_{IPROPI}$  voltages measured by the ADC. For instance, if  $V_{VM}$  is 4.55 V to 11 V,  $V_{IPROPI\_MAX}$  can be as high as 3.3 V. However, if  $V_{VM}$  is 3.3 V, then  $V_{IPROPI}$  has good accuracy up to 2.05 V.

The corresponding IPROPI voltage to the output current can be calculated by Equation 2.

$$V_{IPROPI} (V) = I_{IPROPI} (A) \times R_{IPROPI} (\Omega) \quad (2)$$

The IPROPI output bandwidth is limited by the sense delay time ( $t_{DELAY}$ ) of the internal current sensing circuit. This time is the delay from the low-side MOSFET enable command (from the INx pins) to the IPROPI output being ready.

If the device is alternating between drive and slow-decay (brake) in an H-bridge PWM pattern then the low-side MOSFET sensing the current is continuously on and the sense delay time has no impact to the IPROPI output. If a command on the INx pins disables the low-side MOSFETs (according to the logic tables in Section 8.4.1), the IPROPI output disables with the input logic signal. Although the low-side MOSFETs still conduct current as the MOSFETs disable according to the device slew rate (noted in the Electrical Characteristics table by  $t_{RISE}$  time), IPROPI does not represent the current in the low-side MOSFETs during this turnoff time.



### 8.4.2.2 Current Regulation

The DRV8213 device integrates current regulation using a fixed off-time current chopping scheme, as shown in Figure 8-6. This allows the device to limit the output current in case of motor stall, high torque, or other high current load events without involvement from the external controller.

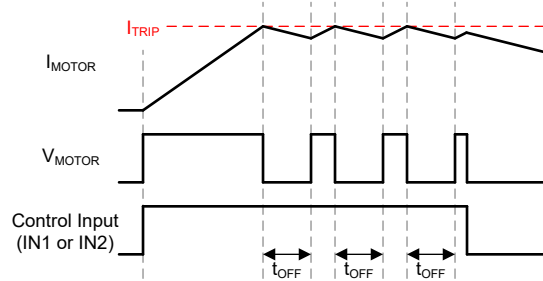


Figure 8-6. Off-Time Current-Regulation

The current chopping threshold ( $I_{TRIP}$ ) is set through a combination of the VREF voltage ( $V_{VREF}$ ) and IPROPI output resistor ( $R_{IPROPI}$ ). This is done by comparing the voltage drop across the external  $R_{IPROPI}$  resistor to  $V_{VREF}$  with an internal comparator.

$$I_{TRIP} \text{ (A)} \times A_{IPROPI} \text{ (\mu A/A)} = V_{VREF} \text{ (V)} / R_{IPROPI} \text{ (\Omega)} \quad (3)$$

For example, if  $V_{VREF} = 3.3 \text{ V}$ ,  $R_{IPROPI} = 8.06 \text{ k}\Omega$ , and  $A_{IPROPI} = 205 \text{ }\mu\text{A/A}$ , then  $I_{TRIP}$  will be approximately 2 A.

$V_{VREF}$  must be lower than  $V_{VM}$  by at least 1.25 V. The maximum recommended value of  $V_{VREF}$  is 3.3 V.

As mentioned before, for DSG package,  $V_{VREF}$  is internally fixed at 510 mV. For RTE package as well, if SMODE is left OPEN,  $V_{VREF}$  is internally fixed at 510 mV.

The fixed off-time current chopping scheme supports up to 100% duty cycle current regulation since the H-bridge automatically enables after the  $t_{OFF}$  period and does not require a new control input edge on the INx pins to reset the outputs. When the motor current exceeds the  $I_{TRIP}$  threshold, the outputs will enter a current chopping mode with a fixed off time ( $t_{OFF}$ ). During  $t_{OFF}$ , the H-bridge enters a brake/low-side slow decay state (both low-side MOSFETs ON) for  $t_{OFF}$  duration after  $I_{OUT}$  exceeds  $I_{TRIP}$ . After  $t_{OFF}$ , the outputs re-enable according to the control inputs if  $I_{OUT}$  is less than  $I_{TRIP}$ . If  $I_{OUT}$  is still greater than  $I_{TRIP}$ , the H-bridge enters another period of brake/low-side slow decay for  $t_{OFF}$  after a drive time of  $t_{BLANK}$ . If the state of the INx control pins changes during the  $t_{OFF}$  time, the remainder of the  $t_{OFF}$  time is ignored, and the outputs will again follow the inputs.

The  $I_{TRIP}$  comparator has both a blanking time ( $t_{BLK}$ ) and a deglitch time ( $t_{DEG}$ ). The internal blanking time helps to prevent voltage and current transients during output switching from effecting the current regulation. These transients may be caused by a capacitor inside the motor or on the connections to the motor terminals. The internal deglitch time ensures that transient conditions do not prematurely trigger the current regulation. In certain cases where the transient conditions are longer than the deglitch time, placing a 10-nF capacitor on the IPROPI pin, close to the device, will help filter the transients on IPROPI output so current regulation does not prematurely trigger. The capacitor value can be adjusted as needed, however large capacitor values may slow down the response time of the current regulation circuitry.

The IMODE pin determines the behavior of current regulation in the motor driver. When IMODE is logic low (IMODE = 0), current regulation is disabled. When IMODE is floating (IMODE = Z), the device only performs current regulation during the  $t_{INRUSH}$  time when stall detection is enabled. This functionality relates to the hardware stall detection feature described in Section 8.4.3. When IMODE is logic high (IMODE = 1), current regulation is enabled at all times. Table 8-4 summarizes the IMODE pin settings.

Table 8-4. IMODE configuration

IMODE	nSTALL	Description
Low	X	No current regulation at any time
High-Z	Low	Current regulation at all times

**Table 8-4. IMODE configuration (continued)**

IMODE	nSTALL	Description
High-Z	High	Current regulation during $t_{INRUSH}$ only
High	X	Current regulation at all times

### 8.4.3 Hardware Stall Detection

The DRV8213 integrates a hardware stall detection feature available in the RTE package variant. The principle of the stall detection scheme relies on the fact that motor current increases during stall conditions. The DRV8213 compares the voltage on the IPROPI pin to the voltage on the VREF pin (or 510 mV as applicable) to determine whether a stall condition has occurred. The following paragraphs describe how to configure the device pins for the desired stall detection response. For information on implementing stall detection in the DSG package variant, see [Section 9.2.1.3.1.2](#).

The nSTALL output is pulled low when stall is detected. The nSTALL pin status is latched at power-up. It requires a pull-up resistor to VCC and pulls low when a stall condition occurs. This pin can be connected to the nFAULT pin so both pins share the same pullup resistor. Combining nFAULT and nSTALL signals reduces board area needed by external components and number of input pins on the controller to detect fault and stall conditions. By having separate pullup resistors for the nSTALL and nFAULT, the microcontroller can detect a device fault separate from a stall condition using two input pins. Connecting nSTALL directly to GND disables stall detection. [Table 8-5](#) summarizes the nSTALL pin settings.

**Table 8-5. nSTALL configuration**

nSTALL	Description
0 V	Stall detection disabled. Float TINRUSH. If IMODE = High-Z, current regulation will occur at all times when $V_{IPROPI} \geq V_{VREF}$ .
Pull-up resistor to VCC	Stall detection enabled. Pin pulls low to indicate a stall.

The IPROPI pin provides the current sense signal for the hardware stall detection feature. The VREF pin sets the  $I_{TRIP}$  current level at which a stall condition is detected. For DSG package, or RTE package and SMODE = High-Z,  $V_{VREF}$  is internally fixed at 510 mV. When  $V_{IPROPI} \geq V_{VREF}$ , then  $I_{OUT} \geq I_{TRIP}$ , and the device will detect a stall condition if the  $t_{INRUSH}$  time has passed. The IPROPI and VREF pins are also responsible for current regulation, as described in [Section 8.4.2](#).

The TINRUSH pin sets the amount of time that the stall detection scheme will ignore the inrush current during motor startup ( $t_{INRUSH}$ ). When the input pins transition from the state  $IN1 = IN2 =$  logic low to any other logic combination, the TINRUSH pin sources 10  $\mu$ A of current into the capacitor ( $C_{INRUSH}$ ) connected from TINRUSH pin to ground. Once the voltage of the TINRUSH pin exceeds 1 V, the device discharges the capacitor in less than 100  $\mu$ s. The capacitor charging time is internally multiplied by 65 to determine the  $t_{INRUSH}$  time. After  $t_{INRUSH}$  time expires, the DRV8213 indicates a stall condition the next time  $V_{IPROPI}$  is greater than or equal to  $V_{VREF}$ .

The following conditions cause the stall detection scheme to ignore the inrush current for  $t_{INRUSH}$  time -

- Power-up of the DRV8213
- Recovering from faults
- After device exits from sleep mode
- After recovering from stall, as explained in [Table 8-6](#)

Use the following formula to select the  $C_{INRUSH}$  capacitor -

$$t_{INRUSH} = 6.5 \times 10^6 \times C_{INRUSH}$$

The SMODE pin sets the device's response to a stall condition. The device decides that a stall condition has occurred when  $V_{IPROPI}$  is greater than or equal to  $V_{VREF}$  and the  $t_{INRUSH}$  time has elapsed. When SMODE = logic low, the outputs disable, and the nSTALL pin latches low. When SMODE = logic high, the nSTALL pin still latches low, but the outputs continue to drive current into the motor. When SMODE = Hi-z, the device uses internal  $V_{VREF}$  (510 mV) for stall detection, the nSTALL pin still latches low, but the outputs continue to drive current into the motor. [Table 8-6](#) summarizes the SMODE pin settings.

Table 8-6. SMODE configuration

SMODE	Description	Recovery from Stall Condition
0	Latched disable with indication: the OUTx pins disable and the nSTALL pin pulls low.	To recover from this condition, device needs to enter sleep mode. nSTALL will go high after IN1 and IN2 are both low for $t_{SLEEP}$ . After waking up from sleep mode, the stall detection scheme ignores the inrush current for $t_{INRUSH}$ time.
1	Indication only: the OUTx pins remain active and the nSTALL pin pulls low.	nSTALL goes high if stall condition is not observed and if IN1 and IN2 are both low for stall retry time ( $t_{STALL\_RETRY}$ ).
Hi-z	Indication only: the OUTx pins remain active and the nSTALL pin pulls low. Device uses internal $V_{VREF}$ (510 mV) for stall detection.	After $t_{INRUSH}$ time, if motor current is still higher than $I_{TRIP}$ , nSTALL pin is pulled low again.

The stall retry time ( $t_{STALL\_RETRY}$ ) is implemented such that it is always lower than the autosleep turnoff time ( $t_{AUTOSLEEP}$ ).

The **IMODE** pin determines the behavior of current regulation in the motor driver. When IMODE is floating (IMODE = High-Z), the device only performs current regulation during the  $t_{INRUSH}$  time. Table 8-4 summarizes the IMODE pin settings. For more details on current regulation, see Section 8.4.2.2.

The following diagrams show example timing diagrams for different configurations of the hardware stall detection feature.

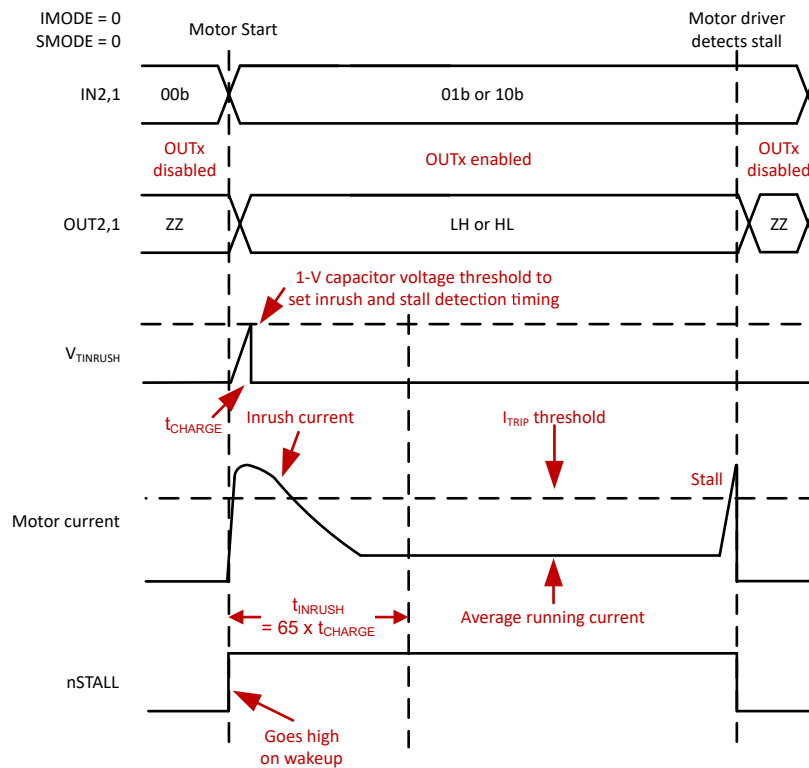
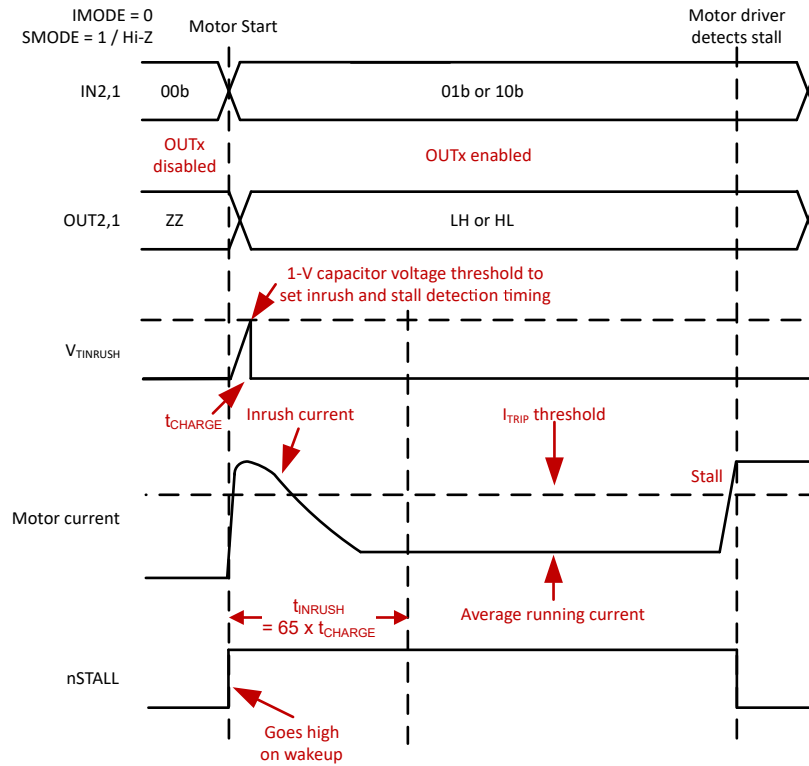
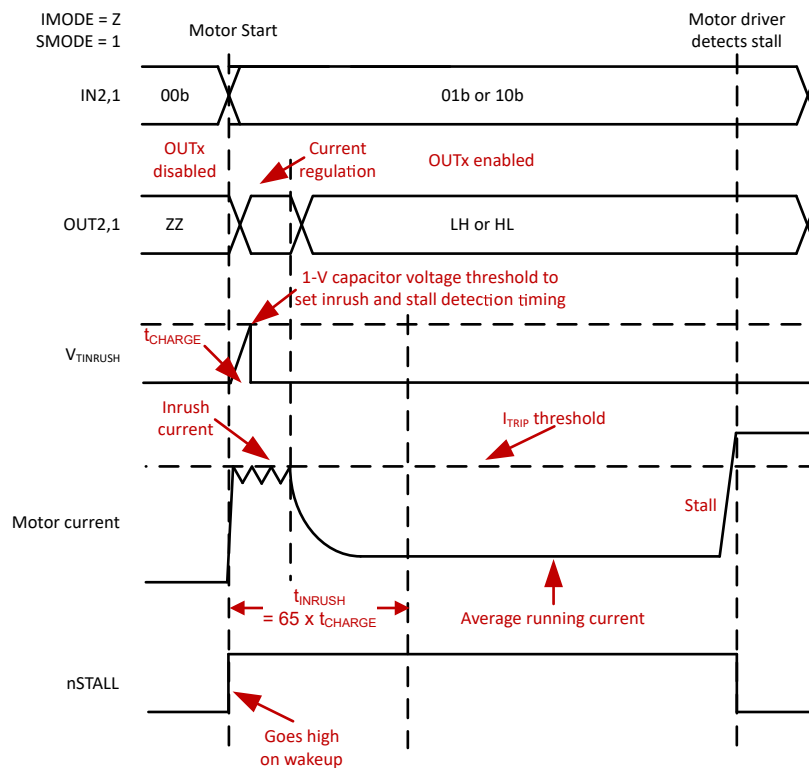


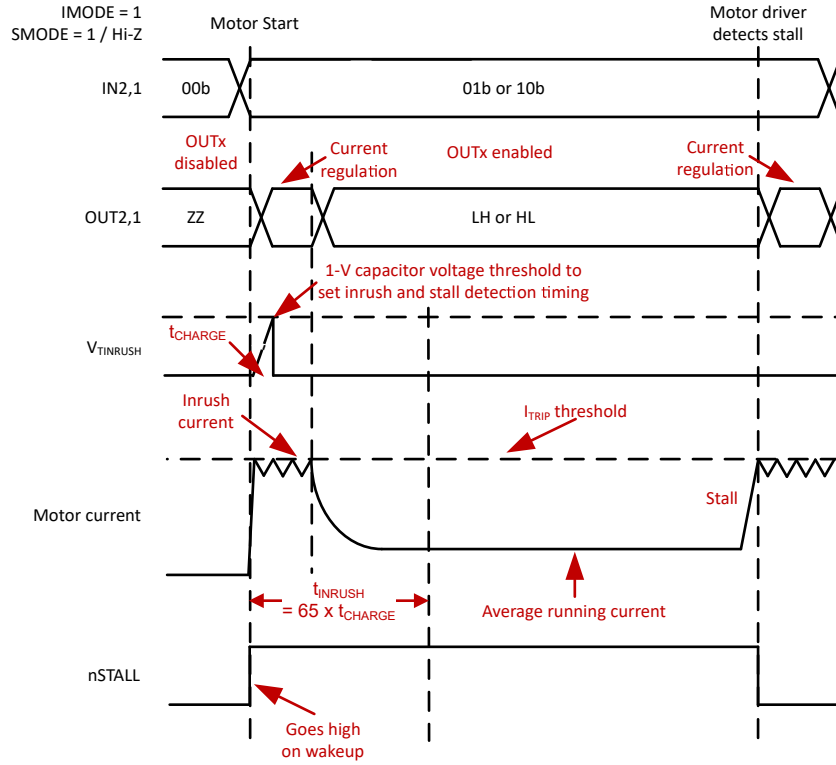
Figure 8-7. Stall Detection with Latched Disable



**Figure 8-8. Stall Detection with nSTALL indication only**



**Figure 8-9. Stall regulation with current regulation during inrush**



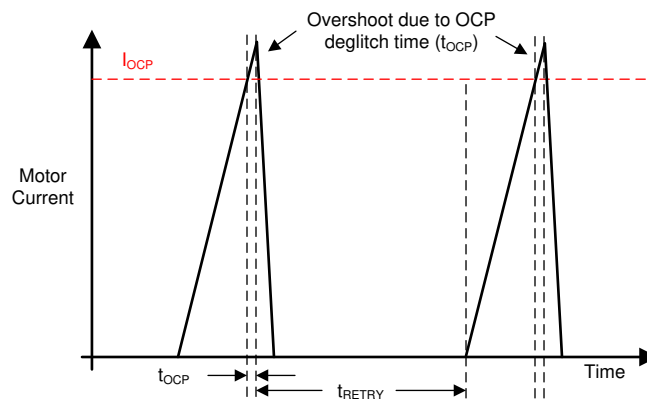
**Figure 8-10. Stall detection with current regulation**

## 8.4.4 Protection Circuits

The DRV8213 device is fully protected against supply undervoltage, overcurrent, and overtemperature events.

### 8.4.4.1 Overcurrent Protection (OCP)

An analog current limit circuit on each FET limits the current through the FET by limiting the gate drive internally. If this analog current limit persists for longer than the OCP deglitch time ( $t_{OCP}$ ), all FETs in the H-bridge will disable and nFAULT is pulled low. The driver re-enables after the fault retry period ( $t_{RETRY}$ ) has passed. If the fault condition is still present, the cycle repeats as shown in [Figure 8-11](#).



**Figure 8-11. OCP Operation**

Overcurrent conditions are detected independently on both high- and low-side FETs. This means that a short to ground, supply, or across the motor winding will all result in an overcurrent shutdown. Overcurrent protection does not use the current sense circuitry used for current regulation, so it functions regardless of VREF and IPROPI settings.

### 8.4.4.2 Thermal Shutdown (TSD)

If the die temperature exceeds the thermal shutdown temperature threshold ( $T_{TSD}$ ), all FETs in the H-bridge are disabled and nFAULT is pulled low. The driver re-enables after the fault retry period ( $t_{RETRY}$ ) has passed. If the fault condition is still present, the cycle repeats.

### 8.4.4.3 VM Undervoltage Lockout (UVLO)

Whenever the supply voltage falls below the UVLO falling threshold voltage,  $V_{UVLO}$ , all circuitry in the device is disabled, the output FETS are disabled, all internal logic is reset and nFAULT is pulled low. When powered by split supplies (RTE package only), the UVLO triggers when the VCC pin voltage drops below  $V_{UVLO\_VCC}$  falling threshold. This allows the VM supply to dip all the way to 0 V. When operating from a single supply (DSG package only), the UVLO triggers when the VM pin voltage drops below  $V_{UVLO\_VM}$  falling threshold. Normal operation resumes when the supply voltage rises above the  $V_{UVLO}$  rising threshold as shown in [Figure 8-12](#). [Table 8-7](#) summarizes the conditions when the device enters UVLO.

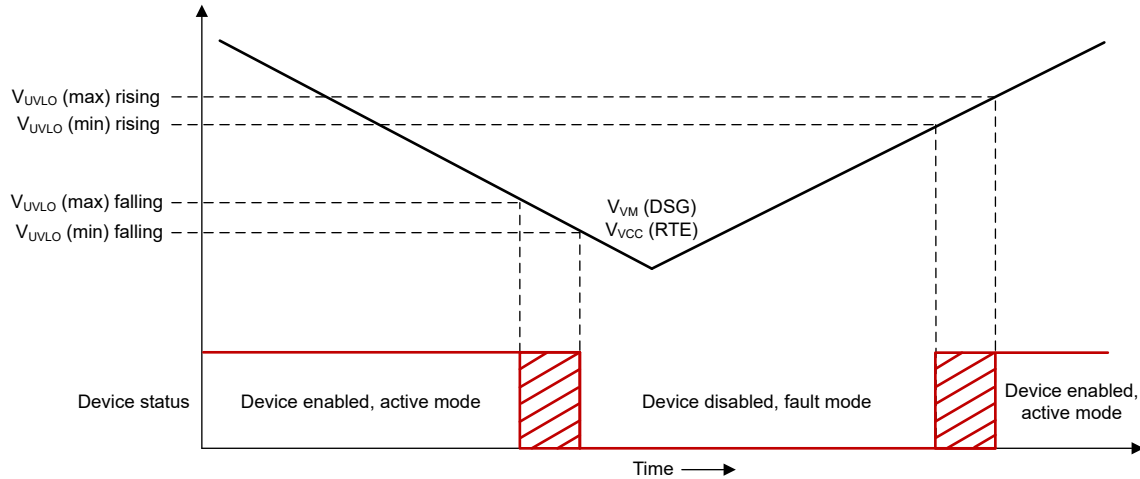


Figure 8-12. UVLO Operation

Table 8-7. UVLO response conditions

Package variant	$V_{VM}$	$V_{VCC}$	Device Response	I <sub>PROPI</sub>
RTE	0 V to $V_{VM\_MAX}$	<1.65 V	UVLO	Not available
	0 V to $V_{VM\_MAX}$	>1.65 V	Normal Operation	Available for $V_{VM} > 1.65$ V
DSG	<1.65 V	N/A	UVLO	Not available
	1.65 V to $V_{VM\_MAX}$	N/A	Normal Operation	Available

## 8.5 Device Functional Modes

Table 8-8 summarizes the DRV8213 functional modes described in this section.

Table 8-8. Modes of Operation

MODE	CONDITION	H-BRIDGE	INTERNAL CIRCUITS
Active Mode	IN1 or IN2 = logic high	Operating	Operating
Low-Power Sleep Mode	IN1 = IN2 = logic low	Disabled	Disabled
Fault Mode	Any fault condition met	Disabled	See Table 8-9

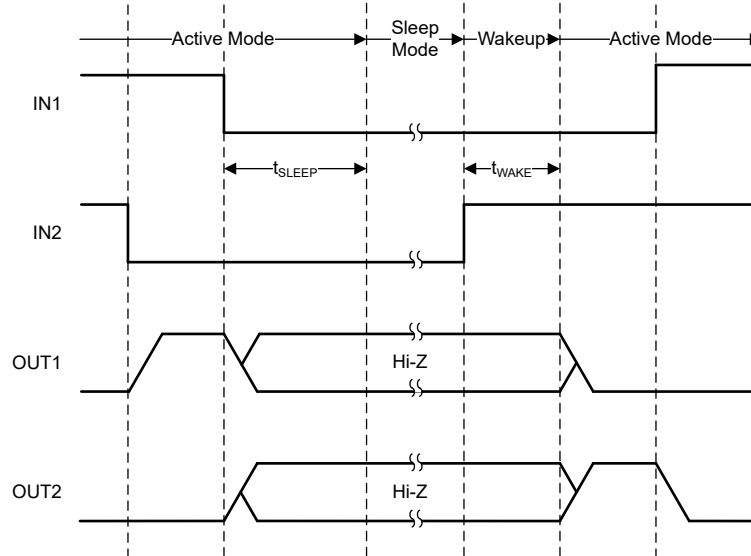
### 8.5.1 Active Mode

After the supply voltage on the VM pin (DSG package) or VCC pin (RTE package) has crossed the rising undervoltage threshold  $V_{UVLO}$ , the INx pins are in a state other than IN1 = 0 & IN2 = 0, and  $t_{WAKE}$  has elapsed, the device enters active mode. In this mode, the full-bridge, charge pump, and internal logic are active and the device is ready to receive inputs.

In the RTE package, when  $V_{VCC} < V_{VM}$ , the DRV8213 draws active current from the VM pin rather than the VCC pin ( $I_{VM}$ ). During this operating condition,  $I_{VCC}$  is typically less than 500 nA. When  $V_{VCC} > V_{VM}$ , the device draws active current from the VCC pin, and the VM pin will only draw current required by the load. When  $V_{VCC} = V_{VM}$ , the active current may be drawn from either supply pin. The active current is typically less than 1.9 mA.

### 8.5.2 Low-Power Sleep Mode

When the IN1 and IN2 pins are both low for time  $t_{SLEEP}$ , the DRV8213 device enters a low-power sleep mode. In sleep mode, the outputs remain High-Z and the device draws minimal current from the supply pin ( $I_{VMQ}$  or  $I_{VCCQ}$ ). After any of the input pins are set high for longer than the duration of  $t_{WAKE}$ , the device becomes fully operational. Figure 8-13 shows an example timing diagram for entering and leaving sleep mode.



**Figure 8-13. Sleep Mode Entry and Wakeup Timing Diagram**

### 8.5.3 Fault Mode

The DRV8213 device enters fault mode when it encounters a fault condition. This protects the device and the load on the outputs. [Table 8-9](#) describes the device behavior in the fault mode which depends on the fault condition. The device will leave the fault mode and re-enter the active mode when the system meets the recovery condition.

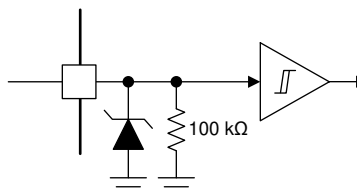
**Table 8-9. Fault Conditions Summary**

FAULT	FAULT CONDITION	ERROR REPORT	FULL-BRIDGE	INTERNAL CIRCUITS	RECOVERY CONDITION
VM undervoltage (UVLO), DSG	$V_{VM} < V_{UVLO\_VM}$ Falling	nFAULT	Disabled	Disabled	$V_{VM} > V_{UVLO\_VM}$ Rising
VCC undervoltage (UVLO), RTE	$V_{VCC} < V_{UVLO\_VCC}$ Falling	nFAULT	Disabled	Disabled	$V_{VCC} > V_{UVLO\_VCC}$ Rising
Overcurrent (OCP)	$I_{OUT} > I_{OCP}$	nFAULT	Disabled	Operating	$I_{OUT} < I_{OCP}$
Thermal Shutdown (TSD)	$T_J > T_{TSD}$	nFAULT	Disabled	Operating	$T_J < T_{TSD} - T_{HYS}$

## 8.6 Pin Diagrams

### 8.6.1 Logic-Level Inputs

[Figure 8-14](#) shows the input structure for the logic-level input pins IN1 and IN2.

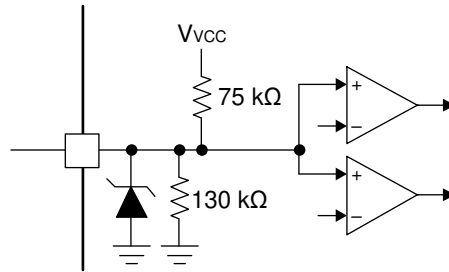


**Figure 8-14. Logic-level input**

### 8.6.2 Tri-Level Input

[Figure 8-15](#) shows the input structure for the tri-level input pins, GAINSEL, IMODE and SMODE.





**Figure 8-15. Tri-level input**

## 9 Application and Implementation

### Note

Information in the following applications sections is not part of the TI component specification, and TI does not warrant its accuracy or completeness. TI's customers are responsible for determining suitability of components for their purposes. Customers should validate and test their design implementation to confirm system functionality.

### 9.1 Application Information

The DRV8213 is intended to drive one brushed DC motor.

### 9.2 Typical Application

#### 9.2.1 Brushed DC Motor

A typical application for the DRV8213 is to drive a brushed DC motor using the full-bridge outputs. [Figure 9-1](#) shows an example schematic using the DSG package for driving a motor and controlling the driver from a microcontroller (MCU). [Figure 9-2](#) shows a schematic example using the RTE package with stall detection disabled. The resistor on the IPROPI pin can provide a voltage signal to the microcontroller analog-to-digital converter (ADC).

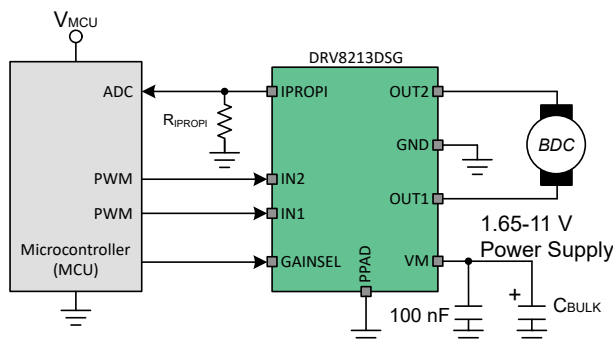


Figure 9-1. Typical Connections for DSG variant

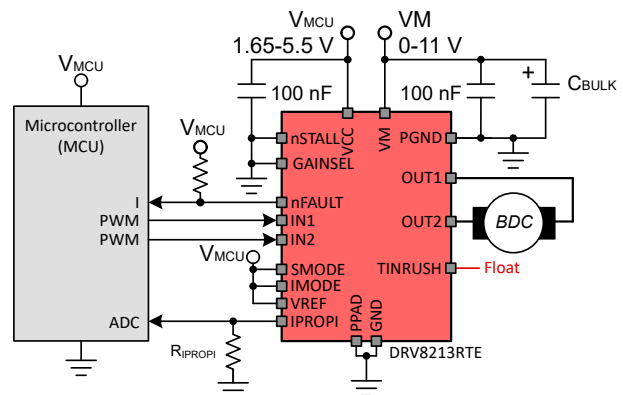


Figure 9-2. Typical Connections for RTE variant with stall detection disabled

#### 9.2.1.1 Design Requirements

[Table 9-1](#) lists example design parameters.

Table 9-1. Design Parameters

DESIGN PARAMETER	REFERENCE	EXAMPLE VALUE
Motor voltage	$V_{VM}$	8 V
Average motor current	$I_{AVG}$	0.8 A
Motor inrush (startup) current	$I_{INRUSH}$	2.1 A
Motor stall current	$I_{STALL}$	2.1 A
Motor current trip point	$I_{TRIP}$	1.9 A
VREF voltage	VREF	3.3 V
IPROPI resistance	$R_{IPROPI}$	8.45 k $\Omega$
PWM frequency	$f_{PWM}$	20 kHz

## 9.2.1.2 Detailed Design Procedure

### 9.2.1.2.1 Motor Voltage

The motor voltage to use depends on the ratings of the motor selected and the desired RPM. A higher voltage spins a brushed DC motor faster with the same PWM duty cycle applied to the power FETs. A higher voltage also increases the rate of current change through the inductive motor windings.

### 9.2.1.2.2 Motor Current

Motors experience large currents at low speed, initial startup, and stalled rotor conditions. The large current at motor startup is sometimes called inrush current. The current regulation feature in the DRV8213 can help to limit these large currents. Alternatively, the microcontroller may limit the inrush current by ramping the PWM duty cycle during the startup time.

### 9.2.1.3 Stall Detection

Some applications require stall detection to notify the microcontroller of a locked-rotor/stall condition. A stall could be caused by one of two things: unintended mechanical blockage or the load reaching an end-stop in a constrained travel path. The DRV8213 supports two methods for determining a stall conditions: hardware stall detection and software stall detection. The RTE package supports hardware stall detection by providing additional pins to configure the response of the device to a stall condition as shown in Figure 9-3. Both DSG and RTE packages support software stall detection by providing the IPROPI analog current sense feedback to the ADC of a microcontroller as shown in Figure 9-1 and Figure 9-2.

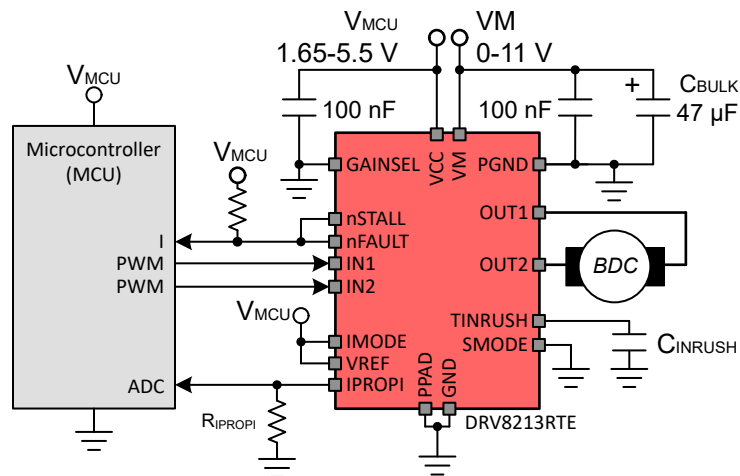


Figure 9-3. Typical Connections for RTE variant with stall detection enabled

### 9.2.1.3.1 Detailed Design Procedure

#### 9.2.1.3.1.1 Hardware Stall Detection Application Description

The principle of this stall detection scheme relies on the fact that motor current increases during stall conditions as shown in Figure 9-5. The DRV8213 compares the voltage on the IPROPI pin to the voltage on the VREF pin to determine whether a stall condition has occurred. The capacitor on the TINRUSH pin sets the timing,  $t_{INRUSH}$ , so the DRV8213 ignores the inrush current at motor startup. The SMODE pin configures how the DRV8213 responds to a stall condition. The IMODE pin configures whether the device regulates current during inrush and stall currents. When a stall condition occurs, nSTALL pulls low to indicate the stall event to the microcontroller. Section 8.4.3 provides full details for configuring the stall detection feature.

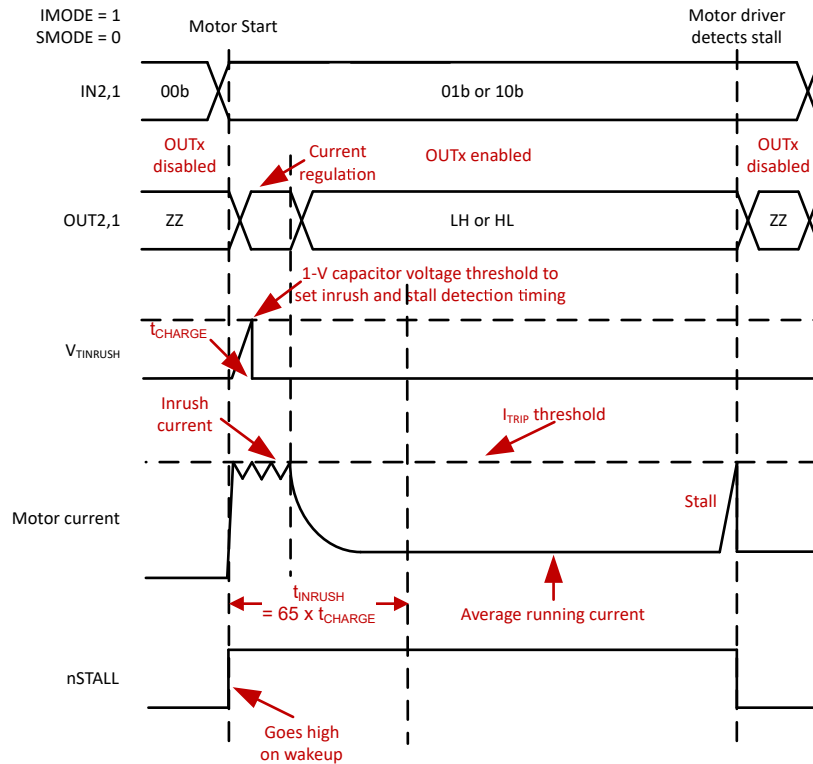


Figure 9-4. Example timing diagram for hardware stall detection

Table 9-2 summarizes stall detection configuration.

Table 9-2. Summary table for hardware stall detection pin configuration

nSTALL	TINRUSH	S.MODE	Description
GND	Z	X	Stall detection disabled. Float TINRUSH. If IMODE = Z, current regulation occurs at all times when $V_{IPROPI} \geq V_{VREF}$ .
Pull-up resistor to VCC	GND	X	TI does not recommend this configuration. $t_{INRUSH}$ corresponds to approximately 6.7s. Device continuously sources 10 uA out of TINRUSH pin into GND. If IMODE = Z, current regulation occurs when $V_{IPROPI} \geq V_{VREF}$ .
	Capacitor to GND	0	Latched disable with indication: the OUTx pins disable and the nSTALL pin pulls low after $t_{INRUSH}$ when $V_{IPROPI} \geq V_{VREF}$ .
		1 / Z	Indication only: the OUTx pins remain active and the nSTALL pin pulls low after $t_{INRUSH}$ when $V_{IPROPI} \geq V_{VREF}$ .
	Z	X	TI does not recommend this configuration. Floating TINRUSH pin effectively sets $t_{INRUSH} = 0$ seconds. The device responds according to the settings of S.MODE and IMODE at all times when $V_{IPROPI} \geq V_{VREF}$ .
VCC	VCC	X	TI does not recommend this configuration. Tying TINRUSH to a voltage higher than 1 V effectively sets $t_{INRUSH} = 0$ seconds. The device draws excessive current from the voltage source due to the TINRUSH discharge path being on.

### 9.2.1.3.1.1 Hardware Stall Detection Timing

Large inrush current occurs during motor start up because motor speed is low. As the motor accelerates, the motor current drops to an average level because the back electromotive force (EMF) in the motor increases with speed. The inrush current should not be mistaken for a stall condition, so the DRV8213 integrates a timing circuit in the RTE package variant to ignore the inrush current during the startup time,  $t_{INRUSH}$ . The timing circuit is configured using a capacitor,  $C_{INRUSH}$ , on the TINRUSH pin. Section 8.4.3 describes the overall details for using the stall detection feature.

When designing for the  $t_{\text{INRUSH}}$  time, it is important to include enough margin to account for tolerances and variation in the DRV8213 and the system overall. Equation 4 defines the minimum  $t_{\text{INRUSH}}$  time,  $t_{\text{INRUSH\_min}}$ . The timing  $t_{\text{INRUSH\_motor}}$  should be determined experimentally because it depends on motor parameters, supply voltage, temperature, and mechanical load response times. The  $\epsilon_{\text{TINRUSH}}$  term accounts for tolerances in the TINRUSH timing circuit and the  $C_{\text{INRUSH}}$  capacitor.

$$t_{\text{INRUSH\_min}} = t_{\text{INRUSH\_motor}} \times (1 + \epsilon_{\text{TINRUSH}}) \quad (4)$$

Equation 5 shows the expression for finding  $\epsilon_{\text{TINRUSH}}$ . The tolerance of the 1-V reference on the TINRUSH pin is  $\epsilon_{V_{\text{TINRUSH\_trip}}}$ . This tolerance is 3%, as defined by the minimum and maximum specifications for  $V_{\text{TINRUSH\_trip}}$  in the Electrical Characteristics table. The tolerance of the 10- $\mu\text{A}$  current source on the TINRUSH pin is  $\epsilon_{I_{\text{TINRUSH}}}$ . This tolerance is 20%, as defined by the minimum and maximum specifications for  $I_{\text{TINRUSH}}$  in the Electrical Characteristics table. The tolerance of the  $C_{\text{INRUSH}}$  capacitor is  $\epsilon_{C_{\text{INRUSH}}}$ . This is a percentage defined by the tolerance of the selected  $C_{\text{INRUSH}}$  capacitor.

$$\epsilon_{\text{TINRUSH}} = \sqrt{\epsilon_{V_{\text{TINRUSH\_trip}}}^2 + \epsilon_{I_{\text{TINRUSH}}}^2 + \epsilon_{C_{\text{INRUSH}}}^2} \quad (5)$$

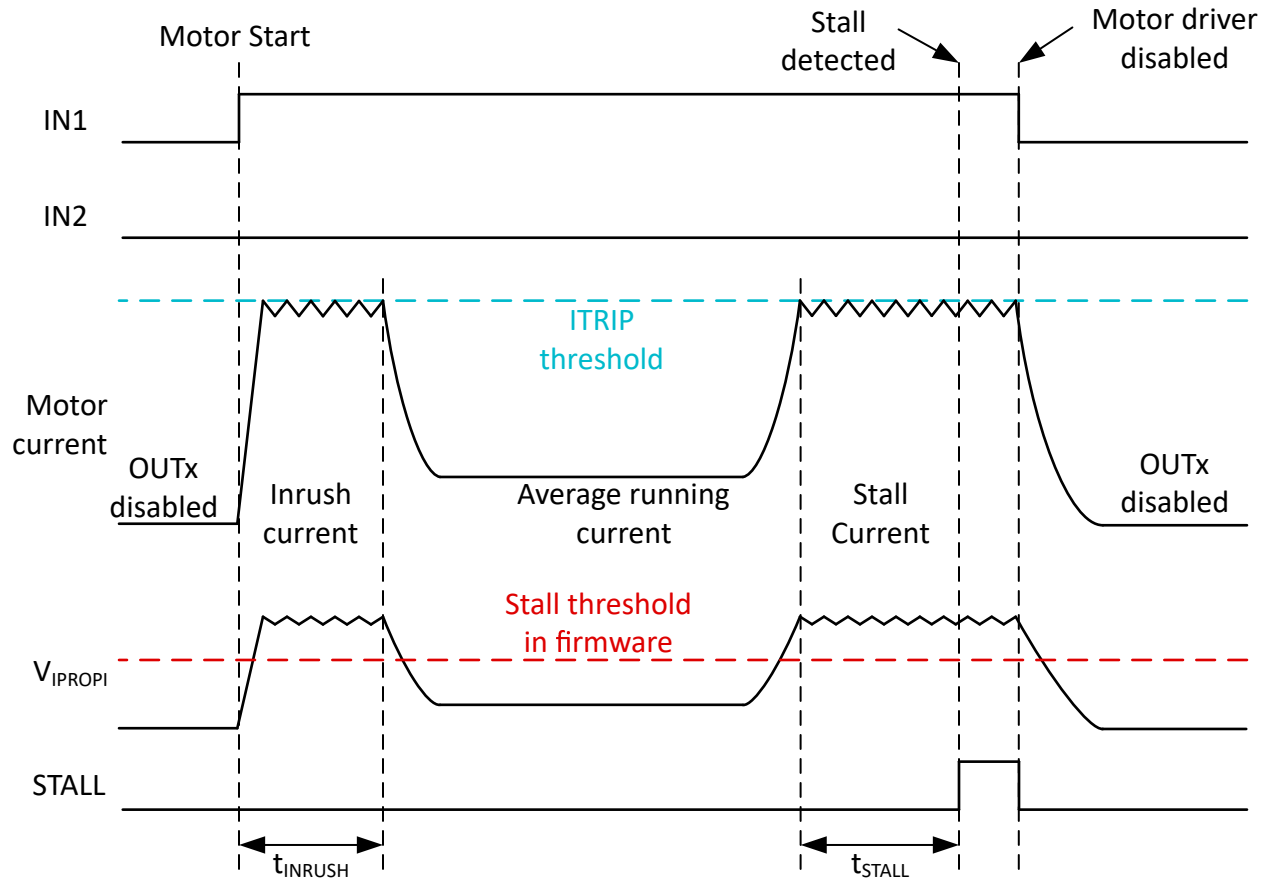
For example, assume  $t_{\text{INRUSH\_motor}} = 100$  ms and a capacitor with 1% tolerance will be used for  $C_{\text{INRUSH}}$ . In this case, it can be calculated that the  $C_{\text{INRUSH}}$  capacitor should be larger than 18.5 nF, so a 22 nF capacitor will be sufficient in this application.

#### 9.2.1.3.1.2 Hardware Stall Threshold Selection

The voltage on the VREF pin selects  $I_{\text{TRIP}}$  threshold which sets the current level for stall detection and current regulation. This threshold should be chosen such that  $I_{\text{TRIP}}$  is less than the stall current of the motor when current regulation is not used. It should also be set low enough to account for variation in the stall current due to changes in the motor supply voltage,  $V_{\text{VM}}$ , and temperature. Section 8.4.2.2 and Section 8.4.3 provide more details for configuring the voltage on the VREF pin.

#### 9.2.1.3.1.2 Software Stall Detection Application Description

The principle of this stall detection scheme relies on the fact that motor current increases during stall conditions as shown in Figure 9-5. To implement stall detection, the microcontroller reads the voltage on the IPROPI pin using an ADC and compares it to a stall threshold set in firmware. Alternatively, a comparator peripheral may be used to set this threshold.



**Figure 9-5. Motor Current Profile with STALL Signal**

#### 9.2.1.3.1.2.1 Software Stall Detection Timing

The microcontroller needs to decide whether or not the IPROPI signal indicates a motor stall. Large inrush current occurs during motor start up because motor speed is low. As the motor accelerates, the motor current drops to an average level because the back electromotive force (EMF) in the motor increases with speed. Do not mistake the inrush current for a stall condition. One way to do this is for the microcontroller to ignore the IPROPI signal above the firmware stall threshold for the duration of the inrush current,  $t_{INRUSH}$ , at startup. The  $t_{INRUSH}$  timing is determined experimentally using the motor parameters, supply voltage, and mechanical load response times.

When a stall condition occurs, the motor current increases from the average running current level because the back EMF is now 0 V. In some cases, it may be desirable to drive at the stall current for some time in case the motor can clear the blockage on its own. This might be useful for an unintended stall or high-torque condition on the motor. In this case, the system designer can choose a long stall detection time,  $t_{STALL}$ , before the microcontroller decides to take action. In other cases, like end-stop detection, a faster response might be desired to reduce power or minimize strong motor torque on the gears or end-stop. This corresponds to setting a shorter  $t_{STALL}$  time in the microcontroller.

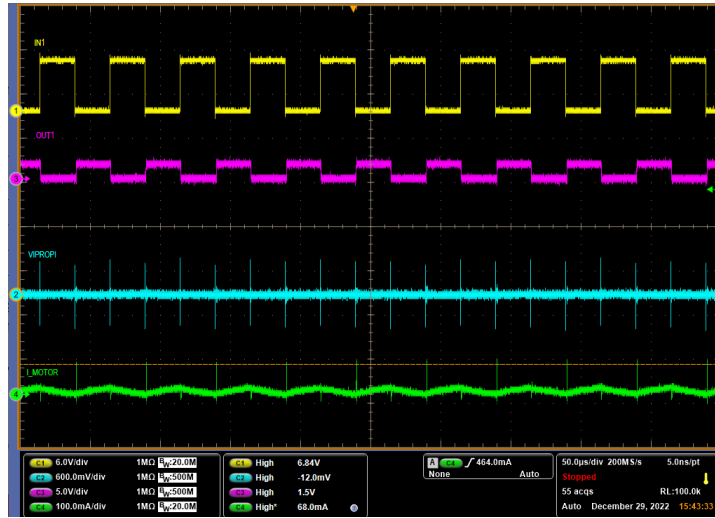
Figure 9-5 illustrates the  $t_{INRUSH}$  and  $t_{STALL}$  timings and how they relate to the motor current waveform.

#### 9.2.1.3.1.2.2 Software Stall Threshold Selection

The stall detection threshold in firmware should be chosen at a current level between the maximum stall current and the average running current of the motor as shown in Figure 9-5.

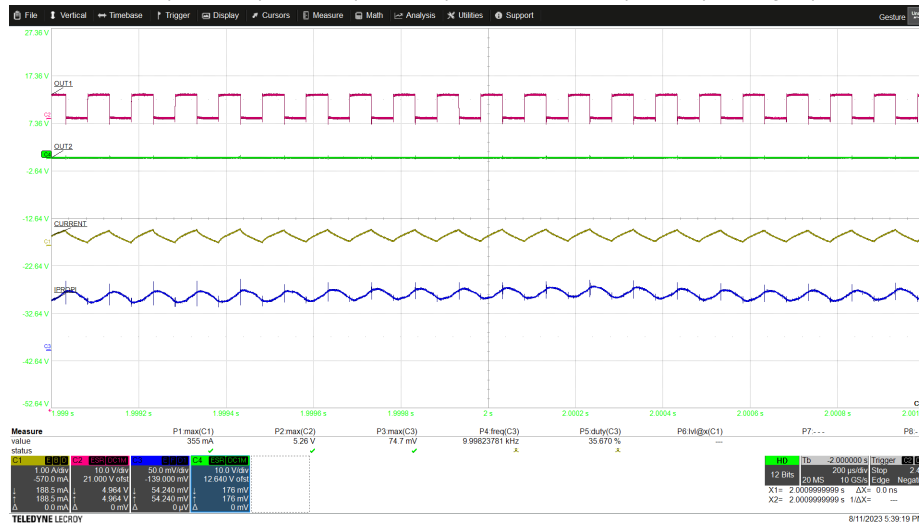
### 9.2.1.4 Application Curves

Traces from top to bottom: IN1 (6 V/div), OUT2 (5 V/div),  $V_{IPROPI}$  (600 mV/div), Motor Current (100 mA/div)



**Figure 9-6. PWM Operation at VM = 1.65 V**

Traces from top to bottom: OUT1 (10 V/div), OUT2 (10 V/div), Motor Current (1 A/div),  $V_{IPROPI}$  (50 mV/div)



**Figure 9-7. PWM Operation at VM = 5 V**

Traces from top to bottom: IN1 (7 V/div), OUT2 (6 V/div), Motor Current (200 mA/div),  $V_{IPROPI}$  (2 V/div)

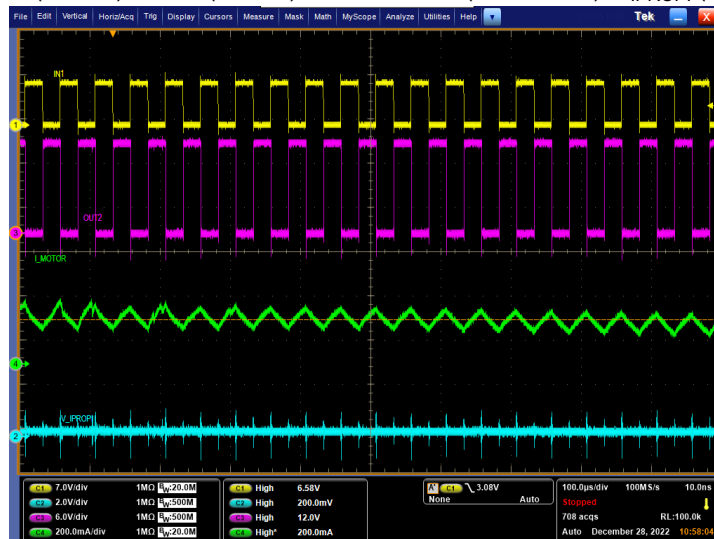


Figure 9-8. PWM Operation at  $V_M = 11\text{ V}$

Traces from top to bottom: nSTALL (4 V/div), TINRUSH (1 V/div), OUT2 (5 V/div), Motor Current (600 mA/div)

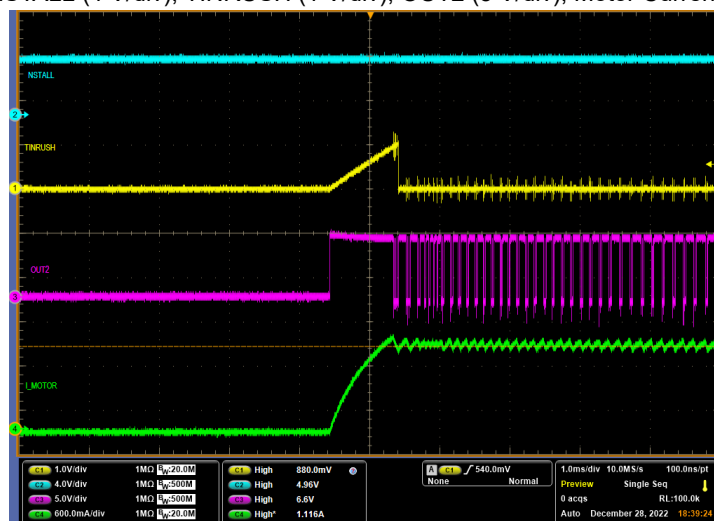


Figure 9-9. Stall Detection with  $IMODE = \text{Hi-Z}$ ,  $SMODE = 1$

### 9.2.1.5 Thermal Performance

The datasheet-specified junction-to-ambient thermal resistance,  $R_{\theta JA}$ , is primarily useful for comparing various drivers or approximating thermal performance. However, the actual system performance may be better or worse than this value depending on PCB stackup, routing, number of vias, and copper area around the thermal pad. The length of time the driver drives a particular current will also impact power dissipation and thermal performance. This section considers how to design for steady-state and transient thermal conditions.

The data in this section was simulated using the following criteria:

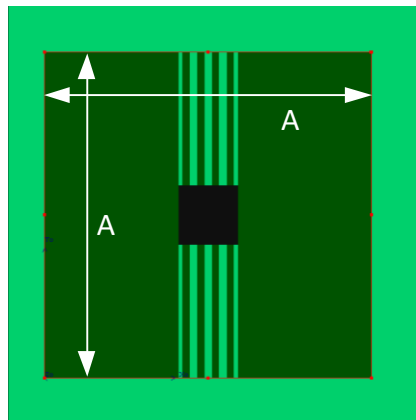
#### WSON (DSG package)

- 2-layer PCB (size 114.3 x 76.2 x 1.6 mm), standard FR4, 1-oz (35 mm copper thickness) or 2-oz copper thickness. Thermal vias are only present under the thermal pad (2 vias, 1.2mm spacing, 0.3 mm diameter, 0.025 mm Cu plating).
  - Top layer: DRV8213 WSON package footprint and copper plane heatsink. Top layer copper area is varied in simulation.



- Bottom layer: ground plane thermally connected through vias under the thermal pad for DRV8213. Bottom layer copper area varies with top copper area.
- 4-layer PCB (size 114.3 x 76.2 x 1.6 mm), standard FR4. Outer planes are 1-oz (35 mm copper thickness) or 2-oz copper thickness. Inner planes are kept at 1-oz. Thermal vias are only present under the thermal pad (2 vias, 1.2mm spacing, 0.3 mm diameter, 0.025 mm Cu plating).
  - Top layer: DRV8213 WSON package footprint and copper plane heatsink. Top layer copper area is varied in simulation.
  - Mid layer 1: GND plane thermally connected to DRV8213 thermal pad through vias. The area of the ground plane is 74.2 mm x 74.2 mm.
  - Mid layer 2: power plane, no thermal connection. The area of the power plane is 74.2 mm x 74.2 mm.
  - Bottom layer: ground plane thermally connected through via stitching from the TOP and internal GND planes. Bottom layer copper area varies with top copper area.

Figure 9-10 shows an example of the simulated board for the DSG package. Table 9-3 shows the dimensions of the board that were varied for each simulation.



**Figure 9-10. WSON PCB model top layer**

**Table 9-3. Dimension A for 8-pin DSG package**

Cu area (mm <sup>2</sup> )	Dimension A (mm)
2	15.11
4	20.98
8	29.27
16	40.99

### WQFN (RTE package)

- 2-layer PCB (size 114.3 x 76.2 x 1.6 mm), standard FR4, 1-oz (35 mm copper thickness) or 2-oz copper thickness. Thermal vias are only present under the package footprint (5 vias, 1 mm pitch, 0.2 mm diameter, 0.025 mm Cu plating).
  - Top layer: WQFN package footprint and traces.
  - Bottom layer: ground plane thermally connected through vias under the package footprint. Bottom layer copper area is varied in simulation.
- 4-layer PCB (size 114.3 x 76.2 x 1.6 mm), standard FR4. Outer planes are 1-oz (35 mm copper thickness) or 2-oz copper thickness. Inner planes are kept at 1-oz. Thermal vias are only present under the package footprint (5 vias, 1 mm pitch, 0.2 mm diameter, 0.025 mm Cu plating).
  - Top layer: WQFN package footprint and traces.
  - Mid layer 1: GND plane thermally connected under package footprint through vias. The area of the ground plane is 74.2 mm x 74.2 mm.
  - Mid layer 2: power plane, no thermal connection. The area of the power plane is 74.2 mm x 74.2 mm.

- Bottom layer: signal layer with small copper pad underneath the driver and thermally connected through via stitching from the TOP and internal GND plane. Bottom layer thermal pad is the same size as the package (3 mm x 3 mm). Bottom pad size remains constant.

Figure 9-11 shows an example of the simulated board for the WQFN package. Table 9-4 shows the dimensions of the board that were varied for each simulation.

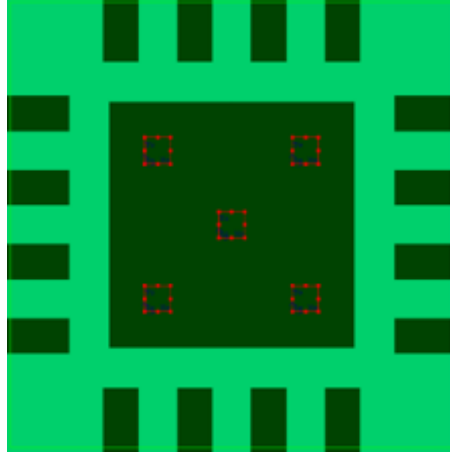


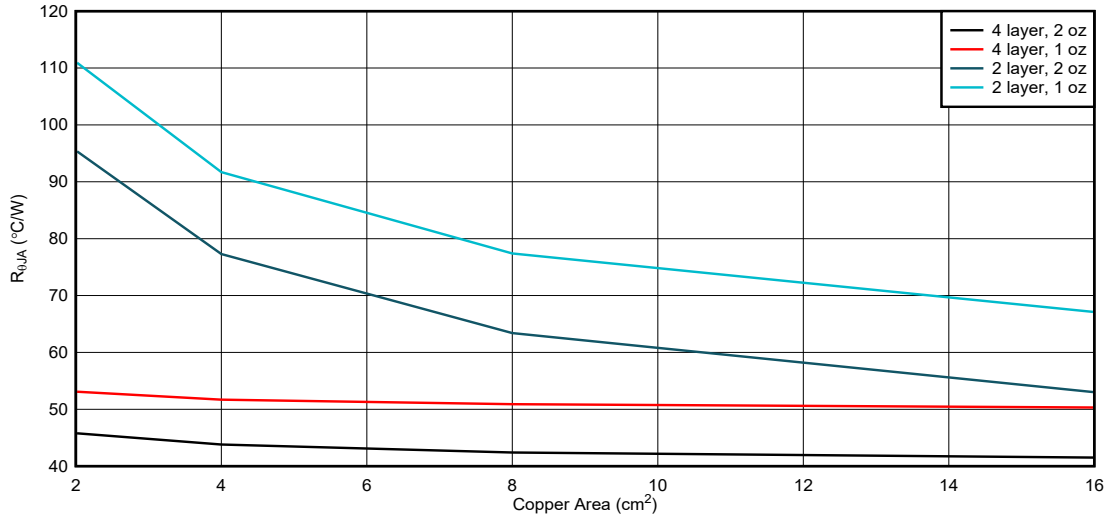
Figure 9-11. WQFN PCB model top layer

Table 9-4. Dimension A for 16-pin RTE package

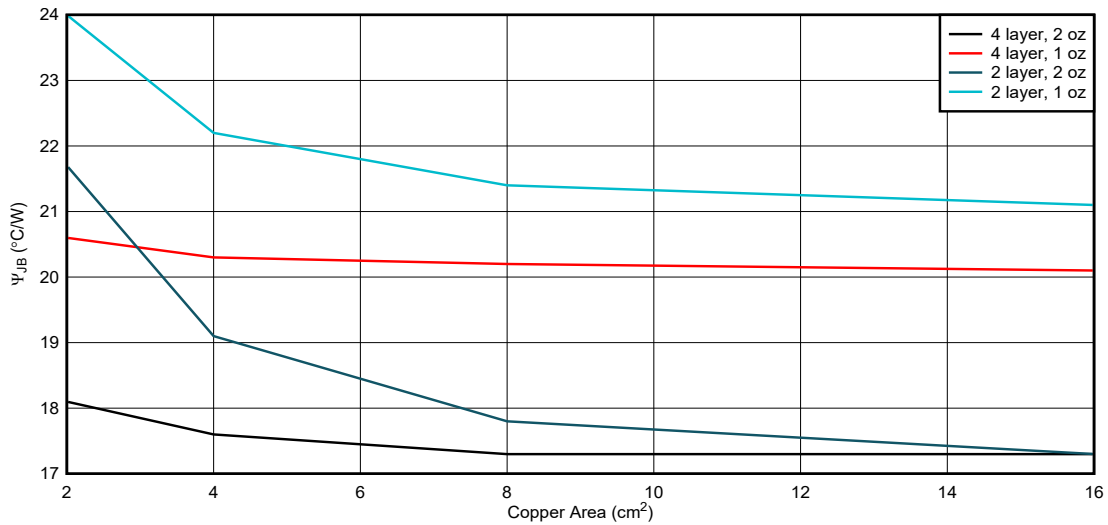
Cu area (cm <sup>2</sup> )	Dimension A (mm)
2	14.14
4	20.00
8	28.28
16	40.00

#### 9.2.1.5.1 Steady-State Thermal Performance

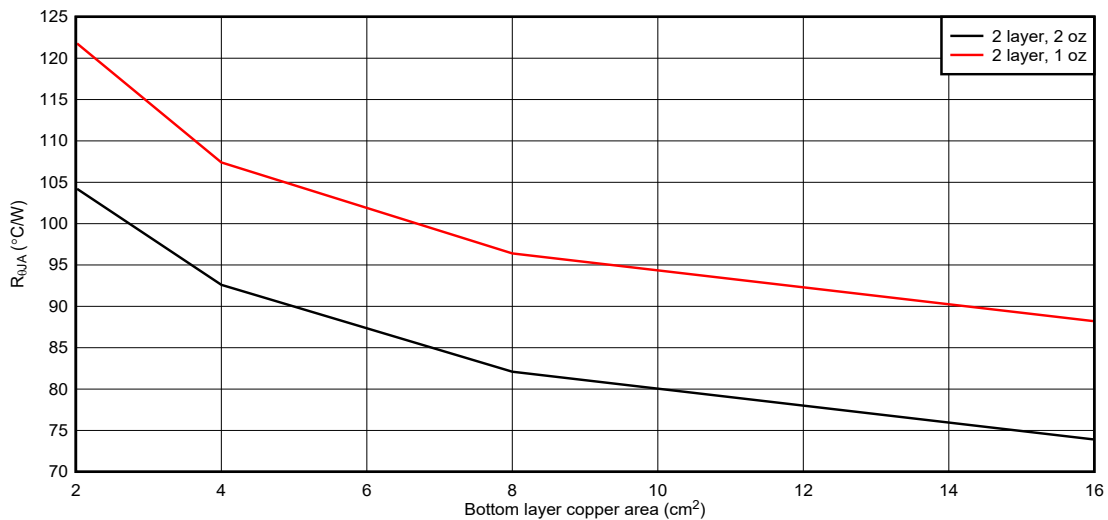
"Steady-state" conditions assume that the motor driver operates with a constant RMS current over a long period of time. The figures in this section show how  $R_{\theta JA}$  and  $\Psi_{JB}$  (junction-to-board characterization parameter) change depending on copper area, copper thickness, and number of layers of the PCB. More copper area, more layers, and thicker copper planes decrease  $R_{\theta JA}$  and  $\Psi_{JB}$ , which indicate better thermal performance from the PCB layout.



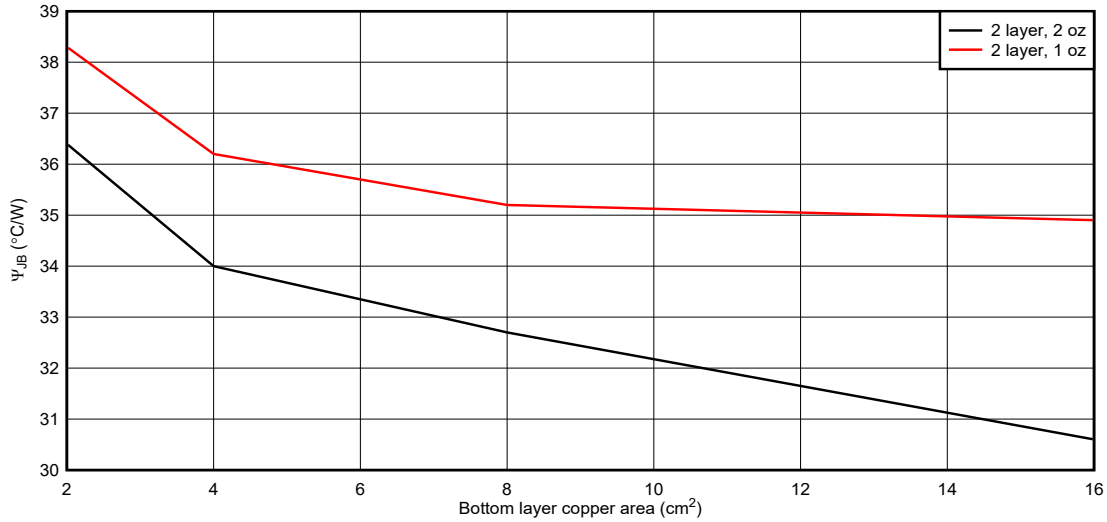
**Figure 9-12. WSON, PCB junction-to-ambient thermal resistance vs copper area**



**Figure 9-13. WSON, junction-to-board characterization parameter vs copper area**



**Figure 9-14. WQFN, PCB junction-to-ambient thermal resistance vs copper area**



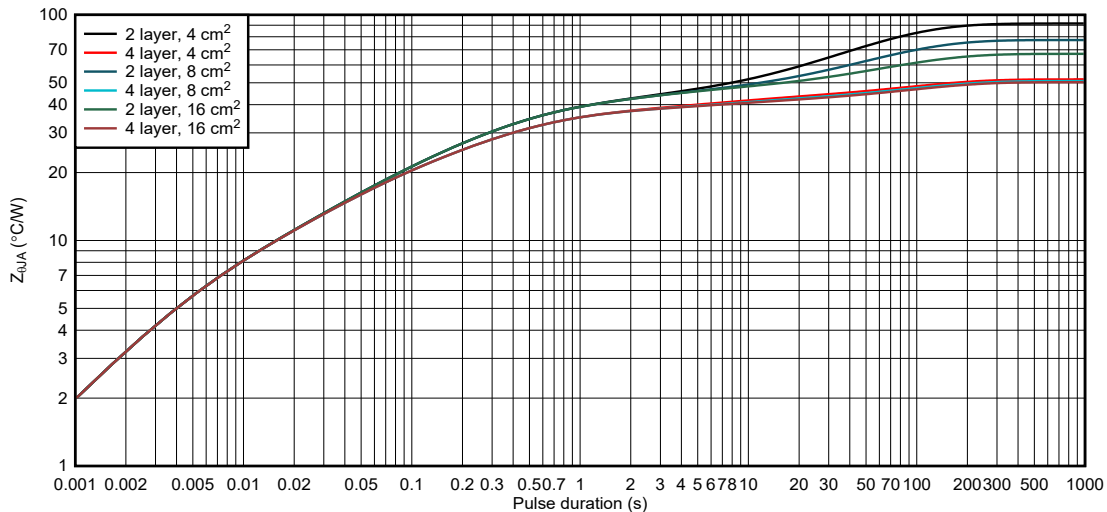
**Figure 9-15. WQFN, junction-to-board characterization parameter vs copper area**

### 9.2.1.5.2 Transient Thermal Performance

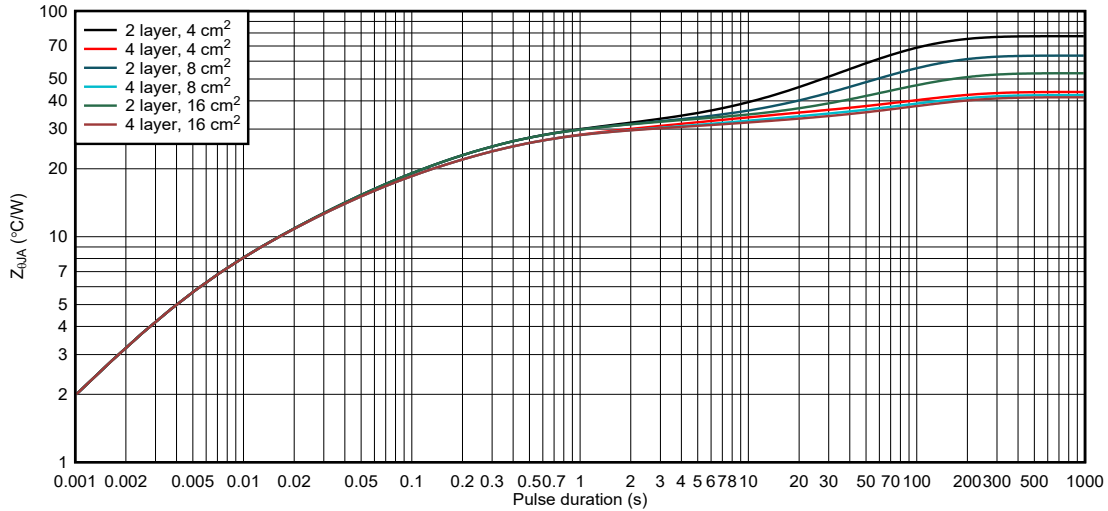
The motor driver may experience different transient driving conditions that cause large currents to flow for a short duration of time. These may include -

- Motor start-up when the rotor is initially stationary.
- Fault conditions when there is a supply or ground short to one of the motor outputs, and the overcurrent protection triggers.
- Briefly energizing a motor or solenoid for a limited time, then de-energizing.

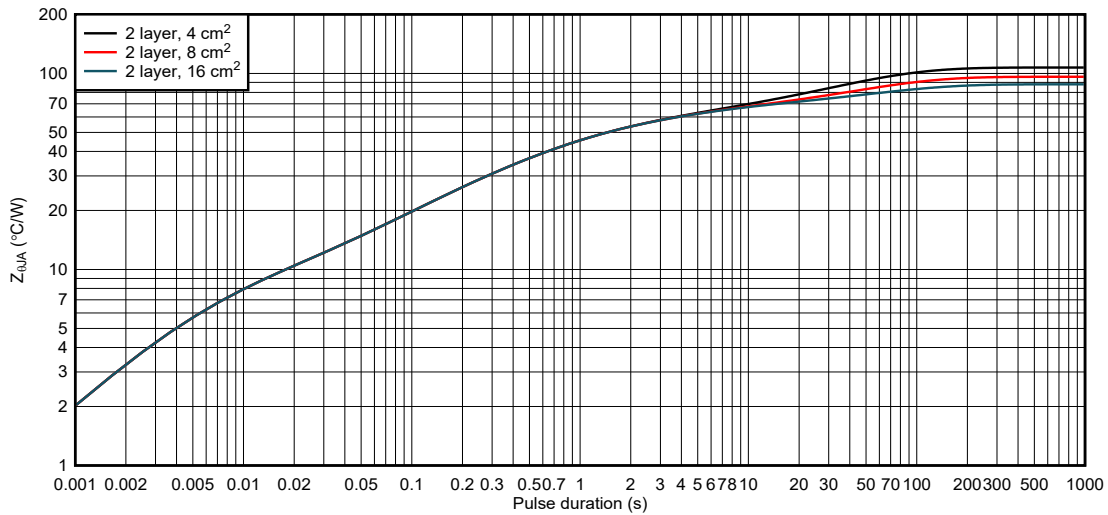
For these transient cases, the duration of drive time is another factor that impacts thermal performance in addition to copper area and thickness. In transient cases, the thermal impedance parameter  $Z_{\theta JA}$  denotes the junction-to-ambient thermal performance. The figures in this section show the simulated thermal impedances for 1-oz and 2-oz copper layouts for the WSON and WQFN packages. These graphs indicate better thermal performance with short current pulses. For short periods of drive time, the device die size and package dominates the thermal performance. For longer drive pulses, board layout has a more significant impact on thermal performance. Both graphs show the curves for thermal impedance split due to number of layers and copper area as the duration of the drive pulse duration increases. Long pulses can be considered steady-state performance.



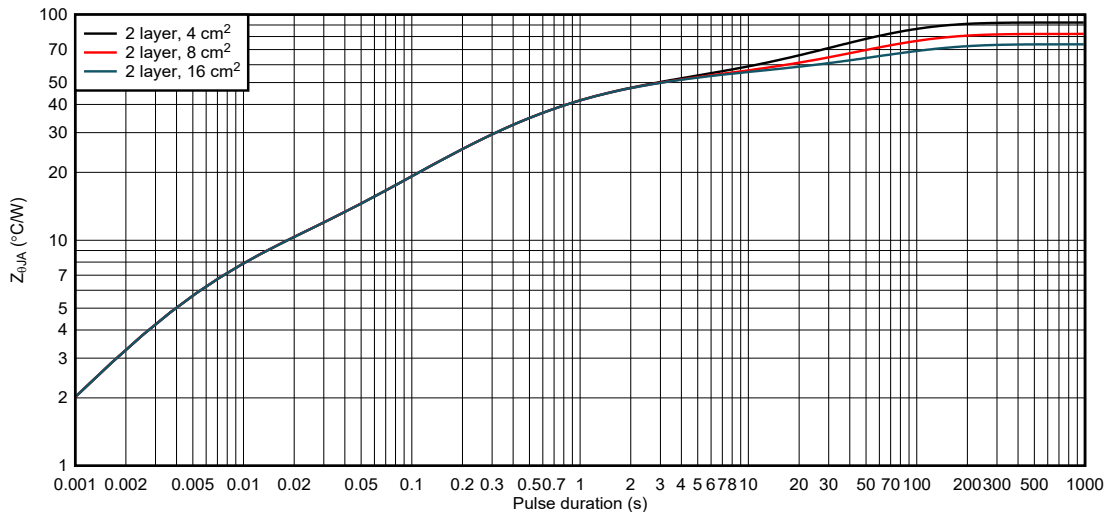
**Figure 9-16. WSON package junction-to-ambient thermal impedance for 1-oz copper layouts**



**Figure 9-17. WSON package junction-to-ambient thermal impedance for 2-oz copper layouts**



**Figure 9-18. WQFN package junction-to-ambient thermal impedance for 1-oz copper layouts**



**Figure 9-19. WQFN package junction-to-ambient thermal impedance for 2-oz copper layouts**

## 10 Power Supply Recommendations

### 10.1 Bulk Capacitance

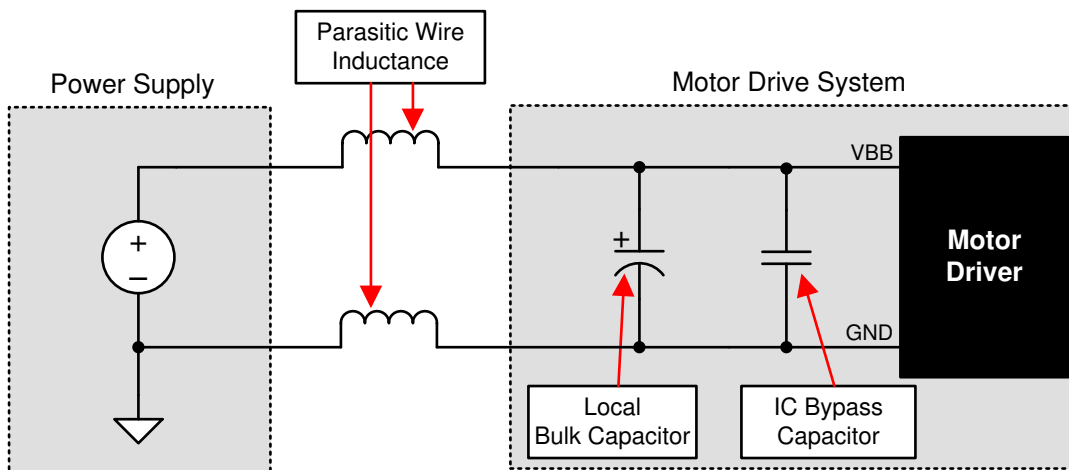
Having appropriate local bulk capacitance is an important factor in motor drive system design. Having more bulk capacitance is generally beneficial, while the disadvantages are increased cost and physical size.

The amount of local capacitance needed depends on a variety of factors, including:

- The highest current required by the motor system
- The capacitance of the power supply and ability to source current
- The amount of parasitic inductance between the power supply and motor system
- The acceptable voltage ripple
- The type of motor used (brushed DC, brushless DC, stepper)
- The motor braking method

The inductance between the power supply and motor drive system limits how the rate current can change from the power supply. If the local bulk capacitance is too small, the system responds to excessive current demands or dumps from the motor with a change in voltage. When adequate bulk capacitance is used, the motor voltage remains stable and high current can be quickly supplied.

The data sheet generally provides a recommended value, but system-level testing is required to determine the appropriate sized bulk capacitor.



**Figure 10-1. Example Setup of Motor Drive System With External Power Supply**

The voltage rating for bulk capacitors should be higher than the operating voltage, to provide margin for cases when the motor transfers energy to the supply.

## 11 Layout

### 11.1 Layout Guidelines

Since the DRV8213 integrates power MOSFETs capable of driving high current, careful attention should be paid to the layout design and external component placement. Some design and layout guidelines are provided below.

- Low ESR ceramic capacitors should be utilized for the VM to GND bypass capacitor. X5R and X7R types are recommended.
- The VM power supply capacitors should be placed as close to the device as possible to minimize the loop inductance.
- The VM power supply bulk capacitor can be of ceramic or electrolytic type, but should also be placed as close as possible to the device to minimize the loop inductance.
- VM, OUT1, OUT2, and GND carry the high current from the power supply to the outputs and back to ground. Thick metal routing should be utilized for these traces as is feasible.
- The device thermal pad should be attached to the PCB top layer ground plane and internal ground plane (when available) through thermal vias to maximize the PCB heat sinking.
- A recommended land pattern for the thermal vias is provided in the package drawing section.
- The copper plane area attached to the thermal pad should be maximized to ensure optimal heat sinking.

## 12 Device and Documentation Support

### 12.1 Documentation Support

#### 12.1.1 Related Documentation

For related documentation, see the following:

- Texas Instruments, [Calculating Motor Driver Power Dissipation](#) application report
- Texas Instruments, [Current Recirculation and Decay Modes](#) application report
- Texas Instruments, [PowerPAD™ Made Easy](#) application report
- Texas Instruments, [PowerPAD™ Thermally Enhanced Package](#) application report
- Texas Instruments, [Understanding Motor Driver Current Ratings](#) application report

#### 12.2 Receiving Notification of Documentation Updates

To receive notification of documentation updates, navigate to the device product folder on ti.com. In the upper right corner, click on *Alert me* to register and receive a weekly digest of any product information that has changed. For change details, review the revision history included in any revised document.

#### 12.3 Community Resources

#### 12.4 Trademarks

All trademarks are the property of their respective owners.

## 13 Mechanical, Packaging, and Orderable Information

The following pages include mechanical, packaging, and orderable information. This information is the most current data available for the designated devices. This data is subject to change without notice and revision of this document. For browser-based versions of this data sheet, refer to the left-hand navigation.



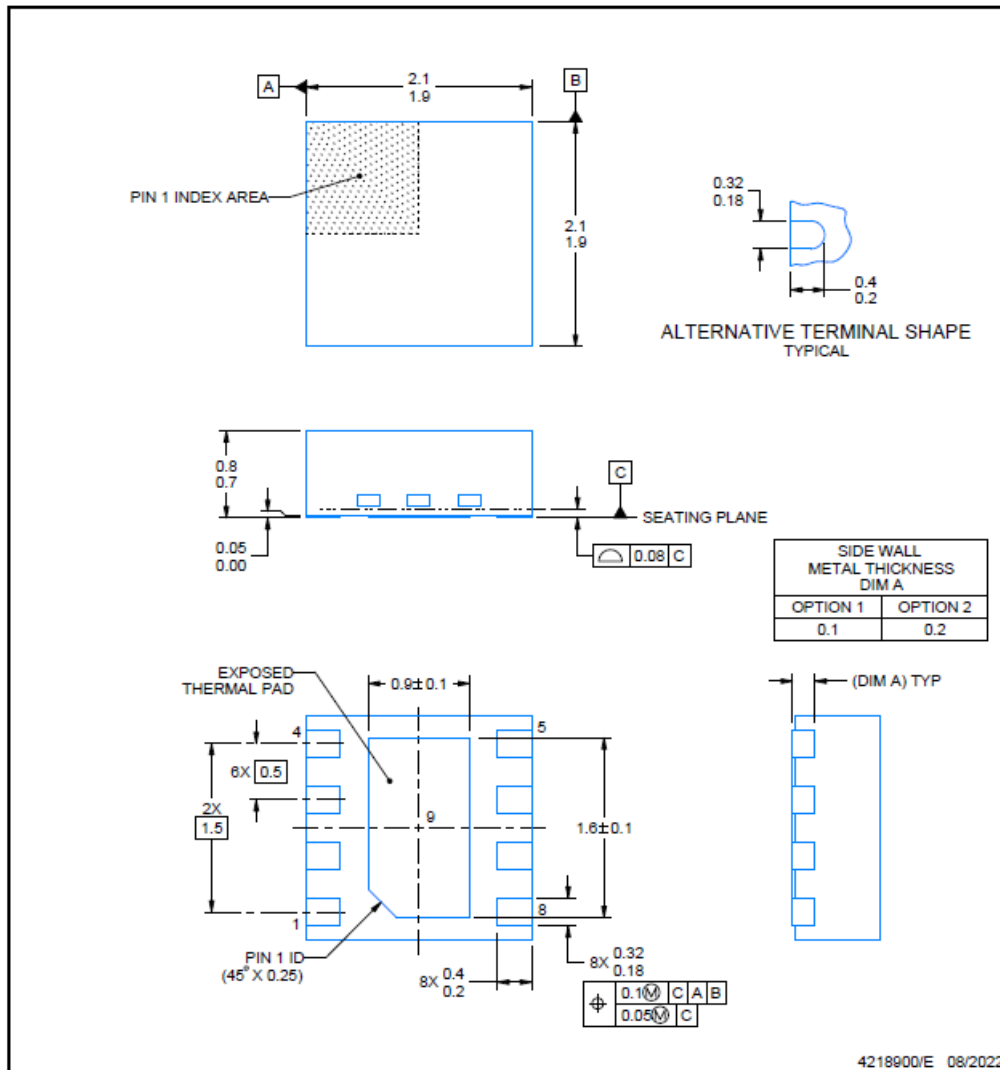


**DSG0008A**

**PACKAGE OUTLINE**

**WSON - 0.8 mm max height**

PLASTIC SMALL OUTLINE - NO LEAD



**NOTES:**

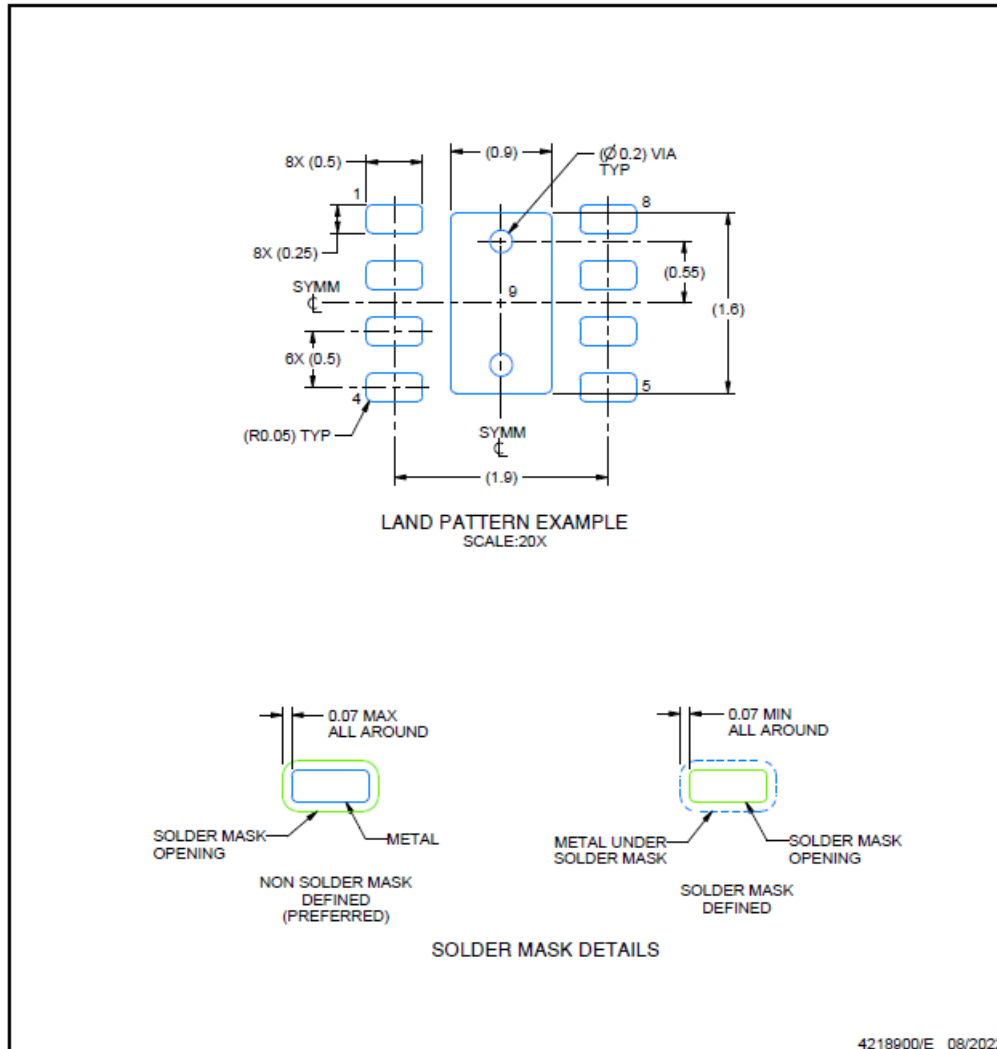
1. All linear dimensions are in millimeters. Any dimensions in parenthesis are for reference only. Dimensioning and tolerancing per ASME Y14.5M.
2. This drawing is subject to change without notice.
3. The package thermal pad must be soldered to the printed circuit board for thermal and mechanical performance.

## EXAMPLE BOARD LAYOUT

DSG0008A

WSON - 0.8 mm max height

PLASTIC SMALL OUTLINE - NO LEAD



NOTES: (continued)

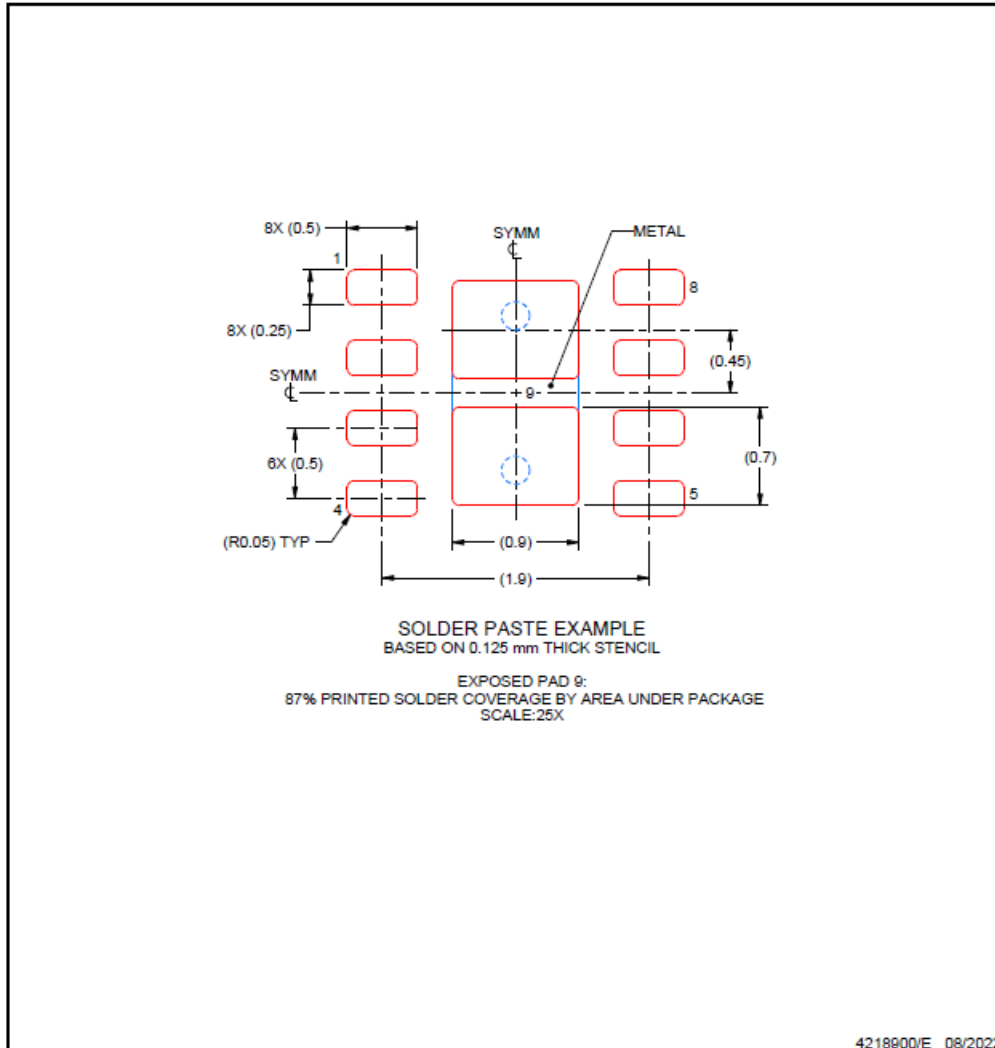
4. This package is designed to be soldered to a thermal pad on the board. For more information, see Texas Instruments literature number SLUA271 ([www.ti.com/lit/slua271](http://www.ti.com/lit/slua271)).
5. Vias are optional depending on application, refer to device data sheet. If any vias are implemented, refer to their locations shown on this view. It is recommended that vias under paste be filled, plugged or tented.

## EXAMPLE STENCIL DESIGN

**DSG0008A**

**WSON - 0.8 mm max height**

PLASTIC SMALL OUTLINE - NO LEAD



NOTES: (continued)

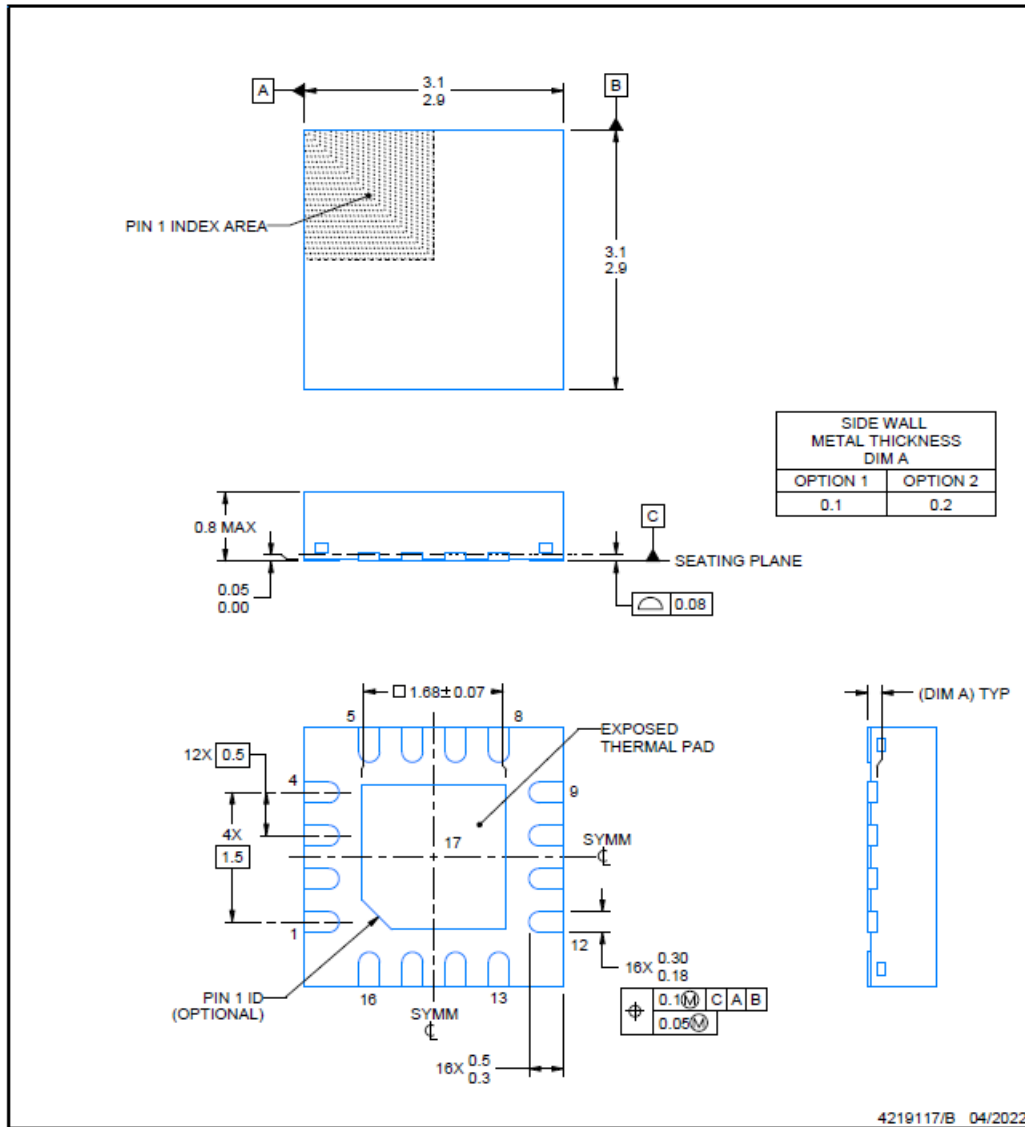
6. Laser cutting apertures with trapezoidal walls and rounded corners may offer better paste release. IPC-7525 may have alternate design recommendations.

**RTE0016C**



**PACKAGE OUTLINE**  
**WQFN - 0.8 mm max height**

PLASTIC QUAD FLATPACK - NO LEAD



**NOTES:**

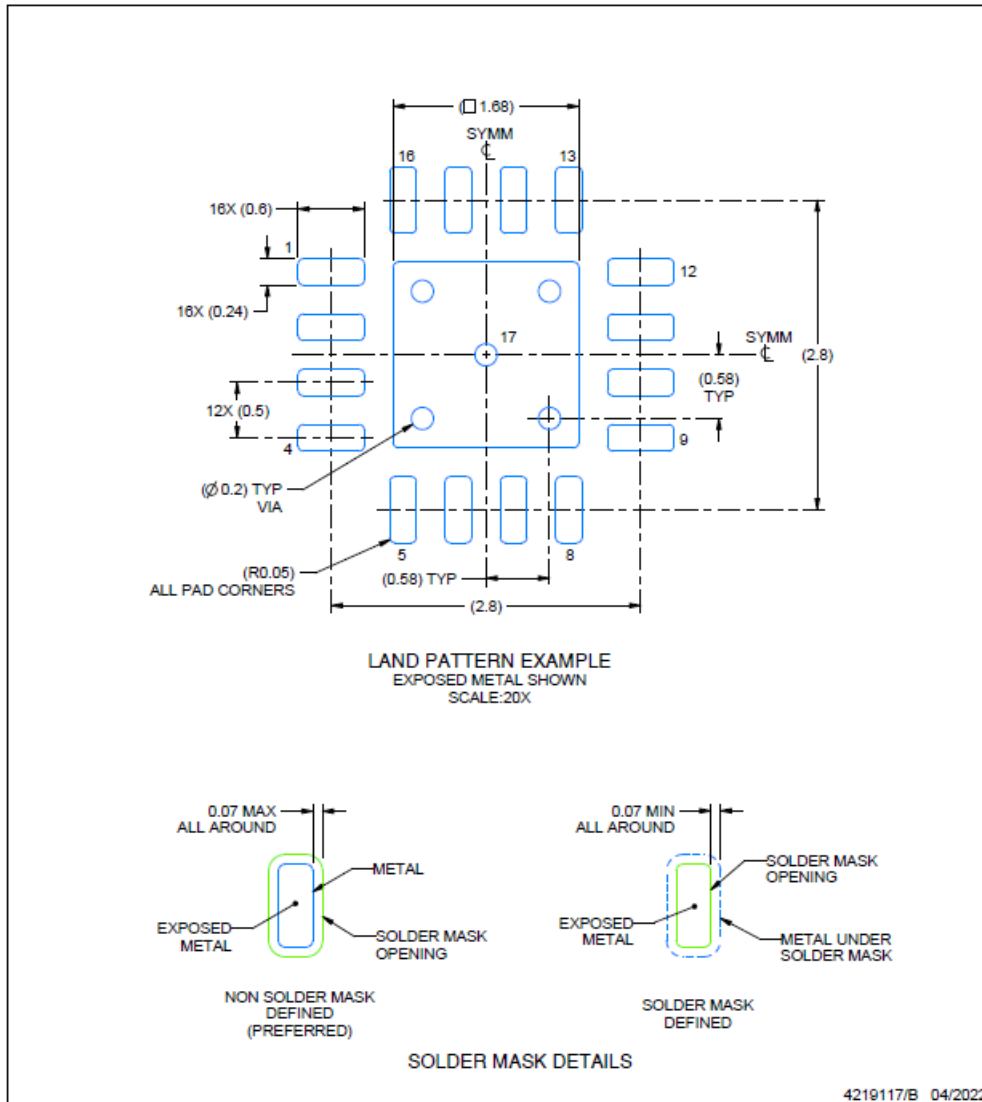
1. All linear dimensions are in millimeters. Any dimensions in parenthesis are for reference only. Dimensioning and tolerancing per ASME Y14.5M.
2. This drawing is subject to change without notice.
3. The package thermal pad must be soldered to the printed circuit board for thermal and mechanical performance.

**EXAMPLE BOARD LAYOUT**

**RTE0016C**

**WQFN - 0.8 mm max height**

PLASTIC QUAD FLATPACK - NO LEAD



NOTES: (continued)

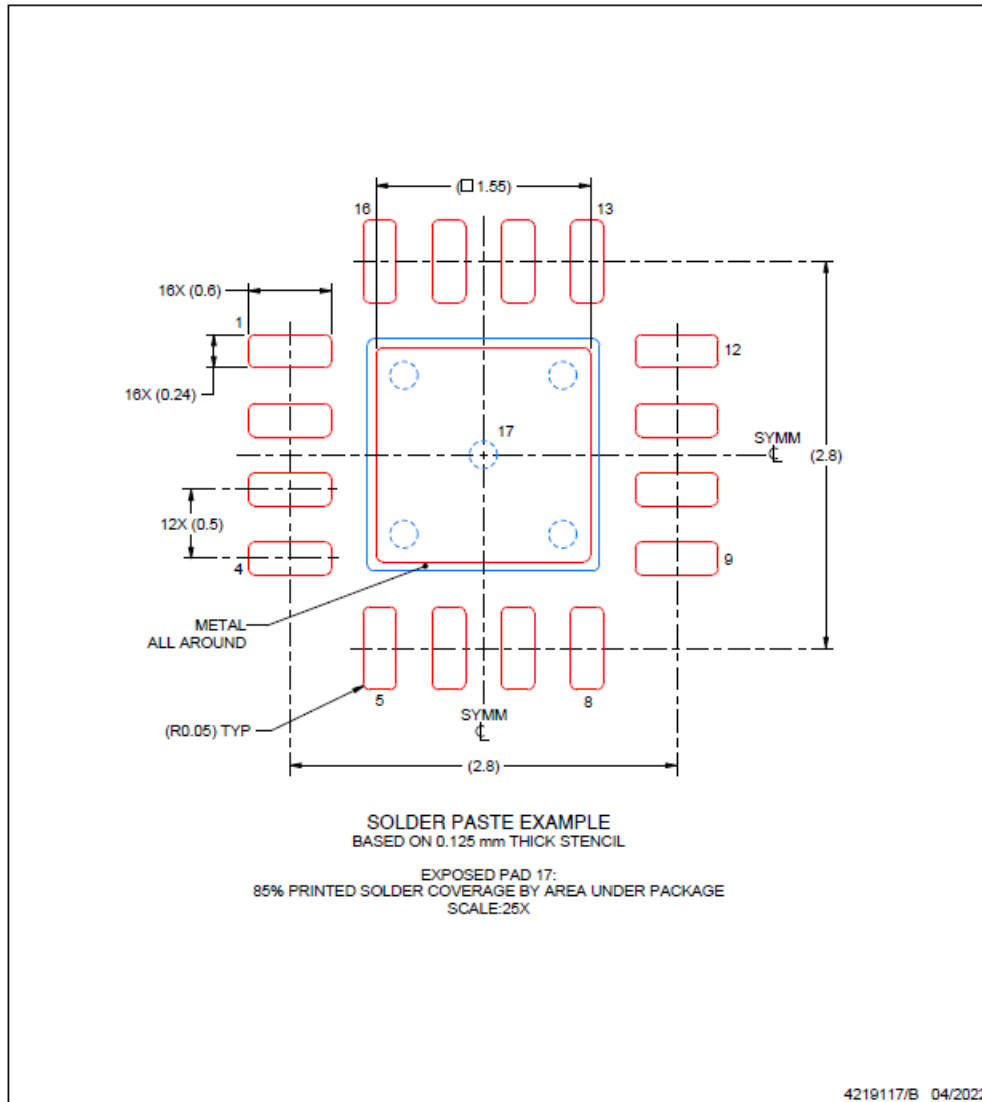
4. This package is designed to be soldered to a thermal pad on the board. For more information, see Texas Instruments literature number SLUA271 ([www.ti.com/lit/slua271](http://www.ti.com/lit/slua271)).
5. Vias are optional depending on application, refer to device data sheet. If any vias are implemented, refer to their locations shown on this view. It is recommended that vias under paste be filled, plugged or tented.

### EXAMPLE STENCIL DESIGN

**RTE0016C**

**WQFN - 0.8 mm max height**

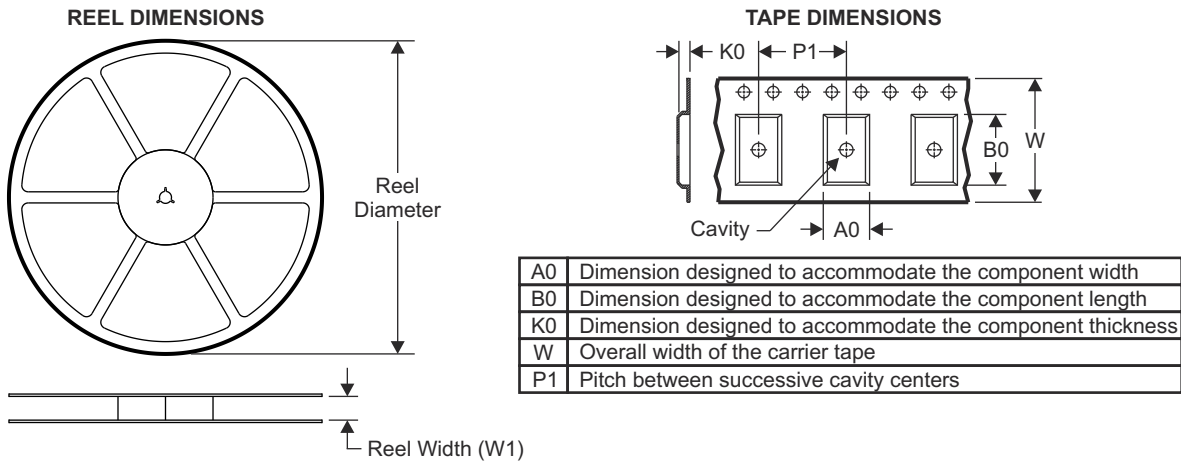
PLASTIC QUAD FLATPACK - NO LEAD



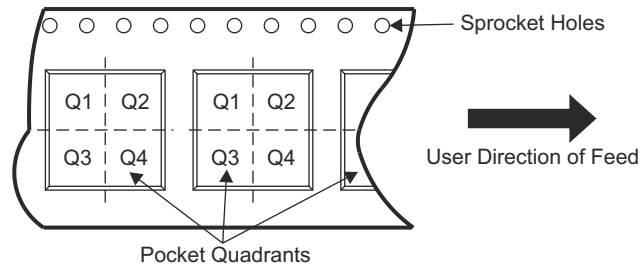
NOTES: (continued)

6. Laser cutting apertures with trapezoidal walls and rounded corners may offer better paste release. IPC-7525 may have alternate design recommendations.

### 13.1 Tape and Reel Information



#### QUADRANT ASSIGNMENTS FOR PIN 1 ORIENTATION IN TAPE



Device	Package Type	Package Drawing	Pins	SPQ	Reel Diameter (mm)	Reel Width W1 (mm)	A0 (mm)	B0 (mm)	K0 (mm)	P1 (mm)	W (mm)	Pin1 Quadrant
DRV8213DSGR	WSON	DSG	8	3000	180.0	8.4	2.3	2.3	1.15	4.0	8.0	Q2
DRV8213RTER	WQFN	RTE	16	3000	330.0	12.4	3.3	3.3	1.1	8.0	12.0	Q2

**TAPE AND REEL BOX DIMENSIONS**



Device	Package Type	Package Drawing	Pins	SPQ	Length (mm)	Width (mm)	Height (mm)
DRV8213DSGR	WSON	DSG	8	3000	2.0	2.0	0.8
DRV8213RTER	WQFN	RTE	16	3000	3.0	3.0	0.8



**PACKAGING INFORMATION**

Orderable Device	Status (1)	Package Type	Package Drawing	Pins	Package Qty	Eco Plan (2)	Lead finish/ Ball material (6)	MSL Peak Temp (3)	Op Temp (°C)	Device Marking (4/5)	Samples
DRV8213DSGR	ACTIVE	WSON	DSG	8	3000	RoHS & Green	NIPDAU	Level-1-260C-UNLIM	-40 to 125	8213	<a href="#">Samples</a>
DRV8213RTER	ACTIVE	WQFN	RTE	16	3000	RoHS & Green	NIPDAU	Level-1-260C-UNLIM	-40 to 125	8213	<a href="#">Samples</a>

(1) The marketing status values are defined as follows:

**ACTIVE:** Product device recommended for new designs.

**LIFEBUY:** TI has announced that the device will be discontinued, and a lifetime-buy period is in effect.

**NRND:** Not recommended for new designs. Device is in production to support existing customers, but TI does not recommend using this part in a new design.

**PREVIEW:** Device has been announced but is not in production. Samples may or may not be available.

**OBSOLETE:** TI has discontinued the production of the device.

(2) **RoHS:** TI defines "RoHS" to mean semiconductor products that are compliant with the current EU RoHS requirements for all 10 RoHS substances, including the requirement that RoHS substance do not exceed 0.1% by weight in homogeneous materials. Where designed to be soldered at high temperatures, "RoHS" products are suitable for use in specified lead-free processes. TI may reference these types of products as "Pb-Free".

**RoHS Exempt:** TI defines "RoHS Exempt" to mean products that contain lead but are compliant with EU RoHS pursuant to a specific EU RoHS exemption.

**Green:** TI defines "Green" to mean the content of Chlorine (Cl) and Bromine (Br) based flame retardants meet JS709B low halogen requirements of <=1000ppm threshold. Antimony trioxide based flame retardants must also meet the <=1000ppm threshold requirement.

(3) MSL, Peak Temp. - The Moisture Sensitivity Level rating according to the JEDEC industry standard classifications, and peak solder temperature.

(4) There may be additional marking, which relates to the logo, the lot trace code information, or the environmental category on the device.

(5) Multiple Device Markings will be inside parentheses. Only one Device Marking contained in parentheses and separated by a "~" will appear on a device. If a line is indented then it is a continuation of the previous line and the two combined represent the entire Device Marking for that device.

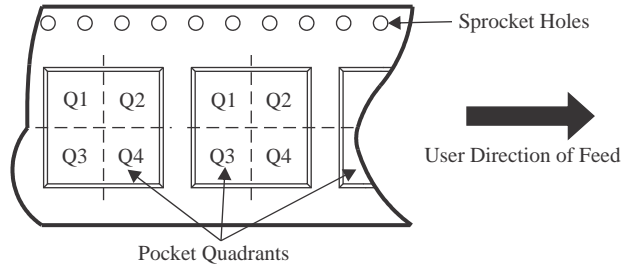
(6) Lead finish/Ball material - Orderable Devices may have multiple material finish options. Finish options are separated by a vertical ruled line. Lead finish/Ball material values may wrap to two lines if the finish value exceeds the maximum column width.

**Important Information and Disclaimer:**The information provided on this page represents TI's knowledge and belief as of the date that it is provided. TI bases its knowledge and belief on information provided by third parties, and makes no representation or warranty as to the accuracy of such information. Efforts are underway to better integrate information from third parties. TI has taken and continues to take reasonable steps to provide representative and accurate information but may not have conducted destructive testing or chemical analysis on incoming materials and chemicals. TI and TI suppliers consider certain information to be proprietary, and thus CAS numbers and other limited information may not be available for release.

In no event shall TI's liability arising out of such information exceed the total purchase price of the TI part(s) at issue in this document sold by TI to Customer on an annual basis.



**TAPE AND REEL INFORMATION**

**QUADRANT ASSIGNMENTS FOR PIN 1 ORIENTATION IN TAPE**


\*All dimensions are nominal

Device	Package Type	Package Drawing	Pins	SPQ	Reel Diameter (mm)	Reel Width W1 (mm)	A0 (mm)	B0 (mm)	K0 (mm)	P1 (mm)	W (mm)	Pin1 Quadrant
DRV8213DSGR	WSON	DSG	8	3000	180.0	8.4	2.3	2.3	1.15	4.0	8.0	Q2
DRV8213RTER	WQFN	RTE	16	3000	330.0	12.4	3.3	3.3	1.1	8.0	12.0	Q2

**TAPE AND REEL BOX DIMENSIONS**


\*All dimensions are nominal

Device	Package Type	Package Drawing	Pins	SPQ	Length (mm)	Width (mm)	Height (mm)
DRV8213DSGR	WSON	DSG	8	3000	210.0	185.0	35.0
DRV8213RTER	WQFN	RTE	16	3000	367.0	367.0	35.0

## GENERIC PACKAGE VIEW

**DSG 8**

**WSON - 0.8 mm max height**

2 x 2, 0.5 mm pitch

PLASTIC SMALL OUTLINE - NO LEAD

This image is a representation of the package family, actual package may vary.  
Refer to the product data sheet for package details.



4224783/A

# DSG0008A



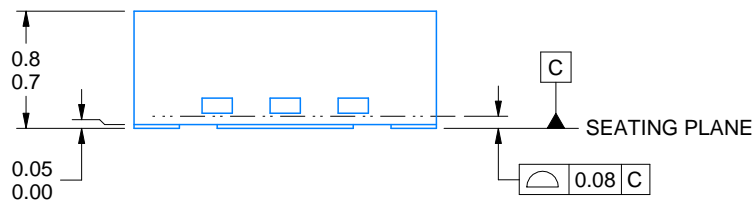
# PACKAGE OUTLINE

## WSON - 0.8 mm max height

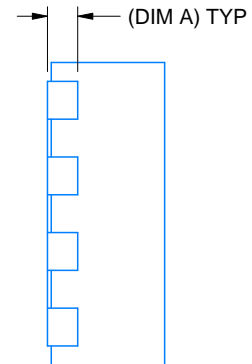
PLASTIC SMALL OUTLINE - NO LEAD



ALTERNATIVE TERMINAL SHAPE TYPICAL



SIDE WALL METAL THICKNESS DIM A	
OPTION 1	OPTION 2
0.1	0.2



4218900/E 08/2022

### NOTES:

1. All linear dimensions are in millimeters. Any dimensions in parenthesis are for reference only. Dimensioning and tolerancing per ASME Y14.5M.
2. This drawing is subject to change without notice.
3. The package thermal pad must be soldered to the printed circuit board for thermal and mechanical performance.

# EXAMPLE BOARD LAYOUT

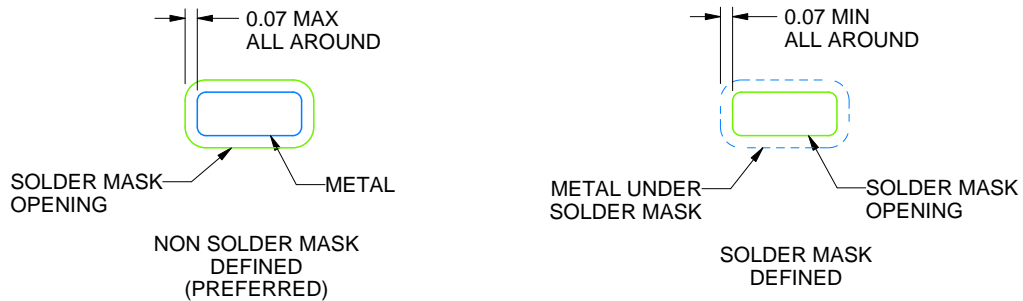
DSG0008A

WSON - 0.8 mm max height

PLASTIC SMALL OUTLINE - NO LEAD



LAND PATTERN EXAMPLE  
SCALE:20X



SOLDER MASK DETAILS

4218900/E 08/2022

NOTES: (continued)

4. This package is designed to be soldered to a thermal pad on the board. For more information, see Texas Instruments literature number SLUA271 ([www.ti.com/lit/slua271](http://www.ti.com/lit/slua271)).
5. Vias are optional depending on application, refer to device data sheet. If any vias are implemented, refer to their locations shown on this view. It is recommended that vias under paste be filled, plugged or tented.

# EXAMPLE STENCIL DESIGN

DSG0008A

WSON - 0.8 mm max height

PLASTIC SMALL OUTLINE - NO LEAD



SOLDER PASTE EXAMPLE  
BASED ON 0.125 mm THICK STENCIL

EXPOSED PAD 9:  
87% PRINTED SOLDER COVERAGE BY AREA UNDER PACKAGE  
SCALE:25X

4218900/E 08/2022

NOTES: (continued)

6. Laser cutting apertures with trapezoidal walls and rounded corners may offer better paste release. IPC-7525 may have alternate design recommendations.



## GENERIC PACKAGE VIEW

**RTE 16**

**WQFN - 0.8 mm max height**

3 x 3, 0.5 mm pitch

PLASTIC QUAD FLATPACK - NO LEAD

This image is a representation of the package family, actual package may vary.  
Refer to the product data sheet for package details.



4225944/A

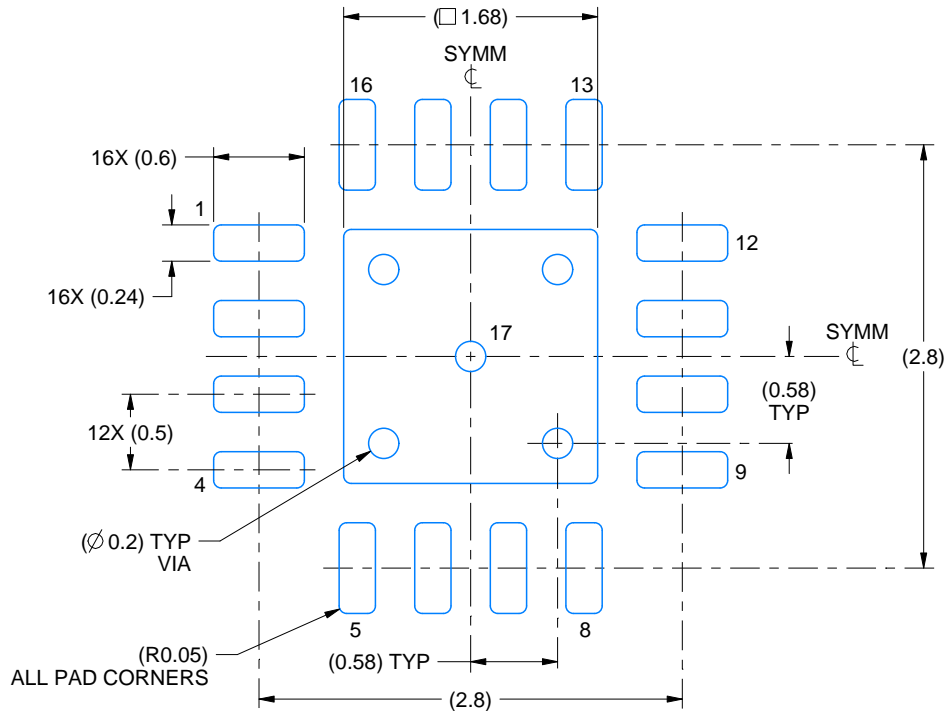


# EXAMPLE BOARD LAYOUT

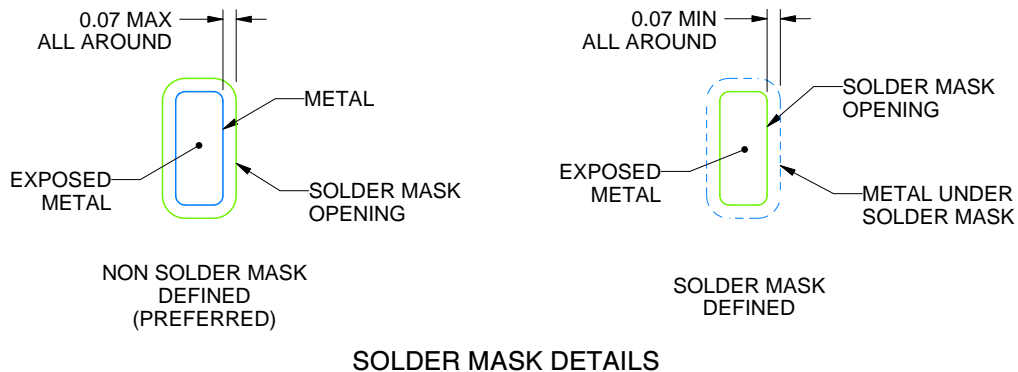
RTE0016C

WQFN - 0.8 mm max height

PLASTIC QUAD FLATPACK - NO LEAD



LAND PATTERN EXAMPLE  
EXPOSED METAL SHOWN  
SCALE:20X



SOLDER MASK DETAILS

4219117/B 04/2022

NOTES: (continued)

- This package is designed to be soldered to a thermal pad on the board. For more information, see Texas Instruments literature number SLUA271 ([www.ti.com/lit/slua271](http://www.ti.com/lit/slua271)).
- Vias are optional depending on application, refer to device data sheet. If any vias are implemented, refer to their locations shown on this view. It is recommended that vias under paste be filled, plugged or tented.

# EXAMPLE STENCIL DESIGN

RTE0016C

WQFN - 0.8 mm max height

PLASTIC QUAD FLATPACK - NO LEAD



**SOLDER PASTE EXAMPLE**  
BASED ON 0.125 mm THICK STENCIL

EXPOSED PAD 17:  
85% PRINTED SOLDER COVERAGE BY AREA UNDER PACKAGE  
SCALE:25X

4219117/B 04/2022

NOTES: (continued)

6. Laser cutting apertures with trapezoidal walls and rounded corners may offer better paste release. IPC-7525 may have alternate design recommendations.

## IMPORTANT NOTICE AND DISCLAIMER

TI PROVIDES TECHNICAL AND RELIABILITY DATA (INCLUDING DATA SHEETS), DESIGN RESOURCES (INCLUDING REFERENCE DESIGNS), APPLICATION OR OTHER DESIGN ADVICE, WEB TOOLS, SAFETY INFORMATION, AND OTHER RESOURCES "AS IS" AND WITH ALL FAULTS, AND DISCLAIMS ALL WARRANTIES, EXPRESS AND IMPLIED, INCLUDING WITHOUT LIMITATION ANY IMPLIED WARRANTIES OF MERCHANTABILITY, FITNESS FOR A PARTICULAR PURPOSE OR NON-INFRINGEMENT OF THIRD PARTY INTELLECTUAL PROPERTY RIGHTS.

These resources are intended for skilled developers designing with TI products. You are solely responsible for (1) selecting the appropriate TI products for your application, (2) designing, validating and testing your application, and (3) ensuring your application meets applicable standards, and any other safety, security, regulatory or other requirements.

These resources are subject to change without notice. TI grants you permission to use these resources only for development of an application that uses the TI products described in the resource. Other reproduction and display of these resources is prohibited. No license is granted to any other TI intellectual property right or to any third party intellectual property right. TI disclaims responsibility for, and you will fully indemnify TI and its representatives against, any claims, damages, costs, losses, and liabilities arising out of your use of these resources.

TI's products are provided subject to [TI's Terms of Sale](#) or other applicable terms available either on [ti.com](https://www.ti.com) or provided in conjunction with such TI products. TI's provision of these resources does not expand or otherwise alter TI's applicable warranties or warranty disclaimers for TI products.

TI objects to and rejects any additional or different terms you may have proposed.

Mailing Address: Texas Instruments, Post Office Box 655303, Dallas, Texas 75265  
Copyright © 2023, Texas Instruments Incorporated

## X-ON Electronics

Largest Supplier of Electrical and Electronic Components

*Click to view similar products for [Motor Drives](#) category:*

*Click to view products by [Texas Instruments](#) manufacturer:*

Other Similar products are found below :

[GMA02](#) [R7DBP02L](#) [1300920283](#) [GMA20](#) [R88ACRKN020CRE](#) [R88DUA03LAAC100V30W](#) [R88DUP03LAAC100V30W](#)  
[MFECA0050EAM](#) [MFECA0030EAM](#) [1300920078](#) [R88D-GT04H](#) [R88D-KT01H](#) [R7D-BP01H](#) [STAC6-QE](#) [R88ACR1A005CF](#)  
[R88D1SN04HECT](#) [R88D1SN08HECT](#) [R88ACR1A003CFRA](#) [K6CMISZBI52](#) [3G3MX2-AB002-E](#) [KLC35BE](#) [R88A-CA1A010B](#) [ST10-IP-](#)  
[EE](#) [ST10-Q-RN](#) [103H7121-0410P](#) [103H7123-0440P](#) [103H7126-0740P](#) [103H7126-5740P](#) [103H7823-5740P](#) [SMCV6150](#) [U-](#)  
[PKZ0\(480V60HZ\)](#) [ODE-3-120070-1F1A-01](#) [ODE-3-240041-3F4B](#) [ODE-3-120070-1F1B-01](#) [132B0107](#) [68581737](#) [3AUA0000072069](#)  
[3AUA0000089109](#) [ODE-3-220105-1F4B](#) [1SFA897103R7000](#) [1SFA897102R7000](#) [3AUA0000058190](#) [68581974](#) [68581796](#) [MCD 201-007-](#)  
[T4-CV1](#) [3AUA0000039627](#) [3AXD50000031889](#) [ATS22D17Q](#) [3AXD50000716630](#) [3AUA0000058169](#)