

## 具有开漏比较器和基准的 INA20x 高侧测量电流分流监控器

### 1 特性

- 完整电流感测解决方案
- 三种增益可供选择：
  - INA200 = 20V/V
  - INA201 = 50V/V
  - INA202 = 100V/V
- 0.6V 内部电压基准
- 内部漏极开路比较器
- 比较器锁存功能
- 共模范围：-16V 至 80V
- 高精度：整个温度范围内的最大误差为 3.5%
- 带宽：500kHz (INA200)
- 静态电流：1800 $\mu$ A (最大值)
- 封装：SOIC-8、VSSOP-8

### 2 应用

- 笔记本电脑
- 手机
- 电信设备
- 汽车
- 电源管理
- 电池充电器
- 焊接设备

### 3 说明

INA200、INA201 和 INA202 器件是具有电压输出和集成比较器的高侧电流分流监控器。INA20x 器件能够在 -16V 至 +80V 范围内的共模电压下感测分流器两端的压降。INA20x 系列器件可提供三种输出电压级别，即 20V/V、50V/V 和 100V/V，带宽高达 500kHz。

INA200、INA201 和 INA202 器件整合了一个开漏比较器以及提供 0.6V 阈值的内部基准。外部分压器可设定电流跳变点。比较器具有锁存功能，可通过将 **RESET** 引脚接地（或悬空）进入透明状态。

INA200、INA201 和 INA202 器件由单个 2.7V 至 18V 电源供电，消耗的最大电源电流为 1800 $\mu$ A。封装选项包括极小型 VSSOP-8 和

SOIC-8。所有版本的额定扩展工作温度范围均为 -40°C 至 +125°C。

#### 器件信息(1)

器件型号	封装	封装尺寸 (标称值)
INA200	SOIC (8)	4.90mm x 3.91mm
INA201	VSSOP (8)	3.00mm x 3.00mm
INA202		

(1) 如需了解所有可用封装，请参阅数据表末尾的可订购产品附录。

简化电路原理图

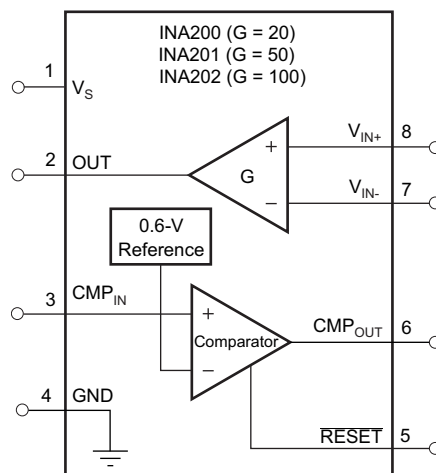

Copyright © 2017, Texas Instruments Incorporated



## 目录

<p><b>1 特性</b> ..... 1</p> <p><b>2 应用</b> ..... 1</p> <p><b>3 说明</b> ..... 1</p> <p><b>4 修订历史记录</b> ..... 2</p> <p><b>5 Pin Configuration and Functions</b> ..... 3</p> <p><b>6 Specifications</b> ..... 4</p> <p>    6.1 Absolute Maximum Ratings ..... 4</p> <p>    6.2 ESD Ratings ..... 4</p> <p>    6.3 Recommended Operating Conditions ..... 4</p> <p>    6.4 Thermal Information ..... 4</p> <p>    6.5 Electrical Characteristics: Current-Shunt Monitor ..... 5</p> <p>    6.6 Electrical Characteristics: Comparator ..... 7</p> <p>    6.7 Electrical Characteristics: General ..... 7</p> <p>    6.8 Typical Characteristics ..... 9</p> <p><b>7 Detailed Description</b> ..... 13</p> <p>    7.1 Overview ..... 13</p> <p>    7.2 Functional Block Diagram ..... 13</p>	<p>    7.3 Feature Description ..... 13</p> <p>    7.4 Device Functional Modes ..... 19</p> <p><b>8 Application and Implementation</b> ..... 22</p> <p>    8.1 Application Information ..... 22</p> <p>    8.2 Typical Application ..... 22</p> <p><b>9 Power Supply Recommendations</b> ..... 23</p> <p>    9.1 Output vs Supply Ramp Considerations ..... 23</p> <p><b>10 Layout</b> ..... 25</p> <p>    10.1 Layout Guidelines ..... 25</p> <p>    10.2 Layout Example ..... 25</p> <p><b>11 器件和文档支持</b> ..... 26</p> <p>    11.1 相关链接 ..... 26</p> <p>    11.2 社区资源 ..... 26</p> <p>    11.3 商标 ..... 26</p> <p>    11.4 静电放电警告 ..... 26</p> <p>    11.5 Glossary ..... 26</p> <p><b>12 机械、封装和可订购信息</b> ..... 26</p>
---------------------------------------------------------------------------------------------------------------------------------------------------------------------------------------------------------------------------------------------------------------------------------------------------------------------------------------------------------------------------------------------------------------------------------------------------------------------------------------------------------------------------------------------------------------------------------------------------------------------------------------------------------------------------------------------------------------------------------------------------------------------------------------	--------------------------------------------------------------------------------------------------------------------------------------------------------------------------------------------------------------------------------------------------------------------------------------------------------------------------------------------------------------------------------------------------------------------------------------------------------------------------------------------------------------------------------------------------------------------------------------------------------------------------------------------------------------------------------------------------------------------------

## 4 修订历史记录

注：之前版本的页码可能与当前版本有所不同。

Changes from Revision D (October 2015) to Revision E	Page
• Reformatted <i>Thermal Information</i> table note ..... 4	4
• Corrected typo in <i>Voltage Output</i> section in <i>Electrical Characteristics</i> table ..... 6	6
• 已添加 text to <i>Comparator</i> subsection in <i>Feature Description</i> section ..... 14	14
• 已添加 图 31 to <i>Feature Description</i> section ..... 18	18
• 已添加 <i>Output vs Supply Ramp Considerations</i> subsection in <i>Feature Description</i> section ..... 23	23
• 已添加 图 36, 图 37, and 图 38 ..... 23	23

Changes from Revision C (October 2010) to Revision D	Page
• Added <i>ESD Ratings</i> table, <i>Thermal Information</i> table, <i>Feature Description</i> section, <i>Device Functional Modes</i> , <i>Application and Implementation</i> section, <i>Power Supply Recommendations</i> section, <i>Layout</i> section, <i>Device and Documentation Support</i> section, and <i>Mechanical, Packaging, and Orderable Information</i> section ..... 4	4

Changes from Revision B (October, 2007) to Revision C	Page
• 修改了首页上的原理图 ..... 1	1
• 已更改 数据表标题 ..... 1	1
• 根据最新标准更新了文档格式 ..... 1	1

## 5 Pin Configuration and Functions

**DGK and D Packages  
8-Pin VSSOP and SOIC  
Top View**

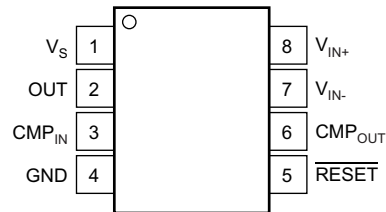

**Pin Functions**

PIN		I/O	DESCRIPTION
NAME	NO.		
CMP <sub>IN</sub>	3	Analog input	Comparator input
CMP <sub>OUT</sub>	6	Analog output	Comparator output
GND	4	Analog	Ground
OUT	2	Analog output	Output voltage
$\overline{\text{RESET}}$	5	Analog input	Comparator reset pin, active low
V <sub>IN-</sub>	7	Analog input	Connect to shunt low side
V <sub>IN+</sub>	8	Analog input	Connect to shunt high side
V <sub>S</sub>	1	Analog	Power supply

## 6 Specifications

### 6.1 Absolute Maximum Ratings

over operating free-air temperature range (unless otherwise noted)<sup>(1)</sup>

		MIN	MAX	UNIT
Supply voltage, $V_s$		2.7	18	V
Current-shunt monitor analog inputs, $V_{IN+}$ , $V_{IN-}$	Differential ( $V_{IN+}$ ) – ( $V_{IN-}$ )	–18	18	V
	Common-mode <sup>(2)</sup>	–16	80	V
Comparator analog input and reset pins <sup>(2)</sup>		GND – 0.3	( $V_s$ ) + 0.3	V
Analog output, OUT <sup>(2)</sup>		GND – 0.3	( $V_s$ ) + 0.3	V
Comparator output, OUT <sup>(2)</sup>		GND – 0.3	18	V
Input current into any pin <sup>(2)</sup>			5	mA
Operating temperature		–55	150	°C
Junction temperature		–65	150	°C
Storage temperature, $T_{stg}$		–65	150	°C

- (1) Stresses beyond those listed under *Absolute Maximum Ratings* may cause permanent damage to the device. These are stress ratings only, which do not imply functional operation of the device at these or any other conditions beyond those indicated under *Recommended Operating Conditions*. Exposure to absolute-maximum-rated conditions for extended periods may affect device reliability.
- (2) This voltage may exceed the ratings shown if the current at that pin is limited to 5 mA.

### 6.2 ESD Ratings

		VALUE	UNIT
$V_{(ESD)}$ Electrostatic discharge	Human body model (HBM), per ANSI/ESDA/JEDEC JS-001, all pins <sup>(1)</sup>	±4000	V
	Charged device model (CDM), per JEDEC specification JESD22-C101, all pins <sup>(2)</sup>	±1000	

- (1) JEDEC document JEP155 states that 500-V HBM allows safe manufacturing with a standard ESD control process.

- (2) JEDEC document JEP157 states that 250-V CDM allows safe manufacturing with a standard ESD control process.

### 6.3 Recommended Operating Conditions

over operating free-air temperature range (unless otherwise noted)

		MIN	NOM	MAX	UNIT
$V_{CM}$	Common-mode input voltage	–16	12	80	V
$V_s$	Operating supply voltage	2.7	12	18	V
$T_A$	Operating free-air temperature	–40	25	125	°C

### 6.4 Thermal Information

THERMAL METRIC <sup>(1)</sup>	INA20x		UNIT	
	D (SOIC)	DGK (SOIC)		
	8 PINS	8 PINS		
$R_{\theta JA}$	Junction-to-ambient thermal resistance	110.5	162.2	°C/W
$R_{\theta JC(top)}$	Junction-to-case (top) thermal resistance	50.4	37.7	°C/W
$R_{\theta JB}$	Junction-to-board thermal resistance	52.7	82.9	°C/W
$\Psi_{JT}$	Junction-to-top characterization parameter	7.8	1.3	°C/W
$\Psi_{JB}$	Junction-to-board characterization parameter	51.9	81.4	°C/W

- (1) For more information about traditional and new thermal metrics, see the [Semiconductor and IC Package Thermal Metrics](#) application report.

## 6.5 Electrical Characteristics: Current-Shunt Monitor

at  $T_A = 25^\circ\text{C}$ ,  $V_S = 12\text{ V}$ ,  $V_{\text{CM}} = 12\text{ V}$ ,  $V_{\text{SENSE}} = 100\text{ mV}$ ,  $R_L = 10\text{ k}\Omega$  to GND,  $R_{\text{PULL-UP}} = 5.1\text{ k}\Omega$  connected from  $\text{CMP}_{\text{OUT}}$  to  $V_S$ , and  $\text{CMP}_{\text{IN}} = \text{GND}$ , (unless otherwise noted)

PARAMETER		TEST CONDITIONS	MIN	TYP	MAX	UNIT
<b>INPUT</b>						
$V_{\text{SENSE}}$	Full-scale sense input voltage	$V_{\text{SENSE}} = V_{\text{IN+}} - V_{\text{IN-}}$		0.15	$(V_S - 0.25) / \text{Gain}$	V
$V_{\text{CM}}$	Common-mode input range	$T_A = -40^\circ\text{C}$ to $125^\circ\text{C}$	-16		80	V
CMR	Common-mode rejection	$V_{\text{IN+}} = -16\text{ V}$ to $80\text{ V}$	80	100		dB
		$V_{\text{IN+}} = 12\text{ V}$ to $80\text{ V}$ , $T_A = -40^\circ\text{C}$ to $125^\circ\text{C}$	100	123		dB
$V_{\text{OS}}$	Offset voltage, RTI <sup>(1)</sup>	$T_A = 25^\circ\text{C}$		$\pm 0.5$	$\pm 2.5$	mV
		$T_A = 25^\circ\text{C}$ to $125^\circ\text{C}$			$\pm 3$	mV
		$T_A = -40^\circ\text{C}$ to $25^\circ\text{C}$			$\pm 3.5$	mV
$dV_{\text{OS}}/dT$	Offset voltage, RTI, vs temperature	$T_{\text{MIN}}$ to $T_{\text{MAX}}$ , $T_A = -40^\circ\text{C}$ to $125^\circ\text{C}$		5		$\mu\text{V}/^\circ\text{C}$
PSR	Offset voltage, RTI, vs power supply	$V_{\text{OUT}} = 2\text{ V}$ , $V_{\text{IN+}} = 18\text{ V}$ , $2.7\text{ V}$ , $T_A = -40^\circ\text{C}$ to $125^\circ\text{C}$		2.5	100	$\mu\text{V}/\text{V}$
$I_B$	Input bias current, $V_{\text{IN-}}$ pin	$T_A = -40^\circ\text{C}$ to $125^\circ\text{C}$		$\pm 9$	$\pm 16$	$\mu\text{A}$

(1) Offset is extrapolated from measurements of the output at 20-mV and 100-mV  $V_{\text{SENSE}}$ .

**Electrical Characteristics: Current-Shunt Monitor (continued)**

at  $T_A = 25^\circ\text{C}$ ,  $V_S = 12\text{ V}$ ,  $V_{CM} = 12\text{ V}$ ,  $V_{SENSE} = 100\text{ mV}$ ,  $R_L = 10\text{ k}\Omega$  to GND,  $R_{PULL-UP} = 5.1\text{ k}\Omega$  connected from  $CMP_{OUT}$  to  $V_S$ , and  $CMP_{IN} = \text{GND}$ , (unless otherwise noted)

PARAMETER		TEST CONDITIONS	MIN	TYP	MAX	UNIT
<b>OUTPUT (<math>V_{SENSE} \geq 20\text{ mV}</math>)</b>						
G	Gain	INA200		20		V/V
		INA201		50		V/V
		INA202		100		V/V
	Gain error	$V_{SENSE} = 20\text{ mV to }100\text{ mV}$		$\pm 0.2\%$	$\pm 1\%$	
		$V_{SENSE} = 20\text{ mV to }100\text{ mV}$ , $T_A = -40^\circ\text{C to }125^\circ\text{C}$				$\pm 2\%$
	Total output error <sup>(2)</sup>	$V_{SENSE} = 120\text{ mV}$ , $V_S = 16\text{ V}$		$\pm 0.75\%$	$\pm 2.2\%$	
		$V_{SENSE} = 120\text{ mV}$ , $V_S = 16\text{ V}$ , $T_A = -40^\circ\text{C to }125^\circ\text{C}$				$\pm 3.5\%$
	Nonlinearity error <sup>(3)</sup>	$V_{SENSE} = 20\text{ mV to }100\text{ mV}$		$\pm 0.002\%$		
$R_O$	Output impedance			1.5		$\Omega$
	Maximum capacitive load	No sustained oscillation		10		nF
<b>OUTPUT (<math>V_{SENSE} &lt; 20\text{ mV}</math>)<sup>(4)</sup></b>						
Output	INA200, INA201, INA202	$-16\text{ V} \leq V_{CM} < 0\text{ V}$		300		mV
	INA200	$0\text{ V} \leq V_{CM} \leq V_S$ , $V_S = 5\text{ V}$			0.4	V
	INA201	$0\text{ V} \leq V_{CM} \leq V_S$ , $V_S = 5\text{ V}$			1	V
	INA202	$0\text{ V} \leq V_{CM} \leq V_S$ , $V_S = 5\text{ V}$			2	V
	INA200, INA201, INA202	$V_S < V_{CM} \leq 80\text{ V}$		300		mV
<b>VOLTAGE OUTPUT<sup>(5)</sup></b>						
	Output swing to the positive rail	$V_{IN-} = 11\text{ V}$ , $V_{IN+} = 12\text{ V}$ , $T_A = -40^\circ\text{C to }125^\circ\text{C}$		$(V_S) - 0.15$	$(V_S) - 0.25$	V
	Output swing to GND <sup>(6)</sup>	$V_{IN-} = 0\text{ V}$ , $V_{IN+} = -0.5\text{ V}$ , $T_A = -40^\circ\text{C to }125^\circ\text{C}$		$(\text{GND}) + 0.004$	$(\text{GND}) + 0.05$	V
<b>FREQUENCY RESPONSE</b>						
BW	Bandwidth	INA200	$C_{LOAD} = 5\text{ pF}$	500		kHz
		INA201	$C_{LOAD} = 5\text{ pF}$	300		kHz
		INA202	$C_{LOAD} = 5\text{ pF}$	200		kHz
	Phase margin	$C_{LOAD} < 10\text{ nF}$		40		$^\circ\text{C}$
SR	Slew rate			1		V/ $\mu\text{s}$
	Settling time (1%)	$V_{SENSE} = 10\text{ mV}_{PP}$ to $100\text{ mV}_{PP}$ , $C_{LOAD} = 5\text{ pF}$		2		$\mu\text{s}$
<b>NOISE, RTI</b>						
	Voltage noise density			40		nV/ $\sqrt{\text{Hz}}$

(2) Total output error includes effects of gain error and  $V_{OS}$ .

(3) Linearity is best fit to a straight line.

(4) For details on this region of operation, see [Accuracy Variations](#) section in [Device Functional Modes](#).

(5) See [Figure 8](#).

(6) Specified by design.

## 6.6 Electrical Characteristics: Comparator

at  $T_A = 25^\circ\text{C}$ ,  $V_S = 12\text{ V}$ ,  $V_{CM} = 12\text{ V}$ ,  $V_{SENSE} = 100\text{ mV}$ ,  $R_L = 10\text{ k}\Omega$  to GND, and  $R_{PULL-UP} = 5.1\text{ k}\Omega$  connected from  $CMP_{OUT}$  to  $V_S$ , (unless otherwise noted)

PARAMETER	TEST CONDITIONS	MIN	TYP	MAX	UNIT
<b>OFFSET VOLTAGE</b>					
Threshold	$T_A = 25^\circ\text{C}$	590	608	620	mV
	$T_A = -40^\circ\text{C}$ to $125^\circ\text{C}$	586		625	mV
Hysteresis <sup>(1)</sup>	$T_A = -40^\circ\text{C}$ to $85^\circ\text{C}$		-8		mV
<b>INPUT BIAS CURRENT<sup>(2)</sup></b>					
Input bias current, $CMP_{in}$ PIN			0.005	10	nA
Input bias current, $CMP_{in}$ PIN, vs temperature	$T_A = -40^\circ\text{C}$ to $125^\circ\text{C}$			15	nA
<b>INPUT VOLTAGE RANGE</b>					
Input voltage range, $CMP_{in}$ PIN		0 V to $V_S - 1.5\text{ V}$			V
<b>OUTPUT (OPEN-DRAIN)</b>					
Large-signal differential voltage gain	$CMP\ V_{OUT} 1\text{ V}$ to $4\text{ V}$ , $R_L \geq 15\text{ k}\Omega$ connected to $5\text{ V}$		200		V/mV
$I_{LKG}$ High-level leakage current <sup>(3)(4)</sup>	$V_{ID} = 0.4\text{ V}$ , $V_{OH} = V_S$		0.0001	1	$\mu\text{A}$
$V_{OL}$ Low-level output voltage <sup>(3)</sup>	$V_{ID} = -0.6\text{ V}$ , $I_{OL} = 2.35\text{ mA}$		220	300	mV
<b>RESPONSE TIME</b>					
Response time <sup>(5)</sup>	$R_L$ to $5\text{ V}$ , $C_L = 15\text{ pF}$ , 100-mV Input Step with 5-mV overdrive		1.3		$\mu\text{s}$
<b>RESET</b>					
RESET threshold <sup>(6)</sup>			1.1		V
Logic input impedance			2		$\text{M}\Omega$
Minimum RESET pulse width			1.5		$\mu\text{s}$
RESET propagation delay			3		$\mu\text{s}$

- (1) Hysteresis refers to the threshold (the threshold specification applies to a rising edge of a noninverting input) of a falling edge on the noninverting input of the comparator; refer to [Fig. 1](#).
- (2) Specified by design.
- (3)  $V_{ID}$  refers to the differential voltage at the comparator inputs.
- (4) Open-drain output can be pulled to the range of 2.7 to 18 V, regardless of  $V_S$ .
- (5) The comparator response time specified is the interval between the input step function and the instant when the output crosses 1.4 V.
- (6) The RESET input has an internal 2 M $\Omega$  (typical) pull-down. Leaving RESET open results in a LOW state, with transparent comparator operation.

## 6.7 Electrical Characteristics: General

at  $T_A = 25^\circ\text{C}$ ,  $V_S = 12\text{ V}$ ,  $V_{CM} = 12\text{ V}$ ,  $V_{SENSE} = 100\text{ mV}$ ,  $R_L = 10\text{ k}\Omega$  to GND,  $R_{PULL-UP} = 5.1\text{ k}\Omega$  connected from  $CMP_{OUT}$  to  $V_S$ , and  $CMP_{IN} = 1\text{ V}$ , unless otherwise noted.

PARAMETER	TEST CONDITIONS	MIN	TYP	MAX	UNIT
<b>POWER SUPPLY</b>					
$V_S$ Operating power supply	$T_A = -40^\circ\text{C}$ to $125^\circ\text{C}$	2.7		18	V
$I_Q$ Quiescent current	$V_{OUT} = 2\text{ V}$		1350	1800	$\mu\text{A}$
	$V_{SENSE} = 0\text{ mV}$ , $T_A = -40^\circ\text{C}$ to $125^\circ\text{C}$			1850	$\mu\text{A}$
Comparator power-on reset threshold <sup>(1)</sup>			1.5		V
<b>TEMPERATURE</b>					
Specified temperature		-40		125	$^\circ\text{C}$
Operating temperature		-55		150	$^\circ\text{C}$
Storage temperature		-65		150	$^\circ\text{C}$
$\theta_{JA}$ Thermal resistance	VSSOP-8 Surface-Mount		200		$^\circ\text{C}/\text{W}$
	SOIC-8		150		$^\circ\text{C}/\text{W}$

- (1) The INA200, INA201, and INA202 are designed to power-up with the comparator in a defined reset state as long as RESET is open or grounded. The comparator is in reset as long as the power supply is below the voltage shown here. The comparator assumes a state based on the comparator input above this supply voltage. If RESET is high at power-up, the comparator output comes up high and requires a reset to assume a low state, if appropriate.

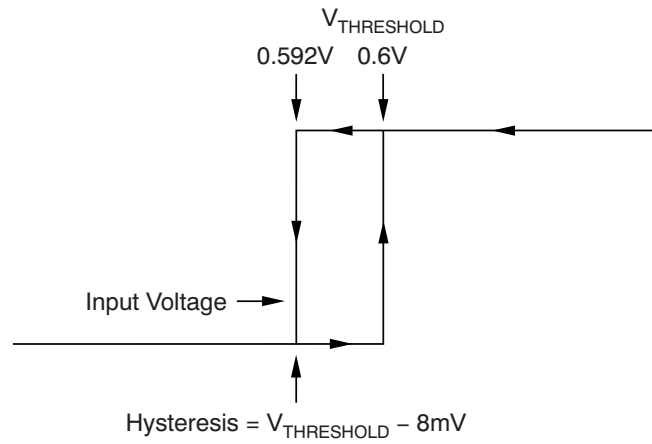

**图 1. Typical Comparator Hysteresis**



### 6.8 Typical Characteristics

at  $T_A = 25^\circ\text{C}$ ,  $V_S = 12\text{ V}$ ,  $V_{IN+} = 12\text{ V}$ , and  $V_{SENSE} = 100\text{ mV}$ , (unless otherwise noted)



图 2. Gain vs Frequency



图 3. Gain vs Frequency

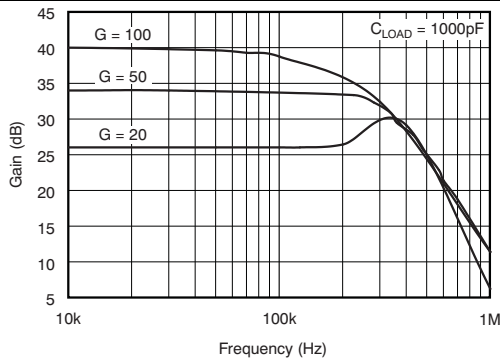

图 4. Gain Plot

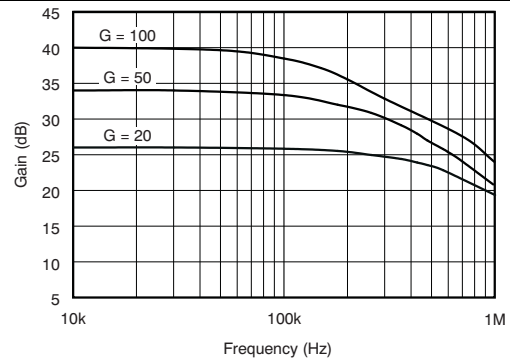

图 5. Common-Mode and Power-Supply Rejection vs Frequency

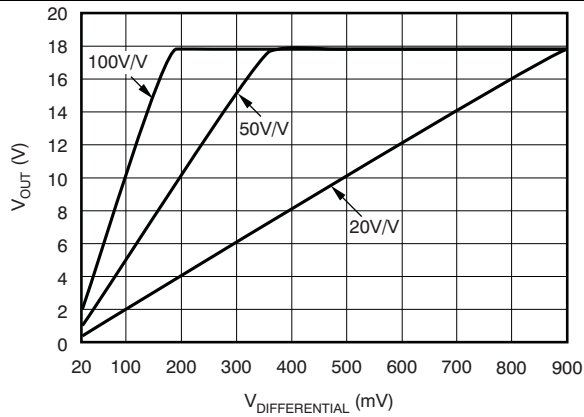

图 6. Output Error vs  $V_{SENSE}$

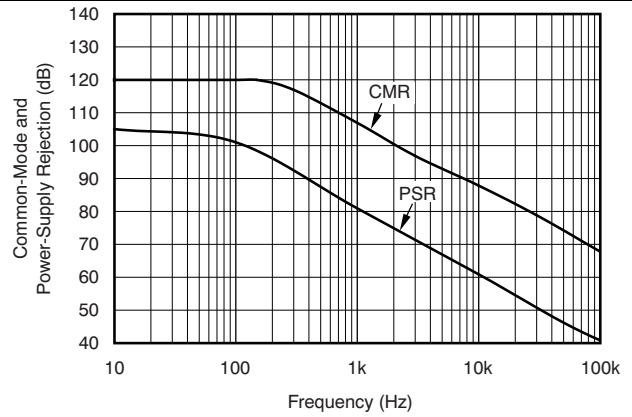

图 7. Output Error vs Common-Mode Voltage

Typical Characteristics (接下页)

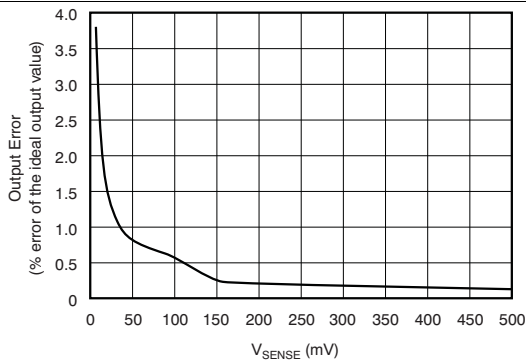
at  $T_A = 25^\circ\text{C}$ ,  $V_S = 12\text{ V}$ ,  $V_{IN+} = 12\text{ V}$ , and  $V_{SENSE} = 100\text{ mV}$ , (unless otherwise noted)

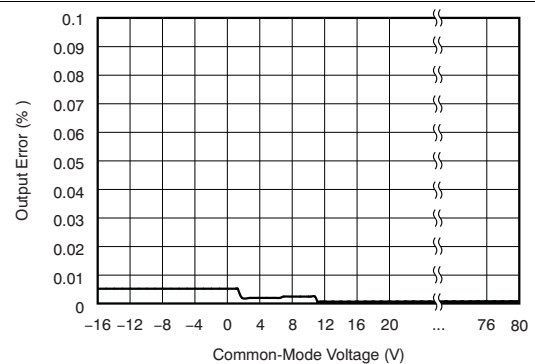

图 8. Positive Output Voltage Swing vs Output Current



图 9. Quiescent Current vs Output Voltage

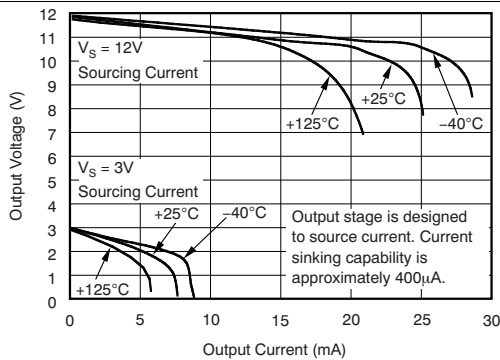

图 10. Quiescent Current vs Common-Mode Voltage

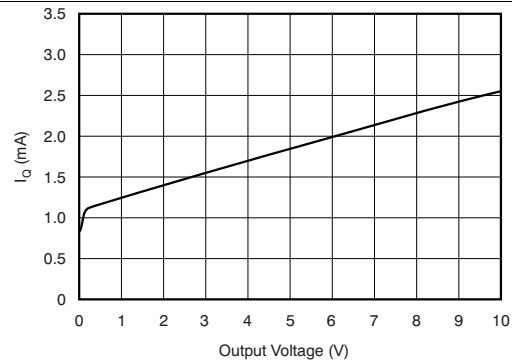

图 11. Output Short-Circuit Current vs Supply Voltage

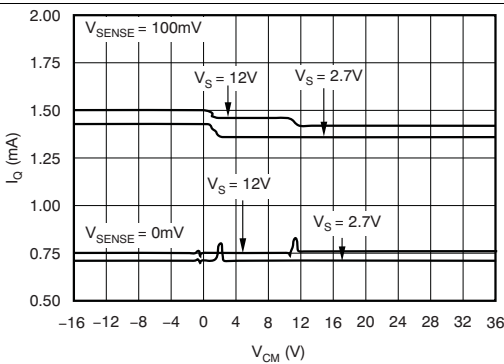

图 12. Step Response

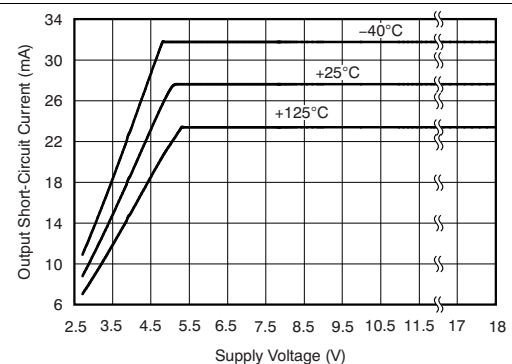

图 13. Step Response

Typical Characteristics (接下页)

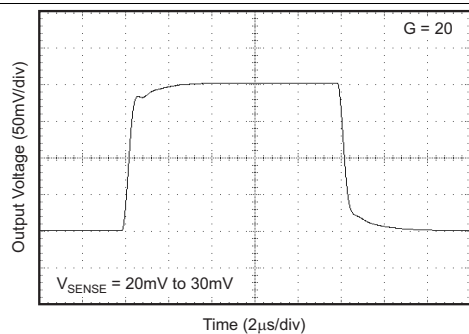
at  $T_A = 25^\circ\text{C}$ ,  $V_S = 12\text{ V}$ ,  $V_{IN+} = 12\text{ V}$ , and  $V_{SENSE} = 100\text{ mV}$ , (unless otherwise noted)

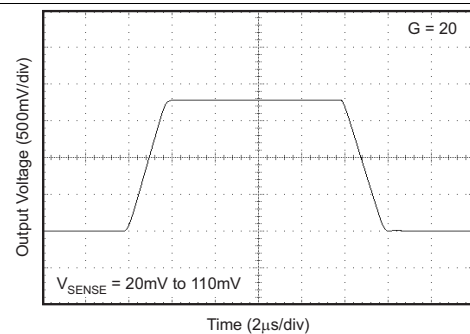

图 14. Step Response



图 15. Step Response

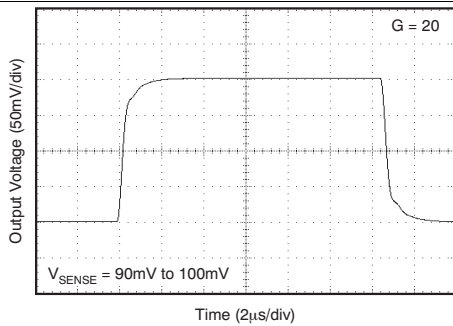

图 16. Step Response

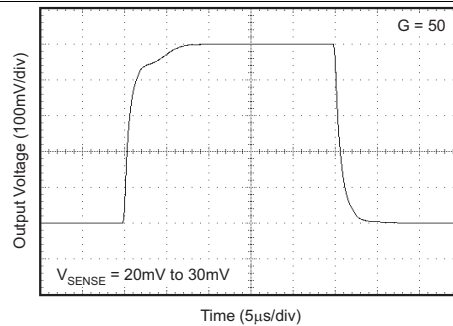

图 17. Step Response

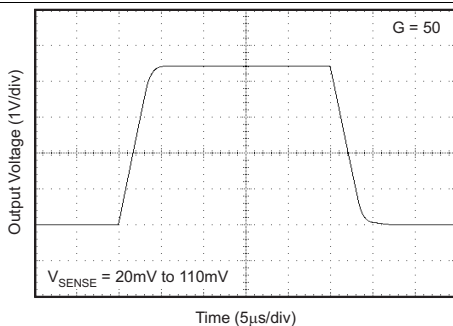

图 18. Step Response

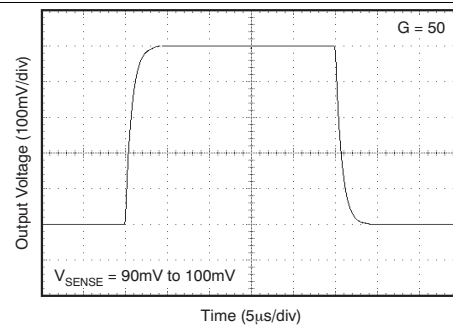

图 19. Comparator  $V_{OL}$  vs  $I_{SINK}$

Typical Characteristics (接下页)

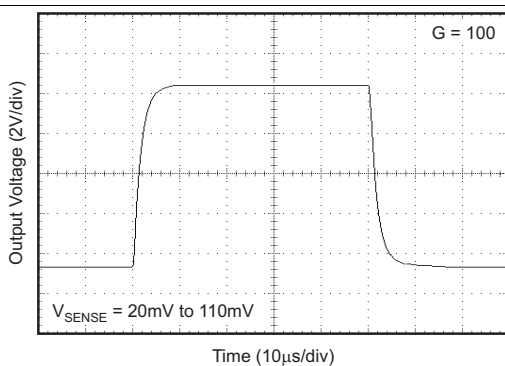
at  $T_A = 25^\circ\text{C}$ ,  $V_S = 12\text{ V}$ ,  $V_{IN+} = 12\text{ V}$ , and  $V_{SENSE} = 100\text{ mV}$ , (unless otherwise noted)

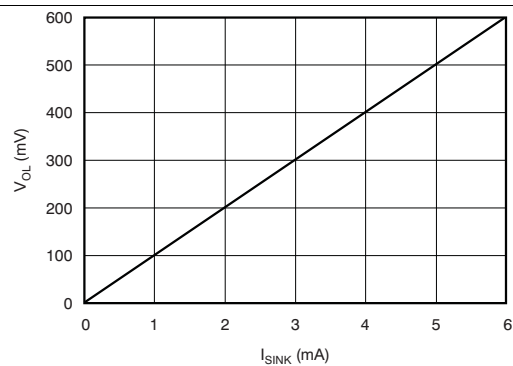

图 20. Comparator Trip Point vs Supply Voltage



图 21. Comparator Trip Point vs Temperature

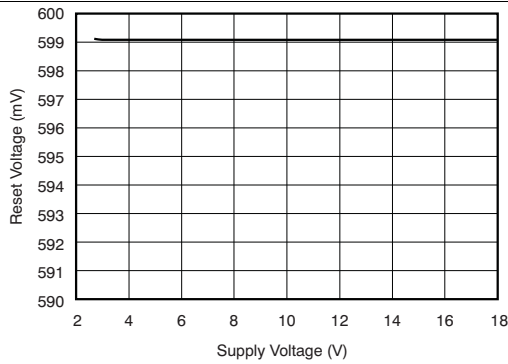

图 22. Comparator Propagation Delay vs Overdrive Voltage

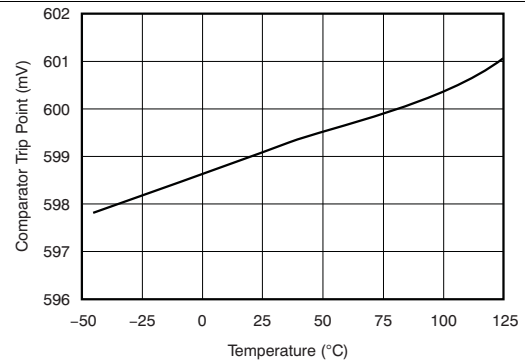

图 23. Comparator Reset Voltage vs Supply Voltage



图 24. Comparator Propagation Delay vs Temperature

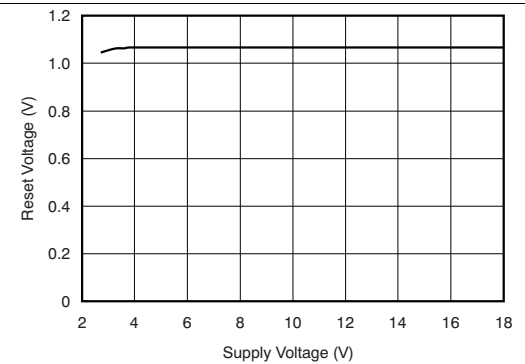

图 25. Comparator Propagation Delay

## 7 Detailed Description

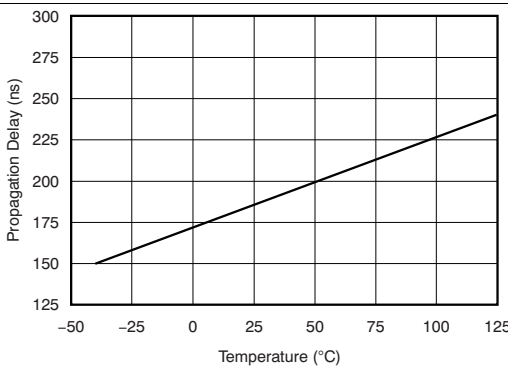
### 7.1 Overview

The INA200, INA201, and INA202 devices are high-side current-shunt monitors with voltage output. The INA20x devices can sense drops across shunts at common-mode voltages from  $-16\text{ V}$  to  $80\text{ V}$ . The INA200–INA202 devices are available with three output voltage scales:  $20\text{ V/V}$ ,  $50\text{ V/V}$ , and  $100\text{ V/V}$ , with up to  $500\text{-kHz}$  bandwidth. The INA200, INA201, and INA202 devices incorporate an open-drain comparator and internal reference providing a  $0.6\text{-V}$  threshold. External dividers set the current trip point. The comparator includes a latching capability, that can be made transparent by grounding (or leaving open) the RESET pin. The INA200, INA201, and INA202 devices operate from a single  $2.7$  to  $18\text{-V}$  supply, drawing a maximum of  $1800\text{ }\mu\text{A}$  of supply current. Package options include the very small MSOP-8 and the SO-8. All versions are specified over the extended operating temperature range of  $-40^{\circ}\text{C}$  to  $+125^{\circ}\text{C}$ .

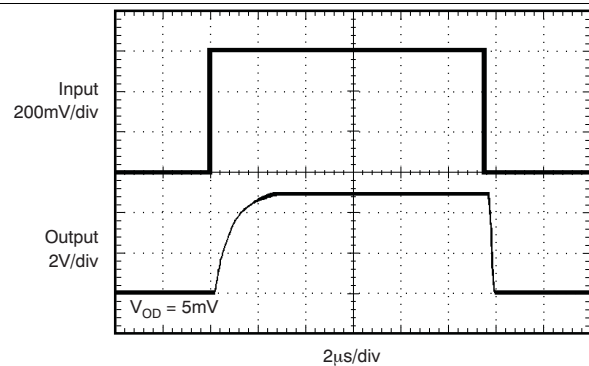
### 7.2 Functional Block Diagram

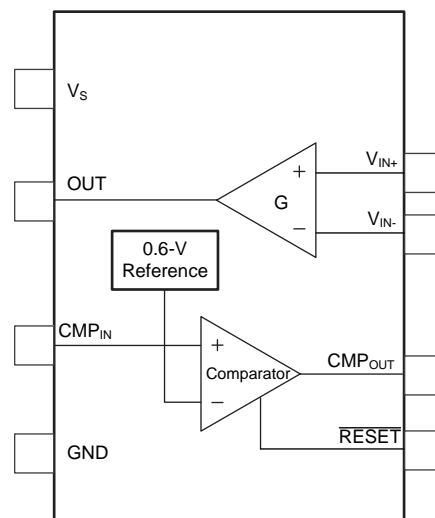

### 7.3 Feature Description

#### 7.3.1 Basic Connections

 26 shows the basic connections of the INA20x devices. The input pins ( $V_{IN+}$  and  $V_{IN-}$ ) must be connected as closely as possible with Kelvin connections to the shunt resistor to minimize any resistance in series with the shunt resistance.

Power-supply bypass capacitors are required for stability. Applications with noisy or high-impedance power supplies may require additional decoupling capacitors to reject power-supply noise. Connect bypass capacitors close to the device pins.

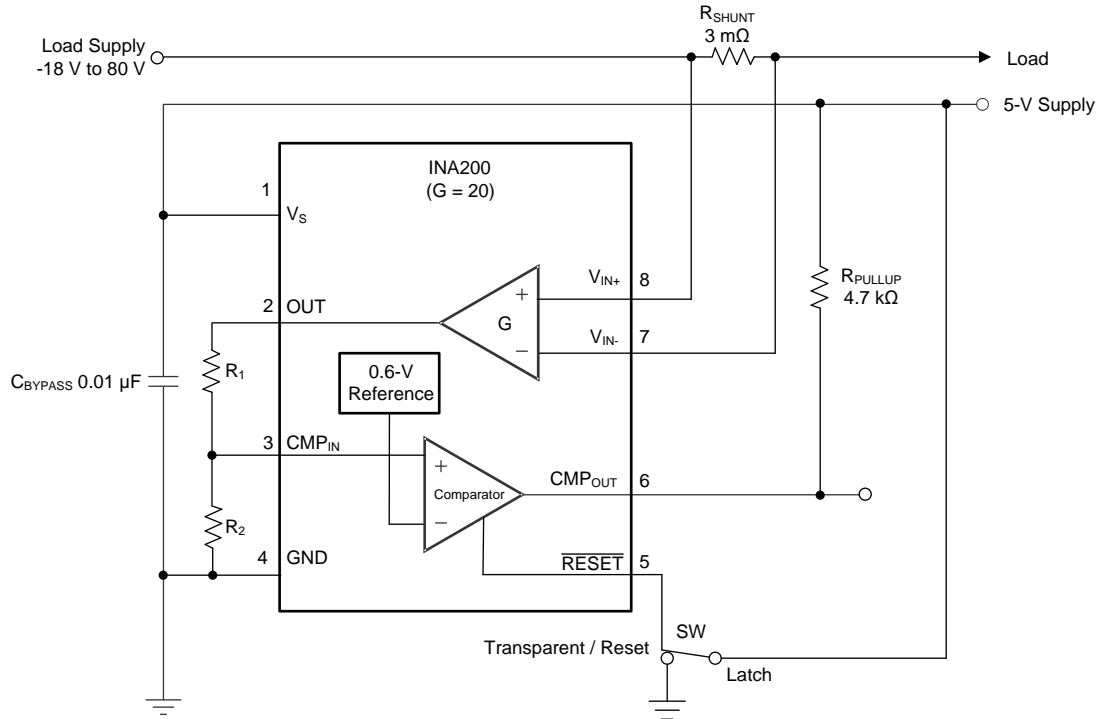

Copyright © 2017, Texas Instruments Incorporated

**图 26. INA200 Basic Connections**

### 7.3.2 Selecting $R_S$

The selected value for the shunt resistor,  $R_S$ , depends on the application and is a compromise between small-signal accuracy and maximum permissible voltage loss in the measurement line. High values of  $R_S$  provide better accuracy at lower currents by minimizing the effects of offset, while low values of  $R_S$  minimize voltage loss in the supply line. For most applications, using an  $R_S$  value that provides a full-scale shunt voltage range of 50 mV to 100 mV results in the best performance. Maximum input voltage for accurate measurements is 500 mV, but output voltage is limited by supply.

### 7.3.3 Comparator

The INA200, INA201, and INA202 devices incorporate an open-drain comparator. This comparator typically has 2 mV of offset and a 1.3- $\mu$ s (typical) response time. The output of the comparator latches and is reset through the  $\overline{\text{RESET}}$  pin; see [图 28](#).

When  $V_S$  and  $\overline{\text{RESET}}$  are different, TI recommends adding a low-pass filter (LPF) on the  $\overline{\text{RESET}}$  pin to avoid comparator behavior inconsistent with the data sheet. For instance, with a 12-V supply and a 3.3-V  $\overline{\text{RESET}}$ , a rise time of 400 ns is appropriate. Similarly, with an 18-V supply and a 2.7-V  $\overline{\text{RESET}}$ , a 1- $\mu$ s rise time is appropriate; see [图 31](#).

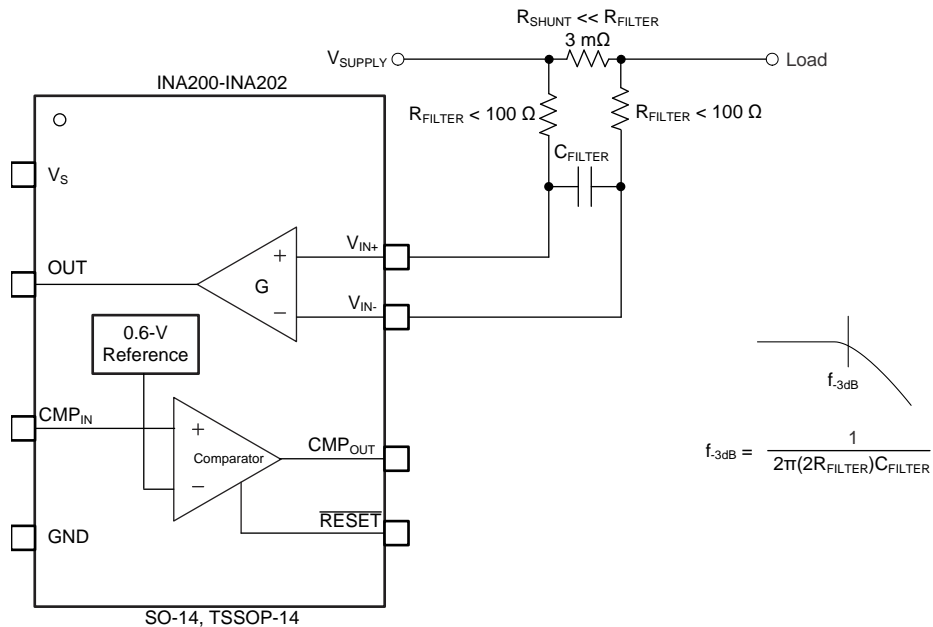

Copyright © 2017, Texas Instruments Incorporated

图 27. Input Filter (Gain Error: 1.5% to 2.8%)



图 28. Comparator Latching Capability



Copyright © 2017, Texas Instruments Incorporated

- (1)  $Q_1$  cascodes the comparator output to drive a high-side FET (the 2N3904 shown is good up to 60 V). The shunt can be located in any one of the three locations shown. The latching capability must be used in shutdown applications to prevent oscillation at the trip point.

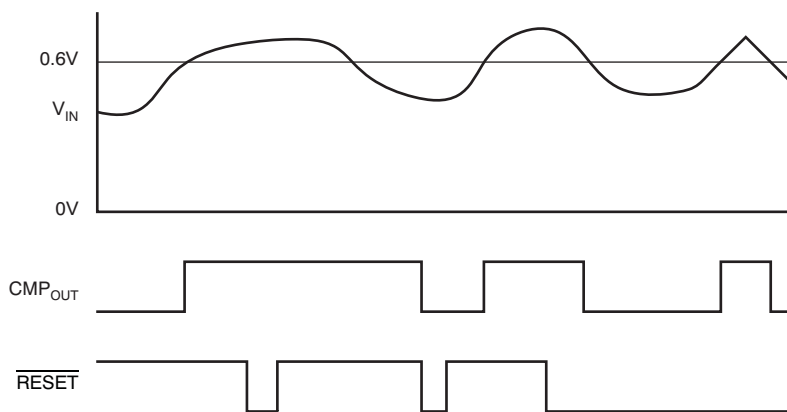
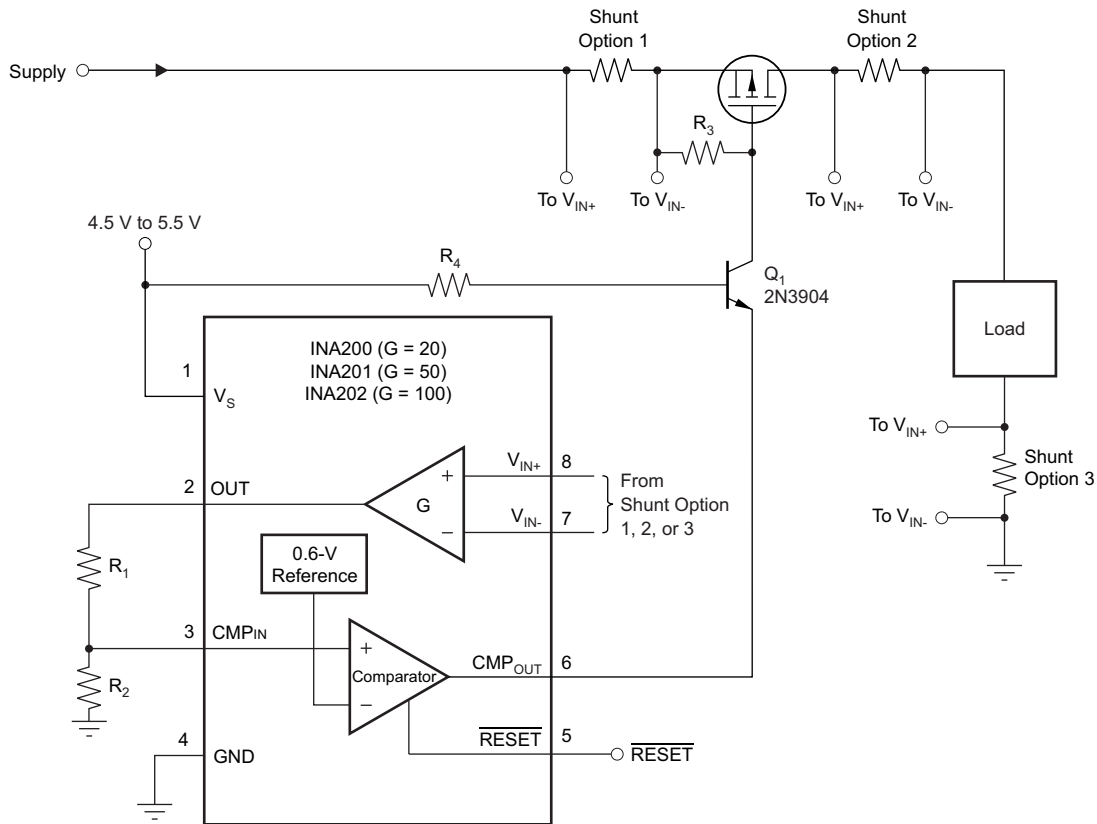
**图 29. High-Side Switch Overcurrent Shutdown**





Copyright © 2017, Texas Instruments Incorporated

- (1) It is possible to set different limits for each direction.

图 30. Bidirectional Overcurrent Comparator

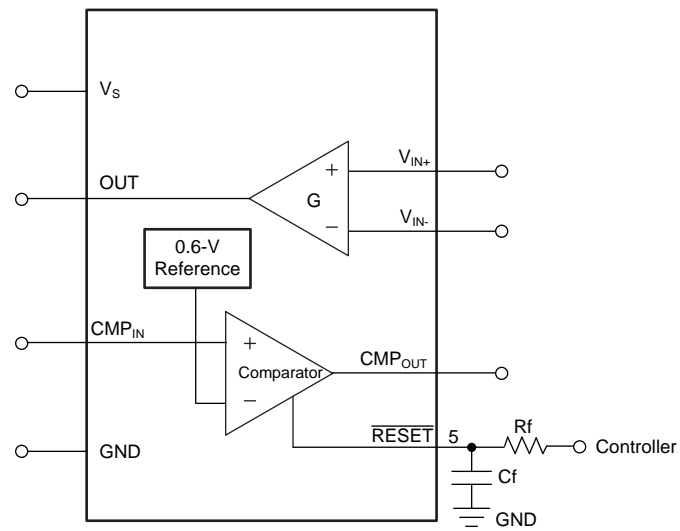

**图 31. Filter on  $\overline{RESET}$  Pin**

## 7.4 Device Functional Modes

### 7.4.1 Input Filtering

An obvious and straightforward location for filtering is at the output of the INA20x series; however, this location negates the advantage of the low output impedance of the internal buffer. The only other option for filtering is at the input pins of the INA20x devices, which is complicated by the internal 5 kΩ + 30% input impedance. This is shown in [图 27](#). Using the lowest possible resistor values minimizes the initial shift in gain and effects of tolerance. The effect on initial gain is shown in [公式 1](#):

$$\text{Gain Error \%} = 100 - \left[ 100 \times \frac{5\text{k}\Omega}{5\text{k}\Omega + R_{\text{FILT}}} \right] \quad (1)$$

Total effect on gain error can be calculated by replacing the 5-kΩ term with 5 kΩ – 30%, (or 3.5 kΩ) or 5 kΩ + 30% (or 6.5 kΩ). The tolerance extremes of R<sub>FILT</sub> can be inserted into the equation. If a pair of 100-Ω 1% resistors are used on the inputs, the initial gain error equals 1.96%. Worst-case tolerance conditions always occur at the lower excursion of the internal 5-kΩ resistor (3.5 kΩ), and the higher excursion of R<sub>FILT</sub> – 3% in this case.

The specified accuracy of the INA20x devices must then be combined in addition to these tolerances. While this discussion treated accuracy worst-case conditions by combining the extremes of the resistor values, it is appropriate to use geometric mean or root sum square calculations to total the effects of accuracy variations.

### 7.4.2 Accuracy Variations as a Result of V<sub>SENSE</sub> and Common-Mode Voltage

The accuracy of the INA200, INA201, and INA202 current shunt monitors is a function of two main variables: V<sub>SENSE</sub> (V<sub>IN+</sub> – V<sub>IN-</sub>), common-mode voltage, (V<sub>CM</sub>), relative to the supply voltage (V<sub>S</sub>). V<sub>CM</sub> is expressed as (V<sub>IN+</sub> + V<sub>IN-</sub>) / 2; however, in practice, V<sub>CM</sub> is seen as the voltage at V<sub>IN+</sub> because the voltage drop across V<sub>SENSE</sub> is typically small.

This section addresses the accuracy of these specific operating regions:

- Normal Case 1: V<sub>SENSE</sub> ≥ 20 mV, V<sub>CM</sub> ≥ V<sub>S</sub>
- Normal Case 2: V<sub>SENSE</sub> ≥ 20 mV, V<sub>CM</sub> < V<sub>S</sub>
- Low V<sub>SENSE</sub> Case 1: V<sub>SENSE</sub> < 20 mV, –16 V ≤ V<sub>CM</sub> < 0
- Low V<sub>SENSE</sub> Case 2: V<sub>SENSE</sub> < 20 mV, 0 V ≤ V<sub>CM</sub> ≤ V<sub>S</sub>
- Low V<sub>SENSE</sub> Case 3: V<sub>SENSE</sub> < 20 mV, V<sub>S</sub> < V<sub>CM</sub> ≤ 80 V

#### 7.4.2.1 Normal Case 1: V<sub>SENSE</sub> ≥ 20 mV, V<sub>CM</sub> ≥ V<sub>S</sub>

This region of operation provides the highest accuracy. Here, the input offset voltage is characterized and measured using a two-step method. First, the gain is determined by [公式 2](#).

$$G = \frac{V_{\text{OUT1}} - V_{\text{OUT2}}}{100\text{mV} - 20\text{mV}}$$

where

- V<sub>OUT1</sub> = output voltage with V<sub>SENSE</sub> = 100 mV
  - V<sub>OUT2</sub> = output voltage with V<sub>SENSE</sub> = 20 mV
- (2)

Then the offset voltage is measured at V<sub>SENSE</sub> = 100 mV, and referred to the input (RTI) of the current shunt monitor, as shown in [Electrical Characteristics: Current-Shunt Monitor](#).

$$V_{\text{OSRTI}} (\text{Referred-To-Input}) = \left[ \frac{V_{\text{OUT1}}}{G} \right] - 100\text{mV} \quad (3)$$

In the [Typical Characteristics](#), [图 7](#) shows the highest accuracy for the this region of operation. In this plot, V<sub>S</sub> = 12 V. For V<sub>CM</sub> ≥ 12 V, the output error is at the minimum value. This case creates the V<sub>SENSE</sub> ≥ 20-mV output specifications in [Electrical Characteristics: Current-Shunt Monitor](#).

**Device Functional Modes (接下页)**
**7.4.2.2 Normal Case 2:  $V_{SENSE} \geq 20\text{ mV}$ ,  $V_{CM} < V_S$** 

This region of operation is less accurate than normal case 1 as a result of the common-mode operating area in which the part functions, as shown in the 图 7 curve (图 7). As noted, for this graph  $V_S = 12\text{ V}$ ; for  $V_{CM} < 12\text{ V}$ , the output error increases as  $V_{CM}$  decreases to less than  $12\text{ V}$ , with a typical maximum error of 0.005% at the most negative  $V_{CM} = -16\text{ V}$ .

**7.4.2.3 Low  $V_{SENSE}$  Case 1:  $V_{SENSE} < 20\text{ mV}$ ,  $-16\text{ V} \leq V_{CM} < 0$   
and Low  $V_{SENSE}$  Case 3:  $V_{SENSE} < 20\text{ mV}$ ,  $V_S < V_{CM} \leq 80\text{ V}$** 

Although the INA200 family of devices are not designed for accurate operation in these regions, some applications are exposed to these conditions. For example, when monitoring power supplies that are switched on and off while  $V_S$  is still applied to the INA20x devices, it is important to know what the behavior of the devices is in these regions.

As  $V_{SENSE}$  approaches  $0\text{ mV}$ , in these  $V_{CM}$  regions, the accuracy of the device output degrades. A larger-than-normal offset can appear at the current shunt monitor output with a typical maximum value of  $V_{OUT} = 300\text{ mV}$  for  $V_{SENSE} = 0\text{ mV}$ . As  $V_{SENSE}$  approaches  $20\text{ mV}$ ,  $V_{OUT}$  returns to the expected output value with accuracy as shown in [Electrical Characteristics: Current-Shunt Monitor](#). 图 32 shows this effect using the INA202 (gain = 100).



图 32. Example For Low  $V_{SENSE}$  Cases 1 and 3 (INA202, Gain = 100)

**7.4.2.4 Low  $V_{SENSE}$  Case 2:  $V_{SENSE} < 20\text{ mV}$ ,  $0\text{ V} \leq V_{CM} \leq V_S$** 

This region of operation is the least accurate for the INA20x family. To achieve the wide input common-mode voltage range, these devices use two op amp front ends in parallel. One op amp front end operates in the positive input common-mode voltage range, and the other in the negative input region. For this case, neither of these two internal amplifiers dominates and overall loop gain is low. Within this region,  $V_{OUT}$  approaches voltages close to linear operation levels for normal case 2. This deviation from linear operation becomes greatest the closer  $V_{SENSE}$  approaches  $0\text{ V}$ . Within this region, as  $V_{SENSE}$  approaches  $20\text{ mV}$ , device operation is closer to that is described in normal case 2. 图 33 shows this behavior for the INA202. The  $V_{OUT}$  maximum peak for this case is tested by maintaining a constant  $V_S$ , setting  $V_{SENSE}$  equal to  $0\text{ mV}$  and sweeping  $V_{CM}$  from  $0\text{ V}$  to  $V_S$ . The exact  $V_{CM}$  at which  $V_{OUT}$  peaks during this test varies from device to device, but the  $V_{OUT}$  maximum peak is tested to be less than the specified  $V_{OUT}$  tested limit.

Device Functional Modes (接下页)

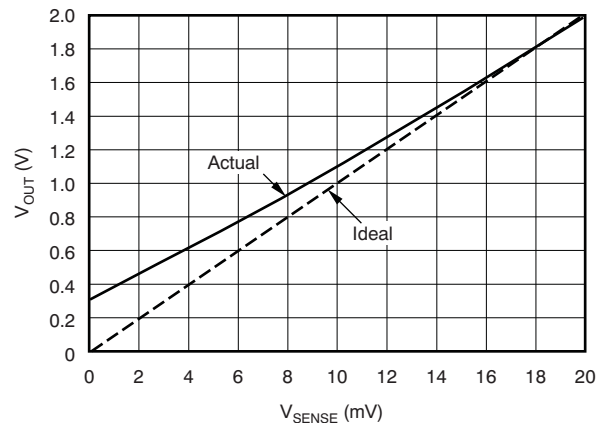
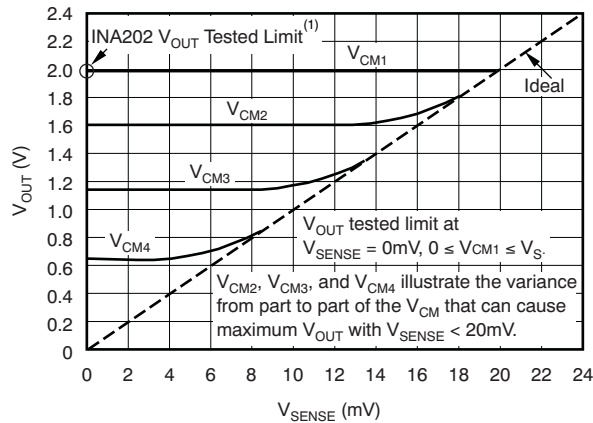

NOTE: (1) INA200  $V_{OUT}$  Tested Limit = 0.4V. INA201  $V_{OUT}$  Tested Limit = 1V.

图 33. Example For Low  $V_{SENSE}$  Case 2 (INA202, Gain = 100)

7.4.3 Transient Protection

The -16 to 80 V common-mode range of the INA20x devices is ideal for withstanding automotive fault conditions ranging from 12-V battery reversal up to 80-V transients, since no additional protective components are required up to those levels. In the event that the INA20x devices are exposed to transients on the inputs in excess of their ratings, then external transient absorption with semiconductor transient absorbers (such as Zeners) are required. TI does not recommend using MOVs or VDRs, except when they are used in addition to a semiconductor transient absorber. Select the transient absorber so the absorber does not allow the INA20x devices to be exposed to transients greater than 80 V (that is, allow for transient absorber tolerance and additional voltage due to transient absorber dynamic impedance). Despite the use of internal Zener-type ESD protection, the INA20x devices do not lend themselves to using external resistors in series with the inputs since the internal gain resistors can vary up to  $\pm 30\%$ . (If gain accuracy is not important, then resistors can be added in series with the INA200, INA201, and INA202 inputs with two equal resistors on each input.)

7.4.4 Output Voltage Range

The output of the INA20x devices is accurate within the output voltage swing range set by the power supply pin ( $V_S$ .) This performance is best illustrated when using the INA202 (a gain of 100 version), where a 100-mV full-scale input from the shunt resistor requires an output voltage swing of 10 V, and a power-supply voltage sufficient to achieve 10 V on the output.

## 8 Application and Implementation

### 注

Information in the following applications sections is not part of the TI component specification, and TI does not warrant its accuracy or completeness. TI's customers are responsible for determining suitability of components for their purposes. Customers should validate and test their design implementation to confirm system functionality.

### 8.1 Application Information

The INA20x series is designed to enable simple configuration for detecting overcurrent conditions and current monitoring in an application. This device is individually targeted towards overcurrent detection of a single threshold. However, this device can pair with additional devices and circuitry to create more complex monitoring functional blocks.

### 8.2 Typical Application

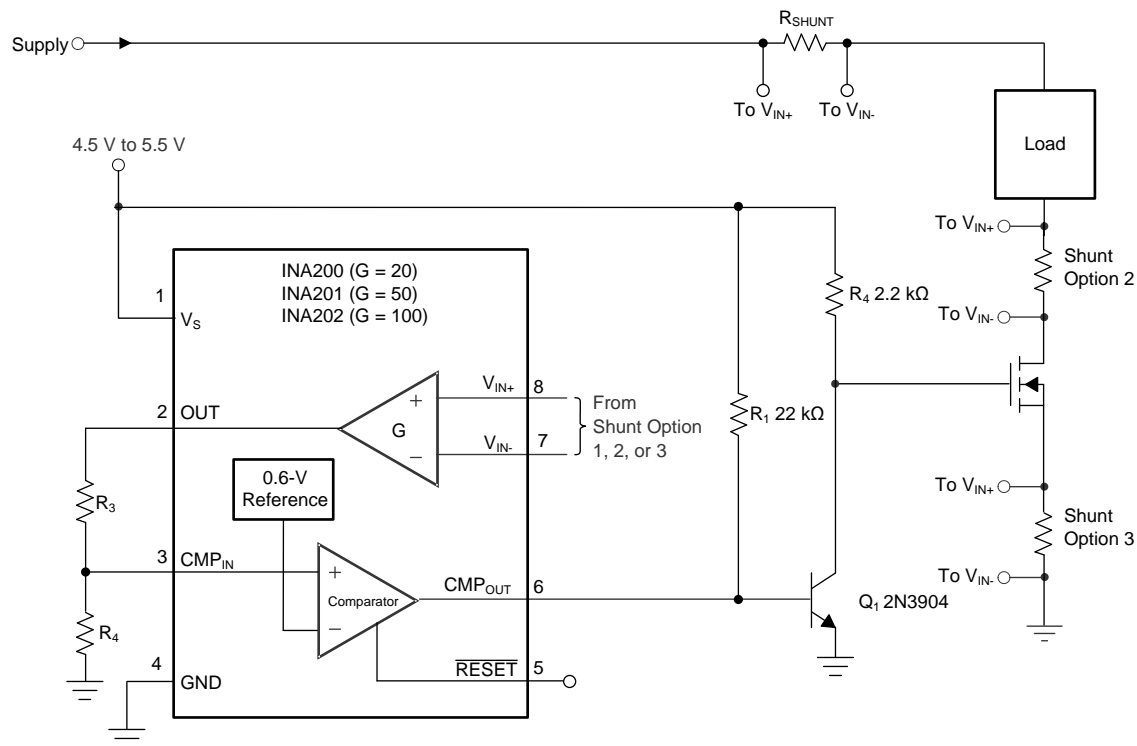

Copyright © 2017, Texas Instruments Incorporated

(1) In this case, Q1 inverts the comparator output.

**图 34. Low-Side Switch Overcurrent Shutdown**

#### 8.2.1 Design Requirements

The device measures current through a resistive shunt with current flowing in one direction that enables detection of an overcurrent event only when the differential input voltage exceeds the threshold limit. When the current reaches the set limit of the divider  $R_1 / R_2$ , the output of  $CMP_{OUT}$  transitions high, which turns Q1 on, pulls the gate of the pass-FET low, and turns off the flow off current.

## Typical Application (接下页)

### 8.2.2 Detailed Design Procedure

图 34 显示了设备的基本连接。输入端子 (IN+ 和 IN -) 必须尽可能紧密地连接到电流 sensing 电阻，以最小化与分流电阻串联的任何电阻。分流电阻和输入端子之间的额外电阻会导致测量误差。当输入电流流经此外部输入电阻时，分流电阻上产生的电压与到达输入端子的电压不同。

使用 INA20x 的增益和分流值来计算所需的 trip 电流的 OUT 电压。配置 R1 和 R2 使得电流 trip 点等于 0.6-V 参考电压。

### 8.2.3 Application Curve



图 35. Low-Side Switch Overcurrent Shutdown Response

## 9 Power Supply Recommendations

The input circuitry of the INA20x devices can accurately measure beyond the power-supply voltage,  $V_s$ . For example, the  $V_s$  power supply is 5 V, whereas the load power-supply voltage is up to 80 V. However, the output voltage range of the OUT pin is limited by the voltages on the power supply pin.

### 9.1 Output vs Supply Ramp Considerations

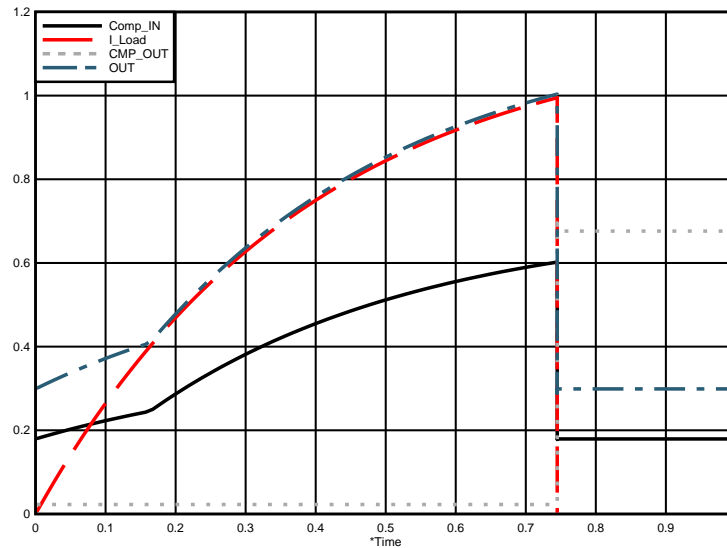
图 36, 图 37, 和 图 38 显示了典型输出电压，用于高边和低边配置，具有给定的 ramp 电源电压。这些在电源启动期间输出上的波动可能需要控制器 incorporate 一个 blanking time 来忽略这些 artifacts。

Output vs Supply Ramp Considerations (接下页)



图 36. Analog Output vs Supply Ramp (INA200)



图 37. Analog Output vs Supply Ramp (INA201)

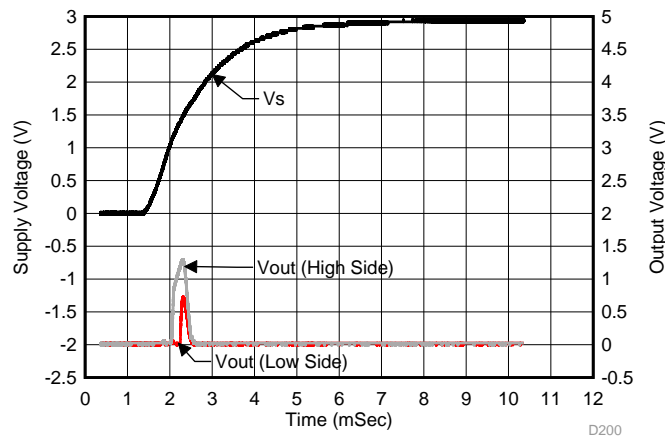

图 38. Analog Output vs Supply Ramp (INA202)

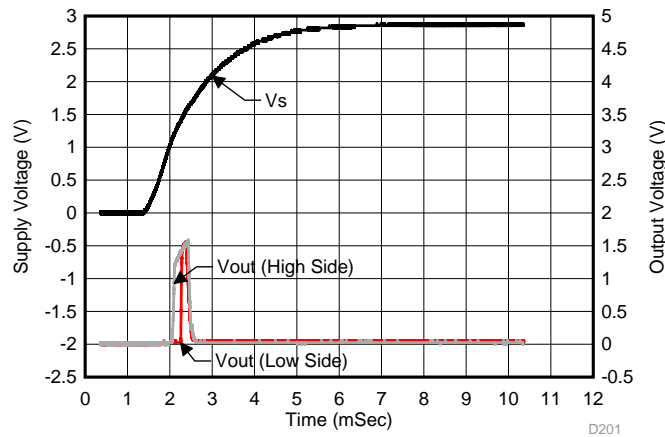

## 10 Layout

### 10.1 Layout Guidelines

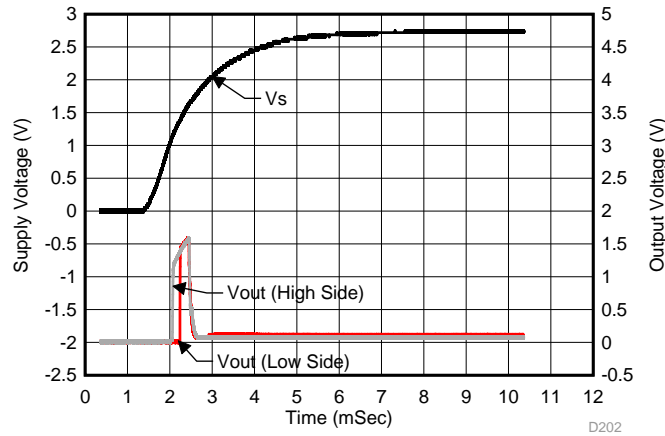
- Connect the input pins to the sensing resistor using a Kelvin or 4-wire connection. This connection technique ensures that only the current-sensing resistor impedance is detected between the input pins. Poor routing of the current-sensing resistor commonly results in additional resistance present between the input pins. Given the very-low-ohmic value of the current resistor, any additional high-current carrying impedance causes significant measurement errors.
- The power-supply bypass capacitor must be placed as close as possible to the supply and ground pins. The recommended value of this bypass capacitor is 0.1  $\mu\text{F}$ . Additional decoupling capacitance can be added to compensate for noisy or high-impedance power supplies.

### 10.2 Layout Example



图 39. INA20x Layout Example

## 11 器件和文档支持

### 11.1 相关链接

下面的表格列出了快速访问链接。类别包括技术文档、支持与社区资源、工具和软件，以及申请样片或购买产品的快速链接。

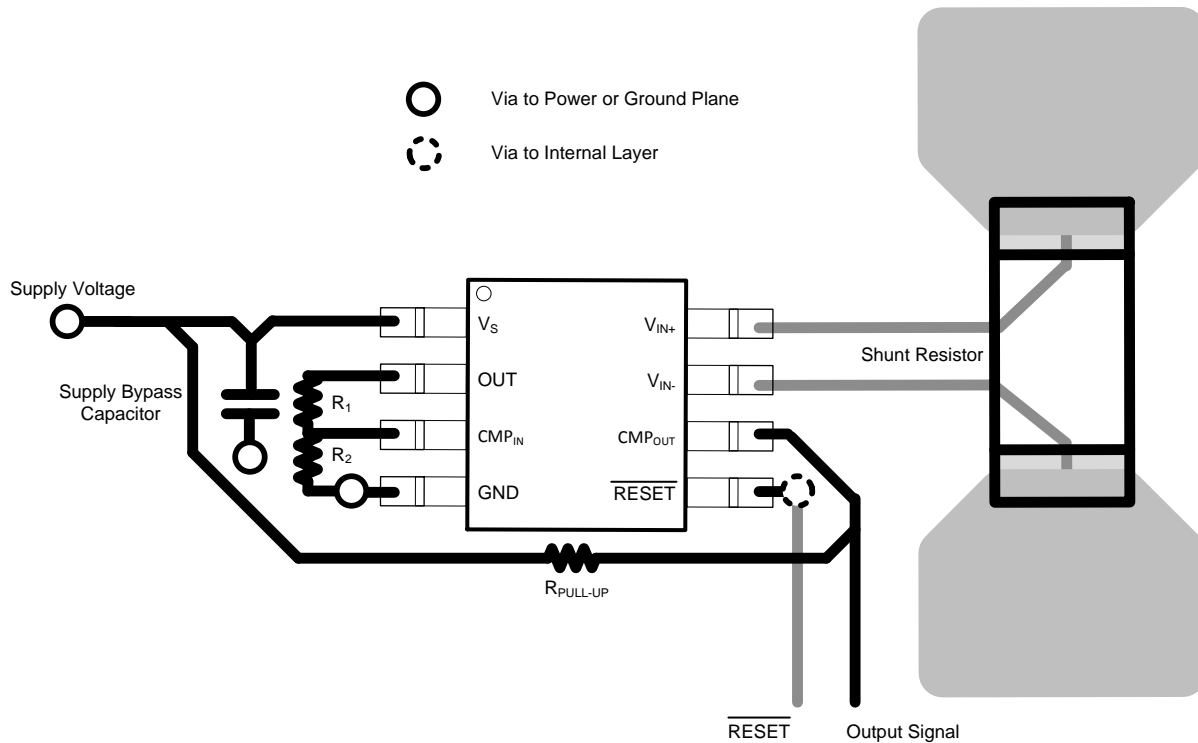
表 1. 相关链接

器件	产品文件夹	立即订购	技术文档	工具和软件	支持和社区
INA200	<a href="#">请单击此处</a>	<a href="#">请单击此处</a>	<a href="#">请单击此处</a>	<a href="#">请单击此处</a>	<a href="#">请单击此处</a>
INA201	<a href="#">请单击此处</a>	<a href="#">请单击此处</a>	<a href="#">请单击此处</a>	<a href="#">请单击此处</a>	<a href="#">请单击此处</a>
INA202	<a href="#">请单击此处</a>	<a href="#">请单击此处</a>	<a href="#">请单击此处</a>	<a href="#">请单击此处</a>	<a href="#">请单击此处</a>

### 11.2 社区资源

下列链接提供到 TI 社区资源的连接。链接的内容由各个分销商“按照原样”提供。这些内容并不构成 TI 技术规范，并且不一定反映 TI 的观点；请参阅 TI 的《使用条款》。

**TI E2E™ 在线社区** *TI 的工程师对工程师 (E2E) 社区*。此社区的创建目的在于促进工程师之间的协作。在 [e2e.ti.com](http://e2e.ti.com) 中，您可以咨询问题、分享知识、拓展思路并与同行工程师一道帮助解决问题。

**设计支持** *TI 参考设计支持* 可帮助您快速查找有帮助的 E2E 论坛、设计支持工具以及技术支持的联系信息。

### 11.3 商标

E2E is a trademark of Texas Instruments.

All other trademarks are the property of their respective owners.

### 11.4 静电放电警告



这些装置包含有限的内置 ESD 保护。存储或装卸时，应将导线一起截短或将装置放置于导电泡棉中，以防止 MOS 门极遭受静电损伤。

### 11.5 Glossary

**SLYZ022** — *TI Glossary*.

This glossary lists and explains terms, acronyms, and definitions.

## 12 机械、封装和可订购信息

以下页面包含机械、封装和可订购信息。这些信息是指定器件的最新可用数据。这些数据如有变更，恕不另行通知和修订此文档。如欲获取此数据表的浏览器版本，请参阅左侧的导航。

**PACKAGING INFORMATION**

Orderable Device	Status (1)	Package Type	Package Drawing	Pins	Package Qty	Eco Plan (2)	Lead finish/ Ball material (6)	MSL Peak Temp (3)	Op Temp (°C)	Device Marking (4/5)	Samples
INA200AID	ACTIVE	SOIC	D	8	75	RoHS & Green	NIPDAU	Level-2-260C-1 YEAR	-40 to 125	INA 200A	<a href="#">Samples</a>
INA200AIDGKR	ACTIVE	VSSOP	DGK	8	2500	RoHS & Green	NIPDAUAG	Level-2-260C-1 YEAR	-40 to 125	BQH	<a href="#">Samples</a>
INA200AIDGKRG4	ACTIVE	VSSOP	DGK	8	2500	RoHS & Green	NIPDAUAG	Level-2-260C-1 YEAR	-40 to 125	BQH	<a href="#">Samples</a>
INA200AIDGKT	ACTIVE	VSSOP	DGK	8	250	RoHS & Green	NIPDAUAG	Level-2-260C-1 YEAR	-40 to 125	BQH	<a href="#">Samples</a>
INA200AIDGKTG4	ACTIVE	VSSOP	DGK	8	250	RoHS & Green	NIPDAUAG	Level-2-260C-1 YEAR	-40 to 125	BQH	<a href="#">Samples</a>
INA200AIDR	ACTIVE	SOIC	D	8	2500	RoHS & Green	NIPDAU	Level-2-260C-1 YEAR	-40 to 125	INA 200A	<a href="#">Samples</a>
INA201AID	ACTIVE	SOIC	D	8	75	RoHS & Green	NIPDAU	Level-2-260C-1 YEAR	-40 to 125	INA 201A	<a href="#">Samples</a>
INA201AIDGKR	ACTIVE	VSSOP	DGK	8	2500	RoHS & Green	Call TI   NIPDAUAG   NIPDAU	Level-2-260C-1 YEAR	-40 to 125	BQJ	<a href="#">Samples</a>
INA201AIDGKT	ACTIVE	VSSOP	DGK	8	250	RoHS & Green	Call TI   NIPDAUAG   NIPDAU	Level-2-260C-1 YEAR	-40 to 125	BQJ	<a href="#">Samples</a>
INA201AIDR	ACTIVE	SOIC	D	8	2500	RoHS & Green	NIPDAU	Level-2-260C-1 YEAR	-40 to 125	INA 201A	<a href="#">Samples</a>
INA202AID	ACTIVE	SOIC	D	8	75	RoHS & Green	NIPDAU	Level-2-260C-1 YEAR	-40 to 125	INA 202A	<a href="#">Samples</a>
INA202AIDGKR	ACTIVE	VSSOP	DGK	8	2500	RoHS & Green	Call TI   NIPDAUAG   NIPDAU	Level-2-260C-1 YEAR	-40 to 125	BQL	<a href="#">Samples</a>
INA202AIDGKT	ACTIVE	VSSOP	DGK	8	250	RoHS & Green	Call TI   NIPDAUAG   NIPDAU	Level-2-260C-1 YEAR	-40 to 125	BQL	<a href="#">Samples</a>
INA202AIDR	ACTIVE	SOIC	D	8	2500	RoHS & Green	NIPDAU	Level-2-260C-1 YEAR	-40 to 125	INA 202A	<a href="#">Samples</a>

(1) The marketing status values are defined as follows:

**ACTIVE:** Product device recommended for new designs.

**LIFEBUY:** TI has announced that the device will be discontinued, and a lifetime-buy period is in effect.

**NRND:** Not recommended for new designs. Device is in production to support existing customers, but TI does not recommend using this part in a new design.

**PREVIEW:** Device has been announced but is not in production. Samples may or may not be available.

**OBSELETE:** TI has discontinued the production of the device.

(2) **RoHS:** TI defines "RoHS" to mean semiconductor products that are compliant with the current EU RoHS requirements for all 10 RoHS substances, including the requirement that RoHS substance do not exceed 0.1% by weight in homogeneous materials. Where designed to be soldered at high temperatures, "RoHS" products are suitable for use in specified lead-free processes. TI may reference these types of products as "Pb-Free".

**RoHS Exempt:** TI defines "RoHS Exempt" to mean products that contain lead but are compliant with EU RoHS pursuant to a specific EU RoHS exemption.

**Green:** TI defines "Green" to mean the content of Chlorine (Cl) and Bromine (Br) based flame retardants meet JS709B low halogen requirements of <=1000ppm threshold. Antimony trioxide based flame retardants must also meet the <=1000ppm threshold requirement.

(3) **MSL, Peak Temp.** - The Moisture Sensitivity Level rating according to the JEDEC industry standard classifications, and peak solder temperature.

(4) There may be additional marking, which relates to the logo, the lot trace code information, or the environmental category on the device.

(5) Multiple Device Markings will be inside parentheses. Only one Device Marking contained in parentheses and separated by a "~" will appear on a device. If a line is indented then it is a continuation of the previous line and the two combined represent the entire Device Marking for that device.

(6) **Lead finish/Ball material** - Orderable Devices may have multiple material finish options. Finish options are separated by a vertical ruled line. Lead finish/Ball material values may wrap to two lines if the finish value exceeds the maximum column width.

**Important Information and Disclaimer:**The information provided on this page represents TI's knowledge and belief as of the date that it is provided. TI bases its knowledge and belief on information provided by third parties, and makes no representation or warranty as to the accuracy of such information. Efforts are underway to better integrate information from third parties. TI has taken and continues to take reasonable steps to provide representative and accurate information but may not have conducted destructive testing or chemical analysis on incoming materials and chemicals. TI and TI suppliers consider certain information to be proprietary, and thus CAS numbers and other limited information may not be available for release.

In no event shall TI's liability arising out of such information exceed the total purchase price of the TI part(s) at issue in this document sold by TI to Customer on an annual basis.

**OTHER QUALIFIED VERSIONS OF INA200, INA201, INA202 :**

- Automotive : [INA200-Q1](#), [INA201-Q1](#), [INA202-Q1](#)

NOTE: Qualified Version Definitions:

- Automotive - Q100 devices qualified for high-reliability automotive applications targeting zero defects

**TAPE AND REEL INFORMATION**

**QUADRANT ASSIGNMENTS FOR PIN 1 ORIENTATION IN TAPE**



\*All dimensions are nominal

Device	Package Type	Package Drawing	Pins	SPQ	Reel Diameter (mm)	Reel Width W1 (mm)	A0 (mm)	B0 (mm)	K0 (mm)	P1 (mm)	W (mm)	Pin1 Quadrant
INA200AIDGKR	VSSOP	DGK	8	2500	330.0	12.4	5.3	3.4	1.4	8.0	12.0	Q1
INA200AIDGKT	VSSOP	DGK	8	250	330.0	12.4	5.3	3.4	1.4	8.0	12.0	Q1
INA200AIDR	SOIC	D	8	2500	330.0	12.4	6.4	5.2	2.1	8.0	12.0	Q1
INA201AIDGKR	VSSOP	DGK	8	2500	330.0	12.4	5.3	3.4	1.4	8.0	12.0	Q1
INA201AIDGKR	VSSOP	DGK	8	2500	330.0	12.4	5.3	3.4	1.4	8.0	12.0	Q1
INA201AIDGKT	VSSOP	DGK	8	250	330.0	12.4	5.3	3.4	1.4	8.0	12.0	Q1
INA201AIDR	SOIC	D	8	2500	330.0	12.4	6.4	5.2	2.1	8.0	12.0	Q1
INA202AIDGKR	VSSOP	DGK	8	2500	330.0	12.4	5.3	3.4	1.4	8.0	12.0	Q1
INA202AIDGKR	VSSOP	DGK	8	2500	330.0	12.4	5.3	3.4	1.4	8.0	12.0	Q1
INA202AIDGKT	VSSOP	DGK	8	250	330.0	12.4	5.3	3.4	1.4	8.0	12.0	Q1
INA202AIDGKT	VSSOP	DGK	8	250	180.0	12.4	5.3	3.4	1.4	8.0	12.0	Q1
INA202AIDR	SOIC	D	8	2500	330.0	12.4	6.4	5.2	2.1	8.0	12.0	Q1

**TAPE AND REEL BOX DIMENSIONS**

\*All dimensions are nominal

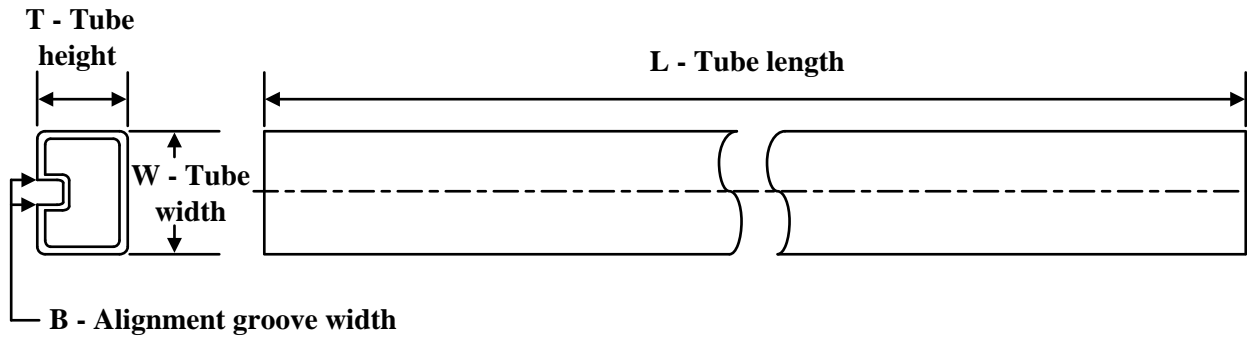
Device	Package Type	Package Drawing	Pins	SPQ	Length (mm)	Width (mm)	Height (mm)
INA200AIDGKR	VSSOP	DGK	8	2500	366.0	364.0	50.0
INA200AIDGKT	VSSOP	DGK	8	250	366.0	364.0	50.0
INA200AIDR	SOIC	D	8	2500	367.0	367.0	35.0
INA201AIDGKR	VSSOP	DGK	8	2500	366.0	364.0	50.0
INA201AIDGKR	VSSOP	DGK	8	2500	367.0	367.0	35.0
INA201AIDGKT	VSSOP	DGK	8	250	366.0	364.0	50.0
INA201AIDR	SOIC	D	8	2500	356.0	356.0	35.0
INA202AIDGKR	VSSOP	DGK	8	2500	366.0	364.0	50.0
INA202AIDGKR	VSSOP	DGK	8	2500	367.0	367.0	35.0
INA202AIDGKT	VSSOP	DGK	8	250	366.0	364.0	50.0
INA202AIDGKT	VSSOP	DGK	8	250	210.0	185.0	35.0
INA202AIDR	SOIC	D	8	2500	367.0	367.0	35.0

**TUBE**

\*All dimensions are nominal

Device	Package Name	Package Type	Pins	SPQ	L (mm)	W (mm)	T (μm)	B (mm)
INA200AID	D	SOIC	8	75	506.6	8	3940	4.32
INA201AID	D	SOIC	8	75	506.6	8	3940	4.32
INA202AID	D	SOIC	8	75	506.6	8	3940	4.32



D0008A

# PACKAGE OUTLINE

SOIC - 1.75 mm max height

SMALL OUTLINE INTEGRATED CIRCUIT



4214825/C 02/2019

### NOTES:

- Linear dimensions are in inches [millimeters]. Dimensions in parenthesis are for reference only. Controlling dimensions are in inches. Dimensioning and tolerancing per ASME Y14.5M.
- This drawing is subject to change without notice.
- This dimension does not include mold flash, protrusions, or gate burrs. Mold flash, protrusions, or gate burrs shall not exceed  $.006$  [0.15] per side.
- This dimension does not include interlead flash.
- Reference JEDEC registration MS-012, variation AA.



# EXAMPLE BOARD LAYOUT

D0008A

SOIC - 1.75 mm max height

SMALL OUTLINE INTEGRATED CIRCUIT



LAND PATTERN EXAMPLE  
 EXPOSED METAL SHOWN  
 SCALE:8X



SOLDER MASK DETAILS

4214825/C 02/2019

NOTES: (continued)

- 6. Publication IPC-7351 may have alternate designs.
- 7. Solder mask tolerances between and around signal pads can vary based on board fabrication site.

# EXAMPLE STENCIL DESIGN

D0008A

SOIC - 1.75 mm max height

SMALL OUTLINE INTEGRATED CIRCUIT



SOLDER PASTE EXAMPLE  
BASED ON .005 INCH [0.125 MM] THICK STENCIL  
SCALE:8X

4214825/C 02/2019

NOTES: (continued)

8. Laser cutting apertures with trapezoidal walls and rounded corners may offer better paste release. IPC-7525 may have alternate design recommendations.
9. Board assembly site may have different recommendations for stencil design.

DGK (S-PDSO-G8)

PLASTIC SMALL-OUTLINE PACKAGE



4073329/E 05/06

- NOTES:
- A. All linear dimensions are in millimeters.
  - B. This drawing is subject to change without notice.
  - C. Body length does not include mold flash, protrusions, or gate burrs. Mold flash, protrusions, or gate burrs shall not exceed 0.15 per end.
  - D. Body width does not include interlead flash. Interlead flash shall not exceed 0.50 per side.
  - E. Falls within JEDEC MO-187 variation AA, except interlead flash.



- NOTES:
- A. All linear dimensions are in millimeters.
  - B. This drawing is subject to change without notice.
  - C. Publication IPC-7351 is recommended for alternate designs.
  - D. Laser cutting apertures with trapezoidal walls and also rounding corners will offer better paste release. Customers should contact their board assembly site for stencil design recommendations. Refer to IPC-7525 for other stencil recommendations.
  - E. Customers should contact their board fabrication site for solder mask tolerances between and around signal pads.

## 重要声明和免责声明

TI“按原样”提供技术和可靠性数据（包括数据表）、设计资源（包括参考设计）、应用或其他设计建议、网络工具、安全信息和其他资源，不保证没有瑕疵且不做任何明示或暗示的担保，包括但不限于对适销性、某特定用途方面的适用性或不侵犯任何第三方知识产权的暗示担保。

这些资源可供使用 TI 产品进行设计的熟练开发人员使用。您将自行承担以下全部责任：(1) 针对您的应用选择合适的 TI 产品，(2) 设计、验证并测试您的应用，(3) 确保您的应用满足相应标准以及任何其他功能安全、信息安全、监管或其他要求。

这些资源如有变更，恕不另行通知。TI 授权您仅可将这些资源用于研发本资源所述的 TI 产品的应用。严禁对这些资源进行其他复制或展示。您无权使用任何其他 TI 知识产权或任何第三方知识产权。您应全额赔偿因在这些资源的使用中对 TI 及其代表造成的任何索赔、损害、成本、损失和债务，TI 对此概不负责。

TI 提供的产品受 [TI 的销售条款](#) 或 [ti.com](#) 上其他适用条款/TI 产品随附的其他适用条款的约束。TI 提供这些资源并不会扩展或以其他方式更改 TI 针对 TI 产品发布的适用的担保或担保免责声明。

TI 反对并拒绝您可能提出的任何其他或不同的条款。

邮寄地址：Texas Instruments, Post Office Box 655303, Dallas, Texas 75265

Copyright © 2023，德州仪器 (TI) 公司

## X-ON Electronics

Largest Supplier of Electrical and Electronic Components

*Click to view similar products for* [Current & Power Monitors & Regulators](#) *category:*

*Click to view products by* [Texas Instruments](#) *manufacturer:*

Other Similar products are found below :

[ZXCT1009QFTA](#) [ZXCT1080QE5TA](#) [ZXCT1081QE5TA](#) [NCP4353ASNT1G](#) [INA230AIDGST](#) [NCP45495XMNTWG](#) [ZDS1009TA](#)  
[ZXCT199C3DW-7](#) [ZXCT199B1DW-7](#) [ZXCT199B3DW-7](#) [LTC4151HMS#PBF](#) [MAX14723ATP+T](#) [MAX17525ATP+T](#) [ISL28022FRZ-T](#)  
[ZXCT1008QFTA](#) [EMC1704-2-AP-TR](#) [MAX14626ETT+T](#) [NCP361SNT1G](#) [STPM33TR](#) [ISL28023FR60Z](#) [ISL28022FUZ-T](#)  
[ZXCT1023DFGTA](#) [ADM1293-1BARUZ-RL7](#) [INA203AQPWRQ1](#) [ZXCT1084QE5TA](#) [STEF12EPUR](#) [INA282AQDGKRQ1](#) [INA203AIDR](#)  
[ADE9000ACPZ-RL](#) [INA250A2PWR](#) [ISL28022FRZ](#) [STPM34TR](#) [S-19682B10A-A8T1U4](#) [S-19682B20A-A8T1U4](#) [ACS71020KMABTR-](#)  
[030B3-SPI](#) [ACS71020KMABTR-090B3-I2C](#) [ACS71020KMABTR-015B5-SPI](#) [ACS71020KMABTR-030B3-I2C](#) [LT3092ETS8#TRMPBF](#)  
[LT3092ETS8#TRPBF](#) [LT3092ITS8#TRMPBF](#) [LT3092ITS8#TRPBF](#) [LT3092IST#PBF](#) [LT3092EST#TRPBF](#) [LTC4151IMS#TRPBF](#)  
[LTC2945IMS#PBF](#) [LTC2945CMS#PBF](#) [LT3092EDD#PBF](#) [LTC2945HUD#PBF](#) [LTC2991IMS#PBF](#)