

具有 70V 总线故障保护功能和灵活数据速率的 ISO1042-Q1 汽车隔离式 CAN 收发器

1 特性

- 符合面向汽车应用的 AEC Q100 标准
- 等级 1: -40°C 至 125°C 的环境温度范围
- 符合 ISO 11898-2:2016 和 ISO 11898-5:2007 物理层标准
- 支持经典的最高 1Mbps CAN 和最高 5Mbps FD (灵活数据速率)
- 低环路延迟: 152ns
- 保护功能
 - 直流总线故障保护电压: $\pm 70\text{V}$
 - 总线引脚的 HBM ESD 容差: $\pm 16\text{kV}$
 - 驱动器显性超时 (TXD DTO)
 - V_{CC1} 和 V_{CC2} 欠压保护
- 共模电压范围: $\pm 30\text{V}$
- 未上电时的理想无源、高阻抗总线终端
- 高 CMTI: $100\text{kV}/\mu\text{s}$
- V_{CC1} 电压范围: 1.71V 至 5.5V
 - 支持连接到 CAN 控制器的 1.8V、2.5V、3.3V 和 5.0V 逻辑接口
- V_{CC2} 电压范围: 4.5V 至 5.5V
- 优异的电磁兼容性 (EMC)
 - 系统级 ESD、EFT 和浪涌抗扰性
 - 低辐射
- 16-SOIC 和 8-SOIC 封装选项
- 可用的工业版本: [ISO1042](#)
- 安全相关认证:
 - 符合 DIN VDE V 0884-11:2017-01 标准的 $7071\text{V}_{\text{PK}} V_{\text{IOTM}}$ 和 $1500\text{V}_{\text{PK}} V_{\text{IORM}}$ (增强型和基本型选项)
 - UL 1577 标准下, 长达 1 分钟的 $5000\text{V}_{\text{RMS}}$ 隔离
 - CQC、TUV 和 CSA 认证

2 应用

- 起动机/发电机
- 电池管理系统 (BMS)
- 直流/直流转换器
- 板载充电器 (OBC) 和无线充电器
- 逆变器和电机控制

3 说明

ISO1042-Q1 器件是一款符合 ISO11898-2 (2016) 标准规格的电隔离控制器局域网 (CAN) 收发器。ISO1042-Q1 器件提供 $\pm 70\text{V}$ 直流总线故障保护功能和 $\pm 30\text{V}$ 共模电压范围。该器件在 CAN FD 模式下最高支持 5Mbps 数据速率, 与经典 CAN 相比可实现更为快速的载荷传输。该器件采用二氧化硅 (SiO_2) 绝缘隔栅, 可承受 $5000\text{V}_{\text{RMS}}$ 的电压和 $1060\text{V}_{\text{RMS}}$ 的工作电压。电磁兼容性得到了显著增强, 可实现系统级 ESD、EFT 和浪涌并符合辐射标准。与隔离式电源一起使用, 此器件可抵御高电压冲击, 并防止总线的噪声电流进入本地接地。ISO1042-Q1 器件可用于基础型和增强型隔离 (请参阅 [增强型和基础型隔离选项](#))。ISO1042-Q1 器件支持 -40°C 至 $+125^{\circ}\text{C}$ 的宽环境温度范围。该器件可采用 SOIC-16 (DW) 和更为小巧的 SOIC-8 (DWV) 封装。

器件信息(1)

器件型号	封装	封装尺寸 (标称值)
ISO1042-Q1	SOIC (8)	5.85mm x 7.50mm
	SOIC (16)	10.30mm x 7.50mm

(1) 如需了解所有可用封装, 请参阅数据表末尾的可订购产品附录。

增强型和基础型隔离选项

特性	ISO1042x-Q1	ISO1042Bx-Q1
保护级别	加强版	基础版
浪涌测试电压	$10000\text{V}_{\text{PK}}$	6000V_{PK}
隔离额定值	$5000\text{V}_{\text{RMS}}$	$5000\text{V}_{\text{RMS}}$
工作电压	$1060\text{V}_{\text{RMS}}/1500\text{V}_{\text{PK}}$	$1060\text{V}_{\text{RMS}}/1500\text{V}_{\text{PK}}$

703A I2C

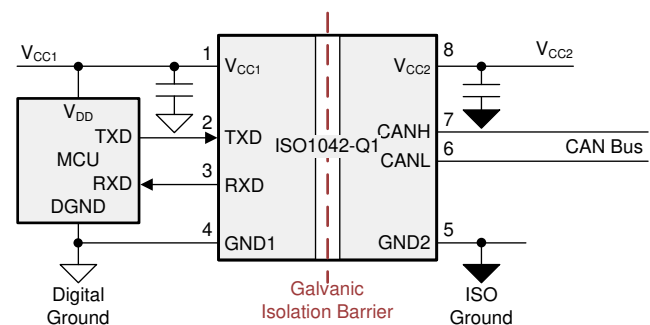

目录

1	特性	1	8	Detailed Description	19
2	应用	1	8.1	Overview	19
3	说明	1	8.2	Functional Block Diagram	19
4	修订历史记录	2	8.3	Feature Description	19
5	Pin Configuration and Functions	3	8.4	Device Functional Modes	23
6	Specifications	5	9	Application and Implementation	24
6.1	Absolute Maximum Ratings	5	9.1	Application Information	24
6.2	ESD Ratings	5	9.2	Typical Application	24
6.3	Transient Immunity	5	10	Power Supply Recommendations	27
6.4	Recommended Operating Conditions	5	11	Layout	28
6.5	Thermal Information	6	11.1	Layout Guidelines	28
6.6	Power Ratings	6	11.2	Layout Example	28
6.7	Insulation Specifications	7	12	器件和文档支持	30
6.8	Safety-Related Certifications	8	12.1	文档支持	30
6.9	Safety Limiting Values	8	12.2	接收文档更新通知	30
6.10	Electrical Characteristics - DC Specification	9	12.3	社区资源	30
6.11	Switching Characteristics	11	12.4	商标	30
6.12	Insulation Characteristics Curves	12	12.5	静电放电警告	30
6.13	Typical Characteristics	13	12.6	Glossary	30
7	Parameter Measurement Information	15	13	机械、封装和可订购信息	30
7.1	Test Circuits	15			

4 修订历史记录

注：之前版本的页码可能与当前版本有所不同。

Changes from Original (October 2018) to Revision A	Page
• 已更改 更改了新的安全认证	1
• Changed pin 10 from NC to GND2	3
• Changed Safety Related Certifications section to include new safety certification	8

5 Pin Configuration and Functions

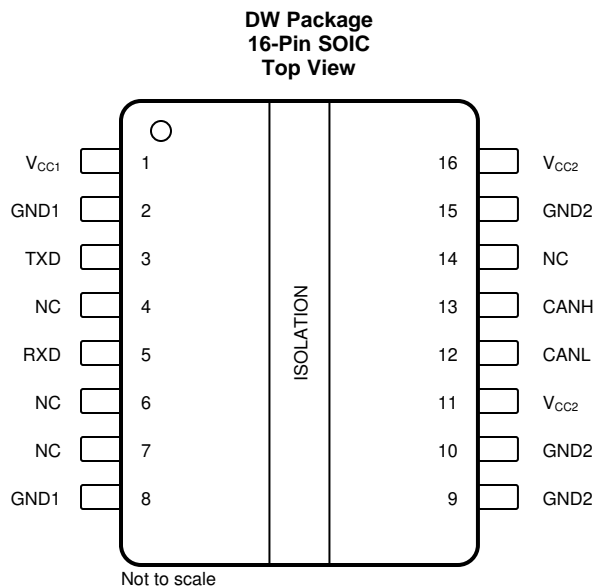

Pin Functions—16 Pins

PIN		I/O	DESCRIPTION
NO.	NAME		
1	V _{CC1}	—	Digital-side supply voltage, Side 1
2	GND1	—	Digital-side ground connection, Side 1
3	TXD	I	CAN transmit data input (LOW for dominant and HIGH for recessive bus states)
4	NC	—	Not connected
5	RXD	O	CAN receive data output (LOW for dominant and HIGH for recessive bus states)
6	NC	—	Not connected
7	NC	—	Not connected
8	GND1	—	Digital-side ground connection, Side 1
9	GND2	—	Transceiver-side ground connection, Side 2
10			
11	V _{CC2}	—	Transceiver-side supply voltage, Side 2. Must be externally connected to pin 16.
12	CANL	I/O	Low-level CAN bus line
13	CANH	I/O	High-level CAN bus line
14	NC	—	Not connected
15	GND2	—	Transceiver-side ground connection, Side 2
16	V _{CC2}	—	Transceiver-side supply voltage, Side 2. Must be externally connected to pin 11.

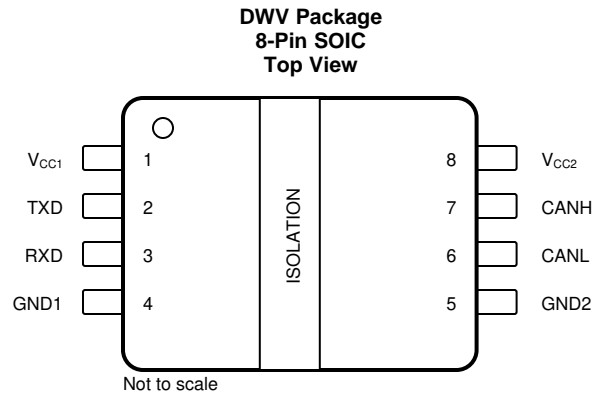

Pin Functions—8 Pins

PIN		I/O	DESCRIPTION
NO.	NAME		
1	V _{CC1}	—	Digital-side supply voltage, Side 1
2	TXD	I	CAN transmit data input (LOW for dominant and HIGH for recessive bus states)
3	RXD	O	CAN receive data output (LOW for dominant and HIGH for recessive bus states)
4	GND1	—	Digital-side ground connection, Side 1
5	GND2	—	Transceiver-side ground connection, Side 2
6	CANL	I/O	Low-level CAN bus line
7	CANH	I/O	High-level CAN bus line
8	V _{CC2}	—	Transceiver-side supply voltage, Side 2

6 Specifications

6.1 Absolute Maximum Ratings

Over operating free-air temperature range (unless otherwise noted)⁽¹⁾⁽²⁾

		MIN	MAX	UNIT
V _{CC1}	Supply voltage, side 1	-0.5	6	V
V _{CC2}	Supply voltage, side 2	-0.5	6	V
V _{IO}	Logic input and output voltage range (TXD and RXD)	-0.5	V _{CC1} +0.5 ⁽³⁾	V
I _O	Output current on RXD pin	-15	15	mA
V _{BUS}	Voltage on bus pins (CANH, CANL)	-70	70	V
V _{BUS_DIFF}	Differential voltage on bus pins (CANH-CANL)	-70	70	V
T _J	Junction temperature	-40	150	°C
T _{STG}	Storage temperature	-65	150	°C

- (1) Stresses beyond those listed under *Absolute Maximum Ratings* may cause permanent damage to the device. These are stress ratings only, which do not imply functional operation of the device at these or any other conditions beyond those indicated under *Recommended Operating Conditions*. Exposure to absolute-maximum-rated conditions for extended periods may affect device reliability.
- (2) All voltage values except differential I/O bus voltages are with respect to the local ground terminal (GND1 or GND2) and are peak voltage values.
- (3) Maximum voltage must not exceed 6 V

6.2 ESD Ratings

			VALUE	UNIT
V _(ESD)	Electrostatic discharge Human body model (HBM), per ANSI/ESDA/JEDEC JS-001	All pins ⁽¹⁾	±6000	V
		CANH and CANL to GND2 ⁽¹⁾	±16000	V
	Electrostatic discharge Charged device model (CDM), per JEDEC specification JESD22-C101	All pins ⁽²⁾	±1500	

- (1) JEDEC document JEP155 states that 500-V HBM allows safe manufacturing with a standard ESD control process.
- (2) JEDEC document JEP157 states that 250-V CDM allows safe manufacturing with a standard ESD control process.

6.3 Transient Immunity

	PARAMETER	TEST CONDITIONS	VALUE	UNIT
V _{PULSE}	ISO7637-2 Transients according to GIFT - ICT CAN EMC test specification	Pulse 1; CAN bus terminals (CANH, CANL) to GND2	-100	V
		Pulse 2; CAN bus terminals (CANH, CANL) to GND2	75	V
		Pulse 3a; CAN bus terminals (CANH, CANL) to GND2	-150	V
		Pulse 3b; CAN bus terminals (CANH, CANL) to GND2	100	V

6.4 Recommended Operating Conditions

		MIN	MAX	UNIT
V _{CC1}	Supply Voltage, Side 1, 1.8-V operation	1.71	1.89	V
	Supply Voltage, Side 1, 2.5-V, 3.3-V and 5.5-V operation	2.25	5.5	V
V _{CC2}	Supply Voltage, Side 2	4.5	5.5	V
T _A	Operating ambient temperature	-40	125	°C

6.5 Thermal Information

THERMAL METRIC ⁽¹⁾		ISO1042-Q1		UNIT
		DW (SOIC)	DWV (SOIC)	
		16 PINS	8 PINS	
R _{θJA}	Junction-to-ambient thermal resistance	69.9	100	°C/W
R _{θJC(top)}	Junction-to-case (top) thermal resistance	31.8	40.8	°C/W
R _{θJB}	Junction-to-board thermal resistance	29.0	51.8	°C/W
Ψ _{JT}	Junction-to-top characterization parameter	13.2	16.8	°C/W
Ψ _{JB}	Junction-to-board characterization parameter	28.6	49.8	°C/W
R _{θJC(bot)}	Junction-to-case (bottom) thermal resistance	-	-	°C/W

(1) For more information about traditional and new thermal metrics, see the [Semiconductor and IC Package Thermal Metrics](#) application report.

6.6 Power Ratings

PARAMETER		TEST CONDITIONS	MIN	TYP	MAX	UNIT
P _D	Maximum power dissipation (both sides)	See Figure 17 , V _{CC1} = V _{CC2} = 5.5 V, T _J = 150°C, R _L = 50 Ω, A repetitive pattern on TXD with 1 ms time period, 990 μs LOW time, and 10 μs HIGH time.			385	mW
P _{D1}	Maximum power dissipation (side-1)	See Figure 19 , V _{CC1} = V _{CC2} = 5.5 V, T _J = 150°C, R _L = 50 Ω, Input a 2-V pk-pk 2.5-MHz 50% duty cycle differential square wave on CANH-CANL			25	mW
P _{D2}	Maximum power dissipation (side-2)	See Figure 17 , V _{CC1} = V _{CC2} = 5.5 V, T _J = 150°C, R _L = 50 Ω, A repetitive pattern on TXD with 1 ms time period, 990 μs LOW time, and 10 μs HIGH time.			360	mW

6.7 Insulation Specifications

PARAMETER		TEST CONDITIONS	SPECIFICATIONS		UNIT
			DW-16	DWV-8	
IEC 60664-1					
CLR	External clearance ⁽¹⁾	Side 1 to side 2 distance through air	>8	>8.5	mm
CPG	External Creepage ⁽¹⁾	Side 1 to side 2 distance across package surface	>8	>8.5	mm
DTI	Distance through the insulation	Minimum internal gap (internal clearance)	>17	>17	µm
CTI	Comparative tracking index	IEC 60112; UL 746A	>600	>600	V
	Material Group	According to IEC 60664-1	I	I	
	Overvoltage category	Rated mains voltage ≤ 600 V _{RMS}	I-IV	I-IV	
		Rated mains voltage ≤ 1000 V _{RMS}	I-III	I-III	
DIN VDE V 0884-11:2017-01⁽²⁾					
V _{IORM}	Maximum repetitive peak isolation voltage	AC voltage (bipolar)	1500	1500	V _{PK}
V _{IOWM}	Maximum isolation working voltage	AC voltage (sine wave); time-dependent dielectric breakdown (TDDB) test;	1060	1060	V _{RMS}
		DC voltage	1500	1500	V _{DC}
V _{IOTM}	Maximum transient isolation voltage	V _{TEST} = V _{IOTM} , t = 60 s (qualification); V _{TEST} = 1.2 × V _{IOTM} , t = 1 s (100% production)	7071	7071	V _{PK}
V _{IOSM}	Maximum surge isolation voltage ISO1042-Q1 ⁽³⁾	Test method per IEC 62368-1, 1.2/50 µs waveform, V _{TEST} = 1.6 × V _{IOSM} = 10000 V _{PK} (qualification)	6250	6250	V _{PK}
	Maximum surge isolation voltage ISO1042B-Q1 ⁽³⁾	Test method per IEC 62368-1, 1.2/50 µs waveform, V _{TEST} = 1.3 × V _{IOSM} = 6000 V _{PK} (qualification)	4615	4615	V _{PK}
q _{pd}	Apparent charge ⁽⁴⁾	Method a: After I/O safety test subgroup 2/3, V _{ini} = V _{IOTM} , t _{ini} = 60 s; V _{pd(m)} = 1.2 × V _{IORM} , t _m = 10 s	≤ 5	≤ 5	pC
		Method a: After environmental tests subgroup 1, V _{ini} = V _{IOTM} , t _{ini} = 60 s; ISO1042-Q1: V _{pd(m)} = 1.6 × V _{IORM} , t _m = 10 s; ISO1042B-Q1: V _{pd(m)} = 1.2 × V _{IORM} , t _m = 10 s	≤ 5	≤ 5	
		Method b1: At routine test (100% production) and preconditioning (type test), V _{ini} = V _{IOTM} , t _{ini} = 1 s; ISO1042-Q1: V _{pd(m)} = 1.875 × V _{IORM} , t _m = 1 s; ISO1042B-Q1: V _{pd(m)} = 1.5 × V _{IORM} , t _m = 1 s	≤ 5	≤ 5	
C _{IO}	Barrier capacitance, input to output ⁽⁵⁾	V _{IO} = 0.4 × sin (2 πft), f = 1 MHz	1	1	pF
R _{IO}	Insulation resistance, input to output ⁽⁵⁾	V _{IO} = 500 V, T _A = 25°C	> 10 ¹²	> 10 ¹²	Ω
		V _{IO} = 500 V, 100°C ≤ T _A ≤ 150°C	> 10 ¹¹	> 10 ¹¹	
		V _{IO} = 500 V at T _S = 150°C	> 10 ⁹	> 10 ⁹	
	Pollution degree		2	2	
	Climatic category		40/125/ 21	40/125/ 21	
UL 1577					
V _{ISO}	Withstand isolation voltage	V _{TEST} = V _{ISO} , t = 60 s (qualification); V _{TEST} = 1.2 × V _{ISO} , t = 1 s (100% production)	5000	5000	V _{RMS}

- (1) Creepage and clearance requirements should be applied according to the specific equipment isolation standards of an application. Care should be taken to maintain the creepage and clearance distance of a board design to ensure that the mounting pads of the isolator on the printed-circuit board do not reduce this distance. Creepage and clearance on a printed-circuit board become equal in certain cases. Techniques such as inserting grooves, ribs, or both on a printed circuit board are used to help increase these specifications.
- (2) ISO1042-Q1 is suitable for *safe electrical insulation* and ISO1042B-Q1 is suitable for *basic electrical insulation* only within the safety ratings. Compliance with the safety ratings shall be ensured by means of suitable protective circuits.
- (3) Testing is carried out in air or oil to determine the intrinsic surge immunity of the isolation barrier.
- (4) Apparent charge is electrical discharge caused by a partial discharge (pd).
- (5) All pins on each side of the barrier tied together creating a two-pin device.

6.8 Safety-Related Certifications

VDE	CSA	UL	CQC	TUV
Certified according to DIN VDE V 0884-11:2017- 01	Certified according to IEC 60950-1, IEC 62368-1 and IEC 60601-1	Recognized under UL 1577 Component Recognition Program	Certified according to GB4943.1-2011	Certified according to EN 61010-1:2010/A1:2019, EN 60950-1:2006/A2:2013 and EN 62368-1:2014
Maximum transient isolation voltage, 7071 V _{PK} ; Maximum repetitive peak isolation voltage, 1500 V _{PK} ; Maximum surge isolation voltage, ISO1042-Q1: 6250 V _{PK} (Reinforced) ISO1042B-Q1: 4615 V _{PK} (Basic)	CSA 60950-1-07+A1+A2, IEC 60950-1 2 nd Ed.+A1+A2 and IEC 62368-1 2 nd Ed., for pollution degree 2, material group I ISO1042-Q1: 800 V _{RMS} reinforced isolation ISO1042B-Q1: 1060 V _{RMS} basic isolation ----- CSA 60601- 1:14 and IEC 60601-1 Ed. 3.1+A1, ISO1042-Q1: 2 MOPP (Means of Patient Protection) 250 V _{RMS} (354 V _{PK}) maximum working voltage	Single protection, 5000 V _{RMS}	Reinforced insulation, Altitude ≤ 5000 m, Tropical Climate, 700 V _{RMS} maximum working voltage	EN 61010-1:2010 /A1:2019 ISO1042-Q1: 600 V _{RMS} reinforced isolation ISO1042B-Q1: 1000 V _{RMS} basic isolation ----- EN 60950-1:2006/A2:2013 and EN 62368-1:2014 ISO1042-Q1: 800 V _{RMS} reinforced isolation ISO1042B-Q1: 1060 V _{RMS} basic isolation
Certificates: Reinforced: 40040142 Basic: 40047657	Master contract number: 220991	File number: E181974	Certificate: CQC15001121716 (DW-16) CQC18001199096 (DWV-8)	Client ID number: 77311

6.9 Safety Limiting Values

Safety limiting⁽¹⁾ intends to minimize potential damage to the isolation barrier upon failure of input or output circuitry.

PARAMETER		TEST CONDITIONS	MIN	TYP	MAX	UNIT
DW-16 PACKAGE						
I _S	Safety input, output, or supply current	R _{θJA} = 69.9°C/W, V _I = 5.5 V, T _J = 150°C, T _A = 25°C, see 图 1			325	mA
		R _{θJA} = 69.9°C/W, V _I = 3.6 V, T _J = 150°C, T _A = 25°C, see 图 1			496	
		R _{θJA} = 69.9°C/W, V _I = 2.75 V, T _J = 150°C, T _A = 25°C, see 图 1			650	
		R _{θJA} = 69.9°C/W, V _I = 1.89 V, T _J = 150°C, T _A = 25°C, see 图 1			946	
P _S	Safety input, output, or total power	R _{θJA} = 69.9°C/W, T _J = 150°C, T _A = 25°C, see 图 3			1788	mW
T _S	Maximum safety temperature				150	°C
DWV-8 PACKAGE						
I _S	Safety input, output, or supply current	R _{θJA} = 100°C/W, V _I = 5.5 V, T _J = 150°C, T _A = 25°C, see 图 2			227	mA
		R _{θJA} = 100°C/W, V _I = 3.6 V, T _J = 150°C, T _A = 25°C, see 图 2			347	
		R _{θJA} = 100°C/W, V _I = 2.75 V, T _J = 150°C, T _A = 25°C, see 图 2			454	
		R _{θJA} = 100°C/W, V _I = 1.89 V, T _J = 150°C, T _A = 25°C, see 图 2			661	
P _S	Safety input, output, or total power	R _{θJA} = 100°C/W, T _J = 150°C, T _A = 25°C, see 图 4			1250	mW
T _S	Maximum safety temperature				150	°C

(1) The maximum safety temperature, T_S, has the same value as the maximum junction temperature, T_J, specified for the device. The I_S and P_S parameters represent the safety current and safety power respectively. The maximum limits of I_S and P_S should not be exceeded. These limits vary with the ambient temperature, T_A.

The junction-to-air thermal resistance, R_{θJA}, in the table is that of a device installed on a high-K test board for leaded surface-mount packages. Use these equations to calculate the value for each parameter:

$$T_J = T_A + R_{\theta JA} \times P, \text{ where } P \text{ is the power dissipated in the device.}$$

$$T_{J(max)} = T_S = T_A + R_{\theta JA} \times P_S, \text{ where } T_{J(max)} \text{ is the maximum allowed junction temperature.}$$

$$P_S = I_S \times V_I, \text{ where } V_I \text{ is the maximum input voltage.}$$

6.10 Electrical Characteristics - DC Specification

Over recommended operating conditions (unless otherwise noted)

PARAMETER		TEST CONDITIONS	MIN	TYP	MAX	UNIT
SUPPLY CHARACTERISTICS						
I _{CC1}	Supply current Side 1	V _{CC1} = 1.71 V to 1.89 V, TXD = 0 V, bus dominant		2.3	3.5	mA
		V _{CC1} = 2.25 V to 5.5 V, TXD = 0 V, bus dominant		2.4	3.5	mA
		V _{CC1} = 1.71 V to 1.89 V, TXD = V _{CC1} , bus recessive		1.2	2.1	mA
		V _{CC1} = 2.25 V to 5.5 V, TXD = V _{CC1} , bus recessive		1.3	2.1	mA
I _{CC2}	Supply current Side 2	TXD = 0 V, bus dominant, R _L = 60 Ω		43	73.4	mA
		TXD = V _{CC1} , bus recessive, R _L = 60 Ω		2.8	4.1	mA
UV _{VCC1}	Rising under voltage detection, Side 1				1.7	V
UV _{VCC1}	Falling under voltage detection, Side 1		1.0			V
V _{HYS(UVC C1)}	Hysteresis voltage on V _{CC1} undervoltage lock-out		75	125		mV
UV _{VCC2}	Rising under voltage detection, side 2			4.2	4.45	V
UV _{VCC2}	Falling under voltage detection, side 2		3.8	4.0	4.25	V
V _{HYS(UVC C2)}	Hysteresis voltage on V _{CC2} undervoltage lock-out			200		mV
TXD TERMINAL						
V _{IH}	High level input voltage		0.7×V _{CC1}			V
V _{IL}	Low level input voltage		0.3×V _{CC1}			V
I _{IH}	High level input leakage current	TXD = V _{CC1}			1	μA
I _{IL}	Low level input leakage current	TXD = 0V	-20			μA
C _I	Input capacitance	V _{IN} = 0.4 x sin(2 x π x 1E+6 x t) + 2.5 V, V _{CC1} = 5 V	3			pF
RXD TERMINAL						
V _{OH} - V _{CC1}	High level output voltage	See Fig 18 , I _O = -4 mA for 4.5 V ≤ V _{CC1} ≤ 5.5 V	-0.4	-0.2		V
		See Fig 18 , I _O = -2 mA for 3.0 V ≤ V _{CC1} ≤ 3.6 V	-0.2	-0.07		V
		See Fig 18 , I _O = -1 mA for 2.25 V ≤ V _{CC1} ≤ 2.75 V	-0.1	-0.04		V
		See Fig 18 , I _O = -1 mA for 1.71 V ≤ V _{CC1} ≤ 1.89 V	-0.1	-0.045		V
V _{OL}	Low level output voltage	See Fig 18 , I _O = 4 mA for 4.5 V ≤ V _{CC1} ≤ 5.5 V		0.2	0.4	V
		See Fig 18 , I _O = 2 mA for 3.0 V ≤ V _{CC1} ≤ 3.6 V		0.07	0.2	V
		See Fig 18 , I _O = 1 mA for 2.25 V ≤ V _{CC1} ≤ 2.75 V		0.035	0.1	V
		See Fig 18 , I _O = 1 mA for 1.71 V ≤ V _{CC1} ≤ 1.89 V		0.04	0.1	V
DRIVER ELECTRICAL CHARACTERISTICS						
V _{O(DOM)}	Bus output voltage(Dominant), CANH	See Fig 15 and Fig 16 , TXD = 0 V, 50 Ω ≤ R _L ≤ 65 Ω, C _L = open	2.75		4.5	V
	Bus output voltage(Dominant), CANL	See Fig 15 and Fig 16 , TXD = 0 V, 50 Ω ≤ R _L ≤ 65 Ω, C _L = open	0.5		2.25	V
V _{O(REC)}	Bus output voltage(recessive), CANH and CANL	See Fig 15 and Fig 16 , TXD = V _{CC1} , R _L = open	2.0	0.5 x V _{CC2}	3.0	V

Electrical Characteristics - DC Specification (continued)

Over recommended operating conditions (unless otherwise noted)

PARAMETER		TEST CONDITIONS	MIN	TYP	MAX	UNIT
V _{OD(DOM)}	Differential output voltage, CANH-CANL (dominant)	See 图 15 and 图 16, TXD = 0 V, 45 Ω ≤ R _L ≤ 50 Ω, C _L = open	1.4		3.0	V
	Differential output voltage, CANH-CANL (dominant)	See 图 15 and 图 16, TXD = 0 V, 50 Ω ≤ R _L ≤ 65 Ω, C _L = open	1.5		3.0	V
	Differential output voltage, CANH-CANL (dominant)	See 图 15 and 图 16, TXD = 0 V, R _L = 2240 Ω, C _L = open	1.5		5.0	V
V _{OD(REC)}	Differential output voltage, CANH-CANL (recessive)	See 图 15 and 图 16, TXD = V _{CC1} , R _L = 60 Ω, C _L = open	-120.0		12.0	mV
	Differential output voltage, CANH-CANL (recessive)	See 图 15 and 图 16, TXD = V _{CC1} , R _L = open, C _L = open	-50.0		50.0	mV
V _{SYM_DC}	DC Output symmetry (V _{CC2} - V _{O(CANH)} - V _{O(CANL)})	See 图 15 and 图 16, R _L = 60 Ω, C _L = open, TXD = V _{CC1} or 0 V	-400.0		400.0	mV
I _{SO(SS_DO M)}	Short circuit current steady state output current, dominant	See 图 23, V _{CANH} = -5 V to 40 V, CANL = open, TXD = 0 V	-100.0			mA
		See 图 23, V _{CANL} = -5 V to 40 V, CANH = open, TXD = 0 V			100.0	mA
I _{SO(SS_RE C)}	Short circuit current steady state output current, recessive	See 图 23, -27 V ≤ V _{BUS} ≤ 32 V, V _{BUS} = CANH = CANL, TXD = V _{CC1}	-5.0		5.0	mA
RECEIVER ELECTRICAL CHARACTERISTICS						
V _{IT}	Differential input threshold voltage	See 图 18 and 表 1, V _{CM} ≤ 20 V	500.0		900.0	mV
	Differential input threshold voltage	See 图 18 and 表 1, 20 V ≤ V _{CM} ≤ 30 V	400.0		1000.0	
V _{HYS}	Hysteresis voltage for differential input threshold	See 图 18 and 表 1		120		
V _{CM}	Input common mode range	See 图 18 and 表 1	-30.0		30.0	V
I _{OFF(LKG)}	Power-off bus input leakage current	CANH = CANL = 5 V, V _{CC2} to GND via 0 Ω and 47 kΩ resistor			4.8	μA
C _I	Input capacitance to ground (CANH or CANL)	TXD = V _{CC1}		24.0	30	pF
C _{ID}	Differential input capacitance (CANH-CANL)	TXD = V _{CC1}		12.0	15	pF
R _{ID}	Differential input resistance	TXD = V _{CC1} ; -30 V ≤ V _{CM} ≤ +30 V	30.0		80.0	kΩ
R _{IN}	Input resistance (CANH or CANL)	TXD = V _{CC1} ; -30 V ≤ V _{CM} ≤ +30 V	15.0		40.0	kΩ
R _{IN(M)}	Input resistance matching: (1 - R _{IN(CANH)} /R _{IN(CANL)}) x 100%	V _{CANH} = V _{CANL} = 5 V	-2.0		2.0	%
THERMAL SHUTDOWN						
T _{TSD}	Thermal shutdown temperature			170		°C
T _{TSD_HYS T}	Thermal shutdown hysteresis			5		°C

6.11 Switching Characteristics

Over recommended operating conditions (unless otherwise noted)

PARAMETER		TEST CONDITIONS	MIN	TYP	MAX	UNIT
DEVICE SWITCHING CHARACTERISTICS						
$t_{PROP(LO\ OP1)}$	Total loop delay, driver input TXD to receiver RXD, recessive to dominant	See Figure 20 , $R_L = 60\ \Omega$, $C_L = 100\ \text{pF}$, $C_{L(RXD)} = 15\ \text{pF}$; input rise/fall time (10% to 90%) on TXD = 1 ns; $1.71\ \text{V} \leq V_{CC1} \leq 1.89\ \text{V}$	70	125	198.0	ns
		See Figure 20 , $R_L = 60\ \Omega$, $C_L = 100\ \text{pF}$, $C_{L(RXD)} = 15\ \text{pF}$; input rise/fall time (10% to 90%) on TXD = 1 ns; $2.25\ \text{V} \leq V_{CC1} \leq 5.5\ \text{V}$	70	122	192.0	ns
$t_{PROP(LO\ OP2)}$	Total loop delay, driver input TXD to receiver RXD, dominant to recessive	See Figure 20 , $R_L = 60\ \Omega$, $C_L = 100\ \text{pF}$, $C_{L(RXD)} = 15\ \text{pF}$; input rise/fall time (10% to 90%) on TXD = 1 ns; $1.71\ \text{V} \leq V_{CC1} \leq 1.89\ \text{V}$	70	155	215.0	ns
		See Figure 20 , $R_L = 60\ \Omega$, $C_L = 100\ \text{pF}$, $C_{L(RXD)} = 15\ \text{pF}$; input rise/fall time (10% to 90%) on TXD = 1 ns; $2.25\ \text{V} \leq V_{CC1} \leq 5.5\ \text{V}$	70	152	215.0	ns
$t_{UV_RE_ENABLE}$	Re-enable time after Undervoltage event	Time for device to return to normal operation from V_{CC1} or V_{CC2} under voltage event			300.0	μs
CMTI	Common mode transient immunity	$V_{CM} = 1200\ \text{V}_{PK}$, See Figure 24	85	100		$\text{kV}/\mu\text{s}$
DRIVER SWITCHING CHARACTERISTICS						
t_{pHR}	Propagation delay time, HIGH TXD to driver recessive	See Figure 17 , $R_L = 60\ \Omega$ and $C_L = 100\ \text{pF}$; input rise/fall time (10% to 90%) on TXD = 1 ns		76	120	ns
t_{pLD}	Propagation delay time, LOW TXD to driver dominant			61	120	
$t_{sk(p)}$	Pulse skew ($ t_{pHR} - t_{pLD} $)			14		
t_R	Differential output signal rise time			45		
t_F	Differential output signal fall time			45		
V_{SYM}	Output symmetry (dominant or recessive) $(V_{O(CANH)} + V_{O(CANL)}) / V_{CC2}$	See Figure 17 and Figure 31 , $R_{TERM} = 60\ \Omega$, $C_{SPLIT} = 4.7\ \text{nF}$, $C_L = \text{open}$, $R_L = \text{open}$, TXD = 250 kHz, 1 MHz	0.9		1.1	V/V
t_{TXD_DTO}	Dominant time out	See Figure 22 , $R_L = 60\ \Omega$ and $C_L = \text{open}$	1.2		3.8	ms
RECEIVER SWITCHING CHARACTERISTICS						
t_{pRH}	Propagation delay time, bus recessive input to RXD high output	See Figure 19 , $C_{L(RXD)} = 15\ \text{pF}$		75	130	ns
t_{pDL}	Propagation delay time, bus dominant input to RXD low output			63	130	ns
t_R	Output signal rise time(RXD)			1.4		ns
t_F	Output signal fall time(RXD)			1.8		ns
FD TIMING PARAMETERS						
$t_{BIT(BUS)}$	Bit time on CAN bus output pins with $t_{BIT(TXD)} = 500\ \text{ns}$	See Figure 21 , $R_L = 60\ \Omega$, $C_L = 100\ \text{pF}$, $C_{L(RXD)} = 15\ \text{pF}$; input rise/fall time (10% to 90%) on TXD = 1 ns	435.0		530.0	ns
	Bit time on CAN bus output pins with $t_{BIT(TXD)} = 200\ \text{ns}$	See Figure 21 , $R_L = 60\ \Omega$, $C_L = 100\ \text{pF}$, $C_{L(RXD)} = 15\ \text{pF}$; input rise/fall time (10% to 90%) on TXD = 1 ns	155.0		210.0	ns
$t_{BIT(RXD)}$	Bit time on RXD output pins with $t_{BIT(TXD)} = 500\ \text{ns}$	See Figure 21 , $R_L = 60\ \Omega$, $C_L = 100\ \text{pF}$, $C_{L(RXD)} = 15\ \text{pF}$; input rise/fall time (10% to 90%) on TXD = 1 ns	400		550.0	ns
	Bit time on RXD output pins with $t_{BIT(TXD)} = 200\ \text{ns}$	See Figure 21 , $R_L = 60\ \Omega$, $C_L = 100\ \text{pF}$, $C_{L(RXD)} = 15\ \text{pF}$; input rise/fall time (10% to 90%) on TXD = 1 ns	120.0		220.0	ns

Switching Characteristics (continued)

Over recommended operating conditions (unless otherwise noted)

PARAMETER		TEST CONDITIONS	MIN	TYP	MAX	UNIT
Δt_{REC}	Receiver timing symmetry with $t_{BIT(TXD)} = 500$ ns	See 图 21, $R_L = 60 \Omega$, $C_L = 100$ pF, $C_{L(RXD)} = 15$ pF; input rise/fall time (10% to 90%) on TXD = 1 ns; $\Delta t_{REC} = t_{BIT(RXD)} - t_{BIT(BUS)}$	-65.0		40.0	ns
	Receiver timing symmetry with $t_{BIT(TXD)} = 200$ ns	See 图 21, $R_L = 60 \Omega$, $C_L = 100$ pF, $C_{L(RXD)} = 15$ pF; input rise/fall time (10% to 90%) on TXD = 1 ns; $\Delta t_{REC} = t_{BIT(RXD)} - t_{BIT(BUS)}$	-45.0		15.0	ns

6.12 Insulation Characteristics Curves



图 1. Thermal Derating Curve for Limiting Current per VDE for DW-16 Package



图 2. Thermal Derating Curve for Limiting Current per VDE for DWV-8 Package

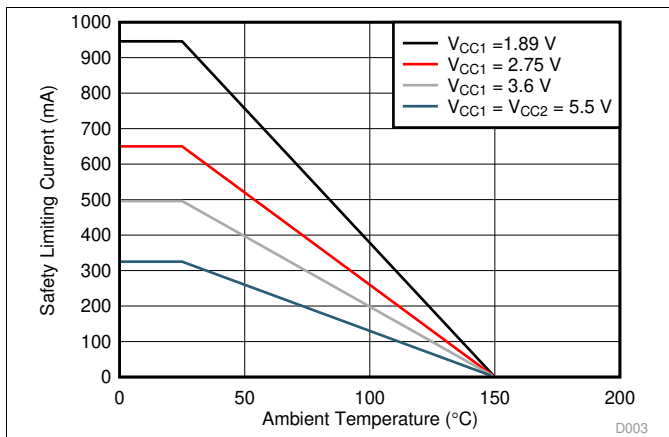

图 3. Thermal Derating Curve for Limiting Power per VDE for DW-16 Package

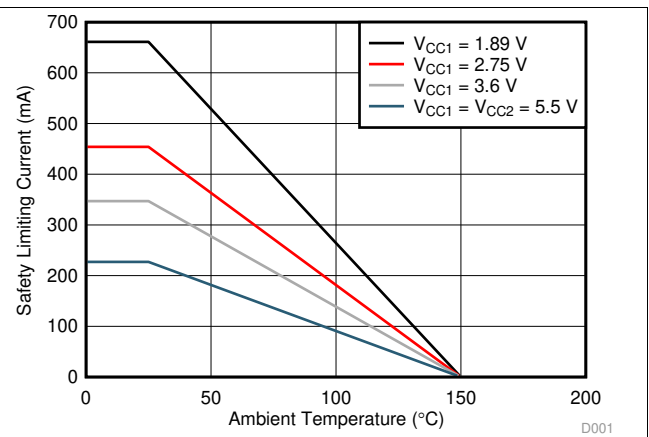

图 4. Thermal Derating Curve for Limiting Power per VDE for DWV-8 Package

6.13 Typical Characteristics

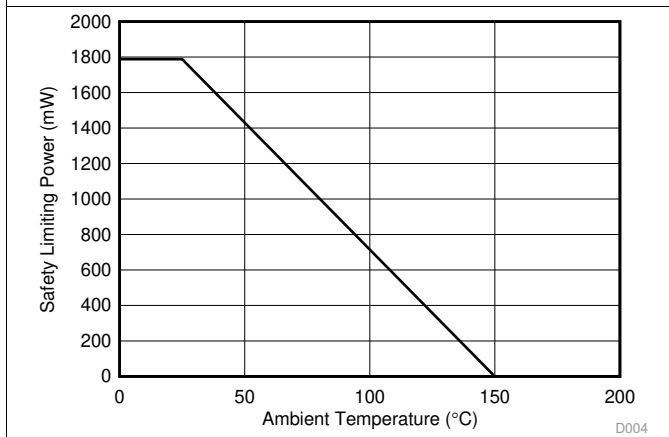

图 5. I_{CC2} vs V_{CC2} for Recessive, Dominant and Different CAN Datarates

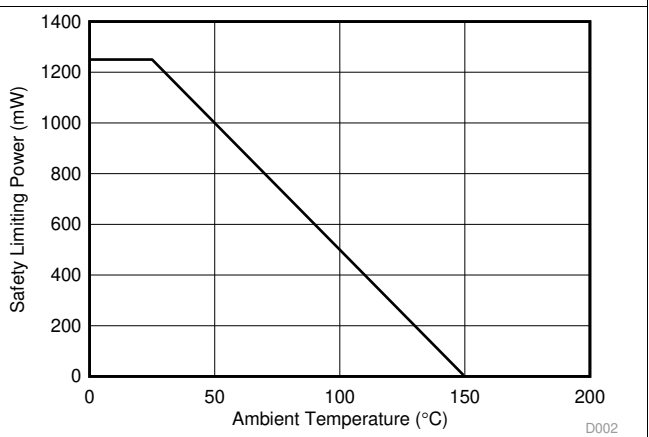

图 6. I_{CC1} vs Datarate

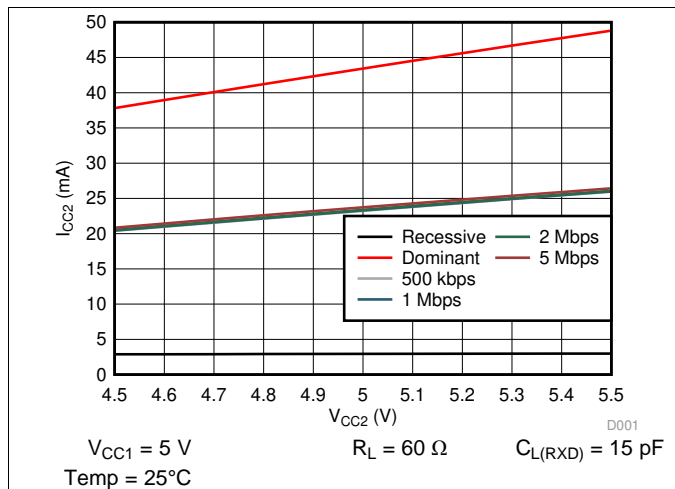

图 7. I_{CC2} vs Ambient Temperature for Recessive, Dominant and Different CAN Datarates

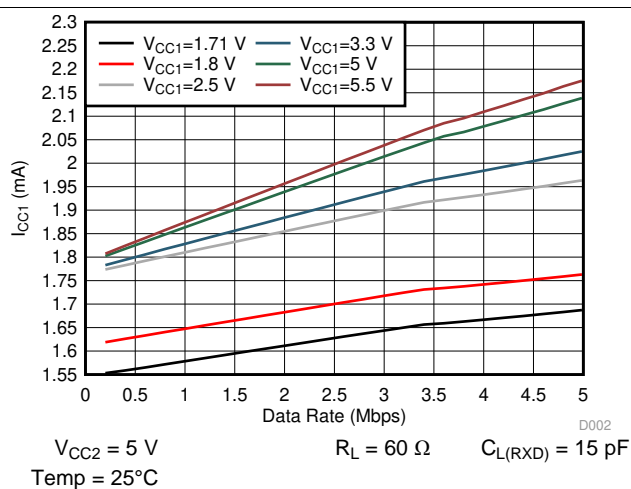

图 8. : I_{CC1} vs Ambient Temperature for Recessive, Dominant and Different CAN Datarates.

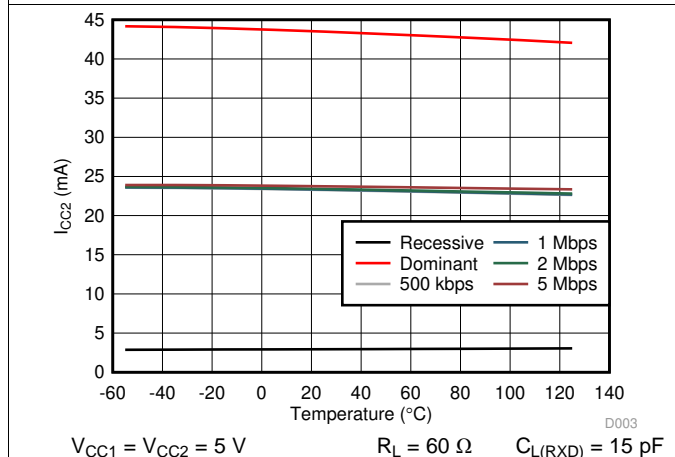

图 9. Loop Delay vs Ambient Temperature

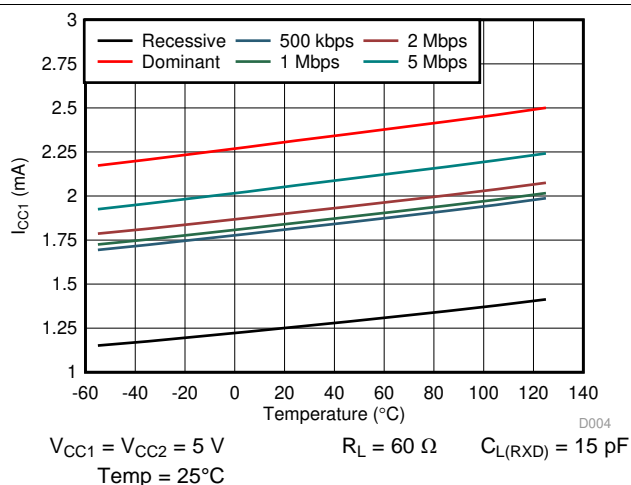

图 10. $V_{OD(DOM)}$ Over Temperature

Typical Characteristics (接下页)

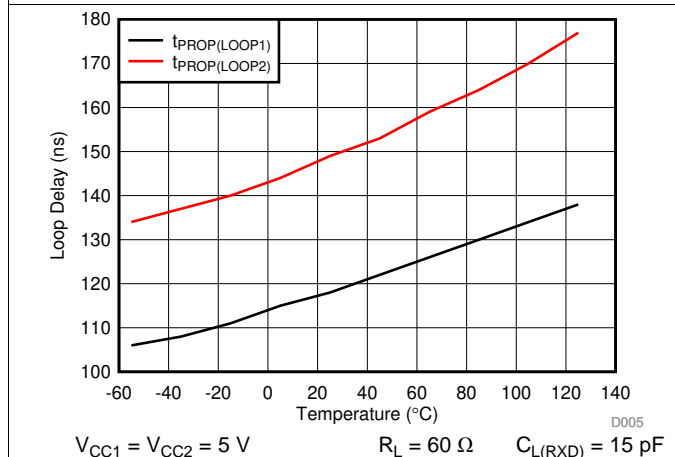

图 11. $V_{OD(DOM)}$ Over V_{CC}

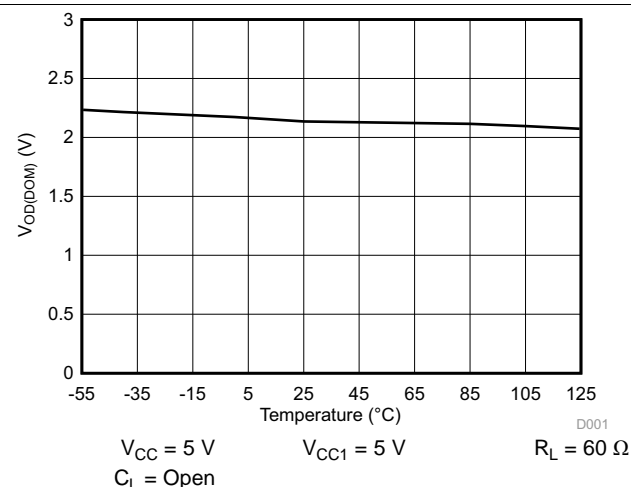

图 12. Typical TXD, RXD, CANH and CANL Waveforms at 1 Mbps

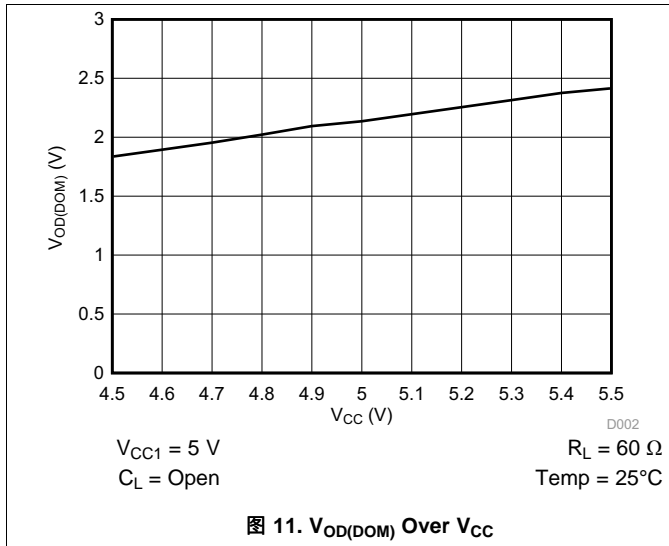

图 13. Glitch Free Power Up on V_{CC1} – CAN Bus Remains Recessive

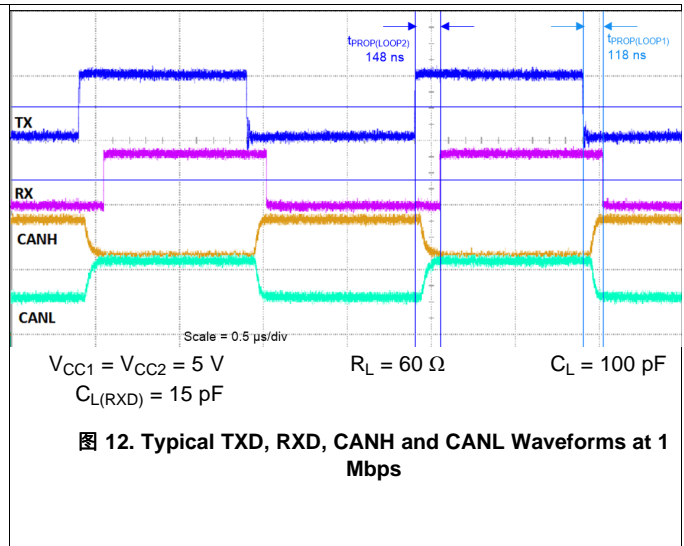

图 14. Glitch Free Power Up on V_{CC2} – CAN Bus Remains Recessive

7 Parameter Measurement Information

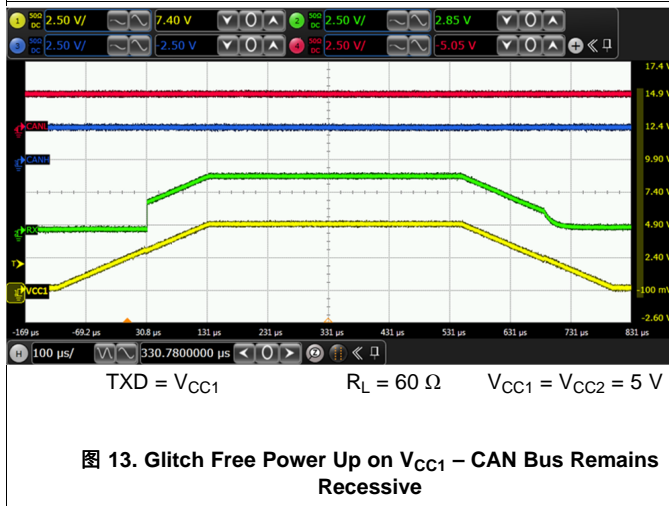
7.1 Test Circuits

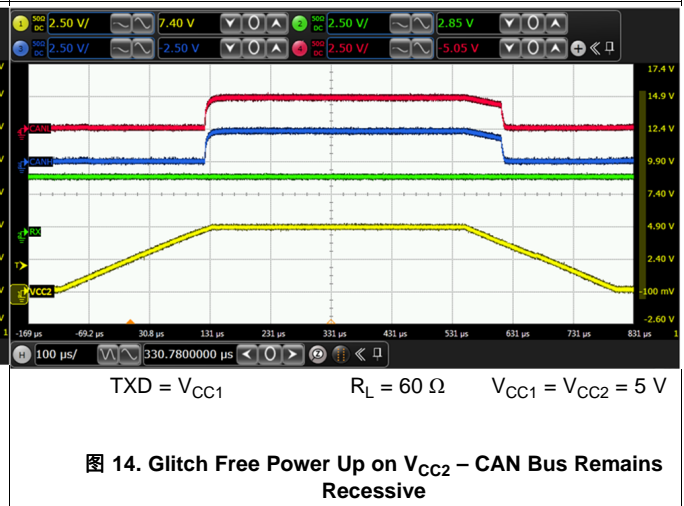

图 15. Driver Voltage, Current and Test Definitions



图 16. Bus Logic State Voltage Definitions

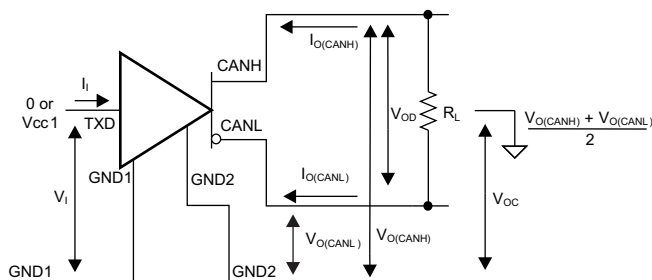

- A. The input pulse is supplied by a generator having the following characteristics: PRR \leq 125 kHz, 50% duty cycle, $t_r \leq$ 6 ns, $t_f \leq$ 6 ns, $Z_0 = 50 \Omega$.

图 17. Driver Test Circuit and Voltage Waveforms

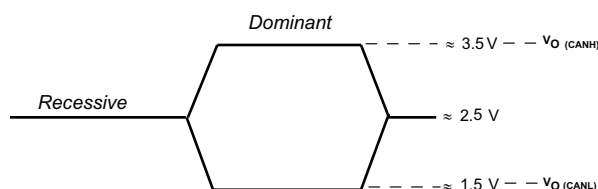
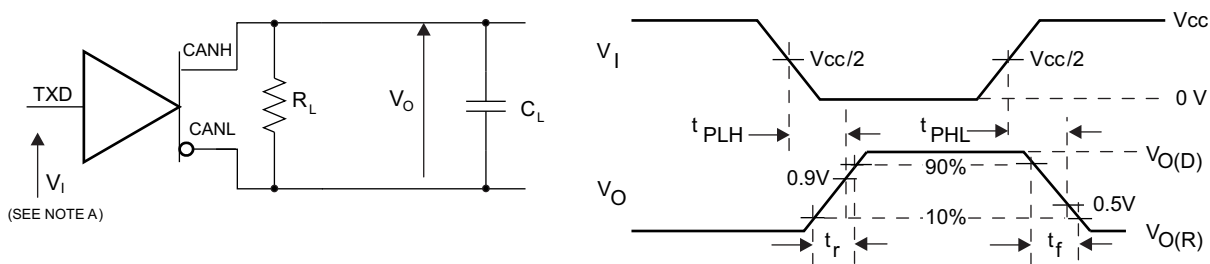

图 18. Receiver Voltage and Current Definitions

Test Circuits (接下页)

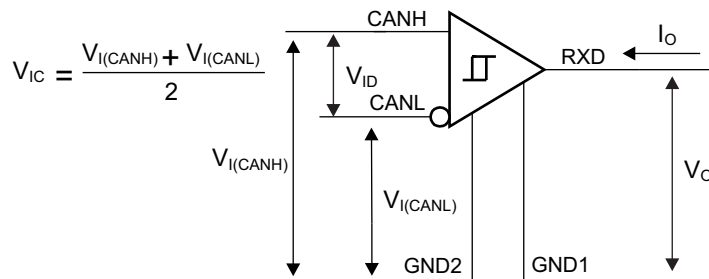
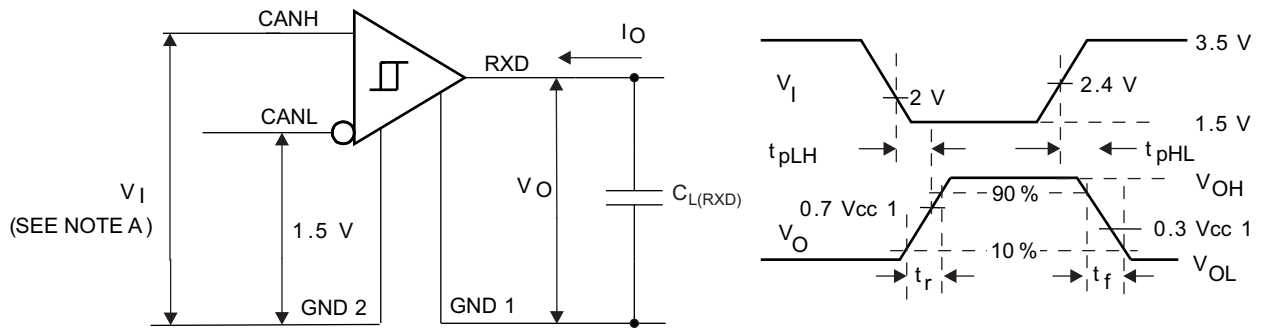

A. The input pulse is supplied by a generator having the following characteristics: PRR ≤ 125 kHz, 50% duty cycle, $t_r \leq 6$ ns, $t_f \leq 6$ ns, $Z_O = 50 \Omega$.

图 19. Receiver Test Circuit and Voltage Waveforms

表 1. Receiver Differential Input Voltage Threshold Test

INPUT			OUTPUT	
V_{CANH}	V_{CANL}	$ V_{ID} $	RXD	
-29.5 V	-30.5 V	1000 mV	L	V_{OL}
30.5 V	29.5 V	1000 mV	L	
-19.55 V	-20.45 V	900 mV	L	
20.45 V	19.55 V	900 mV	L	
-19.75 V	-20.25 V	500 mV	H	V_{OH}
20.25 V	19.75 V	500 mV	H	
-29.8 V	-30.2 V	400 mV	H	
30.2 V	29.8 V	400 mV	H	
Open	Open	X	H	



图 20. t_{LOOP} Test Circuit and Voltage Waveforms



图 21. CAN FD Timing Parameter Measurement

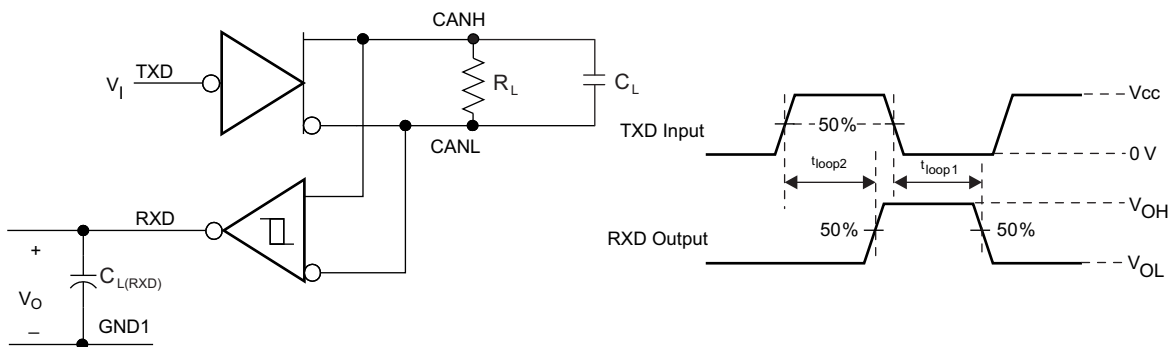

A. The input pulse is supplied by a generator having the following characteristics: $t_r \leq 6$ ns, $t_f \leq 6$ ns, $Z_O = 50 \Omega$.

图 22. Dominant Time-out Test Circuit and Voltage Waveforms

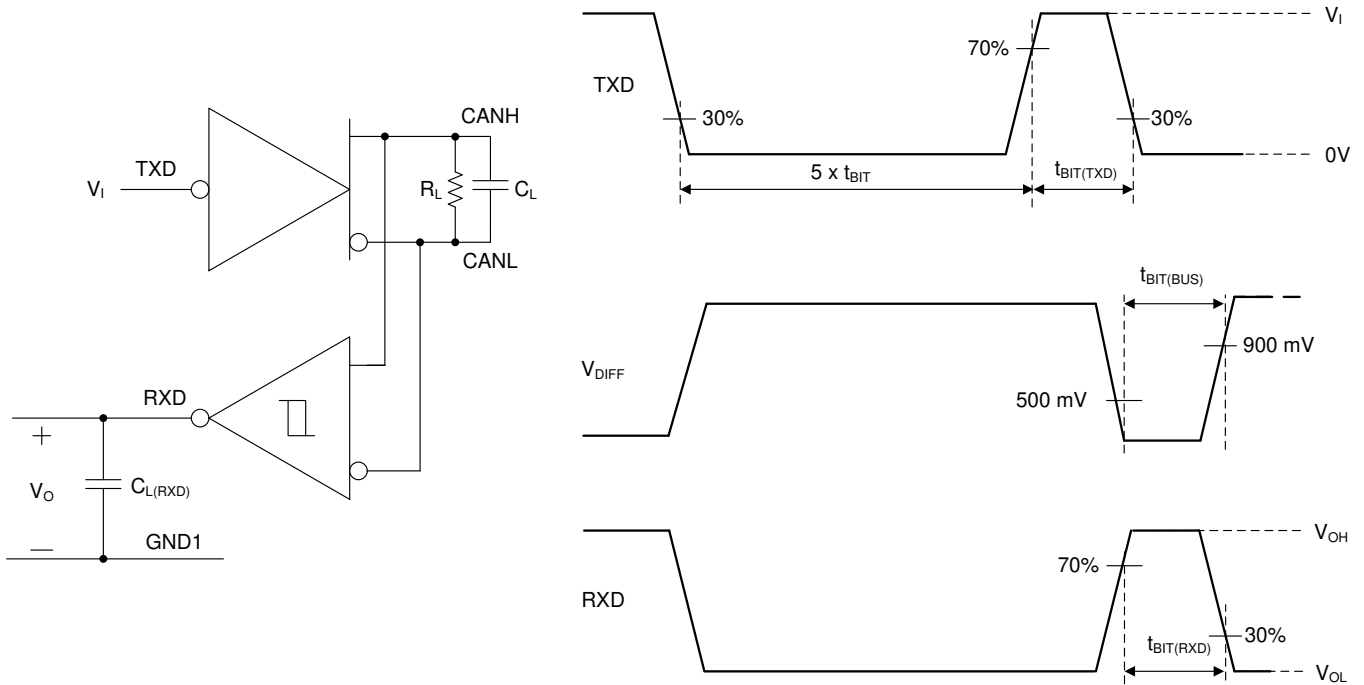
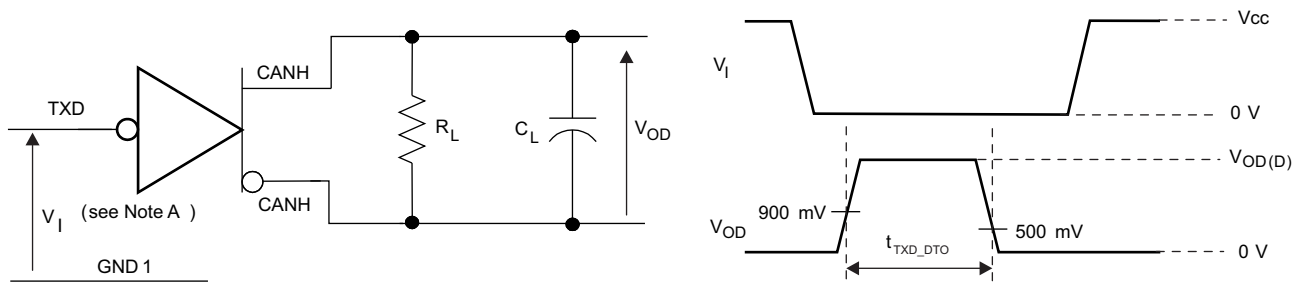

图 23. Driver Short-Circuit Current Test Circuit and Waveforms



图 24. Common-Mode Transient Immunity Test Circuit

8 Detailed Description

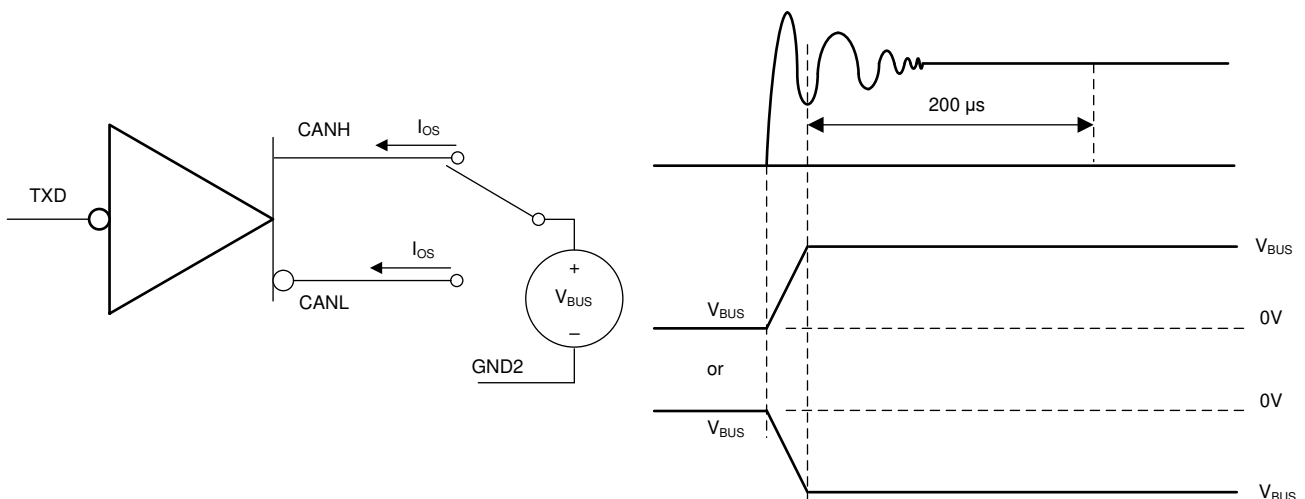
8.1 Overview

The ISO1042-Q1 device is a digitally isolated CAN transceiver that offers ± 70 -V DC bus fault protection and ± 30 -V common-mode voltage range. The device supports up to 5-Mbps data rate in CAN FD mode allowing much faster transfer of payload compared to classic CAN. The ISO1042-Q1 device has an isolation withstand voltage of $5000 V_{RMS}$ and is available in basic and reinforced isolation with a surge test voltage of $6 kV_{PK}$ and $10 kV_{PK}$ respectively. The device can operate from 1.8-V, 2.5-V, 3.3-V, and 5-V supplies on side 1 and a 5-V supply on side 2. This supply range is of particular advantage for applications operating in harsh industrial environments because the low voltage on side 1 enables the connection to low-voltage microcontrollers for power conservation, whereas the 5 V on side 2 maintains a high signal-to-noise ratio of the bus signals.

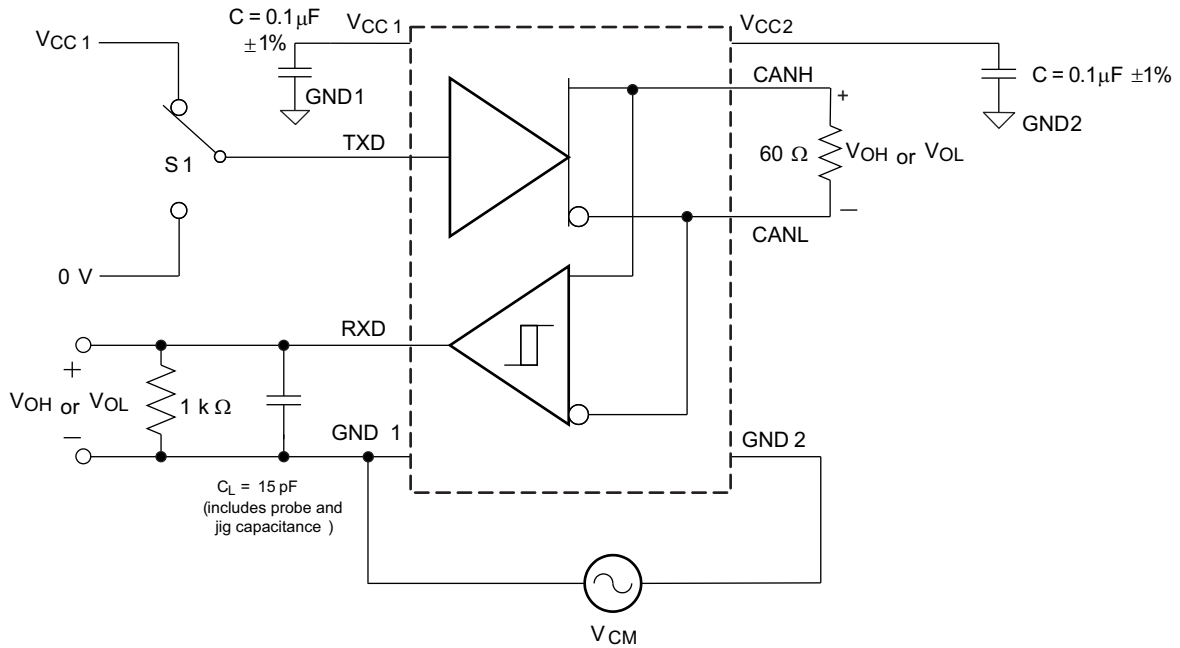
8.2 Functional Block Diagram

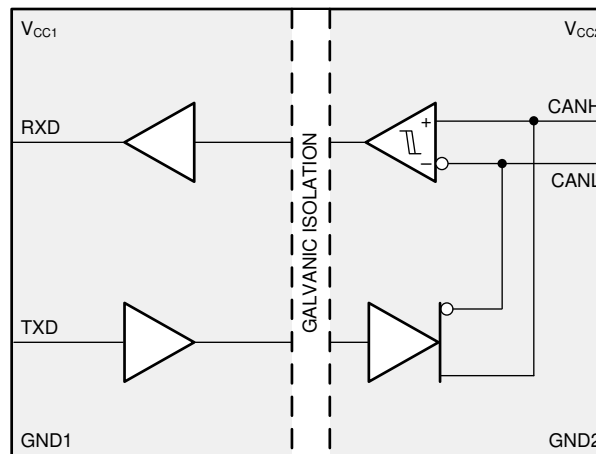

8.3 Feature Description

8.3.1 CAN Bus States

The CAN bus has two states during operation: *dominant* and *recessive*. A dominant bus state, equivalent to logic low, is when the bus is driven differentially by a driver. A recessive bus state is when the bus is biased to a common mode of $V_{CC} / 2$ through the high-resistance internal input resistors of the receiver, equivalent to a logic high. The host microprocessor of the CAN node uses the TXD pin to drive the bus and receives data from the bus on the RXD pin. See [Figure 25](#) and [Figure 26](#).

Feature Description (接下页)



图 25. Bus States (Physical Bit Representation)



图 26. Simplified Recessive Common Mode Bias and Receiver

8.3.2 Digital Inputs and Outputs: TXD (Input) and RXD (Output)

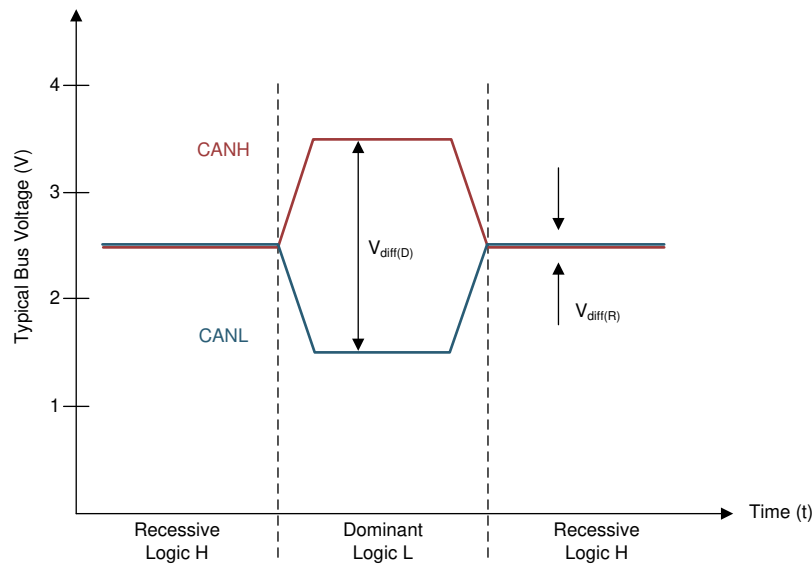
The V_{CC1} supply for the isolated digital input and output side of the device can be supplied by 1.8-V, 2.5-V, 3.3-V, and 5-V supplies and therefore the digital inputs and outputs are 1.8-V, 2.5-V, 3.3-V, and 5-V compatible.

注

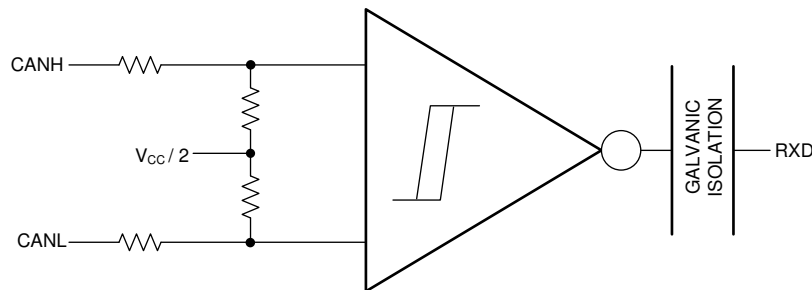
The TXD pin is very weakly internally pulled up to V_{CC1} . An external pullup resistor should be used to make sure that the TXD pin is biased to recessive (high) level to avoid issues on the bus if the microprocessor does not control the pin and the TXD pin floats. The TXD pullup strength and CAN bit timing require special consideration when the device is used with an open-drain TXD output on the CAN controller of the microprocessor. An adequate external pullup resistor must be used to make sure that the TXD output of the microprocessor maintains adequate bit timing input to the input on the transceiver.

Feature Description (接下页)

8.3.3 Protection Features

8.3.3.1 TXD Dominant Timeout (DTO)

The TXD DTO circuit prevents the transceiver from blocking network communication in the event of a hardware or software failure where the TXD pin is held dominant longer than the timeout period, t_{TXD_DTO} . The DTO circuit timer starts on a falling edge on the TXD pin. The DTO circuit disables the CAN bus driver if no rising edge occurs before the timeout period expires, which frees the bus for communication between other nodes on the network. The CAN driver is activated again when a recessive signal occurs on the TXD pin, clearing the TXD DTO condition. The receiver and RXD pin still reflect activity on the CAN bus, and the bus terminals are biased to the recessive level during a TXD dominant timeout.



图 27. Example Timing Diagram for TXD DTO

注

The minimum dominant TXD time (t_{TXD_DTO}) allowed by the TXD DTO circuit limits the minimum possible transmitted data rate of the device. The CAN protocol allows a maximum of eleven successive dominant bits (on TXD) for the worst case, where five successive dominant bits are followed immediately by an error frame. This, along with the t_{TXD_DTO} minimum, limits the minimum data rate. Calculate the minimum transmitted data rate with 公式 1.

$$\text{Minimum Data Rate} = 11 / t_{TXD_DTO}$$

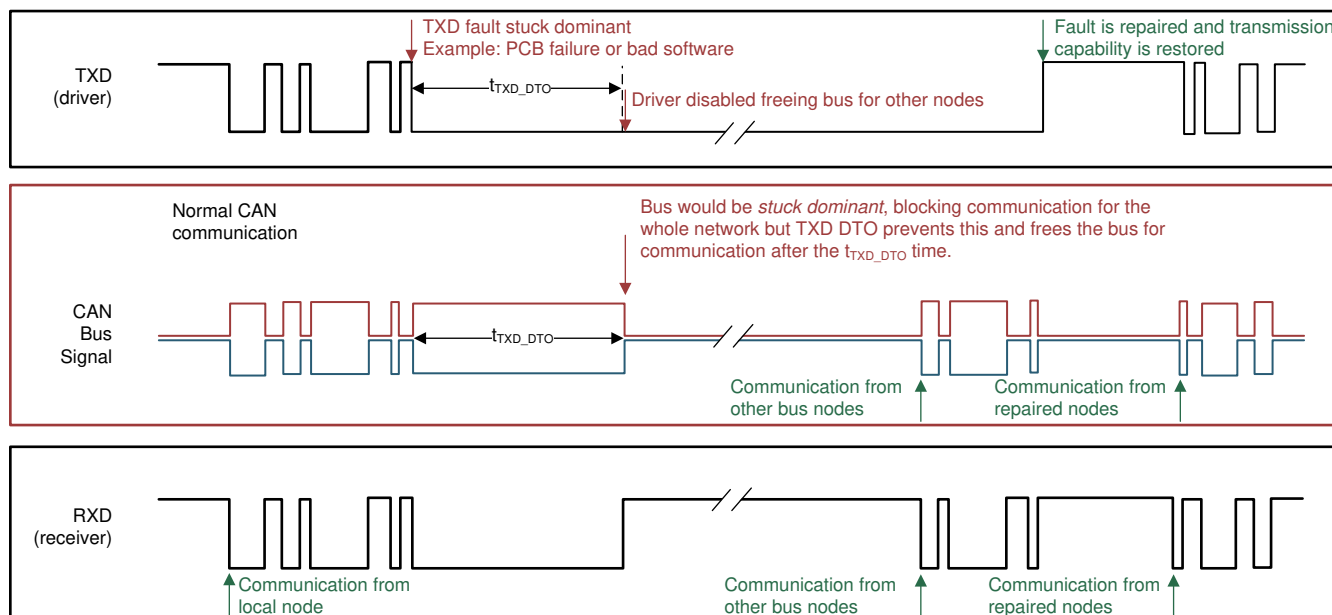
(1)

8.3.3.2 Thermal Shutdown (TSD)

If the junction temperature of the device exceeds the thermal shutdown threshold (T_{TSD}), the device turns off the CAN driver circuits, blocking the TXD-to-bus transmission path. The CAN bus terminals are biased to the recessive level during a thermal shutdown, and the receiver-to-RXD path remains operational. The shutdown condition is cleared when the junction temperature drops at least the thermal shutdown hysteresis temperature (T_{TSD_HYST}) below the thermal shutdown temperature (T_{TSD}) of the device.

Feature Description (接下页)

8.3.3.3 Undervoltage Lockout and Default State

The supply pins have undervoltage detection that places the device in protected or default mode which protects the bus during an undervoltage event on the V_{CC1} or V_{CC2} supply pins. If the bus-side power supply, V_{CC2} , is less than about 4 V, the power shutdown circuits in the ISO1042-Q1 device disable the transceiver to prevent false transmissions because of an unstable supply. If the V_{CC1} supply is still active when this occurs, the receiver output (RXD) goes to a default HIGH (recessive) value. 表 2 summarizes the undervoltage lockout and fail-safe behavior.

表 2. Undervoltage Lockout and Default State

V_{CC1}	V_{CC2}	DEVICE STATE	BUS OUTPUT	RXD
$> UV_{VCC1}$	$> UV_{VCC2}$	Functional	Per Device State and TXD	Mirrors Bus
$< UV_{VCC1}$	$> UV_{VCC2}$	Protected	Recessive	Undetermined
$> UV_{VCC1}$	$< UV_{VCC2}$	Protected	High Impedance	Recessive (Default High)

注

After an undervoltage condition is cleared and the supplies have returned to valid levels, the device typically resumes normal operation in 300 μ s.

8.3.3.4 Floating Pins

Pullup and pulldown resistors should be used on critical pins to place the device into known states if the pins float. The TXD pin should be pulled up through a resistor to the V_{CC1} pin to force a recessive input level if the microprocessor output to the pin floats.

8.3.3.5 Unpowered Device

The device is designed to be *ideal passive* or *no load* to the CAN bus if it is unpowered. The bus pins (CANH, CANL) have extremely low leakage currents when the device is unpowered to avoid loading down the bus which is critical if some nodes of the network are unpowered while the rest of the of network remains in operation.

8.3.3.6 CAN Bus Short Circuit Current Limiting

The device has two protection features that limit the short circuit current when a CAN bus line has a short-circuit fault condition. The first protection feature is driver current limiting (both dominant and recessive states) and the second feature is TXD dominant state time out to prevent permanent higher short circuit current of the dominant state during a system fault. During CAN communication the bus switches between dominant and recessive states, therefore the short circuit current may be viewed either as the instantaneous current during each bus state or as an average current of the two states. For system current (power supply) and power considerations in the termination resistors and common-mode choke ratings, use the average short circuit current. Determine the ratio of dominant and recessive bits by the data in the CAN frame plus the following factors of the protocol and PHY that force either recessive or dominant at certain times:

- Control fields with set bits
- Bit stuffing
- Interframe space
- TXD dominant time out (fault case limiting)

These factors ensure a minimum recessive amount of time on the bus even if the data field contains a high percentage of dominant bits. The short circuit current of the bus depends on the ratio of recessive to dominant bits and their respective short circuit currents. Use 公式 2 to calculate the average short circuit current.

$$I_{OS(AVG)} = \%Transmit \times [(\%REC_Bits \times I_{OS(SS_REC)}) + (\%DOM_Bits \times I_{OS(SS_DOM)})] + [\%Receive \times I_{OS(SS_REC)}]$$

where

- $I_{OS(AVG)}$ is the average short circuit current
- %Transmit is the percentage the node is transmitting CAN messages
- %Receive is the percentage the node is receiving CAN messages

- %REC_Bits is the percentage of recessive bits in the transmitted CAN messages
- %DOM_Bits is the percentage of dominant bits in the transmitted CAN messages
- $I_{OS(SS)_REC}$ is the recessive steady state short circuit current
- $I_{OS(SS)_DOM}$ is the dominant steady state short circuit current

(2)

注

Consider the short circuit current and possible fault cases of the network when sizing the power ratings of the termination resistance and other network components.

8.4 Device Functional Modes

表 3 和 表 4 list the driver and receiver functions. 表 5 lists the functional modes for the ISO1042-Q1 device.

表 3. Driver Function Table

INPUT	OUTPUTS		DRIVEN BUS STATE
	TXD ⁽¹⁾	CANH ⁽¹⁾	
L	H	L	Dominant
H	Z	Z	Recessive

- (1) H = high level, L = low level, Z = common mode (recessive) bias to $V_{CC} / 2$. See 图 25 and 图 26 for bus state and common mode bias information.

表 4. Receiver Function Table

DEVICE MODE	CAN DIFFERENTIAL INPUTS $V_{ID} = V_{CANH} - V_{CANL}$ ⁽¹⁾	BUS STATE	RXD PIN ⁽²⁾
Normal	$V_{ID} \geq V_{IT(MAX)}$	Dominant	L
	$V_{IT(MIN)} < V_{ID} < V_{IT(MAX)}$?	?
	$V_{ID} \leq V_{IT(MIN)}$	Recessive	H
	Open ($V_{ID} \approx 0$ V)	Open	H

- (1) See Receiver Electrical Characteristics section for input thresholds.
(2) H = high level, L = low level, ? = indeterminate.

表 5. Function Table⁽¹⁾

DRIVER			RECEIVER			
INPUTS	OUTPUTS		BUS STATE	DIFFERENTIAL INPUTS $V_{ID} = CANH - CANL$ ⁽²⁾	OUTPUT RXD	BUS STATE
TXD	CANH	CANL				
L ⁽³⁾	H	L	DOMINANT	$V_{ID} \geq V_{IT(MAX)}$	L	DOMINANT
H	Z	Z	RECESSIVE	$V_{IT(MIN)} < V_{ID} < V_{IT(MAX)}$?	?
Open	Z	Z	RECESSIVE	$V_{ID} \leq V_{IT(MIN)}$	H	RECESSIVE
X	Z	Z	RECESSIVE	Open ($V_{ID} \approx 0$ V)	H	RECESSIVE

- (1) H = high level; L = low level; X = irrelevant; ? = indeterminate; Z = high impedance
(2) See Receiver Electrical Characteristics section for input thresholds.
(3) Logic low pulses to prevent dominant time-out.

9 Application and Implementation

注

Information in the following applications sections is not part of the TI component specification, and TI does not warrant its accuracy or completeness. TI's customers are responsible for determining suitability of components for their purposes. Customers should validate and test their design implementation to confirm system functionality.

9.1 Application Information

The ISO1042-Q1 device can be used with other components from Texas Instruments such as a microcontroller, a transformer driver, and a linear voltage regulator to form a fully isolated CAN interface.

9.2 Typical Application



图 28. Application Circuit With ISO1042-Q1 in 16-SOIC Package

Typical Application (接下页)

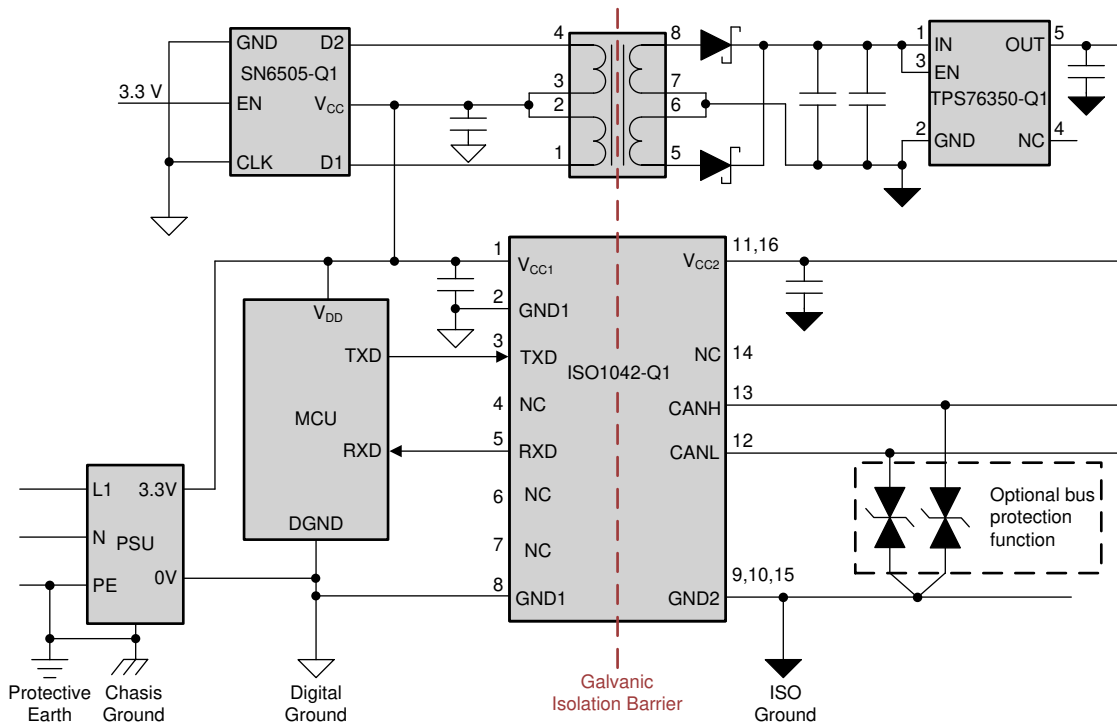

图 29. Application Circuit With ISO1042-Q1 in 8-SOIC Package

9.2.1 Design Requirements

Unlike an optocoupler-based solution, which requires several external components to improve performance, provide bias, or limit current, the ISO1042-Q1 device only requires external bypass capacitors to operate.

9.2.2 Detailed Design Procedure

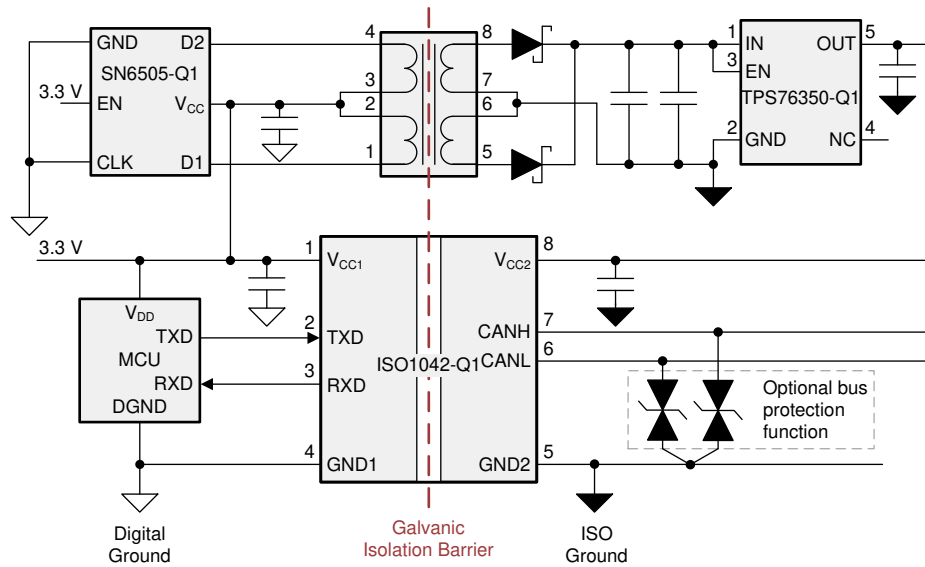
9.2.2.1 Bus Loading, Length and Number of Nodes

The ISO 11898-2 Standard specifies a maximum bus length of 40 m and maximum stub length of 0.3 m. However, with careful design, users can have longer cables, longer stub lengths, and many more nodes to a bus. A large number of nodes requires transceivers with high input impedance such as the ISO1042-Q1 transceivers.

Many CAN organizations and standards have scaled the use of CAN for applications outside the original ISO 11898-2 Standard. These organizations and standards have made system-level trade-offs for data rate, cable length, and parasitic loading of the bus. Examples of some of these specifications are ARINC825, CANopen, DeviceNet, and NMEA2000.

The ISO1042-Q1 device is specified to meet the 1.5-V requirement with a 50-Ω load, incorporating the worst case including parallel transceivers. The differential input resistance of the ISO1042-Q1 device is a minimum of 30 kΩ. If 100 ISO1042-Q1 transceivers are in parallel on a bus, this requirement is equivalent to a 300-Ω differential load worst case. That transceiver load of 300 Ω in parallel with the 60 Ω gives an equivalent loading of 50 Ω. Therefore, the ISO1042-Q1 device theoretically supports up to 100 transceivers on a single bus segment. However, for CAN network design margin must be given for signal loss across the system and cabling, parasitic loadings, network imbalances, ground offsets and signal integrity, therefore a practical maximum number of nodes is typically much lower. Bus length may also be extended beyond the original ISO 11898 standard of 40 m by careful system design and data-rate tradeoffs. For example, CANopen network design guidelines allow the network to be up to 1 km with changes in the termination resistance, cabling, less than 64 nodes, and a significantly lowered data rate.

This flexibility in CAN network design is one of the key strengths of the various extensions and additional standards that have been built on the original ISO 11898-2 CAN standard. Using this flexibility requires the responsibility of good network design and balancing these tradeoffs.

Typical Application (接下页)

9.2.2.2 CAN Termination

The ISO11898 standard specifies the interconnect to be a single twisted pair cable (shielded or unshielded) with 120-Ω characteristic impedance (Z_0). Resistors equal to the characteristic impedance of the line should be used to terminate both ends of the cable to prevent signal reflections. Unterminated drop-lines (stubs) connecting nodes to the bus should be kept as short as possible to minimize signal reflections. The termination may be in a node, but if nodes are removed from the bus, the termination must be carefully placed so that it is not removed from the bus.



图 30. Typical CAN Bus

Termination may be a single 120-Ω resistor at the end of the bus, either on the cable or in a terminating node. If filtering and stabilization of the common-mode voltage of the bus is desired, then split termination can be used. (See 图 31). Split termination improves the electromagnetic emissions behavior of the network by eliminating fluctuations in the bus common-mode voltages at the start and end of message transmissions.

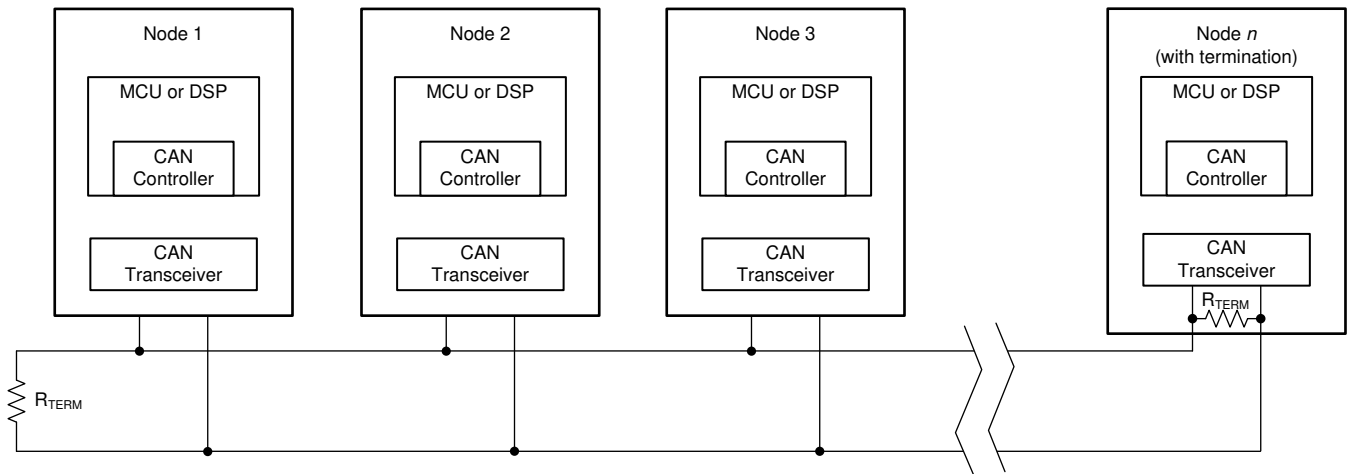

图 31. CAN Bus Termination Concepts

Typical Application (接下页)

9.2.3 Application Curve

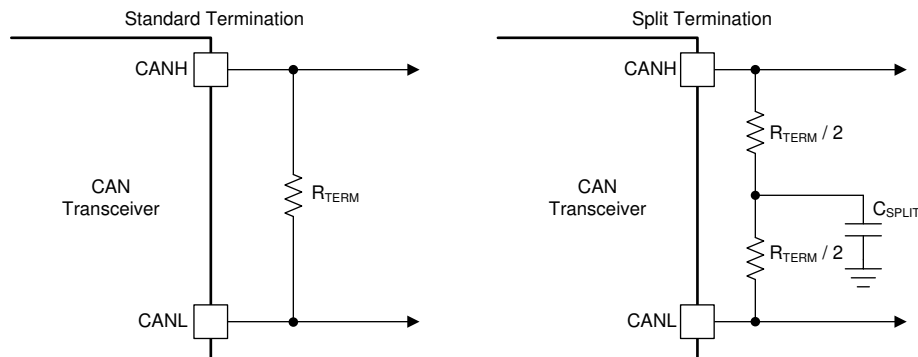

图 32. Typical TXD, RXD, CANH and CANL Waveforms at 1 Mbps

10 Power Supply Recommendations

To make sure operation is reliable at all data rates and supply voltages, a 0.1- μF bypass capacitor is recommended at the input and output supply pins (V_{CC1} and V_{CC2}). The capacitors should be placed as close to the supply pins as possible. In addition, a bulk capacitance, typically 4.7 μF , should be placed near the V_{CC2} supply pin. If only a single primary-side power supply is available in an application, isolated power can be generated for the secondary-side with the help of a transformer driver such as TI's [SN6505B](#). For such applications, detailed power supply design, and transformer selection recommendations are available in the [SN6505 Low-Noise 1-A Transformer Drivers for Isolated Power Supplies](#) data sheet.

11 Layout

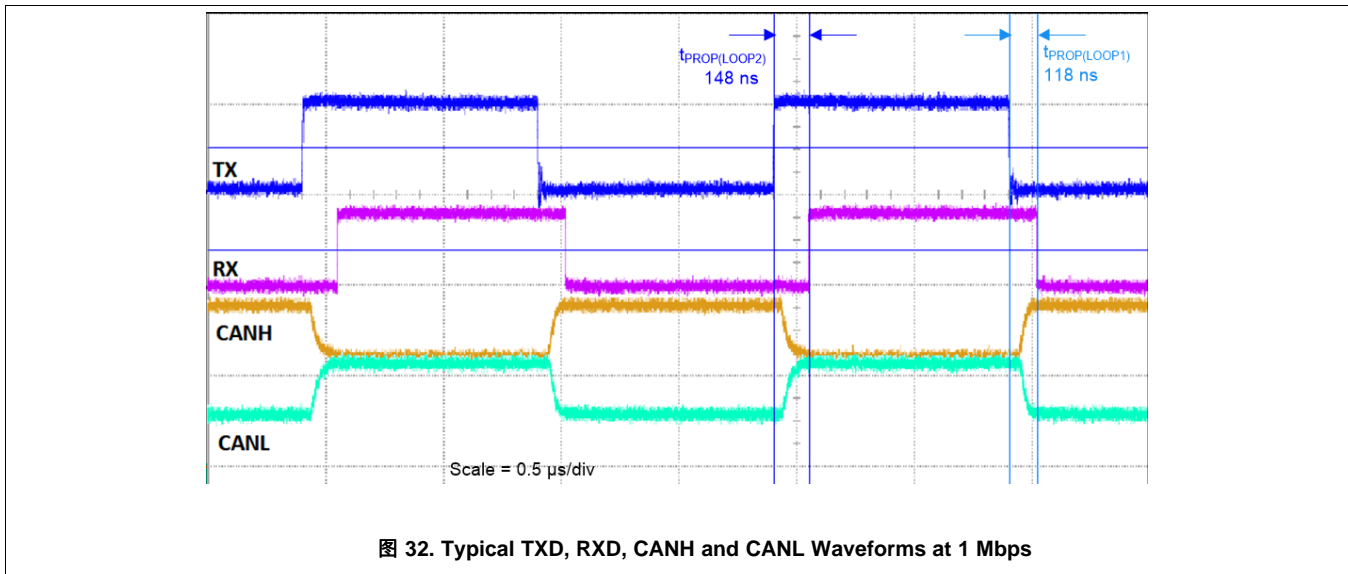
11.1 Layout Guidelines

A minimum of four layers is required to accomplish a low EMI PCB design (see [Figure 33](#)). Layer stacking should be in the following order (top-to-bottom): high-speed signal layer, ground plane, power plane and low-frequency signal layer.

- Routing the high-speed traces on the top layer avoids the use of vias (and the introduction of their inductances) and allows for clean interconnects between the isolator and the transmitter and receiver circuits of the data link.
- Placing a solid ground plane next to the high-speed signal layer establishes controlled impedance for transmission line interconnects and provides an excellent low-inductance path for the return current flow.
- Placing the power plane next to the ground plane creates additional high-frequency bypass capacitance of approximately 100 pF/in².
- Routing the slower speed control signals on the bottom layer allows for greater flexibility as these signal links usually have margin to tolerate discontinuities such as vias.

Suggested placement and routing of ISO1042-Q1 bypass capacitors and optional TVS diodes is shown in [Figure 34](#) and [Figure 35](#). In particular, place the V_{CC2} bypass capacitors on the top layer, as close to the device pins as possible, and complete the connection to the V_{CC2} and G_{ND2} pins without using vias. Note that the SOIC-16 variant needs two V_{CC2} bypass capacitor, one on each V_{CC2} pin.

If an additional supply voltage plane or signal layer is needed, add a second power or ground plane system to the stack to keep it symmetrical. This makes the stack mechanically stable and prevents it from warping. Also the power and ground plane of each power system can be placed closer together, thus increasing the high-frequency bypass capacitance significantly.

For detailed layout recommendations, refer to the [Digital Isolator Design Guide](#).

11.1.1 PCB Material

For digital circuit boards operating at less than 150 Mbps, (or rise and fall times greater than 1 ns), and trace lengths of up to 10 inches, use standard FR-4 UL94V-0 printed circuit board. This PCB is preferred over lower-cost alternatives because of lower dielectric losses at high frequencies, less moisture absorption, greater strength and stiffness, and the self-extinguishing flammability-characteristics.

11.2 Layout Example

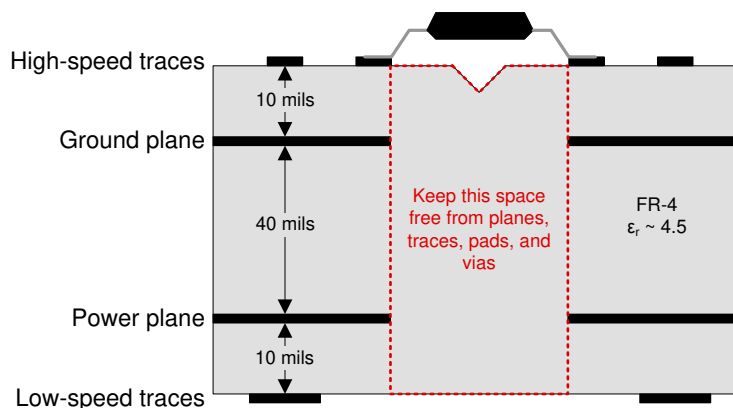

Figure 33. Recommended Layer Stack

Layout Example (接下页)



图 34. 16-DW Layout Example



图 35. 8-DWV Layout Example

12 器件和文档支持

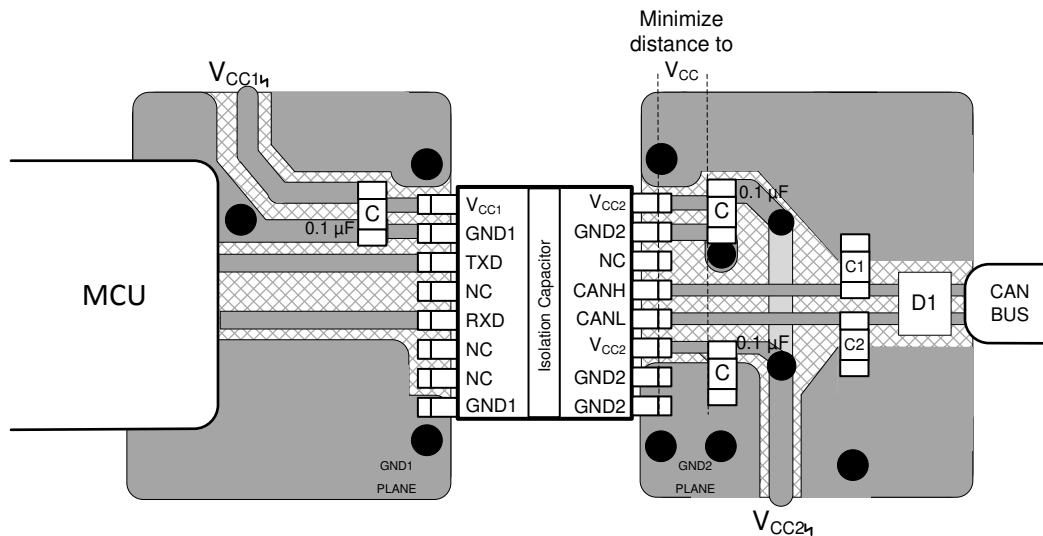
12.1 文档支持

12.1.1 相关文档

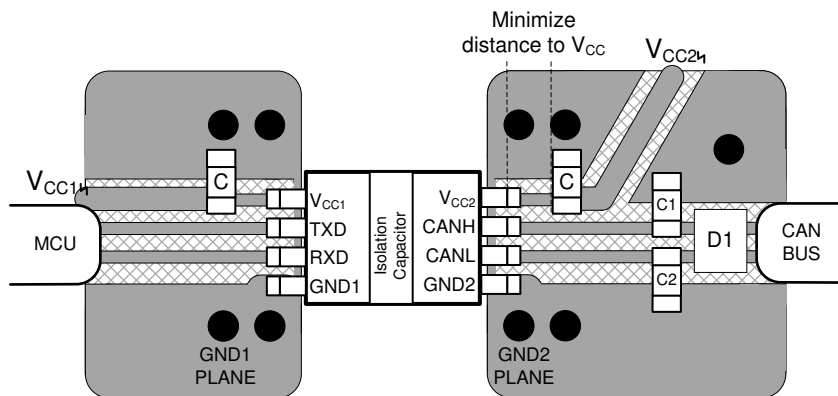
请参阅如下相关文档：

- 德州仪器 (TI), 《[数字隔离器设计指南](#)》
- 德州仪器 (TI), 《[ISO1042DW 隔离式 CAN 收发器评估模块](#)》用户指南
- 德州仪器 (TI), [在不牺牲性能或占用空间的情况下隔离您的 CAN 系统 TI 技术手册](#)
- 德州仪器 (TI), 《[隔离相关术语](#)》
- 德州仪器 (TI), [高电压增强型隔离：定义和测试方法](#)
- 德州仪器 (TI), [如何在隔离式 CAN 系统中隔离信号和电源 TI 技术手册](#)
- 德州仪器 (TI), 《[如何设计具有正确总线保护的隔离式 CAN 系统](#)》应用报告

12.2 接收文档更新通知

要接收文档更新通知，请导航至 ti.com 上的器件产品文件夹。单击右上角的通知我进行注册，即可每周接收产品信息更改摘要。有关更改的详细信息，请查阅已修订文档中包含的修订历史记录。

12.3 社区资源

[TI E2E™ support forums](#) are an engineer's go-to source for fast, verified answers and design help — straight from the experts. Search existing answers or ask your own question to get the quick design help you need.

Linked content is provided "AS IS" by the respective contributors. They do not constitute TI specifications and do not necessarily reflect TI's views; see TI's [Terms of Use](#).

12.4 商标

E2E is a trademark of Texas Instruments.

12.5 静电放电警告



ESD 可能会损坏该集成电路。德州仪器 (TI) 建议通过适当的预防措施处理所有集成电路。如果不遵守正确的处理措施和安装程序，可能会损坏集成电路。

ESD 的损坏小至导致微小的性能降级，大至整个器件故障。精密的集成电路可能更容易受到损坏，这是因为非常细微的参数更改都可能会导致器件与其发布的规格不相符。

12.6 Glossary

[SLYZ022](#) — *TI Glossary*.

This glossary lists and explains terms, acronyms, and definitions.

13 机械、封装和可订购信息

以下页面包含机械、封装和可订购信息。这些信息是指定器件的最新可用数据。数据如有变更，恕不另行通知，且不会对此文档进行修订。如需获取此数据表的浏览器版本，请查阅左侧的导航栏。

PACKAGING INFORMATION

Orderable Device	Status (1)	Package Type	Package Drawing	Pins	Package Qty	Eco Plan (2)	Lead finish/ Ball material (6)	MSL Peak Temp (3)	Op Temp (°C)	Device Marking (4/5)	Samples
ISO1042BQDWQ1	ACTIVE	SOIC	DW	16	40	RoHS & Green	NIPDAU	Level-3-260C-168 HR	-40 to 125	ISO1042BQ1	Samples
ISO1042BQDWRQ1	ACTIVE	SOIC	DW	16	2000	RoHS & Green	NIPDAU	Level-3-260C-168 HR	-40 to 125	ISO1042BQ1	Samples
ISO1042BQDWVQ1	ACTIVE	SOIC	DWV	8	64	RoHS & Green	NIPDAU	Level-3-260C-168 HR	-40 to 125	ISO1042B Q1	Samples
ISO1042BQDWVRQ1	ACTIVE	SOIC	DWV	8	1000	RoHS & Green	NIPDAU	Level-3-260C-168 HR	-40 to 125	ISO1042B Q1	Samples
ISO1042QDWQ1	ACTIVE	SOIC	DW	16	40	RoHS & Green	NIPDAU	Level-3-260C-168 HR	-40 to 125	ISO1042Q1	Samples
ISO1042QDWRQ1	ACTIVE	SOIC	DW	16	2000	RoHS & Green	NIPDAU	Level-3-260C-168 HR	-40 to 125	ISO1042Q1	Samples
ISO1042QDWVQ1	ACTIVE	SOIC	DWV	8	64	RoHS & Green	NIPDAU	Level-3-260C-168 HR	-40 to 125	ISO1042 Q1	Samples
ISO1042QDWVRQ1	ACTIVE	SOIC	DWV	8	1000	RoHS & Green	NIPDAU	Level-3-260C-168 HR	-40 to 125	ISO1042 Q1	Samples

(1) The marketing status values are defined as follows:

ACTIVE: Product device recommended for new designs.

LIFEBUY: TI has announced that the device will be discontinued, and a lifetime-buy period is in effect.

NRND: Not recommended for new designs. Device is in production to support existing customers, but TI does not recommend using this part in a new design.

PREVIEW: Device has been announced but is not in production. Samples may or may not be available.

OBSOLETE: TI has discontinued the production of the device.

(2) **RoHS:** TI defines "RoHS" to mean semiconductor products that are compliant with the current EU RoHS requirements for all 10 RoHS substances, including the requirement that RoHS substance do not exceed 0.1% by weight in homogeneous materials. Where designed to be soldered at high temperatures, "RoHS" products are suitable for use in specified lead-free processes. TI may reference these types of products as "Pb-Free".

RoHS Exempt: TI defines "RoHS Exempt" to mean products that contain lead but are compliant with EU RoHS pursuant to a specific EU RoHS exemption.

Green: TI defines "Green" to mean the content of Chlorine (Cl) and Bromine (Br) based flame retardants meet JS709B low halogen requirements of <=1000ppm threshold. Antimony trioxide based flame retardants must also meet the <=1000ppm threshold requirement.

(3) MSL, Peak Temp. - The Moisture Sensitivity Level rating according to the JEDEC industry standard classifications, and peak solder temperature.

(4) There may be additional marking, which relates to the logo, the lot trace code information, or the environmental category on the device.

⁽⁵⁾ Multiple Device Markings will be inside parentheses. Only one Device Marking contained in parentheses and separated by a "-" will appear on a device. If a line is indented then it is a continuation of the previous line and the two combined represent the entire Device Marking for that device.

⁽⁶⁾ Lead finish/Ball material - Orderable Devices may have multiple material finish options. Finish options are separated by a vertical ruled line. Lead finish/Ball material values may wrap to two lines if the finish value exceeds the maximum column width.

Important Information and Disclaimer:The information provided on this page represents TI's knowledge and belief as of the date that it is provided. TI bases its knowledge and belief on information provided by third parties, and makes no representation or warranty as to the accuracy of such information. Efforts are underway to better integrate information from third parties. TI has taken and continues to take reasonable steps to provide representative and accurate information but may not have conducted destructive testing or chemical analysis on incoming materials and chemicals. TI and TI suppliers consider certain information to be proprietary, and thus CAS numbers and other limited information may not be available for release.

In no event shall TI's liability arising out of such information exceed the total purchase price of the TI part(s) at issue in this document sold by TI to Customer on an annual basis.

TAPE AND REEL INFORMATION

QUADRANT ASSIGNMENTS FOR PIN 1 ORIENTATION IN TAPE



*All dimensions are nominal

Device	Package Type	Package Drawing	Pins	SPQ	Reel Diameter (mm)	Reel Width W1 (mm)	A0 (mm)	B0 (mm)	K0 (mm)	P1 (mm)	W (mm)	Pin1 Quadrant
ISO1042BQDWRQ1	SOIC	DW	16	2000	330.0	16.4	10.75	10.7	2.7	12.0	16.0	Q1
ISO1042BQDWVRQ1	SOIC	DWV	8	1000	330.0	16.4	12.05	6.15	3.3	16.0	16.0	Q1
ISO1042QDWRQ1	SOIC	DW	16	2000	330.0	16.4	10.75	10.7	2.7	12.0	16.0	Q1
ISO1042QDWVRQ1	SOIC	DWV	8	1000	330.0	16.4	12.05	6.15	3.3	16.0	16.0	Q1

TAPE AND REEL BOX DIMENSIONS

*All dimensions are nominal

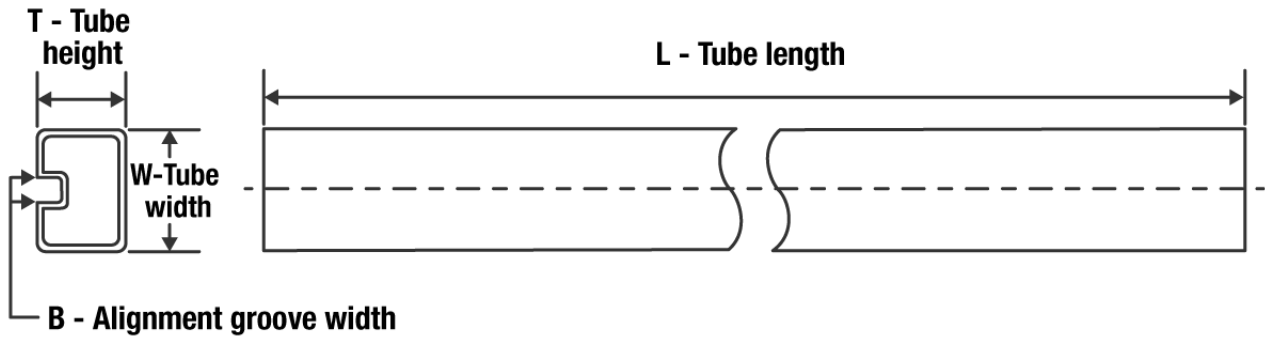
Device	Package Type	Package Drawing	Pins	SPQ	Length (mm)	Width (mm)	Height (mm)
ISO1042BQDWRQ1	SOIC	DW	16	2000	350.0	350.0	43.0
ISO1042BQDWVRQ1	SOIC	DWV	8	1000	350.0	350.0	43.0
ISO1042QDWRQ1	SOIC	DW	16	2000	350.0	350.0	43.0
ISO1042QDWVRQ1	SOIC	DWV	8	1000	350.0	350.0	43.0

TUBE

*All dimensions are nominal

Device	Package Name	Package Type	Pins	SPQ	L (mm)	W (mm)	T (μm)	B (mm)
ISO1042BQDWQ1	DW	SOIC	16	40	506.98	12.7	4826	6.6
ISO1042BQDWVQ1	DWV	SOIC	8	64	505.46	13.94	4826	6.6
ISO1042QDWQ1	DW	SOIC	16	40	506.98	12.7	4826	6.6
ISO1042QDWVQ1	DWV	SOIC	8	64	505.46	13.94	4826	6.6



DWV0008A

SOIC - 2.8 mm max height

SOIC

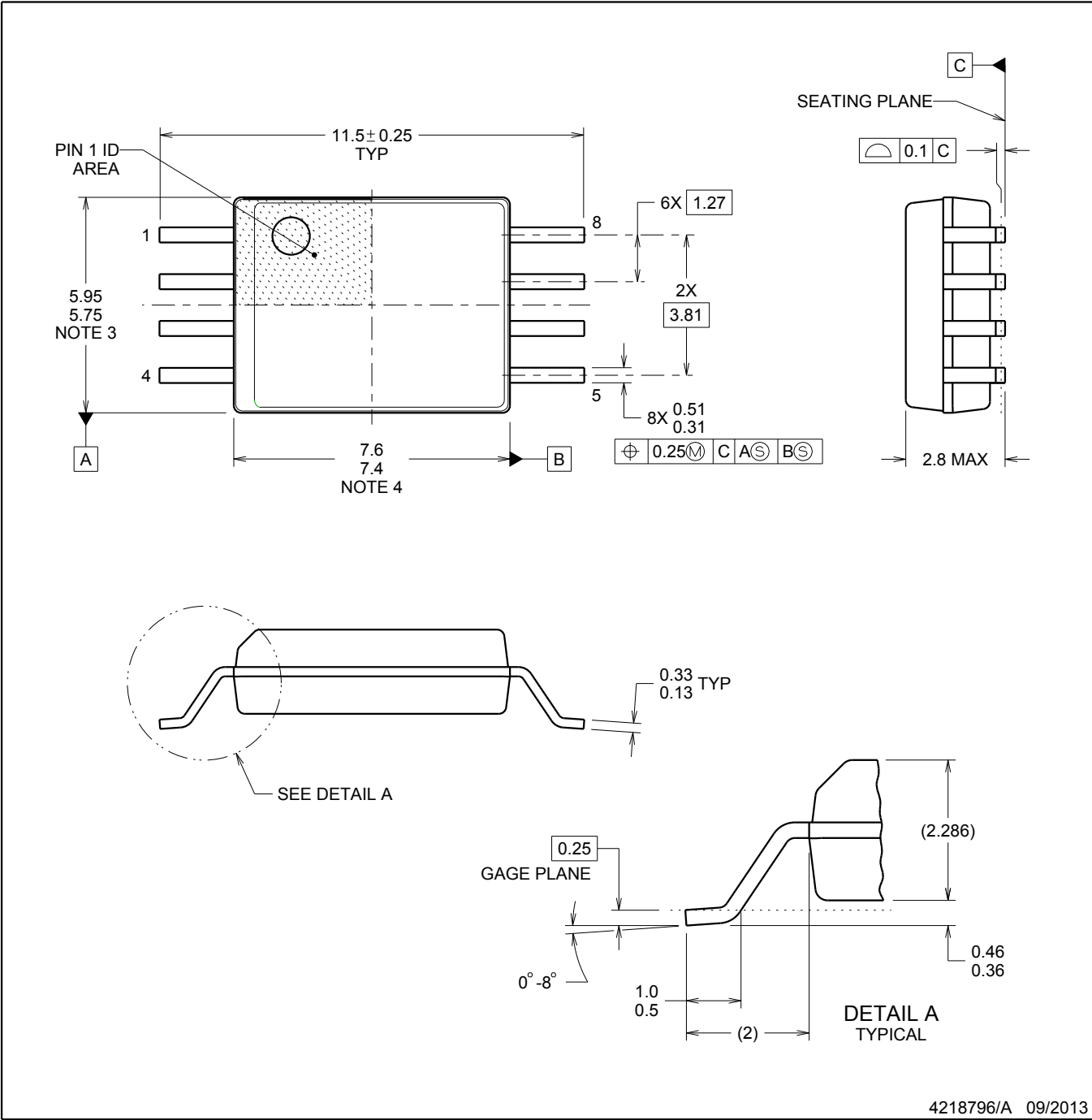

4218796/A 09/2013

NOTES:

- 1. All linear dimensions are in millimeters. Dimensions in parenthesis are for reference only. Dimensioning and tolerancing per ASME Y14.5M.
- 2. This drawing is subject to change without notice.
- 3. This dimension does not include mold flash, protrusions, or gate burrs. Mold flash, protrusions, or gate burrs shall not exceed 0.15 mm, per side.
- 4. This dimension does not include interlead flash. Interlead flash shall not exceed 0.25 mm, per side.



LAND PATTERN EXAMPLE
 9.1 mm NOMINAL CLEARANCE/CREEPAGE
 SCALE:6X

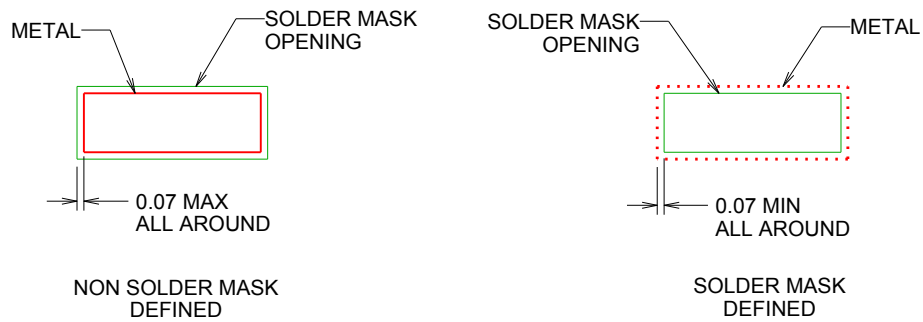

SOLDER MASK DETAILS

4218796/A 09/2013

NOTES: (continued)

- 5. Publication IPC-7351 may have alternate designs.
- 6. Solder mask tolerances between and around signal pads can vary based on board fabrication site.

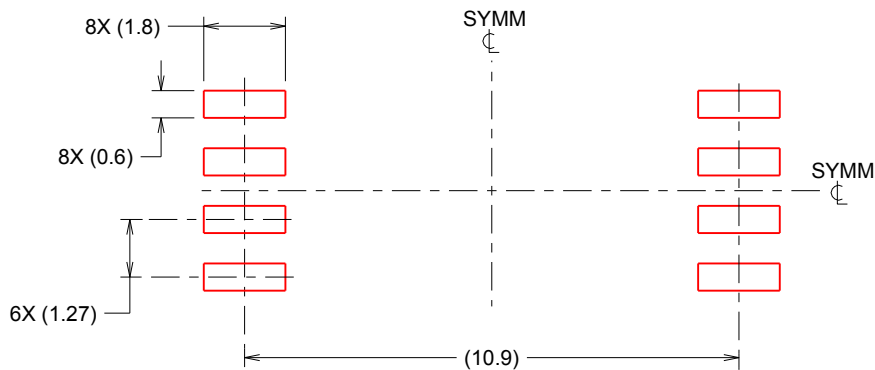

SOLDER PASTE EXAMPLE
 BASED ON 0.125 mm THICK STENCIL
 SCALE:6X

4218796/A 09/2013

NOTES: (continued)

- 7. Laser cutting apertures with trapezoidal walls and rounded corners may offer better paste release. IPC-7525 may have alternate design recommendations.
- 8. Board assembly site may have different recommendations for stencil design.

GENERIC PACKAGE VIEW

DW 16

SOIC - 2.65 mm max height

7.5 x 10.3, 1.27 mm pitch

SMALL OUTLINE INTEGRATED CIRCUIT

This image is a representation of the package family, actual package may vary.
Refer to the product data sheet for package details.



4224780/A



DW0016B

PACKAGE OUTLINE

SOIC - 2.65 mm max height

SOIC



4221009/B 07/2016

NOTES:

1. All linear dimensions are in millimeters. Dimensions in parenthesis are for reference only. Dimensioning and tolerancing per ASME Y14.5M.
2. This drawing is subject to change without notice.
3. This dimension does not include mold flash, protrusions, or gate burrs. Mold flash, protrusions, or gate burrs shall not exceed 0.15 mm, per side.
4. This dimension does not include interlead flash. Interlead flash shall not exceed 0.25 mm, per side.
5. Reference JEDEC registration MS-013.

EXAMPLE BOARD LAYOUT

DW0016B

SOIC - 2.65 mm max height

SOIC



LAND PATTERN EXAMPLE
SCALE:4X

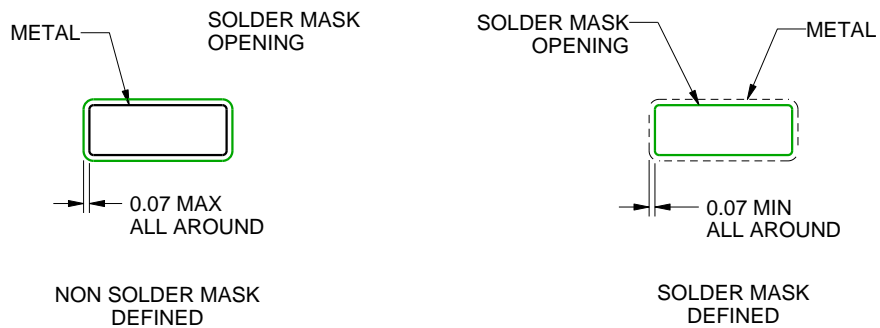

SOLDER MASK DETAILS

4221009/B 07/2016

NOTES: (continued)

- 6. Publication IPC-7351 may have alternate designs.
- 7. Solder mask tolerances between and around signal pads can vary based on board fabrication site.

EXAMPLE STENCIL DESIGN

DW0016B

SOIC - 2.65 mm max height

SOIC



NOTES: (continued)

8. Laser cutting apertures with trapezoidal walls and rounded corners may offer better paste release. IPC-7525 may have alternate design recommendations.
9. Board assembly site may have different recommendations for stencil design.

重要声明和免责声明

TI“按原样”提供技术和可靠性数据（包括数据表）、设计资源（包括参考设计）、应用或其他设计建议、网络工具、安全信息和其他资源，不保证没有瑕疵且不做任何明示或暗示的担保，包括但不限于对适销性、某特定用途方面的适用性或不侵犯任何第三方知识产权的暗示担保。

这些资源可供使用 TI 产品进行设计的熟练开发人员使用。您将自行承担以下全部责任：(1) 针对您的应用选择合适的 TI 产品，(2) 设计、验证并测试您的应用，(3) 确保您的应用满足相应标准以及任何其他功能安全、信息安全、监管或其他要求。

这些资源如有变更，恕不另行通知。TI 授权您仅可将这些资源用于研发本资源所述的 TI 产品的应用。严禁对这些资源进行其他复制或展示。您无权使用任何其他 TI 知识产权或任何第三方知识产权。您应全额赔偿因在这些资源的使用中对 TI 及其代表造成的任何索赔、损害、成本、损失和债务，TI 对此概不负责。

TI 提供的产品受 [TI 的销售条款](#) 或 [ti.com](#) 上其他适用条款/TI 产品随附的其他适用条款的约束。TI 提供这些资源并不会扩展或以其他方式更改 TI 针对 TI 产品发布的适用的担保或担保免责声明。

TI 反对并拒绝您可能提出的任何其他或不同的条款。

邮寄地址：Texas Instruments, Post Office Box 655303, Dallas, Texas 75265

Copyright © 2022，德州仪器 (TI) 公司

X-ON Electronics

Largest Supplier of Electrical and Electronic Components

Click to view similar products for [CAN Interface IC category](#):

Click to view products by [Texas Instruments manufacturer](#):

Other Similar products are found below :

[PCA82C250T/N4](#) [UJA1169TK/3Z](#) [TLE7251VLE](#) [UM3608QA](#) [TJA1055T/3/1](#) [TJA1057BT/0Z](#) [TJA1042BT/0Z](#) [TJA1044BT/0Z](#)
[LTC2875IDD#TRPBF](#) [TLE9251VLE](#) [TLE9250VLE](#) [MCP251863T-E/SS](#) [ATA6570-GNQW1](#) [UJA1169TK/3](#) [TJA1448BTK/0Z](#)
[UJA1169ATK/X/FZ](#) [TJA1442ATK/0Z](#) [UJA1169TK/F](#) [TJR1443AT/0Z](#) [UJA1169TK/X/FZ](#) [TJA1442BT/0Z](#) [TJA1152BT/0Z](#)
[TJA1441BTK/0Z](#) [TCAN1463DMTRQ1](#) [TCAN1057AVDDFRQ1](#) [TCAN1462VDRBRQ1](#) [TCAN1043ADMTRQ1](#) [TCAN1043ADYYRQ1](#)
[TJA1042CT/0Z](#) [TCAN1057AEVDRQ1](#) [TJR1442ATK/0Z](#) [TCAN1043ADRQ1](#) [TLE9252VSK](#) [TLE9250XSJ](#) [CA-IF1042LS-Q1](#)
[SN65HVD1050DR-JSM](#) [MCP2562T-E/MFVAO](#) [TJA1050T-JSM](#) [SIT1042AQTK](#) [TJA1040T-JSM](#) [SSIT1050T](#) [SIT1051ATK/3](#)
[TJA1051AT/0Z](#) [SN65HVD1040DR-JSM](#) [SSIT1040T](#) [CA-IF1042LVS-Q1](#) [SIT3232EEWE](#) [HGA1042M-3/TR](#) [BIN1051S-C](#) [TLE9471ES V33](#)