

EMC 性能优异的 ISO676x-Q1 通用六通道自动增强型数字隔离器

1 特性

- 具有符合 AEC-Q100 标准的下列特性：
 - 器件温度等级 1：-40°C 至 +125°C 环境温度工作温度范围
- 满足 VDA320 隔离要求
- 50Mbps 数据速率
- 稳健可靠的隔离栅：
 - 在 1500 V_{RMS} 工作电压下具有超长的寿命
 - 隔离等级高达 5000 V_{RMS}
 - 浪涌能力高达 10kV
 - CMTI 典型值为 ±150 kV/μs
- 宽电源电压范围：1.71V 到 1.89V 和 2.25V 到 5.5V
- 1.71V 至 5.5V 电平转换
- 默认输出高电平 (ISO676x-Q1) 和低电平 (ISO676xF-Q1) 选项
- 1Mbps 时的每通道电流典型值为 1.6mA
- 低传播延迟：11ns (典型值)
- 优异的电磁兼容性 (EMC)
 - 系统级 ESD、EFT 和浪涌抗扰性
 - 低辐射
- 宽体 SOIC (DW-16) 封装
- 安全相关认证 (待审核)：
 - DIN VDE V 0884-11:2017-01
 - UL 1577 组件认证计划
 - IEC 62368-1、IEC 61010-1、IEC 60601-1 和 GB 4943.1-2011 认证

2 应用

- 混合动力、电动和动力总成系统 (EV/HEV)
 - 电池管理系统 (BMS)
 - 车载充电器
 - 直流/直流转换器
 - 逆变器和电机控制

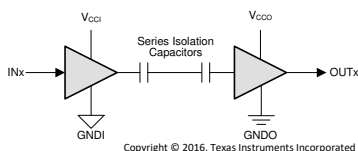

V_{CCI} = 输入电源, V_{CCO} = 输出电源
GNDI = 输入接地, GNDO = 输出接地

简化版原理图

3 说明

ISO676x-Q1 器件是高性能六通道数字隔离器, 可提供符合 UL 1577 的 5000 V_{RMS} 隔离额定值, 非常适合具有此类需求的成本敏感型应用。这些器件还通过了 VDE、TUV、CSA 和 CQC 认证。

在隔离 CMOS 或者 LVCMOS 数字 I/O 的同时, ISO676x-Q1 器件可提供高电磁抗扰度和低辐射, 同时具备低功耗特性。每条隔离通道的逻辑输入和输出缓冲器均由 TI 的双电容二氧化硅 (SiO₂) 绝缘栅相隔离。ISO676x 系列器件采用所有可能的引脚配置, 因此所有六个通道都可以处于同一方向, 或者一个、两个或三个通道处于反向, 而其余通道处于正向。如果输入功率或信号出现损失, 不带后缀 F 的器件默认输出高电平, 带后缀 F 的器件默认输出低电平。更多详细信息, 请参见器件功能模式部分。

这些器件与隔离式电源结合使用, 有助于防止 CAN 和 LIN 等数据总线上的噪声电流损坏敏感电路。凭借创新型芯片设计和布线技术, ISO676x-Q1 器件的电磁兼容性得到了显著增强, 可缓解系统级 ESD、EFT 和浪涌问题并符合辐射标准。ISO676x-Q1 系列器件采用 16 引脚 SOIC 宽体 (DW) 封装, 是对前几代器件的引脚到引脚的升级。

器件描述

器件型号 (1)	封装	封装尺寸
ISO6760-Q1、ISO6760F-Q1、ISO6761-Q1、ISO6761F-Q1、ISO6762-Q1、ISO6762F-Q1、ISO6763-Q1、ISO6763F-Q1	SOIC (DW)	10.30mm x 7.50mm

(1) 如需了解所有可用封装, 请参阅数据表末尾的可订购产品附录。



Table of Contents

1 特性	1	6.19 Insulation Characteristics Curves.....	22
2 应用	1	6.20 Typical Characteristics.....	23
3 说明	1	7 Parameter Measurement Information	25
4 Revision History	2	8 Detailed Description	26
5 Pin Configuration and Functions	3	8.1 Overview.....	26
6 Specifications	5	8.2 Functional Block Diagram.....	26
6.1 Absolute Maximum Ratings.....	5	8.3 Feature Description.....	27
6.2 ESD Ratings.....	5	8.4 Device Functional Modes.....	28
6.3 Recommended Operating Conditions.....	6	9 Application and Implementation	29
6.4 Thermal Information.....	7	9.1 Application Information.....	29
6.5 Power Ratings.....	7	9.2 Typical Application.....	30
6.6 Insulation Specifications.....	8	10 Power Supply Recommendations	33
6.7 Safety-Related Certifications.....	9	11 Layout	34
6.8 Safety Limiting Values.....	9	11.1 Layout Guidelines.....	34
Electrical Characteristics—5-V Supply.....	10	11.2 Layout Example.....	35
6.9 Supply Current Characteristics—5-V Supply.....	10	12 Device and Documentation Support	36
6.10 Electrical Characteristics—3.3-V Supply.....	12	12.1 Documentation Support.....	36
6.11 Supply Current Characteristics—3.3-V Supply.....	12	12.2 Receiving Notification of Documentation Updates.....	36
6.12 Electrical Characteristics—2.5-V Supply.....	14	12.3 支持资源.....	36
6.13 Supply Current Characteristics—2.5-V Supply.....	14	12.4 Trademarks.....	36
Electrical Characteristics—1.8-V Supply.....	16	12.5 Electrostatic Discharge Caution.....	36
6.14 Supply Current Characteristics—1.8-V Supply.....	16	12.6 术语表.....	36
6.15 Switching Characteristics—5-V Supply.....	18	13 Mechanical, Packaging, and Orderable Information	36
6.16 Switching Characteristics—3.3-V Supply.....	19	13.1 Package Option Addendum.....	40
6.17 Switching Characteristics—2.5-V Supply.....	20	13.2 Tape and Reel Information.....	41
6.18 Switching Characteristics—1.8-V Supply.....	21		

4 Revision History

注：以前版本的页码可能与当前版本的页码不同

Changes from Revision A (November 2021) to Revision B (May 2022)	Page
• Updated CMTI spec for 5-V, 3.3-V and 2.5-V supply conditions.....	5

Changes from Revision * (August 2021) to Revision A (November 2021)	Page
• 将器件状态更新为“量产数据”.....	1

5 Pin Configuration and Functions



图 5-1. ISO6760-Q1 DW Package 16-Pin SOIC-WB Top View



图 5-2. ISO6761-Q1 DW Package 16-Pin SOIC-WB Top View

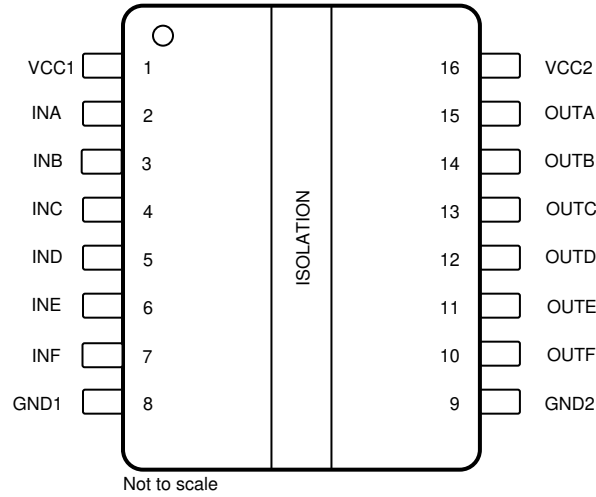

图 5-3. ISO6762-Q1 DW Package 16-Pin SOIC-WB Top View

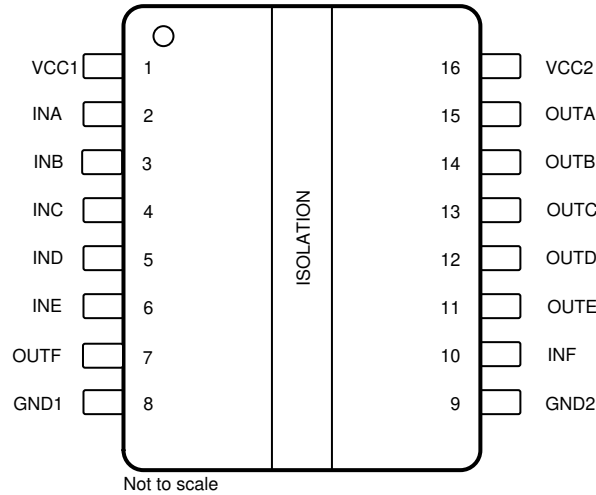

图 5-4. ISO6763-Q1 DW Package 16-Pin SOIC-WB Top View

表 5-1. Pin Functions

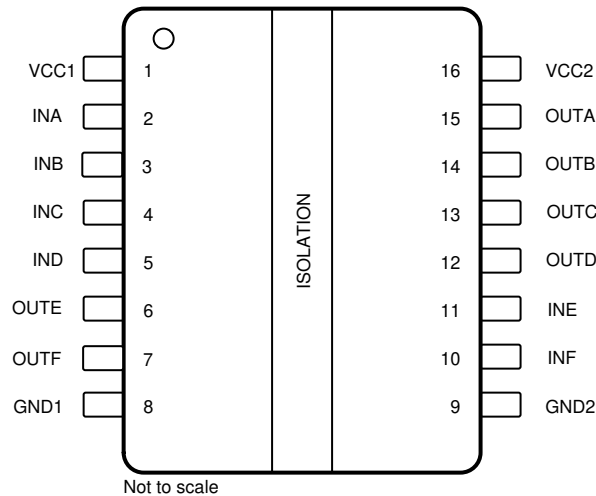
NAME	PIN NO.				I/O	DESCRIPTION
	ISO6760-Q1	ISO6761-Q1	ISO6762-Q1	ISO6763-Q1		
GND1	8	8	8	8	—	Ground connection for V_{CC1}
GND2	9	9	9	9	—	Ground connection for V_{CC2}
INA	2	2	2	2	I	Input, channel A
INB	3	3	3	3	I	Input, channel B
INC	4	4	4	4	I	Input, channel C
IND	5	5	5	12	I	Input, channel D
INE	6	6	11	11	I	Input, channel E
INF	7	10	10	10	I	Input, channel F
OUTA	15	15	15	15	O	Output, channel A
OUTB	14	14	14	14	O	Output, channel B
OUTC	13	13	13	13	O	Output, channel C
OUTD	12	12	12	5	O	Output, channel D
OUTE	11	11	6	6	O	Output, channel E
OUTF	10	7	7	7	O	Output, channel F
V_{CC1}	1	1	1	1	—	Power supply, side 1
V_{CC2}	16	16	16	16	—	Power supply, side 2

6 Specifications

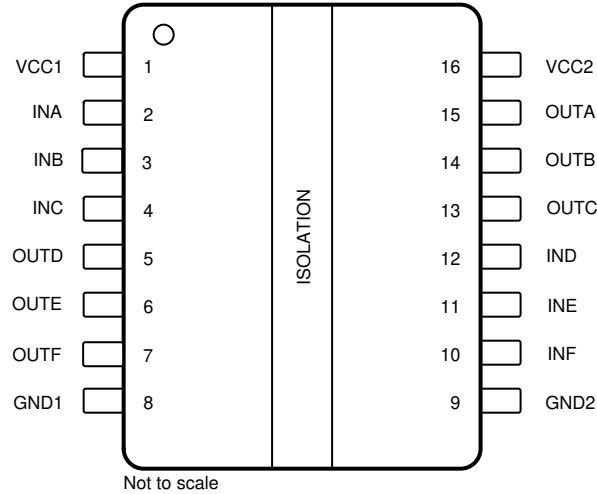
6.1 Absolute Maximum Ratings

See⁽¹⁾

		MIN	MAX	UNIT
Supply Voltage ⁽²⁾	V _{CC1} to GND1	-0.5	6	V
	V _{CC2} to GND2	-0.5	6	
Input/Output Voltage	IN _x to GND _x	-0.5	V _{CCX} + 0.5 ⁽³⁾	V
	OUT _x to GND _x	-0.5	V _{CCX} + 0.5 ⁽³⁾	
Output Current	I _o	-15	15	mA
Temperature	Operating junction temperature, T _J		150	°C
	Storage temperature, T _{stg}	-65	150	°C

- (1) Stresses beyond those listed under Absolute Maximum Ratings may cause permanent damage to the device. These are stress ratings only, which do not imply functional operation of the device at these or any other conditions beyond those indicated under Recommended Operating Conditions. Exposure to absolute-maximum-rated conditions for extended periods may affect device reliability.
- (2) All voltage values except differential I/O bus voltages are with respect to the local ground terminal (GND1 or GND2) and are peak voltage values
- (3) Maximum voltage must not exceed 6 V.

6.2 ESD Ratings

(1) (2)

			VALUE	UNIT
V _(ESD)	Electrostatic discharge	Human body model (HBM), per ANSI/ESDA/JEDEC JS-001, all pins ⁽¹⁾	±2000	V
		Charged device model (CDM), per JEDEC specification JESD22-C101, all pins ⁽²⁾	±1500	

- (1) JEDEC document JEP155 states that 500-V HBM allows safe manufacturing with a standard ESD control process.
- (2) JEDEC document JEP157 states that 250-V CDM allows safe manufacturing with a standard ESD control process.

6.3 Recommended Operating Conditions

		MIN	NOM	MAX	UNIT	
V _{CC1} ⁽¹⁾	Supply Voltage Side 1 ⁽³⁾	1.71		1.89	V	
V _{CC1} ⁽¹⁾	Supply Voltage Side 1 ⁽³⁾	2.25		5.5	V	
V _{CC2} ⁽¹⁾	Supply Voltage Side 2 ⁽³⁾	1.71		1.89	V	
V _{CC2} ⁽¹⁾	Supply Voltage Side 2 ⁽³⁾	2.25		5.5	V	
V _{CC} (UVLO+)	UVLO threshold when supply voltage is rising		1.53	1.71	V	
V _{CC} (UVLO-)	UVLO threshold when supply voltage is falling	1.1	1.41		V	
V _{hys} (UVLO)	Supply voltage UVLO hysteresis	0.08	0.13		V	
V _{IH}	High level Input voltage	0.7 x V _{CC1} ⁽²⁾		V _{CC1}	V	
V _{IL}	Low level Input voltage	0	0.3 x V _{CC1}		V	
I _{OH}	High level output current	V _{CCO} ⁽²⁾ = 5 V			-4	mA
		V _{CCO} = 3.3 V			-2	mA
		V _{CCO} = 2.5 V			-1	mA
		V _{CCO} = 1.8 V			-1	mA
I _{OL}	Low level output current	V _{CCO} = 5 V			4	mA
		V _{CCO} = 3.3 V			2	mA
		V _{CCO} = 2.5 V			1	mA
		V _{CCO} = 1.8 V			1	mA
DR	Data Rate	0		50	Mbps	
T _A	Ambient temperature	-40	25	125	°C	

(1) V_{CC1} and V_{CC2} can be set independent of one another

(2) V_{CC1} = Input-side V_{CC}; V_{CCO} = Output-side V_{CC}

(3) The channel outputs are in undetermined state when 1.89 V < V_{CC1}, V_{CC2} < 2.25 V and 1.05 V < V_{CC1}, V_{CC2} < 1.71 V

6.4 Thermal Information

THERMAL METRIC ⁽¹⁾		ISO676x	UNIT
		DW (SOIC)	
		16 PINS	
$R_{\theta JA}$	Junction-to-ambient thermal resistance	68.8	°C/W
$R_{\theta JC(top)}$	Junction-to-case (top) thermal resistance	31.8	°C/W
$R_{\theta JB}$	Junction-to-board thermal resistance	32.7	°C/W
ψ_{JT}	Junction-to-top characterization parameter	13.5	°C/W
ψ_{JB}	Junction-to-board characterization parameter	32.1	°C/W
$R_{\theta JC(bot)}$	Junction-to-case (bottom) thermal resistance	n/a	°C/W

6.5 Power Ratings

PARAMETER		TEST CONDITIONS	MIN	TYP	MAX	UNIT
ISO6760						
P_D	Maximum power dissipation (both sides)	$V_{CC1} = V_{CC2} = 5.5\text{ V}$, $T_J = 150^\circ\text{C}$, $C_L = 15\text{ pF}$, Input a 25-MHz 50% duty cycle square wave			192	mW
P_{D1}	Maximum power dissipation (side-1)				45	mW
P_{D2}	Maximum power dissipation (side-2)				147	mW
ISO6761						
P_D	Maximum power dissipation (both sides)	$V_{CC1} = V_{CC2} = 5.5\text{ V}$, $T_J = 150^\circ\text{C}$, $C_L = 15\text{ pF}$, Input a 25-MHz 50% duty cycle square wave			197	mW
P_{D1}	Maximum power dissipation (side-1)				63	mW
P_{D2}	Maximum power dissipation (side-2)				134	mW
ISO6762						
P_D	Maximum power dissipation (both sides)	$V_{CC1} = V_{CC2} = 5.5\text{ V}$, $T_J = 150^\circ\text{C}$, $C_L = 15\text{ pF}$, Input a 25-MHz 50% duty cycle square wave			197	mW
P_{D1}	Maximum power dissipation (side-1)				81	mW
P_{D2}	Maximum power dissipation (side-2)				116	mW
ISO6763						
P_D	Maximum power dissipation (both sides)	$V_{CC1} = V_{CC2} = 5.5\text{ V}$, $T_J = 150^\circ\text{C}$, $C_L = 15\text{ pF}$, Input a 25-MHz 50% duty cycle square wave			196	mW
P_{D1}	Maximum power dissipation (side-1)				98	mW
P_{D2}	Maximum power dissipation (side-2)				98	mW

6.6 Insulation Specifications

PARAMETER		TEST CONDITIONS	VALUE	UNIT
			DW-16	
CLR	External clearance ⁽¹⁾	Shortest terminal-to-terminal distance through air	>8	mm
CPG	External creepage ⁽¹⁾	Shortest terminal-to-terminal distance across the package surface	>8	mm
DTI	Distance through the insulation	Minimum internal gap (internal clearance)	>17	um
CTI	Comparative tracking index	DIN EN 60112 (VDE 0303-11); IEC 60112	>600	V
	Material group	According to IEC 60664-1	I	
	Overvoltage category per IEC 60664-1	Rated mains voltage $\leq 600 V_{RMS}$	I-IV	
		Rated mains voltage $\leq 1000 V_{RMS}$	I-III	
DIN VDE V 0884-11:2017-01⁽²⁾				
V _{IORM}	Maximum repetitive peak isolation voltage	AC voltage (bipolar)	2121	V _{PK}
V _{IOWM}	Maximum working isolation voltage	AC voltage; Time dependent dielectric breakdown (TDDB) Test; See Fig 9-8	1500	V _{RMS}
		DC voltage	2121	V _{DC}
V _{IOTM}	Maximum transient isolation voltage	V _{TEST} = V _{IOTM} , t = 60 s (qualification); V _{TEST} = 1.2 x V _{IOTM} , t = 1 s (100% production)	7071	V _{PK}
V _{IOSM}	Maximum surge isolation voltage ⁽³⁾	Test method per IEC 62368-1, 1.2/50 μ s waveform, V _{TEST} = 1.6 x V _{IOSM} = 10,000 V _{PK} (qualification)	6250	V _{PK}
q _{pd}	Apparent charge ⁽⁴⁾	Method a, After Input-output safety test subgroup 2/3, V _{ini} = V _{IOTM} , t _{ini} = 60 s; V _{pd(m)} = 1.2 x V _{IORM} , t _m = 10 s	≤ 5	pC
		Method a, After environmental tests subgroup 1, V _{ini} = V _{IOTM} , t _{ini} = 60 s; V _{pd(m)} = 1.6 x V _{IORM} , t _m = 10 s	≤ 5	
		Method b1; At routine test (100% production) and preconditioning (type test) V _{ini} = 1.2 x V _{IOTM} , t _{ini} = 1 s; V _{pd(m)} = 1.875 x V _{IORM} , t _m = 1 s	≤ 5	
C _{IO}	Barrier capacitance, input to output ⁽⁵⁾	V _{IO} = 0.4 x sin (2 π ft), f = 1 MHz	~1	pF
R _{IO}	Isolation resistance ⁽⁵⁾	V _{IO} = 500 V, T _A = 25°C	>10 ¹²	Ω
		V _{IO} = 500 V, 100°C \leq T _A \leq 125°C	>10 ¹¹	
		V _{IO} = 500 V at T _S = 150°C	>10 ⁹	
	Pollution degree		2	
	Climatic category		40/125/21	
UL 1577				
V _{ISO}	Maximum withstanding isolation voltage	V _{TEST} = V _{ISO} , t = 60 s (qualification), V _{TEST} = 1.2 x V _{ISO} , t = 1 s (100% production)	5000	V _{RMS}

- (1) Creepage and clearance requirements should be applied according to the specific equipment isolation standards of an application. Care should be taken to maintain the creepage and clearance distance of a board design to ensure that the mounting pads of the isolator on the printed-circuit board do not reduce this distance. Creepage and clearance on a printed-circuit board become equal in certain cases. Techniques such as inserting grooves and/or ribs on a printed-circuit board are used to help increase these specifications.
- (2) This coupler is suitable for *safe electrical insulation* only within the safety ratings. Compliance with the safety ratings shall be ensured by means of suitable protective circuits.
- (3) Testing is carried out in air or oil to determine the intrinsic surge immunity of the isolation barrier.
- (4) Apparent charge is electrical discharge caused by a partial discharge (pd).
- (5) All pins on each side of the barrier tied together creating a two-terminal device.

6.7 Safety-Related Certifications

VDE	CSA	UL	CQC	TUV
Plan to certify according to DIN VDE V 0884-11:2017-01	Plan to certify according to IEC 62368-1, IEC 61010-1 and IEC 60601-1	Plan to certify according to UL 1577 Component Recognition Program	Plan to certify according to GB4943.1-2011	Plan to certify according to EN 61010-1:2010/A1:2019 and EN 62368-1:2014
Maximum transient isolation voltage, 7071 V _{PK} ; Maximum repetitive peak isolation voltage, 2121 V _{PK} ; Maximum surge isolation voltage, 6250 V _{PK}	600 V _{RMS} reinforced insulation per CSA 62368-1:19 and IEC 62368-1:2018; 600 V _{RMS} reinforced insulation per CSA 61010-1-12+A1 and IEC 61010-1 3rd Ed (pollution degree 2, material group I); 2 MOPP (Means of Patient Protection) per CSA 60601-1-14 and IEC 60601-1 Ed.3+A1, 250 V _{RMS} max working voltage	Single protection, 5000 V _{RMS}	Reinforced insulation, Altitude ≤ 5000 m, Tropical Climate, 700 V _{RMS} maximum working voltage	5000 V _{RMS} reinforced insulation per EN 61010-1:2010/A1:2019 and EN 62368-1:2014 up to working voltage of 600 V _{RMS}
Certificate planned	Certificate planned	Certificate planned	Certificate planned	Certificate planned

6.8 Safety Limiting Values

Safety limiting⁽¹⁾ intends to minimize potential damage to the isolation barrier upon failure of input or output circuitry.

PARAMETER		TEST CONDITIONS	MIN	TYP	MAX	UNIT
DW-16 PACKAGE						
I _S	Safety input, output, or supply current ⁽¹⁾	R _{θJA} = 68.8°C/W, V _I = 5.5 V, T _J = 150°C, T _A = 25°C			330	mA
		R _{θJA} = 68.8°C/W, V _I = 3.6 V, T _J = 150°C, T _A = 25°C			504	mA
		R _{θJA} = 68.8°C/W, V _I = 2.75 V, T _J = 150°C, T _A = 25°C			660	mA
		R _{θJA} = 68.8°C/W, V _I = 1.89 V, T _J = 150°C, T _A = 25°C			956	mA
P _S	Safety input, output, or total power ⁽¹⁾	R _{θJA} = 68.8°C/W, T _J = 150°C, T _A = 25°C			1820	mW
T _S	Maximum safety temperature ⁽¹⁾				150	°C

- (1) The maximum safety temperature, T_S, has the same value as the maximum junction temperature, T_J, specified for the device. The I_S and P_S parameters represent the safety current and safety power respectively. The maximum limits of I_S and P_S should not be exceeded. These limits vary with the ambient temperature, T_A.
The junction-to-air thermal resistance, R_{θJA}, in the table is that of a device installed on a high-K test board for leaded surface-mount packages. Use these equations to calculate the value for each parameter:
T_J = T_A + R_{θJA} × P, where P is the power dissipated in the device.
T_{J(max)} = T_S = T_A + R_{θJA} × P_S, where T_{J(max)} is the maximum allowed junction temperature.
P_S = I_S × V_I, where V_I is the maximum input voltage.

Electrical Characteristics—5-V Supply

over recommended operating conditions (unless otherwise noted)

PARAMETER		TEST CONDITIONS	MIN	TYP	MAX	UNIT
V _{OH}	High-level output voltage	I _{OH} = -4 mA; See 图 7-1	V _{CCO} - 0.4			V
V _{OL}	Low-level output voltage	I _{OL} = 4 mA; See 图 7-1			0.4	V
V _{IT+(IN)}	Rising input switching threshold			0.7 x V _{CC1} ⁽¹⁾		V
V _{IT-(IN)}	Falling input switching threshold		0.3 x V _{CC1}			V
V _{I(HYS)}	Input threshold voltage hysteresis		0.1 x V _{CC1}			V
I _{IH}	High-level input current	V _{IH} = V _{CC1} ⁽¹⁾ at INx			10	μA
I _{IL}	Low-level input current	V _{IL} = 0 V at INx	-10			μA
CMTI	Common mode transient immunity	V _I = V _{CC} or 0 V, V _{CM} = 1200 V; See 图 7-3	100	150		kV/us
C _i	Input Capacitance ⁽²⁾	V _I = V _{CC} / 2 + 0.4 × sin(2 π ft), f = 2 MHz, V _{CC} = 5 V		2.8		pF

(1) V_{CC1} = Input-side V_{CC}; V_{CCO} = Output-side V_{CC}

(2) Measured from input pin to same side ground.

6.9 Supply Current Characteristics—5-V Supply

V_{CC1} = V_{CC2} = 5 V ±10% (over recommended operating conditions unless otherwise noted).

PARAMETER	TEST CONDITIONS		SUPPLY CURRENT	MIN	TYP	MAX	UNIT
ISO6760							
Supply current - DC signal	V _I = V _{CC1} (ISO6760); V _I = 0 V (ISO6760 with F suffix)		I _{CC1}		2.2	2.8	mA
			I _{CC2}		3.1	5.2	
	V _I = 0 V (ISO6760); V _I = V _{CC1} (ISO6760 with F suffix)		I _{CC1}		8.3	11.1	
			I _{CC2}		3.4	5.7	
Supply current - AC signal	All channels switching with square wave clock input; CL = 15 pF	1 Mbps	I _{CC1}		5.3	7.0	
			I _{CC2}		3.7	5.9	
		10 Mbps	I _{CC1}		5.4	7.2	
			I _{CC2}		7.0	9.7	
		50 Mbps	I _{CC1}		6.3	8.1	
			I _{CC2}		21.9	26.6	
ISO6761							
Supply current - DC signal	V _I = V _{CC1} (ISO6761); V _I = 0 V (ISO6761 with F suffix)		I _{CC1}		2.4	3.5	mA
			I _{CC2}		3.6	5.8	
	V _I = 0 V (ISO6761); V _I = V _{CC1} (ISO6761 with F suffix)		I _{CC1}		7.6	10.4	
			I _{CC2}		5.0	7.6	
Supply current - AC signal	All channels switching with square wave clock input; CL = 15 pF	1 Mbps	I _{CC1}		5.1	7.0	
			I _{CC2}		4.6	7.0	
		10 Mbps	I _{CC1}		5.8	7.8	
			I _{CC2}		7.4	10.2	
		50 Mbps	I _{CC1}		8.9	11.4	
			I _{CC2}		20.0	24.4	
ISO6762							

$V_{CC1} = V_{CC2} = 5\text{ V} \pm 10\%$ (over recommended operating conditions unless otherwise noted).

PARAMETER	TEST CONDITIONS		SUPPLY CURRENT	MIN	TYP	MAX	UNIT
Supply current - DC signal	$V_I = V_{CC1}$ (ISO6762); $V_I = 0\text{ V}$ (ISO6762 with F suffix)		I_{CC1}		2.7	4.1	mA
			I_{CC2}		3.3	5.2	
	$V_I = 0\text{ V}$ (ISO6762); $V_I = V_{CC1}$ (ISO6762 with F suffix)		I_{CC1}		6.9	9.7	
			I_{CC2}		5.6	8.3	
Supply current - AC signal	All channels switching with square wave clock input; $C_L = 15\text{ pF}$	1 Mbps	I_{CC1}		5	7	
			I_{CC2}		4.7	7	
		10 Mbps	I_{CC1}		6.2	8.4	
			I_{CC2}		7	9.6	
		50 Mbps	I_{CC1}		11.7	14.6	
			I_{CC2}		17.2	21.1	
ISO6763							
Supply current - DC signal	$V_I = V_{CCI}$ (ISO6763); $V_I = 0\text{ V}$ (ISO6763 with F suffix)		I_{CC1}, I_{CC2}		3	4.7	mA
	$V_I = 0\text{ V}$ (ISO6763); $V_I = V_{CCI}$ (ISO6763 with F suffix)		I_{CC1}, I_{CC2}		6.3	9	
Supply current - AC signal	All channels switching with square wave clock input; $C_L = 15\text{ pF}$	1 Mbps	I_{CC1}, I_{CC2}		4.8	7	
			I_{CC1}, I_{CC2}		6.6	9	
		50 Mbps	I_{CC1}, I_{CC2}		14.4	17.8	
			I_{CC1}, I_{CC2}		14.4	17.8	

6.10 Electrical Characteristics—3.3-V Supply

$V_{CC1} = V_{CC2} = 3.3\text{ V} \pm 10\%$ (over recommended operating conditions unless otherwise noted).

PARAMETER		TEST CONDITIONS	MIN	TYP	MAX	UNIT
V_{OH}	High-level output voltage	$I_{OH} = -2\text{ mA}$; See 图 7-1	$V_{CCO} - 0.2$			V
V_{OL}	Low-level output voltage	$I_{OL} = 2\text{ mA}$; See 图 7-1			0.2	V
$V_{IT+(IN)}$	Rising input switching threshold			$0.7 \times V_{CCI}^{(1)}$		V
$V_{IT-(IN)}$	Falling input switching threshold		$0.3 \times V_{CCI}$			V
$V_{I(HYS)}$	Input threshold voltage hysteresis		$0.1 \times V_{CCI}$			V
I_{IH}	High-level input current	$V_{IH} = V_{CCI}^{(1)}$ at INx			10	μA
I_{IL}	Low-level input current	$V_{IL} = 0\text{ V}$ at INx	-10			μA
CMTI	Common mode transient immunity	$V_I = V_{CC}$ or 0 V , $V_{CM} = 1200\text{ V}$; See 图 7-3	100	150		kV/us
C_i	Input Capacitance ⁽²⁾	$V_I = V_{CC}/2 + 0.4 \times \sin(2\pi ft)$, $f = 2\text{ MHz}$, $V_{CC} = 3.3\text{ V}$		2.8		pF

- (1) $V_{CCI} =$ Input-side V_{CC} ; $V_{CCO} =$ Output-side V_{CC}
 (2) Measured from input pin to same side ground.

6.11 Supply Current Characteristics—3.3-V Supply

$V_{CC1} = V_{CC2} = 3.3\text{ V} \pm 10\%$ (over recommended operating conditions unless otherwise noted).

PARAMETER	TEST CONDITIONS		SUPPLY CURRENT	MIN	TYP	MAX	UNIT
ISO6760							
Supply current - DC signal	$V_I = V_{CC1}$ (ISO6760); $V_I = 0\text{ V}$ (ISO6760 with F suffix)		I_{CC1}		2.2	2.8	mA
			I_{CC2}		3.1	5.1	
	$V_I = 0\text{ V}$ (ISO6760); $V_I = V_{CC1}$ (ISO6760 with F suffix)		I_{CC1}		8.3	10.9	
			I_{CC2}		3.4	5.6	
Supply current - AC signal	All channels switching with square wave clock input; $CL = 15\text{ pF}$	1 Mbps	I_{CC1}		5.3	6.9	
			I_{CC2}		3.5	5.7	
		10 Mbps	I_{CC1}		5.3	7	
			I_{CC2}		5.9	8.5	
		50 Mbps	I_{CC1}		5.9	7.6	
			I_{CC2}		16.6	20.9	
ISO6761							
Supply current - DC signal	$V_I = V_{CC1}$ (ISO6761); $V_I = 0\text{ V}$ (ISO6761 with F suffix)		I_{CC1}		2.4	3.5	mA
			I_{CC2}		3.6	5.8	
	$V_I = 0\text{ V}$ (ISO6761); $V_I = V_{CC1}$ (ISO6761 with F suffix)	I_{CC1}		7.5	10.3		
		I_{CC2}		4.9	7.5		
Supply current - AC signal	All channels switching with square wave clock input; $CL = 15\text{ pF}$	1 Mbps	I_{CC1}		5	7	
			I_{CC2}		4.5	6.9	
		10 Mbps	I_{CC1}		5.5	7.5	
			I_{CC2}		6.5	9.2	
		50 Mbps	I_{CC1}		7.7	10	
			I_{CC2}		15.5	19.6	
ISO6762							

$V_{CC1} = V_{CC2} = 3.3\text{ V} \pm 10\%$ (over recommended operating conditions unless otherwise noted).

PARAMETER	TEST CONDITIONS		SUPPLY CURRENT	MIN	TYP	MAX	UNIT
Supply current - DC signal	$V_I = V_{CC1}$ (ISO6762); $V_I = 0\text{ V}$ (ISO6762 with F suffix)		I_{CC1}		2.7	4.1	mA
			I_{CC2}		3.3	5.2	
	$V_I = 0\text{ V}$ (ISO6762); $V_I = V_{CC1}$ (ISO6762 with F suffix)		I_{CC1}		6.9	9.6	
			I_{CC2}		5.6	8.2	
Supply current - AC signal	All channels switching with square wave clock input; $C_L = 15\text{ pF}$	1 Mbps	I_{CC1}		4.9	6.9	
			I_{CC2}		4.6	6.9	
		10 Mbps	I_{CC1}		5.7	7.9	
			I_{CC2}		6.2	8.8	
		50 Mbps	I_{CC1}		9.6	12.4	
			I_{CC2}		13.5	17.1	
ISO6763							
Supply current - DC signal	$V_I = V_{CCI}$ (ISO6763); $V_I = 0\text{ V}$ (ISO6763 with F suffix)		I_{CC1}, I_{CC2}		3	4.6	mA
	$V_I = 0\text{ V}$ (ISO6763); $V_I = V_{CCI}$ (ISO6763 with F suffix)		I_{CC1}, I_{CC2}		6.2	8.9	
Supply current - AC signal	All channels switching with square wave clock input; $C_L = 15\text{ pF}$	1 Mbps	I_{CC1}, I_{CC2}		4.8	6.9	
			10 Mbps	I_{CC1}, I_{CC2}		6	
		50 Mbps		I_{CC1}, I_{CC2}		11.6	
			I_{CC1}, I_{CC2}				

6.12 Electrical Characteristics—2.5-V Supply

$V_{CC1} = V_{CC2} = 2.5\text{ V} \pm 10\%$ (over recommended operating conditions unless otherwise noted).

PARAMETER		TEST CONDITIONS	MIN	TYP	MAX	UNIT
V_{OH}	High-level output voltage	$I_{OH} = -1\text{ mA}$; See 图 7-1	$V_{CCO} - 0.1$			V
V_{OL}	Low-level output voltage	$I_{OL} = 1\text{ mA}$; See 图 7-1			0.1	V
$V_{IT+(IN)}$	Rising input switching threshold			$0.7 \times V_{CCI}^{(1)}$		V
$V_{IT-(IN)}$	Falling input switching threshold		$0.3 \times V_{CCI}$			V
$V_{I(HYS)}$	Input threshold voltage hysteresis		$0.1 \times V_{CCI}$			V
I_{IH}	High-level input current	$V_{IH} = V_{CCI}^{(1)}$ at INx			10	μA
I_{IL}	Low-level input current	$V_{IL} = 0\text{ V}$ at INx	-10			μA
CMTI	Common mode transient immunity	$V_I = V_{CC}$ or 0 V , $V_{CM} = 1200\text{ V}$; See 图 7-3	100	150		kV/us
C_i	Input Capacitance ⁽²⁾	$V_I = V_{CC}/2 + 0.4 \times \sin(2\pi ft)$, $f = 2\text{ MHz}$, $V_{CC} = 2.5\text{ V}$		2.8		pF

(1) $V_{CCI} =$ Input-side V_{CC} ; $V_{CCO} =$ Output-side V_{CC}

(2) Measured from input pin to same side ground.

6.13 Supply Current Characteristics—2.5-V Supply

$V_{CC1} = V_{CC2} = 2.5\text{ V} \pm 10\%$ (over recommended operating conditions unless otherwise noted).

PARAMETER	TEST CONDITIONS		SUPPLY CURRENT	MIN	TYP	MAX	UNIT
ISO6760							
Supply current - DC signal	$V_I = V_{CC1}$ (ISO6760); $V_I = 0\text{ V}$ (ISO6760 with F suffix)	I_{CC1}		2.2	2.8	mA	
		I_{CC2}		3.1	5.1		
	$V_I = 0\text{ V}$ (ISO6760); $V_I = V_{CC1}$ (ISO6760 with F suffix)	I_{CC1}		8.3	10.8		
		I_{CC2}		3.4	5.6		
Supply current - AC signal	All channels switching with square wave clock input; $CL = 15\text{ pF}$	1 Mbps	I_{CC1}		5.2		6.8
			I_{CC2}		3.5		5.6
		10 Mbps	I_{CC1}		5.3		6.9
			I_{CC2}		5.3		7.7
		50 Mbps	I_{CC1}		5.7	7.5	
			I_{CC2}		13.2	16.9	
ISO6761							
Supply current - DC signal	$V_I = V_{CC1}$ (ISO6761); $V_I = 0\text{ V}$ (ISO6761 with F suffix)	I_{CC1}		2.4	3.5	mA	
		I_{CC2}		3.6	5.7		
	$V_I = 0\text{ V}$ (ISO6761); $V_I = V_{CC1}$ (ISO6761 with F suffix)	I_{CC1}		7.5	10.3		
		I_{CC2}		4.9	7.5		
Supply current - AC signal	All channels switching with square wave clock input; $CL = 15\text{ pF}$	1 Mbps	I_{CC1}		5		6.9
			I_{CC2}		4.4		6.8
		10 Mbps	I_{CC1}		5.3		7.3
			I_{CC2}		5.9		8.5
		50 Mbps	I_{CC1}		7	9.3	
			I_{CC2}		12.7	16.3	
ISO6762							

$V_{CC1} = V_{CC2} = 2.5\text{ V} \pm 10\%$ (over recommended operating conditions unless otherwise noted).

PARAMETER	TEST CONDITIONS		SUPPLY CURRENT	MIN	TYP	MAX	UNIT
Supply current - DC signal	$V_I = V_{CC1}$ (ISO6762); $V_I = 0\text{ V}$ (ISO6762 with F suffix)		I_{CC1}		2.7	4	mA
			I_{CC2}		3.3	5.2	
	$V_I = 0\text{ V}$ (ISO6762); $V_I = V_{CC1}$ (ISO6762 with F suffix)		I_{CC1}		6.9	9.6	
			I_{CC2}		5.6	8.2	
Supply current - AC signal	All channels switching with square wave clock input; $C_L = 15\text{ pF}$	1 Mbps	I_{CC1}		4.9	6.9	
			I_{CC2}		4.6	6.8	
		10 Mbps	I_{CC1}		5.5	7.6	
			I_{CC2}		5.8	8.2	
		50 Mbps	I_{CC1}		8.4	11	
			I_{CC2}		11.2	14.5	
ISO6763							
Supply current - DC signal	$V_I = V_{CCI}$ (ISO6763); $V_I = 0\text{ V}$ (ISO6763 with F suffix)		I_{CC1}, I_{CC2}		3	4.6	mA
	$V_I = 0\text{ V}$ (ISO6763); $V_I = V_{CCI}$ (ISO6763 with F suffix)		I_{CC1}, I_{CC2}		6.2	8.9	
Supply current - AC signal	All channels switching with square wave clock input; $C_L = 15\text{ pF}$	1 Mbps	I_{CC1}, I_{CC2}		4.7	6.9	
		10 Mbps	I_{CC1}, I_{CC2}		5.6	7.9	
		50 Mbps	I_{CC1}, I_{CC2}		9.8	12.7	

Electrical Characteristics—1.8-V Supply

$V_{CC1} = V_{CC2} = 1.8\text{ V} \pm 10\%$ (over recommended operating conditions unless otherwise noted).

PARAMETER		TEST CONDITIONS	MIN	TYP	MAX	UNIT
V_{OH}	High-level output voltage	$I_{OH} = -1\text{ mA}$; See 图 7-1	$V_{CCO} - 0.1$			V
V_{OL}	Low-level output voltage	$I_{OL} = 1\text{ mA}$; See 图 7-1			0.1	V
$V_{IT+(IN)}$	Rising input switching threshold			$0.7 \times V_{CCI}^{(1)}$		V
$V_{IT-(IN)}$	Falling input switching threshold		$0.3 \times V_{CCI}$			V
$V_{I(HYS)}$	Input threshold voltage hysteresis		$0.1 \times V_{CCI}$			V
I_{IH}	High-level input current	$V_{IH} = V_{CCI}^{(1)}$ at INx			10	μA
I_{IL}	Low-level input current	$V_{IL} = 0\text{ V}$ at INx	-10			μA
CMTI	Common mode transient immunity	$V_I = V_{CC}$ or 0 V , $V_{CM} = 1200\text{ V}$; See 图 7-3	50	75		kV/us
C_i	Input Capacitance ⁽²⁾	$V_I = V_{CC}/2 + 0.4 \times \sin(2\pi ft)$, $f = 2\text{ MHz}$, $V_{CC} = 1.8\text{ V}$		2.8		pF

(1) $V_{CCI} =$ Input-side V_{CC} ; $V_{CCO} =$ Output-side V_{CC}

(2) Measured from input pin to same side ground.

6.14 Supply Current Characteristics—1.8-V Supply

$V_{CC1} = V_{CC2} = 1.8\text{ V} \pm 10\%$ (over recommended operating conditions unless otherwise noted).

PARAMETER	TEST CONDITIONS		SUPPLY CURRENT	MIN	TYP	MAX	UNIT
ISO6760							
Supply current - DC signal	$V_I = V_{CC1}$ (ISO6760); $V_I = 0\text{ V}$ (ISO6760 with F suffix)		I_{CC1}		1.5	2.1	mA
			I_{CC2}		3	5.1	
	$V_I = 0\text{ V}$ (ISO6760); $V_I = V_{CC1}$ (ISO6760 with F suffix)		I_{CC1}		7.3	10.3	
			I_{CC2}		3.3	5.6	
Supply current - AC signal	All channels switching with square wave clock input; $CL = 15\text{ pF}$	1 Mbps	I_{CC1}		4.4	6.2	
			I_{CC2}		3.3	5.5	
		10 Mbps	I_{CC1}		4.5	6.3	
			I_{CC2}		4.6	7	
		50 Mbps	I_{CC1}		4.8	6.7	
			I_{CC2}		10.1	13	
ISO6761							
Supply current - DC signal	$V_I = V_{CC1}$ (ISO6761); $V_I = 0\text{ V}$ (ISO6761 with F suffix)		I_{CC1}		1.8	2.9	mA
			I_{CC2}		3.4	5.7	
	$V_I = 0\text{ V}$ (ISO6761); $V_I = V_{CC1}$ (ISO6761 with F suffix)	I_{CC1}		6.7	9.8		
		I_{CC2}		4.6	7.4		
Supply current - AC signal	All channels switching with square wave clock input; $CL = 15\text{ pF}$	1 Mbps	I_{CC1}		4.3	6.4	
			I_{CC2}		4.1	6.7	
		10 Mbps	I_{CC1}		4.6	6.7	
			I_{CC2}		5.2	7.9	
		50 Mbps	I_{CC1}		5.8	8.1	
			I_{CC2}		9.9	13	
ISO6762							

$V_{CC1} = V_{CC2} = 1.8\text{ V} \pm 10\%$ (over recommended operating conditions unless otherwise noted).

PARAMETER	TEST CONDITIONS		SUPPLY CURRENT	MIN	TYP	MAX	UNIT
Supply current - DC signal	$V_I = V_{CC1}$ (ISO6762); $V_I = 0\text{ V}$ (ISO6762 with F suffix)		I_{CC1}		2.2	3.6	mA
			I_{CC2}		3	5	
	$V_I = 0\text{ V}$ (ISO6762); $V_I = V_{CC1}$ (ISO6762 with F suffix)		I_{CC1}		6.2	9.2	
			I_{CC2}		5.1	8	
Supply current - AC signal	All channels switching with square wave clock input; $C_L = 15\text{ pF}$	1 Mbps	I_{CC1}		4.3	6.5	
			I_{CC2}		4.2	6.6	
		10 Mbps	I_{CC1}		4.7	7	
			I_{CC2}		5	7.6	
		50 Mbps	I_{CC1}		6.8	9.3	
			I_{CC2}		8.9	11.8	
ISO6763							
Supply current - DC signal	$V_I = V_{CCI}$ (ISO6763); $V_I = 0\text{ V}$ (ISO6763 with F suffix)		I_{CC1}, I_{CC2}		2.6	4.3	mA
	$V_I = 0\text{ V}$ (ISO6763); $V_I = V_{CCI}$ (ISO6763 with F suffix)		I_{CC1}, I_{CC2}		5.7	8.6	
Supply current - AC signal	All channels switching with square wave clock input; $C_L = 15\text{ pF}$	1 Mbps	I_{CC1}, I_{CC2}		4.2	6.5	
			I_{CC1}, I_{CC2}		4.9	7.3	
		50 Mbps	I_{CC1}, I_{CC2}		7.9	10.5	
			I_{CC1}, I_{CC2}				

6.15 Switching Characteristics—5-V Supply

$V_{CC1} = V_{CC2} = 5\text{ V} \pm 10\%$ (over recommended operating conditions unless otherwise noted)

PARAMETER		TEST CONDITIONS		MIN	TYP	MAX	UNIT
ISO676x							
t_{PLH}, t_{PHL}	Propagation delay time	Propagation delay time	See 图 7-1		11	18	ns
PWD	Pulse width distortion ⁽¹⁾ $ t_{PHL} - t_{PLH} $	Pulse width distortion ⁽¹⁾ $ t_{PHL} - t_{PLH} $					7
$t_{sk(o)}$	Channel-to-channel output skew time ⁽²⁾	Channel-to-channel output skew time ⁽²⁾	Same-direction channels			6	ns
$t_{sk(pp)}$	Part-to-part skew time ⁽³⁾	Part-to-part skew time ⁽³⁾				6	ns
t_r	Output signal rise time	Output signal rise time	See 图 7-1			4.5	ns
t_f	Output signal fall time	Output signal fall time				4.5	ns
t_{PU}	Time from UVLO to valid output data	Time from UVLO to valid output data				300	us
t_{DO}	Default output delay time from input power loss	Default output delay time from input power loss	Measured from the time VCC goes below 1.2V. See 图 7-2		0.1	0.3	us
t_{ie}	Time interval error	Time interval error	$2^{16} - 1$ PRBS data at 50 Mbps		1		ns

(1) Also known as pulse skew.

(2) $t_{sk(o)}$ is the skew between outputs of a single device with all driving inputs connected together and the outputs switching in the same direction while driving identical loads.

(3) $t_{sk(pp)}$ is the magnitude of the difference in propagation delay times between any terminals of different devices switching in the same direction while operating at identical supply voltages, temperature, input signals and loads.

6.16 Switching Characteristics—3.3-V Supply

$V_{CC1} = V_{CC2} = 3.3\text{ V} \pm 10\%$ (over recommended operating conditions unless otherwise noted)

PARAMETER		TEST CONDITIONS		MIN	TYP	MAX	UNIT
ISO676x							
t_{PLH}, t_{PHL}	Propagation delay time	Propagation delay time	See 图 7-1		11	18	ns
PWD	Pulse width distortion ⁽¹⁾ $ t_{PHL} - t_{PLH} $	Pulse width distortion ⁽¹⁾ $ t_{PHL} - t_{PLH} $					7
$t_{sk(o)}$	Channel-to-channel output skew time ⁽²⁾	Channel-to-channel output skew time ⁽²⁾	Same-direction channels			6	ns
$t_{sk(pp)}$	Part-to-part skew time ⁽³⁾	Part-to-part skew time ⁽³⁾				7	ns
t_r	Output signal rise time	Output signal rise time	See 图 7-1			3.2	ns
t_f	Output signal fall time	Output signal fall time				3.2	ns
t_{PU}	Time from UVLO to valid output data	Time from UVLO to valid output data				300	us
t_{DO}	Default output delay time from input power loss	Default output delay time from input power loss	Measured from the time VCC goes below 1.2V. See 图 7-2		0.1	0.3	us
t_{ie}	Time interval error	Time interval error	$2^{16} - 1$ PRBS data at 50 Mbps		1		ns

(1) Also known as pulse skew.

(2) $t_{sk(o)}$ is the skew between outputs of a single device with all driving inputs connected together and the outputs switching in the same direction while driving identical loads.

(3) $t_{sk(pp)}$ is the magnitude of the difference in propagation delay times between any terminals of different devices switching in the same direction while operating at identical supply voltages, temperature, input signals and loads.

6.17 Switching Characteristics—2.5-V Supply

$V_{CC1} = V_{CC2} = 2.5\text{ V} \pm 10\%$ (over recommended operating conditions unless otherwise noted)

PARAMETER		TEST CONDITIONS		MIN	TYP	MAX	UNIT
ISO676x							
t_{PLH}, t_{PHL}	Propagation delay time	Propagation delay time	See 图 7-1	12	20.5		ns
PWD	Pulse width distortion ⁽¹⁾ $ t_{PHL} - t_{PLH} $	Pulse width distortion ⁽¹⁾ $ t_{PHL} - t_{PLH} $				7.1	
$t_{sk(o)}$	Channel-to-channel output skew time ⁽²⁾	Channel-to-channel output skew time ⁽²⁾	Same-direction channels			6	ns
$t_{sk(pp)}$	Part-to-part skew time ⁽³⁾	Part-to-part skew time ⁽³⁾				7	ns
t_r	Output signal rise time	Output signal rise time	See 图 7-1			4	ns
t_f	Output signal fall time	Output signal fall time				4	ns
t_{PU}	Time from UVLO to valid output data	Time from UVLO to valid output data				300	us
t_{DO}	Default output delay time from input power loss	Default output delay time from input power loss	Measured from the time VCC goes below 1.2V. See 图 7-2		0.1	0.3	us
t_{ie}	Time interval error	Time interval error	$2^{16} - 1$ PRBS data at 50 Mbps		1		ns

(1) Also known as pulse skew.

(2) $t_{sk(o)}$ is the skew between outputs of a single device with all driving inputs connected together and the outputs switching in the same direction while driving identical loads.

(3) $t_{sk(pp)}$ is the magnitude of the difference in propagation delay times between any terminals of different devices switching in the same direction while operating at identical supply voltages, temperature, input signals and loads.

6.18 Switching Characteristics—1.8-V Supply

$V_{CC1} = V_{CC2} = 1.8\text{ V} \pm 5\%$ (over recommended operating conditions unless otherwise noted)

PARAMETER		TEST CONDITIONS		MIN	TYP	MAX	UNIT
ISO676x							
t_{PLH}, t_{PHL}	Propagation delay time	Propagation delay time	See 图 7-1		15	24	ns
PWD	Pulse width distortion $ t_{PHL} - t_{PLH} $	Pulse width distortion $ t_{PHL} - t_{PLH} $					8.2
$t_{sk(o)}$	Channel-to-channel output skew time ⁽¹⁾	Channel-to-channel output skew time ⁽¹⁾	Same-direction channels			6	ns
$t_{sk(pp)}$	Part-to-part skew time ⁽²⁾	Part-to-part skew time ⁽²⁾				8.8	ns
t_r	Output signal rise time	Output signal rise time	See 图 7-1			4.7	ns
t_f	Output signal fall time	Output signal fall time				4.7	ns
t_{PU}	Time from UVLO to valid output data	Time from UVLO to valid output data				300	us
t_{DO}	Default output delay time from input power loss	Default output delay time from input power loss	Measured from the time VCC goes below 1.2V. See 图 7-2		0.1	0.3	us
t_{ie}	Time interval error	Time interval error	$2^{16} - 1$ PRBS data at 50 Mbps		1		ns

- (1) $t_{sk(o)}$ is the skew between outputs of a single device with all driving inputs connected together and the outputs switching in the same direction while driving identical loads.
- (2) $t_{sk(pp)}$ is the magnitude of the difference in propagation delay times between any terminals of different devices switching in the same direction while operating at identical supply voltages, temperature, input signals and loads.

6.19 Insulation Characteristics Curves

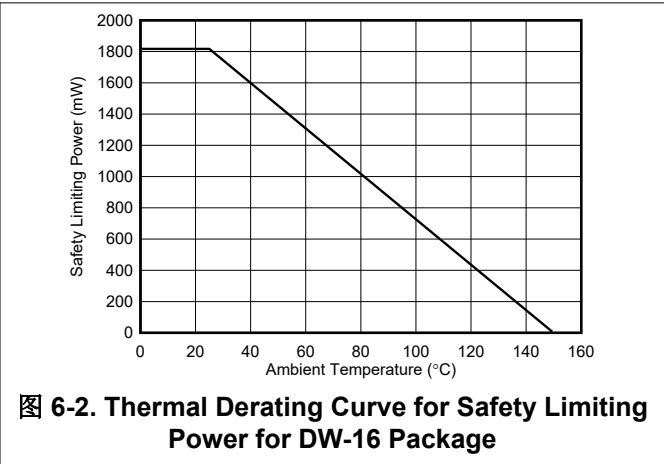
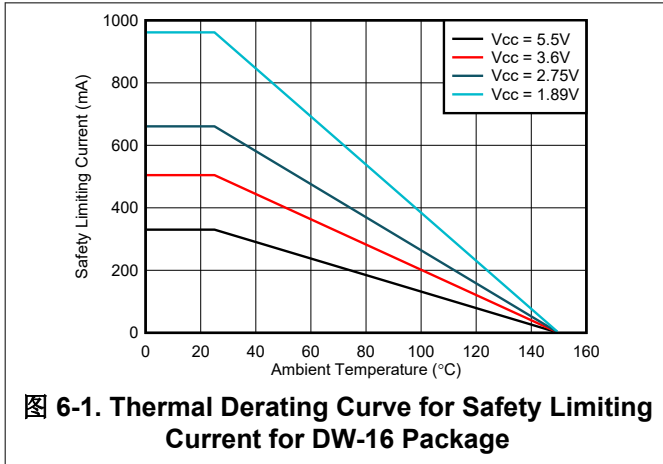

6.20 Typical Characteristics



图 6-3. ISO6760-Q1 Supply Current vs Data Rate (With 15-pF Load)



图 6-4. ISO6760-Q1 Supply Current vs Data Rate (With No Load)

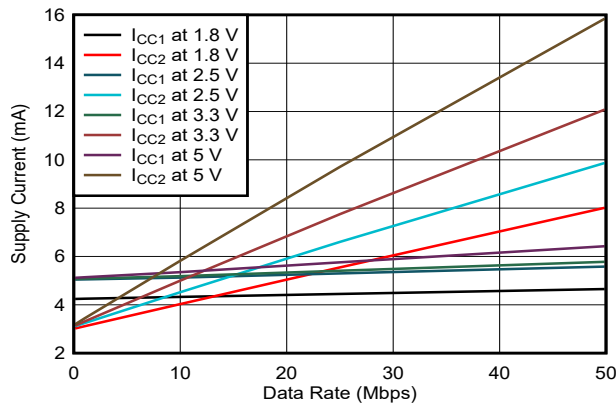

图 6-5. ISO6761-Q1 Supply Current vs Data Rate (With 15-pF Load)

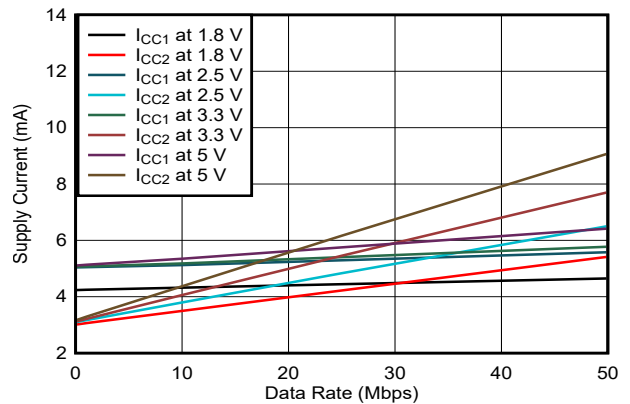

图 6-6. ISO6761-Q1 Supply Current vs Data Rate (With No Load)

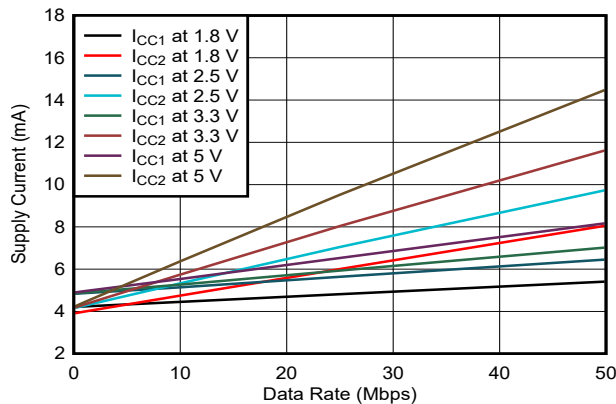

图 6-7. ISO6762-Q1 Supply Current vs Data Rate (With 15-pF Load)

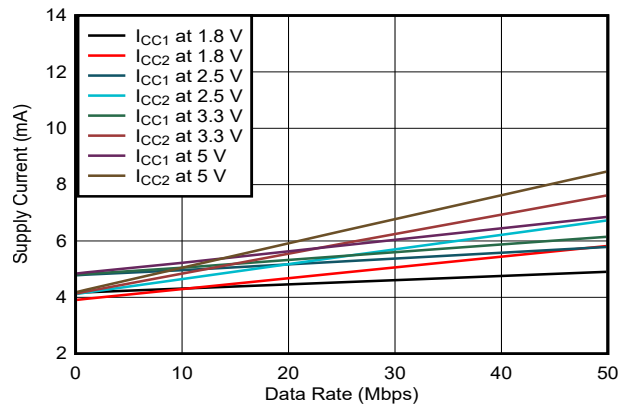

图 6-8. ISO6762-Q1 Supply Current vs Data Rate (With No Load)

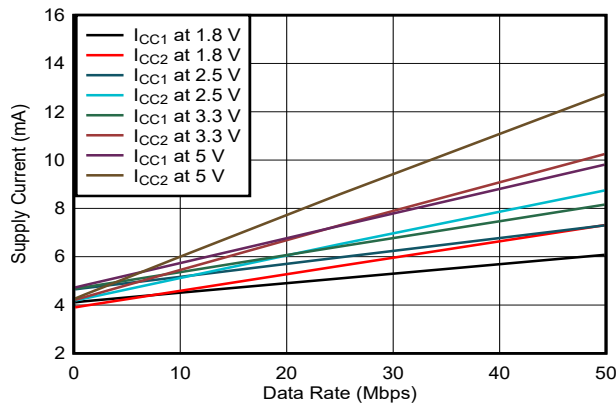

图 6-9. ISO6763-Q1 Supply Current vs Data Rate (With 15-pF Load)

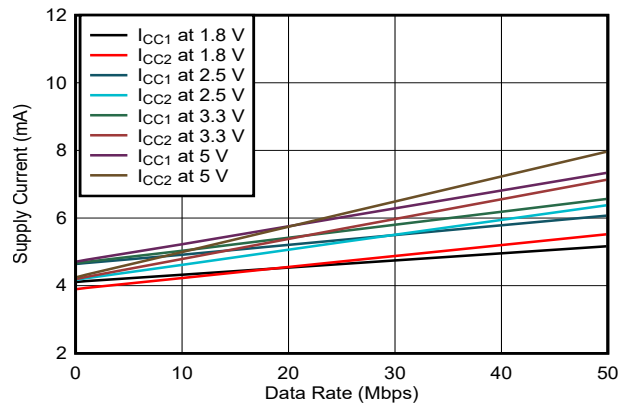

图 6-10. ISO6763-Q1 Supply Current vs Data Rate (With No Load)

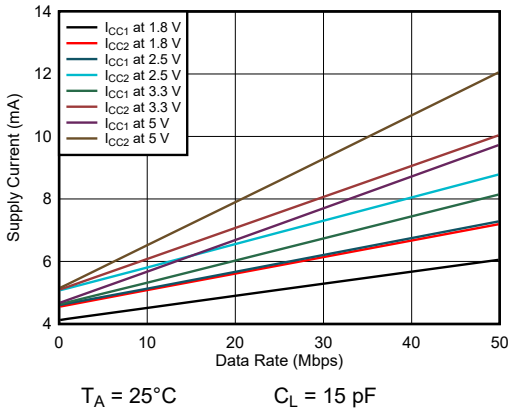

图 6-11. High-Level Output Voltage vs High-level Output Current

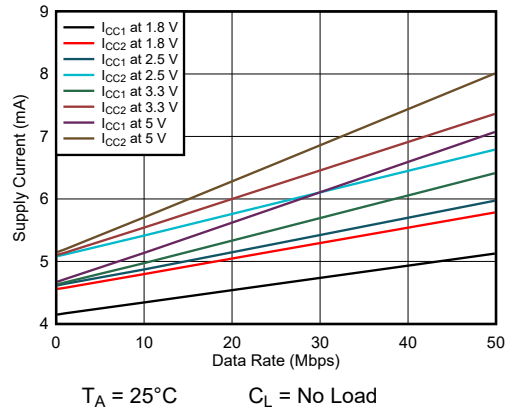

图 6-12. Propagation Delay Time vs Free-Air Temperature

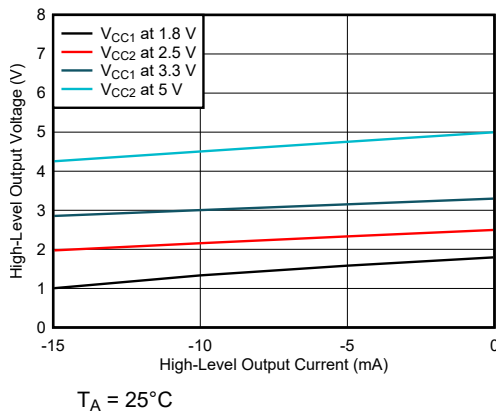

图 6-13. Power Supply Undervoltage Threshold vs Free-Air Temperature

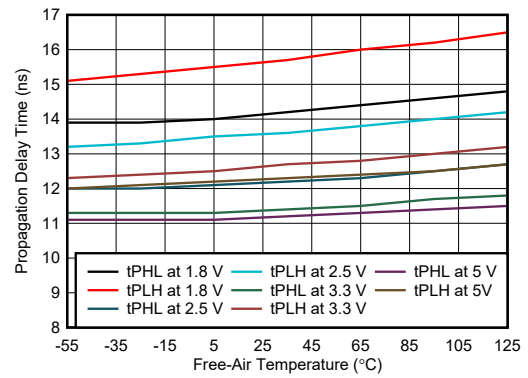

图 6-14. Low-Level Output Voltage vs Low-Level Output Current

7 Parameter Measurement Information

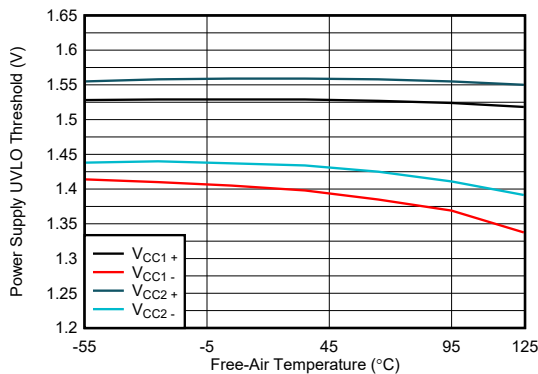

- A. The input pulse is supplied by a generator having the following characteristics: PRR \leq 50 kHz, 50% duty cycle, $t_r \leq$ 3 ns, $t_f \leq$ 3ns, $Z_0 = 50 \Omega$. At the input, 50Ω resistor is required to terminate Input Generator signal. It is not needed in actual application.
- B. $C_L = 15$ pF and includes instrumentation and fixture capacitance within $\pm 20\%$.

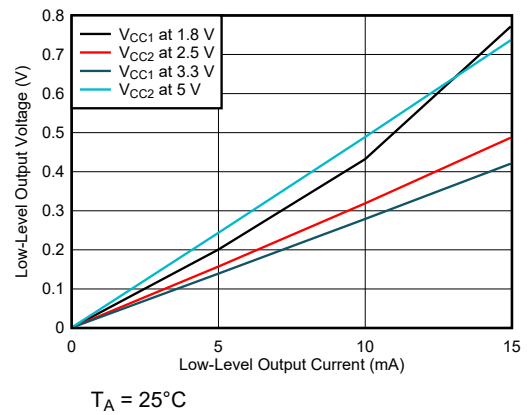
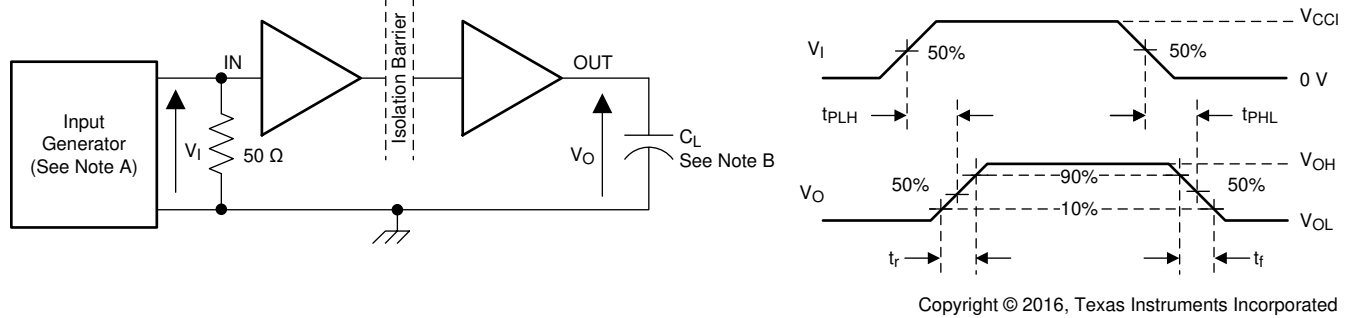
图 7-1. Switching Characteristics Test Circuit and Voltage Waveforms

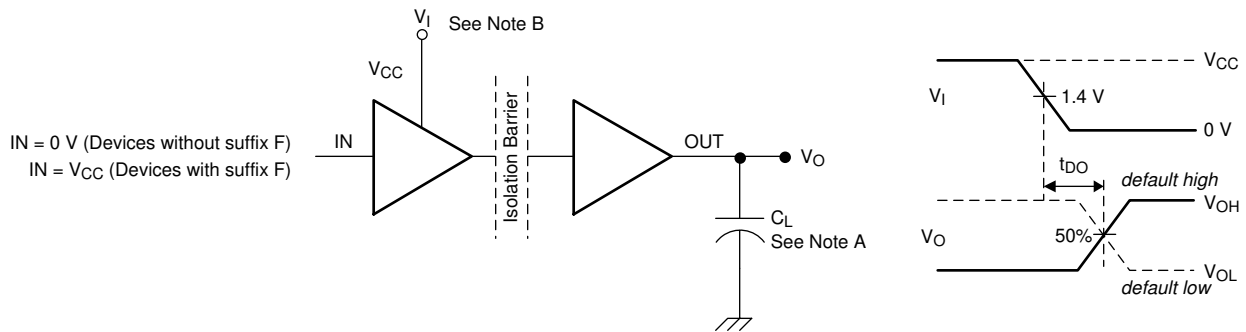

- A. $C_L = 15$ pF and includes instrumentation and fixture capacitance within $\pm 20\%$.
- B. Power Supply Ramp Rate = 10 mV/ns

图 7-2. Default Output Delay Time Test Circuit and Voltage Waveforms

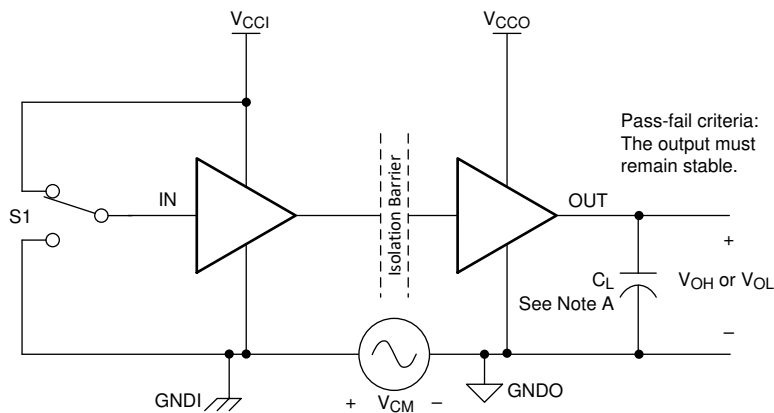

- A. $C_L = 15$ pF and includes instrumentation and fixture capacitance within $\pm 20\%$.
- B. For optimized CMTI performance, a $0.1 \mu F + 1 \mu F$ decoupling capacitor should be placed close to V_{CC1} and V_{CC2} . Please see 节 11.2 for capacitor placement details. A recommended $0.1 \mu F$ capacitor is LLL185R71A104MA11L (CAP CER 0.1UF 10V X7R 0306 - LW Reversed Low ESL Chip Ceramic Capacitors) or equivalent.

图 7-3. Common-Mode Transient Immunity Test Circuit

8 Detailed Description

8.1 Overview

The ISO676x-Q1 family of devices have an ON-OFF keying (OOK) modulation scheme to transmit the digital data across a silicon dioxide based isolation barrier. The transmitter sends a high frequency carrier across the barrier to represent one digital state and sends no signal to represent the other digital state. The receiver demodulates the signal after advanced signal conditioning and produces the output through a buffer stage. If the ENx pin is low then the output goes to high impedance. The ISO676x-Q1 devices also incorporate advanced circuit techniques to maximize the CMTI performance and minimize the radiated emissions due to the high frequency carrier and IO buffer switching. The conceptual block diagram of a digital capacitive isolator, [图 8-1](#), shows a functional block diagram of a typical channel.

8.2 Functional Block Diagram

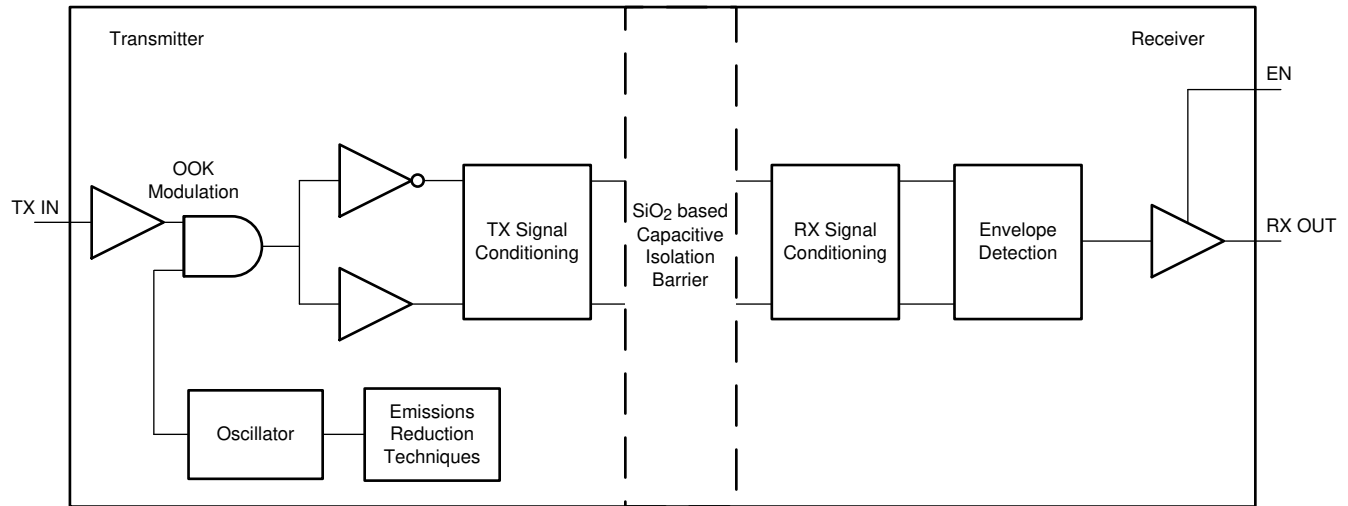

Copyright © 2016, Texas Instruments Incorporated

图 8-1. Conceptual Block Diagram of a Digital Capacitive Isolator

[图 8-2](#) shows a conceptual detail of how the ON-OFF keying scheme works.



图 8-2. On-Off Keying (OOK) Based Modulation Scheme

8.3 Feature Description

表 8-1 provides an overview of the device features.

表 8-1. Device Features

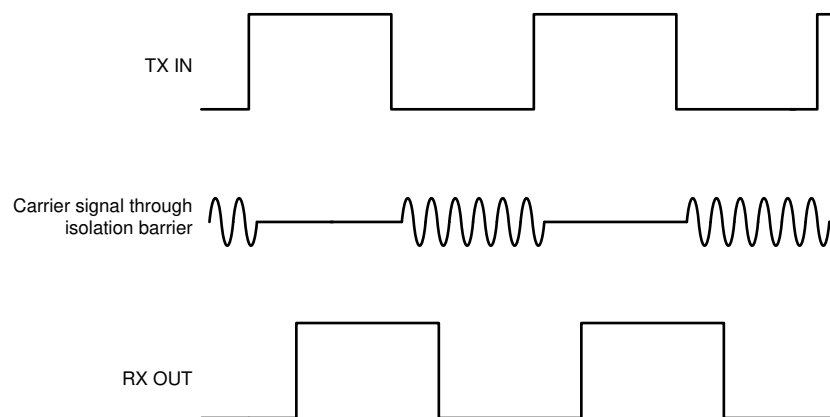
PART NUMBER	CHANNEL DIRECTION	MAXIMUM DATA RATE	DEFAULT OUTPUT	PACKAGE	RATED ISOLATION ⁽¹⁾
ISO6760-Q1	6 Forward, 0 Reverse	50 Mbps	High	DW-16	5000 V _{RMS} / 7071 V _{PK}
ISO6760F-Q1	6 Forward, 0 Reverse	50 Mbps	Low	DW-16	5000 V _{RMS} / 7071 V _{PK}
ISO6761-Q1	5 Forward, 1 Reverse	50 Mbps	High	DW-16	5000 V _{RMS} / 7071 V _{PK}
ISO6761F-Q1	5 Forward, 1 Reverse	50 Mbps	Low	DW-16	5000 V _{RMS} / 7071 V _{PK}
ISO6762-Q1	4 Forward, 2 Reverse	50 Mbps	High	DW-16	5000 V _{RMS} / 7071 V _{PK}
ISO6762F-Q1	4 Forward, 2 Reverse	50 Mbps	Low	DW-16	5000 V _{RMS} / 7071 V _{PK}
ISO6763-Q1	3 Forward, 3 Reverse	50 Mbps	High	DW-16	5000 V _{RMS} / 7071 V _{PK}
ISO6763F-Q1	3 Forward, 3 Reverse	50 Mbps	Low	DW-16	5000 V _{RMS} / 7071 V _{PK}

(1) See for detailed isolation ratings.

8.3.1 Electromagnetic Compatibility (EMC) Considerations

Many applications in harsh industrial environment are sensitive to disturbances such as electrostatic discharge (ESD), electrical fast transient (EFT), surge and electromagnetic emissions. These electromagnetic disturbances are regulated by international standards such as IEC 61000-4-x and CISPR 25. Although system-level performance and reliability depends, to a large extent, on the application board design and layout, the ISO676x-Q1 family of devices incorporates many chip-level design improvements for overall system robustness. Some of these improvements include:

- Robust ESD protection cells for input and output signal pins and inter-chip bond pads.
- Low-resistance connectivity of ESD cells to supply and ground pins.
- Enhanced performance of high voltage isolation capacitor for better tolerance of ESD, EFT and surge events.
- Bigger on-chip decoupling capacitors to bypass undesirable high energy signals through a low impedance path.
- PMOS and NMOS devices isolated from each other by using guard rings to avoid triggering of parasitic SCRs.
- Reduced common mode currents across the isolation barrier by ensuring purely differential internal operation.

8.4 Device Functional Modes

表 8-2 lists the functional modes for the ISO676x-Q1 devices.

表 8-2. Function Table

V_{CC1} ⁽¹⁾	V_{CC0}	INPUT (INx) ⁽³⁾	OUTPUT (OUTx)	COMMENTS
PU	PU	H	H	Normal Operation: A channel output assumes the logic state of its input.
		L	L	
		Open	Default	Default mode: When INx is open, the corresponding channel output goes to its default logic state. Default is <i>High</i> for ISO676x-Q1 and <i>Low</i> for ISO676x-Q1 with F suffix.
PD	PU	X	Default	Default mode: When V_{CC1} is unpowered, a channel output assumes the logic state based on the selected default option. Default is <i>High</i> for ISO676x-Q1 and <i>Low</i> for ISO676x-Q1 with F suffix. When V_{CC1} transitions from unpowered to powered-up, a channel output assumes the logic state of the input. When V_{CC1} transitions from powered-up to unpowered, channel output assumes the selected default state.
X	PD	X	Undetermined	When V_{CC0} is unpowered, a channel output is undetermined ⁽²⁾ . When V_{CC0} transitions from unpowered to powered-up, a channel output assumes the logic state of the input.

(1) V_{CC1} = Input-side V_{CC} ; V_{CC0} = Output-side V_{CC} ; PU = Powered up ($V_{CC} \geq 1.71$ V); PD = Powered down ($V_{CC} \leq 1.05$ V); X = Irrelevant; H = High level; L = Low level ; Z = High Impedance

(2) The outputs are in undetermined state when 1.05 V < V_{CC1} , V_{CC0} < 1.71 V and 1.89 V < V_{CC1} , V_{CC0} < 2.25 V

(3) A strongly driven input signal can weakly power the floating V_{CC} through an internal protection diode and cause undetermined output

8.4.1 Device I/O Schematics



图 8-3. Device I/O Schematics

9 Application and Implementation

备注

Information in the following applications sections is not part of the TI component specification, and TI does not warrant its accuracy or completeness. TI's customers are responsible for determining suitability of components for their purposes. Customers should validate and test their design implementation to confirm system functionality.

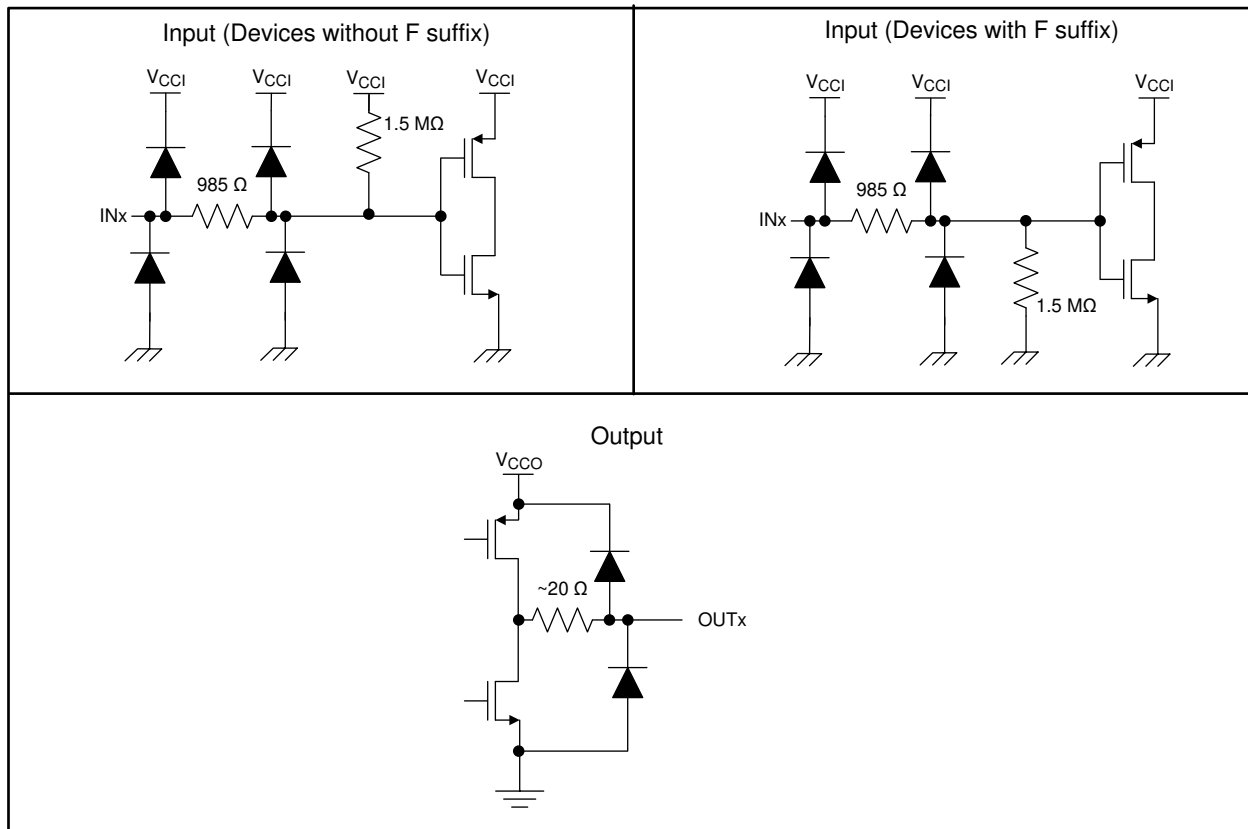
9.1 Application Information

The ISO676x-Q1 devices are high-performance, six-channel digital isolators. The ISO676x-Q1 devices use single-ended CMOS-logic switching technology. The supply voltage range is from 1.71 V to 5.5 V for both supplies, V_{CC1} and V_{CC2} . Since an isolation barrier separates the two sides, each side can be sourced independently with any voltage within recommended operating conditions. As an example, it is possible to supply ISO676x-Q1 V_{CC1} with 3.3 V (which is within 1.71 V to 5.5 V) and V_{CC2} with 5V (which is also within 1.71 V to 5.5 V). You can use the digital isolator as a logic-level translator in addition to providing isolation. When designing with digital isolators, keep in mind that because of the single-ended design structure, digital isolators do not conform to any specific interface standard and are only intended for isolating single-ended CMOS or TTL digital signal lines. The isolator is typically placed between the data controller (that is, MCU or FPGA), and a data converter or a line transceiver, regardless of the interface type or standard.

9.2 Typical Application

Figure 9-1 shows the isolated serial-peripheral interface (SPI) and controller-area network (CAN) interface implementation.

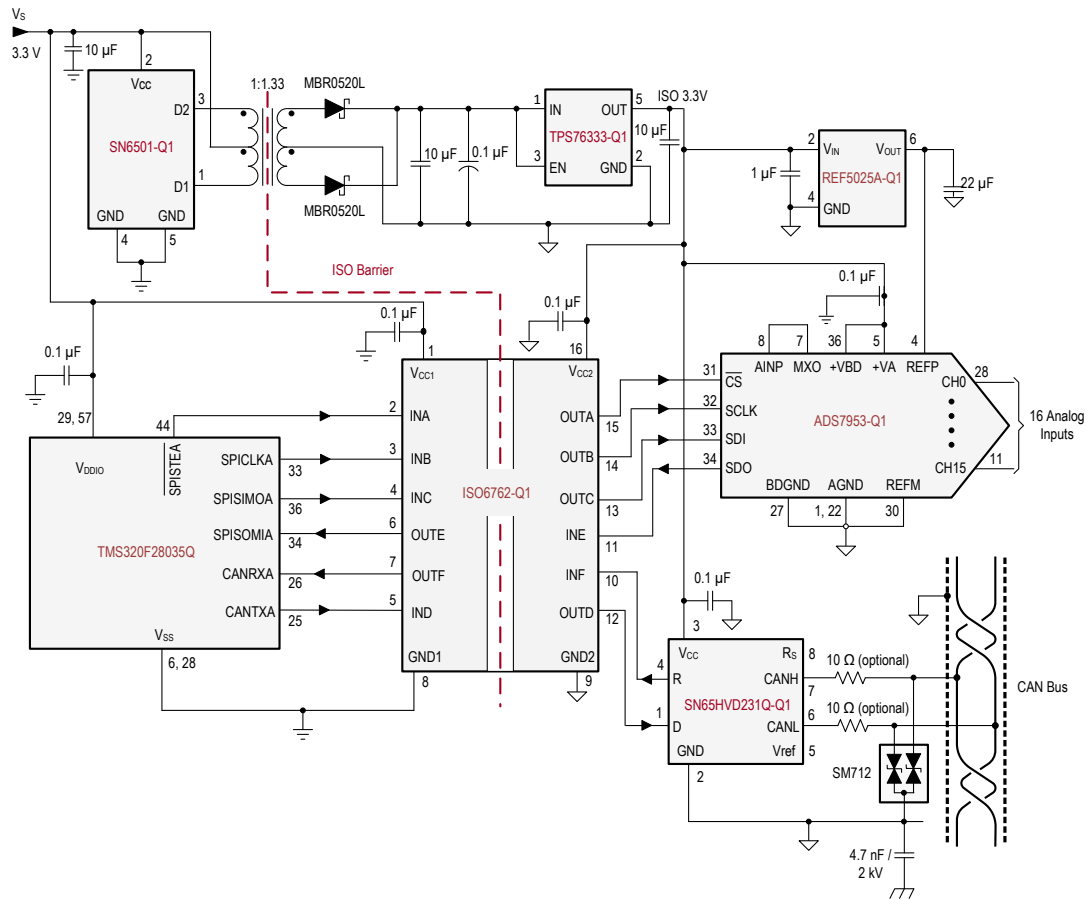

Figure 9-1. Isolated SPI and CAN Interface

9.2.1 Design Requirements

To design with these devices, use the parameters listed in 表 9-1.

表 9-1. Design Parameters

PARAMETER	VALUE
Supply voltage, V_{CC1} and V_{CC2}	1.71 V to 1.89 V and 2.25 V to 5.5 V
Decoupling capacitor between V_{CC1} and GND1	0.1 μ F
Decoupling capacitor from V_{CC2} and GND2	0.1 μ F

9.2.2 Detailed Design Procedure

Unlike optocouplers, which require external components to improve performance, provide bias, or limit current, the ISO676x-Q1 family of devices only require two external bypass capacitors to operate.



图 9-2. Typical ISO676x-Q1 Circuit Hook-up

9.2.3 Application Curve

The following typical eye diagrams of the ISO676x-Q1 family of devices indicates low jitter and wide open eye at the maximum data rate of 50 Mbps.

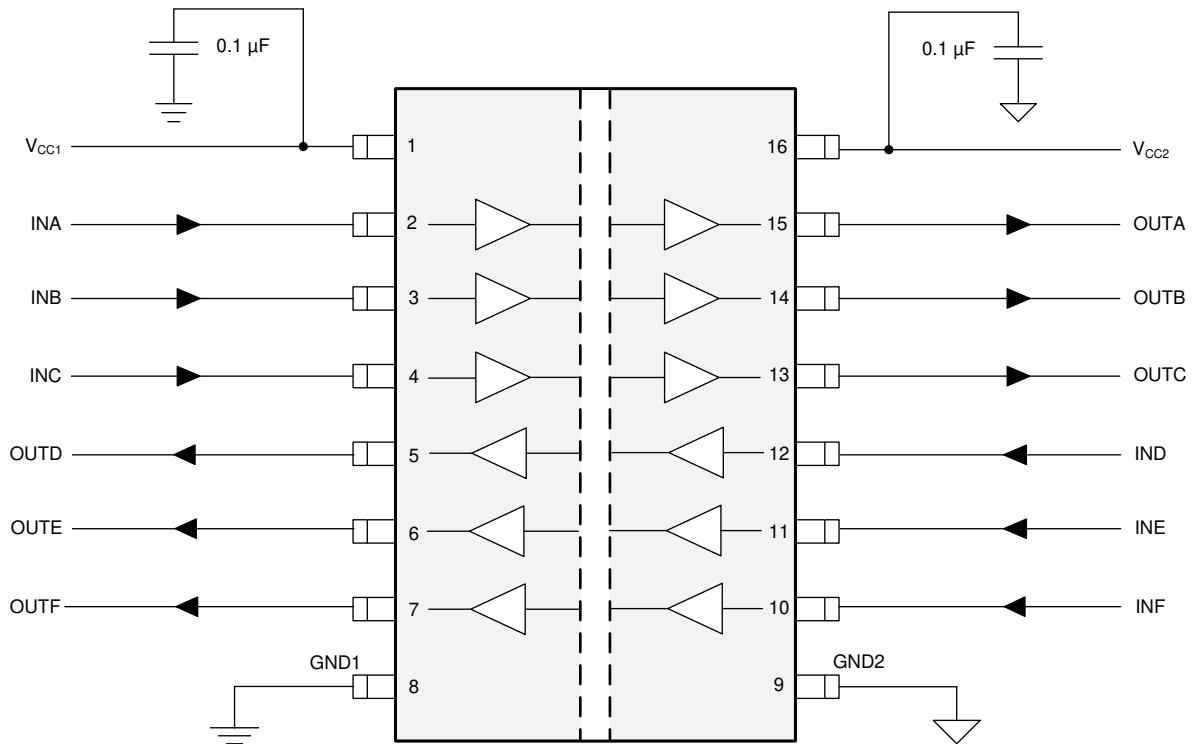

图 9-3. Eye Diagram at 50 Mbps PRBS $2^{16} - 1$, 5 V and 25°C



图 9-4. Eye Diagram at 50 Mbps PRBS $2^{16} - 1$, 3.3 V and 25°C

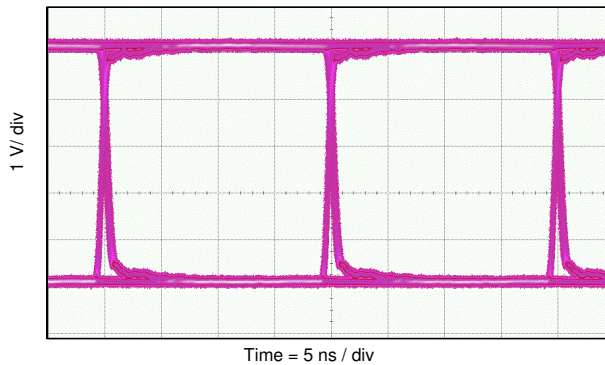

图 9-5. Eye Diagram at 50 Mbps PRBS $2^{16} - 1$, 2.5 V and 25°C

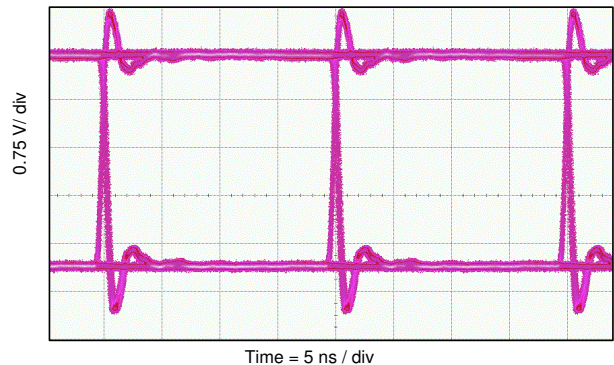

图 9-6. Eye Diagram at 50 Mbps PRBS $2^{16} - 1$, 1.8 V and 25°C

9.2.3.1 Insulation Lifetime

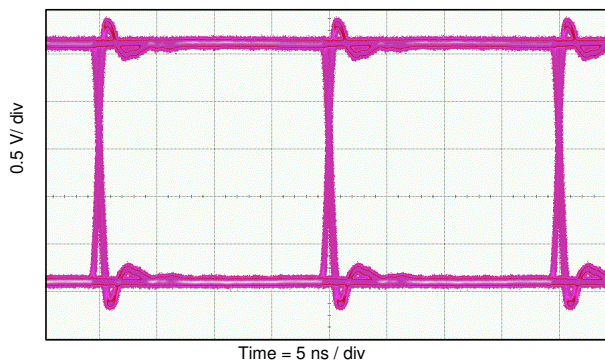
Insulation lifetime projection data is collected by using industry-standard Time Dependent Dielectric Breakdown (TDDB) test method. In this test, all pins on each side of the barrier are tied together creating a two-terminal device and high voltage applied between the two sides; See 图 9-7 for TDDB test setup. The insulation breakdown data is collected at various high voltages switching at 60 Hz over temperature. For reinforced insulation, VDE standard requires the use of TDDB projection line with failure rate of less than 1 part per million (ppm). Even though the expected minimum insulation lifetime is 20 years at the specified working isolation voltage, VDE reinforced certification requires additional safety margin of 20% for working voltage and 87.5% for lifetime which translates into minimum required insulation lifetime of 37.5 years at a working voltage that's 20% higher than the specified value.

图 9-8 shows the intrinsic capability of the isolation barrier to withstand high voltage stress over its lifetime. Based on the TDDB data, the intrinsic capability of the insulation is 1500 V_{RMS} with a lifetime of 220 years. Other factors, such as package size, pollution degree, material group, etc. can further limit the working voltage of the component. The working voltage of DW-16 package is specified upto 1500 V_{RMS}. At the lower working voltages, the corresponding insulation lifetime is much longer than 220 years.

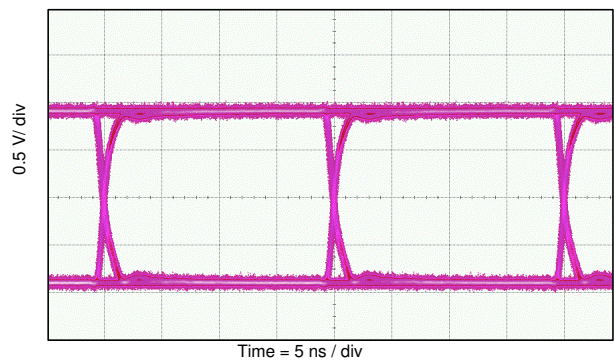

图 9-7. Test Setup for Insulation Lifetime Measurement



图 9-8. Insulation Lifetime Projection Data

10 Power Supply Recommendations

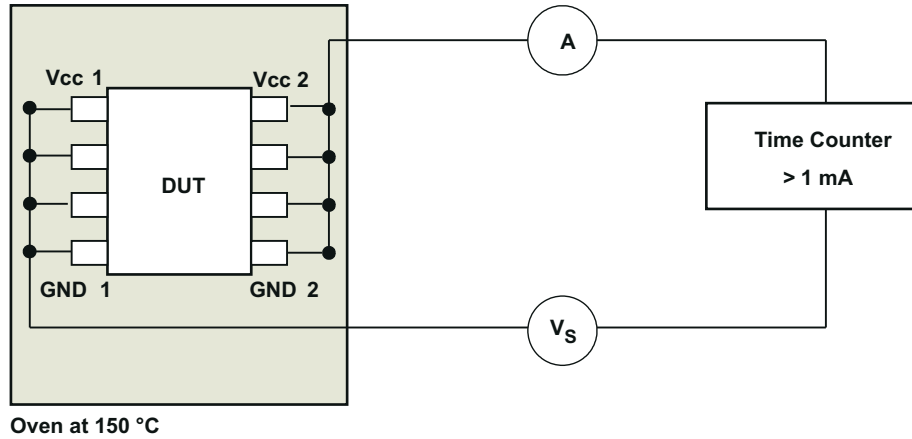
To help ensure reliable operation at data rates and supply voltages, a 0.1- μ F bypass capacitor is recommended at the input and output supply pins (V_{CC1} and V_{CC2}). The capacitors should be placed as close to the supply pins as possible. If only a single primary-side power supply is available in an application, isolated power can be generated for the secondary-side with the help of a transformer driver. For automotive applications, please use [SN6501-Q1](#) or [SN6505B-Q1](#). For such applications, detailed power supply design and transformer selection recommendations are available in [SN6501-Q1 Transformer Driver for Isolated Power Supplies](#) or [SN6505B-Q1 Automotive, low-noise, 1-A, 420-kHz transformer driver with soft start for isolated power supplies](#).

11 Layout

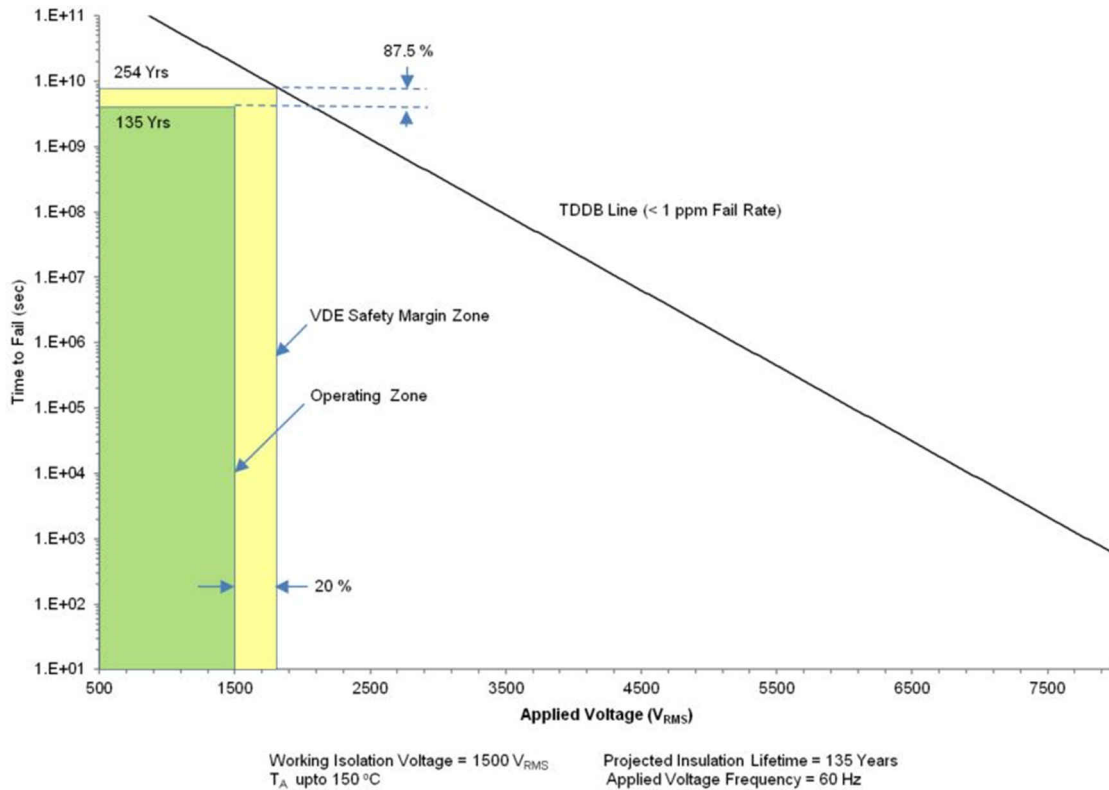
11.1 Layout Guidelines

A minimum of two layers is required to accomplish a low EMI PCB design. To further improve EMI, a four layer board can be used (see [Figure 11-2](#)). Layer stacking for a four layer board should be in the following order (top-to-bottom): high-speed signal layer, ground plane, power plane and low-frequency signal layer.

- Routing the high-speed traces on the top layer avoids the use of vias (and the introduction of their inductances) and allows for clean interconnects between the isolator and the transmitter and receiver circuits of the data link.
- Placing a solid ground plane next to the high-speed signal layer establishes controlled impedance for transmission line interconnects and provides an excellent low-inductance path for the return current flow.
- Placing the power plane next to the ground plane creates additional high-frequency bypass capacitance of approximately 100 pF/inch².
- Routing the slower speed control signals on the bottom layer allows for greater flexibility as these signal links usually have margin to tolerate discontinuities such as vias.

If an additional supply voltage plane or signal layer is needed, add a second power or ground plane system to the stack to keep it symmetrical. This makes the stack mechanically stable and prevents it from warping. Also the power and ground plane of each power system can be placed closer together, thus increasing the high-frequency bypass capacitance significantly.

For detailed layout recommendations, refer to the [Digital Isolator Design Guide](#).

11.1.1 PCB Material

For digital circuit boards operating below 150 Mbps, (or rise and fall times higher than 1 ns), and trace lengths of up to 10 inches, use standard FR-4 UL94V-0 printed circuit boards. This PCB is preferred over cheaper alternatives due to its lower dielectric losses at high frequencies, less moisture absorption, greater strength and stiffness, and self-extinguishing flammability-characteristics.

11.2 Layout Example



图 11-1. Layout Example



图 11-2. Four Layer Board Layout Example

12 Device and Documentation Support

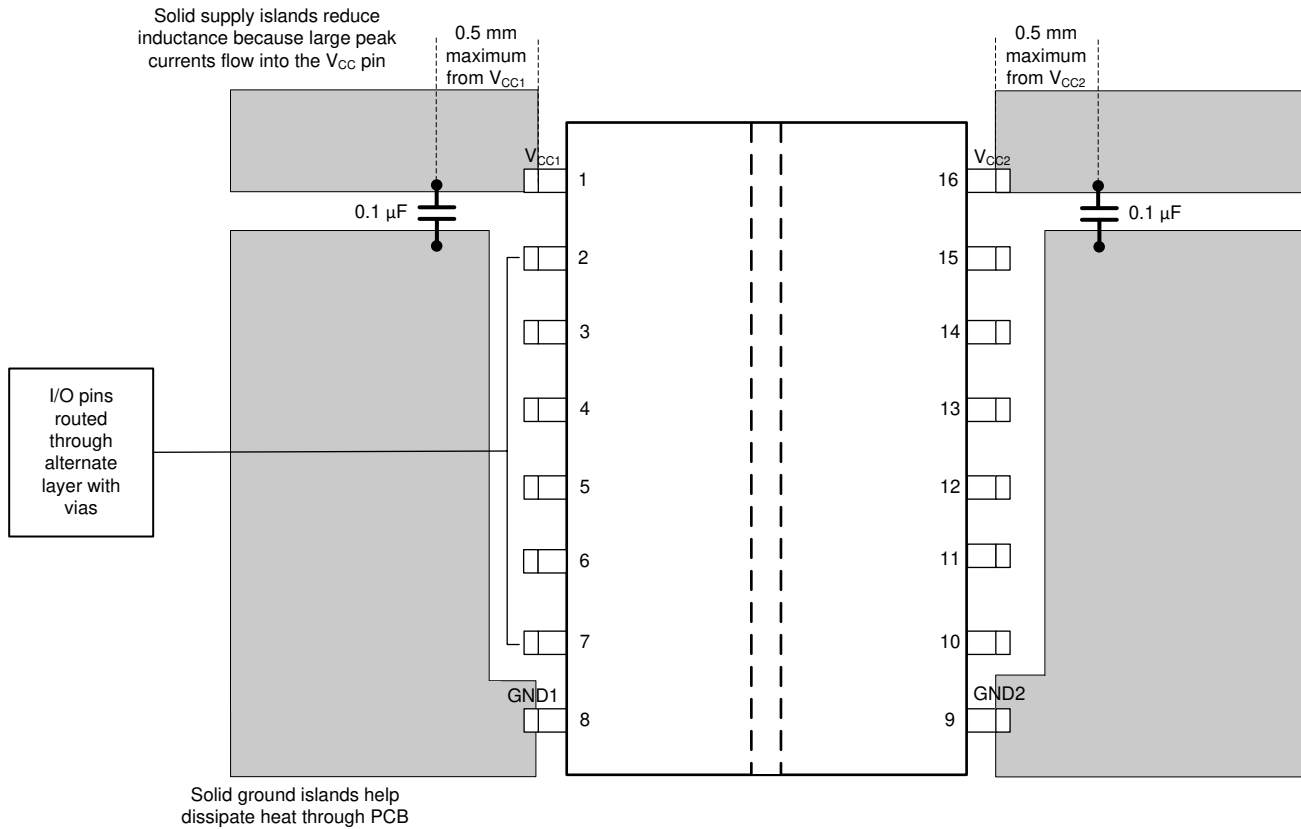
12.1 Documentation Support

12.1.1 Related Documentation

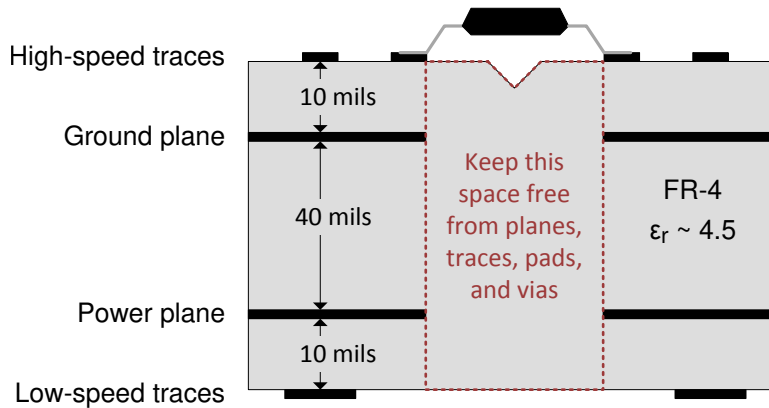
For related documentation, see the following:

- Texas Instruments, [Digital Isolator Design Guide](#)
- Texas Instruments, [Digital Isolator Design Guide](#)
- Texas Instruments, [Isolation Glossary](#)
- Texas Instruments, [How to use isolation to improve ESD, EFT, and Surge immunity in industrial systems application report](#)
- Texas Instruments, [SN6505x-Q1 Low-Noise 1-A Transformer Drivers for Isolated Power Supplies](#)
- Texas Instruments, [TCAN1044-Q1 Automotive Fault-Protected CAN FD Transceiver](#)
- Texas Instruments, [TPS763xx-Q1 Low-Power, 150-mA, Low-Dropout Linear Regulators data sheet](#)
- Texas Instruments, [TMS320F2803x Piccolo™ Microcontrollers data sheet](#)

12.2 Receiving Notification of Documentation Updates

To receive notification of documentation updates, navigate to the device product folder on ti.com. In the upper right corner, click on *Alert me* to register and receive a weekly digest of any product information that has changed. For change details, review the revision history included in any revised document.

12.3 支持资源

TI E2E™ 支持论坛是工程师的重要参考资料，可直接从专家获得快速、经过验证的解答和设计帮助。搜索现有解答或提出自己的问题可获得所需的快速设计帮助。

链接的内容由各个贡献者“按原样”提供。这些内容并不构成 TI 技术规范，并且不一定反映 TI 的观点；请参阅 TI 的《使用条款》。

12.4 Trademarks

TI E2E™ is a trademark of Texas Instruments.

所有商标均为其各自所有者的财产。

12.5 Electrostatic Discharge Caution



This integrated circuit can be damaged by ESD. Texas Instruments recommends that all integrated circuits be handled with appropriate precautions. Failure to observe proper handling and installation procedures can cause damage.

ESD damage can range from subtle performance degradation to complete device failure. Precision integrated circuits may be more susceptible to damage because very small parametric changes could cause the device not to meet its published specifications.

12.6 术语表

TI 术语表 本术语表列出并解释了术语、首字母缩略词和定义。

13 Mechanical, Packaging, and Orderable Information

The following pages include mechanical packaging and orderable information. This information is the most current data available for the designated devices. This data is subject to change without notice and revision of this document. For browser-based versions of this data sheet, refer to the left-hand navigation.

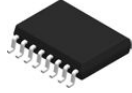

DW0016A

PACKAGE OUTLINE
SOIC - 2.65 mm max height

SOIC

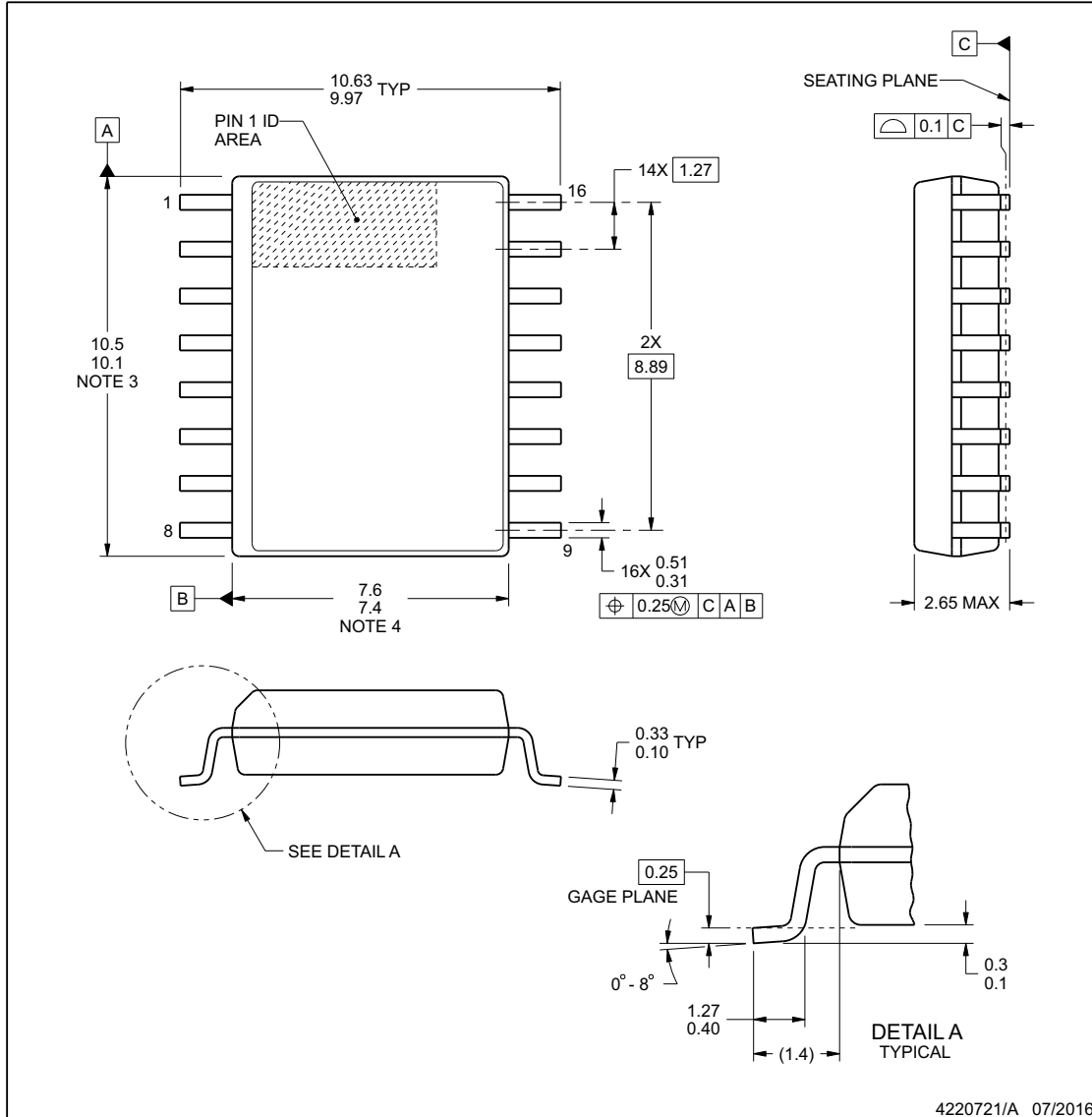

NOTES:

1. All linear dimensions are in millimeters. Dimensions in parenthesis are for reference only. Dimensioning and tolerancing per ASME Y14.5M.
2. This drawing is subject to change without notice.
3. This dimension does not include mold flash, protrusions, or gate burrs. Mold flash, protrusions, or gate burrs shall not exceed 0.15 mm, per side.
4. This dimension does not include interlead flash. Interlead flash shall not exceed 0.25 mm, per side.
5. Reference JEDEC registration MS-013.

EXAMPLE BOARD LAYOUT

DW0016A

SOIC - 2.65 mm max height

SOIC

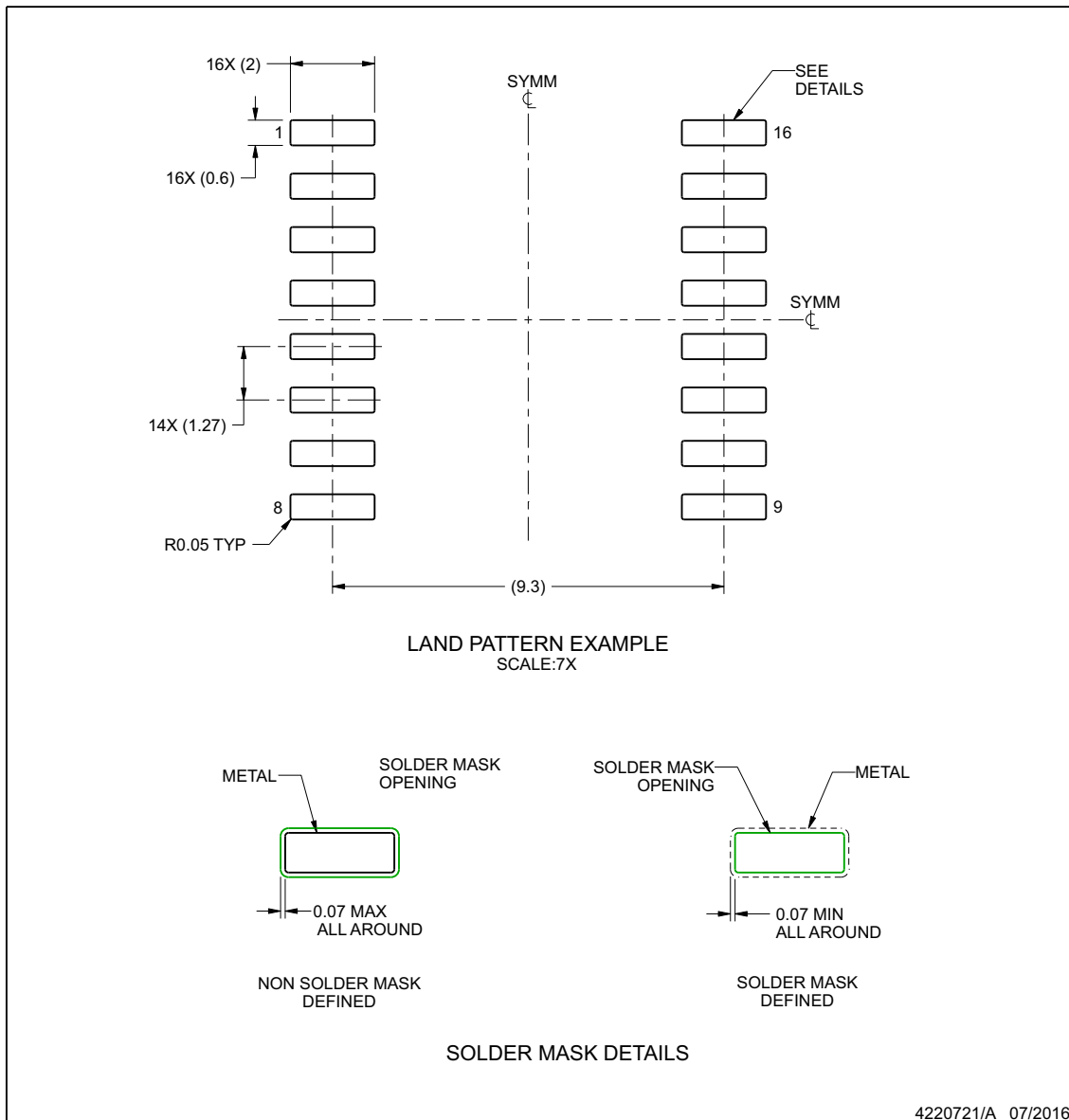

NOTES: (continued)

- 6. Publication IPC-7351 may have alternate designs.
- 7. Solder mask tolerances between and around signal pads can vary based on board fabrication site.

EXAMPLE STENCIL DESIGN

DW0016A

SOIC - 2.65 mm max height

SOIC

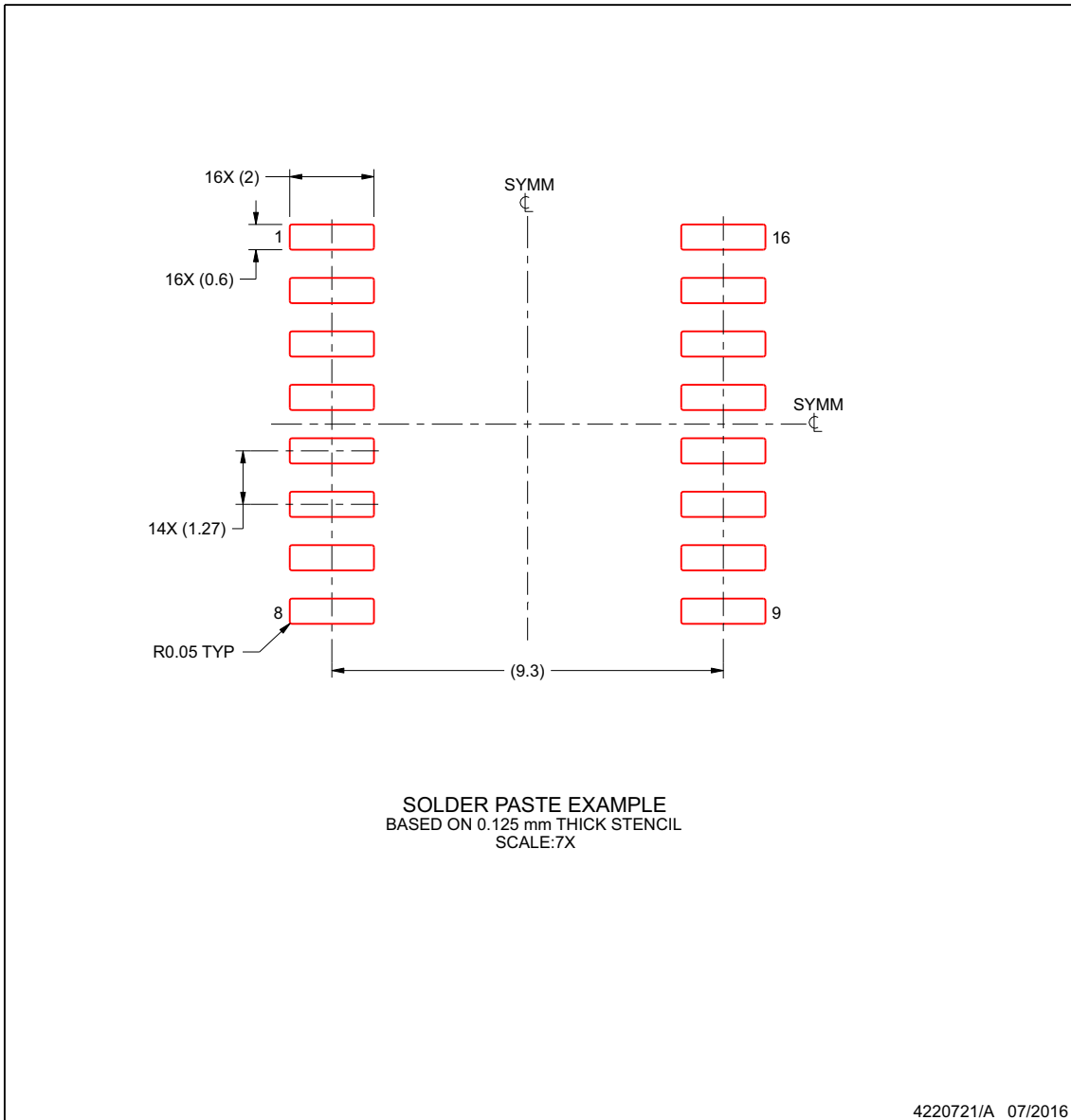

NOTES: (continued)

- 8. Laser cutting apertures with trapezoidal walls and rounded corners may offer better paste release. IPC-7525 may have alternate design recommendations.
- 9. Board assembly site may have different recommendations for stencil design.

13.1 Package Option Addendum

Packaging Information

Orderable Device	Status ⁽¹⁾	Package Type	Package Drawing	Pins	Package Qty	Eco Plan ⁽²⁾	Lead/Ball Finish ⁽⁶⁾	MSL Peak Temp ⁽³⁾	Op Temp (°C)	Device Marking ^{(4) (5)}
ISO6760QDWR Q1	ACTIVE	SOIC	DW	16	2000	Green (RoHS & no Sb/Br)	NIPDAU	Level-2-260C-1 YEAR	-40 to 125	ISO6760
ISO6760FQDWR Q1	ACTIVE	SOIC	DW	16	2000	Green (RoHS & no Sb/Br)	NIPDAU	Level-2-260C-1 YEAR	-40 to 125	ISO6760 F
ISO6761QDWR Q1	ACTIVE	SOIC	DW	16	2000	Green (RoHS & no Sb/Br)	NIPDAU	Level-2-260C-1 YEAR	-40 to 125	ISO6761
ISO6761FQDWR Q1	ACTIVE	SOIC	DW	16	2000	Green (RoHS & no Sb/Br)	NIPDAU	Level-2-260C-1 YEAR	-40 to 125	ISO6761 F
ISO6762QDWR Q1	ACTIVE	SOIC	DW	16	2000	Green (RoHS & no Sb/Br)	NIPDAU	Level-2-260C-1 YEAR	-40 to 125	ISO6762
ISO6762FQDWR Q1	ACTIVE	SOIC	DW	16	2000	Green (RoHS & no Sb/Br)	NIPDAU	Level-2-260C-1 YEAR	-40 to 125	ISO6762 F
ISO6763QDWR Q1	ACTIVE	SOIC	DW	16	2000	Green (RoHS & no Sb/Br)	NIPDAU	Level-2-260C-1 YEAR	-40 to 125	ISO6763
ISO6763FQDWR Q1	ACTIVE	SOIC	DW	16	2000	Green (RoHS & no Sb/Br)	NIPDAU	Level-2-260C-1 YEAR	-40 to 125	ISO6763 F

13.2 Tape and Reel Information

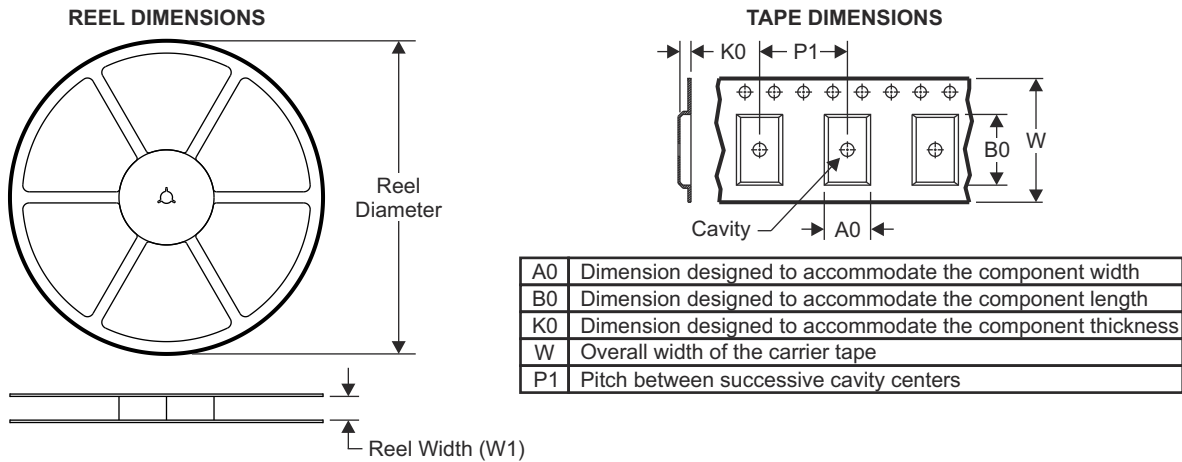

QUADRANT ASSIGNMENTS FOR PIN 1 ORIENTATION IN TAPE

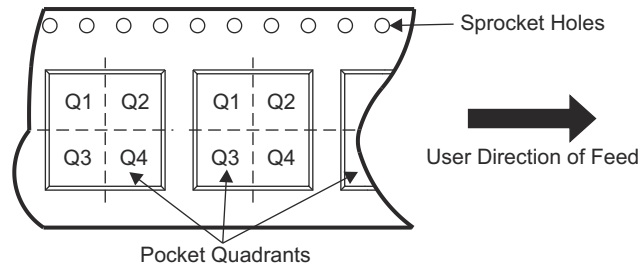

Device	Package Type	Package Drawing	Pins	SPQ	Reel Diameter (mm)	Reel Width W1 (mm)	A0 (mm)	B0 (mm)	K0 (mm)	P1 (mm)	W (mm)	Pin1 Quadrant
ISO6760QDWRQ1	SOIC	DW	16	2000	330.0	24.4	10.9	10.7	2.7	12.0	24.0	Q1
ISO6760FQDWRQ1	SOIC	DW	16	2000	330.0	24.4	10.9	10.7	2.7	12.0	24.0	Q1
ISO6761FQDWRQ1	SOIC	DW	16	2000	330.0	24.4	10.9	10.7	2.7	12.0	24.0	Q1
ISO6761QDWRQ1	SOIC	DW	16	2000	330.0	24.4	10.9	10.7	2.7	12.0	24.0	Q1
ISO6762FQDWRQ1	SOIC	DW	16	2000	330.0	24.4	10.9	10.7	2.7	12.0	24.0	Q1
ISO6762QDWRQ1	SOIC	DW	16	2000	330.0	24.4	10.9	10.7	2.7	12.0	24.0	Q1
ISO6763FQDWRQ1	SOIC	DW	16	2000	330.0	24.4	10.9	10.7	2.7	12.0	24.0	Q1
ISO6763QDWRQ1	SOIC	DW	16	2000	330.0	24.4	10.9	10.7	2.7	12.0	24.0	Q1

TAPE AND REEL BOX DIMENSIONS

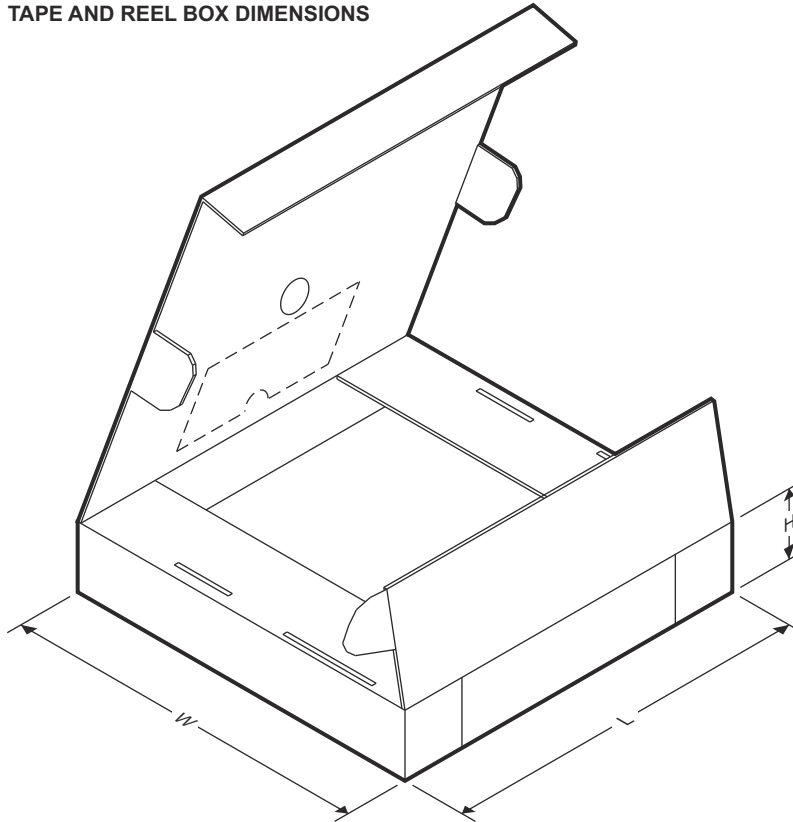

Device	Package Type	Package Drawing	Pins	SPQ	Length (mm)	Width (mm)	Height (mm)
ISO6760QDWRQ1	SOIC	DW	16	2000	367.0	367.0	45.0
ISO6760FQDWRQ1	SOIC	DW	16	2000	367.0	367.0	45.0
ISO6761FQDWRQ1	SOIC	DW	16	2000	367.0	367.0	45.0
ISO6761QDWRQ1	SOIC	DW	16	2000	367.0	367.0	45.0
ISO6762FQDWRQ1	SOIC	DW	16	2000	367.0	367.0	45.0
ISO6762QDWRQ1	SOIC	DW	16	2000	367.0	367.0	45.0
ISO6763FQDWRQ1	SOIC	DW	16	2000	367.0	367.0	45.0
ISO6763QDWRQ1	SOIC	DW	16	2000	367.0	367.0	45.0

PACKAGING INFORMATION

Orderable Device	Status (1)	Package Type	Package Drawing	Pins	Package Qty	Eco Plan (2)	Lead finish/ Ball material (6)	MSL Peak Temp (3)	Op Temp (°C)	Device Marking (4/5)	Samples
ISO6760FQDWRQ1	ACTIVE	SOIC	DW	16	2000	RoHS & Green	NIPDAU	Level-2-260C-1 YEAR	-40 to 125	ISO6760F	Samples
ISO6760QDWRQ1	ACTIVE	SOIC	DW	16	2000	RoHS & Green	NIPDAU	Level-2-260C-1 YEAR	-40 to 125	ISO6760	Samples
ISO6761FQDWRQ1	ACTIVE	SOIC	DW	16	2000	RoHS & Green	NIPDAU	Level-2-260C-1 YEAR	-40 to 125	ISO6761F	Samples
ISO6761QDWRQ1	ACTIVE	SOIC	DW	16	2000	RoHS & Green	NIPDAU	Level-2-260C-1 YEAR	-40 to 125	ISO6761	Samples
ISO6762FQDWRQ1	ACTIVE	SOIC	DW	16	2000	RoHS & Green	NIPDAU	Level-2-260C-1 YEAR	-40 to 125	ISO6762F	Samples
ISO6762QDWRQ1	ACTIVE	SOIC	DW	16	2000	RoHS & Green	NIPDAU	Level-2-260C-1 YEAR	-40 to 125	ISO6762	Samples
ISO6763FQDWRQ1	ACTIVE	SOIC	DW	16	2000	RoHS & Green	NIPDAU	Level-2-260C-1 YEAR	-40 to 125	ISO6763F	Samples
ISO6763QDWRQ1	ACTIVE	SOIC	DW	16	2000	RoHS & Green	NIPDAU	Level-2-260C-1 YEAR	-40 to 125	ISO6763	Samples

(1) The marketing status values are defined as follows:

ACTIVE: Product device recommended for new designs.

LIFEBUY: TI has announced that the device will be discontinued, and a lifetime-buy period is in effect.

NRND: Not recommended for new designs. Device is in production to support existing customers, but TI does not recommend using this part in a new design.

PREVIEW: Device has been announced but is not in production. Samples may or may not be available.

OBSELETE: TI has discontinued the production of the device.

(2) **RoHS:** TI defines "RoHS" to mean semiconductor products that are compliant with the current EU RoHS requirements for all 10 RoHS substances, including the requirement that RoHS substance do not exceed 0.1% by weight in homogeneous materials. Where designed to be soldered at high temperatures, "RoHS" products are suitable for use in specified lead-free processes. TI may reference these types of products as "Pb-Free".

RoHS Exempt: TI defines "RoHS Exempt" to mean products that contain lead but are compliant with EU RoHS pursuant to a specific EU RoHS exemption.

Green: TI defines "Green" to mean the content of Chlorine (Cl) and Bromine (Br) based flame retardants meet JS709B low halogen requirements of <=1000ppm threshold. Antimony trioxide based flame retardants must also meet the <=1000ppm threshold requirement.

(3) MSL, Peak Temp. - The Moisture Sensitivity Level rating according to the JEDEC industry standard classifications, and peak solder temperature.

(4) There may be additional marking, which relates to the logo, the lot trace code information, or the environmental category on the device.

(5) Multiple Device Markings will be inside parentheses. Only one Device Marking contained in parentheses and separated by a "~" will appear on a device. If a line is indented then it is a continuation of the previous line and the two combined represent the entire Device Marking for that device.

⁽⁶⁾ Lead finish/Ball material - Orderable Devices may have multiple material finish options. Finish options are separated by a vertical ruled line. Lead finish/Ball material values may wrap to two lines if the finish value exceeds the maximum column width.

Important Information and Disclaimer: The information provided on this page represents TI's knowledge and belief as of the date that it is provided. TI bases its knowledge and belief on information provided by third parties, and makes no representation or warranty as to the accuracy of such information. Efforts are underway to better integrate information from third parties. TI has taken and continues to take reasonable steps to provide representative and accurate information but may not have conducted destructive testing or chemical analysis on incoming materials and chemicals. TI and TI suppliers consider certain information to be proprietary, and thus CAS numbers and other limited information may not be available for release.

In no event shall TI's liability arising out of such information exceed the total purchase price of the TI part(s) at issue in this document sold by TI to Customer on an annual basis.

OTHER QUALIFIED VERSIONS OF ISO6760-Q1, ISO6761-Q1, ISO6762-Q1, ISO6763-Q1 :

- Catalog : [ISO6760](#), [ISO6761](#), [ISO6762](#), [ISO6763](#)

NOTE: Qualified Version Definitions:

- Catalog - TI's standard catalog product

TAPE AND REEL INFORMATION

QUADRANT ASSIGNMENTS FOR PIN 1 ORIENTATION IN TAPE

*All dimensions are nominal

Device	Package Type	Package Drawing	Pins	SPQ	Reel Diameter (mm)	Reel Width W1 (mm)	A0 (mm)	B0 (mm)	K0 (mm)	P1 (mm)	W (mm)	Pin1 Quadrant
ISO6760FQDWRQ1	SOIC	DW	16	2000	330.0	24.4	10.9	10.7	2.7	12.0	24.0	Q1
ISO6760QDWRQ1	SOIC	DW	16	2000	330.0	24.4	10.9	10.7	2.7	12.0	24.0	Q1
ISO6761FQDWRQ1	SOIC	DW	16	2000	330.0	24.4	10.9	10.7	2.7	12.0	24.0	Q1
ISO6761QDWRQ1	SOIC	DW	16	2000	330.0	24.4	10.9	10.7	2.7	12.0	24.0	Q1
ISO6762FQDWRQ1	SOIC	DW	16	2000	330.0	24.4	10.9	10.7	2.7	12.0	24.0	Q1
ISO6762QDWRQ1	SOIC	DW	16	2000	330.0	24.4	10.9	10.7	2.7	12.0	24.0	Q1
ISO6763FQDWRQ1	SOIC	DW	16	2000	330.0	24.4	10.9	10.7	2.7	12.0	24.0	Q1
ISO6763QDWRQ1	SOIC	DW	16	2000	330.0	24.4	10.9	10.7	2.7	12.0	24.0	Q1

TAPE AND REEL BOX DIMENSIONS

*All dimensions are nominal

Device	Package Type	Package Drawing	Pins	SPQ	Length (mm)	Width (mm)	Height (mm)
ISO6760FQDWRQ1	SOIC	DW	16	2000	367.0	367.0	45.0
ISO6760QDWRQ1	SOIC	DW	16	2000	367.0	367.0	45.0
ISO6761FQDWRQ1	SOIC	DW	16	2000	367.0	367.0	45.0
ISO6761QDWRQ1	SOIC	DW	16	2000	367.0	367.0	45.0
ISO6762FQDWRQ1	SOIC	DW	16	2000	367.0	367.0	45.0
ISO6762QDWRQ1	SOIC	DW	16	2000	367.0	367.0	45.0
ISO6763FQDWRQ1	SOIC	DW	16	2000	367.0	367.0	45.0
ISO6763QDWRQ1	SOIC	DW	16	2000	367.0	367.0	45.0

GENERIC PACKAGE VIEW

DW 16

SOIC - 2.65 mm max height

7.5 x 10.3, 1.27 mm pitch

SMALL OUTLINE INTEGRATED CIRCUIT

This image is a representation of the package family, actual package may vary.
Refer to the product data sheet for package details.



4224780/A



DW0016A

PACKAGE OUTLINE

SOIC - 2.65 mm max height

SOIC

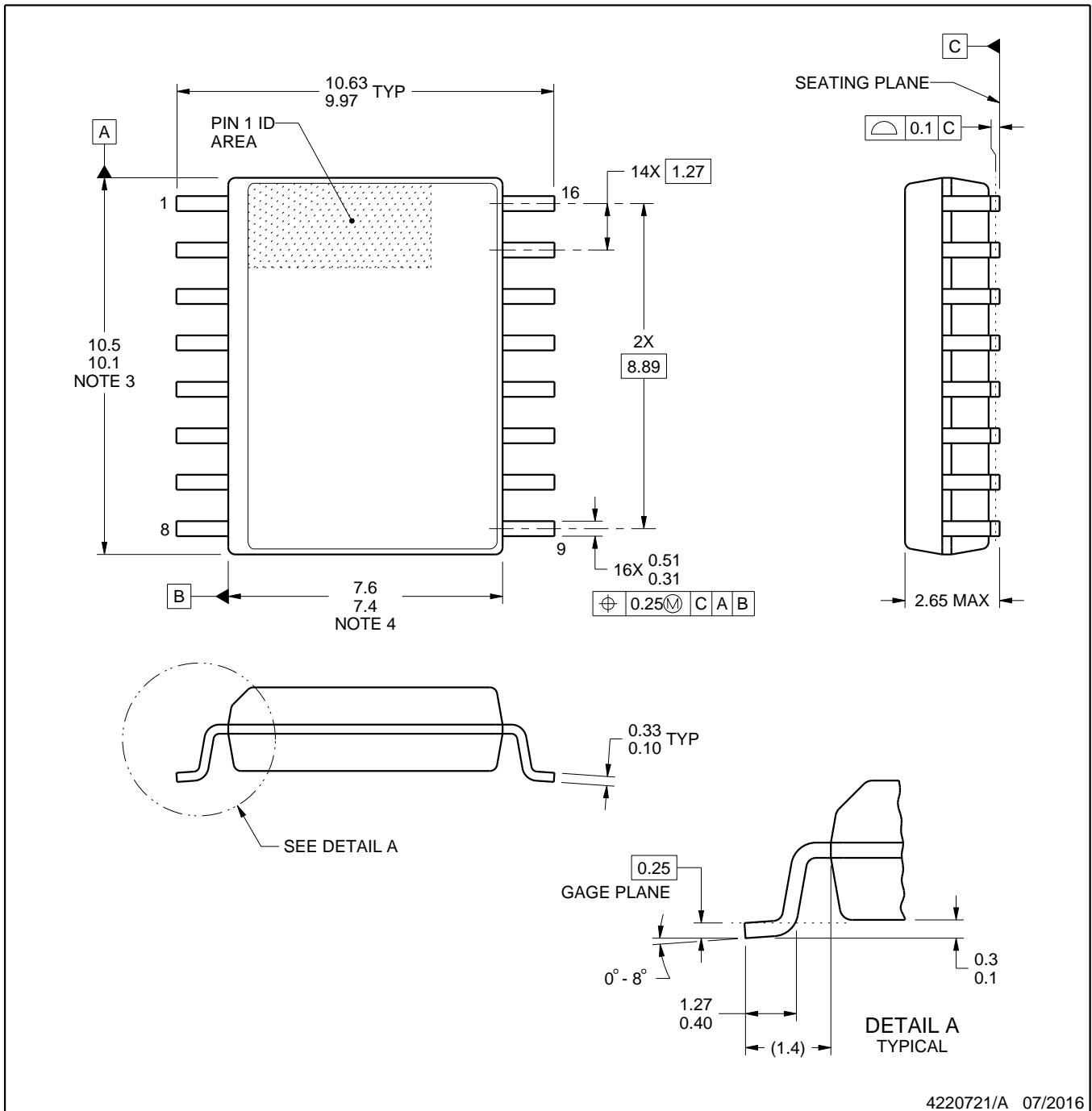

4220721/A 07/2016

NOTES:

1. All linear dimensions are in millimeters. Dimensions in parenthesis are for reference only. Dimensioning and tolerancing per ASME Y14.5M.
2. This drawing is subject to change without notice.
3. This dimension does not include mold flash, protrusions, or gate burrs. Mold flash, protrusions, or gate burrs shall not exceed 0.15 mm, per side.
4. This dimension does not include interlead flash. Interlead flash shall not exceed 0.25 mm, per side.
5. Reference JEDEC registration MS-013.

EXAMPLE BOARD LAYOUT

DW0016A

SOIC - 2.65 mm max height

SOIC



LAND PATTERN EXAMPLE
SCALE:7X



SOLDER MASK DETAILS

4220721/A 07/2016

NOTES: (continued)

6. Publication IPC-7351 may have alternate designs.

7. Solder mask tolerances between and around signal pads can vary based on board fabrication site.

EXAMPLE STENCIL DESIGN

DW0016A

SOIC - 2.65 mm max height

SOIC



SOLDER PASTE EXAMPLE
BASED ON 0.125 mm THICK STENCIL
SCALE:7X

4220721/A 07/2016

NOTES: (continued)

8. Laser cutting apertures with trapezoidal walls and rounded corners may offer better paste release. IPC-7525 may have alternate design recommendations.
9. Board assembly site may have different recommendations for stencil design.

重要声明和免责声明

TI“按原样”提供技术和可靠性数据（包括数据表）、设计资源（包括参考设计）、应用或其他设计建议、网络工具、安全信息和其他资源，不保证没有瑕疵且不做任何明示或暗示的担保，包括但不限于对适销性、某特定用途方面的适用性或不侵犯任何第三方知识产权的暗示担保。

这些资源可供使用 TI 产品进行设计的熟练开发人员使用。您将自行承担以下全部责任：(1) 针对您的应用选择合适的 TI 产品，(2) 设计、验证并测试您的应用，(3) 确保您的应用满足相应标准以及任何其他功能安全、信息安全、监管或其他要求。

这些资源如有变更，恕不另行通知。TI 授权您仅可将这些资源用于研发本资源所述的 TI 产品的应用。严禁对这些资源进行其他复制或展示。您无权使用任何其他 TI 知识产权或任何第三方知识产权。您应全额赔偿因在这些资源的使用中对 TI 及其代表造成的任何索赔、损害、成本、损失和债务，TI 对此概不负责。

TI 提供的产品受 [TI 的销售条款](#) 或 [ti.com](#) 上其他适用条款/TI 产品随附的其他适用条款的约束。TI 提供这些资源并不会扩展或以其他方式更改 TI 针对 TI 产品发布的适用的担保或担保免责声明。

TI 反对并拒绝您可能提出的任何其他或不同的条款。

邮寄地址：Texas Instruments, Post Office Box 655303, Dallas, Texas 75265

Copyright © 2022，德州仪器 (TI) 公司

X-ON Electronics

Largest Supplier of Electrical and Electronic Components

Click to view similar products for [Digital Isolators](#) category:

Click to view products by [Texas Instruments](#) manufacturer:

Other Similar products are found below :

[SI8642EA-B-IU](#) [141E61](#) [140M31](#) [140E60](#) [122E61](#) [142E60](#) [163E60](#) [141E61Q](#) [140E61](#) [SSP5841ED](#) [CA-IS3763LN](#) [CA-IS3742LN](#)
[SSP5842ED](#) [160M60](#) [142E61](#) [140E31](#) [140M30](#) [141E60Q](#) [140M61](#) [160U31](#) [BL7142WH](#) [BL7142WL](#) [CA-IS3741LN](#) [CA-IS3762LN](#) [CA-](#)
[IS3730LW](#) [CA-IS3644HVW](#) [CA-IS3742LW-Q1](#) [CA-IS1204W](#) [CA-IS3641HVW](#) [CA-IS3092VW](#) [CA-IS3761LN](#) [CA-IS3760HN](#) [CA-](#)
[IS3730HW](#) [CA-IS3731LW](#) [CA-IS3640LW](#) [CA-IS3761LW](#) [CA-IS2092VW](#) [CA-IS3763HN](#) [CA-IS3722HW](#) [CA-IS3211VBJ](#) [CA-](#)
[IS3082WNX](#) [CA-IS3762LW](#) [CA-IS3842LWW](#) [CA-IS3720LW](#) [SI8621BD-B-IS](#) [ISO7842FDWWR](#) [161E60](#) [163U31](#) [140U31](#) [161E61](#)