

ISOUSB211DPEVM Isolated USB Evaluation Module



ABSTRACT

This user's guide describes the ISOUSB211 single-channel digital isolated USB evaluation module (EVM). This EVM lets designers evaluate device performance for fast development and analysis of isolated systems. The EVM supports evaluation of ISOUSB211 in a 28-pin SSOP (DP-29) package.

CAUTION

This evaluation module is made available for isolator parameter performance evaluation only and is not intended for isolation voltage testing. To prevent damage to the EVM, any voltage applied as a supply or digital input/output must be maintained within the 0-V to 5.5-V recommended operating range.

Table of Contents

1 Introduction.....	2
2 Overview.....	2
3 Pin Configuration of the ISOUSB211 High-, Full-, and Low-Speed Isolated USB Repeater.....	3
4 EVM Setup and Operation.....	4
5 EVM Schematics.....	6
6 PCB Layout and 3D Diagram.....	7
7 Bill of Materials.....	11

List of Figures

Figure 3-1. ISOUSB211 High-, Full-, and Low-Speed Speed Isolated USB Repeater Pin Configuration.....	3
Figure 4-1. ISOUSB211 Test Setup.....	4
Figure 5-1. ISOUSB211DPEVM Schematic.....	6
Figure 6-1. ISOUSB211DPEVM PCB Layout - Top Layer.....	7
Figure 6-2. ISOUSB211DPEVM PCB Layout - Middle Layer.....	8
Figure 6-3. ISOUSB211DPEVM PCB Layout - Bottom Layer.....	9
Figure 6-4. ISOUSB211DPEVM PCB 3D View.....	10

List of Tables

Table 4-1. Resistor Configurations.....	4
Table 7-1. Bill of Materials.....	11

Trademarks

All trademarks are the property of their respective owners.

1 Introduction

This user's guide describes EVM operation with respect to the ISOUSB211 single-channel isolated high-, full-, and low-speed USB 2.0 repeater. This guide also describes the EVM BOM, EVM schematic, EVM PCB layout, and typical laboratory setup.

2 Overview

The ISOUSB211 device is a galvanically-isolated USB 2.0 compliant repeater supporting low-speed (1.5 Mbps), full-speed (12 Mbps), and high-speed (480 Mbps) signaling rates. The device supports automatic connect and speed detection, reflection of pullups and pulldowns, and link power management allowing drop-in USB hub, host, peripheral and cable isolation. The device also supports automatic role reversal - if after disconnect, a new connection is detected on the upstream facing port, then the upstream and downstream port definitions are reversed. The ISOUSB211 has built-in programmable equalization to cancel signal loss caused by board traces, which helps in meeting USB 2.0 high-speed TX and RX eye-diagram templates. This device uses a silicon dioxide (SiO_2) insulation barrier with a withstand voltage of 5700 V_{RMS} and a working voltage of 1060 V_{RMS} . Used in conjunction with isolated power supplies, the device protects against high voltage, and prevents noise currents from the bus from entering the local ground. The ISOUSB211 device is available for both basic and reinforced isolation. The ISOUSB211 device supports a wide ambient temperature range of -40°C to $+115^\circ\text{C}$. The device is available in the small footprint 28-pin SSOP (DP-28) package.

The EVM enables users to evaluate the ISOUSB211 device thoroughly before incorporating the device into their designs. To facilitate the EVM to be powered from various power sources including regulated power supplies, standard USB2.0 connector, and standard DC adapter, the EVM includes a transformer driver (SN6501), a transformer (CMP-0030614-1), and five adjustable output LDOs (TPS76701 and TPS73701). This EVM can be configured to use the provided LDOs to power the 3.3-V and 1.8-V power supplies, or bypass these external LDOs and use the internal LDOs to power the 3.3-V and 1.8-V power supplies. The EVM can be configured to operate with and without external LDOs and test configurations details of which are provided in the following sections.

The EVM can be used to verify many of the ISOUSB211 data sheet parameters like data-rate, current consumption, and others. Some of the data sheet specifications require a different test setup configuration than the ISOUSB211DPEVM and hence, they cannot be verified from the EVM as is. The example parameters include maximum data rate, propagation delay, and other timing specifications.

3 Pin Configuration of the ISOUSB211 High-, Full-, and Low-Speed Isolated USB Repeater

Figure 3-1 shows the ISOUSB211 high-, full-, and low-speed isolated USB repeater pin configuration.

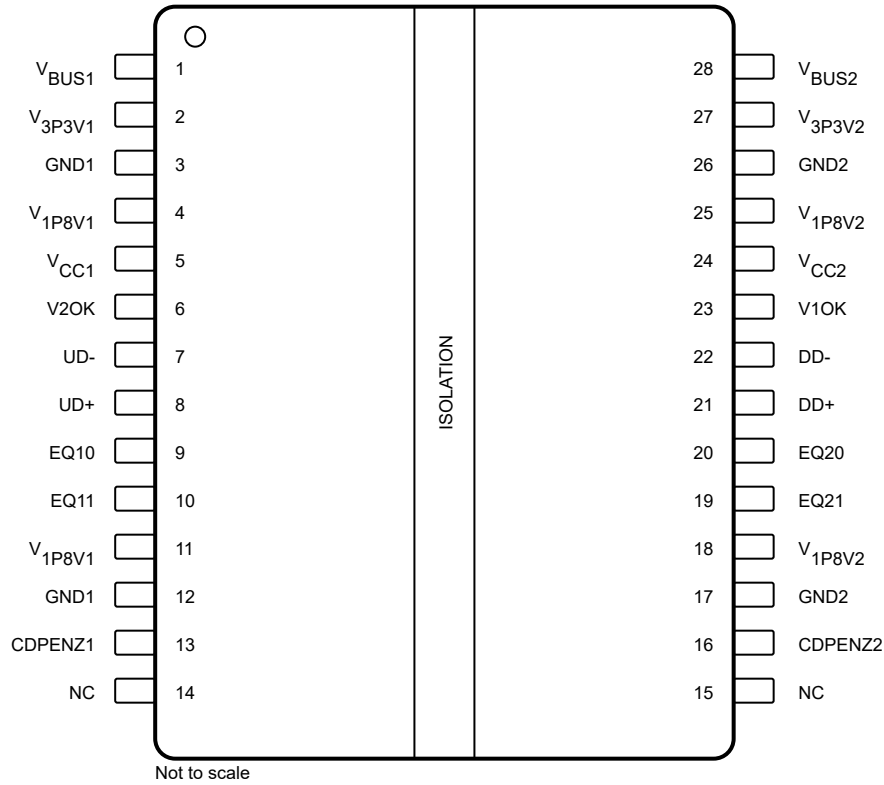

Figure 3-1. ISOUSB211 High-, Full-, and Low-Speed Speed Isolated USB Repeater Pin Configuration

4 EVM Setup and Operation

This section describes the typical setup and operation of the EVM for device evaluation. Figure 4-1 shows a typical test configuration for operating the ISOUSB211DPEVM using an USB 2.0 type-B receptacle.

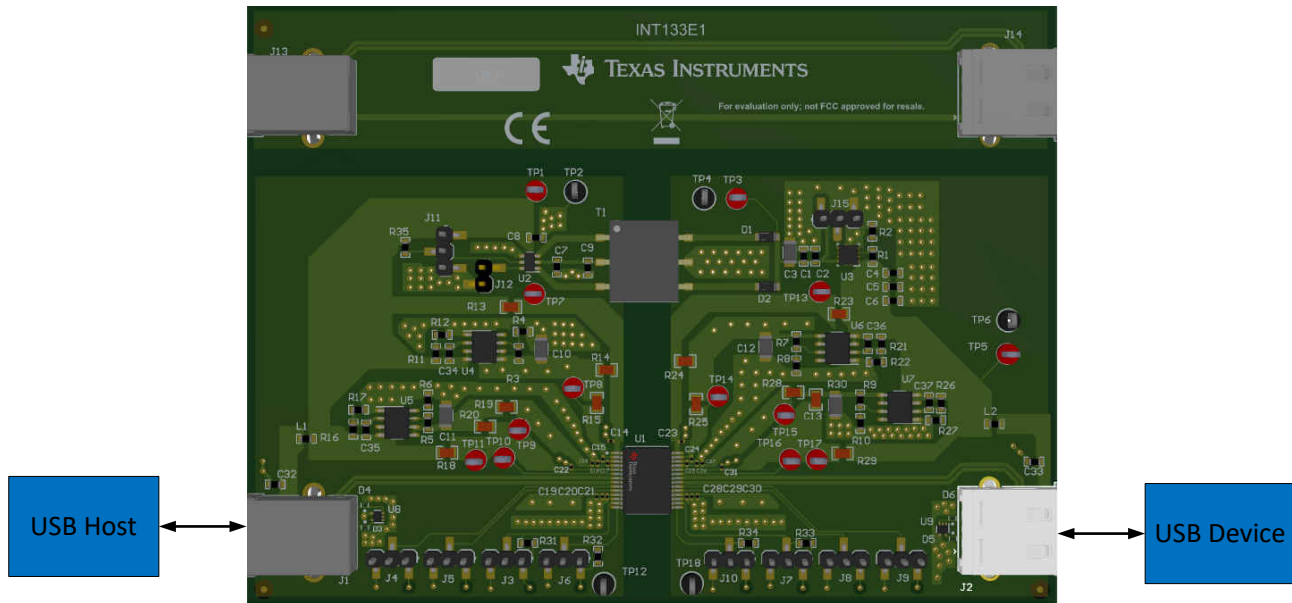

Figure 4-1. ISOUSB211 Test Setup

Use a jumper to connect pin 2 to pin 1 of J15 to enable the U3 LDO. The U3 LDO provides a 5-V supply to the USB device, and it also powers the U6 and U7 LDOs to generate 3.3 V and 1.8 V for the ISOUSB211. If an external 5-V source is used to power the USB device through TP5, connect pin 2 to pin 3 of J15 to disable the U3 LDO and set its output to high impedance.

ISOUSB211DPEVM has many DNP resistors which can be populated or unpopulated to setup the EVM to the desired operating test conditions. Table 4-1 lists and describes all the possible test configurations that can be achieved by populating various resistors.

Table 4-1. Resistor Configurations

Resistor	Description
R11	DNP by default. To disable the U4 LDO, populate a 0-Ω resistor on R11 and unpopulate R12.
R12	Connects U4 \overline{EN} to ground to enable the LDO. When R12 is populated, unpopulate R11.
R13	Connects V_{BUS1} to the type-B receptacle VBUS. V_{BUS1} is powered at 5 V when R13 is populated. Unpopulate R14 and R15 to disconnect the U4 LDO from the V_{BUS1} and V_{3P3V1} pins. The internal LDO of ISOUSB211 generates 3.3 V for the V_{3P3V1} pin.
R14, R15	DNP by default. Populating R14 and R15 connects the U4 LDO to the V_{BUS1} and V_{3P3V1} pins. When these two resistors are populated, unpopulate R13. When R14 and R15 are populated, V_{BUS1} and V_{3P3V1} are set to 3.3 V.
R16	DNP by default. To disable the U5 LDO, populate a 0-Ω resistor on R16 and unpopulate R17.
R17	Connects U5 \overline{EN} to ground to enable the LDO. When R17 is populated, unpopulate R16.
R18	Connects V_{CC1} to the VBUS of the type-B receptacle. V_{CC1} is powered at 5 V when R18 is populated. Unpopulate the R19 and R20 resistors to disconnect the U5 LDO from the V_{CC1} and V_{1P8V1} pins. The internal LDO of the ISOUSB211 generates 1.8 V for the V_{1P8V1} pin.
R19, R20	Populating R19 and R20 connects the U5 LDO to the V_{CC1} and V_{1P8V1} pins. When these two resistors are populated, unpopulate R18. When R19 and R20 are populated, V_{CC1} and V_{1P8V1} are set to 1.8 V.
R21	DNP by default. To disable the U6 LDO, populate a 0-Ω resistor on R21 and unpopulate R22.
R22	Connects U6 \overline{EN} to ground to enable the LDO. When R22 is populated, unpopulate R21.
R23	DNP by default. The R23 resistor connects V_{BUS2} to the output of U3 LDO. V_{BUS2} is powered at 5 V when R23 is populated. Unpopulate the R24 and R25 resistors to disconnect the U3 LDO from the V_{BUS2} and V_{3P3V2} pins. The internal LDO of ISOUSB211 generates 3.3 V for the V_{3P3V2} pin.

Table 4-1. Resistor Configurations (continued)

Resistor	Description
R24, R25	Populating R24 and R25 connects the U6 LDO to the V_{BUS2} and V_{3P3V2} pins. When these two resistors are populated, unpopulate R23 . When R24 and R25 are populated, V_{BUS2} and V_{3P3V2} are set to 3.3 V by the U6 LDO.
R26	DNP by default. To disable the U7 LDO, populate a 0- Ω resistor on R26 and unpopulate R27.
R27	Connects U7 \overline{EN} to ground to enable the LDO. When R27 is populated, unpopulate R26.
R29	DNP by default. The R29 resistor connects V_{BUS2} to the output of U7 LDO. V_{CC2} is powered at 5 V when R29 is populated. Unpopulate R28 and R30 to disconnect the U7 LDO from the V_{CC2} and V_{1P8V2} pins. The internal LDO of ISOUSB211 generates 1.8 V for the V_{1P8V2} pin.
R28, R30	Populating R28 and R30 connects the U7 LDO to the V_{CC2} and V_{1P8V2} pins. When these two resistors are populated, unpopulate R29. When R28 and R30 are populated, V_{CC2} and V_{1P8V2} are set to 1.8 V.

5 EVM Schematics

The ISOUSB211DPEVM is designed to accommodate any of the ISOUSB211 isolated high-, full-, or low-speed USB repeaters in a 28-pin SSOP (DP-28) package. Figure 5-1 shows the ISOUSB211DPEVM schematic.

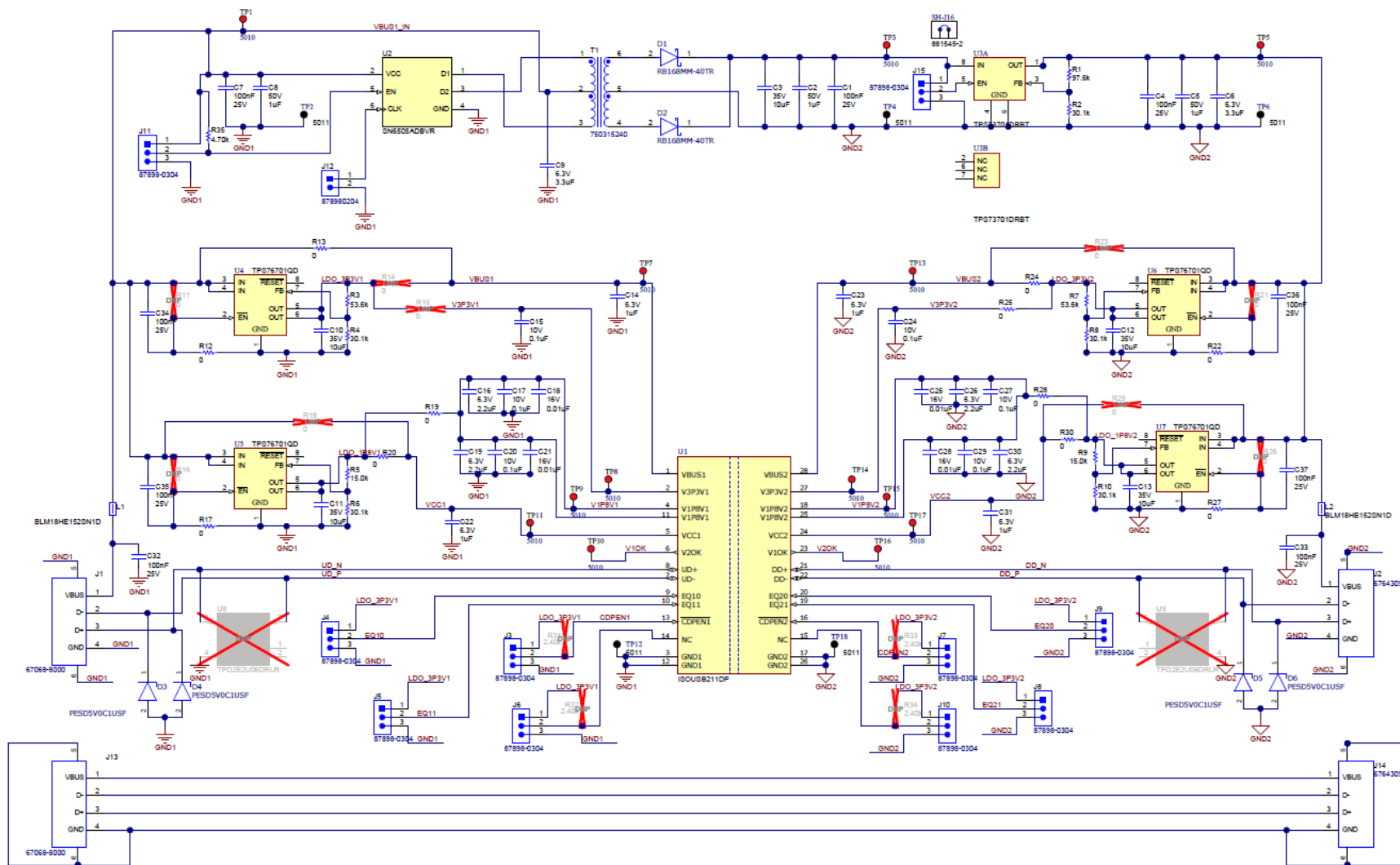

Figure 5-1. ISOUSB211DPEVM Schematic

6 PCB Layout and 3D Diagram

Figure 6-1 through Figure 6-3 show the printed-circuit board (PCB) layout top, middle and bottom layers, respectively. Figure 6-4 shows a 3D diagram of the PCB indicating the look of a finished board.

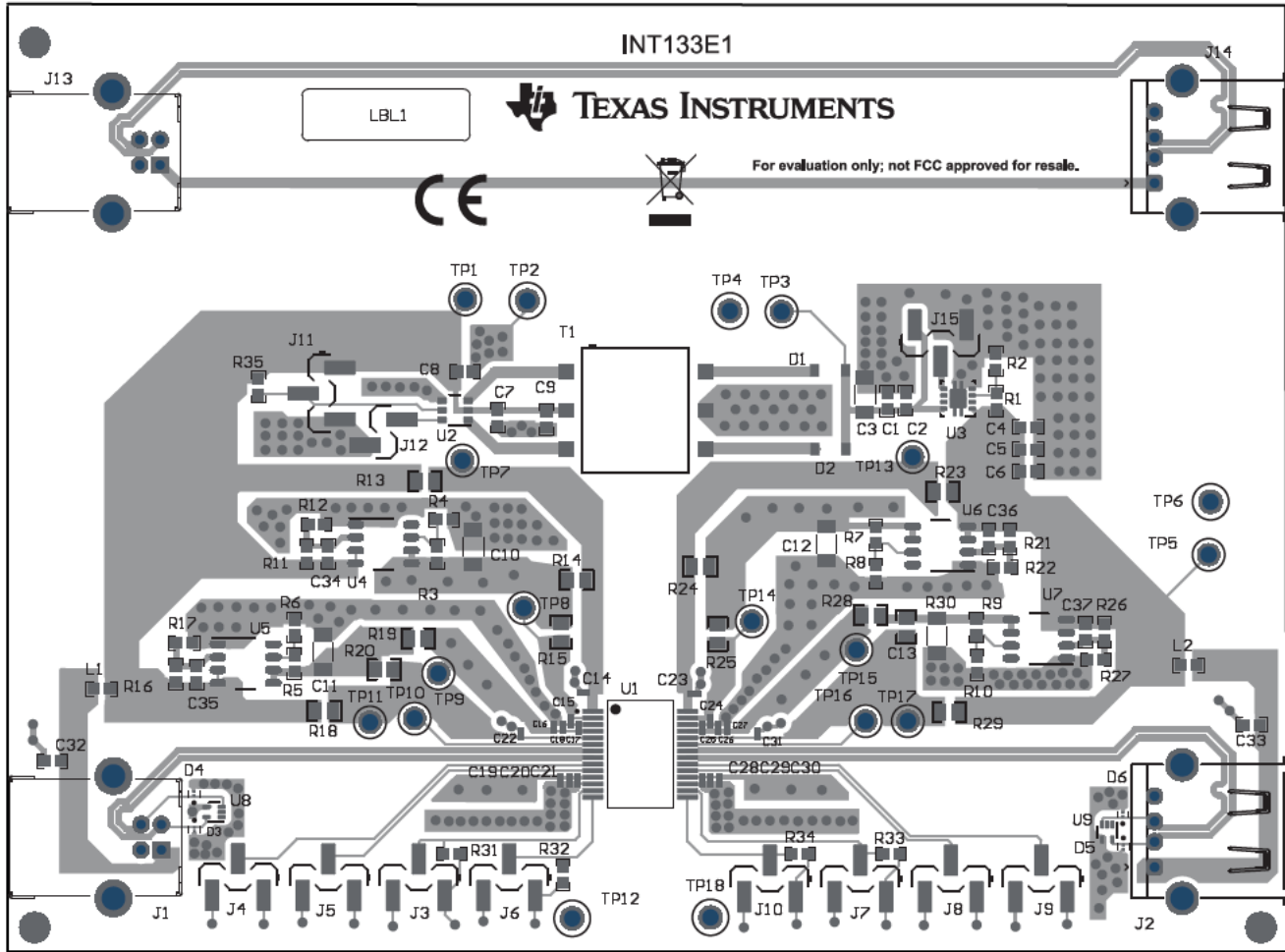

Figure 6-1. ISOUSB211DPEVM PCB Layout - Top Layer

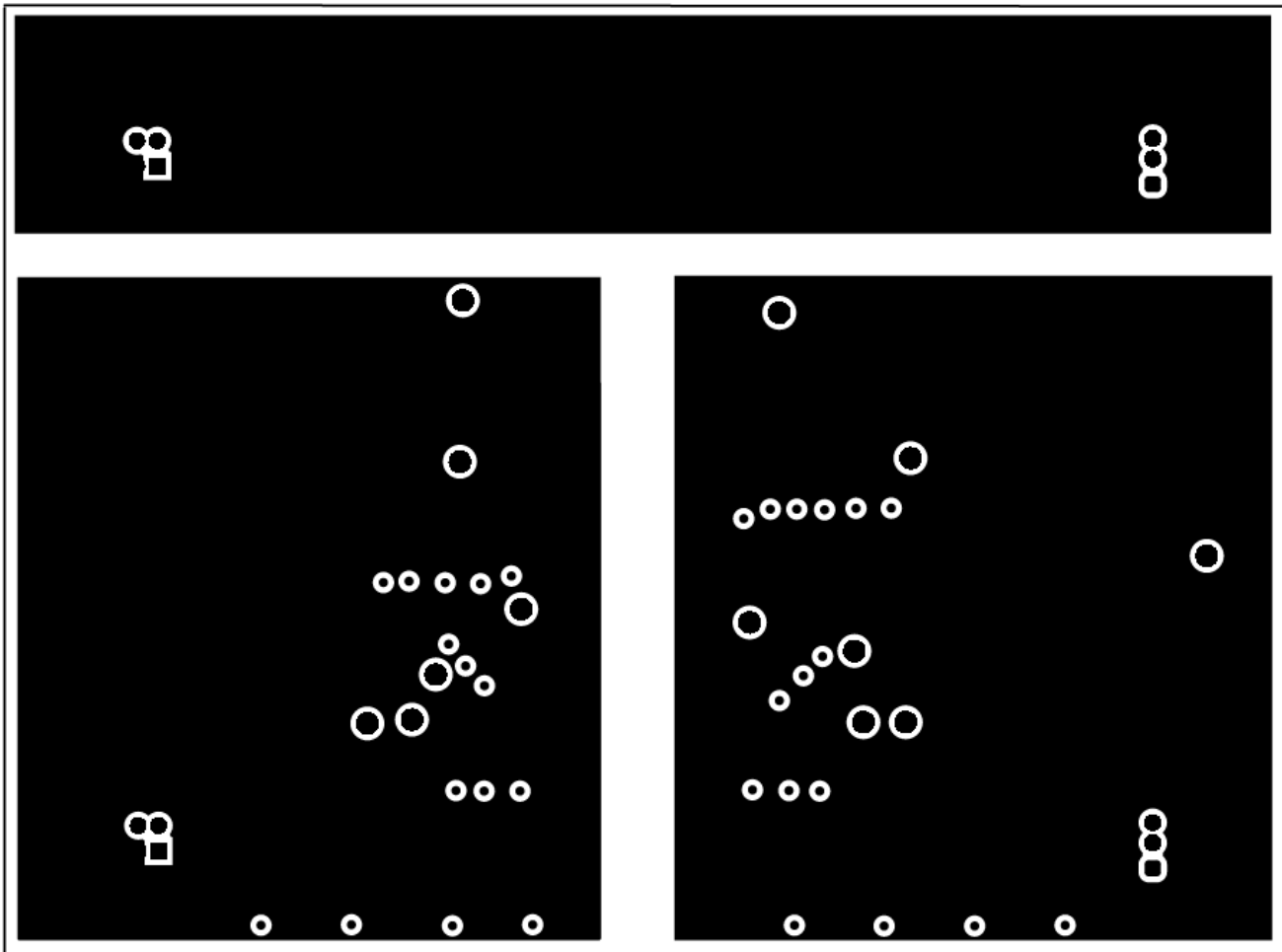

Figure 6-2. ISOUSB211DPEVM PCB Layout - Middle Layer

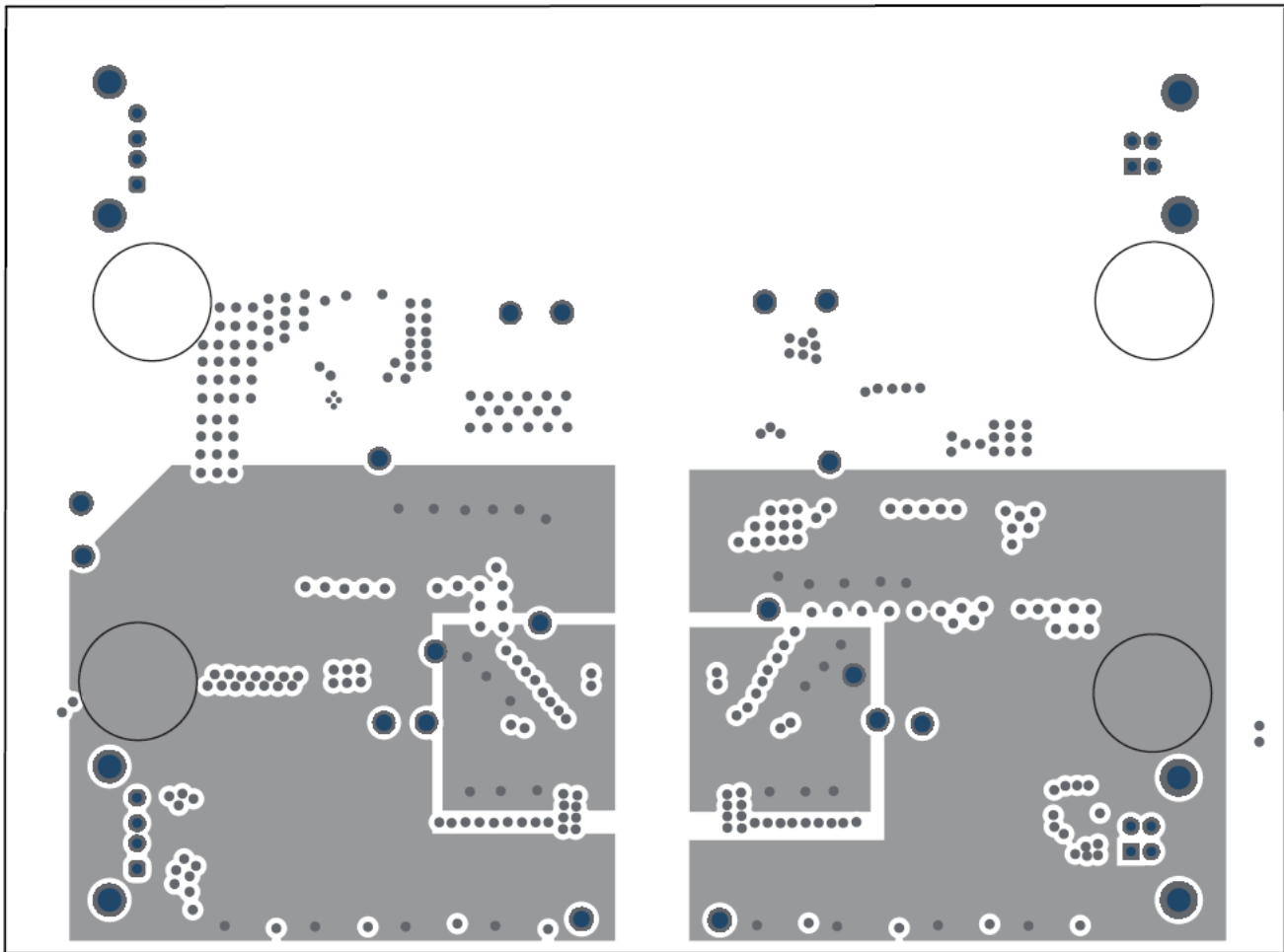

Figure 6-3. ISOUSB211DPEVM PCB Layout - Bottom Layer

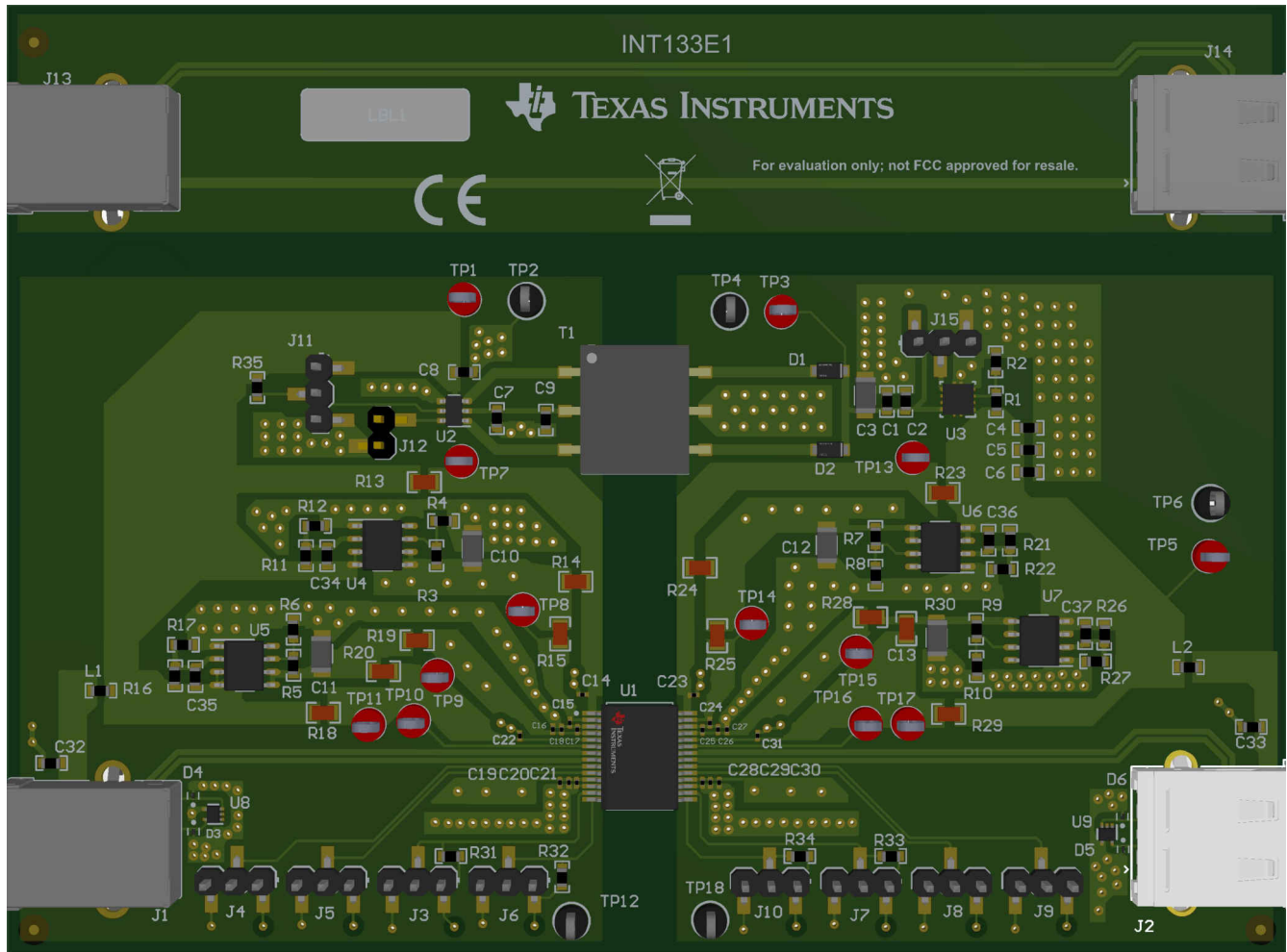

Figure 6-4. ISOUSB211DPEVM PCB 3D View

7 Bill of Materials

Table 7-1 lists the bill of materials (BOM) for this EVM.

Table 7-1. Bill of Materials

Item	Designator	Description	Manufacturer	PartNumber
1	C1	CAP, CERM, 0.1 μ F, 25 V, \pm 5%, X7R, 0603	AVX	06033C104JAT2A
2	C2	CAP, CERM, 1 μ F, 50 V, \pm 10%, X5R, 0603	TDK	C1608X5R1H105K080AB
3	C3	CAP, CERM, 10 μ F, 35 V, \pm 10%, X7R, AEC-Q200 Grade 1, 1206_190	TDK	CGA5L1X7R1V106K160AC
4	C4	CAP, CERM, 0.1 μ F, 25 V, \pm 5%, X7R, 0603	AVX	06033C104JAT2A
5	C5	CAP, CERM, 1 μ F, 50 V, \pm 10%, X5R, 0603	TDK	C1608X5R1H105K080AB
6	C6	CAP, CERM, 3.3 μ F, 6.3 V, \pm 10%, X5R, 0603	Kemet	C0603C335K9PACTU
7	C7	CAP, CERM, 0.1 μ F, 25 V, \pm 5%, X7R, 0603	AVX	06033C104JAT2A
8	C8	CAP, CERM, 1 μ F, 50 V, \pm 10%, X5R, 0603	TDK	C1608X5R1H105K080AB
9	C9	CAP, CERM, 3.3 μ F, 6.3 V, \pm 10%, X5R, 0603	Kemet	C0603C335K9PACTU
10	C10	CAP, CERM, 10 μ F, 35 V, \pm 10%, X7R, AEC-Q200 Grade 1, 1206_190	TDK	CGA5L1X7R1V106K160AC
11	C11	CAP, CERM, 10 μ F, 35 V, \pm 10%, X7R, AEC-Q200 Grade 1, 1206_190	TDK	CGA5L1X7R1V106K160AC
12	C12	CAP, CERM, 10 μ F, 35 V, \pm 10%, X7R, AEC-Q200 Grade 1, 1206_190	TDK	CGA5L1X7R1V106K160AC
13	C13	CAP, CERM, 10 μ F, 35 V, \pm 10%, X7R, AEC-Q200 Grade 1, 1206_190	TDK	CGA5L1X7R1V106K160AC
14	C14	CAP, CERM, 1 μ F, 6.3 V, \pm 20%, X5R, 0201	MuRata	GRM033R60J105MEA2D
15	C15	CAP, CERM, 0.1 μ F, 10 V, \pm 10%, X5R, 0201	Samsung Electro-Mechanics	CL03A104KP3NNNC
16	C16	CAP, CERM, 2.2 μ F, 6.3 V, \pm 20%, X5R, 0201	Samsung Electro-Mechanics	CL03A225MQ3CRNC
17	C17	CAP, CERM, 0.1 μ F, 10 V, \pm 10%, X5R, 0201	Samsung Electro-Mechanics	CL03A104KP3NNNC
18	C18	CAP, CERM, 0.01 μ F, 16 V, \pm 10%, X5R, 0201	MuRata	GRM033R61C103KA12D
19	C19	CAP, CERM, 2.2 μ F, 6.3 V, \pm 20%, X5R, 0201	Samsung Electro-Mechanics	CL03A225MQ3CRNC
20	C20	CAP, CERM, 0.1 μ F, 10 V, \pm 10%, X5R, 0201	Samsung Electro-Mechanics	CL03A104KP3NNNC
21	C21	CAP, CERM, 0.01 μ F, 16 V, \pm 10%, X5R, 0201	MuRata	GRM033R61C103KA12D
22	C22	CAP, CERM, 1 μ F, 6.3 V, \pm 20%, X5R, 0201	MuRata	GRM033R60J105MEA2D
23	C23	CAP, CERM, 1 μ F, 6.3 V, \pm 20%, X5R, 0201	MuRata	GRM033R60J105MEA2D
24	C24	CAP, CERM, 0.1 μ F, 10 V, \pm 10%, X5R, 0201	Samsung Electro-Mechanics	CL03A104KP3NNNC
25	C25	CAP, CERM, 0.01 μ F, 16 V, \pm 10%, X5R, 0201	MuRata	GRM033R61C103KA12D
26	C26	CAP, CERM, 2.2 μ F, 6.3 V, \pm 20%, X5R, 0201	Samsung Electro-Mechanics	CL03A225MQ3CRNC
27	C27	CAP, CERM, 0.1 μ F, 10 V, \pm 10%, X5R, 0201	Samsung Electro-Mechanics	CL03A104KP3NNNC
28	C28	CAP, CERM, 0.01 μ F, 16 V, \pm 10%, X5R, 0201	MuRata	GRM033R61C103KA12D
29	C29	CAP, CERM, 0.1 μ F, 10 V, \pm 10%, X5R, 0201	Samsung Electro-Mechanics	CL03A104KP3NNNC
30	C30	CAP, CERM, 2.2 μ F, 6.3 V, \pm 20%, X5R, 0201	Samsung Electro-Mechanics	CL03A225MQ3CRNC
31	C31	CAP, CERM, 1 μ F, 6.3 V, \pm 20%, X5R, 0201	MuRata	GRM033R60J105MEA2D
32	C32	CAP, CERM, 0.1 μ F, 25 V, \pm 5%, X7R, 0603	AVX	06033C104JAT2A
33	C33	CAP, CERM, 0.1 μ F, 25 V, \pm 5%, X7R, 0603	AVX	06033C104JAT2A

Table 7-1. Bill of Materials (continued)

Item	Designator	Description	Manufacturer	PartNumber
34	C34	CAP, CERM, 0.1 μ F, 25 V, \pm 5%, X7R, 0603	AVX	06033C104JAT2A
35	C35	CAP, CERM, 0.1 μ F, 25 V, \pm 5%, X7R, 0603	AVX	06033C104JAT2A
36	C36	CAP, CERM, 0.1 μ F, 25 V, \pm 5%, X7R, 0603	AVX	06033C104JAT2A
37	C37	CAP, CERM, 0.1 μ F, 25 V, \pm 5%, X7R, 0603	AVX	06033C104JAT2A
38	D1	DIODE SCHOTTKY 40V 1A PMDU	Rohm	RB168MM-40TR
39	D2	DIODE SCHOTTKY 40V 1A PMDU	Rohm	RB168MM-40TR
40	D3	3V Clamp 9A (8/20 μ s) Ipp Tvs Diode Surface Mount DSN0603-2	Nexperia	PESD5V0C1USF
41	D4	3V Clamp 9A (8/20 μ s) Ipp Tvs Diode Surface Mount DSN0603-2	Nexperia	PESD5V0C1USF
42	D5	3V Clamp 9A (8/20 μ s) Ipp Tvs Diode Surface Mount DSN0603-2	Nexperia	PESD5V0C1USF
43	D6	3V Clamp 9A (8/20 μ s) Ipp Tvs Diode Surface Mount DSN0603-2	Nexperia	PESD5V0C1USF
44	H9	Bumpon, Hemisphere, 0.44 X 0.20, Clear	3M	SJ-5303 (CLEAR)
45	H10	Bumpon, Hemisphere, 0.44 X 0.20, Clear	3M	SJ-5303 (CLEAR)
46	H11	Bumpon, Hemisphere, 0.44 X 0.20, Clear	3M	SJ-5303 (CLEAR)
47	H12	Bumpon, Hemisphere, 0.44 X 0.20, Clear	3M	SJ-5303 (CLEAR)
48	J1	Connector, Receptacle, USB TYPE B, R/A, Top Mount TH	Molex	67068-8000
49	J2	Connector, Receptacle, USB Standard, R/A, Top Mount TH	Molex	676430910
50	J3	Header, 2.54mm, 3x1, Gold, SMT	Molex	87898-0304
51	J4	Header, 2.54mm, 3x1, Gold, SMT	Molex	87898-0304
52	J5	Header, 2.54mm, 3x1, Gold, SMT	Molex	87898-0304
53	J6	Header, 2.54mm, 3x1, Gold, SMT	Molex	87898-0304
54	J7	Header, 2.54mm, 3x1, Gold, SMT	Molex	87898-0304
55	J8	Header, 2.54mm, 3x1, Gold, SMT	Molex	87898-0304
56	J9	Header, 2.54mm, 3x1, Gold, SMT	Molex	87898-0304
57	J10	Header, 2.54mm, 3x1, Gold, SMT	Molex	87898-0304
58	J11	Header, 2.54mm, 3x1, Gold, SMT	Molex	87898-0304
59	J12	Header, 2.54 mm, 2x1, Gold, R/A, SMT	Molex	878980204
60	J13	Connector, Receptacle, USB TYPE B, R/A, Top Mount TH	Molex	67068-8000
61	J14	Connector, Receptacle, USB Standard, R/A, Top Mount TH	Molex	676430910
62	J15	Header, 2.54mm, 3x1, Gold, SMT	Molex	87898-0304
63	L1	Ferrite Bead, 1500 ohm @ 100 MHz, 0.5 A, 0603	MuRata	BLM18HE152SN1D
64	L2	Ferrite Bead, 1500 ohm @ 100 MHz, 0.5 A, 0603	MuRata	BLM18HE152SN1D
65	LBL1	Thermal Transfer Printable Labels, 0.650" W x 0.200" H - 10,000 per roll	Brady	THT-14-423-10
66	R1	RES, 97.6 k, 1%, 0.1 W, AEC-Q200 Grade 0, 0603	Vishay-Dale	CRCW060397K6FKEA
67	R2	RES, 30.1 k, 1%, 0.1 W, AEC-Q200 Grade 0, 0603	Vishay-Dale	CRCW060330K1FKEA
68	R3	RES, 53.6 k, 1%, 0.1 W, AEC-Q200 Grade 0, 0603	Vishay-Dale	CRCW060353K6FKEA
69	R4	RES, 30.1 k, 1%, 0.1 W, AEC-Q200 Grade 0, 0603	Vishay-Dale	CRCW060330K1FKEA
70	R5	RES, 15.0 k, 1%, 0.1 W, AEC-Q200 Grade 0, 0603	Vishay-Dale	CRCW060315K0FKEA

Table 7-1. Bill of Materials (continued)

Item	Designator	Description	Manufacturer	PartNumber
71	R6	RES, 30.1 k, 1%, 0.1 W, AEC-Q200 Grade 0, 0603	Vishay-Dale	CRCW060330K1FKEA
72	R7	RES, 53.6 k, 1%, 0.1 W, AEC-Q200 Grade 0, 0603	Vishay-Dale	CRCW060353K6FKEA
73	R8	RES, 30.1 k, 1%, 0.1 W, AEC-Q200 Grade 0, 0603	Vishay-Dale	CRCW060330K1FKEA
74	R9	RES, 15.0 k, 1%, 0.1 W, AEC-Q200 Grade 0, 0603	Vishay-Dale	CRCW060315K0FKEA
75	R10	RES, 30.1 k, 1%, 0.1 W, AEC-Q200 Grade 0, 0603	Vishay-Dale	CRCW060330K1FKEA
76	R11	RES, 0, 5%, 0.1 W, AEC-Q200 Grade 0, 0603	Vishay-Dale	CRCW06030000Z0EA
77	R12	RES, 0, 5%, 0.1 W, AEC-Q200 Grade 0, 0603	Vishay-Dale	CRCW06030000Z0EA
78	R13	RES, 0, 1%, 0.5 W, 0805	Keystone	5106
79	R14	RES, 0, 1%, 0.5 W, 0805	Keystone	5106
80	R15	RES, 0, 1%, 0.5 W, 0805	Keystone	5106
81	R16	RES, 0, 5%, 0.1 W, AEC-Q200 Grade 0, 0603	Vishay-Dale	CRCW06030000Z0EA
82	R17	RES, 0, 5%, 0.1 W, AEC-Q200 Grade 0, 0603	Vishay-Dale	CRCW06030000Z0EA
83	R18	RES, 0, 1%, 0.5 W, 0805	Keystone	5106
84	R19	RES, 0, 1%, 0.5 W, 0805	Keystone	5106
85	R20	RES, 0, 1%, 0.5 W, 0805	Keystone	5106
86	R21	RES, 0, 5%, 0.1 W, AEC-Q200 Grade 0, 0603	Vishay-Dale	CRCW06030000Z0EA
87	R22	RES, 0, 5%, 0.1 W, AEC-Q200 Grade 0, 0603	Vishay-Dale	CRCW06030000Z0EA
88	R23	RES, 0, 1%, 0.5 W, 0805	Keystone	5106
89	R24	RES, 0, 1%, 0.5 W, 0805	Keystone	5106
90	R25	RES, 0, 1%, 0.5 W, 0805	Keystone	5106
91	R26	RES, 0, 5%, 0.1 W, AEC-Q200 Grade 0, 0603	Vishay-Dale	CRCW06030000Z0EA
92	R27	RES, 0, 5%, 0.1 W, AEC-Q200 Grade 0, 0603	Vishay-Dale	CRCW06030000Z0EA
93	R28	RES, 0, 1%, 0.5 W, 0805	Keystone	5106
94	R29	RES, 0, 1%, 0.5 W, 0805	Keystone	5106
95	R30	RES, 0, 1%, 0.5 W, 0805	Keystone	5106
96	R31	RES, 2.40 k, 0.1%, 0.1 W, 0603	Susumu Co Ltd	RG1608P-242-B-T5
97	R32	RES, 2.40 k, 0.1%, 0.1 W, 0603	Susumu Co Ltd	RG1608P-242-B-T5
98	R33	RES, 2.40 k, 0.1%, 0.1 W, 0603	Susumu Co Ltd	RG1608P-242-B-T5
99	R34	RES, 2.40 k, 0.1%, 0.1 W, 0603	Susumu Co Ltd	RG1608P-242-B-T5
100	R35	RES, 4.70 k, 0.1%, 0.1 W, 0603	Yageo America	RT0603BRD074K7L
101	T1	Transformer, 110 uH, SMT	Würth Elektronik	750315240
102	TP1	Test Point, Red, Through Hole, RoHS, Bulk	Keystone	5011
103	TP2	Test Point, Multipurpose, Black, TH	Keystone	5011
104	TP3	Test Point, Red, Through Hole, RoHS, Bulk	Keystone	5011
105	TP4	Test Point, Multipurpose, Black, TH	Keystone	5011
106	TP5	Test Point, Red, Through Hole, RoHS, Bulk	Keystone	5011
107	TP6	Test Point, Multipurpose, Black, TH	Keystone	5011
108	TP7	Test Point, Red, Through Hole, RoHS, Bulk	Keystone	5011
109	TP8	Test Point, Red, Through Hole, RoHS, Bulk	Keystone	5011
110	TP9	Test Point, Red, Through Hole, RoHS, Bulk	Keystone	5011
111	TP10	Test Point, Red, Through Hole, RoHS, Bulk	Keystone	5011
112	TP11	Test Point, Red, Through Hole, RoHS, Bulk	Keystone	5011
113	TP12	Test Point, Multipurpose, Black, TH	Keystone	5011

Table 7-1. Bill of Materials (continued)

Item	Designator	Description	Manufacturer	PartNumber
114	TP13	Test Point, Red, Through Hole, RoHS, Bulk	Keystone	5011
115	TP14	Test Point, Red, Through Hole, RoHS, Bulk	Keystone	5011
116	TP15	Test Point, Red, Through Hole, RoHS, Bulk	Keystone	5011
117	TP16	Test Point, Red, Through Hole, RoHS, Bulk	Keystone	5011
118	TP17	Test Point, Red, Through Hole, RoHS, Bulk	Keystone	5011
119	TP18	Test Point, Multipurpose, Black, TH	Keystone	5011
120	U1	High/Full/Low Speed Isolated USB Repeater, SSOP28	Texas Instruments	ISOUSB211DP
121	U2	Low-Noise 1-A Transformer Driver for Isolated Power Supplies, Internal Clock-160kHz, DBV0006A (SOT-23-6)	Texas Instruments	SN6505ADBVR
122	U3	Single Output LDO, 1A, Adj. (1.2 to 5.0V), Reverse Current Protection, DRB0008A (VSON-8)	Texas Instruments	TPS73701DRBT
123	U4	Single Output Fast Transient Response LDO, 1 A, Adjustable 1.5 to 5.5 V Output, 2.7 to 10 V Input, with Low IQ, 8-pin SOIC (D), -40 to 125 degC, Green (RoHS & no Sb/Br)	Texas Instruments	TPS76701QD
124	U5	Single Output Fast Transient Response LDO, 1 A, Adjustable 1.5 to 5.5 V Output, 2.7 to 10 V Input, with Low IQ, 8-pin SOIC (D), -40 to 125 degC, Green (RoHS & no Sb/Br)	Texas Instruments	TPS76701QD
125	U6	Single Output Fast Transient Response LDO, 1 A, Adjustable 1.5 to 5.5 V Output, 2.7 to 10 V Input, with Low IQ, 8-pin SOIC (D), -40 to 125 degC, Green (RoHS & no Sb/Br)	Texas Instruments	TPS76701QD
126	U7	Single Output Fast Transient Response LDO, 1 A, Adjustable 1.5 to 5.5 V Output, 2.7 to 10 V Input, with Low IQ, 8-pin SOIC (D), -40 to 125 degC, Green (RoHS & no Sb/Br)	Texas Instruments	TPS76701QD
127	U8	Dual-Channel High-Speed ESD Protection, DRL0005A (SOT-OTHER-5)	Texas Instruments	TPD2E2U06DRLR
128	U9	Dual-Channel High-Speed ESD Protection, DRL0005A (SOT-OTHER-5)	Texas Instruments	TPD2E2U06DRLR

IMPORTANT NOTICE AND DISCLAIMER

TI PROVIDES TECHNICAL AND RELIABILITY DATA (INCLUDING DATA SHEETS), DESIGN RESOURCES (INCLUDING REFERENCE DESIGNS), APPLICATION OR OTHER DESIGN ADVICE, WEB TOOLS, SAFETY INFORMATION, AND OTHER RESOURCES "AS IS" AND WITH ALL FAULTS, AND DISCLAIMS ALL WARRANTIES, EXPRESS AND IMPLIED, INCLUDING WITHOUT LIMITATION ANY IMPLIED WARRANTIES OF MERCHANTABILITY, FITNESS FOR A PARTICULAR PURPOSE OR NON-INFRINGEMENT OF THIRD PARTY INTELLECTUAL PROPERTY RIGHTS.

These resources are intended for skilled developers designing with TI products. You are solely responsible for (1) selecting the appropriate TI products for your application, (2) designing, validating and testing your application, and (3) ensuring your application meets applicable standards, and any other safety, security, regulatory or other requirements.

These resources are subject to change without notice. TI grants you permission to use these resources only for development of an application that uses the TI products described in the resource. Other reproduction and display of these resources is prohibited. No license is granted to any other TI intellectual property right or to any third party intellectual property right. TI disclaims responsibility for, and you will fully indemnify TI and its representatives against, any claims, damages, costs, losses, and liabilities arising out of your use of these resources.

TI's products are provided subject to [TI's Terms of Sale](#) or other applicable terms available either on ti.com or provided in conjunction with such TI products. TI's provision of these resources does not expand or otherwise alter TI's applicable warranties or warranty disclaimers for TI products.

TI objects to and rejects any additional or different terms you may have proposed.

Mailing Address: Texas Instruments, Post Office Box 655303, Dallas, Texas 75265
Copyright © 2022, Texas Instruments Incorporated

X-ON Electronics

Largest Supplier of Electrical and Electronic Components

Click to view similar products for [Interface Development Tools](#) *category:*

Click to view products by [Texas Instruments](#) *manufacturer:*

Other Similar products are found below :

[CY4607M](#) [XR17V358/SP339-E8-EB](#) [TW-DONGLE-USB](#) [XR21B1424IV64-0A-EVB](#) [P0551](#) [5346](#) [SI32185ACB10SL1KIT](#)
[RAA2S4252EXT](#) [4901](#) [DFR0979](#) [LIME2-SHIELD](#) [EM01-D](#) [ISOUSB211DPEVM](#) [USB TO TTL](#) [USB TO RS485](#) [PL2303](#) [USB UART](#)
[Board \(type A\) V2](#) [USB-CAN-A](#) [103030295](#) [MIKROE-2335](#) [KIT_MINIWIGGLER_3_USB](#) [KITXMC4XCOMETH001TOBO1](#)
[SI871XSOIC8-KIT](#) [1764](#) [1833](#) [1862](#) [ZSC31010KITV2.1](#) [EVB-USB82514](#) [ATAB663231A-V1.2](#) [ATAB663254A-V1.2](#) [2264](#)
[MCP23X17EV](#) [PS09-EVA-KIT](#) [237](#) [SMA2RJ45EVB/NOPB](#) [FR12-0002](#) [MAFR-000667-000001](#) [MAFR-000589-000001](#) [MAFR-000553-](#)
[000001](#) [BOB-13263](#) [BP359C](#) [ORG4572-R01-UAR](#) [XR21B1422IL40-0A-EVB](#) [SKYFR-000743](#) [SKYFR-000827](#) [SKYFR-000982](#) [MIKROE-](#)
[2750](#) [292](#) [DEMOBOARDIFX1050GTOBO1](#) [CY4521](#) [HDMI-VIP-IB-EVN](#)