

适用于 1ns 脉宽应用的 LMG1020 5V 7A/5A 低侧 GaN 和 MOSFET 驱动器

1 特性

- 用于 GaN 和硅质 FET 的低侧、超快栅极驱动器
- 1ns 最小输入脉冲宽度
- 工作频率高达 60MHz
- 传播延迟：典型值 2.5ns，最大值 4.5ns
- 典型上升和下降时间 400ps
- 7A 峰值拉电流和 5A 峰值灌电流
- 5V 电源电压
- UVLO 和过热保护
- 0.8mm × 1.2mm WCSP 封装

2 应用

- 激光雷达
- 飞行时间激光驱动器
- 面部识别
- E 类无线充电器
- VHF 谐振电源转换器
- 基于 GaN 的同步整流器
- 扩增实境

3 说明

LMG1020 器件是一款单通道低侧驱动器，专为在高速应用（包括 LiDAR、飞行时间、面部识别和任何涉及低侧驱动器的功率转换器）中驱动 GaN FET 和逻辑电平 MOSFET 而设计。LMG1020 设计简约，可实现 2.5 纳秒的极快传播延迟和 1 纳秒的最小脉冲宽度。通过分别在栅极与 OUTH 和 OUTL 之间连接外部电阻器，可针对上拉和下拉沿来独立调节驱动强度。

该驱动器提供过载或故障情况下的欠压锁定 (UVLO) 和过热保护 (OTP)。

LMG1020 的 0.8mm × 1.2mm WCSP 封装可最大限度地降低栅极回路电感并最大限度地提高高频功率密度要求。

器件信息⁽¹⁾

器件型号	封装	封装尺寸 (标称值)
LMG1020	WCSP (6)	0.80mm × 1.20mm

(1) 如需了解所有可用封装，请参阅数据表末尾的可订购产品附录。

简化的激光雷达 (LiDAR) 驱动器级图

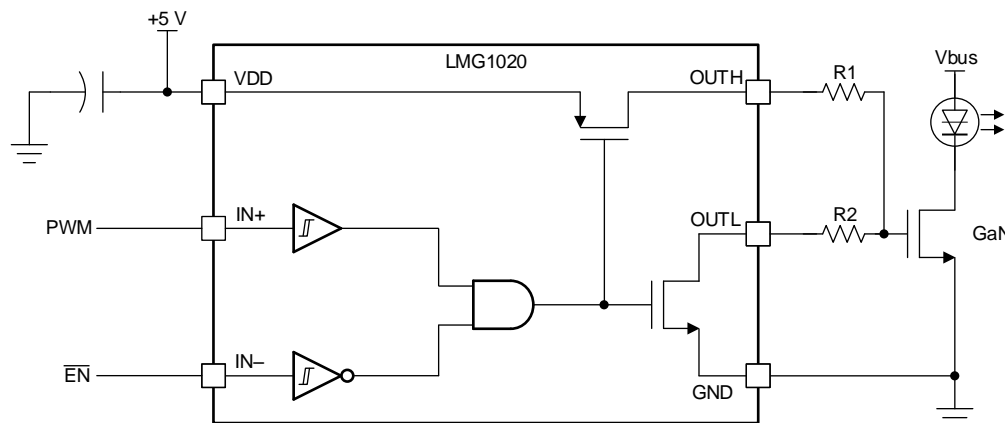

目录

<p>1 特性 1</p> <p>2 应用 1</p> <p>3 说明 1</p> <p>4 修订历史记录 2</p> <p>5 Pin Configuration and Functions 3</p> <p>6 Specifications 4</p> <p> 6.1 Absolute Maximum Ratings 4</p> <p> 6.2 ESD Ratings 4</p> <p> 6.3 Recommended Operating Conditions 4</p> <p> 6.4 Thermal Information 4</p> <p> 6.5 Electrical Characteristics 5</p> <p> 6.6 Switching Characteristics 6</p> <p> 6.7 Typical Characteristics 7</p> <p>7 Detailed Description 8</p> <p> 7.1 Overview 8</p> <p> 7.2 Functional Block Diagram 8</p> <p> 7.3 Feature Description 8</p>	<p>7.4 Device Functional Modes 9</p> <p>8 Application and Implementation 10</p> <p> 8.1 Application Information 10</p> <p> 8.2 Typical Application 10</p> <p>9 Power Supply Recommendations 15</p> <p>10 Layout 16</p> <p> 10.1 Layout Guidelines 16</p> <p> 10.2 Layout Example 16</p> <p>11 器件和文档支持 18</p> <p> 11.1 文档支持 18</p> <p> 11.2 接收文档更新通知 18</p> <p> 11.3 社区资源 18</p> <p> 11.4 商标 18</p> <p> 11.5 静电放电警告 18</p> <p> 11.6 术语表 18</p> <p>12 机械、封装和可订购信息 18</p>
--	---

4 修订历史记录

Changes from Original (June 2018) to Revision B

Page

<ul style="list-style-type: none"> • 已更改 将图 1 输入结构中的“与非门”更改为“与门” 1 	1
---	---

5 Pin Configuration and Functions

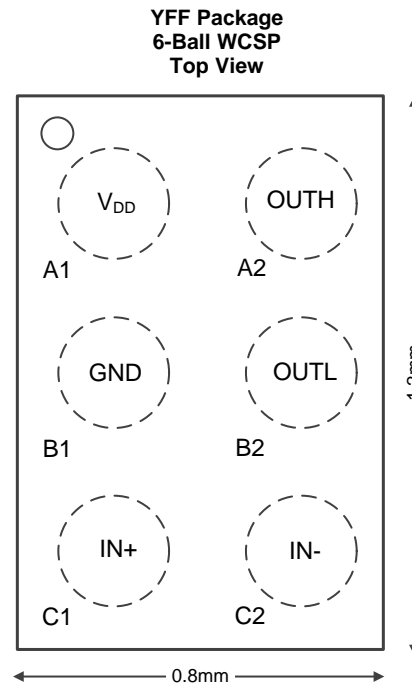

Pin Functions

PIN		I/O	DESCRIPTION
NAME	NO.		
GND	B1	—	Ground
IN+	C1	I	Positive logic-level input
IN-	C2	I	Negative logic-level input
OUTL	B2	O	Pulldown gate drive output. Connect through an optional resistor to the target transistor's gate
OUTH	A2	O	Pullup gate drive output. Connect through a resistor to the target transistor's gate
VDD	A1	I	Input voltage supply. Decouple through a small size, low inductance capacitor to GND

6 Specifications

6.1 Absolute Maximum Ratings

over operating free-air temperature range (unless otherwise noted)⁽¹⁾

		MIN	MAX	UNIT
V _{DD}	Supply voltage		5.75	V
V _{IN}	IN+, IN- pin voltage	-0.3	V _{DD} + 0.3	V
V _{OUT}	OUTH, OUTL pin voltage	-0.3	5.75	V
T _{STG}	Storage Temperature	-55	150	°C
T _J	Operating Temperature	-40	150	°C

- (1) Stresses beyond those listed under *Absolute Maximum Rating* may cause permanent damage to the device. These are stress ratings only, which do not imply functional operation of the device at these or any other conditions beyond those indicated under *Recommended Operating Condition*. Exposure to absolute-maximum-rated conditions for extended periods may affect device reliability.

6.2 ESD Ratings

		VALUE	UNIT
V _(ESD)	Electrostatic discharge	Human body model (HBM), per ANSI/ESDA/JEDEC JS-001, all pins ⁽¹⁾	±2000
		Charged device model (CDM), per JEDEC specification JESD22-C101, all pins ⁽²⁾	±500

- (1) JEDEC document JEP155 states that 500-V HBM allows safe manufacturing with a standard ESD control process. Manufacturing with less than 500-V HBM is possible with the necessary precautions.
 (2) JEDEC document JEP157 states that 250-V CDM allows safe manufacturing with a standard ESD control process. Manufacturing with less than 250-V CDM is possible with the necessary precautions.

6.3 Recommended Operating Conditions

over operating free-air temperature range (unless otherwise noted)

		MIN	NOM	MAX	UNIT
V _{DD}	Supply voltage	4.75	5	5.4	V
V _{INx}	IN+ or IN- input voltage	0		V _{DD}	V
T _J	Operating Temperature	-40		125	°C

6.4 Thermal Information

THERMAL METRIC ⁽¹⁾		SN1020	UNIT
		YFF (WCSP)	
		6 PINS	
R _{θJA}	Junction-to-ambient thermal resistance	133.6	°C/W
R _{θJC(top)}	Junction-to-case (top) thermal resistance	1.7	°C/W
R _{θJB}	Junction-to-board thermal resistance	38.1	°C/W
Ψ _{JT}	Junction-to-top characterization parameter	0.5	°C/W
Y _{JB}	Junction-to-board characterization parameter	38.3	°C/W

- (1) For more information about traditional and new thermal metrics, see the [Semiconductor and IC Package Thermal Metrics](#) application report.

6.5 Electrical Characteristics

over operating free-air temperature range (VDD=5V unless otherwise noted)

PARAMETER		TEST CONDITIONS	MIN	TYP	MAX	UNIT
DC Characteristics						
$I_{VDD, Q}$	VDD Quiescent Current	$IN_+ = IN_- = 0\text{ V}$			75	μA
$I_{VDD, op}$	VDD Operating Current ⁽¹⁾	fsw = 30 MHz, 2 Ω , 0.1 pF load		40		mA
		fsw = 30 MHz, 2 Ω , 100 pF load		51		mA
$V_{DD, UVLO}$	Under-voltage Lockout	V_{DD} rising	4.06	4.19	4.33	V
$\Delta V_{DD, UVLO}$	UVLO Hysteresis			85		mV
T_{OTP}	Over temperature shutdown, rising edge threshold			170		$^{\circ}\text{C}$
ΔT_{OTP}	Over temperature hysteresis			18		$^{\circ}\text{C}$
Input DC Characteristics						
V_{IH}	IN_+ , IN_- high threshold		1.7		2.6	V
V_{IL}	IN_+ , IN_- low threshold		1.1		1.8	V
V_{HYST}	IN_+ , IN_- hysteresis		0.5		1	V
R_{IN+}	Positive input pull-down resistance	To GND	100	150	250	$\text{k}\Omega$
R_{IN-}	Negative input pull-up resistance	to V_{DD}	100	150	250	$\text{k}\Omega$
C_{IN}	Input pin capacitance ⁽¹⁾	To GND		1.3		pF
Output DC Characteristics						
V_{OL}	OUTL voltage	$I_{OUTL} = 100\text{ mA}$, $IN_+ = IN_- = 0\text{ V}$			36	mV
$V_{DD} - V_{OH}$	OUTH voltage	$I_{OUTH} = 100\text{ mA}$, $IN_+ = 5\text{ V}$, $IN_- = 0\text{ V}$			50	mV
I_{OH}	Peak source current ⁽¹⁾	$V_{OUTH} = 0\text{ V}$, $IN_+ = 5\text{ V}$, $IN_- = 0\text{ V}$		7		A
I_{OL}	Peak sink current ⁽¹⁾	$V_{OUTL} = 5\text{ V}$, $IN_+ = IN_- = 0\text{ V}$		5		A

(1) Insured by design

6.6 Switching Characteristics

over operating free-air temperature range ($V_{DD}=5V$ unless otherwise noted)

PARAMETER		TEST CONDITIONS	MIN	TYP	MAX	UNIT
t_{start}	Startup Time, V_{DD} rising above UVLO	IN- = GND, IN+ = V_{DD} , V_{DD} rising to 4.2V to OUTH rising		40	70	μs
$t_{shut-off}$	ULVO falling	IN- = GND, IN+ = V_{DD} , V_{DD} falling below 4.1V to OUTH falling	1	1.9	3.1	μs
$t_{pd, r}$	Propagation delay, turn on	IN- = 0 V, IN+ to OUTH, 100 pF load	1.5	2.5	4.1	ns
$t_{pd, f}$	Propagation delay, turn off	IN- = 0 V, IN+ to OUTL, 100 pF load	1.8	2.6	4.3	ns
Δt_{pd}	Pulse positive distortion ($t_{pd, f} - t_{pd, r}$)			230	603	ps
t_{rise}	Output rise time	0 Ω series 100 pF load ⁽¹⁾		375		ps
t_{fall}	Output fall time	0 Ω series 100 pF load ⁽¹⁾		350		ps
t_{min}	Minimum input pulse width	0 Ω series 100 pF load ⁽¹⁾		1		ns

(1) rise and fall calculated as a 20% to 80%

6.7 Typical Characteristics



图 1. $I_{VDD,op}$ vs Frequency With 2 Ω Series 100 pF Load



图 2. $I_{VDD,op}$ vs Temperature At 30MHz With 2 Ω series 100 pF Load

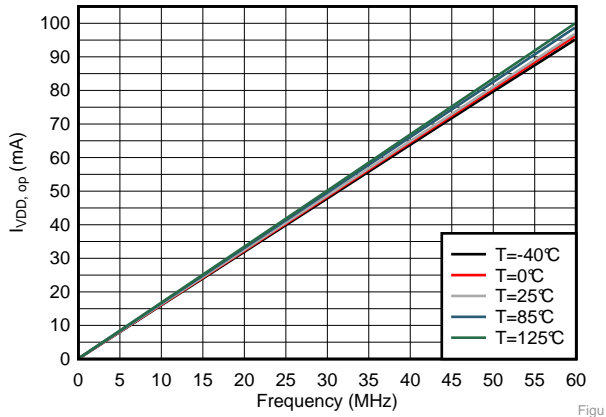

图 3. Quiescent Current vs Temperature

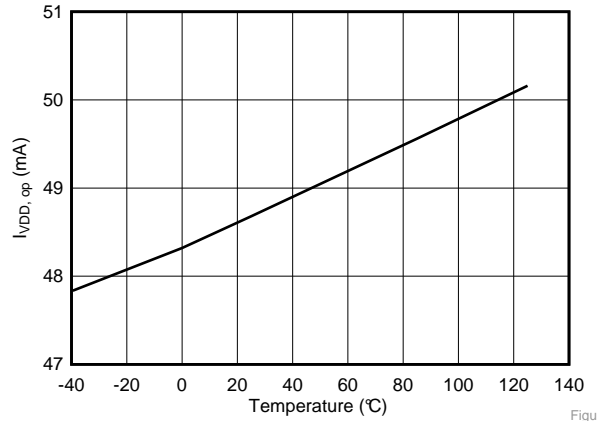

图 4. Propagation Delay vs Temperature

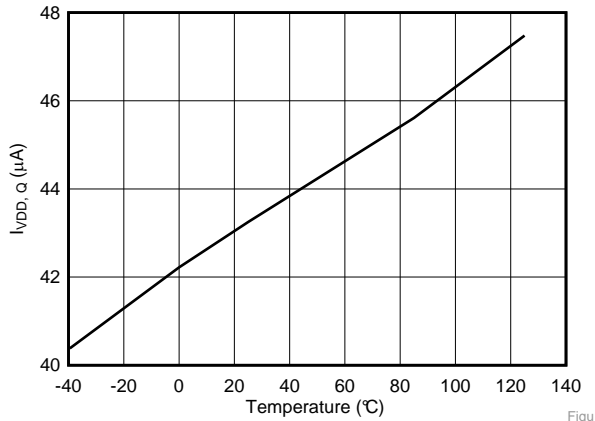

图 5. Rise And Fall Time vs Temperature With 0 Ω Series 100 pF Load

7 Detailed Description

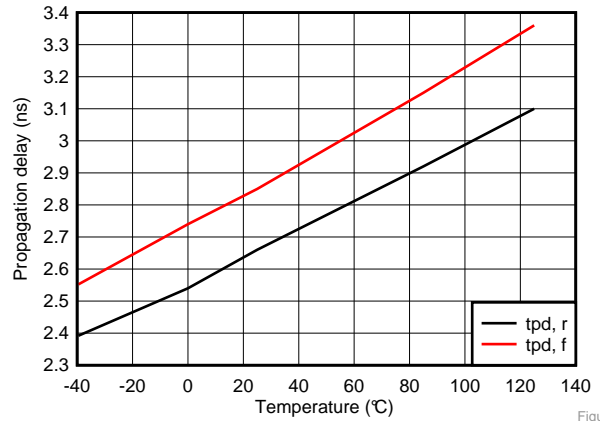
7.1 Overview

LMG1020 is a high-performance low-side 5-V gate driver for GaN and logic-level silicon power transistors. While the LMG1020 is designed for high-speed applications, such as wireless power transmission and LiDAR applications, it is a high-performance solution for any other low-side driving applications.

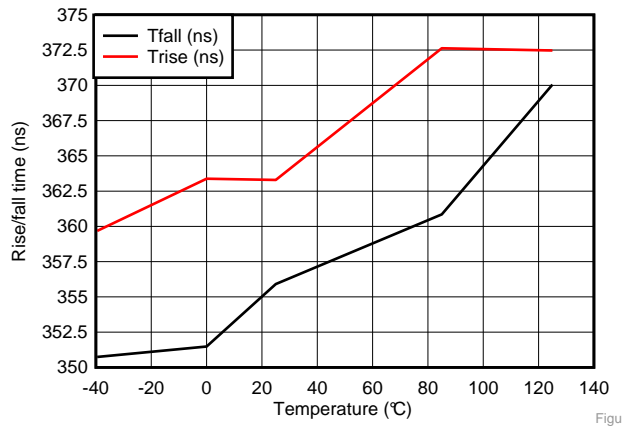
The LMG1020 is optimized to provide the lowest propagation delay through the driver to the power transistor. LMG1020 is in a small 0.8×1.2mm WCSP ball-grid array package in order to minimize its parasitic inductance. This low inductance design helps achieve high current, low ringing performance in very high frequency operation when driving power FETs.

7.2 Functional Block Diagram

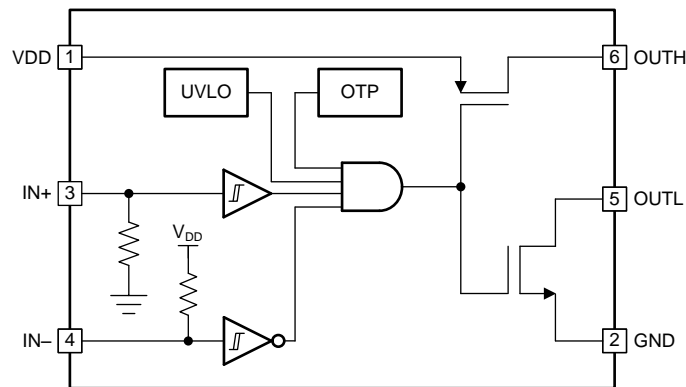

7.3 Feature Description

7.3.1 Input Stage

The input stage features two Schmitt-triggers at the pins IN+ and IN– to reduce sensitivity to noise on the inputs. IN+ signal and the inverted IN– signal are both sent to an AND gate. IN+ is connected with a pull-down resistor while IN– is connected with a pull-up resistor to prevent unintended turnon. The output signal will follow the difference between IN+ and IN–. Both IN+ and IN– are single ended inputs, and these two pins cannot be used as a differential input pair.

7.3.2 Output Stage

LMG1020 provides 7-A source, 5-A sink (asymmetrical drive) peak-drive current capability, and features a split output configuration. The OUTH and OUTL outputs of the LMG1020 allow the user to use independent resistors connecting to the gate. The two resistors allow the user to independently adjust the turnon and turnoff drive strengths to control slew rate and EMI, and to control ringing on the gate signal. For GaN FETs, controlling ringing is important to reduce stress on the GaN FET and driver. The output stage OUTL is also pulled down in undervoltage condition, which prevents the unintended charge accumulation of device C_{iss} .

7.3.3 V_{DD} and undervoltage lockout

LMG1020 features nominal 5V and maximum 5.25V of supply voltage, and its absolute maximum supply voltage is 5.75 V. In the design, it is recommended to limit the variability of the power supply to be within 5% (0.25V), and the overshoot voltage during switching transient not to exceed the absolute maximum voltage. Refer to Section [VDD and Overshoot](#) for more the detailed design guide.

LMG1020 also features internal undervoltage lockout (UVLO) to protect the driver and circuit in case of fault conditions. The UVLO point is setup between 4.1V and 4.2V with a hysteresis of 85mV. This UVLO level is specifically designed to guarantee that GaN power devices can be switched at a low $R_{DS(ON)}$ region. During UVLO condition, the OUTL is pulled down to ground.

Feature Description (接下页)

7.3.4 Overtemperature Protection (OTP)

LMG1020 features overtemperature protection (OTP) function by having a rising edge trigger point at around 170°C. With a hysteresis of 20°C, the device can restart to operate when junction temperature is below 150°C.

7.4 Device Functional Modes

表 1. Truth Table

IN-	IN+	OUTH	OUTL
L	L	OPEN	L
L	H	H	OPEN
H	L	OPEN	L
H	H	OPEN	L

8 Application and Implementation

注

Information in the following applications sections is not part of the TI component specification, and TI does not warrant its accuracy or completeness. TI's customers are responsible for determining suitability of components for their purposes. Customers should validate and test their design implementation to confirm system functionality.

8.1 Application Information

To operate GaN transistors at very high switching frequencies and to reduce associated switching losses, a powerful gate driver is employed between the PWM output of controller and the gates of the GaN transistor. Also, gate drivers are indispensable when the outputs of the PWM controller do not meet the voltage or current levels needed to directly drive the gates of the switching devices. With the advent of digital power, this situation is often encountered because the PWM signal from the digital controller is often a 3.3 V logic signal, which cannot effectively turn on a power switch. A level-shift circuit is needed to boost the 3.3 V signal to the gate-drive voltage (such as 5 V) in order to fully turn on the power device and minimize conduction losses.

Gate drivers effectively provide the buffer-drive functions. Gate drivers also address other needs such as minimizing the effect of high-frequency switching noise (by placing the high-current driver IC physically close to the power switch), reducing power dissipation and thermal stress in controllers by moving gate charge power losses from the controller into the driver.

The LMG1020 is a 60-MHz low-side gate driver for enhancement mode GaN FETs and Si FETs in a single-ended configuration. The split-gate outputs with strong source and sink capability provides flexibility to adjust the turnon and turnoff strength independently. As a low side driver, LMG1020 can be used in a variety of applications, including different power converters, LiDAR, time-of-flight laser drivers, class-E wireless chargers, synchronous rectifiers, and augmented reality. LMG1020 can also be used as a high frequency low current laser diode driver, or as a signal buffer with very fast rise/fall time.

8.2 Typical Application

The LMG1020 is designed to be used with a single low-side, ground-referenced GaN or logic-level Si FET, as shown in [图 6](#). Independent gate drive resistors, R1 and R2, are used to independently control the turnon and turnoff drive strengths, respectively. For fast and strong turnoff, R2 can be shorted and OUTL directly connected to the transistor's gate. For symmetric drive strengths, it is acceptable to short OUTH and OUTL and use a single gate-drive resistor.

TI recommends using at least a 2 Ω resistor at each OUTH and OUTL to avoid voltage overstress due to inductive ringing. Ringing overshoot must not exceed the maximum absolute supply voltage.

For applications requiring smaller resistance values, contact TI E2E for guidance.



图 6. Typical Implementation of a Circuit

Typical Application (接下页)

8.2.1 Design Requirements

When designing a multi-MHz (or nano-second pulse) application that incorporates the LMG1020 gate driver and GaN power FETs, some design considerations must be evaluated first to make the most appropriate selection. Among these considerations are layout optimization, circuit voltages, passive components, operating frequency, and controller selection.

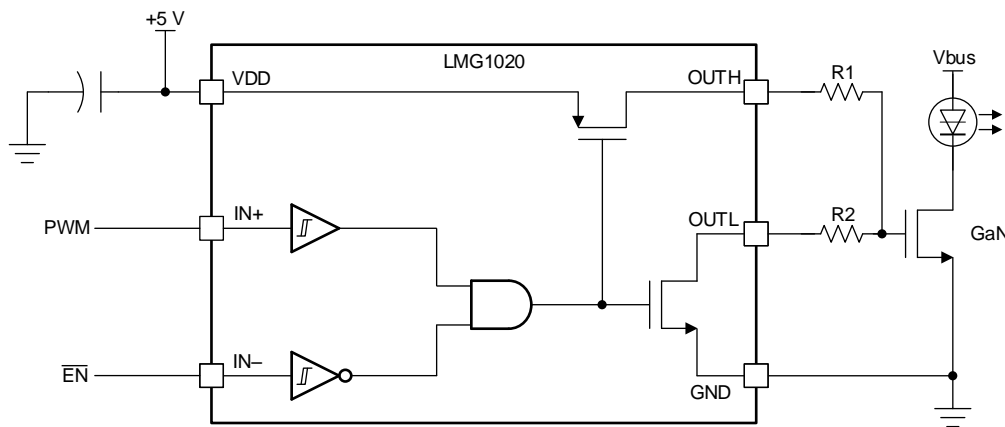
8.2.2 Detailed Design Procedure

8.2.2.1 Handling Ground Bounce

For the best switching performance and gate loop with lowest parasitics, it is recommended to connect the ground return pin of LMG1020 as close as possible to the source of the low-side FET in a low inductance manner. However, doing so can cause the ground of LMG1020 to bounce relative to the system or controller ground and lead to erroneous switching logic on the input so as mis-turn on/off on the output.

First of all, LMG1020 has input hysteresis built into the input buffers to help counteract this effect. The maximum di/dt allowed to prevent the input voltage transient from exceeding the input hysteresis is given by [公式 1](#)

$$\frac{di_s}{dt} = \frac{V_{HYST}}{L_{RS}}$$

where

- L_{RS} is the inductance between FET source and ground,
- V_{HYST} is the hysteresis of the input pin,
- and $di_s/\Delta t$ is the maximum allowed current slew rate. (1)

For an assumed parasitic inductance of 0.5 nH and a minimum hysteresis of 0.5 V, the maximum slew rate is 1 A/ns. Many applications would exhibit higher current slew rates, up to the 10 A/ns range, which would make this approach impractical. The stability of this approach can be improved by using the IN– input for the PWM signal and locally tying IN+ to VDD. By using the inverting input, the transient voltage applied to the input pin reinforces the PWM signal in a positive feedback loop. While this approach would reduce the probability of false pulses or oscillation, the transient spikes due to high di/dt may overly stress the inputs to the LMG1020. A current-limiting, 100 Ω resistor can be placed right before the IN– input to limit excessive current spikes in the device.

Secondly, for moderate ground-bounce cases, a simple R-C filter can be built with a simple resistor in series with the inputs. By utilizing the input capacitance of LMG1020, the resistor could be close to its input pin. The addition of a small capacitor on the input as supplement can also be helpful. A small time constant of the R-C filter can be enough to filter out high frequency noises. This solution is acceptable for moderate cases in applications where extra delay is acceptable and the pulse width is not extremely short such as 1ns range.

For more extreme cases, or where no delay is tolerable while pulse width is extremely short, using a common-mode choke provides the best results.

One example application where ground-bounce is particularly challenging is when using a current sense resistor. In configuration A LMG1020 ground is connected to the source of GaN FET, while the controller ground is connected to the other side of the current sense resistor as shown in [图 7](#). Due to the fast switching and very fast current slew rates, the high ground potential bounce induced by inductance of the sense resistor can disrupt the operation of the circuit or even damage the part. To prevent this, a common-mode choke can be used for IN+ and IN–, respectively. Resistors can also be added to the signal output line before LMG1020 depending on the input signal pulse width to provide additional RC filtering. [图 9](#) presents the schematic using approach A with the preferred filtering method. Approach B as [图 8](#) places the current sense resistor within the gate drive loop path. In this case, the LMG1020 GND pin is connected to the signal ground, and with good ground plane connection, the ground bounce issue can be less severe than approach A. However, the inductance of the current sense resistor adds common-source inductance to the gate drive loop. The voltage generated across this parasitic inductance will subtract from the gate-drive voltage of the FET, slowing down the turnon and turnoff di/dt of the FET, or even cause mis-turn on and off. Additional gate resistance will have to be added to ensure the loop is stable and ring-free. The slower rise may negate the advantage of the fast switching of the GaN FET and may cause additional losses in the circuit. Therefore, this approach is not recommended.

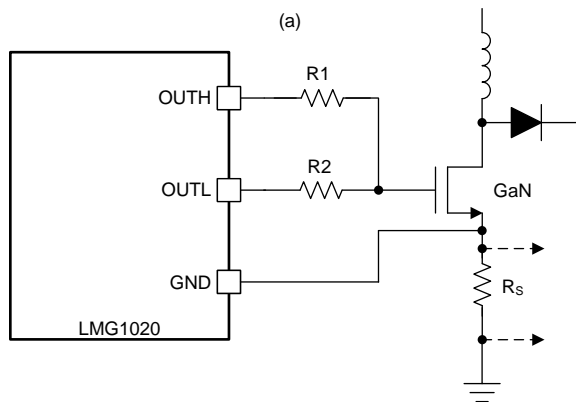
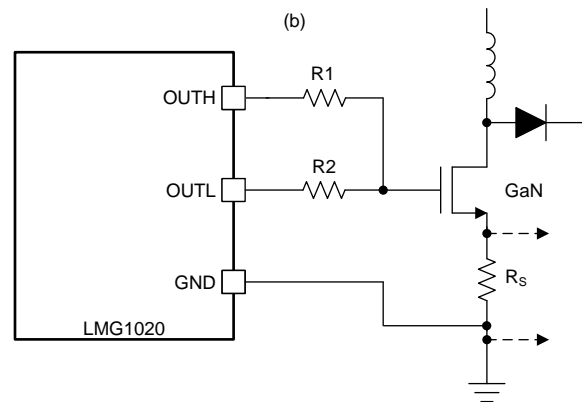
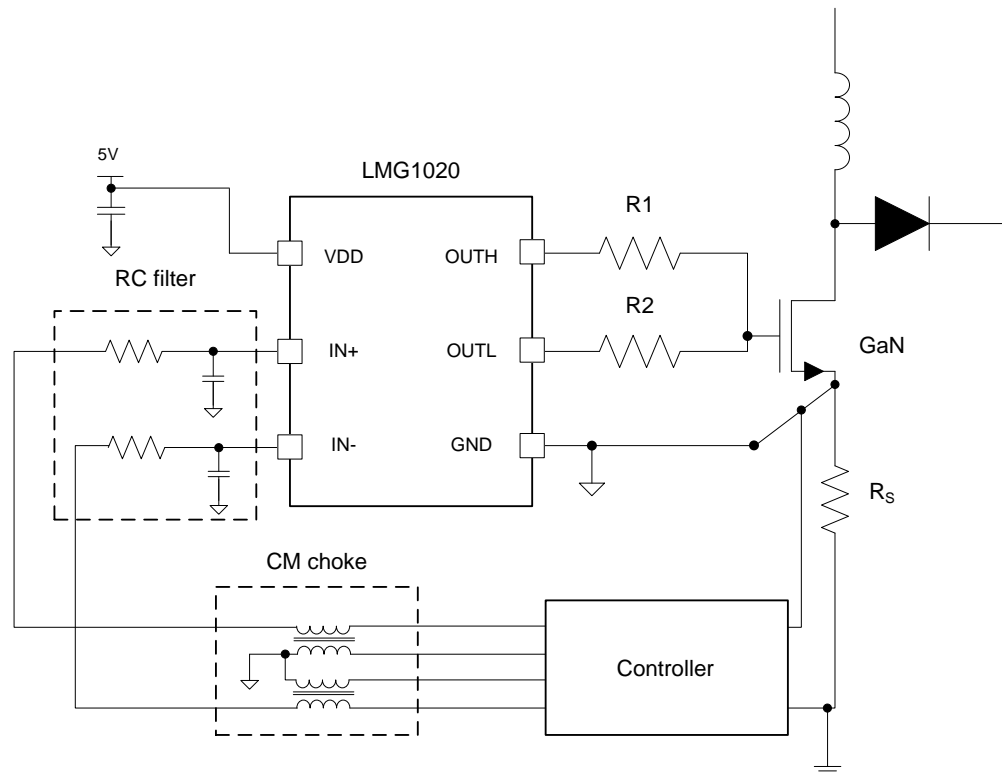
Typical Application (接下页)

图 7. Source Resistor Current Sense A Configuration

图 8. Source Resistor Current Sense B Configuration

图 9. Filtering For Ground Bounce Noise Handling When Using LMG1020
8.2.2.2 Creating Nanosecond Pulse With LMG1020

LMG1020 can be used to drive pulses of nano seconds duration on to a capacitive load. LMG1020 can be driven with a equivalently short pulse on one input pin. However, this takes a sufficiently strong digital driver and careful consideration of the routing parasitics from digital output to input of LMG1020. Two inputs and included AND gate in LMG1020 provide an alternate method to create a short pulse at the LMG1020 output. Starting with both IN+ and IN- at low, taking IN+ high will cause the output to go high. Now if IN- is taken high as well, output will be pulled low. So a digital signal and its delayed version can be applied to IN+ and IN- respectively to create a

Typical Application (接下页)

pulse at the output with width corresponding to the delay between the signals, as shown in 图 10. The delay can be digitally controlled in the nanosecond range. This method alleviates the requirements for driving the input of LMG1020. If a separate delayed version of the digital signal is not available, a RC delay followed by a buffer can be used to derive the second signal. Optionally, if LMG1020 must be driven with a single short duration pulse, that pulse can itself be generated using another LMG1020 by the above method to meet drive requirements.



图 10. Timing Diagram To Create Short Pulses

8.2.3 VDD and Overshoot

Fast switching with high current is prone to ringing with parasitic inductances, including those on PCB traces. Overshoot associated with such ringing transients need to be evaluated and controlled as a part of the PCB design process to limit device stress. The parameters affecting stress are how high the overshoot is above the absolute maximum specification and the ratio of overshoot duration to the switching time period. Recommended design practice is to limit the overshoots to the absolute maximum pin voltages. This is accomplished with careful PCB layout to minimize parasitic inductances, choice of components with low ESL and addition of series resistance to limit rise times. For large overshoots, limiting the variability of the power supply may be required. For example, 0.5V of overshoot will be permissible with a maximum recommended supply of 5.25 V (5% variability); however, for larger overshoots, a supply with lower variability will be preferred.

8.2.4 Operating at Higher Frequency

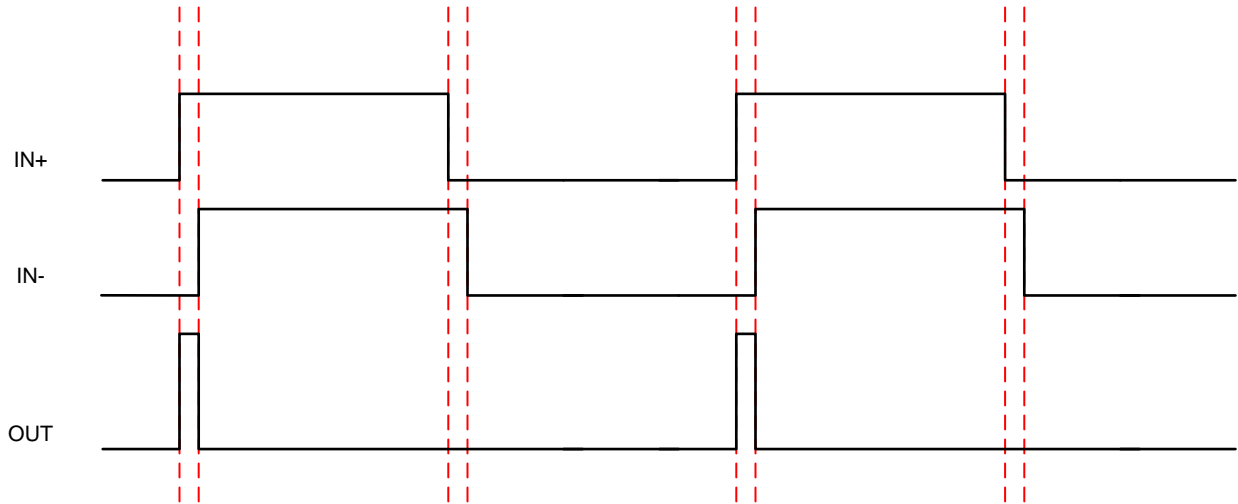
With fast rise/fall time, and capability of achieving 1 ns pulse width, depending on the capacitive load condition, the operating frequency of LMG1020 can be increased in a burst manner. In conditions which requires very high frequency pulsing, a pulse train with certain period of pause between each burst can be adopted to avoid overheating of the device. This will help maintain the RMS output current similar as lower frequency operation but boost the transient frequency to very high. In addition, higher decoupling capacitance will be needed to supply high frequency charging of the capacitive load.

Typical Application (接下页)

8.2.5 Application Curves



图 11. 90 ns Pulse from Function Generator Yielding 15 ns Pulse On The Input (Cyan) And Gate (Blue) After Pulse Shortening



图 12. 90 ns Pulse from Function Generator Yielding 1.5 ns Pulse On The Input (Cyan) And Gate (Blue) After Pulse Shortening

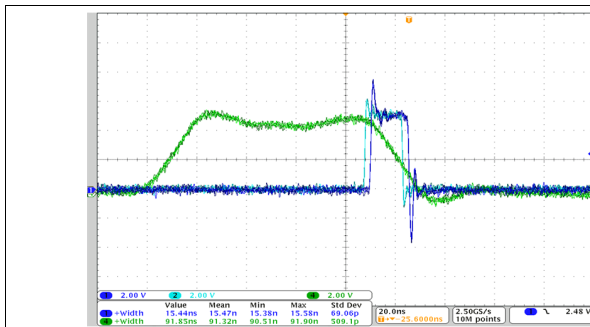

图 13. 1.2 ns Gate Pulse Yielding 1.5 ns 30V Into 1 Ω Pulse (500MHz Scope)

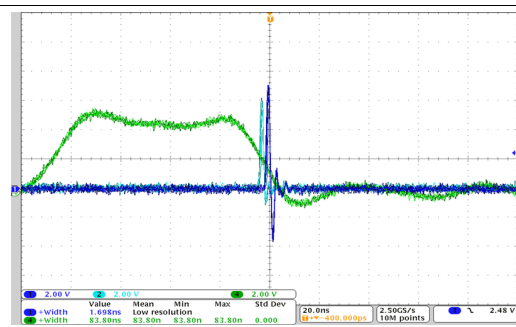

图 14. V_{DS} for 1.5 ns Pulse With 40V of Bus Voltage

图 11 和 图 12 是波形图，显示了脉冲短脉冲生成和输入/输出脉冲。90ns 长的脉冲（在绿色颜色）和它的延迟信号通过一个 AND 门，该门输出一个短脉冲信号作为 LMG1020 的输入。输出信号（在蓝色颜色）遵循输入（在青色颜色）具有某些传播延迟。一个输出脉冲短至 1.5 ns 可以获得如图 12。

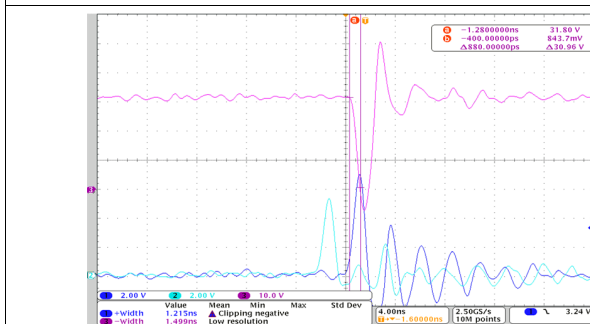
图 13 是用 500MHz 示波器拍摄的典型操作波形，包括输入逻辑门控信号（青色）、门控信号（蓝色）和开关 GaN FET 的漏极到源极信号（粉色）。在 FET 的漏极波形上，可以看到 20V 的过冲。这是由于功率回路中的电感引起的。Vg 似乎正在振荡，但这是由于拾取噪声引起的，即使使用弹簧接地连接也是不可避免的。

图 14 显示了 FET 由 LMG1020 驱动的漏极到源极电压的波形，具有 1.5ns 脉冲宽度和 300ps 下降时间，驱动最大 60A 电流，40V 总线电压。

9 Power Supply Recommendations

A low-ESR/ESL ceramic capacitor must be connected close to the IC, between V_{DD} and GND pins to support the high peak current being drawn from V_{DD} during turnon of the FETs. It is most desirable to place the V_{DD} decoupling capacitor on the same side of the PC board as the driver. The inductance of via holes can impose excessive ringing on the IC pins.

TI recommends the use of a three-terminal capacitor connecting in shunt-through manner to achieve the lowest ESL and best transient performance. This capacitor can be placed as close as possible to the IC, while another capacitor in larger capacitance can be placed closely to the three-terminal cap to supply enough charge but with slightly lower bandwidth. As a general practice, the combination of a 0.1 μF of 0402 or feed-through capacitor (closest to LMG1020) and a 1 μF 0603 capacitor is recommended.

10 Layout

10.1 Layout Guidelines

The layout of the LMG1020 is critical to its performance and functionality. The LMG1020 is available in a WCSP ball-grid array package, which enables low-inductance connection to a BGA-type GaN FET. [Figure 15](#) shows the recommended layout of the LMG1020 with a ball-grid array GaN FET. [Figure 16](#) presents a layout of LMG1020 with a 0.1 μF feed-through capacitor and a larger 1 μF capacitor.

A four-layer or higher layer count board is required to reduce the parasitic inductances of the layout to achieve suitable performance. To minimize inductance and board space, resistors and capacitors in the 0201 package are used here. The gate drive power loss must be calculated to ensure an 0201 resistor will be able to handle the power level.

10.1.1 Gate Drive Loop Inductance and Ground Connection

A compact, low-inductance gate-drive loop is essential to achieving fast switching frequencies with the LMG1020. The LMG1020 should be placed as close to the GaN FET as possible, with gate drive resistors R1 and R2 immediately connecting OUTH and OUTL to the FET gate. Large traces must be used to minimize resistance and parasitic inductance.

To minimize gate drive loop inductance, the source return should be on layer 2 of the PCB, immediately under the component (top) layer. Vias immediately adjacent to both the FET source and the LMG1020 GND pin connect to this plane with minimal impedance. Finally, take care to connect the GND plane to the source power plane only at the FET to minimize common-source inductance and to reduce coupling to the ground plane.

10.1.2 Bypass Capacitor

The VDD power terminal of the LMG1020 must be bypassed to ground immediately adjacent to the IC. Because of the fast gate drive of the IC, the placement and value of the bypass capacitor is critical. The bypass capacitor must be placed on the top layer, as close as possible to the IC, and connected to both VDD and GND using large power planes. This bypass capacitor has to be at least a 0.1 μF , up to 1 μF , with temperature coefficient X7R or better. Recommended body types are Low Inductance Chip Capacitor (LICC), Inter-Digitated Capacitor (IDC), Feed-through, and LGA. Finally, an additional 1 μF capacitor (not shown in [Figure 15](#)) must be placed as close to the IC as practical.

10.2 Layout Example

[Figure 15](#) presents a typical layout of LMG1020 with a 0402 decoupling capacitor C1, which is placed as close as possible to LMG1020. The ground return at GaN FET Kelvin source immediately flows through a via to the closest inner layer, and overlaps with the top layer traces.

[Figure 16](#) presents a layout of LMG1020 with a 0.1 μF feed-through capacitor (C1) and a larger 1 μF capacitor (C3) for decoupling. In this design, the feed-through capacitor C1 is placed in a shunt-through manner for lower noise decoupling, and C3 is placed next to C1. 0201 resistors are used at the output of LMG1020, which brings lower parasitic inductance than 0402 package.

Layout Example (接下页)



图 15. Typical LMG1020 Layout With Ball-Grid GaN FET And 0402 Decoupling Capacitor



图 16. Typical Layout Of LMG1020 And A Feed-Through Decoupling Capacitor With A Capacitor Load

11 器件和文档支持

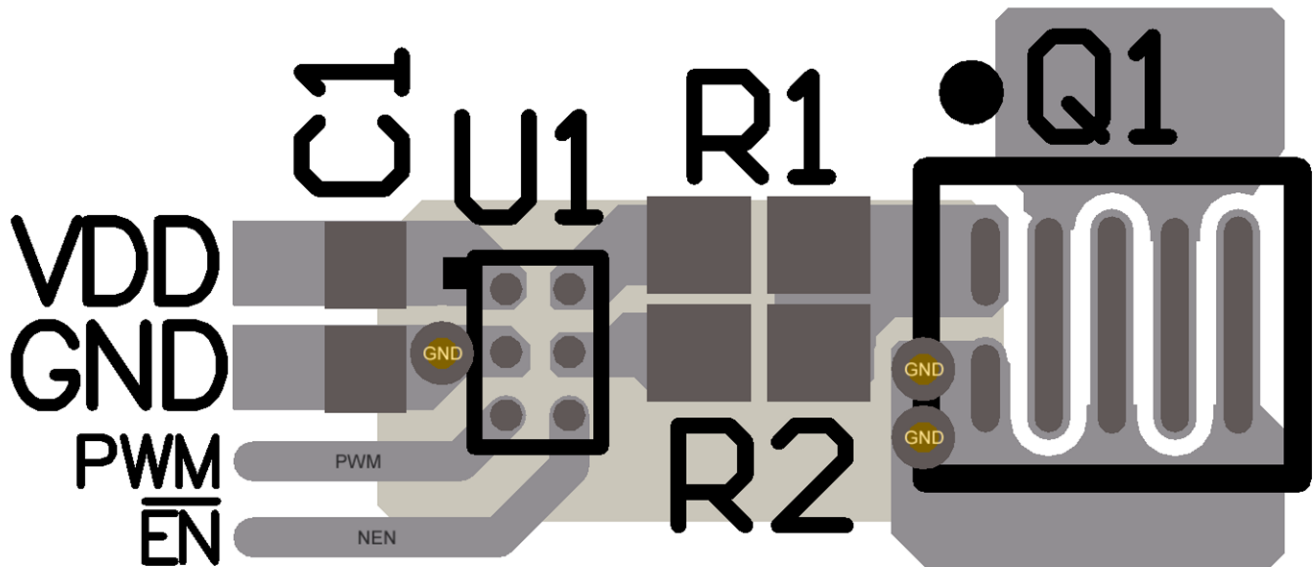
11.1 文档支持

11.1.1 相关文档

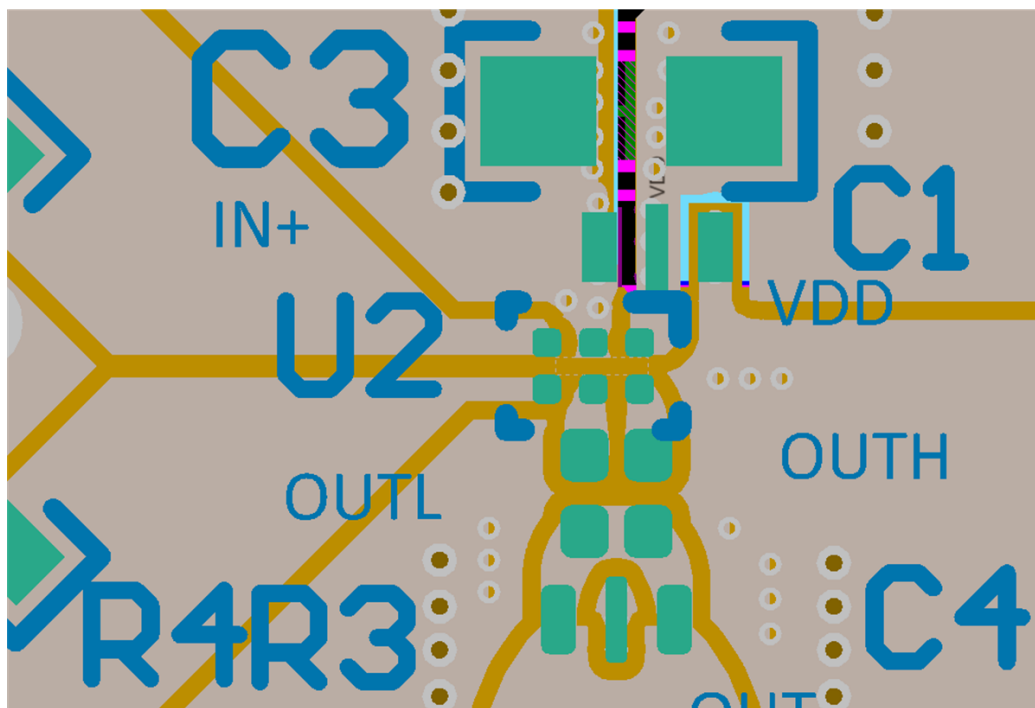
请参阅如下相关文档：

- [使用 LMG1020-EVM 纳秒 LiDAR EVM \(SNOU150\)](#)
- [《LMG1020 PSpice 瞬态模型》 \(SNOM618\)](#)
- [《LMG1020 TINA-TI 参考设计》 \(SNOM619\)](#)
- [《LMG1020 TINA-TI 瞬态 Spice 模型》 \(SNOM620\)](#)
- [《LMG1020EVM Altium 设计文件》 \(SNOR025\)](#)

11.2 接收文档更新通知

如需接收文档更新通知，请导航至 TI.com.cn 上的器件产品文件夹。单击右上角的 [通知我](#) 进行注册，即可每周接收产品信息更改摘要。有关更改的详细信息，请查看任何已修订文档中包含的修订历史记录。

11.3 社区资源

下列链接提供到 TI 社区资源的连接。链接的内容由各个分销商“按照原样”提供。这些内容并不构成 TI 技术规范，并且不一定反映 TI 的观点；请参阅 TI 的 [《使用条款》](#)。

TI E2E™ 在线社区 [TI 的工程师对工程师 \(E2E\) 社区](#)。此社区的创建目的在于促进工程师之间的协作。在 e2e.ti.com 中，您可以咨询问题、分享知识、拓展思路并与同行工程师一道帮助解决问题。

设计支持 [TI 参考设计支持](#) 可帮助您快速查找有帮助的 E2E 论坛、设计支持工具以及技术支持的联系信息。

11.4 商标

E2E is a trademark of Texas Instruments.
All other trademarks are the property of their respective owners.

11.5 静电放电警告



ESD 可能会损坏该集成电路。德州仪器 (TI) 建议通过适当的预防措施处理所有集成电路。如果不遵守正确的处理措施和安装程序，可能会损坏集成电路。

ESD 的损坏小至导致微小的性能降级，大至整个器件故障。精密的集成电路可能更容易受到损坏，这是因为非常细微的参数更改都可能会导致器件与其发布的规格不相符。

11.6 术语表

[SLYZ022](#) — TI 术语表。

这份术语表列出并解释术语、缩写和定义。

12 机械、封装和可订购信息

以下页面包含机械、封装和可订购信息。这些信息是指定器件的最新可用数据。数据如有变更，恕不另行通知，且不会对此文档进行修订。如需获取此数据表的浏览器版本，请查阅左侧的导航栏。

重要声明和免责声明

TI 均以“原样”提供技术性数据（包括数据表）、设计资源（包括参考设计）、应用或其他设计建议、网络工具、安全信息和其他资源，不保证其中不含任何瑕疵，且不做任何明示或暗示的担保，包括但不限于对适销性、适合某特定用途或不侵犯任何第三方知识产权的暗示担保。

所述资源可供专业开发人员应用TI 产品进行设计使用。您将对以下行为独自承担全部责任：(1) 针对您的应用选择合适的TI 产品；(2) 设计、验证并测试您的应用；(3) 确保您的应用满足相应标准以及任何其他安全、安保或其他要求。所述资源如有变更，恕不另行通知。TI 对您使用所述资源的授权仅限于开发资源所涉及TI 产品的相关应用。除此之外不得复制或展示所述资源，也不提供其它TI 或任何第三方的知识产权授权许可。如因使用所述资源而产生任何索赔、赔偿、成本、损失及债务等，TI 对此概不负责，并且您须赔偿由此对TI 及其代表造成的损害。

TI 所提供产品均受TI 的销售条款 (<http://www.ti.com.cn/zh-cn/legal/termsofsale.html>) 以及ti.com.cn上或随附TI产品提供的其他可适用条款的约束。TI提供所述资源并不扩展或以其他方式更改TI 针对TI 产品所发布的可适用的担保范围或担保免责声明。

邮寄地址：上海市浦东新区世纪大道 1568 号中建大厦 32 楼，邮政编码：200122
Copyright © 2019 德州仪器半导体技术（上海）有限公司

PACKAGING INFORMATION

Orderable Device	Status (1)	Package Type	Package Drawing	Pins	Package Qty	Eco Plan (2)	Lead finish/ Ball material (6)	MSL Peak Temp (3)	Op Temp (°C)	Device Marking (4/5)	Samples
LMG1020YFFR	ACTIVE	DSBGA	YFF	6	3000	RoHS & Green	SNAGCU	Level-1-260C-UNLIM	-40 to 125	AT	Samples
LMG1020YFFT	ACTIVE	DSBGA	YFF	6	250	RoHS & Green	SNAGCU	Level-1-260C-UNLIM	-40 to 125	AT	Samples

(1) The marketing status values are defined as follows:

ACTIVE: Product device recommended for new designs.

LIFEBUY: TI has announced that the device will be discontinued, and a lifetime-buy period is in effect.

NRND: Not recommended for new designs. Device is in production to support existing customers, but TI does not recommend using this part in a new design.

PREVIEW: Device has been announced but is not in production. Samples may or may not be available.

OBSELETE: TI has discontinued the production of the device.

(2) **RoHS:** TI defines "RoHS" to mean semiconductor products that are compliant with the current EU RoHS requirements for all 10 RoHS substances, including the requirement that RoHS substance do not exceed 0.1% by weight in homogeneous materials. Where designed to be soldered at high temperatures, "RoHS" products are suitable for use in specified lead-free processes. TI may reference these types of products as "Pb-Free".

RoHS Exempt: TI defines "RoHS Exempt" to mean products that contain lead but are compliant with EU RoHS pursuant to a specific EU RoHS exemption.

Green: TI defines "Green" to mean the content of Chlorine (Cl) and Bromine (Br) based flame retardants meet JS709B low halogen requirements of <=1000ppm threshold. Antimony trioxide based flame retardants must also meet the <=1000ppm threshold requirement.

(3) MSL, Peak Temp. - The Moisture Sensitivity Level rating according to the JEDEC industry standard classifications, and peak solder temperature.

(4) There may be additional marking, which relates to the logo, the lot trace code information, or the environmental category on the device.

(5) Multiple Device Markings will be inside parentheses. Only one Device Marking contained in parentheses and separated by a "~" will appear on a device. If a line is indented then it is a continuation of the previous line and the two combined represent the entire Device Marking for that device.

(6) Lead finish/Ball material - Orderable Devices may have multiple material finish options. Finish options are separated by a vertical ruled line. Lead finish/Ball material values may wrap to two lines if the finish value exceeds the maximum column width.

Important Information and Disclaimer:The information provided on this page represents TI's knowledge and belief as of the date that it is provided. TI bases its knowledge and belief on information provided by third parties, and makes no representation or warranty as to the accuracy of such information. Efforts are underway to better integrate information from third parties. TI has taken and continues to take reasonable steps to provide representative and accurate information but may not have conducted destructive testing or chemical analysis on incoming materials and chemicals. TI and TI suppliers consider certain information to be proprietary, and thus CAS numbers and other limited information may not be available for release.

In no event shall TI's liability arising out of such information exceed the total purchase price of the TI part(s) at issue in this document sold by TI to Customer on an annual basis.

TAPE AND REEL INFORMATION

QUADRANT ASSIGNMENTS FOR PIN 1 ORIENTATION IN TAPE

*All dimensions are nominal

Device	Package Type	Package Drawing	Pins	SPQ	Reel Diameter (mm)	Reel Width W1 (mm)	A0 (mm)	B0 (mm)	K0 (mm)	P1 (mm)	W (mm)	Pin1 Quadrant
LMG1020YFFR	DSBGA	YFF	6	3000	180.0	8.4	0.96	1.36	0.69	4.0	8.0	Q1
LMG1020YFFT	DSBGA	YFF	6	250	180.0	8.4	0.96	1.36	0.69	4.0	8.0	Q1

TAPE AND REEL BOX DIMENSIONS

*All dimensions are nominal

Device	Package Type	Package Drawing	Pins	SPQ	Length (mm)	Width (mm)	Height (mm)
LMG1020YFFR	DSBGA	YFF	6	3000	182.0	182.0	20.0
LMG1020YFFT	DSBGA	YFF	6	250	182.0	182.0	20.0

YFF0006

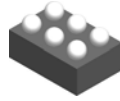

PACKAGE OUTLINE

DSBGA - 0.625 mm max height

DIE SIZE BALL GRID ARRAY

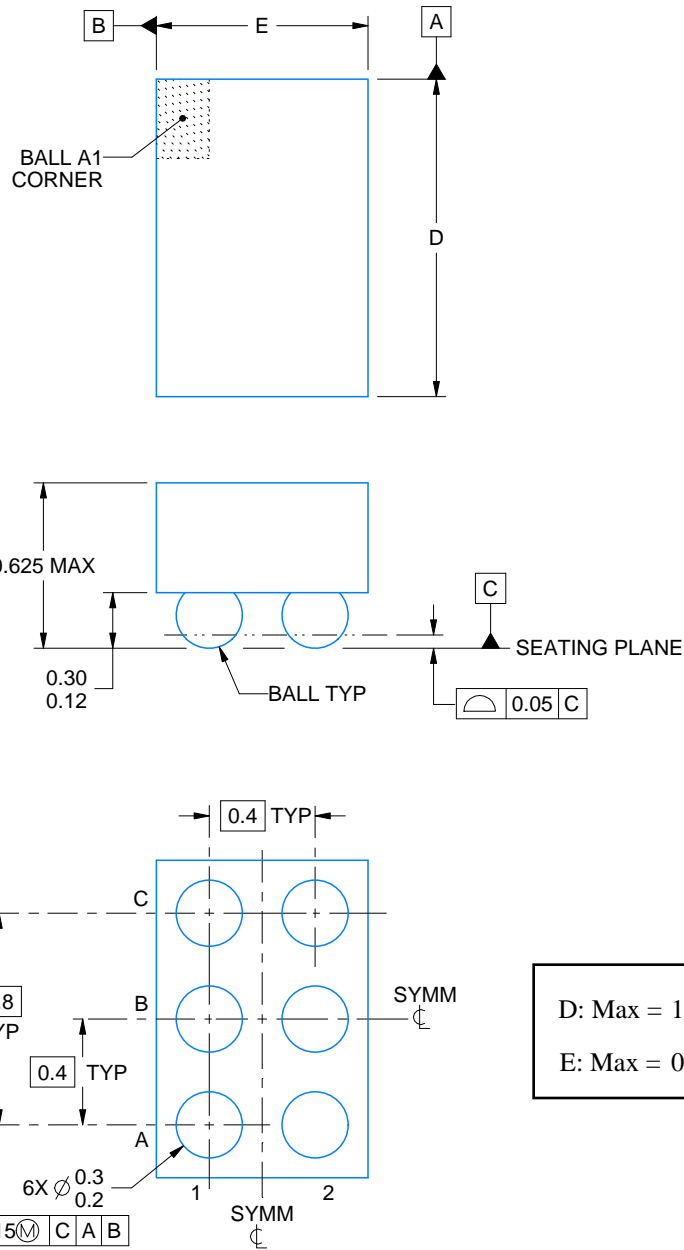

D: Max = 1.285 mm, Min = 1.225 mm
E: Max = 0.885 mm, Min = 0.825 mm

4223785/A 06/2017

NOTES:

1. All linear dimensions are in millimeters. Any dimensions in parenthesis are for reference only. Dimensioning and tolerancing per ASME Y14.5M.
2. This drawing is subject to change without notice.

EXAMPLE BOARD LAYOUT

YFF0006

DSBGA - 0.625 mm max height

DIE SIZE BALL GRID ARRAY

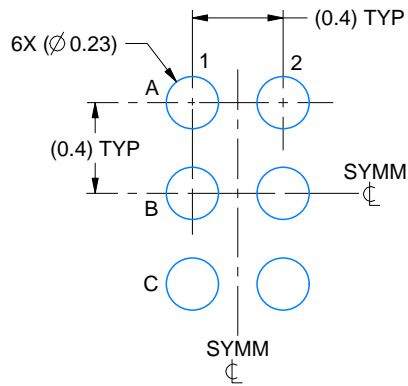

LAND PATTERN EXAMPLE
EXPOSED METAL SHOWN
SCALE:30X

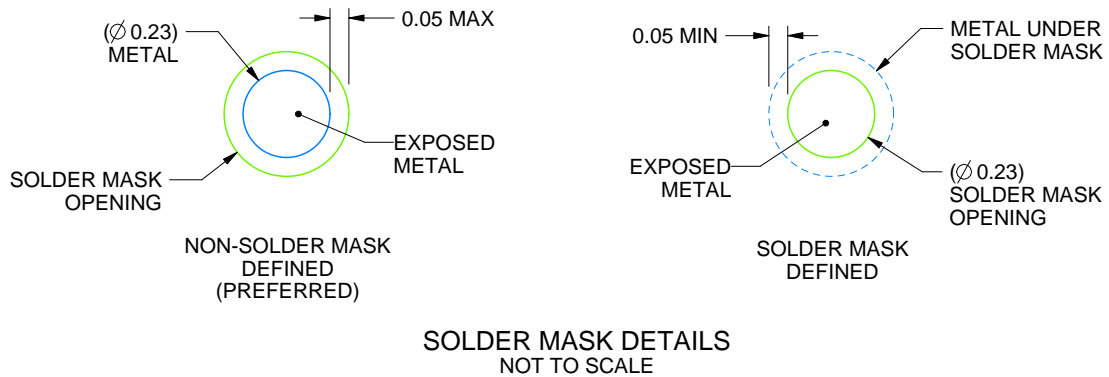

SOLDER MASK DETAILS
NOT TO SCALE

4223785/A 06/2017

NOTES: (continued)

- Final dimensions may vary due to manufacturing tolerance considerations and also routing constraints. For more information, see Texas Instruments literature number SNVA009 (www.ti.com/lit/snva009).

EXAMPLE STENCIL DESIGN

YFF0006

DSBGA - 0.625 mm max height

DIE SIZE BALL GRID ARRAY

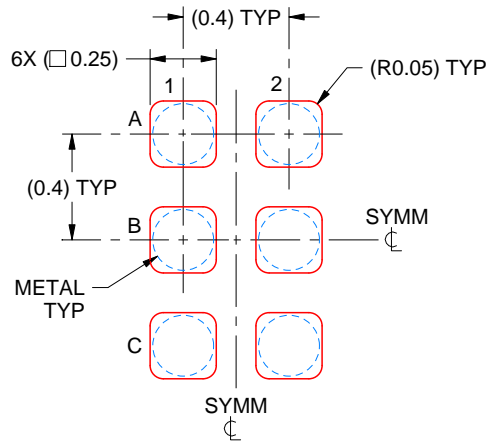

SOLDER PASTE EXAMPLE
BASED ON 0.1 mm THICK STENCIL
SCALE:35X

4223785/A 06/2017

NOTES: (continued)

4. Laser cutting apertures with trapezoidal walls and rounded corners may offer better paste release.

重要声明和免责声明

TI 均以“原样”提供技术性及其可靠性数据（包括数据表）、设计资源（包括参考设计）、应用或其他设计建议、网络工具、安全信息和其他资源，不保证其中不含任何瑕疵，且不做任何明示或暗示的担保，包括但不限于对适销性、适合某特定用途或不侵犯任何第三方知识产权的暗示担保。

所述资源可供专业开发人员应用TI 产品进行设计使用。您将对以下行为独自承担全部责任：(1) 针对您的应用选择合适的TI 产品；(2) 设计、验证并测试您的应用；(3) 确保您的应用满足相应标准以及任何其他安全、安保或其他要求。所述资源如有变更，恕不另行通知。TI 对您使用所述资源的授权仅限于开发资源所涉及TI 产品的相关应用。除此之外不得复制或展示所述资源，也不提供其它TI 或任何第三方的知识产权授权许可。如因使用所述资源而产生任何索赔、赔偿、成本、损失及债务等，TI 对此概不负责，并且您须赔偿由此对TI 及其代表造成的损害。

TI 所提供产品均受TI 的销售条款 (<http://www.ti.com.cn/zh-cn/legal/termsofsale.html>) 以及ti.com.cn上或随附TI产品提供的其他可适用条款的约束。TI提供所述资源并不扩展或以其他方式更改TI 针对TI 产品所发布的可适用的担保范围或担保免责声明。

邮寄地址：上海市浦东新区世纪大道 1568 号中建大厦 32 楼，邮政编码：200122

Copyright © 2020 德州仪器半导体技术（上海）有限公司

X-ON Electronics

Largest Supplier of Electrical and Electronic Components

Click to view similar products for [Gate Drivers](#) category:

Click to view products by [Texas Instruments](#) manufacturer:

Other Similar products are found below :

[56956](#) [57.404.7355.5](#) [LT4936](#) [57.904.0755.0](#) [5811-0902](#) [0131700000](#) [LTP70N06](#) [LVP640](#) [5J0-1000LG-SIL](#) [LY2-US-AC240](#) [LY3-UA-DC24](#) [LZNQ2-US-DC12](#) [LZP40N10](#) [60100564](#) [60249-1-CUT-TAPE](#) [0134220000](#) [60713816](#) [61161-90](#) [6131-204-23149P](#) [6131-205-17149P](#) [6131-209-15149P](#) [6131-218-17149P](#) [6131-220-21149P](#) [6131-260-2358P](#) [6131-265-11149P](#) [CS1HCPU63](#) [6150-5001](#) [CSB4](#) [CSK-38-60006](#) [CSK-38-60008](#) [621A](#) [622-4053LF](#) [6273](#) [M40N08MA-H](#) [M55155/29XH06](#) [64-807](#) [65-1930-6](#) [CV500ISB02](#) [M83723/88Y1407N](#) [CWD012-2](#) [CWD03-3](#) [CX3225SB16934D0PPSC2](#) [CX5032GB10000D0PPS02](#) [687-772NF1](#) [70.140.1653](#) [70.200.0653.0](#) [703001B01F060](#) [70-3601](#) [706006D02F0601](#) [706210](#)