

## 采用 QFN 封装且具有 2.95V-6V 输入的 LMZ30606 6A 电源模块

### 1 特性

- 完整的集成式电源解决方案可实现小尺寸和扁平设计
- 9mm x 11mm x 2.8mm 封装
  - 与 LMZ30602 & LMZ30604 引脚兼容
- 效率高达 96%
- 宽输出电压调节范围 0.8V 至 3.6V，基准精度为  $\pm 1\%$
- 可调开关频率 (500kHz 至 2MHz)
- 与外部时钟同步
- 可调慢速启动
- 输出电压排序/跟踪
- 电源正常输出
- 可编程欠压锁定 (UVLO)
- 输出过流保护
- 过热保护
- 运行温度范围:  $-40^{\circ}\text{C}$  至  $85^{\circ}\text{C}$
- 增强的散热性能:  $12^{\circ}\text{C}/\text{W}$
- 符合 EN55022 B 类辐射标准
  - 集成屏蔽电感器
- 使用 LMZ30606 并借助 WEBENCH® 电源设计器创建定制设计方案

### 2 应用

- 宽带和通信基础设施
- 自动化测试和医疗设备
- 紧凑型 PCI/PCI 快速接口/PXI 快速接口
- DSP 和 FPGA 负载点应用
- 高密度分布式电源系统

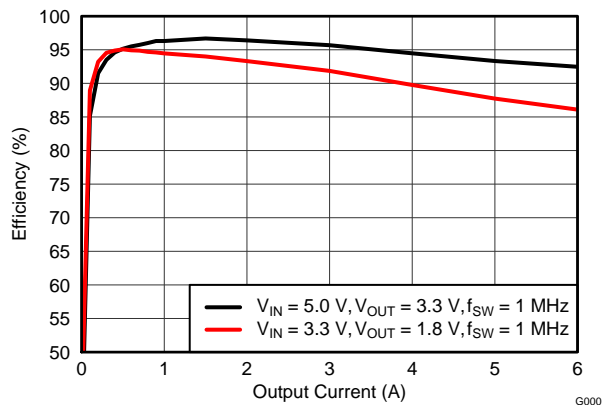

### 3 说明

LMZ30606 SIMPLE SWITCHER® 电源模块是一款易于使用的集成式电源解决方案，此方案在一半高的 QFN 封装内组合了一个带有功率金属氧化物半导体场效应管 (MOSFET) 的 6A 直流/直流转换器、一个屏蔽电感器以及无源元件。此整体电源解决方案仅需 3 个外部组件，并省去了环路补偿和磁性元件选择过程。

9mm x 11mm x 2.8 mm QFN 封装能轻松焊接到印刷电路板上，并且可实现效率高于 90% 的紧凑型负载点设计以及结至环境的热阻抗仅为  $12^{\circ}\text{C}/\text{W}$  的出色功率耗散。在环境温度为  $85^{\circ}\text{C}$  且无气流的情况下，该器件可提供 6A 的满额输出电流。

LMZ30606 提供了分离式负载点设计的灵活性和功能集，非常适合为高性能 DSP 和 FPGA 供电。先进的封装技术可提供一个与标准 QFN 贴装和测试技术兼容的耐用且可靠的电源解决方案。

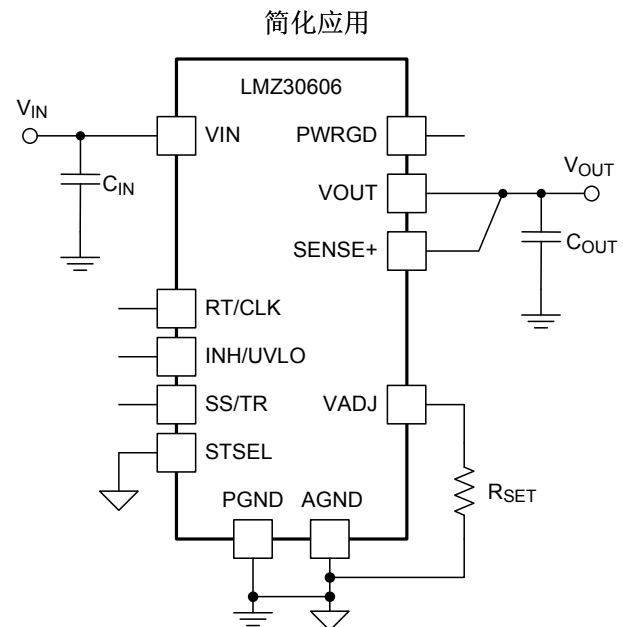

**Table 1. Ordering Information**

For the most current package and ordering information, see the Package Option Addendum at the end of this datasheet, or see the TI website at [www.ti.com](http://www.ti.com).

## 4 Specifications

### 4.1 Absolute Maximum Ratings<sup>(1)</sup>

over operating temperature range (unless otherwise noted)

		VALUE		UNIT
		MIN	MAX	
Input Voltage	VIN, PWRGD	-0.3	7	V
	INH/UVLO, RT/CLK	-0.3	3.3	V
	SS/TR, STSEL, VADJ	-0.3	3	V
	SENSE+      VADJ rating must also be met	-0.3	V <sub>OUT</sub>	V
Output Voltage	PH	-0.6	7	V
	PH 10 ns, transient	-2	7	V
	VOUT	-0.6	VIN	V
V <sub>DIFF</sub> (GND to exposed thermal pad)		-0.2	0.2	V
Source Current	RT/CLK, INH/UVLO	±100		µA
	PH	Current Limit		A
Sink Current	PH	Current Limit		A
	SS/TR	±100		µA
	PWRGD	10		mA
	Operating Junction Temperature	-40	125 <sup>(2)</sup>	°C
Storage Temperature, T <sub>stg</sub>		-65	150	°C
Peak Reflow Case Temperature <sup>(3)</sup>		250 <sup>(4)</sup>		°C
Maximum Number of Reflows Allowed <sup>(3)</sup>		3 <sup>(4)</sup>		
Mechanical Shock	Mil-STD-883D, Method 2002.3, 1 msec, 1/2 sine, mounted	1500		G
Mechanical Vibration	Mil-STD-883D, Method 2007.2, 20-2000Hz	20		

- (1) Stresses beyond those listed under absolute maximum ratings may cause permanent damage to the device. These are stress ratings only, and functional operation of the device at these or any other conditions beyond those indicated under recommended operating conditions is not implied. Exposure to absolute-maximum-rated conditions for extended periods may affect device reliability.
- (2) See the temperature derating curves in the Typical Characteristics section for thermal information.
- (3) For soldering specifications, refer to the [Soldering Requirements for BQFN Packages](#) application note.
- (4) Devices with a date code prior to week 14 2018 (1814) have a peak reflow case temperature of 240°C with a maximum of one reflow.

### 4.2 Thermal Information

THERMAL METRIC <sup>(1)</sup>		LMZ30606	UNIT
		RKG39	
		39 PINS	
θ <sub>JA</sub>	Junction-to-ambient thermal resistance <sup>(2)</sup>	12	°C/W
ψ <sub>JT</sub>	Junction-to-top characterization parameter <sup>(3)</sup>	2.2	
ψ <sub>JB</sub>	Junction-to-board characterization parameter <sup>(4)</sup>	9.7	

- (1) For more information about traditional and new thermal metrics, see the [Semiconductor and IC Package Thermal Metrics](#) (SPRA953) application report.
- (2) The junction-to-ambient thermal resistance, θ<sub>JA</sub>, applies to devices soldered directly to a 100 mm x 100 mm double-sided PCB with 1 oz. copper and natural convection cooling. Additional airflow reduces θ<sub>JA</sub>.
- (3) The junction-to-top characterization parameter, ψ<sub>JT</sub>, estimates the junction temperature, T<sub>J</sub>, of a device in a real system, using a procedure described in JESD51-2A (sections 6 and 7). T<sub>J</sub> = ψ<sub>JT</sub> \* P<sub>dis</sub> + T<sub>T</sub>; where P<sub>dis</sub> is the power dissipated in the device and T<sub>T</sub> is the temperature of the top of the device.
- (4) The junction-to-board characterization parameter, ψ<sub>JB</sub>, estimates the junction temperature, T<sub>J</sub>, of a device in a real system, using a procedure described in JESD51-2A (sections 6 and 7). T<sub>J</sub> = ψ<sub>JB</sub> \* P<sub>dis</sub> + T<sub>B</sub>; where P<sub>dis</sub> is the power dissipated in the device and T<sub>B</sub> is the temperature of the board 1mm from the device.

### 4.3 Electrical Characteristics

Over  $-40^{\circ}\text{C}$  to  $85^{\circ}\text{C}$  free-air temperature,  $V_{\text{IN}} = 3.3\text{ V}$ ,  $V_{\text{OUT}} = 1.8\text{ V}$ ,  $I_{\text{OUT}} = 6\text{ A}$ ,  $C_{\text{IN}1} = 47\text{ }\mu\text{F}$  ceramic,  $C_{\text{IN}2} = 220\text{ }\mu\text{F}$  poly-tantalum,  $C_{\text{OUT}1} = 47\text{ }\mu\text{F}$  ceramic,  $C_{\text{OUT}2} = 100\text{ }\mu\text{F}$  poly-tantalum (unless otherwise noted)

PARAMETER		TEST CONDITIONS	MIN	TYP	MAX	UNIT	
$I_{\text{OUT}}$	Output current	$T_{\text{A}} = 85^{\circ}\text{C}$ , natural convection	0		6	A	
$V_{\text{IN}}$	Input voltage range	Over $I_{\text{OUT}}$ range	2.95 <sup>(1)</sup>		6	V	
UVLO	VIN Undervoltage lockout	VIN = increasing		3.05	3.135	V	
		VIN = decreasing	2.5	2.75			
$V_{\text{OUT(adj)}}$	Output voltage adjust range	Over $I_{\text{OUT}}$ range	0.8		3.6	V	
$V_{\text{OUT}}$	Set-point voltage tolerance	$T_{\text{A}} = 25^{\circ}\text{C}$ , $I_{\text{OUT}} = 0\text{ A}$			$\pm 1.0\%$ <sup>(2)</sup>		
	Temperature variation	$-40^{\circ}\text{C} \leq T_{\text{A}} \leq +85^{\circ}\text{C}$ , $I_{\text{OUT}} = 0\text{ A}$		$\pm 0.3\%$			
	Line regulation	Over VIN range, $T_{\text{A}} = 25^{\circ}\text{C}$ , $I_{\text{OUT}} = 0\text{ A}$		$\pm 0.1\%$			
	Load regulation	Over $I_{\text{OUT}}$ range, $T_{\text{A}} = 25^{\circ}\text{C}$		$\pm 0.1\%$			
	Total output voltage variation	Includes set-point, line, load, and temperature variation				$\pm 1.5\%$ <sup>(2)</sup>	
$\eta$	Efficiency	$V_{\text{IN}} = 5\text{ V}$ $I_{\text{O}} = 3\text{ A}$	$V_{\text{OUT}} = 3.3\text{ V}$ , $f_{\text{SW}} = 1\text{ MHz}$		96%		
			$V_{\text{OUT}} = 2.5\text{ V}$ , $f_{\text{SW}} = 1\text{ MHz}$		94%		
			$V_{\text{OUT}} = 1.8\text{ V}$ , $f_{\text{SW}} = 1\text{ MHz}$		92%		
			$V_{\text{OUT}} = 1.5\text{ V}$ , $f_{\text{SW}} = 1\text{ MHz}$		90%		
			$V_{\text{OUT}} = 1.2\text{ V}$ , $f_{\text{SW}} = 750\text{ kHz}$		89%		
			$V_{\text{OUT}} = 1.0\text{ V}$ , $f_{\text{SW}} = 650\text{ kHz}$		87%		
		$V_{\text{IN}} = 3.3\text{ V}$ $I_{\text{O}} = 3\text{ A}$	$V_{\text{OUT}} = 0.8\text{ V}$ , $f_{\text{SW}} = 650\text{ kHz}$		85%		
			$V_{\text{OUT}} = 1.8\text{ V}$ , $f_{\text{SW}} = 1\text{ MHz}$		92%		
			$V_{\text{OUT}} = 1.5\text{ V}$ , $f_{\text{SW}} = 1\text{ MHz}$		90%		
			$V_{\text{OUT}} = 1.2\text{ V}$ , $f_{\text{SW}} = 750\text{ kHz}$		89%		
			$V_{\text{OUT}} = 1.0\text{ V}$ , $f_{\text{SW}} = 650\text{ kHz}$		87%		
			$V_{\text{OUT}} = 0.8\text{ V}$ , $f_{\text{SW}} = 650\text{ kHz}$		85%		
	Output voltage ripple	20 MHz bandwidth		10		mV <sub>PP</sub>	
$I_{\text{LIM}}$	Overcurrent threshold			9		A	
	Transient response	1.0 A/ $\mu\text{s}$ load step from 1.5A to 4.5A	Recovery time		80	$\mu\text{s}$	
			$V_{\text{OUT}}$ over/undershoot		120	mV	
$V_{\text{INH-H}}$	Inhibit Control	Inhibit High Voltage		1.25	Open <sup>(3)</sup>	V	
$V_{\text{INH-L}}$		Inhibit Low Voltage	-0.3	1.0			
$I_{\text{I(stby)}}$	Input standby current	INH pin to AGND		70	100	$\mu\text{A}$	
Power Good	PWRGD Thresholds	$V_{\text{OUT}}$ rising	Good		93%		
			Fault		109%		
		$V_{\text{OUT}}$ falling	Fault		91%		
			Good		107%		
	PWRGD Low Voltage	$I(\text{PWRGD}) = 0.33\text{ mA}$			0.3	V	
$f_{\text{SW}}$	Switching frequency	Over VIN and $I_{\text{OUT}}$ ranges, RT/CLK pin OPEN	400	500	600	kHz	
$f_{\text{CLK}}$	Synchronization frequency		500		2000	kHz	
$V_{\text{CLK-H}}$	CLK High-Level Threshold	CLK Control		2.2	3.3	V	
$V_{\text{CLK-L}}$	CLK Low-Level Threshold			-0.3	0.4	V	
CLK_PW	CLK Pulse Width			75 <sup>(4)</sup>		ns	
	Thermal Shutdown	Thermal shutdown		170		$^{\circ}\text{C}$	
		Thermal shutdown hysteresis		20		$^{\circ}\text{C}$	

- (1) The minimum VIN depends on  $V_{\text{OUT}}$  and the switching frequency. Please refer to [Table 9](#) for operating limits.
- (2) The stated limit of the set-point voltage tolerance includes the tolerance of both the internal voltage reference and the internal adjustment resistor. The overall output voltage tolerance will be affected by the tolerance of the external  $R_{\text{SET}}$  resistor.
- (3) This control pin has an internal pullup. Do not place an external pull-up resistor on this pin. If this pin is left open circuit, the device operates when input power is applied. A small low-leakage MOSFET is recommended for control. See the application section for further guidance.
- (4) The maximum synchronization clock pulse width is dependant on VIN,  $V_{\text{OUT}}$ , and the synchronization frequency. See the [Synchronization \(CLK\)](#) section for more information.

## Electrical Characteristics (continued)

Over  $-40^{\circ}\text{C}$  to  $85^{\circ}\text{C}$  free-air temperature,  $V_{\text{IN}} = 3.3\text{ V}$ ,  $V_{\text{OUT}} = 1.8\text{ V}$ ,  $I_{\text{OUT}} = 6\text{ A}$ ,  
 $C_{\text{IN}1} = 47\text{ }\mu\text{F}$  ceramic,  $C_{\text{IN}2} = 220\text{ }\mu\text{F}$  poly-tantalum,  $C_{\text{OUT}1} = 47\text{ }\mu\text{F}$  ceramic,  $C_{\text{OUT}2} = 100\text{ }\mu\text{F}$  poly-tantalum (unless otherwise noted)

PARAMETER		TEST CONDITIONS	MIN	TYP	MAX	UNIT
$C_{\text{IN}}$	External input capacitance	Ceramic	47 <sup>(5)</sup>			$\mu\text{F}$
		Non-ceramic		220 <sup>(5)</sup>		
$C_{\text{OUT}}$	External output capacitance	Ceramic	47 <sup>(6)</sup>	150	650 <sup>(7)</sup>	$\mu\text{F}$
		Non-ceramic		100 <sup>(6)</sup>	2000 <sup>(7)</sup>	
		Equivalent series resistance (ESR)				25

- (5) A minimum of  $47\mu\text{F}$  of ceramic capacitance is required across the input for proper operation. Locate the capacitor close to the device. An additional  $220\mu\text{F}$  of bulk capacitance is recommended. See [Table 6](#) for more details.
- (6) The amount of required output capacitance varies depending on the output voltage (see [Table 5](#)). The amount of required capacitance must include at least  $47\mu\text{F}$  of ceramic capacitance. Locate the capacitance close to the device. Adding additional capacitance close to the load improves the response of the regulator to load transients. See [Table 5](#) and [Table 6](#) for more details.
- (7) When using both ceramic and non-ceramic output capacitance, the combined maximum must not exceed  $2200\mu\text{F}$ .

## 4.4 Package Specifications

LMZ30606		UNIT
Weight		0.85 grams
Flammability	Meets UL 94 V-O	
MTBF Calculated reliability	Per Bellcore TR-332, 50% stress, $T_A = 40^{\circ}\text{C}$ , ground benign	32.8 Mhrs

5 Device Information

FUNCTIONAL BLOCK DIAGRAM

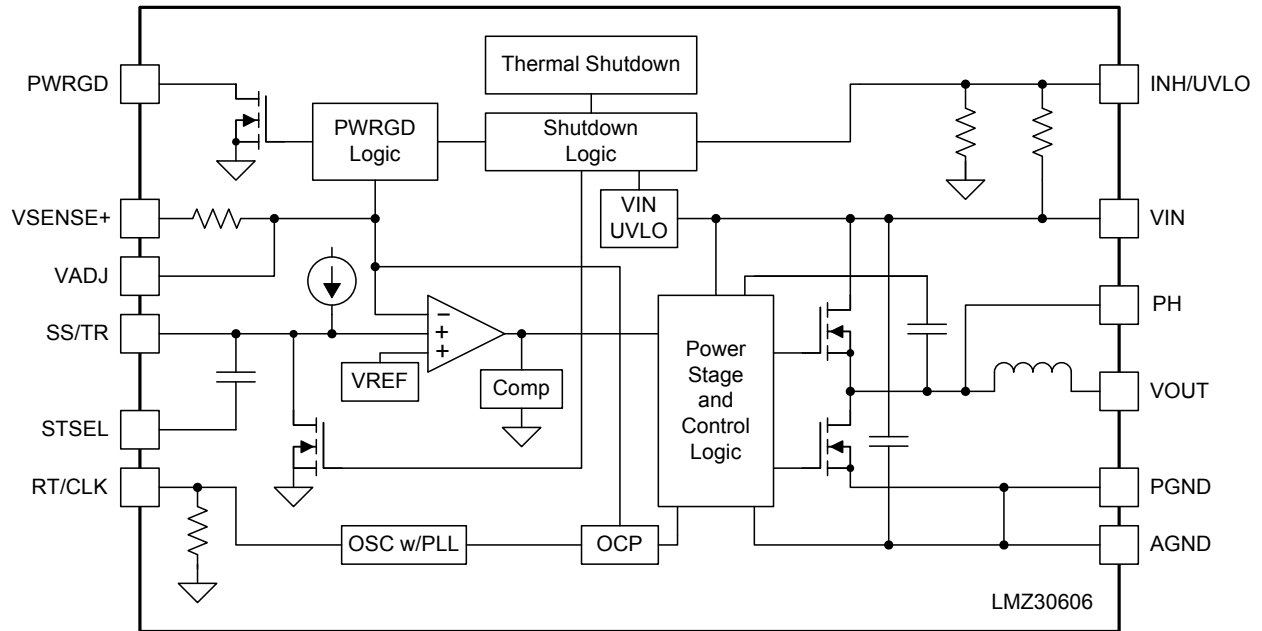

**Table 2. PIN DESCRIPTIONS**

TERMINAL		DESCRIPTION
NAME	NO.	
AGND	1	Zero VDC reference for the analog control circuitry. These pins should be connected directly to the PCB analog ground plane. Not all pins are connected together internally. All pins must be connected together externally with a copper plane or pour directly under the module. Connect the AGND copper area to the PGND copper area at a single point; directly at the pin 37 PowerPAD using multiple vias. See the recommended layout in <a href="#">Figure 36</a> .
	5	
	29	
	33	
	34	
PowerPAD (PGND)	37	This pad provides both an electrical and thermal connection to the PCB. This pad should be connected directly to the PCB power ground plane using multiple vias for good electrical and thermal performance. The same vias should also be used to connect to the PCB analog ground plane. See the recommended layout in <a href="#">Figure 36</a> .
DNC	2	Do Not Connect. Do not connect these pins to AGND, to another DNC pin, or to any other voltage. These pins are connected to internal circuitry. Each pin must be soldered to an isolated pad.
	3	
	15	
	16	
	26	
INH/UVLO	28	Inhibit and UVLO adjust pin. Use an open drain or open collector output logic to control the INH function. A resistor between this pin and AGND adjusts the UVLO voltage.
PH	17	Phase switch node. These pins should be connected by a small copper island under the device for thermal relief. Do not connect any external component to this pin or tie it to a pin of another function.
	18	
	19	
	20	
	21	
	22	
	23	
	24	
	25	
39		
PWRGD	27	Power good fault pin. Asserts low if the output voltage is out of tolerance. A pull-up resistor is required.
RT/CLK	4	This pin automatically selects between RT mode and CLK mode. An external timing resistor adjusts the switching frequency of the device. In CLK mode, the device synchronizes to an external clock.
SENSE+	36	Remote sense connection. Connect this pin to VOUT at the load for improved regulation. This pin must be connected to VOUT at the load, or at the module pins.
SS/TR	6	Slow-start and tracking pin. Connecting an external capacitor to this pin adjusts the output voltage rise time. A voltage applied to this pin allows for tracking and sequencing control.
STSEL	7	Slow-start or track feature select. Connect this pin to AGND to enable the internal SS capacitor with a SS interval of approximately 1.1 ms. Leave this pin open to enable the TR feature.
VADJ	35	Connecting a resistor between this pin and AGND sets the output voltage above the 0.8V default voltage.
VIN	30	The positive input voltage power pins, which are referenced to PGND. Connect external input capacitance between these pins and the PGND plane, close to the device.
	31	
	32	
VOUT	8	Output voltage. Connect output capacitors between these pins and the PGND plane, close to the device.
	9	
	10	
	11	
	12	
	13	
	14	
	38	

RKG PACKAGE  
39 PINS  
(TOP VIEW)

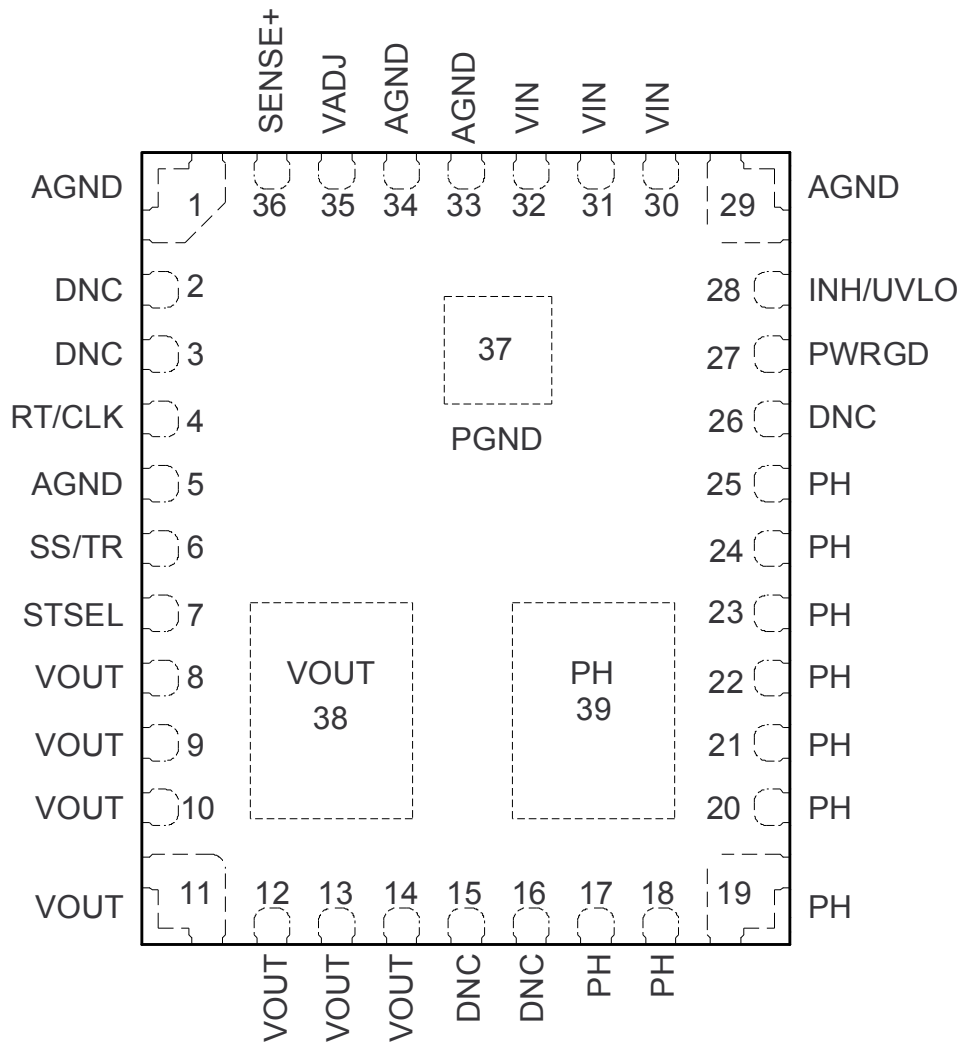

## 6 Typical Characteristics (VIN = 5 V)

The electrical characteristic data has been developed from actual products tested at 25°C. This data is considered typical for the converter. Applies to Figure 1, Figure 2, and Figure 3. The temperature derating curves represent the conditions at which internal components are at or below the manufacturer's maximum operating temperatures. Derating limits apply to devices soldered directly to a 100 mm × 100 mm double-sided PCB with 1 oz. copper. Applies to Figure 4.

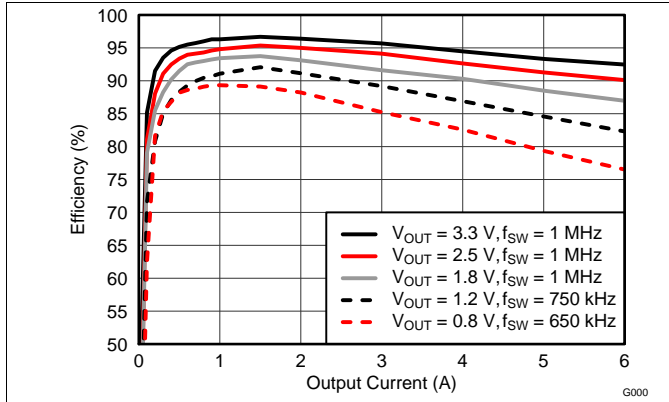

Figure 1. Efficiency vs. Output Current

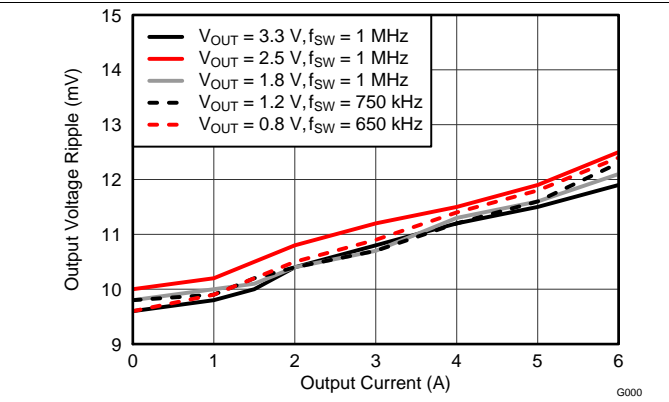

Figure 2. Voltage Ripple vs. Output Current

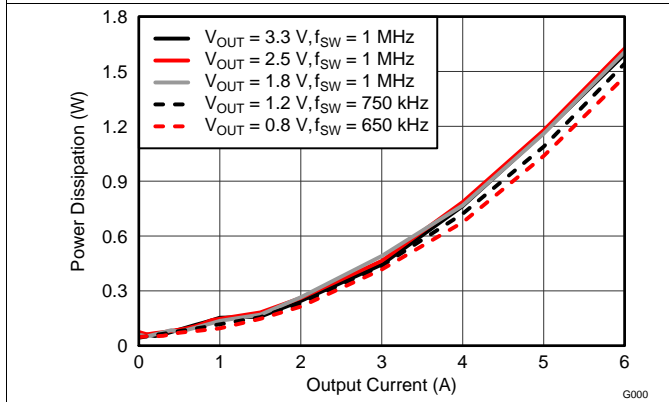

Figure 3. Power Dissipation vs. Output Current

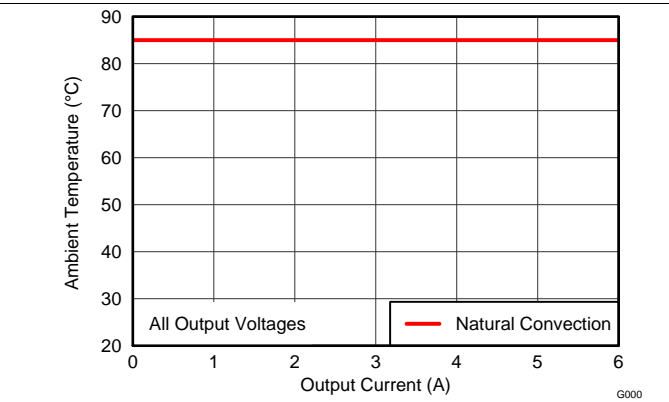

Figure 4. Safe Operating Area

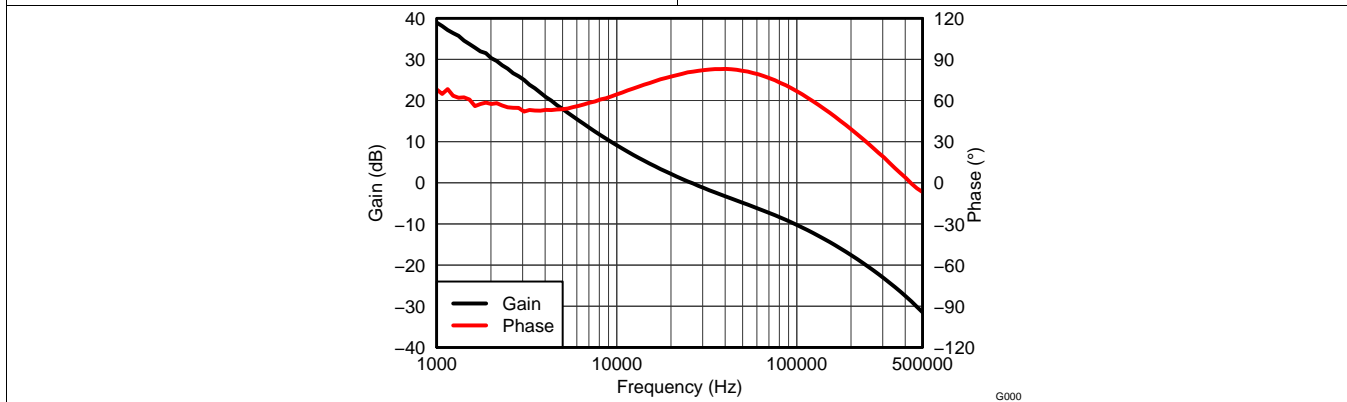

Figure 5.  $V_{OUT} = 1.8\text{ V}$ ,  $I_{OUT} = 6\text{ A}$ ,  $C_{OUT1} = 47\text{ }\mu\text{F}$  ceramic,  $C_{OUT2} = 100\text{ }\mu\text{F}$  POSCAP,  $f_{SW} = 1\text{ MHz}$



## 7 Typical Characteristics (VIN = 3.3 V)

The electrical characteristic data has been developed from actual products tested at 25°C. This data is considered typical for the converter. Applies to Figure 6, Figure 7, and Figure 8. The temperature derating curves represent the conditions at which internal components are at or below the manufacturer's maximum operating temperatures. Derating limits apply to devices soldered directly to a 100 mm × 100 mm double-sided PCB with 1 oz. copper. Applies to Figure 9.

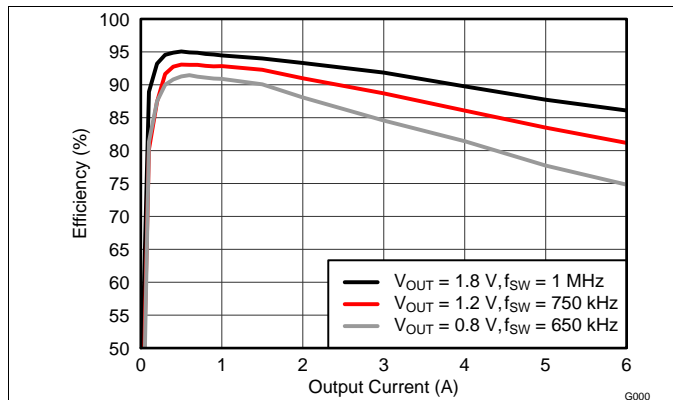

Figure 6. Efficiency vs. Output Current

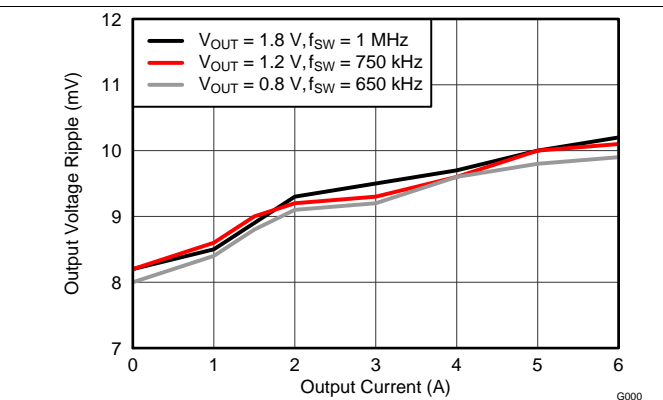

Figure 7. Voltage Ripple vs. Output Current

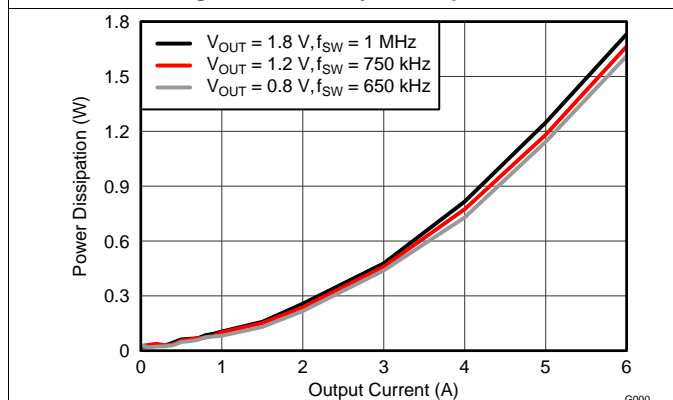

Figure 8. Power Dissipation vs. Output Current

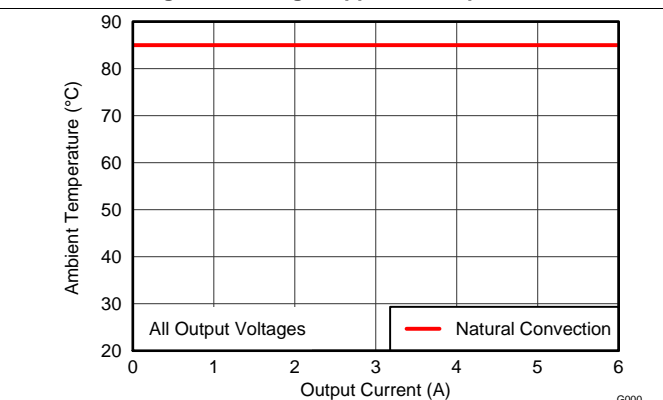

Figure 9. Safe Operating Area

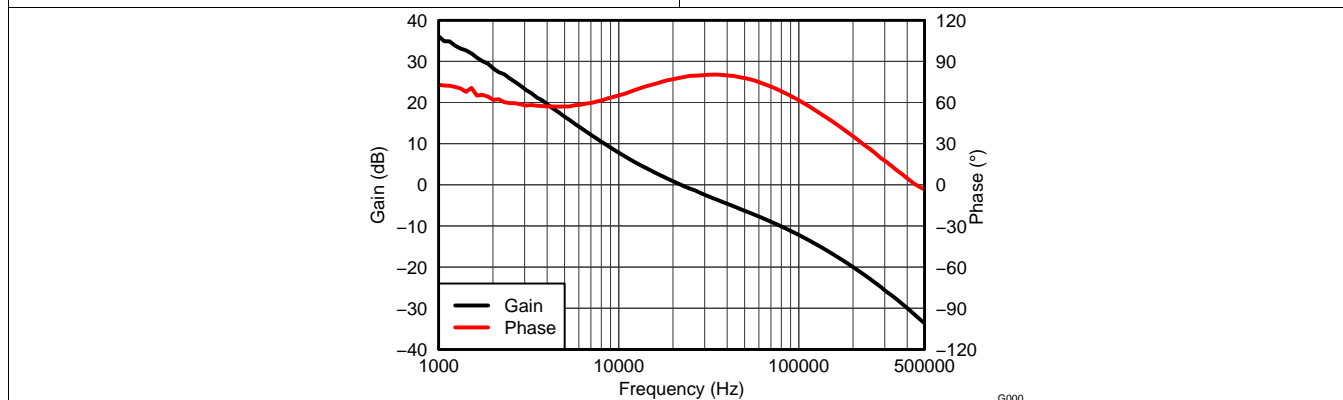

Figure 10.  $V_{OUT} = 1.8\text{ V}$ ,  $I_{OUT} = 6\text{ A}$ ,  $C_{OUT1} = 47\text{ }\mu\text{F}$  ceramic,  $C_{OUT2} = 100\text{ }\mu\text{F}$  POSCAP,  $f_{SW} = 1\text{ MHz}$

## 8 Application Information

### 8.1 Adjusting the Output Voltage

The VADJ control sets the output voltage of the LMZ30606. The output voltage adjustment range is from 0.8V to 3.6V. The adjustment method requires the addition of  $R_{SET}$ , which sets the output voltage, the connection of SENSE+ to VOUT, and in some cases  $R_{RT}$  which sets the switching frequency. The  $R_{SET}$  resistor must be connected directly between the VADJ (pin 35) and AGND (pin 33 & 34). The SENSE+ pin (pin 36) must be connected to VOUT either at the load for improved regulation or at VOUT of the module. The  $R_{RT}$  resistor must be connected directly between the RT/CLK (pin 4) and AGND (pins 33 & 34).

Table 3 gives the standard external  $R_{SET}$  resistor for a number of common bus voltages, along with the recommended  $R_{RT}$  resistor for that output voltage.

**Table 3. Standard  $R_{SET}$  Resistor Values for Common Output Voltages**

RESISTORS	OUTPUT VOLTAGE $V_{OUT}$ (V)					
	0.8	1.2	1.5	1.8	2.5	3.3
$R_{SET}$ (k $\Omega$ )	open	2.87	1.65	1.15	0.673	0.459
$R_{RT}$ (k $\Omega$ )	1200	715	348	348	348	348

For other output voltages, the value of the required resistor can either be calculated using the following formula, or simply selected from the range of values given in Table 4.

$$R_{SET} = \frac{1.43}{\left(\left(\frac{V_{OUT}}{0.799}\right) - 1\right)} \text{ (k}\Omega\text{)}$$

(1)

**Table 4. Standard  $R_{SET}$  Resistor Values**

$V_{OUT}$ (V)	$R_{SET}$ (k $\Omega$ )	$R_{RT}$ (k $\Omega$ )	$f_{SW}$ (kHz)	$V_{OUT}$ (V)	$R_{SET}$ (k $\Omega$ )	$R_{RT}$ (k $\Omega$ )	$f_{SW}$ (kHz)
0.8	open	1200	650	2.3	0.768	348	1000
0.9	11.8	1200	650	2.4	0.715	348	1000
1.0	5.83	1200	650	2.5	0.673	348	1000
1.1	3.83	1200	650	2.6	0.634	348	1000
1.2	2.87	715	750	2.7	0.604	348	1000
1.3	2.32	715	750	2.8	0.576	348	1000
1.4	1.91	715	750	2.9	0.549	348	1000
1.5	1.65	348	1000	3.0	0.523	348	1000
1.6	1.43	348	1000	3.1	0.499	348	1000
1.7	1.27	348	1000	3.2	0.475	348	1000
1.8	1.15	348	1000	3.3	0.459	348	1000
1.9	1.05	348	1000	3.4	0.442	348	1000
2.0	0.953	348	1000	3.5	0.422	348	1000
2.1	0.845	348	1000	3.6	0.412	348	1000
2.2	0.825	348	1000				

## 8.2 Capacitor Recommendations for the LMZ30606 Power Supply

### 8.2.1 Capacitor Technologies

#### 8.2.1.1 Electrolytic, Polymer-Electrolytic Capacitors

When using electrolytic capacitors, high-quality, computer-grade electrolytic capacitors are recommended. Polymer-electrolytic type capacitors are recommended for applications where the ambient operating temperature is less than 0°C. The Sanyo OS-CON capacitor series is suggested due to the lower ESR, higher rated surge, power dissipation, ripple current capability, and small package size. Aluminum electrolytic capacitors provide adequate decoupling over the frequency range of 2 kHz to 150 kHz, and are suitable when ambient temperatures are above 0°C.

#### 8.2.1.2 Ceramic Capacitors

The performance of aluminum electrolytic capacitors is less effective than ceramic capacitors above 150 kHz. Multilayer ceramic capacitors have a low ESR and a resonant frequency higher than the bandwidth of the regulator. They can be used to reduce the reflected ripple current at the input as well as improve the transient response of the output.

#### 8.2.1.3 Tantalum, Polymer-Tantalum Capacitors

Polymer-tantalum type capacitors are recommended for applications where the ambient operating temperature is less than 0°C. The Sanyo POSCAP series and Kemet T530 capacitor series are recommended rather than many other tantalum types due to their lower ESR, higher rated surge, power dissipation, ripple current capability, and small package size. Tantalum capacitors that have no stated ESR or surge current rating are not recommended for power applications.

### 8.2.2 Input Capacitor

The LMZ30606 requires a minimum input capacitance of 47  $\mu\text{F}$  of ceramic capacitance. An additional 220  $\mu\text{F}$  polymer-tantalum capacitor is recommended for applications with transient load requirements. The combined ripple current rating of the input capacitors must be at least 3000 mArms. [Table 6](#) includes a preferred list of capacitors by vendor. For applications where the ambient operating temperature is less than 0°C, an additional 1  $\mu\text{F}$ , X5R or X7R ceramic capacitor placed between VIN and AGND is recommended.

### 8.2.3 Output Capacitor

The required output capacitance is determined by the output voltage of the LMZ30606. See [Table 5](#) for the amount of required capacitance. The required output capacitance must include at least one 47  $\mu\text{F}$  ceramic capacitor. For applications where the ambient operating temperature is less than 0°C, an additional 100  $\mu\text{F}$  polymer-tantalum capacitor is recommended. When adding additional non-ceramic bulk capacitors, low-ESR devices like the ones recommended in [Table 6](#) are required. The required capacitance above the minimum is determined by actual transient deviation requirements. See [Table 7](#) for typical transient response values for several output voltage, input voltage and capacitance combinations. [Table 6](#) includes a preferred list of capacitors by vendor.

**Table 5. Required Output Capacitance**

V <sub>OUT</sub> RANGE (V)		MINIMUM REQUIRED C <sub>OUT</sub> ( $\mu\text{F}$ )
MIN	MAX	
0.8	< 1.8	147 <sup>(1)</sup>
1.8	< 3.3	100 <sup>(2)</sup>
3.3	3.6	47 <sup>(2)</sup>

(1) Minimum required must include at least 1 x 47  $\mu\text{F}$  ceramic capacitor plus 1 x 100  $\mu\text{F}$  polymer-tantalum capacitor.

(2) Minimum required must include at least 47  $\mu\text{F}$  of ceramic capacitance.

**Table 6. Recommended Input/Output Capacitors<sup>(1)</sup>**

VENDOR	SERIES	PART NUMBER	CAPACITOR CHARACTERISTICS		
			WORKING VOLTAGE (V)	CAPACITANCE (μF)	ESR <sup>(2)</sup> (mΩ)
Murata	X5R	GRM32ER61C476K	16	47	2
TDK	X5R	C3225X5R0J107M	6.3	100	2
Murata	X5R	GRM32ER60J107M	6.3	100	2
TDK	X5R	C3225X5R0J476K	6.3	47	2
Murata	X5R	GRM32ER60J476M	6.3	47	2
Sanyo	POSCAP	10TPE220ML	10	220	25
Kemet	T520	T520V107M010ASE025	10	100	25
Sanyo	POSCAP	6TPE100MPB	6.3	100	25
Sanyo	POSCAP	2R5TPE220M7	2.5	220	7
Kemet	T530	T530D227M006ATE006	6.3	220	6
Kemet	T530	T530D337M006ATE010	6.3	330	10
Sanyo	POSCAP	2TPF330M6	2.0	330	6
Sanyo	POSCAP	6TPE330MFL	6.3	330	15

**(1) Capacitor Supplier Verification**

Please verify availability of capacitors identified in this table.

**RoHS, Lead-free and Material Details**

Please consult capacitor suppliers regarding material composition, RoHS status, lead-free status, and manufacturing process requirements.

**(2) Maximum ESR @ 100kHz, 25°C.**
**8.3 Transient Response**
**Table 7. Output Voltage Transient Response**

C <sub>IN1</sub> = 1 x 47 μF CERAMIC, C <sub>IN2</sub> = 220 μF POLYMER-TANTALUM						
V <sub>OUT</sub> (V)	V <sub>IN</sub> (V)	C <sub>OUT1</sub> Ceramic	C <sub>OUT2</sub> BULK	VOLTAGE DEVIATION (mV)		RECOVERY TIME (μs)
				2 A LOAD STEP, (1 A/μs)	3 A LOAD STEP, (1 A/μs)	
0.8	3.3	47 μF	330 μF	35	45	60
		47 μF	470 μF	30	40	60
	5	47 μF	330 μF	30	40	60
		47 μF	470 μF	25	35	60
1.2	3.3	47 μF	330 μF	45	65	60
		47 μF	470 μF	40	60	60
	5	47 μF	330 μF	40	65	60
		47 μF	470 μF	35	60	60
1.8	3.3	47 μF	220 μF	65	90	70
		47 μF	330 μF	60	85	70
	5	47 μF	220 μF	60	85	70
		47 μF	330 μF	50	75	70
2.5	5	3x 47 μF	-	95	150	70
		3x 47 μF	100 μF	85	125	70
3.3	5	3x 47 μF	-	120	180	70
		3x 47 μF	100 μF	100	150	70

### 8.3.1 Transient Waveforms

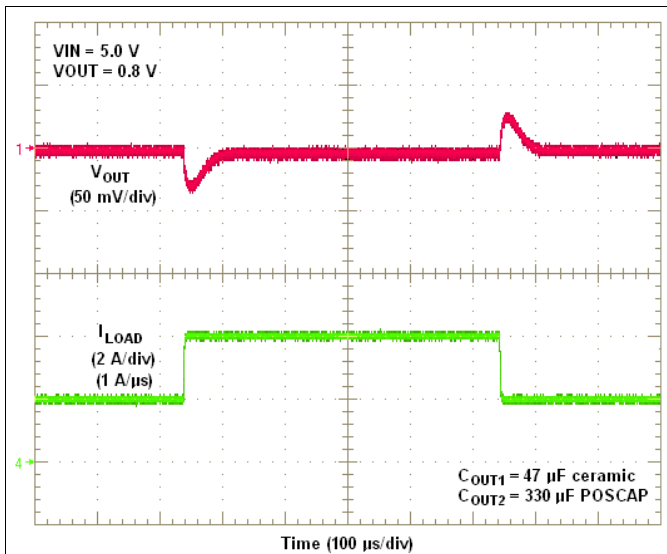

Figure 11. VIN = 5V, VOUT = 0.8V, 2A Load Step

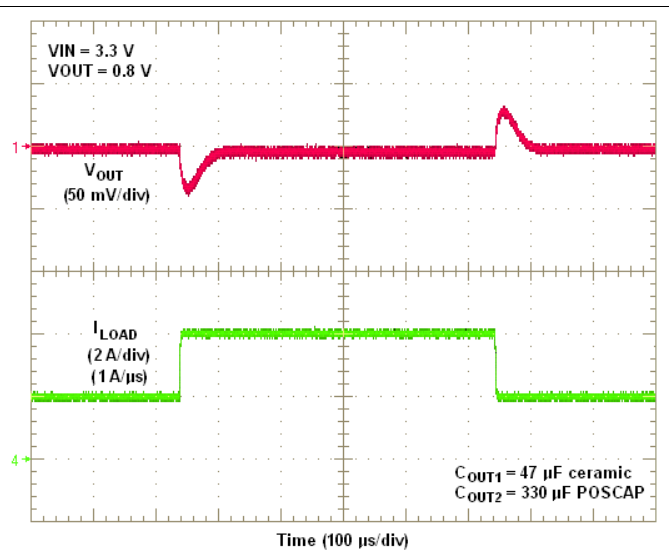

Figure 12. VIN = 3.3V, VOUT = 0.8V, 2A Load Step

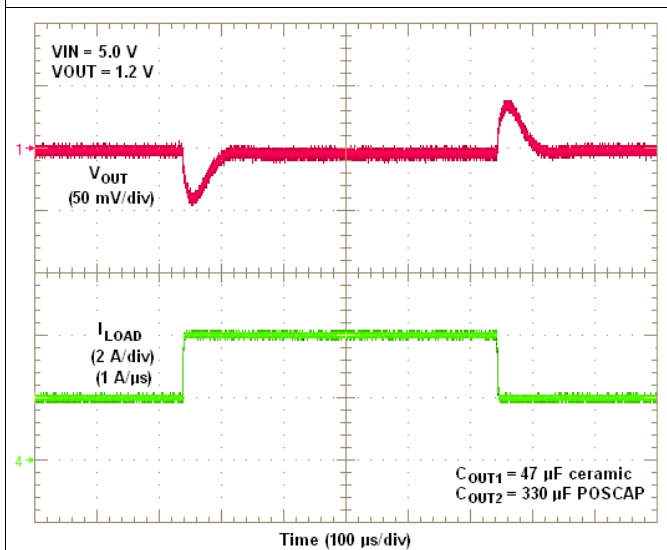

Figure 13. VIN = 5V, VOUT = 1.2V, 2A Load Step

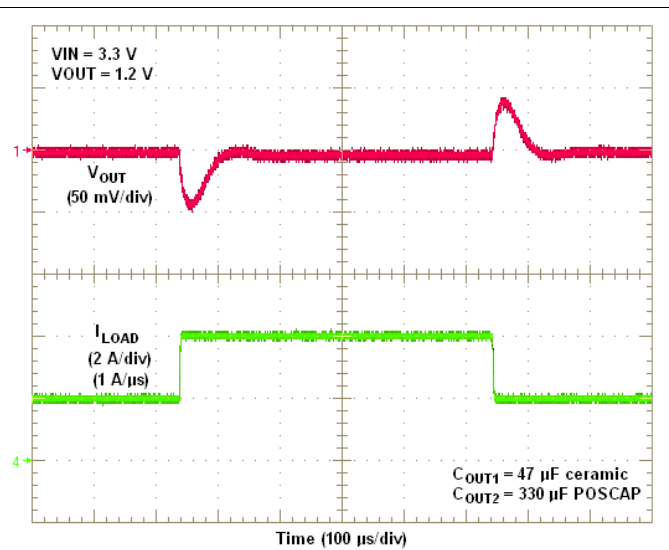
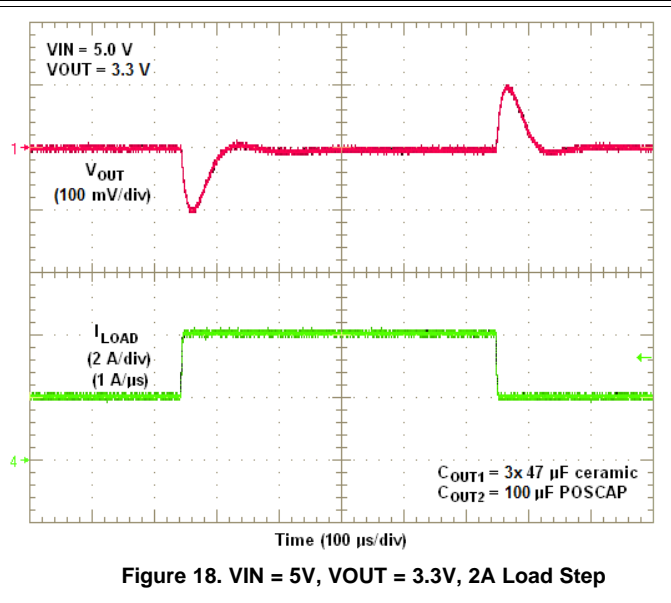
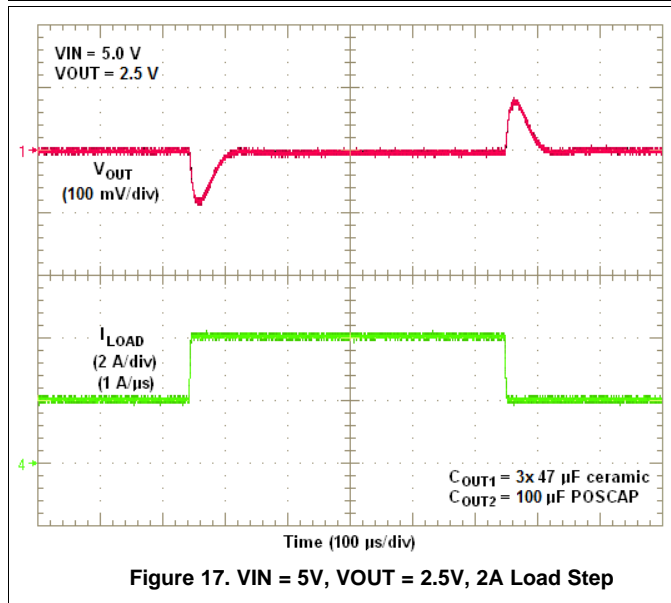
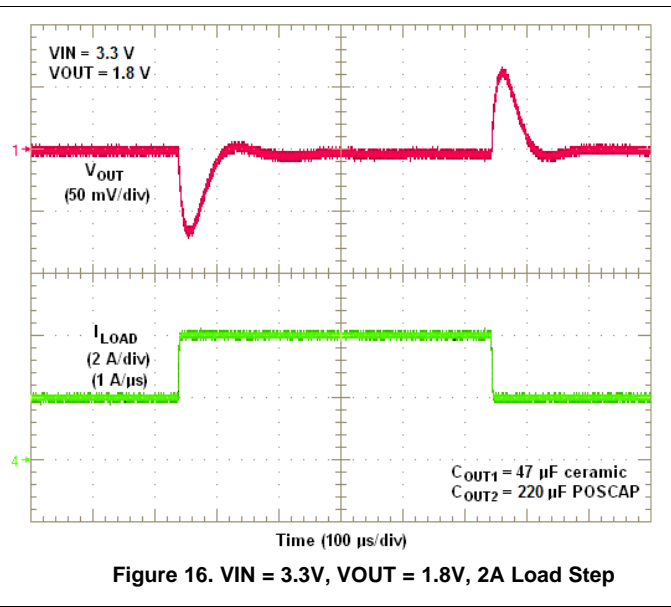
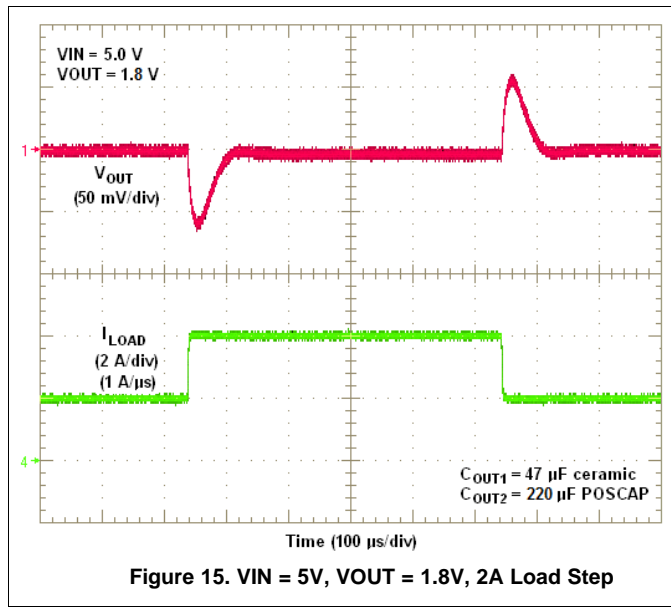
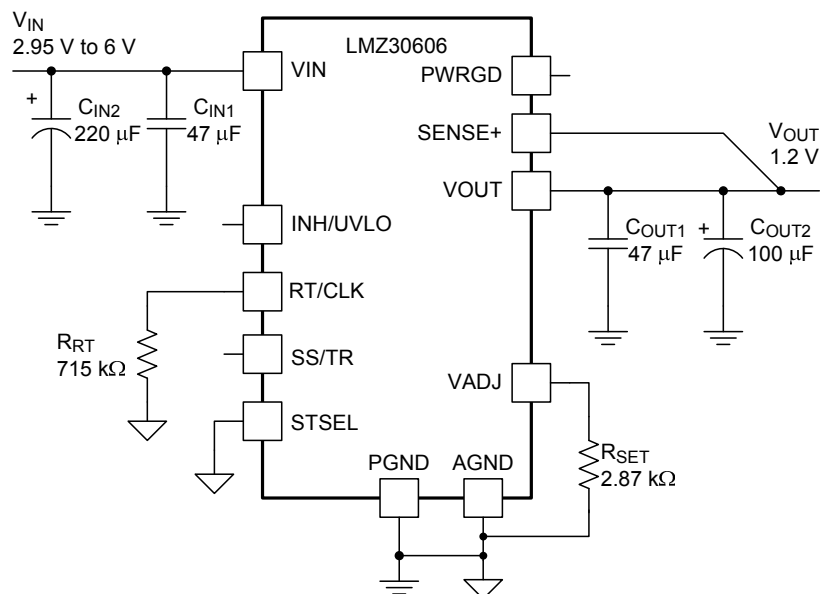

Figure 14. VIN = 3.3V, VOUT = 1.2V, 2A Load Step



## 8.4 Application Schematics



**Figure 19. Typical Schematic**  
 **$V_{IN} = 2.95\text{ V to }6.0\text{ V}$ ,  $V_{OUT} = 1.2\text{ V}$**

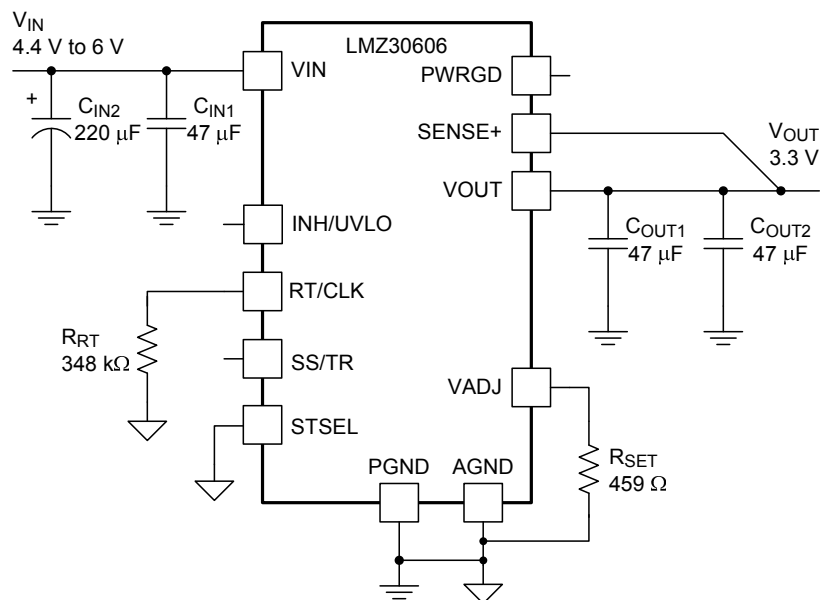

**Figure 20. Typical Schematic**  
 **$V_{IN} = 4.4\text{ V to }6.0\text{ V}$ ,  $V_{OUT} = 3.3\text{ V}$**

## 8.5 Custom Design With WEBENCH® Tools

[Click here](#) to create a custom design using the LMZ30606 device with the WEBENCH® Power Designer.

1. Start by entering the input voltage ( $V_{IN}$ ), output voltage ( $V_{OUT}$ ), and output current ( $I_{OUT}$ ) requirements.
2. Optimize the design for key parameters such as efficiency, footprint, and cost using the optimizer dial.
3. Compare the generated design with other possible solutions from Texas Instruments.

The WEBENCH Power Designer provides a customized schematic along with a list of materials with real-time pricing and component availability.

In most cases, these actions are available:

- Run electrical simulations to see important waveforms and circuit performance
- Run thermal simulations to understand board thermal performance
- Export customized schematic and layout into popular CAD formats
- Print PDF reports for the design, and share the design with colleagues

Get more information about WEBENCH tools at [www.ti.com/WEBENCH](http://www.ti.com/WEBENCH).

## 8.6 Power Good (PWRGD)

The PWRGD pin is an open drain output. Once the voltage on the SENSE+ pin is between 93% and 107% of the set voltage, the PWRGD pin pull-down is released and the pin floats. The recommended pull-up resistor value is between 10 k $\Omega$  and 100 k $\Omega$  to a voltage source that is 6 V or less. The PWRGD pin is in a defined state once  $V_{IN}$  is greater than 1.2 V, but with reduced current sinking capability. The PWRGD pin achieves full current sinking capability once the  $V_{IN}$  pin is above 2.95V. [Figure 21](#) shows the PWRGD waveform during power-up. The PWRGD pin is pulled low when the voltage on SENSE+ is lower than 91% or greater than 109% of the nominal set voltage. Also, the PWRGD pin is pulled low if the input UVLO or thermal shutdown is asserted, or if the INH pin is pulled low.



## 8.7 Power-Up Characteristics

When configured as shown in the front page schematic, the LMZ30606 produces a regulated output voltage following the application of a valid input voltage. During the power-up, internal soft-start circuitry slows the rate that the output voltage rises, thereby limiting the amount of in-rush current that can be drawn from the input source. The soft-start circuitry introduces a short time delay from the point that a valid input voltage is recognized. Figure 21 shows the start-up waveforms for a LMZ30606, operating from a 5-V input and with the output voltage adjusted to 1.8 V. The waveform is measured with a 3-A constant current load.

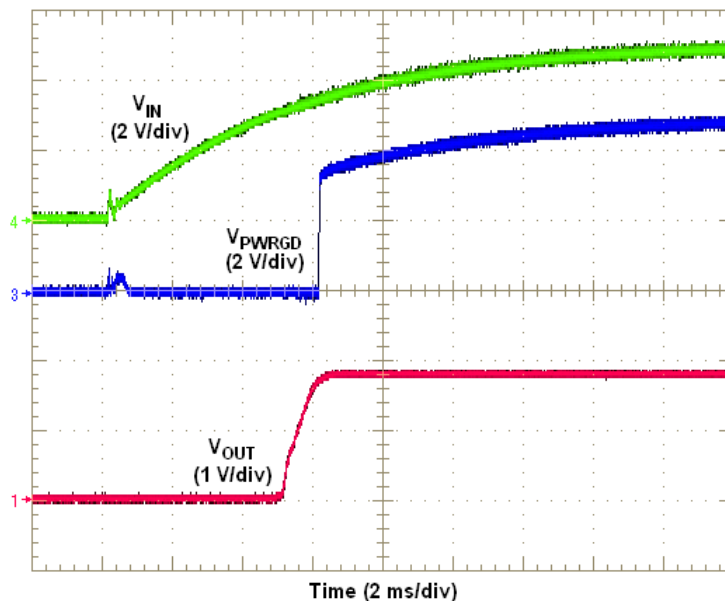

**Figure 21. Start-Up Waveforms**

## 8.8 Remote Sense

The SENSE+ pin must be connected to  $V_{OUT}$  at the load, or at the device pins.

Connecting the SENSE+ pin to  $V_{OUT}$  at the load improves the load regulation performance of the device by allowing it to compensate for any I-R voltage drop between its output pins and the load. An I-R drop is caused by the high output current flowing through the small amount of pin and trace resistance. This should be limited to a maximum of 300 mV.

---

### NOTE

The remote sense feature is not designed to compensate for the forward drop of nonlinear or frequency dependent components that may be placed in series with the converter output. Examples include OR-ing diodes, filter inductors, ferrite beads, and fuses. When these components are enclosed by the SENSE+ connection, they are effectively placed inside the regulation control loop, which can adversely affect the stability of the regulator.

---

## 8.9 Output On/Off Inhibit (INH)

The INH pin provides electrical on/off control of the device. Once the INH pin voltage exceeds the threshold voltage, the device starts operation. If the INH pin voltage is pulled below the threshold voltage, the regulator stops switching and enters low quiescent current state.

The INH pin has an internal pull-up current source, allowing the user to float the INH pin for enabling the device. If an application requires controlling the INH pin, use an open drain/collector device, or a suitable logic gate to interface with the pin. Do not place an external pull-up resistor on this pin. Figure 22 shows the typical application of the inhibit function.

Turning Q1 on applies a low voltage to the inhibit control (INH) pin and disables the output of the supply, as shown in Figure 23. If Q1 is turned off, the supply executes a soft-start power-up sequence, as shown in Figure 24. The waveforms were measured with a 3-A constant current load.

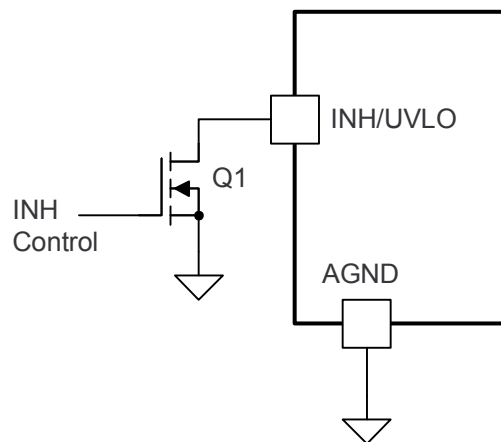

**Figure 22. Typical Inhibit Control**

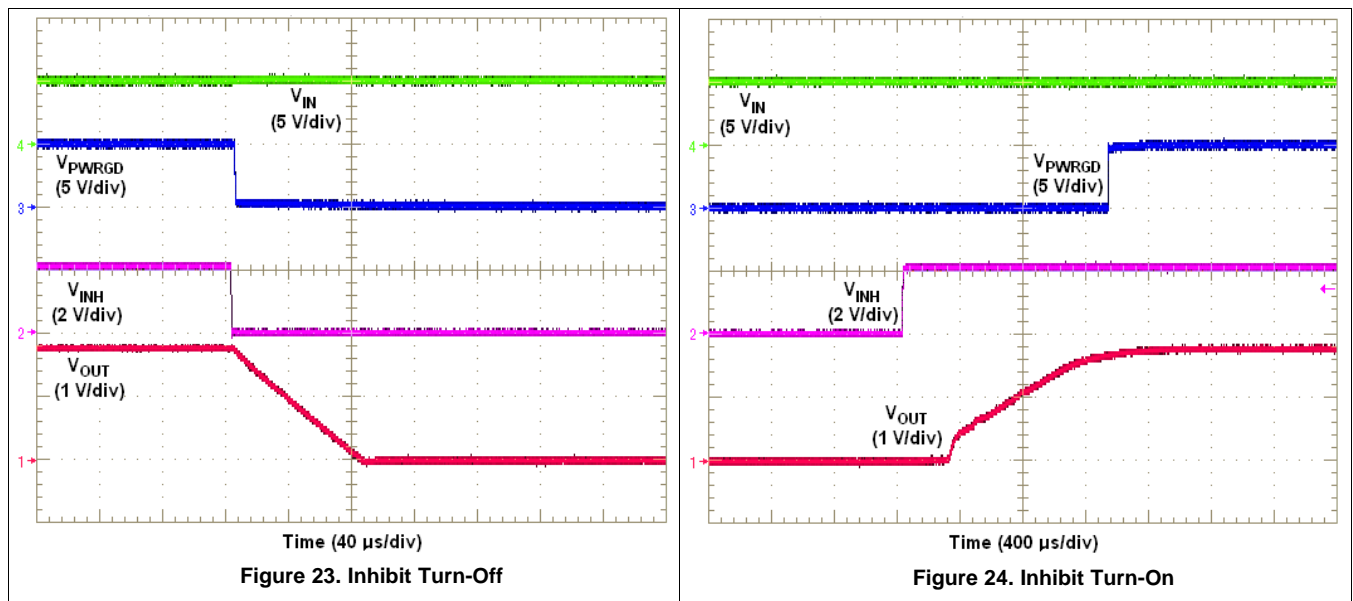

### 8.10 Slow Start (SS/TR)

Connecting the STSEL pin to AGND and leaving SS/TR pin open enables the internal SS capacitor with a slow start interval of approximately 1.1 ms. Adding additional capacitance between the SS pin and AGND increases the slow start time. Table 8 shows an additional SS capacitor connected to the SS/TR pin and the STSEL pin connected to AGND. See Table 8 below for SS capacitor values and timing interval.

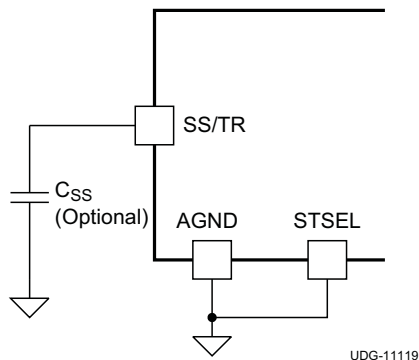

Figure 25. Slow-Start Capacitor (C<sub>SS</sub>) and STSEL Connection

Table 8. Slow-Start Capacitor Values and Slow-Start Time

C <sub>SS</sub> (pF)	open	2200	4700	10000	15000	22000	25000
SS Time (msec)	1.1	1.9	2.8	4.6	6.4	8.8	9.8

### 8.11 Overcurrent Protection

For protection against load faults, the LMZ30606 uses current limiting. The device is protected from overcurrent conditions by cycle-by-cycle current limiting and frequency foldback. During an overcurrent condition the output current is limited and the output voltage is reduced, as shown in Figure 26. When the overcurrent condition is removed, the output voltage returns to the established voltage, as shown in Figure 27.

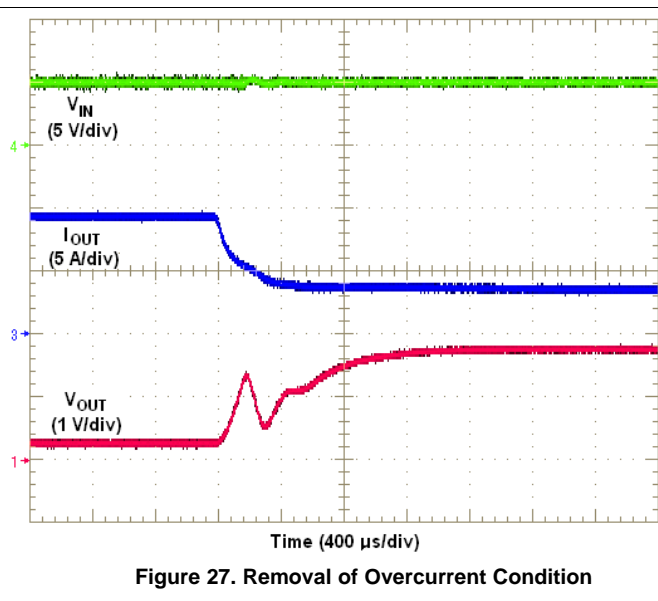
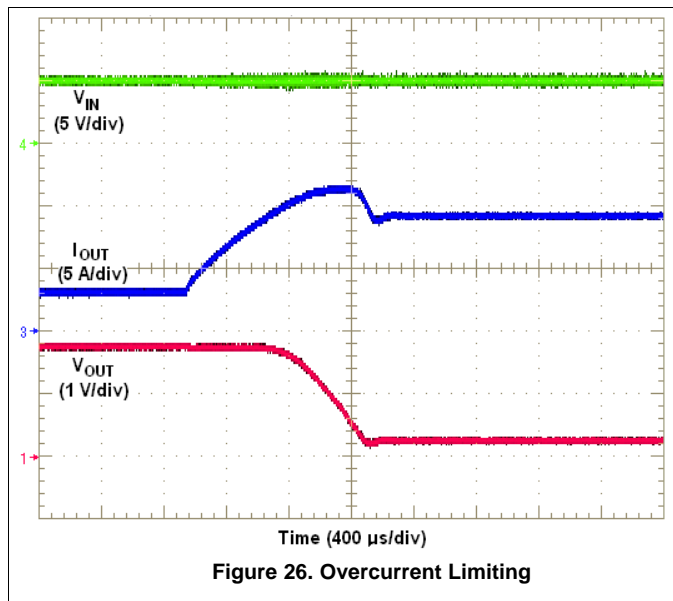

### 8.12 Synchronization (CLK)

An internal phase locked loop (PLL) has been implemented to allow synchronization between 500 kHz and 2 MHz, and to easily switch from RT mode to CLK mode. To implement the synchronization feature, connect a square wave clock signal to the RT/CLK pin with a minimum pulse width of 75 ns. The maximum clock pulse width must be calculated using Equation 2. The clock signal amplitude must transition lower than 0.4 V and higher than 2.2 V. The start of the switching cycle is synchronized to the falling edge of RT/CLK pin. Applications requiring both RT mode and CLK mode, configure the device as shown in Figure 28.

Before the external clock is present, the device works in RT mode and the switching frequency is set by the RT resistor (R<sub>RT</sub>). When the external clock is present, the CLK mode overrides the RT mode. The device switches from RT mode to CLK mode and the RT/CLK pin becomes high impedance as the PLL starts to lock onto the frequency of the external clock. The device will lock to the external clock frequency approximately 15 μs after a valid clock signal is present. It is not recommended to switch from CLK mode back to RT mode because the internal switching frequency drops to a lower frequency before returning to the switching frequency set by the RT resistor.

$$CLK\_PW_{MAX} = \frac{0.75 \times \left( 1 - \frac{V_{OUT}}{V_{IN(min)}} \right)}{f_{SW}} \quad (2)$$

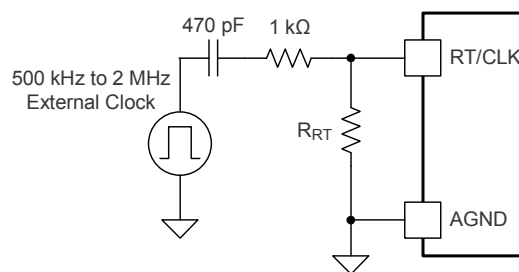

Figure 28. CLK/RT Configuration

Select the synchronization frequency based on the output voltages of the devices being synchronized. Table 9 shows the allowable V<sub>OUT</sub> range for a given switching frequency when operating from a typical 5 V bus and a typical 3.3 V bus. For the most optimal solution, synchronize to a frequency in the center of the allowable frequency range. For example, an application requires synchronizing three LMZ30606 devices with output voltages of 1.2V, 1.8V, and 3.3V, all powered from V<sub>IN</sub> = 5V. Table 9 shows that all three output voltages can be synchronized to any frequency between 600 kHz to 1 MHz. For the most optimal solution, choose 800 kHz as the synchronization frequency. (Values included in the table are based on a resistive load.)

Table 9. Synchronization Frequency vs Output Voltage

SYNCHRONIZATION FREQUENCY (kHz)	R <sub>RT</sub> (kΩ)	VIN = 5V (+/- 10%)		VIN = 3.3V (+/- 5%)	
		V <sub>OUT</sub> RANGE (V)		V <sub>OUT</sub> RANGE (V)	
		MIN	MAX	MIN	MAX
500	open	0.8	1.8	0.8	2.5
550	3400	0.8	2.2	0.8	2.5
600	1800	0.8	3.3	0.8	2.5
650	1200	0.8	3.6	0.8	2.5
700	887	0.8	3.6	0.8	2.5
750	715	0.9	3.6	0.8	2.5
800	590	0.9	3.6	0.8	2.5
850	511	1.0	3.6	0.8	2.5
900	442	1.0	3.6	0.8	2.5
950	392	1.1	3.6	0.8	2.5
1000	348	1.1	3.6	0.8	2.5
1250	232	1.4	3.6	0.9	2.4
1500	174	1.7	3.5	1.1	2.3
1750	137	2.0	3.4	1.3	2.3

Table 9. Synchronization Frequency vs Output Voltage (continued)

SYNCHRONIZATION FREQUENCY (kHz)	R <sub>RT</sub> (kΩ)	VIN = 5V (+/- 10%)		VIN = 3.3V (+/- 5%)	
		V <sub>OUT</sub> RANGE (V)		V <sub>OUT</sub> RANGE (V)	
		MIN	MAX	MIN	MAX
2000	113	2.2	3.3	1.4	2.2

### 8.13 Sequencing (SS/TR)

Many of the common power supply sequencing methods can be implemented using the SS/TR, INH and PWRGD pins. The sequential method is illustrated in Figure 29 using two LMZ30606 devices. The PWRGD pin of the first device is coupled to the INH pin of the second device which enables the second power supply once the primary supply reaches regulation. Figure 30 shows sequential turn-on waveforms of two LMZ30606 devices.

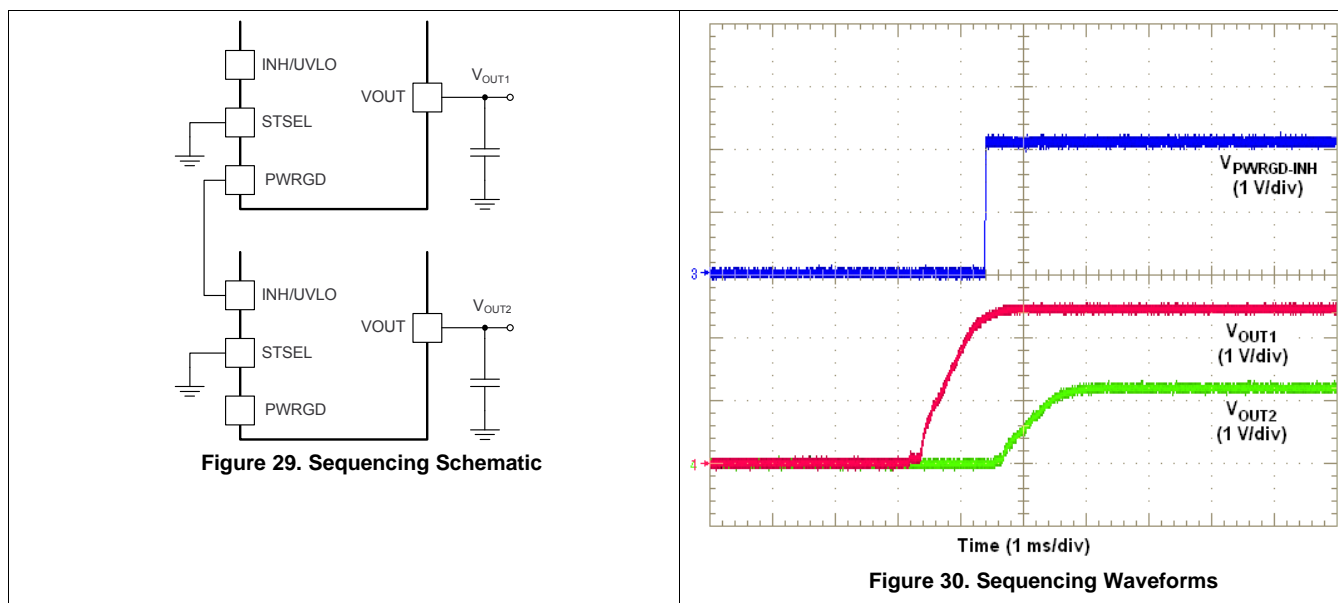

Simultaneous power supply sequencing can be implemented by connecting the resistor network of R1 and R2 shown in Figure 31 to the output of the power supply that needs to be tracked or to another voltage reference source. Figure 32 shows simultaneous turn-on waveforms of two LMZ30606 devices. Use Equation 3 and Equation 4 to calculate the values of R1 and R2.

$$R1 = \frac{(V_{OUT2} \times 12.6)}{0.799} \text{ (k}\Omega\text{)}$$

(3)

$$R2 = \frac{0.799 \times R1}{(V_{OUT2} - 0.799)} \text{ (k}\Omega\text{)}$$

(4)

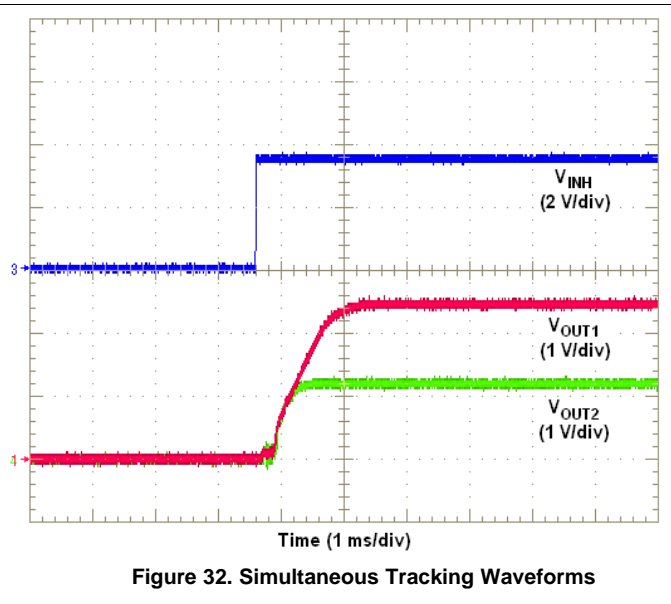
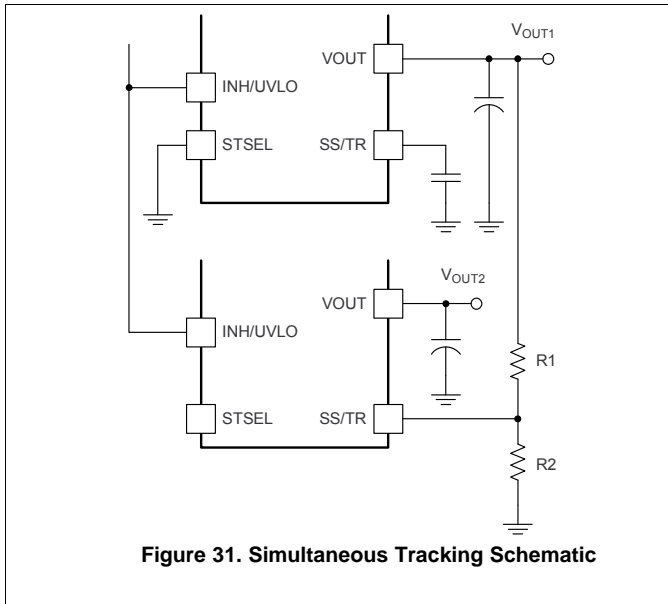

### 8.14 Programmable Undervoltage Lockout (UVLO)

The LMZ30606 implements internal UVLO circuitry on the VIN pin. The device is disabled when the VIN pin voltage falls below the internal VIN UVLO threshold. The internal VIN UVLO rising threshold is 3.135 V(max) with a typical hysteresis of 300 mV.

If an application requires a higher UVLO threshold on the VIN pin, the UVLO pin can be configured as shown in [Figure 33](#). [Table 10](#) lists standard values for  $R_{UVLO}$  to adjust the VIN UVLO voltage up.

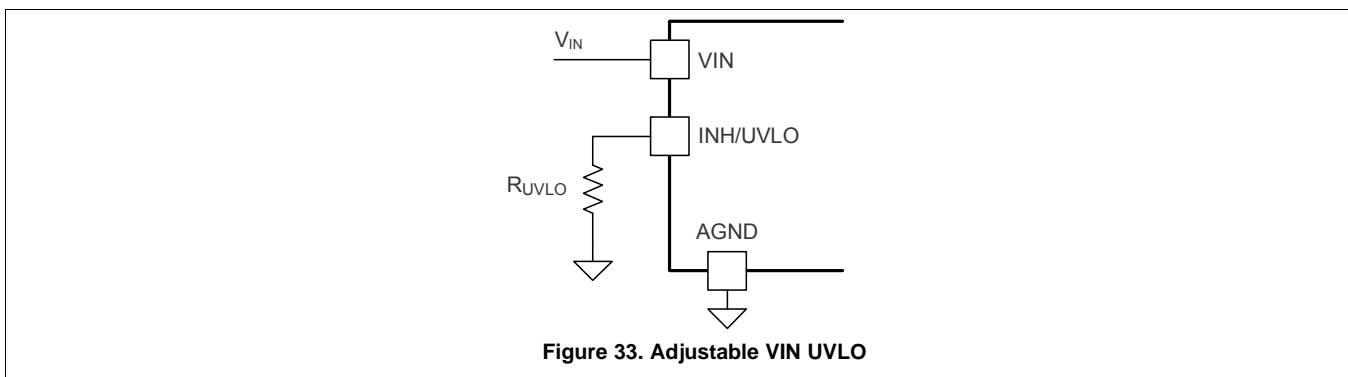

**Table 10. Standard Resistor values for Adjusting VIN UVLO**

VIN UVLO (V) (typ)	3.25	3.5	3.75	4.0	4.25	4.5	4.75
$R_{UVLO}$ (k $\Omega$ )	294	133	86.6	63.4	49.9	42.2	35.7
Hysteresis (mV)	325	335	345	355	365	375	385

### 8.15 Thermal Shutdown

The internal thermal shutdown circuitry forces the device to stop switching if the junction temperature exceeds 170°C typically. The device reinitiates the power up sequence when the junction temperature drops below 150°C typically.

### 8.16 EMI

The LMZ30606 is compliant with EN55022 Class B radiated emissions. [Figure 34](#) and [Figure 35](#) show typical examples of radiated emissions plots for the LMZ30606 operating from 5V and 3.3V respectively. Both graphs include the plots of the antenna in the horizontal and vertical positions.

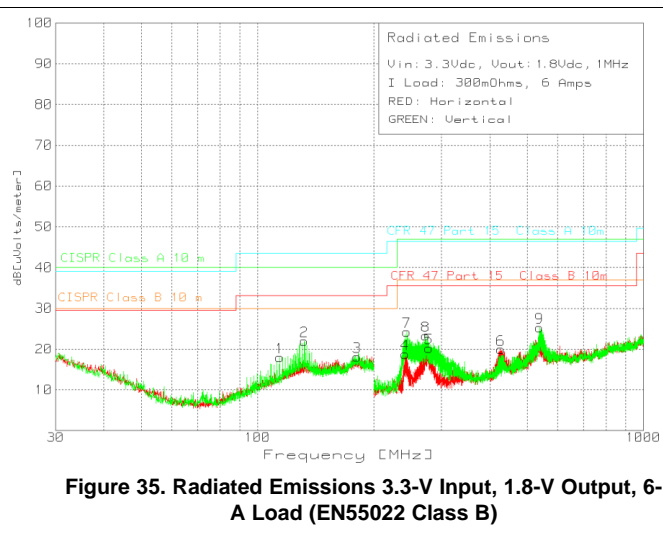
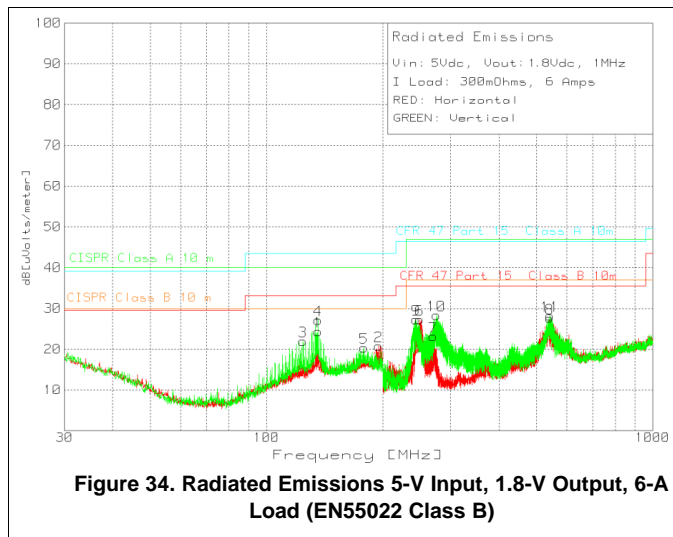

## 8.17 Layout Considerations

To achieve optimal electrical and thermal performance, an optimized PCB layout is required. Figure 36, shows a typical PCB layout. Some considerations for an optimized layout are:

- Use large copper areas for power planes (VIN, VOUT, and PGND) to minimize conduction loss and thermal stress.
- Place ceramic input and output capacitors close to the module pins to minimize high frequency noise.
- Locate additional output capacitors between the ceramic capacitor and the load.
- Place a dedicated AGND copper area beneath the LMZ30606.
- Connect the AGND and PGND copper area at one point; directly at the pin 37 PowerPad using multiple vias.
- Place  $R_{SET}$ ,  $R_{RT}$ , and  $C_{SS}$  as close as possible to their respective pins.
- Use multiple vias to connect the power planes to internal layers.

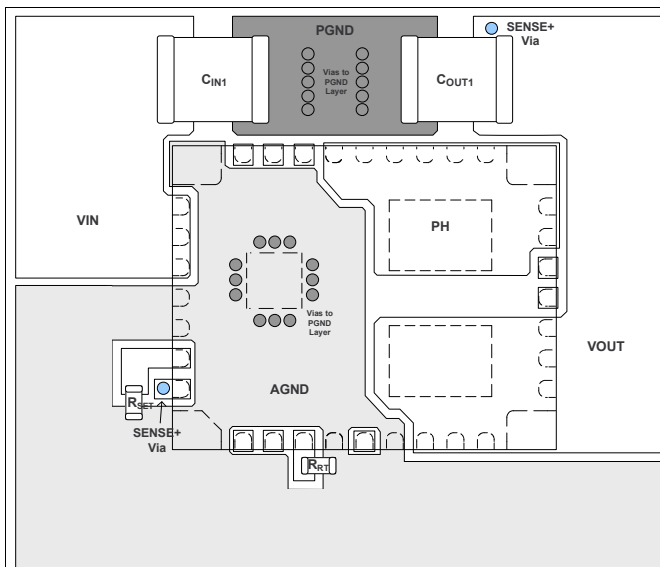

Figure 36. Typical Top-Layer Recommended Layout

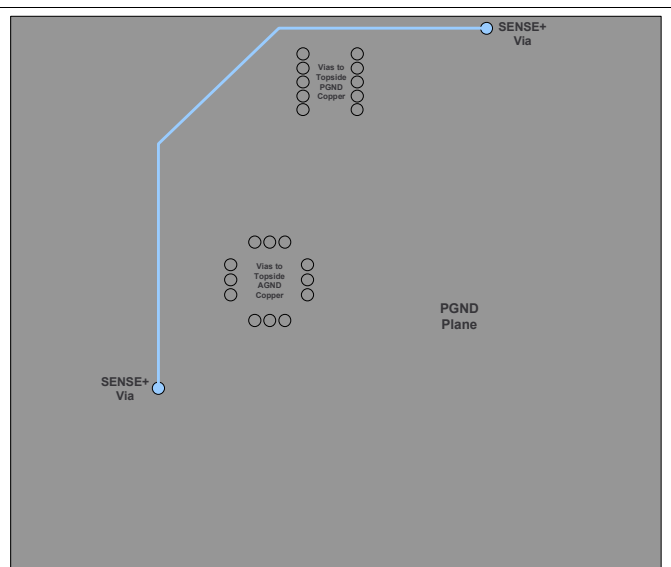

Figure 37. Typical PGND-Layer Recommended Layout



## 9 Revision History

NOTE: Page numbers for previous revisions may differ from page numbers in the current version.

<b>Changes from Revision A (June 2017) to Revision B</b>	<b>Page</b>
• 添加 LMZ30606 的 WEBENCH® 设计链接 .....	1
• Increased the peak reflow temperature and maximum number of reflows to JEDEC specifications for improved manufacturability .....	2
• 添加器件和文档支持 部分 .....	26
• 添加机械、封装和可订购信息 部分 .....	26

---

<b>Changes from Original (July 2013) to Revision A</b>	<b>Page</b>
• Added peak reflow and maximum number of reflows information .....	2

## 10 器件和文档支持

### 10.1 器件支持

#### 10.1.1 开发支持

##### 10.1.1.1 使用 **WEBENCH®** 工具创建定制设计

单击[此处](#)，使用 LMZ30606 器件并借助 WEBENCH® 电源设计器创建定制设计方案。

1. 首先键入输入电压 ( $V_{IN}$ )、输出电压 ( $V_{OUT}$ ) 和输出电流 ( $I_{OUT}$ ) 要求。
2. 使用优化器拨盘优化关键参数设计，如效率、封装和成本。
3. 将生成的设计与德州仪器 (TI) 的其他解决方案进行比较。

WEBENCH 电源设计器可提供定制原理图以及罗列实时价格和组件供货情况的物料清单。

在多数情况下，可执行以下操作：

- 运行电气仿真，观察重要波形以及电路性能
- 运行热性能仿真，了解电路板热性能
- 将定制原理图和布局方案导出至常用 CAD 格式
- 打印设计方案的 PDF 报告并与同事共享

有关 WEBENCH 工具的详细信息，请访问 [www.ti.com.cn/WEBENCH](http://www.ti.com.cn/WEBENCH)。

### 10.2 接收文档更新通知

要接收文档更新通知，请导航至 [TI.com.cn](http://TI.com.cn) 上的器件产品文件夹。单击右上角的 *通知我* 进行注册，即可每周接收产品信息更改摘要。有关更改的详细信息，请查看任何已修订文档中包含的修订历史记录。

### 10.3 社区资源

下列链接提供到 TI 社区资源的连接。链接的内容由各个分销商“按照原样”提供。这些内容并不构成 TI 技术规范，并且不一定反映 TI 的观点；请参阅 TI 的《[使用条款](#)》。

**TI E2E™ 在线社区** *TI 的工程师对工程师 (E2E) 社区*。此社区的创建目的在于促进工程师之间的协作。在 [e2e.ti.com](http://e2e.ti.com) 中，您可以咨询问题、分享知识、拓展思路并与同行工程师一道帮助解决问题。

**设计支持** *TI 参考设计支持* 可帮助您快速查找有帮助的 E2E 论坛、设计支持工具以及技术支持的联系信息。

### 10.4 商标

E2E is a trademark of Texas Instruments.

WEBENCH is a registered trademark of Texas Instruments.

All other trademarks are the property of their respective owners.

### 10.5 静电放电警告



ESD 可能会损坏该集成电路。德州仪器 (TI) 建议通过适当的预防措施处理所有集成电路。如果不遵守正确的处理措施和安装程序，可能会损坏集成电路。

ESD 的损坏小至导致微小的性能降级，大至整个器件故障。精密的集成电路可能更容易受到损坏，这是因为非常细微的参数更改都可能会导致器件与其发布的规格不相符。

### 10.6 术语表

**SLYZ022** — *TI 术语表*。

这份术语表列出并解释术语、缩写和定义。

## 11 机械、封装和可订购信息

以下页面包含机械、封装和可订购信息。这些信息是指定器件的最新可用数据。数据如有变更，恕不另行通知，且不会对此文档进行修订。如需获取此数据表的浏览器版本，请参阅左侧的导航栏。

**PACKAGING INFORMATION**

Orderable Device	Status (1)	Package Type	Package Drawing	Pins	Package Qty	Eco Plan (2)	Lead/Ball Finish (6)	MSL Peak Temp (3)	Op Temp (°C)	Device Marking (4/5)	Samples
LMZ30606RKGR	ACTIVE	B1QFN	RKG	39	500	RoHS Exempt & Green	NIPDAU	Level-3-250C-168 HR	-40 to 85	(54618, LMZ30606)	<a href="#">Samples</a>
LMZ30606RKG	ACTIVE	B1QFN	RKG	39	250	RoHS Exempt & Green	NIPDAU	Level-3-250C-168 HR	-40 to 85	(54618, LMZ30606)	<a href="#">Samples</a>

(1) The marketing status values are defined as follows:

**ACTIVE:** Product device recommended for new designs.

**LIFEBUY:** TI has announced that the device will be discontinued, and a lifetime-buy period is in effect.

**NRND:** Not recommended for new designs. Device is in production to support existing customers, but TI does not recommend using this part in a new design.

**PREVIEW:** Device has been announced but is not in production. Samples may or may not be available.

**OBsolete:** TI has discontinued the production of the device.

(2) **RoHS:** TI defines "RoHS" to mean semiconductor products that are compliant with the current EU RoHS requirements for all 10 RoHS substances, including the requirement that RoHS substance do not exceed 0.1% by weight in homogeneous materials. Where designed to be soldered at high temperatures, "RoHS" products are suitable for use in specified lead-free processes. TI may reference these types of products as "Pb-Free".

**RoHS Exempt:** TI defines "RoHS Exempt" to mean products that contain lead but are compliant with EU RoHS pursuant to a specific EU RoHS exemption.

**Green:** TI defines "Green" to mean the content of Chlorine (Cl) and Bromine (Br) based flame retardants meet JS709B low halogen requirements of <=1000ppm threshold. Antimony trioxide based flame retardants must also meet the <=1000ppm threshold requirement.

(3) MSL, Peak Temp. - The Moisture Sensitivity Level rating according to the JEDEC industry standard classifications, and peak solder temperature.

(4) There may be additional marking, which relates to the logo, the lot trace code information, or the environmental category on the device.

(5) Multiple Device Markings will be inside parentheses. Only one Device Marking contained in parentheses and separated by a "-" will appear on a device. If a line is indented then it is a continuation of the previous line and the two combined represent the entire Device Marking for that device.

(6) Lead/Ball Finish - Orderable Devices may have multiple material finish options. Finish options are separated by a vertical ruled line. Lead/Ball Finish values may wrap to two lines if the finish value exceeds the maximum column width.

**Important Information and Disclaimer:**The information provided on this page represents TI's knowledge and belief as of the date that it is provided. TI bases its knowledge and belief on information provided by third parties, and makes no representation or warranty as to the accuracy of such information. Efforts are underway to better integrate information from third parties. TI has taken and continues to take reasonable steps to provide representative and accurate information but may not have conducted destructive testing or chemical analysis on incoming materials and chemicals. TI and TI suppliers consider certain information to be proprietary, and thus CAS numbers and other limited information may not be available for release.

In no event shall TI's liability arising out of such information exceed the total purchase price of the TI part(s) at issue in this document sold by TI to Customer on an annual basis.

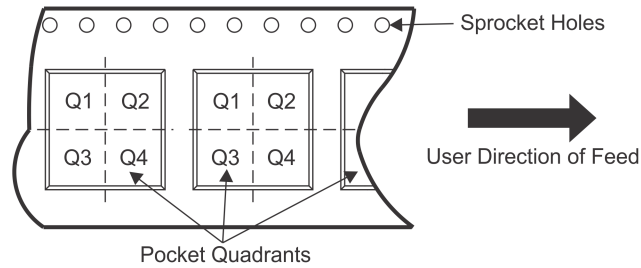

**TAPE AND REEL INFORMATION**

**QUADRANT ASSIGNMENTS FOR PIN 1 ORIENTATION IN TAPE**

\*All dimensions are nominal

Device	Package Type	Package Drawing	Pins	SPQ	Reel Diameter (mm)	Reel Width W1 (mm)	A0 (mm)	B0 (mm)	K0 (mm)	P1 (mm)	W (mm)	Pin1 Quadrant
LMZ30606RKGR	B1QFN	RKG	39	500	330.0	24.4	9.35	11.35	3.1	16.0	24.0	Q1
LMZ30606RKGT	B1QFN	RKG	39	250	330.0	24.4	9.35	11.35	3.1	16.0	24.0	Q1

**TAPE AND REEL BOX DIMENSIONS**



\*All dimensions are nominal

Device	Package Type	Package Drawing	Pins	SPQ	Length (mm)	Width (mm)	Height (mm)
LMZ30606RKGR	B1QFN	RKG	39	500	383.0	353.0	58.0
LMZ30606RKGT	B1QFN	RKG	39	250	383.0	353.0	58.0

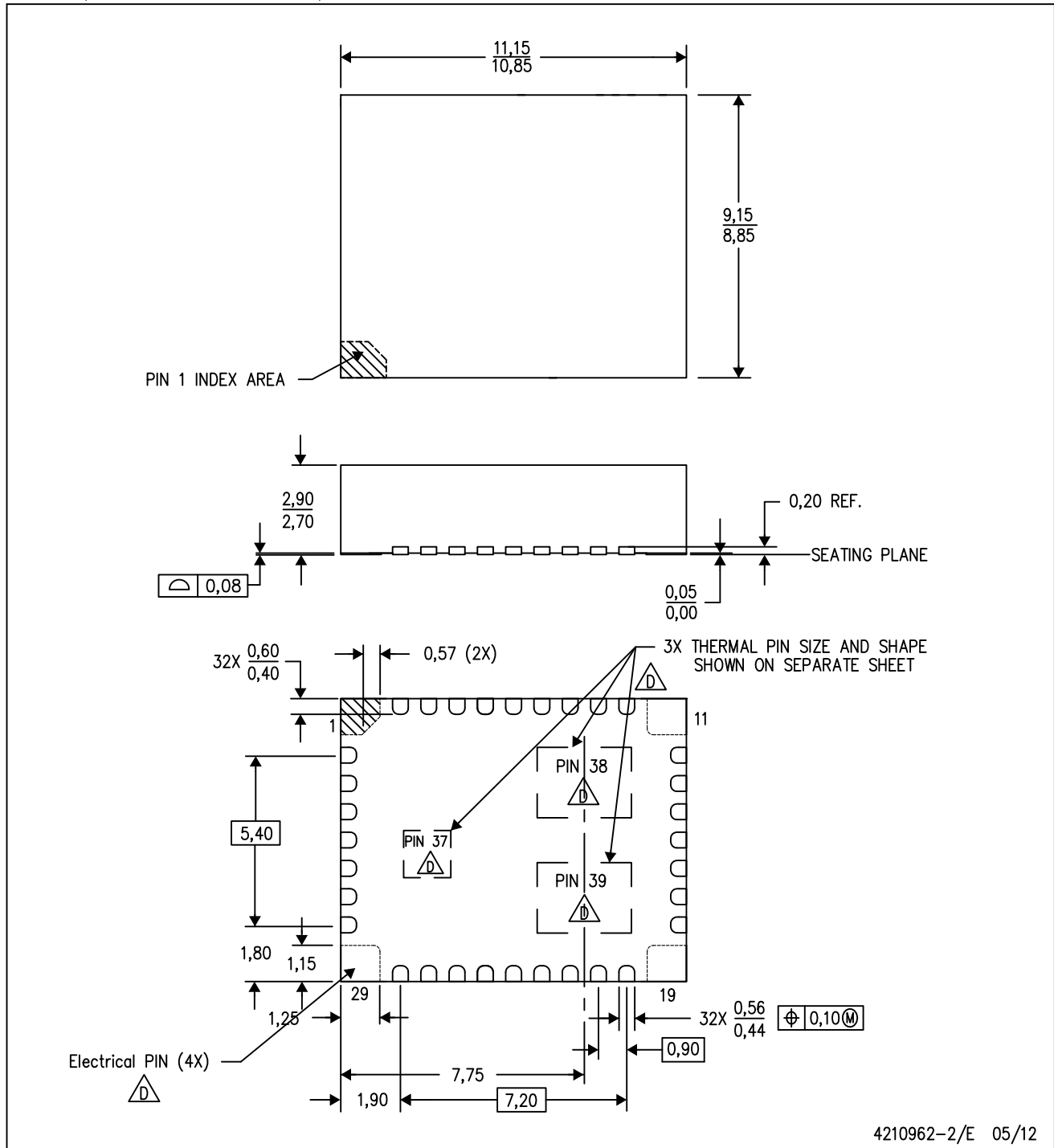

# MECHANICAL DATA

RKG (R-PB1QFN-N39)

PLASTIC QUAD FLATPACK NO-LEAD



4210962-2/E 05/12

- NOTES:
- A. All linear dimensions are in millimeters. Dimensioning and tolerancing per ASME Y14.5M-1994.
  - B. This drawing is subject to change without notice.
  - C. Quad Flatpack, No-leads (QFN) package configuration.
  -  D. The package thermal pad must be soldered to the board for thermal and mechanical performance.
  - E. See the additional figure in the Product Data Sheet for details regarding the exposed thermal pad features and dimensions.
  -  F. The package thermal performance may be enhanced by bonding the thermal pad to an external thermal plane.

RKG (R-PQFN-N39)

PLASTIC QUAD FLATPACK NO-LEAD

**THERMAL INFORMATION**

This package incorporates an exposed thermal pad that is designed to be attached directly to an external heatsink. The thermal pad must be soldered directly to the printed circuit board (PCB). After soldering, the PCB can be used as a heatsink. In addition, through the use of thermal vias, the thermal pad can be attached directly to the appropriate copper plane shown in the electrical schematic for the device, or alternatively, can be attached to a special heatsink structure designed into the PCB. This design optimizes the heat transfer from the integrated circuit (IC).

For information on the Quad Flatpack No-Lead (QFN) package and its advantages, refer to Application Report, QFN/SON PCB Attachment, Texas Instruments Literature No. SLUA271. This document is available at [www.ti.com](http://www.ti.com).

The exposed thermal pad dimensions for this package are shown in the following illustration.

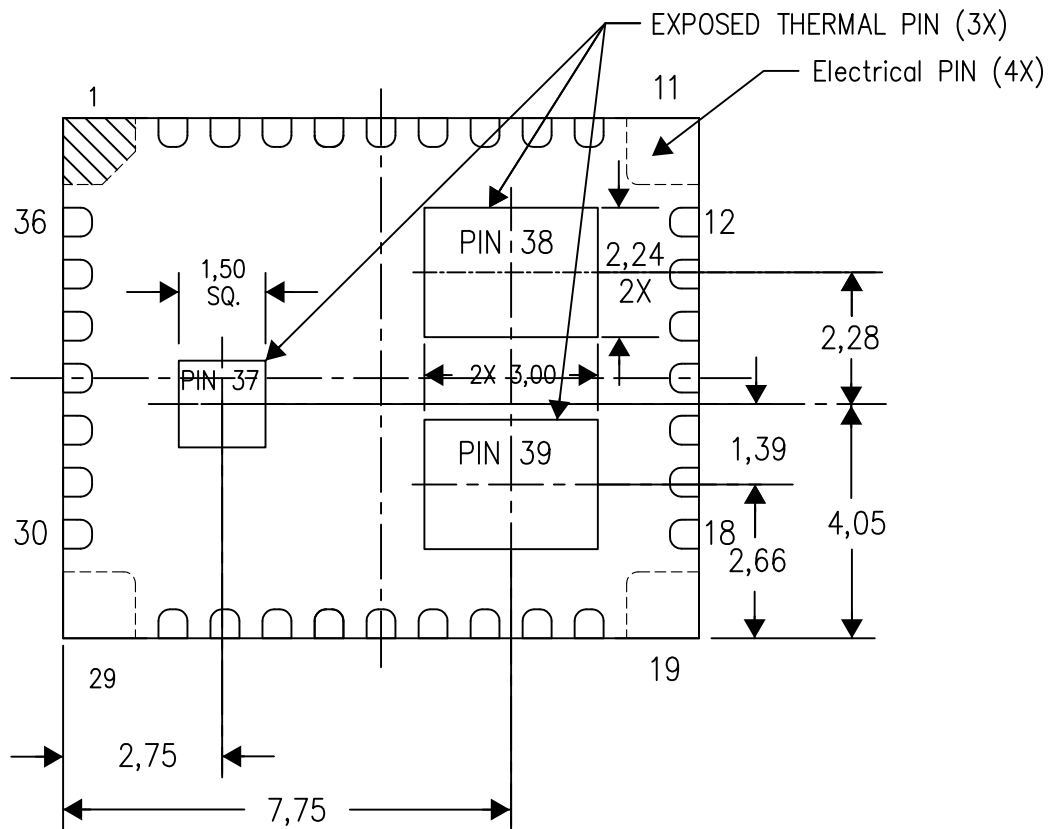

Bottom View

Exposed Thermal Pad Dimensions  
Thermal Pad Tolerance:  $\pm 0.10\text{mm}$

4211170-2/D 01/15

NOTE: A. All linear dimensions are in millimeters



RKG (S-PB1QFN-N39)

PLASTIC QUAD FLATPACK NO-LEAD

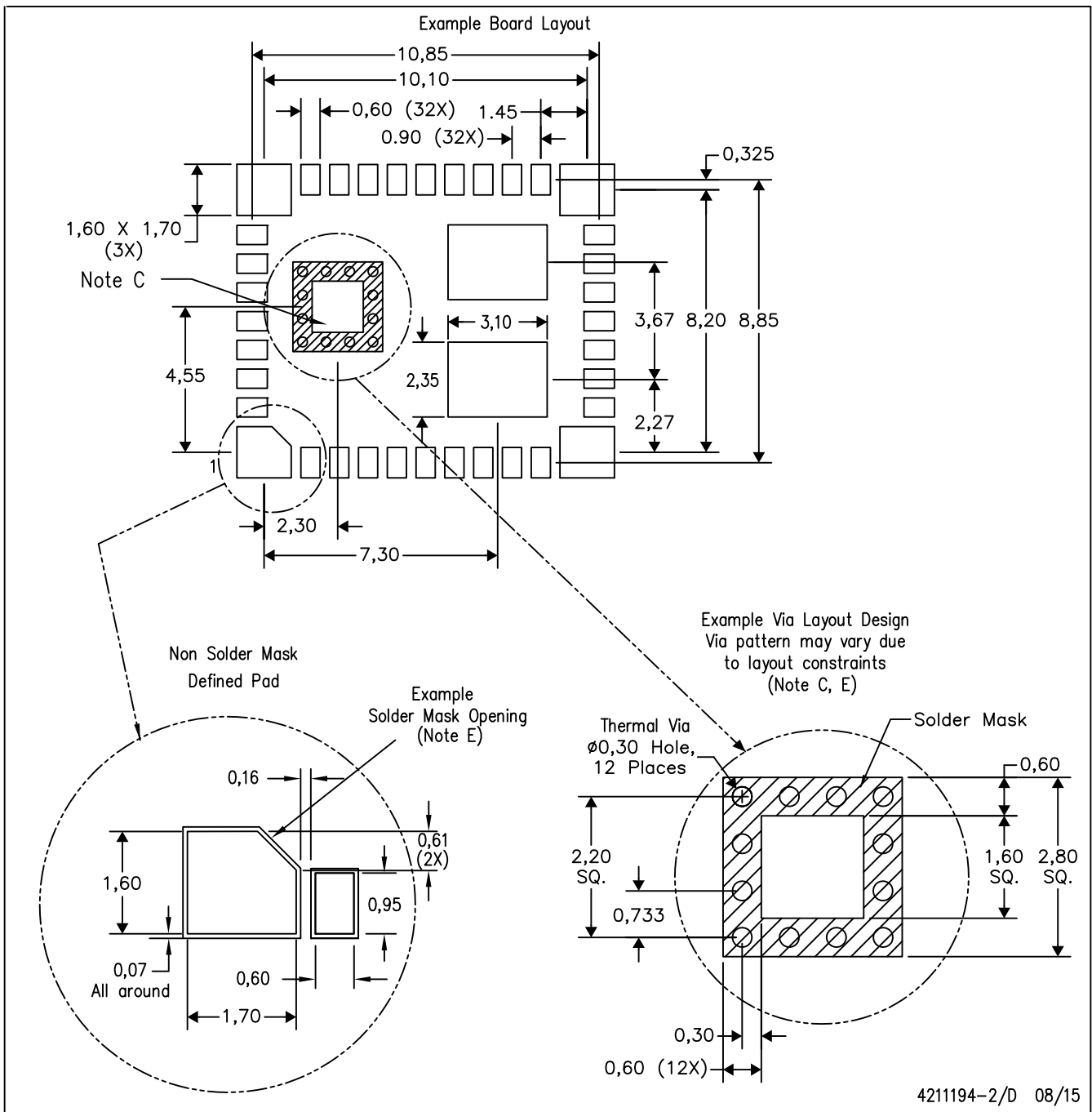

- NOTES:
- A. All linear dimensions are in millimeters.
  - B. This drawing is subject to change without notice.
  - C. This package is designed to be soldered to a thermal pad on the board. Refer to Application Note, Quad Flat-Pack Packages, Texas Instruments Literature No. SLUA271, and also the Product Data Sheets for specific thermal information, via requirements, and recommended board layout. These documents are available at [www.ti.com](http://www.ti.com) <<http://www.ti.com>>.
  - D. Laser cutting apertures with trapezoidal walls and also rounding corners will offer better paste release. Customers should contact their board assembly site for stencil design recommendations. Refer to IPC 7525 for stencil design considerations.
  - E. Customers should contact their board fabrication site for minimum solder mask web tolerances between signal pads.

RKG (S-PB1QFN-N39)

PLASTIC QUAD FLATPACK NO-LEAD

Example Stencil Design (Note D)  
Stencil Thickness = 0,125mm

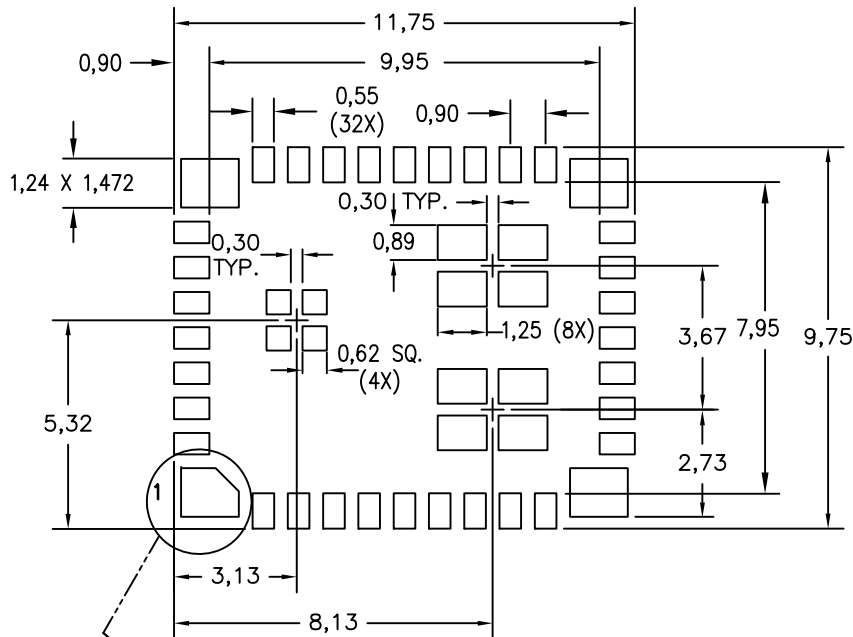

60% solder coverage on thermal pads

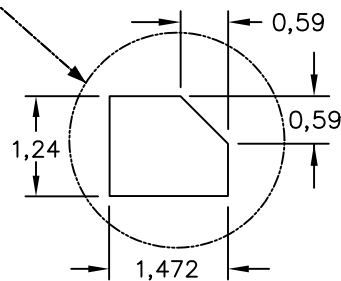

4211194-3/D 08/15

- NOTES:
- A. All linear dimensions are in millimeters.
  - B. This drawing is subject to change without notice.
  - C. This package is designed to be soldered to a thermal pad on the board. Refer to Application Note, Quad Flat-Pack Packages, Texas Instruments Literature No. SLUA271, and also the Product Data Sheets for specific thermal information, via requirements, and recommended board layout. These documents are available at [www.ti.com](http://www.ti.com) <<http://www.ti.com>>.
  - D. Laser cutting apertures with trapezoidal walls and also rounding corners will offer better paste release. Customers should contact their board assembly site for stencil design recommendations. Refer to IPC 7525 for stencil design considerations.
  - E. Customers should contact their board fabrication site for minimum solder mask web tolerances between signal pads.

## 重要声明和免责声明

TI 提供技术和可靠性数据 (包括数据表)、设计资源 (包括参考设计)、应用或其他设计建议、网络工具、安全信息和其他资源, 不保证没有瑕疵且不做任何明示或暗示的担保, 包括但不限于对适销性、某特定用途方面的适用性或不侵犯任何第三方知识产权的暗示担保。

这些资源可供使用 TI 产品进行设计的熟练开发人员使用。您将自行承担以下全部责任: (1) 针对您的应用选择合适的 TI 产品, (2) 设计、验证并测试您的应用, (3) 确保您的应用满足相应标准以及任何其他安全、安保或其他要求。这些资源如有变更, 恕不另行通知。TI 授权您仅可将这些资源用于研发本资源所述的 TI 产品的应用。严禁对这些资源进行其他复制或展示。您无权使用任何其他 TI 知识产权或任何第三方知识产权。您应全额赔偿因在这些资源的使用中对 TI 及其代表造成的任何索赔、损害、成本、损失和债务, TI 对此概不负责。

TI 提供的产品受 TI 的销售条款 (<https://www.ti.com.cn/zh-cn/legal/termsofsale.html>) 或 [ti.com.cn](https://www.ti.com.cn) 上其他适用条款/TI 产品随附的其他适用条款的约束。TI 提供这些资源并不会扩展或以其他方式更改 TI 针对 TI 产品发布的适用的担保或担保免责声明。

邮寄地址: 上海市浦东新区世纪大道 1568 号中建大厦 32 楼, 邮政编码: 200122

Copyright © 2021 德州仪器半导体技术 (上海) 有限公司

## X-ON Electronics

Largest Supplier of Electrical and Electronic Components

*Click to view similar products for [Switching Voltage Regulators](#) category:*

*Click to view products by [Texas Instruments](#) manufacturer:*

Other Similar products are found below :

[FAN53610AUC33X](#) [FAN53611AUC123X](#) [EN6310QA](#) [160215](#) [R3](#) [KE177614](#) [FAN53611AUC12X](#) [MAX809TTR](#) [NCV891234MW50R2G](#)  
[AST1S31PUR](#) [NCP81203PMNTXG](#) [NCP81208MNTXG](#) [PCA9412AUKZ](#) [NCP81109GMNTXG](#) [NCP3235MNTXG](#) [NCP81109JMNTXG](#)  
[NCP81241MNTXG](#) [NTE7223](#) [NTE7222](#) [NTE7224](#) [L6986FTR](#) [MPQ4481GU-AEC1-P](#) [MP8756GD-P](#) [MPQ2171GJ-P](#) [MPQ2171GJ-AEC1-P](#)  
[N JW4153U2-A-TE2](#) [MP2171GJ-P](#) [MP28160GC-Z](#) [XDPE132G5CG000XUMA1](#) [LM60440AQRPKRQ1](#) [MP5461GC-P](#) [IW673-20](#)  
[NCV896530MWATXG](#) [MPQ4409GQBE-AEC1-P](#) [S-19903DA-A8T1U7](#) [S-19903CA-A6T8U7](#) [S-19903CA-S8T1U7](#) [S-19902BA-A6T8U7](#)  
[S-19902CA-A6T8U7](#) [S-19902AA-A6T8U7](#) [S-19903AA-A6T8U7](#) [S-19902AA-S8T1U7](#) [S-19902BA-A8T1U7](#) [AU8310](#)  
[LMR23615QDRRRQ1](#) [LMR33630APAQRN XRQ1](#) [LMR33630APCQRN XRQ1](#) [LMR36503R5RPER](#) [LMR36503RFRPER](#)  
[LMR36503RS3QRPERQ1](#)