

采用 QFN 封装且具有 2.95V 至 17V 输入和电流共享的 LMZ31710 10A 电源模块

1 特性

- 完全集成的电源解决方案
 - 小型扁平设计
 - 与 LMZ31707 和 LMZ31704 之间具有引脚兼容性
 - 10mm × 10mm × 4.3mm 封装
- 效率高达 95%
- Eco-Mode™ 和轻负载效率 (LLE)
- 宽输出电压调节范围为 0.6V 至 5.5V，基准精度为 1%
- 支持针对更高电流的并行运行
- 可选分离电源轨可实现低至 2.95V 的输入电压
- 可调节的开关频率范围 (200kHz 至 1.2MHz)
- 与外部时钟同步
- 提供 180° 异相位时钟信号
- 可调慢速启动
- 输出电压排序和跟踪
- 电源正常输出
- 可编程欠压锁定 (UVLO)
- 过流和过热保护
- 预偏置输出启动
- 工作温度范围: -40°C 至 +85°C
- 增强的散热性能: 13.3°C/W
- 符合 EN55022 B 类辐射发射标准 - 集成屏蔽式电感器
- 利用 LMZ31710 并借助 [WEBENCH® 电源设计器](#) 创建定制设计方案

2 应用

- 宽带和通信基础设施
- 自动测试和医疗设备
- 紧凑型 PCI/PCI 快速接口/PXI 快速接口
- DSP 和 FPGA 负载点应用

3 说明

LMZ31710 电源模块是一款易于使用的集成式电源解决方案，它在一个扁平的 QFN 封装内整合了一个带有功率 MOSFET 的 10A 直流/直流转换器、一个屏蔽式电感器和多个无源器件。此整体电源解决方案仅需三个外部组件，并省去了环路补偿和磁性元件选择过程。

此器件采用 10 × 10 × 4.3mm QFN 封装，可轻松焊接到印刷电路板上，并可实现紧凑的负载点设计。此器件可实现超过 95% 的效率，具有热阻为 13.3°C/W 的出色功率耗散能力。LMZ31710 提供离散负载点设计所具有的灵活性和特性集，非常适合为广泛的集成电路 (IC) 和系统供电。先进的封装技术可提供一个与标准 QFN 贴装和测试技术兼容的稳健耐用且可靠的电源解决方案。

器件信息⁽¹⁾

器件型号	封装	封装尺寸 (标称值)
LMZ31710	RVQ (42)	10.00mm x 10.00mm

(1) 如需了解所有可用封装，请参阅数据表末尾的可订购产品附录。

简化应用

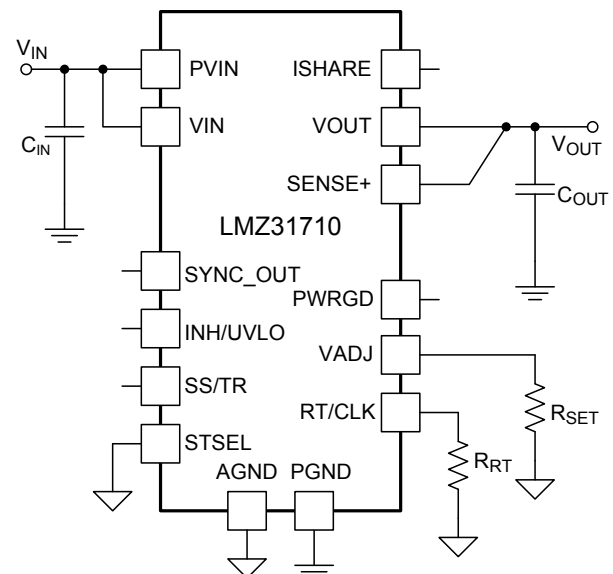

目录

1	特性	1	8	Application and Implementation	25
2	应用	1	8.1	Application Information.....	25
3	说明	1	8.2	Typical Application	25
4	修订历史记录	2	8.3	Additional Application Schematics	26
5	Pin Configuration and Functions	3	9	Power Supply Recommendations	27
6	Specifications.....	5	10	Layout.....	28
6.1	Absolute Maximum Ratings	5	10.1	Layout Considerations	28
6.2	ESD Ratings	5	10.2	Layout Examples.....	28
6.3	Recommended Operating Conditions.....	5	11	器件和文档支持	30
6.4	Thermal Information	6	11.1	器件支持	30
6.5	Electrical Characteristics.....	6	11.2	文档支持	30
6.6	Typical Characteristics (P _{VIN} = V _{IN} = 12 V)	8	11.3	接收文档更新通知	30
6.7	Typical Characteristics (P _{VIN} = V _{IN} = 5 V)	9	11.4	支持资源	30
6.8	Typical Characteristics (P _{VIN} = 3.3 V, V _{IN} = 5 V) ...	10	11.5	商标	30
7	Detailed Description	11	11.6	静电放电警告	30
7.1	Overview	11	11.7	Glossary	31
7.2	Functional Block Diagram	11	12	机械、封装和可订购信息	31
7.3	Feature Description.....	12	12.1	Tape and Reel Information	31
7.4	Device Functional Modes.....	24			

4 修订历史记录

Changes from Revision D (April 2019) to Revision E		Page
•	Added V _{OUT} Range values under different I _{OUT} conditions in Table 7	22
Changes from Revision C (April 2018) to Revision D		Page
•	Corrected TBD values in Synchronization Frequency vs Output Voltage Table	22
Changes from Revision B (June 2017) to Revision C		Page
•	已添加 添加了 LMZ31710 的 WEBENCH® 设计链接	1
•	Increased the peak reflow temperature and maximum number of reflows to JEDEC specifications for improved manufacturability.....	5
Changes from Revision A (July 2013) to Revision B		Page
•	已更改 更改了 器件信息 和 引脚配置和功能 部分、“ESD 额定值”表、特性 说明、器件功能模式、应用和 实施、电源相关建议、布局、器件和文档支持 和 机械、封装和可订购信息 部分	1
•	Added peak reflow and maximum number of reflows information	5

5 Pin Configuration and Functions

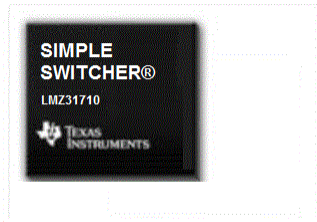

10 mm x 10 mm x 4.3 mm

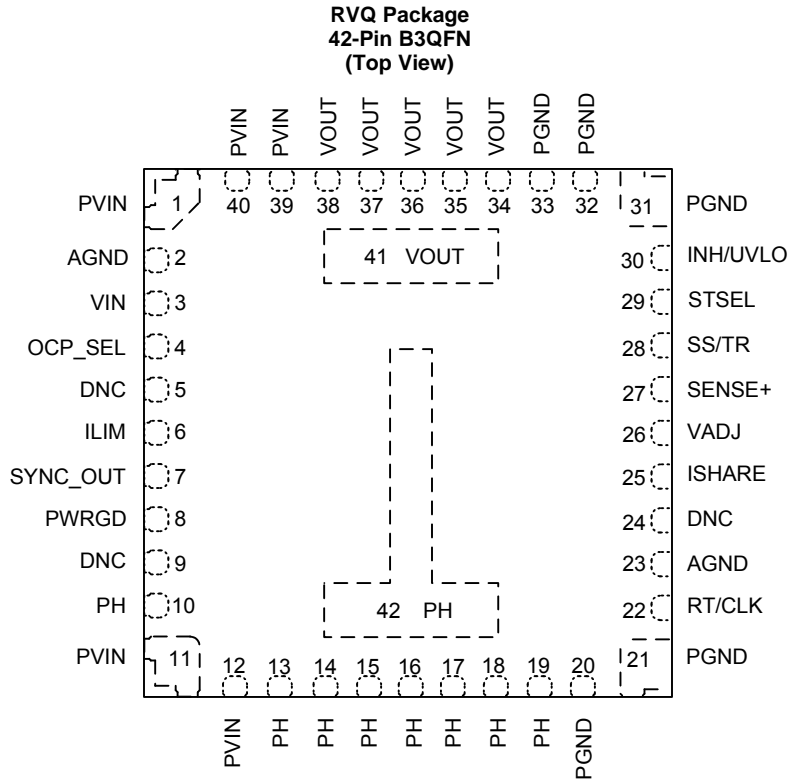

Pin Functions

PIN		TYPE	DESCRIPTION
NAME	NO.		
AGND	2	-	Zero volt reference for the analog control circuit. These pins are not connected together internal to the device and must be connected to one another using an AGND plane of the PCB. These pins are associated with the internal analog ground (AGND) of the device. Keep AGND separate from PGND, as a single connection is made internal to the device. See Layout .
	23		
PGND	20	-	This is the return current path for the power stage of the device. Connect these pins to the load and to the bypass capacitors associated with PVIN and VOUT. Keep PGND separate from AGND, as a single connection is made internal to the device.
	21		
	31		
	32		
	33		
VIN	3	I	Input bias voltage pin. Supplies the control circuitry of the power converter. Connect this pin to the input bias supply. Connect bypass capacitors between this pin and PGND.

Pin Functions (continued)

PIN		TYPE	DESCRIPTION
NAME	NO.		
PVIN	1	I	Input switching voltage. Supplies voltage to the power switches of the converter. Connect these pins to the input supply. Connect bypass capacitors between these pins and PGND.
	11		
	12		
	39		
	40		
VOUT	34	O	Output voltage. These pins are connected to the internal output inductor. Connect these pins to the output load and connect external bypass capacitors between these pins and PGND.
	35		
	36		
	37		
	38		
	41		
PH	10	O	Phase switch node. These pins must be connected to one another using a small copper island under the device for thermal relief. Do not place any external component on these pins or tie them to a pin of another function.
	13		
	14		
	15		
	16		
	17		
	18		
	19		
	42		
DNC	5	-	Do Not Connect. Do not connect these pins to AGND, to another DNC pin, or to any other voltage. These pins are connected to internal circuitry. Each pin must be soldered to an isolated pad.
	9		
	24		
ISHARE	25	O	Current share pin. Connect this pin to other LMZ31710 device's ISHARE pin when paralleling multiple LMZ31710 devices. When unused, treat this pin as a Do Not Connect (DNC) and leave it isolated from all other signals or ground.
OCP_SEL	4	I	Over current protection select pin. Leave this pin open for hiccup mode operation. Connect this pin to AGND for cycle-by-cycle operation. See Overcurrent Protection for more details.
ILIM	6	I	Current limit pin. Leave this pin open for full current limit threshold. Connect this pin to AGND to reduce the current limit threshold by approximately 3 A.
SYNC_OUT	7	O	Synchronization output pin. Provides a 180° out-of-phase clock signal.
PWRGD	8	O	Power Good flag pin. This open drain output asserts low if the output voltage is more than approximately ±6% out of regulation. A pull-up resistor is required.
RT/CLK	22	I	This pin is connected to an internal frequency setting resistor which sets the default switching frequency. An external resistor can be connected from this pin to AGND to increase the frequency. This pin can also be used to synchronize to an external clock.
VADJ	26	I	Connecting a resistor between this pin and AGND sets the output voltage.
SENSE+	27	O	Remote sense connection. This pin must be connected to VOUT at the load or at the device pins. Connect this pin to VOUT at the load for improved regulation.
SS/TR	28	I	Slow-start and tracking pin. Connecting an external capacitor to this pin adjusts the output voltage rise time. A voltage applied to this pin allows for tracking and sequencing control.
STSEL	29	I	Slow-start or track feature select. Connect this pin to AGND to enable the internal SS capacitor. Leave this pin open to enable the TR feature.
INH/UVLO	30	I	Inhibit and UVLO adjust pin. Use an open drain or open collector logic device to ground this pin to control the INH function. A resistor divider between this pin, AGND, and PVIN/VIN sets the UVLO voltage.

6 Specifications

6.1 Absolute Maximum Ratings

over operating free-air temperature range (unless otherwise noted)⁽¹⁾

		MIN	MAX	UNIT
Input voltage	VIN, PVIN	-0.3	20	V
	INH/UVLO, PWRGD, RT/CLK, SENSE+	-0.3	6	V
	ILIM, VADJ, SS/TR, STSEL, SYNC_OUT, ISHARE, OCP_SEL	-0.3	3	V
Output voltage	PH	-1.0	20	V
	PH 10ns Transient	-3.0	20	V
	VOUT	-0.3	10	V
Source current	RT/CLK, INH/UVLO		±100	µA
	PH		current limit	A
Sink current	PH		current limit	A
	PVIN		current limit	A
	PWRGD	-0.1	2	mA
Operating junction temperature		-40	125 ⁽²⁾	°C
Storage temperature, T _{stg}		-65	150	°C
Peak Reflow Case Temperature ⁽³⁾			245 ⁽⁴⁾	°C
Maximum Number of Reflows Allowed ⁽³⁾			3 ⁽⁴⁾	
Mechanical shock	Mil-STD-883D, Method 2002.3, 1 msec, 1/2 sine, mounted		1500	G
Mechanical vibration	Mil-STD-883D, Method 2007.2, 20-2000 Hz		20	

- (1) Stresses beyond those listed under *Absolute Maximum Ratings* may cause permanent damage to the device. These are stress ratings only, which do not imply functional operation of the device at these or any other conditions beyond those indicated under *Recommended Operating Conditions*. Exposure to absolute-maximum-rated conditions for extended periods may affect device reliability.
- (2) See the temperature derating curves in the Typical Characteristics section for thermal information.
- (3) For soldering specifications, refer to the [Soldering Requirements for BQFN Packages](#) application note.
- (4) Devices with a date code prior to week 14 2018 (1814) have a peak reflow case temperature of 240°C with a maximum of one reflow.

6.2 ESD Ratings

		VALUE	UNIT
V _(ESD) Electrostatic discharge	Human-body model (HBM), per ANSI/ESDA/JEDEC JS-001 ⁽¹⁾	±1500	V
	Charged-device model (CDM), per JEDEC specification JESD22-C101 ⁽²⁾	±1000	

- (1) JEDEC document JEP155 states that 500-V HBM allows safe manufacturing with a standard ESD control process.
- (2) JEDEC document JEP157 states that 250-V CDM allows safe manufacturing with a standard ESD control process.

6.3 Recommended Operating Conditions

over operating free-air temperature range (unless otherwise noted)

	MIN	NOM	MAX	UNIT
Input switching voltage, PV _{IN}	2.95		17	V
Input bias voltage, V _{IN}	4.5		17	V
Output voltage, V _{OUT}	0.6		5.5	V
Switching frequency, f _{SW}	200		1200	kHz

6.4 Thermal Information

THERMAL METRIC ⁽¹⁾		LMZ31710	UNIT
		RVQ (B3QFN)	
		42 PINS	
R _{θJA}	Junction-to-ambient thermal resistance ⁽²⁾	13.3	°C/W
R _{θJB}	Junction-to-board thermal resistance ⁽³⁾	1.6	°C/W
ψ _{JT}	Junction-to-top characterization parameter ⁽⁴⁾	5.3	°C/W

- (1) For more information about traditional and new thermal metrics, see the *Semiconductor and IC Package Thermal Metrics* application report.
- (2) The junction-to-ambient thermal resistance, R_{θJA}, applies to devices soldered directly to a 100 mm × 100 mm double-sided PCB with 2 oz. copper and natural convection cooling. Additional airflow reduces R_{θJA}.
- (3) The junction-to-top characterization parameter, ψ_{JT}, estimates the junction temperature, T_J, of a device in a real system, using a procedure described in JESD51-2A (sections 6 and 7). T_J = ψ_{JT} × P_{dis} + T_T; where P_{dis} is the power dissipated in the device and T_T is the temperature of the top of the device.
- (4) The junction-to-board characterization parameter, ψ_{JB}, estimates the junction temperature, T_J, of a device in a real system, using a procedure described in JESD51-2A (sections 6 and 7). T_J = ψ_{JB} × P_{dis} + T_B; where P_{dis} is the power dissipated in the device and T_B is the temperature of the board 1 mm from the device.

6.5 Electrical Characteristics

Over –40°C to 85°C free-air temperature, P_{VIN} = V_{IN} = 12 V, V_{OUT} = 1.8 V, I_{OUT} = 10 A, C_{IN} = 0.1 μF + 2 × 22 μF ceramic + 100 μF bulk, C_{OUT} = 4 × 47 μF ceramic (unless otherwise noted)

PARAMETER		TEST CONDITIONS	MIN	TYP	MAX	UNIT		
I _{OUT}	Output current	T _A = 85°C, natural convection	0 ⁽¹⁾		10	A		
V _{IN}	Input bias voltage range	Over output current range	4.5		17	V		
PV _{IN}	Input switching voltage range	Over output current range	2.95 ⁽²⁾		17 ⁽³⁾	V		
UVLO	V _{IN} undervoltage lockout	V _{IN} Increasing		4	4.5	V		
		V _{IN} Decreasing	3.5	3.85				
V _{OUT(adj)}	Output voltage adjust range	Over output current range	0.6		5.5 ⁽⁴⁾	V		
V _{OUT}	Set-point voltage tolerance	T _A = 25°C, I _{OUT} = 0 A			±1% ⁽⁵⁾			
	Temperature variation	–40°C ≤ T _A ≤ +85°C, I _{OUT} = 0 A		±0.2%				
	Line regulation	Over input voltage range		±0.1%				
	Load regulation	Over output current range		±0.2%				
	Total output voltage variation	Includes set-point, line, load, and temperature variation				±1.5% ⁽⁵⁾		
η	Efficiency	P _{VIN} = V _{IN} = 12 V I _O = 5 A	V _{OUT} = 5 V, f _{SW} = 1 MHz		93%			
			V _{OUT} = 3.3 V, f _{SW} = 750 kHz		92%			
			V _{OUT} = 2.5 V, f _{SW} = 750 kHz		90%			
			V _{OUT} = 1.8 V, f _{SW} = 500 kHz		89%			
			V _{OUT} = 1.2 V, f _{SW} = 300 kHz		86%			
			V _{OUT} = 0.9 V, f _{SW} = 250 kHz		84%			
		P _{VIN} = V _{IN} = 5 V I _O = 5 A		V _{OUT} = 3.3 V, f _{SW} = 750 kHz		94%		
				V _{OUT} = 2.5 V, f _{SW} = 750 kHz		93%		
				V _{OUT} = 1.8 V, f _{SW} = 500 kHz		92%		
				V _{OUT} = 1.2 V, f _{SW} = 300 kHz		89%		
				V _{OUT} = 0.9 V, f _{SW} = 250 kHz		87%		
				V _{OUT} = 0.6 V, f _{SW} = 200 kHz		83%		
		Output voltage ripple		20 MHz bandwidth		14		mV _{p-p}
		I _{LIM}	Current limit threshold	ILIM pin open		15		A
ILIM pin to AGND				12		A		

- (1) See *Light Load Efficiency (LLE)* for more information for output voltages < 1.5 V.
- (2) The minimum P_{VIN} is 2.95 V or (V_{OUT} + 0.7 V), whichever is greater. See *Table 7* for more details.
- (3) The maximum PV_{IN} voltage is 17 V or (22 × V_{OUT}), whichever is less. See *Table 7* for more details.
- (4) The maximum output voltage may be limited by the power dissipation. The maximum power dissipation of this device is 4.5 W.
- (5) The stated limit of the set-point voltage tolerance includes the tolerance of both the internal voltage reference and the internal adjustment resistor. The overall output voltage tolerance will be affected by the tolerance of the external R_{SET} resistor.

Electrical Characteristics (continued)

Over -40°C to 85°C free-air temperature, $PV_{\text{IN}} = V_{\text{IN}} = 12\text{ V}$, $V_{\text{OUT}} = 1.8\text{ V}$, $I_{\text{OUT}} = 10\text{ A}$,
 $C_{\text{IN}} = 0.1\text{ }\mu\text{F} + 2 \times 22\text{ }\mu\text{F}$ ceramic + $100\text{ }\mu\text{F}$ bulk, $C_{\text{OUT}} = 4 \times 47\text{ }\mu\text{F}$ ceramic (unless otherwise noted)

PARAMETER		TEST CONDITIONS		MIN	TYP	MAX	UNIT
Transient response		1 A/ μs load step from 25 to 75% $I_{\text{OUT(max)}}$		Recovery time	100		μs
				VOUT over/undershoot	80		mV
V_{INH}	Inhibit threshold voltage	Inhibit High Voltage		1.3		open ⁽⁶⁾	V
		Inhibit Low Voltage		-0.3		1.1	
I_{INH}	INH Input current	$V_{\text{INH}} < 1.1\text{ V}$			-1.15		μA
	INH Hysteresis current	$V_{\text{INH}} > 1.3\text{ V}$			-3.3		μA
$I_{\text{I(stby)}}$	Input standby current	INH pin to AGND			2	10	μA
Power Good	PWRGD Thresholds	V_{OUT} rising	Good		95%		
			Fault		108%		
		V_{OUT} falling	Fault		91%		
			Good		104%		
PWRGD Low Voltage		$I(\text{PWRGD}) = 0.5\text{ mA}$				0.3	V
f_{SW}	Switching frequency	$R_{\text{RT}} = 169\text{ k}\Omega$		400	500	600	kHz
f_{CLK}	Synchronization frequency	CLK Control		200		1200	kHz
$V_{\text{CLK-H}}$	CLK High-Level			2		5.5	V
$V_{\text{CLK-L}}$	CLK Low-Level					0.5	V
D_{CLK}	CLK Duty Cycle			20%	50%	80%	
Thermal Shutdown				Thermal shutdown			175
		Thermal shutdown hysteresis			10		$^{\circ}\text{C}$
C_{IN}	External input capacitance	Ceramic		44 ⁽⁷⁾			μF
		Non-ceramic			100 ⁽⁷⁾		
C_{OUT}	External output capacitance	$V_{\text{OUT}} = 0.6\text{ V to }5.5\text{ V}$	Ceramic	47 ⁽⁸⁾	200	1500	μF
		$V_{\text{OUT}} = 0.6\text{ V to }5.5\text{ V}$	Non-ceramic		220 ⁽⁸⁾	5000 ⁽⁹⁾	
		Equivalent series resistance (ESR)					

- (6) Value when no voltage divider is present at the INH/UVLO pin. This pin has an internal pullup. If it is left open, the device operates when input power is applied. A small, low-leakage MOSFET is recommended for control. Do not tie this pin to VIN.
- (7) A minimum of 44 μF of external ceramic capacitance is required across the input (VIN and PVIN connected) for proper operation. An additional 100 μF of bulk capacitance is recommended. It is also recommended to place a 0.1 μF ceramic capacitor directly across the PVIN and PGND pins of the device. Locate the input capacitance close to the device. When operating with split VIN and PVIN rails, place 4.7 μF of ceramic capacitance directly at the VIN pin. See [Table 4](#) for more details.
- (8) The amount of required output capacitance varies depending on the output voltage (see [Table 3](#)). The amount of required capacitance must include at least $1 \times 47\text{ }\mu\text{F}$ ceramic capacitor. Locate the capacitance close to the device. Adding additional capacitance close to the load improves the response of the regulator to load transients. See [Table 3](#) and [Table 4](#) more details.
- (9) The maximum output capacitance of 5000 μF includes the combination of both ceramic and non-ceramic capacitors. It may be necessary to increase the slow-start time when turning on into the maximum capacitance. See the [Slow Start \(SS/TR\)](#) section for information on adjusting the slow-start time.

6.6 Typical Characteristics ($P_{VIN} = V_{IN} = 12\text{ V}$)

The electrical characteristic data has been developed from actual products tested at 25°C. This data is considered typical for the converter. Applies to Figure 1, Figure 2, and Figure 3. The temperature derating curves represent the conditions at which internal components are at or below the manufacturer's maximum operating temperatures. Derating limits apply to devices soldered directly to a 100 mm × 100 mm double-sided PCB with 2 oz. copper. Applies to Figure 5 and Figure 6.

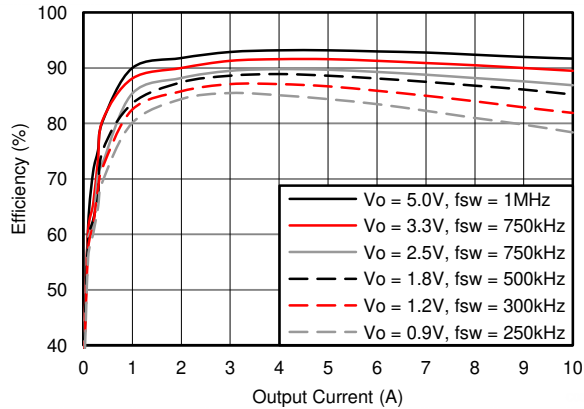

Figure 1. Efficiency versus Output Current

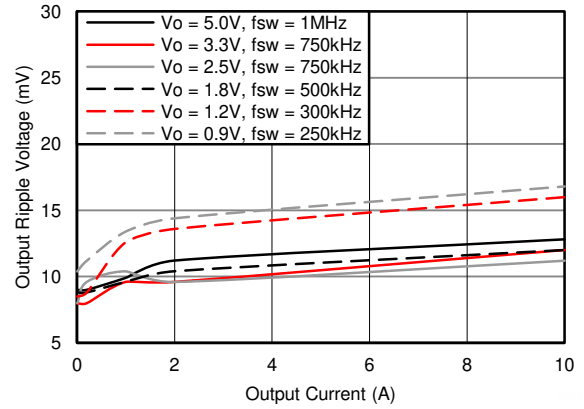

Figure 2. Voltage Ripple versus Output Current

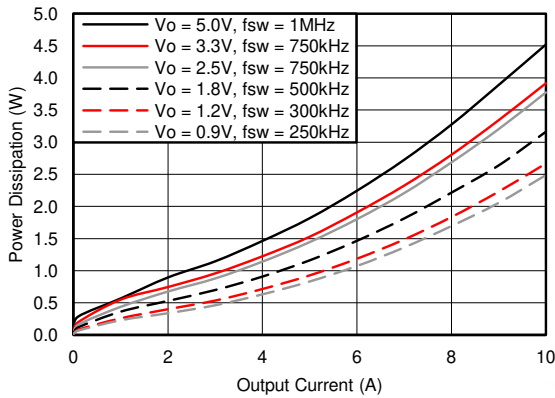

Figure 3. Power Dissipation versus Output Current

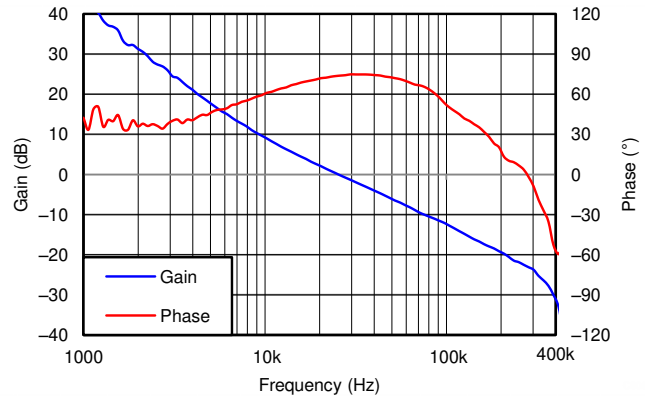

Figure 4. $V_{OUT} = 1.8\text{ V}$, $I_{OUT} = 10\text{ A}$, $C_{OUT1} = 200\text{ Mf Ceramic}$, $F_{SW} = 500\text{ KHz}$

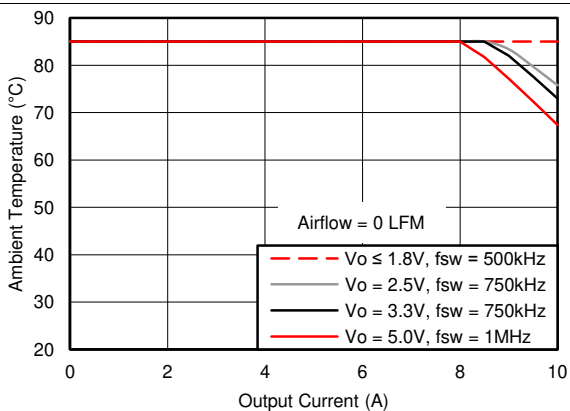

Figure 5. Safe Operating Area

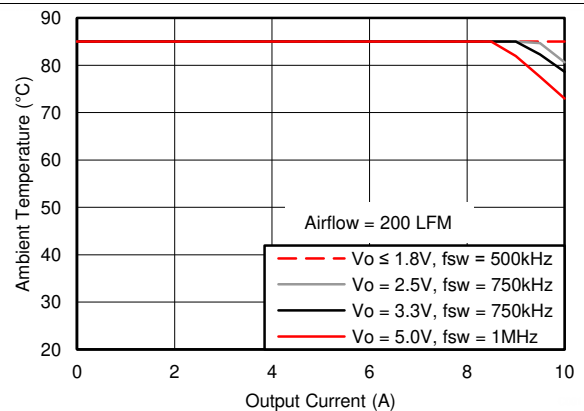

Figure 6. Safe Operating Area

6.7 Typical Characteristics ($P_{VIN} = V_{IN} = 5\text{ V}$)

The electrical characteristic data has been developed from actual products tested at 25°C. This data is considered typical for the converter. Applies to Figure 7, Figure 8, and Figure 9. The temperature derating curves represent the conditions at which internal components are at or below the manufacturer's maximum operating temperatures. Derating limits apply to devices soldered directly to a 100 mm × 100 mm double-sided PCB with 2 oz. copper. Applies to Figure 11.

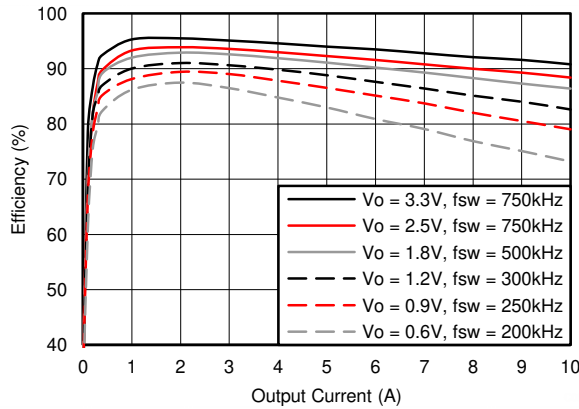

Figure 7. Efficiency versus Output Current

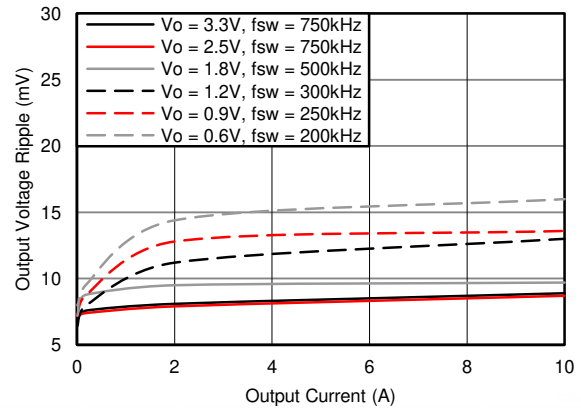

Figure 8. Voltage Ripple versus Output Current

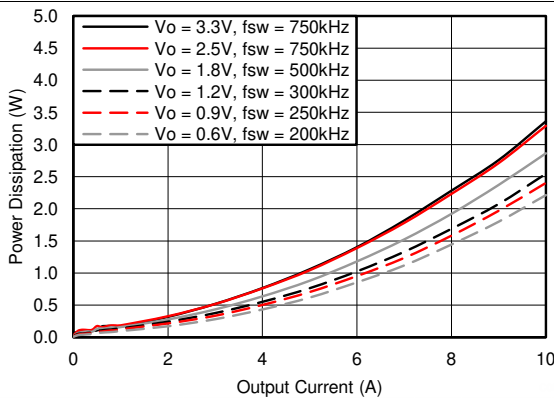

Figure 9. Power Dissipation versus Output Current

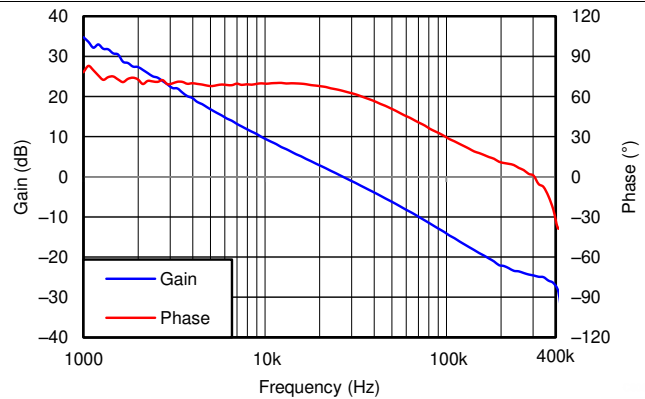

Figure 10. $V_{OUT} = 1.8\text{ V}$, $I_{OUT} = 10\text{ A}$, $C_{OUT1} = 200\text{ Mf Ceramic}$, $F_{SW} = 500\text{ KHz}$

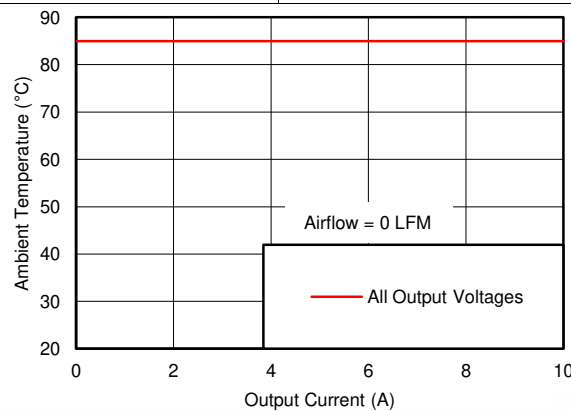

Figure 11. Safe Operating Area

6.8 Typical Characteristics ($P_{VIN} = 3.3\text{ V}$, $V_{IN} = 5\text{ V}$)

The electrical characteristic data has been developed from actual products tested at 25°C. This data is considered typical for the converter. Applies to Figure 12, Figure 13, and Figure 14. The temperature derating curves represent the conditions at which internal components are at or below the manufacturer's maximum operating temperatures. Derating limits apply to devices soldered directly to a 100-mm x 100-mm double-sided PCB with 2 oz. copper. Applies to Figure 16.

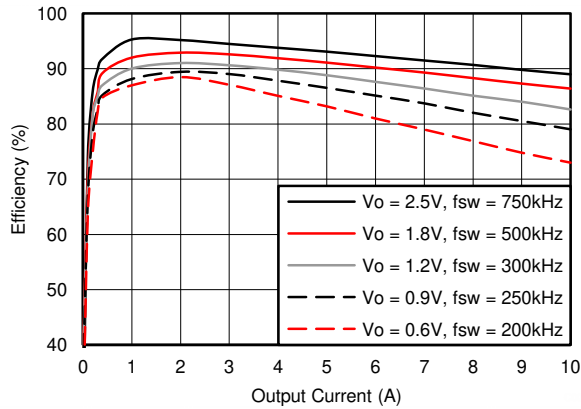

Figure 12. Efficiency versus Output Current

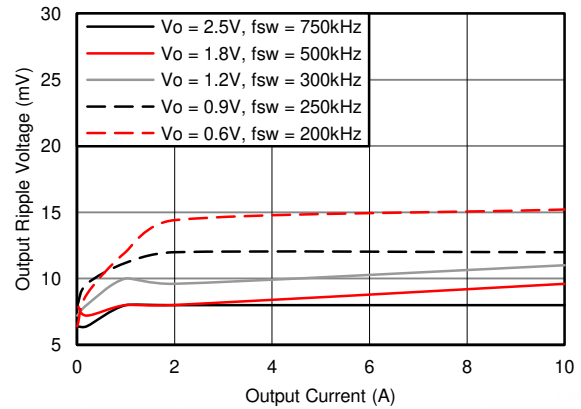

Figure 13. Voltage Ripple versus Output Current

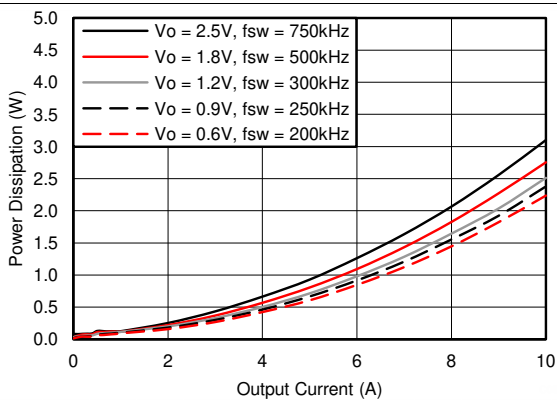

Figure 14. Power Dissipation versus Output Current

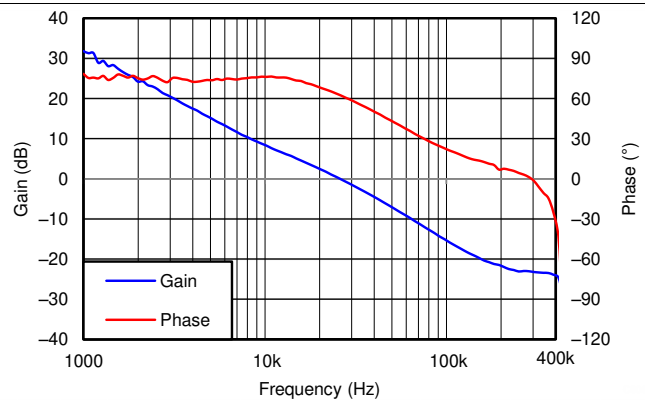

Figure 15. $V_{OUT} = 1.8\text{ V}$, $I_{OUT} = 10\text{ A}$, $C_{OUT1} = 200\text{ Mf Ceramic}$, $F_{SW} = 500\text{ KHz}$

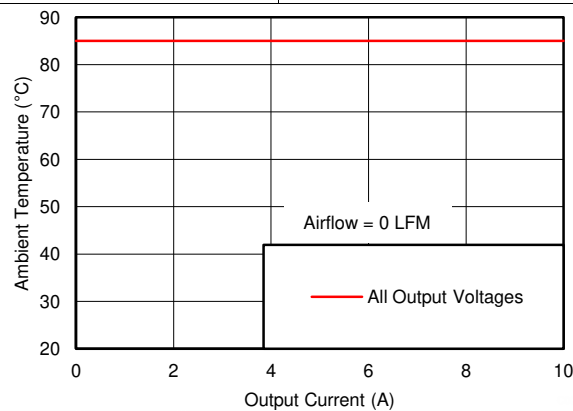

Figure 16. Safe Operating Area

7 Detailed Description

7.1 Overview

The LMZ31710 is a full-featured 2.95 V to 17 V input, 10-A, synchronous step-down converter with PWM, MOSFETs, inductor, and control circuitry integrated into a low-profile, overmolded package. This device enables small designs by integrating all but the input and output capacitors, while still leaving the ability to adjust key parameters to meet specific design requirements. The LMZ31710 provides a wide output voltage range of 0.6 V to 5.5 V. In most applications, a single external resistor is used to adjust the output voltage. The switching frequency is also adjustable by using an external resistor or a synchronization pulse to accommodate various input/output voltage conditions and to optimize efficiency. The device provides accurate voltage regulation for a variety of loads by using an internal voltage reference that is $\pm 1\%$ accurate over temperature. The INH/UVLO pin can be pulled low to put the device in standby mode to reduce input quiescent current. The input under-voltage lockout can be adjusted using a resistor divider on the IN/UVLO pin of the device. The device provides a power good signal to indicate when the output is within $\pm 5\%$ of its nominal voltage. The ability to parallel the LMZ31710 allows it to be used in higher current applications. Thermal shutdown and current limit features protect the device during an overload condition. Automatic pulse skip mode improves light-load efficiency. A 42-pin, QFN, package that includes exposed bottom pads provides a thermally enhanced solution for space-constrained applications.

7.2 Functional Block Diagram

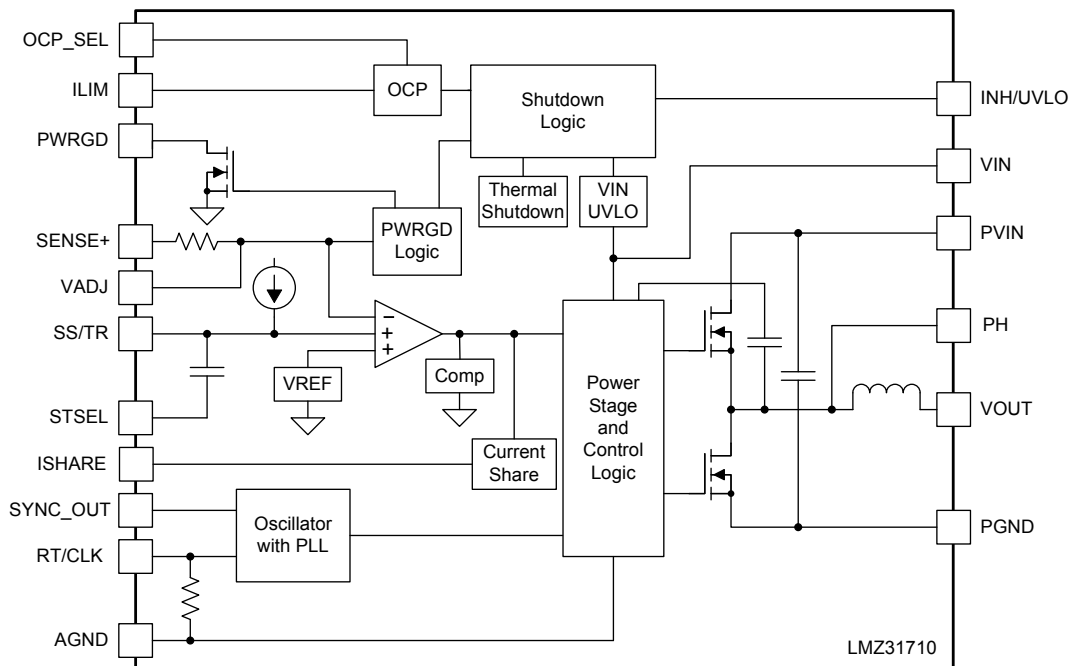

7.3 Feature Description

7.3.1 VIN and PVIN Input Voltage

The LMZ31710 allows for a variety of applications by using the VIN and PVIN pins together or separately. The VIN voltage supplies the internal control circuits of the device. The PVIN voltage provides the input voltage to the power converter system.

If tied together, the input voltage for the VIN pin and the PVIN pin can range from 4.5 V to 17 V. If using the VIN pin separately from the PVIN pin, the VIN pin must be greater than 4.5 V, and the PVIN pin can range from as low as 2.95 V to 17 V. When operating from a split rail, it is recommended to supply VIN from 5 V to 12 V, for best performance. A voltage divider connected to the INH/UVLO pin can adjust either input voltage UVLO appropriately. See [Programmable Undervoltage Lockout \(UVLO\)](#) for more information.

7.3.2 3.3-V PVIN Operation

Applications operating from a PVIN of 3.3 V must provide at least 4.5 V for VIN. It is recommended to supply V_{IN} from 5 V to 12 V, for best performance. See the [Powering LMZ3 SIMPLE SWITCHER Power Modules From 3.3 V Application Note](#) for help creating 5 V from 3.3 V using a small, simple charge pump device.

7.3.3 Adjusting the Output Voltage (0.6 V to 5.5 V)

The VADJ control sets the output voltage of the LMZ31710. The output voltage adjustment range of the LMZ31710 is from 0.6 V to 5.5 V. The adjustment method requires the addition of R_{SET} , which sets the output voltage, the connection of SENSE+ to VOUT, and in some cases R_{RT} which sets the switching frequency. The R_{SET} resistor must be connected directly between the VADJ (pin 26) and AGND (pin 23). The SENSE+ pin (pin 27) must be connected to VOUT either at the load for improved regulation or at VOUT of the device. The R_{RT} resistor must be connected directly between the RT/CLK (pin 22) and AGND (pin 23). [Table 1](#) gives the standard external R_{SET} resistor for a number of common bus voltages, along with the recommended R_{RT} resistor for that output voltage.

Table 1. Standard R_{SET} Resistor Values for Common Output Voltages

RESISTORS	OUTPUT VOLTAGE V_{OUT} (V)						
	0.9	1.0	1.2	1.8	2.5	3.3	5.0
R_{SET} (k Ω)	2.87	2.15	1.43	0.715	0.453	0.316	0.196
R_{RT} (k Ω)	1000	1000	487	169	90.9	90.9	63.4

For other output voltages, the value of the required resistor can either be calculated using the following formula, or simply selected from the range of values given in [Table 2](#).

$$R_{SET} = \frac{1.43}{\left(\left(\frac{V_{OUT}}{0.6}\right) - 1\right)} \text{ (k}\Omega\text{)} \quad (1)$$

Table 2. Standard R_{SET} Resistor Values

V _{OUT} (V)	R _{SET} (kΩ)	R _{RT} (kΩ)	f _{sw} (kHz)	V _{OUT} (V)	R _{SET} (kΩ)	R _{RT} (kΩ)	f _{sw} (kHz)
0.6	open	OPEN	200	3.1	0.348	90.9	750
0.7	8.66	OPEN	200	3.2	0.332	90.9	750
0.8	4.32	OPEN	200	3.3	0.316	90.9	750
0.9	2.87	1000	250	3.4	0.309	90.9	750
1.0	2.15	1000	250	3.5	0.294	90.9	750
1.1	1.74	1000	250	3.6	0.287	90.9	750
1.2	1.43	487	300	3.7	0.280	90.9	750
1.3	1.24	487	300	3.8	0.267	90.9	750
1.4	1.07	487	300	3.9	0.261	90.9	750
1.5	0.953	487	300	4.0	0.255	90.9	750
1.6	0.866	487	300	4.1	0.243	63.4	1000
1.7	0.787	487	300	4.2	0.237	63.4	1000
1.8	0.715	169	500	4.3	0.232	63.4	1000
1.9	0.665	169	500	4.4	0.226	63.4	1000
2.0	0.619	169	500	4.5	0.221	63.4	1000
2.1	0.576	169	500	4.6	0.215	63.4	1000
2.2	0.536	169	500	4.7	0.210	63.4	1000
2.3	0.511	169	500	4.8	0.205	63.4	1000
2.4	0.475	169	500	4.9	0.200	63.4	1000
2.5	0.453	90.9	750	5.0	0.196	63.4	1000
2.6	0.432	90.9	750	5.1	0.191	63.4	1000
2.7	0.412	90.9	750	5.2	0.187	63.4	1000
2.8	0.392	90.9	750	5.3	0.182	63.4	1000
2.9	0.374	90.9	750	5.4	0.178	63.4	1000
3.0	0.357	90.9	750	5.5	0.174	63.4	1000

7.3.4 Capacitor Recommendations For the LMZ31710 Power Supply

7.3.4.1 Capacitor Technologies

7.3.4.1.1 Electrolytic, Polymer-Electrolytic Capacitors

When using electrolytic capacitors, high-quality, computer-grade electrolytic capacitors are recommended. Polymer-electrolytic type capacitors are recommended for applications where the ambient operating temperature is less than 0°C. The Sanyo OS-CON capacitor series is suggested due to the lower ESR, higher rated surge, power dissipation, ripple current capability, and small package size. Aluminum electrolytic capacitors provide adequate decoupling over the frequency range of 2 kHz to 150 kHz, and are suitable when ambient temperatures are above 0°C.

7.3.4.1.2 Ceramic Capacitors

The performance of aluminum electrolytic capacitors is less effective than ceramic capacitors above 150 kHz. Multilayer ceramic capacitors have a low ESR and a resonant frequency higher than the bandwidth of the regulator. They can be used to reduce the reflected ripple current at the input as well as improve the transient response of the output.

7.3.4.1.3 Tantalum, Polymer-Tantalum Capacitors

Polymer-tantalum type capacitors are recommended for applications where the ambient operating temperature is less than 0°C. The Sanyo POSCAP series and Kemet T530 capacitor series are recommended rather than many other tantalum types due to their lower ESR, higher rated surge, power dissipation, ripple current capability, and small package size. Tantalum capacitors that have no stated ESR or surge current rating are not recommended for power applications.

7.3.4.2 Input Capacitor

The LMZ31710 requires a minimum input capacitance of 44 μF of ceramic type. An additional 100 μF of non-ceramic capacitance is recommended for applications with transient load requirements. The voltage rating of input capacitors must be greater than the maximum input voltage. At worst case, when operating at 50% duty cycle and maximum load, the combined ripple current rating of the input capacitors must be at least 5 Arms. Table 4 includes a preferred list of capacitors by vendor. It is also recommended to place a 0.1- μF ceramic capacitor directly across the PVIN and PGND pins of the device. When operating with split VIN and PVIN rails, place 4.7 μF of ceramic capacitance directly at the VIN pin.

7.3.4.3 Output Capacitor

The required output capacitance is determined by the output voltage of the LMZ31710. See Table 3 for the amount of required capacitance. The effects of temperature and capacitor voltage rating must be considered when selecting capacitors to meet the minimum required capacitance. The required output capacitance can be comprised of all ceramic capacitors, or a combination of ceramic and bulk capacitors. The required capacitance must include at least one 47 μF ceramic. When adding additional non-ceramic bulk capacitors, low-ESR devices like the ones recommended in Table 4 are required. The required capacitance above the minimum is determined by actual transient deviation requirements. See Table 5 for typical transient response values for several output voltage, input voltage and capacitance combinations. Table 4 includes a preferred list of capacitors by vendor.

Table 3. Required Output Capacitance

$V_{\text{OUT RANGE (V)}}$		MINIMUM REQUIRED $C_{\text{OUT}} (\mu\text{F})$
MIN	MAX	
0.6	< 0.8	500 $\mu\text{F}^{(1)}$
0.8	< 1.2	300 $\mu\text{F}^{(1)}$
1.2	< 3.0	200 $\mu\text{F}^{(1)}$
3.0	< 4.0	100 $\mu\text{F}^{(1)}$
4.0	5.5	47 μF ceramic

(1) Minimum required must include at least one 47 μF ceramic capacitor.

Table 4. Recommended Input/Output Capacitors⁽¹⁾

VENDOR	SERIES	PART NUMBER	CAPACITOR CHARACTERISTICS		
			WORKING VOLTAGE (V)	CAPACITANCE (μF)	ESR ⁽²⁾ (m Ω)
Murata	X5R	GRM32ER61E226K	25	22	2
TDK	X5R	C3225X5R0J107M	6.3	100	2
TDK	X5R	C3225X5R0J476K	6.3	47	2
Murata	X5R	GRM32ER60J107M	6.3	100	2
Murata	X5R	GRM32ER60J476M	6.3	47	2
Panasonic	EEH-ZA	EEH-ZA1E101XP	25	100	30
Sanyo	POSCAP	16TQC68M	16	68	50
Kemet	T520	T520V107M010ASE025	10	100	25
Sanyo	POSCAP	10TPE220ML	10	220	25
Sanyo	POSCAP	6TPE100MI	6.3	100	25
Sanyo	POSCAP	2R5TPE220M7	2.5	220	7
Kemet	T530	T530D227M006ATE006	6.3	220	6
Kemet	T530	T530D337M006ATE010	6.3	330	10
Sanyo	POSCAP	2TPF330M6	2.0	330	6
Sanyo	POSCAP	6TPE330MFL	6.3	330	15

(1) **Capacitor Supplier Verification, RoHS, Lead-free, and Material Details**

Consult capacitor suppliers regarding availability, material composition, RoHS and lead-free status, and manufacturing process requirements for any capacitors identified in this table.

(2) Maximum ESR at 100 kHz, 25°C.

7.3.5 Transient Response

Table 5. Output Voltage Transient Response

C _{IN1} = 3x 47 μF CERAMIC, C _{IN2} = 100 μF POLYMER-TANTALUM						
V _{OUT} (V)	V _{IN} (V)	C _{OUT1} Ceramic	C _{OUT2} BULK	VOLTAGE DEVIATION (mV)		RECOVERY TIME (μs)
				2.5 A LOAD STEP, (1 A/μs)	5 A LOAD STEP, (1 A/μs)	
0.6	5	500 μF	220 μF	25	60	100
	12	500 μF	220 μF	30	65	100
0.9	5	300 μF	220 μF	40	85	100
		300 μF	470 μF	35	70	110
	12	300 μF	220 μF	45	90	100
		300 μF	470 μF	35	75	110
1.2	5	200 μF	220 μF	55	110	110
		200 μF	470 μF	45	90	110
	12	200 μF	220 μF	55	110	110
		200 μF	470 μF	45	90	110
1.8	5	200 μF	220 μF	70	140	130
		200 μF	470 μF	60	120	140
	12	200 μF	220 μF	70	145	140
		200 μF	470 μF	55	120	150
3.3	5	100 μF	220 μF	115	230	200
	12	100 μF	220 μF	120	240	200

7.3.5.1 Transient Response Waveforms

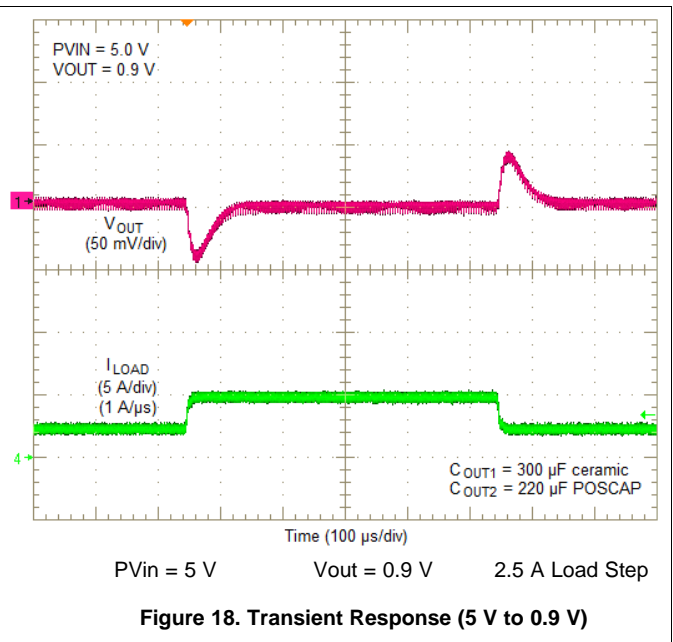
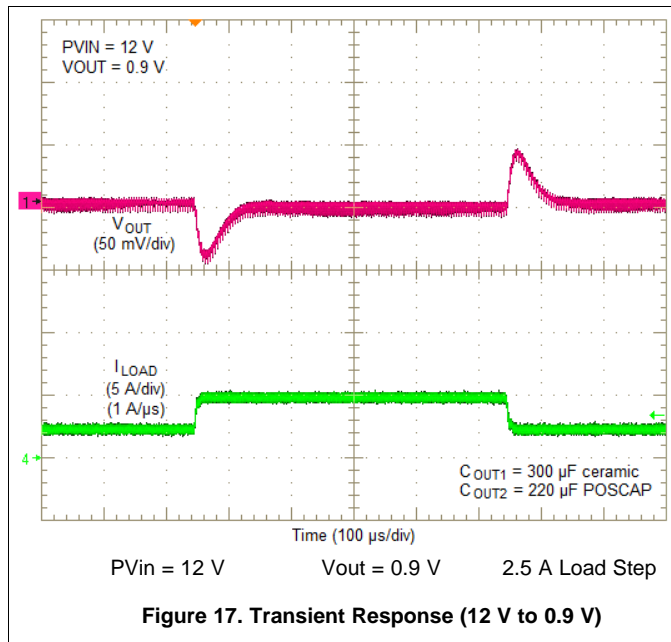

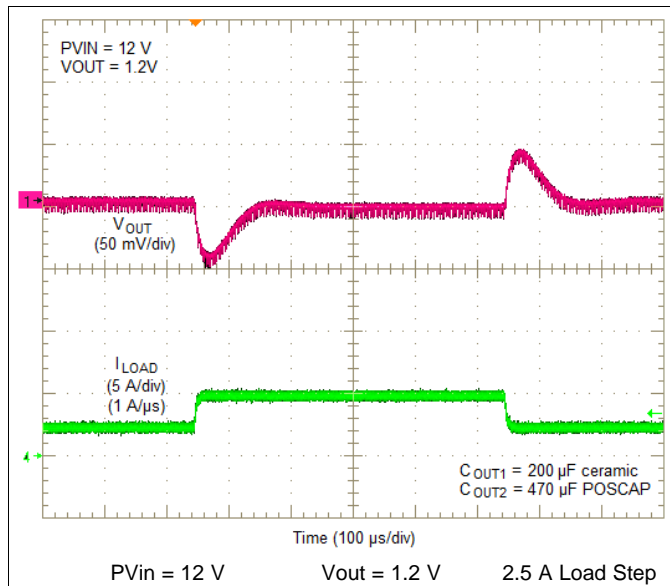
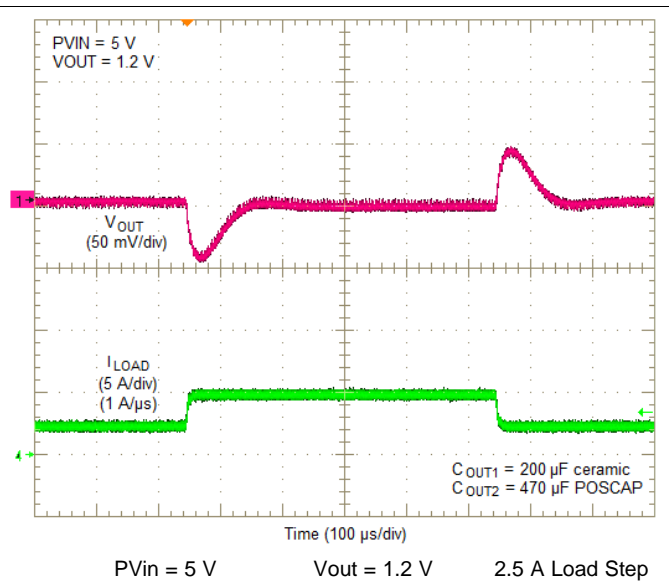
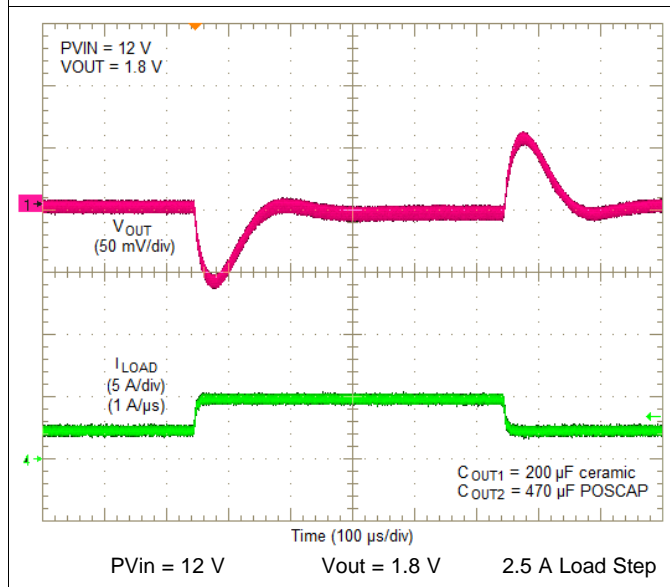
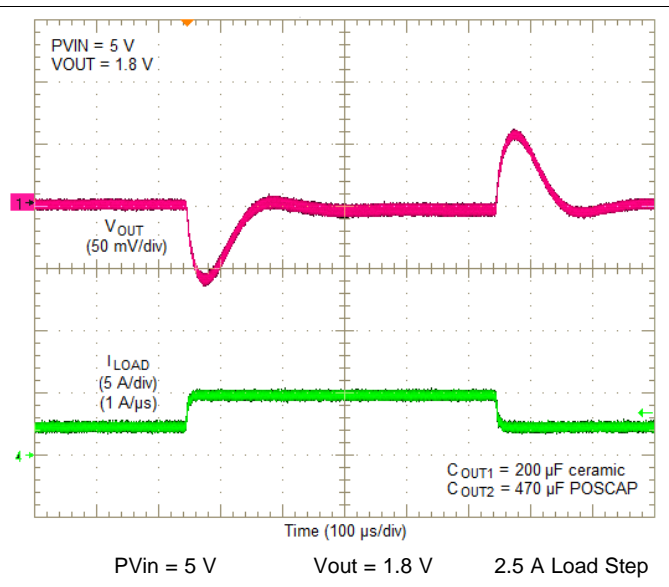
Figure 19. Transient Response (12 V to 1.2 V)

Figure 20. Transient Response (5 V to 1.2 V)

Figure 21. Transient Response (12 V to 1.8 V)

Figure 22. Transient Response (5 V to 1.8 V)

7.3.6 Power Good (PWRGD)

The PWRGD pin is an open drain output. Once the voltage on the SENSE+ pin is between 95% and 104% of the set voltage, the PWRGD pin pulldown is released, and the pin floats. The recommended pullup resistor value is between 10 kΩ and 100 kΩ to a voltage source that is 5.5 V or less. The PWRGD pin is in a defined state once VIN is greater than 1 V, but with reduced current sinking capability. The PWRGD pin achieves full current sinking capability once the VIN pin is above 4.5 V. The PWRGD pin is pulled low when the voltage on SENSE+ is lower than 91% or greater than 108% of the nominal set voltage. Also, the PWRGD pin is pulled low if the input UVLO or thermal shutdown is asserted, the INH pin is pulled low, or the SS/TR pin is below 1.4 V.

7.3.7 Light Load Efficiency (LLE)

The LMZ31710 operates in pulse skip mode at light load currents to improve efficiency and decrease power dissipation by reducing switching and gate drive losses.

These pulses may cause the output voltage to rise when there is no load to discharge the energy. For output voltages < 1.5 V, a minimum load is required. The amount of required load can be determined by Equation 2. In most cases the minimum current drawn by the load circuit will be enough to satisfy this load. Applications requiring a load resistor to meet the minimum load, the added power dissipation will be ≤ 3.6 mW. A single 0402 size resistor across VOUT and PGND can be used.

$$I_{MIN} = 600 \mu A - \left(\frac{V_{OUT}}{1.43k + R_{SET}} \right) (A) \tag{2}$$

When $V_{OUT} = 0.6 V$ and $R_{SET} = OPEN$, the minimum load current is 600 μA .

7.3.8 SYNC_OUT

The LMZ31710 provides a 180° out-of-phase clock signal for applications requiring synchronization. The SYNC_OUT pin produces a 50% duty cycle clock signal that is the same frequency as the device's switching frequency, but is 180° out of phase. Operating two devices 180° out of phase reduces input and output voltage ripple. The SYNC_OUT clock signal is compatible with other LMZ3 devices that have a CLK input.

7.3.9 Parallel Operation

Up to six LMZ31710 devices can be paralleled for increased output current. Multiple connections must be made between the paralleled devices and the component selection is slightly different than for a stand-alone LMZ31710 device. A typical LMZ31710 parallel schematic is shown in Figure 23. Refer to application note, SNVA695 for information and design help when paralleling multiple LMZ31710 devices. Additionally, an EVM featuring two LMZ31710 devices operating in parallel can be evaluated using the LMZ31710X2EVM.

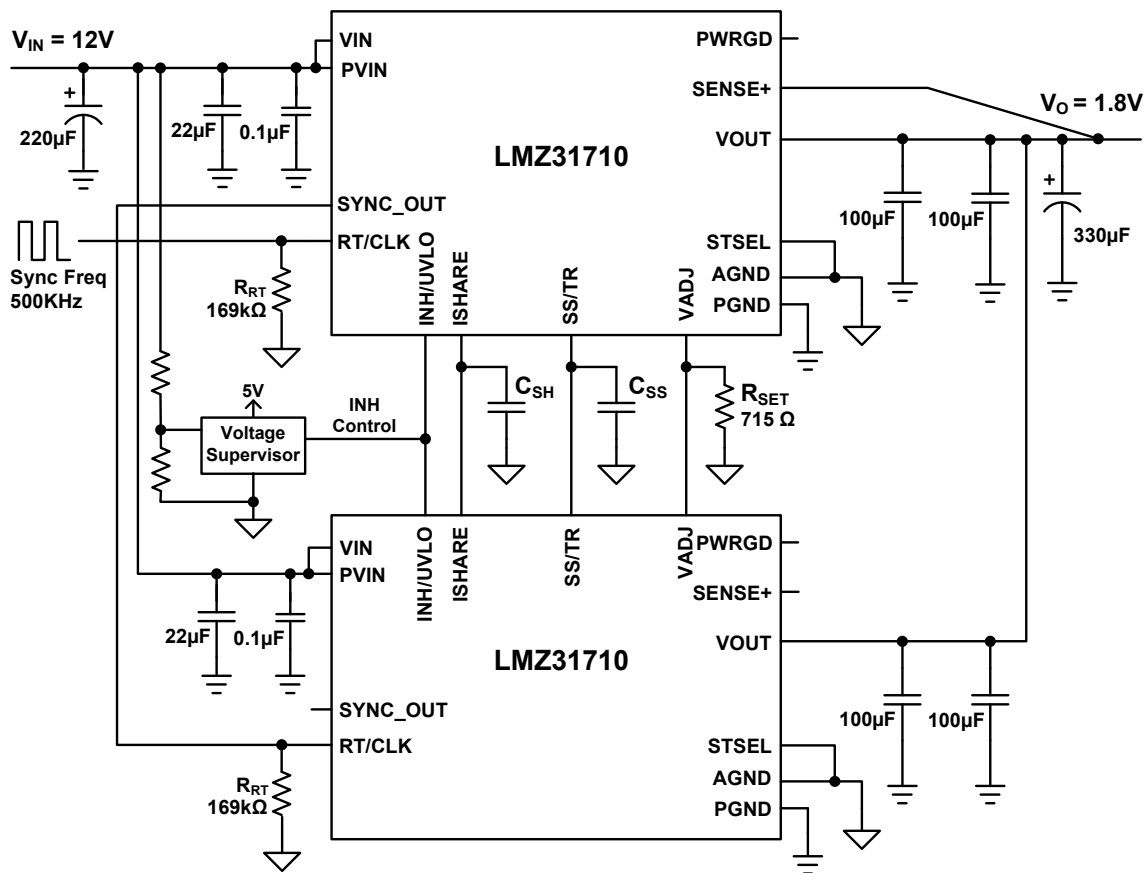
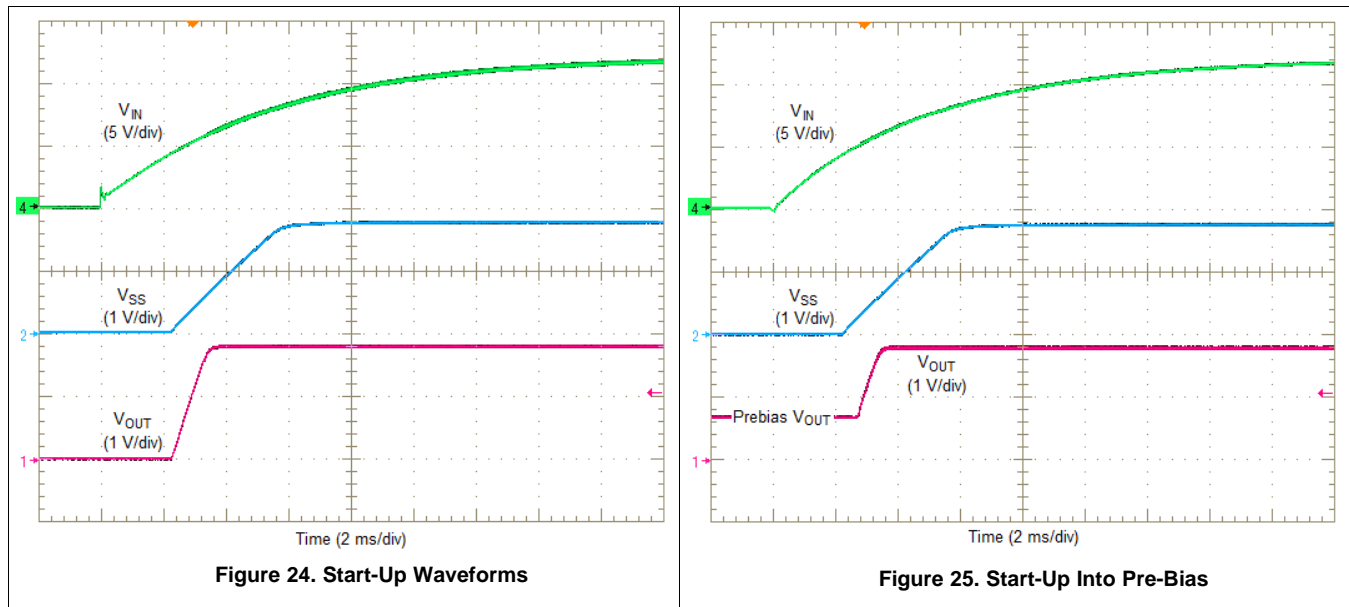

Figure 23. Typical LMZ31710 Parallel Schematic

7.3.10 Power-Up Characteristics

When configured as shown in the application circuit on page 1, the LMZ31710 produces a regulated output voltage following the application of a valid input voltage. During the power-up, internal soft-start circuitry slows the rate that the output voltage rises, thereby limiting the amount of in-rush current that can be drawn from the input source. [Figure 24](#) shows the start-up waveforms for a LMZ31710, operating from a 5-V input ($P_{VIN} = V_{IN}$) and with the output voltage adjusted to 1.8 V. [Figure 25](#) shows the start-up waveforms for a LMZ31710 starting up into a pre-biased output voltage. The waveforms were measured with a 5-A constant current load.



7.3.11 Pre-Biased Start-Up

The LMZ31710 has been designed to prevent the low-side MOSFET from discharging a pre-biased output. During pre-biased startup, the low-side MOSFET does not turn on until the high-side MOSFET has started switching. The high-side MOSFET does not start switching until the slow start voltage exceeds the voltage on the VADJ pin. Refer to [Figure 25](#).

7.3.12 Remote Sense

The SENSE+ pin must be connected to V_{OUT} at the load, or at the device pins.

Connecting the SENSE+ pin to V_{OUT} at the load improves the load regulation performance of the device by allowing it to compensate for any I-R voltage drop between its output pins and the load. An I-R drop is caused by the high output current flowing through the small amount of pin and trace resistance. This must be limited to a maximum of 300 mV.

NOTE

The remote sense feature is not designed to compensate for the forward drop of nonlinear or frequency dependent components that may be placed in series with the converter output. Examples include OR-ing diodes, filter inductors, ferrite beads, and fuses. When these components are enclosed by the SENSE+ connection, they are effectively placed inside the regulation control loop, which can adversely affect the stability of the regulator.

7.3.13 Thermal Shutdown

The internal thermal shutdown circuitry forces the device to stop switching if the junction temperature exceeds 175°C typically. The device reinitiates the power-up sequence when the junction temperature drops below 165°C typically.

7.3.14 Output On/Off Inhibit (INH)

The INH pin provides electrical on/off control of the device. Once the INH pin voltage exceeds the threshold voltage, the device starts operation. If the INH pin voltage is pulled below the threshold voltage, the regulator stops switching and enters low quiescent current state. The INH pin has an internal pull-up current source, allowing the user to float the INH pin for enabling the device.

If an application requires controlling the INH pin, use an open drain/collector device, or a suitable logic gate to interface with the pin. Using a voltage supervisor to control the INH pin allows control of the turn-on and turn-off of the device as opposed to relying on the ramp up or down if the input voltage source.

Figure 26 shows the typical application of the inhibit function. Turning Q1 on applies a low voltage to the inhibit control (INH) pin and disables the output of the supply, shown in Figure 27. If Q1 is turned off, the supply executes a soft-start power-up sequence, as shown in Figure 28. A regulated output voltage is produced within 2 ms. The waveforms were measured with a 5-A constant current load.

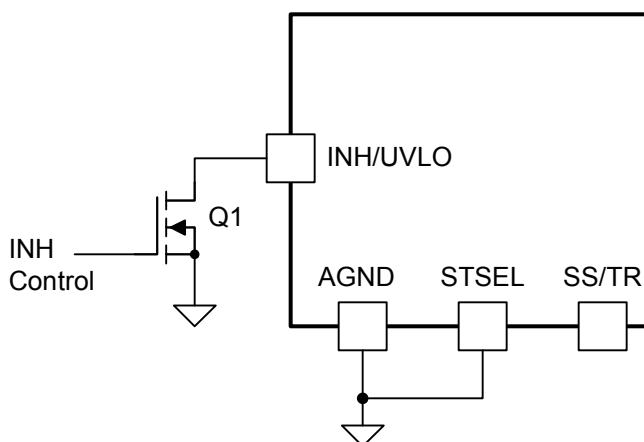
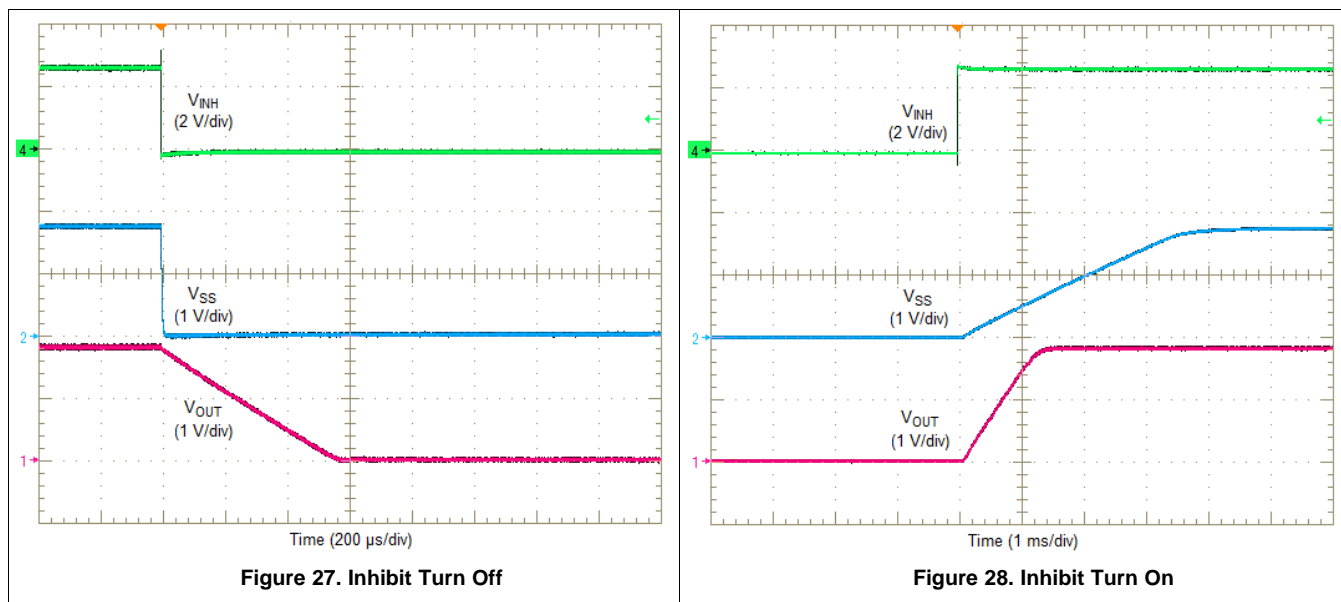

Figure 26. Typical Inhibit Control



7.3.15 Slow Start (SS/TR)

Connecting the STSEL pin to AGND and leaving SS/TR pin open enables the internal SS capacitor with a slow start interval of approximately 1.2 ms. Adding additional capacitance between the SS pin and AGND increases the slow start time. Increasing the slow start time will reduce inrush current seen by the input source and reduce the current seen by the device when charging the output capacitors. To avoid the activation of current limit and ensure proper start-up, the SS capacitor may need to be increased when operating near the maximum output capacitance limit.

Table 6 shows an additional SS capacitor connected to the SS/TR pin and the STSEL pin connected to AGND. See Table 6 for SS capacitor values and timing interval.

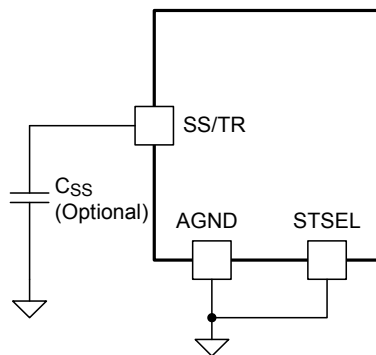

Figure 29. Slow-Start Capacitor (C_{SS}) And STSEL Connection

Table 6. Slow-Start Capacitor Values And Slow-Start Time

C_{SS} (nF)	OPEN	3.3	4.7	10	15	22	33
SS Time (msec)	1.2	2.1	2.5	3.8	5.1	7.0	9.8

7.3.16 Overcurrent Protection

For protection against load faults, the LMZ31710 incorporates output overcurrent protection. The overcurrent protection mode can be selected using the OCP_SEL pin. Leaving the OCP_SEL pin open selects hiccup mode and connecting it to AGND selects cycle-by-cycle mode. In hiccup mode, applying a load that exceeds the overcurrent threshold of the regulator causes the regulated output to shut down. Following shutdown, the module periodically attempts to recover by initiating a soft-start power-up as shown in Figure 30. This is described as a hiccup mode of operation, whereby the module continues in a cycle of successive shutdown and power up until the load fault is removed. During this period, the average current flowing into the fault is significantly reduced which reduces power dissipation. Once the fault is removed, the module automatically recovers and returns to normal operation as shown in Figure 31.

In cycle-by-cycle mode, applying a load that exceeds the regulator's overcurrent threshold limits the output current and reduces the output voltage as shown in Figure 32. During this period, the current flowing into the fault remains high causing the power dissipation to stay high as well. Once the overcurrent condition is removed, the output voltage returns to the set-point voltage as shown in Figure 33.

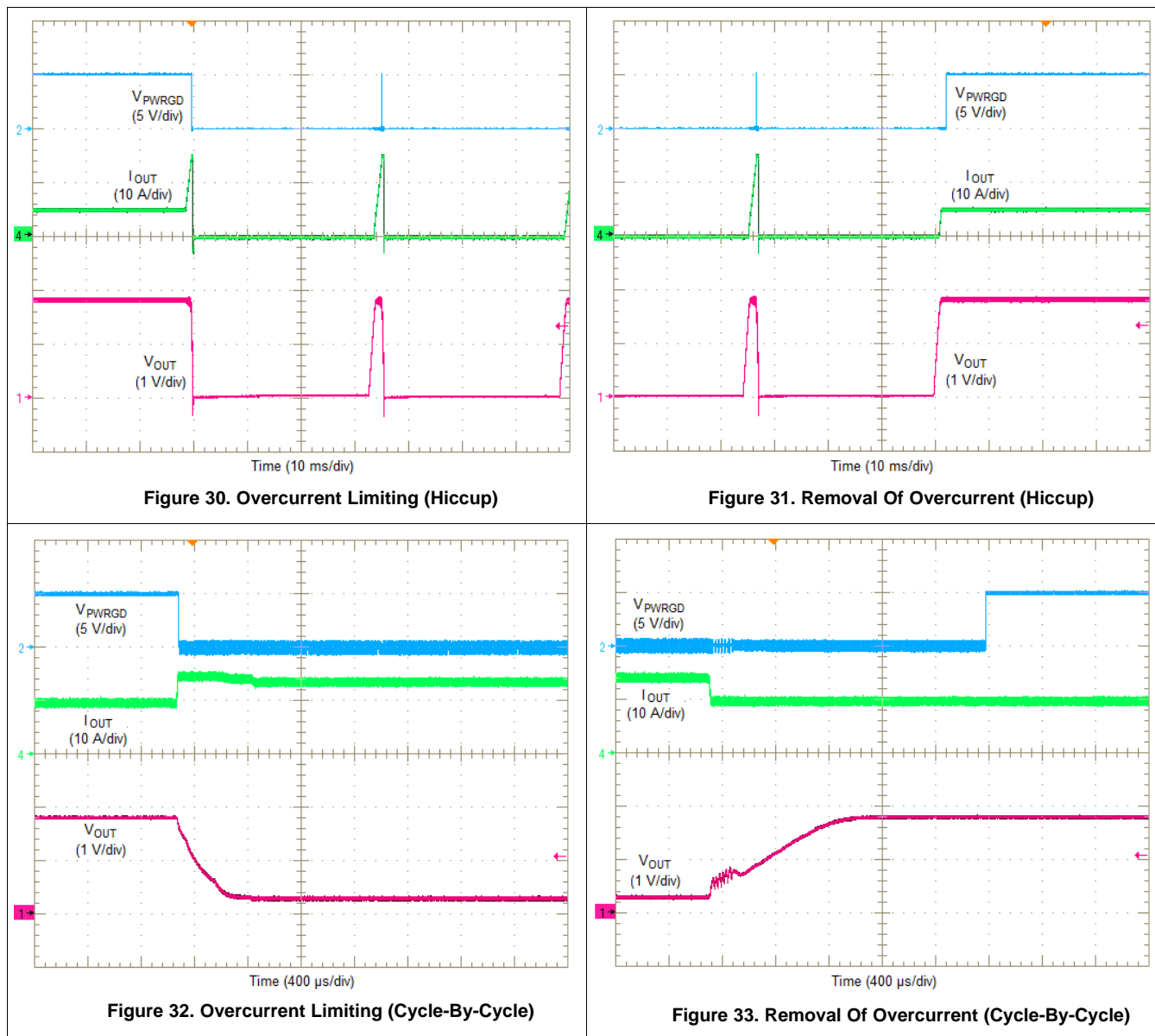

7.3.17 Synchronization (CLK)

An internal phase locked loop (PLL) has been implemented to allow synchronization between 200 kHz and 1200 kHz, and to easily switch from RT mode to CLK mode. To implement the synchronization feature, connect a square wave clock signal to the RT/CLK pin with a duty cycle between 20% to 80%. The clock signal amplitude must transition lower than 0.5 V and higher than 2 V. The start of the switching cycle is synchronized to the falling edge of RT/CLK pin. In applications where both RT mode and CLK mode are needed, the device can be configured as shown in [Figure 34](#).

Before the external clock is present, the device works in RT mode and the switching frequency is set by RT resistor. When the external clock is present, the CLK mode overrides the RT mode. The first time the CLK pin is pulled above the RT/CLK high threshold (2 V), the device switches from RT mode to CLK mode and the RT/CLK pin becomes high impedance as the PLL starts to lock onto the frequency of the external clock. It is not recommended to switch from CLK mode back to RT mode because the internal switching frequency drops to 100 kHz first before returning to the switching frequency set by the RT resistor (R_{RT}).

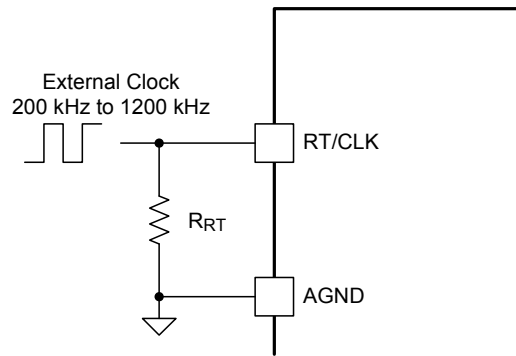

Figure 34. RT/CLK Configuration

The switching frequency must be selected based on the output voltages of the devices being synchronized. Table 7 shows the allowable frequencies for a given range of output voltages. The allowable switching frequency changes based on the maximum output current (I_{OUT}) of an application. The table shows the V_{OUT} range when $I_{OUT} \leq 10$ A, 9 A, and 8 A. For the most efficient solution, always synchronize to the lowest allowable frequency. For example, an application requires synchronizing three LMZ31710 devices with output voltages of 1.0 V, 1.2 V and 1.8 V, all powered from $P_{VIN} = 12$ V. Table 7 shows that all three output voltages must be synchronized to 300 kHz.

Table 7. Allowable Switching Frequency versus Output Voltage

SWITCHING FREQUENCY (kHz)	$P_{VIN} = 12$ V			$P_{VIN} = 5$ V		
	V_{OUT} RANGE (V)			V_{OUT} RANGE (V)		
	$I_{OUT} \leq 10$ A	$I_{OUT} \leq 9$ A	$I_{OUT} \leq 8$ A	$I_{OUT} \leq 10$ A	$I_{OUT} \leq 9$ A	$I_{OUT} \leq 8$ A
200	0.6 - 1.2	0.6 - 1.6	0.6 - 2.0	0.6 - 1.5	0.6 - 2.5	0.6 - 4.3
300	0.8 - 1.9	0.8 - 2.6	0.8 - 3.5	0.6 - 4.3	0.6 - 4.3	0.6 - 4.3
400	1.0 - 2.7	1.0 - 4.0	1.0 - 5.5	0.6 - 4.3	0.6 - 4.3	0.6 - 4.3
500	1.3 - 3.8	1.3 - 5.5	1.3 - 5.5	0.6 - 4.3	0.6 - 4.3	0.6 - 4.3
600	1.5 - 5.5	1.5 - 5.5	1.5 - 5.5	0.7 - 4.3	0.7 - 4.3	0.7 - 4.3
700	1.8 - 5.5	1.8 - 5.5	1.8 - 5.5	0.8 - 4.3	0.8 - 4.3	0.8 - 4.3
800	2.0 - 5.5	2.0 - 5.5	2.0 - 5.5	0.9 - 4.3	0.9 - 4.3	0.9 - 4.3
900	2.2 - 5.5	2.2 - 5.5	2.2 - 5.5	1.0 - 4.3	1.0 - 4.3	1.0 - 4.3
1000	2.5 - 5.5	2.5 - 5.5	2.5 - 5.5	1.1 - 4.3	1.1 - 4.3	1.1 - 4.3
1100	2.7 - 5.5	2.7 - 5.5	2.7 - 5.5	1.3 - 4.3	1.2 - 4.3	1.2 - 4.3
1200	3.0 - 5.5	3.0 - 5.5	3.0 - 5.5	1.4 - 4.3	1.3 - 4.3	1.3 - 4.3

7.3.18 Sequencing (SS/TR)

Many of the common power supply sequencing methods can be implemented using the SS/TR, INH and PWRGD pins. The sequential method is illustrated in Figure 35 using two LMZ31710 devices. The PWRGD pin of the first device is coupled to the INH pin of the second device which enables the second power supply once the primary supply reaches regulation. Figure 36 shows sequential turn-on waveforms of two LMZ31710 devices.

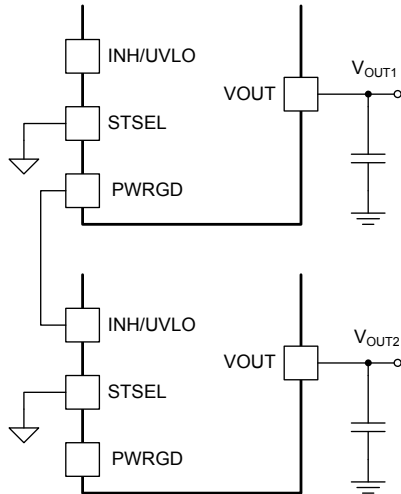

Figure 35. Sequencing Schematic

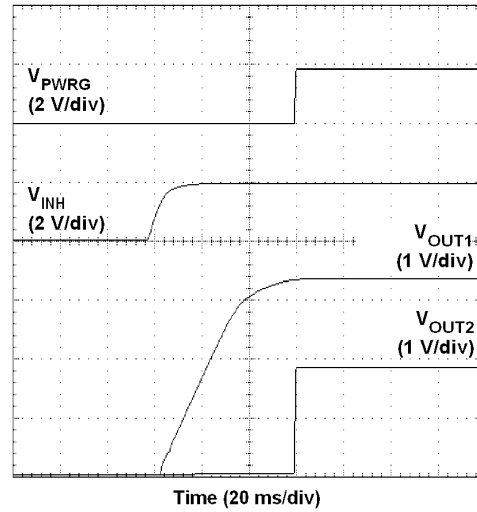

Figure 36. Sequencing Waveforms

Simultaneous power supply sequencing can be implemented by connecting the resistor network of R1 and R2 shown in Figure 37 to the output of the power supply that needs to be tracked or to another voltage reference source. The tracking voltage must exceed 750mV before V_{OUT2} reaches its set-point voltage. The PWRGD output of the V_{OUT2} device may remain low if the tracking voltage does not exceed 1.4 V. Figure 38 shows simultaneous turn-on waveforms of two LMZ31710 devices. Equation 3 and Equation 4 calculate the values of R1 and R2.

$$R1 = \frac{(V_{OUT2} \times 12.6)}{0.6} \text{ (k}\Omega\text{)} \tag{3}$$

$$R2 = \frac{0.6 \times R1}{(V_{OUT2} - 0.6)} \text{ (k}\Omega\text{)} \tag{4}$$

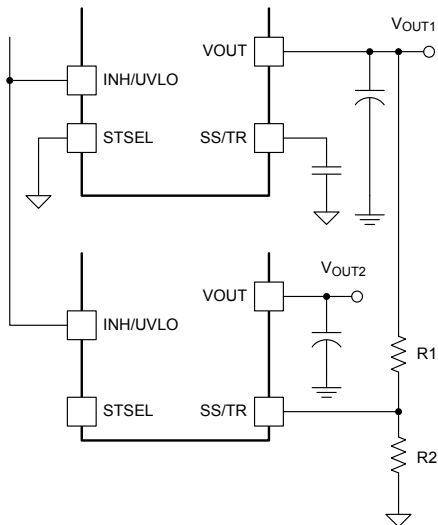

Figure 37. Simultaneous Tracking Schematic

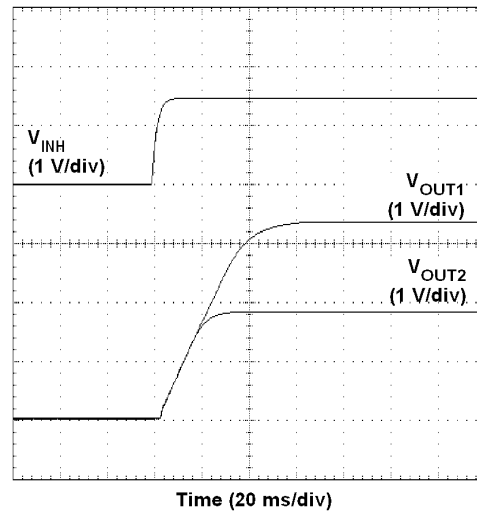

Figure 38. Simultaneous Tracking Waveforms

7.4 Device Functional Modes

7.4.1 Programmable Undervoltage Lockout (UVLO)

The LMZ31710 implements internal UVLO circuitry on the VIN pin. The device is disabled when the VIN pin voltage falls below the internal VIN UVLO threshold. The internal VIN UVLO rising threshold is 4.5 V(max) with a typical hysteresis of 150 mV.

If an application requires either a higher UVLO threshold on the VIN pin or a higher UVLO threshold for a combined VIN and PVIN, then the UVLO pin can be configured as shown in [Figure 39](#) or [Figure 40](#). [Table 8](#) lists standard values for R_{UVLO1} and R_{UVLO2} to adjust the VIN UVLO voltage up.

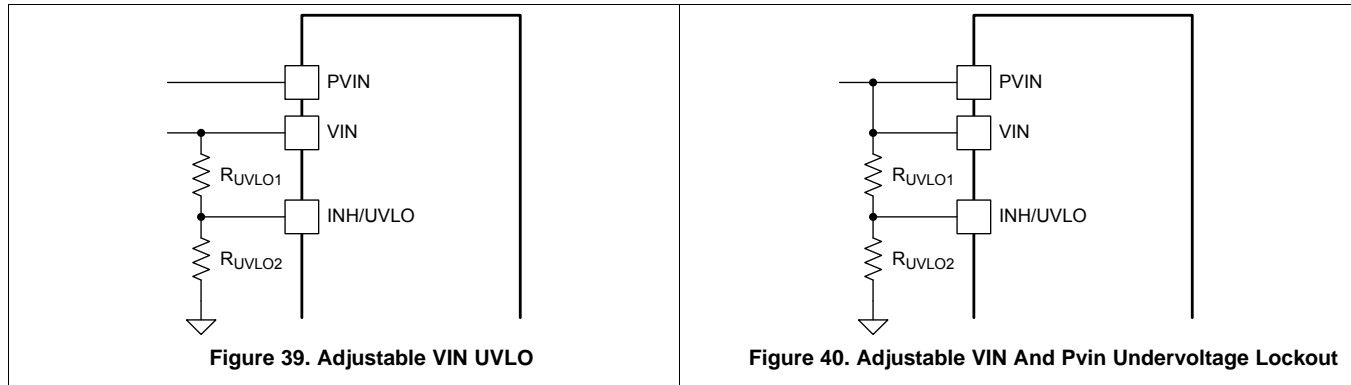

Table 8. Standard Resistor Values For Adjusting VIN UVLO

VIN UVLO (V)	5	5.5	6	6.5	7	7.5	8	8.5	9	9.5	10
R_{UVLO1} (k Ω)	68.1	68.1	68.1	68.1	68.1	68.1	68.1	68.1	68.1	68.1	68.1
R_{UVLO2} (k Ω)	21.5	18.7	16.9	15.4	14.0	13.0	12.1	11.3	10.5	9.76	9.31
Hysteresis (mV)	400	415	430	450	465	480	500	515	530	550	565

For a split rail application, if a secondary UVLO on PVIN is required, VIN must be ≥ 4.5 V. [Figure 41](#) shows the PVIN UVLO configuration. Use [Table 9](#) to select R_{UVLO1} and R_{UVLO2} for PVIN. If PVIN UVLO is set for less than 3.5 V, a 5.1-V zener diode must be added to clamp the voltage on the UVLO pin below 6 V.

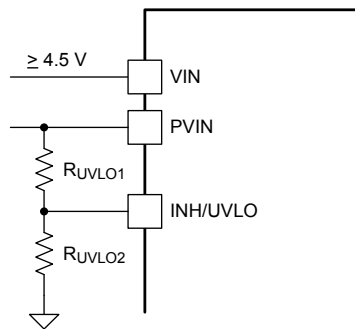

Figure 41. Adjustable PVIN Undervoltage Lockout, (VIN ≥ 4.5 V)

Table 9. Standard Resistor Values For Adjusting Pvin UVLO, (VIN ≥ 4.5 V)

PVIN UVLO (V)	2.9	3.0	3.5	4.0	4.5	For higher PVIN UVLO voltages, see Table 8 for resistor values
R_{UVLO1} (k Ω)	68.1	68.1	68.1	68.1	68.1	
R_{UVLO2} (k Ω)	47.5	44.2	34.8	28.7	24.3	
Hysteresis (mV)	330	335	350	365	385	

8 Application and Implementation

NOTE

Information in the following applications sections is not part of the TI component specification, and TI does not warrant its accuracy or completeness. TI's customers are responsible for determining suitability of components for their purposes. Customers should validate and test their design implementation to confirm system functionality.

8.1 Application Information

The LMZ31710 power module is an easy-to-use integrated power solution that combines a 10-A DC/DC converter with power MOSFETs, a shielded inductor, and passives into a low profile, QFN package. This total power solution allows as few as three external components and eliminates the loop compensation and magnetics part selection process.

8.2 Typical Application

A typical LMZ31710 application requires input and output capacitors, a voltage setting resistor, and a switching frequency setting resistor. [Figure 42](#) shows a typical LMZ31710 schematic with only the minimum required components.

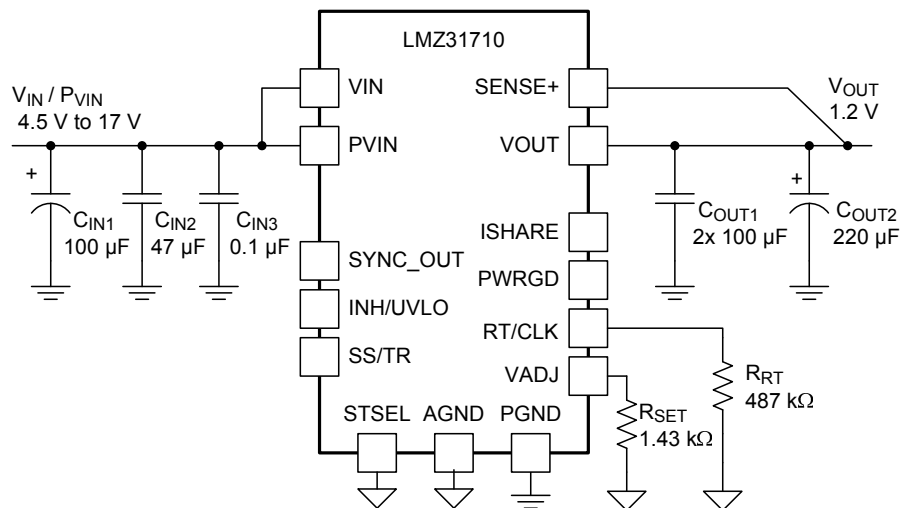

Figure 42. Typical Schematic
 $P_{VIN} = V_{IN} = 4.5 \text{ V To } 17 \text{ V}, V_{OUT} = 1.2 \text{ V}$

8.2.1 Design Requirements

For this design example, use the parameters listed in [Table 10](#) and follow these design procedures:

Table 10. Design Parameters

DESIGN PARAMETER	EXAMPLE VALUE
Input voltage	11.4 V to 12.6 V
Output voltage	1.2 V
Output current	10 A

8.2.2 Detailed Design Procedure

8.2.2.1 Custom Design With WEBENCH® Tools

[Click here](#) to create a custom design using the LMZ31710 device with the WEBENCH® Power Designer.

1. Start by entering the input voltage (V_{IN}), output voltage (V_{OUT}), and output current (I_{OUT}) requirements.
2. Optimize the design for key parameters such as efficiency, footprint, and cost using the optimizer dial.
3. Compare the generated design with other possible solutions from Texas Instruments.

The WEBENCH Power Designer provides a customized schematic along with a list of materials with real-time pricing and component availability.

In most cases, these actions are available:

- Run electrical simulations to see important waveforms and circuit performance
- Run thermal simulations to understand board thermal performance
- Export customized schematic and layout into popular CAD formats
- Print PDF reports for the design, and share the design with colleagues

Get more information about WEBENCH tools at www.ti.com/WEBENCH.

8.2.2.2 Setting The Output Voltage

The output voltage of the LMZ31710 is externally adjustable using a single resistor (R_{SET}). Select the value of R_{SET} from [Table 2](#) or calculate using [Equation 5](#).

$$R_{SET} = \frac{1.43}{\left(\left(\frac{V_{OUT}}{0.6}\right) - 1\right)} \text{ (k}\Omega\text{)} \quad (5)$$

To set the output voltage to 1.2 V, the calculated value for R_{SET} is 1.43 k Ω .

8.2.2.3 Setting the Switching Frequency

The recommended switching frequency for 1.2 V output voltage is 300 kHz. To set the switching frequency to 300 kHz, a 487 k Ω R_{RT} resistor is required. Refer to [Table 2](#) for recommended switching frequencies for other output voltages.

8.2.2.4 Input Capacitance

The minimum required input capacitance for the LMZ31710 is 44 μ F of ceramic capacitance. However, adding a 0.1 μ F ceramic capacitor placed directly at the input pins of the device will help with high frequency bypassing. Additionally, adding a bulk input capacitor is helpful in applications with fast changing load current.

In this application, a combination of a 100 μ F bulk capacitor, a 47 μ F ceramic capacitor, and a 0.1 μ F ceramic capacitor was used.

8.2.2.5 Output Capacitance

The amount of required output capacitance depends on the output voltage setting, as shown in [Table 3](#). For an output voltage of 1.2 V, the required minimum output capacitance is 200 μ F, with a requirement that at least 47 μ F must be ceramic type.

In this application, a combination of a 200 μ F of ceramic capacitance and a 220 μ F bulk capacitor was used. The additional 220 μ F bulk capacitor will help in applications with fast changing load current.

8.3 Additional Application Schematics

[Figure 43](#) and [Figure 44](#) show additional typical schematics. [Figure 43](#) shows a typical schematic for a 3.3 V output while P_{VIN} and V_{IN} are tied to the same input voltage rail. [Figure 44](#) shows a typical schematic for a 1.0 V output, however P_{VIN} and V_{IN} are powered from separate input voltage rails.

Additional Application Schematics (continued)

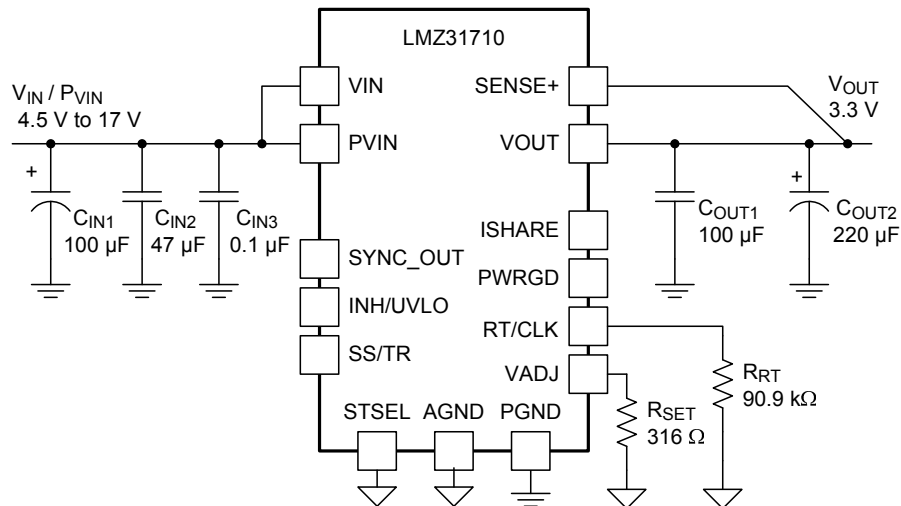

Figure 43. Typical Schematic
PVIN = VIN = 4.5 V To 17 V, Vout = 3.3 V

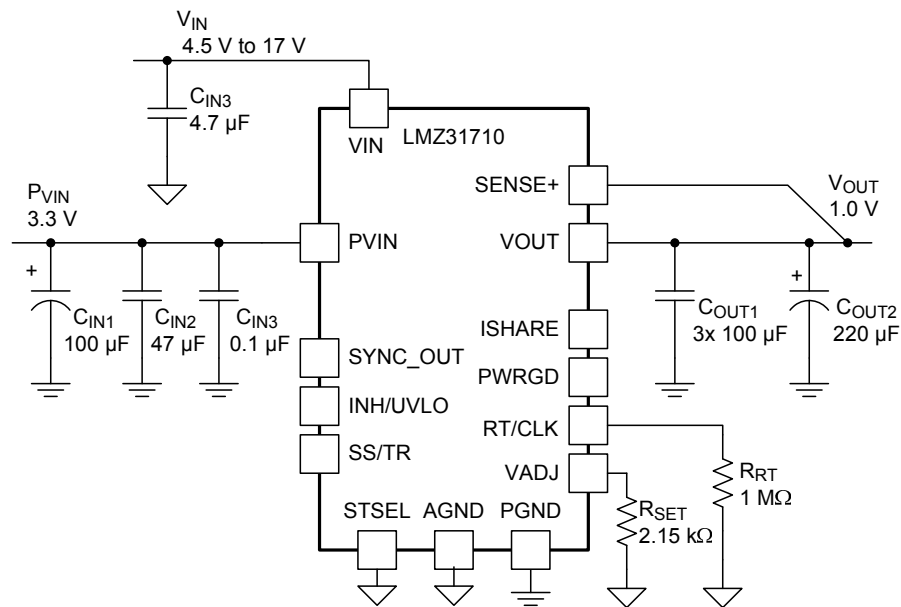

Figure 44. Typical Schematic
PVIN = 3.3 V, VIN = 4.5 V To 17 V, Vout = 1.0 V

9 Power Supply Recommendations

The LMZ31710 is designed to operate from an input voltage supply range between 2.95 V and 17 V. This input supply should be well regulated and able to withstand maximum input current and maintain a stable voltage. The resistance of the input supply rail should be low enough that an input current transient does not cause a high enough drop at the supply voltage that can cause a false UVLO fault triggering and system reset.

If the input supply is located more than a few inches from the LMZ31710, additional bulk capacitance may be required at the input pins. A typical recommended amount of bulk input capacitance is 47 µF - 100 µF.

10 Layout

10.1 Layout Considerations

To achieve optimal electrical and thermal performance, an optimized PCB layout is required. Figure 45 through Figure 48, shows a typical PCB layout. Some considerations for an optimized layout are:

- Use large copper areas for power planes (PVIN, VOUT, and PGND) to minimize conduction loss and thermal stress.
- Place ceramic input and output capacitors close to the device pins to minimize high frequency noise.
- Locate additional output capacitors between the ceramic capacitor and the load.
- Keep AGND and PGND separate from one another.
- Place R_{SET} , R_{RT} , and C_{SS} as close as possible to their respective pins.
- Use multiple vias to connect the power planes to internal layers.

10.2 Layout Examples

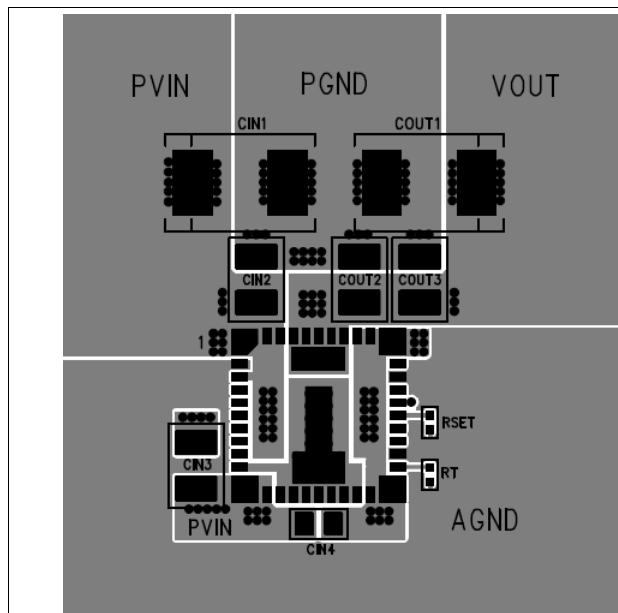

Figure 45. Typical Top-Layer Layout

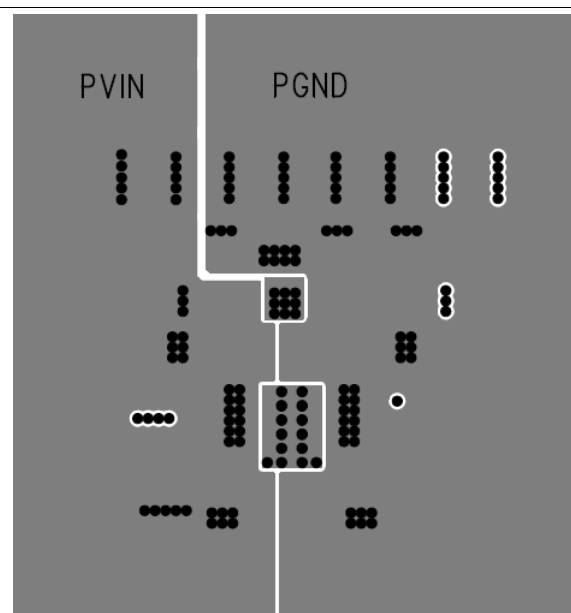
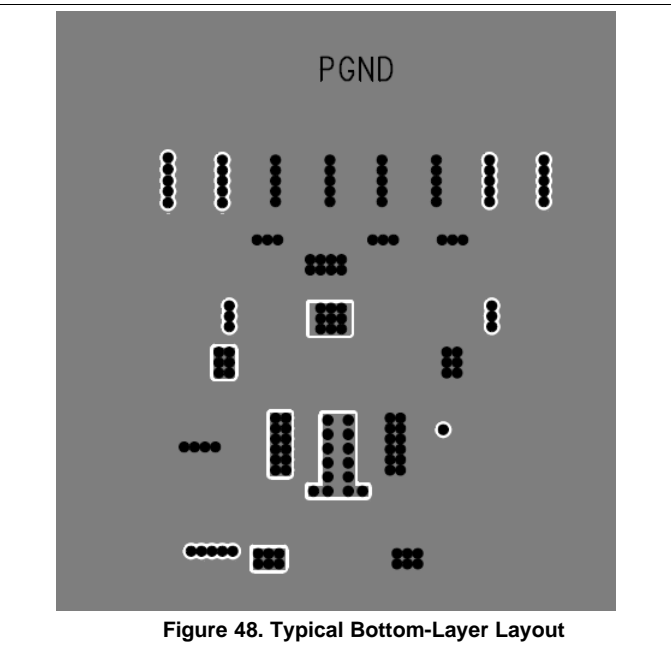
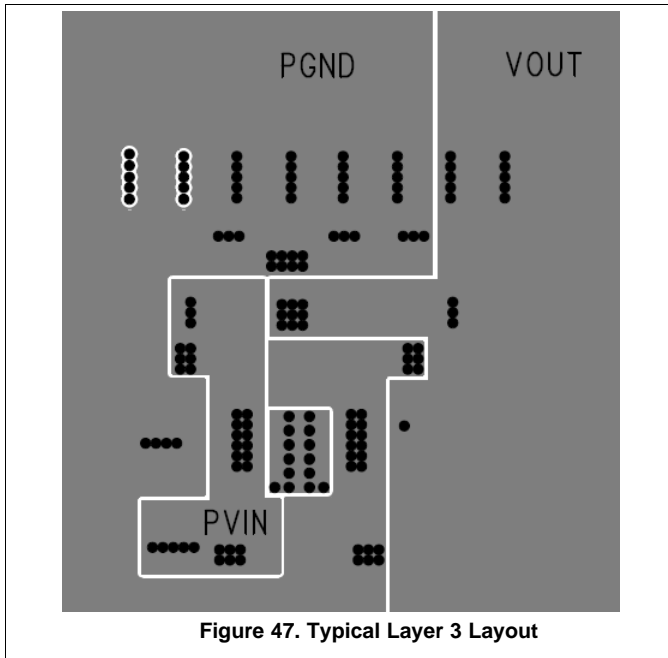

Figure 46. Typical Layer-2 Layout

Layout Examples (continued)



10.2.1 EMI

The LMZ31710 is compliant with EN55022 Class B radiated emissions. Figure 49 and Figure 50 show typical examples of radiated emissions plots for the LMZ31710 operating from 5 V and 12 V, respectively. Both graphs include the plots of the antenna in the horizontal and vertical positions.

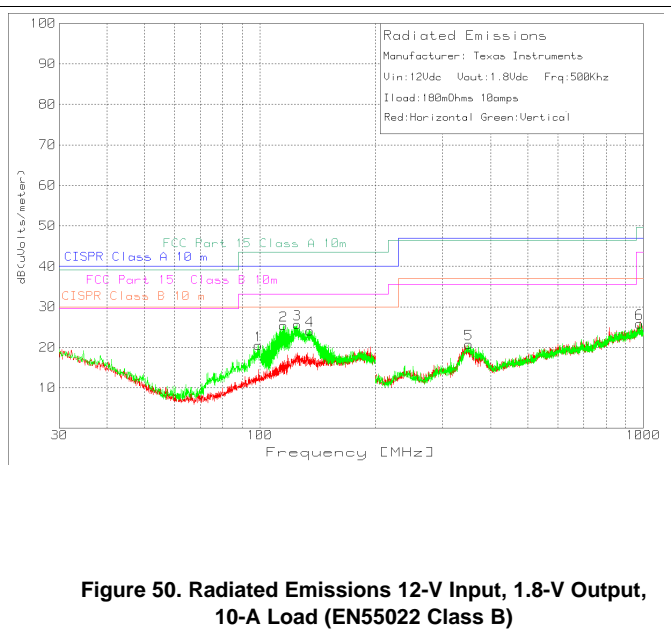
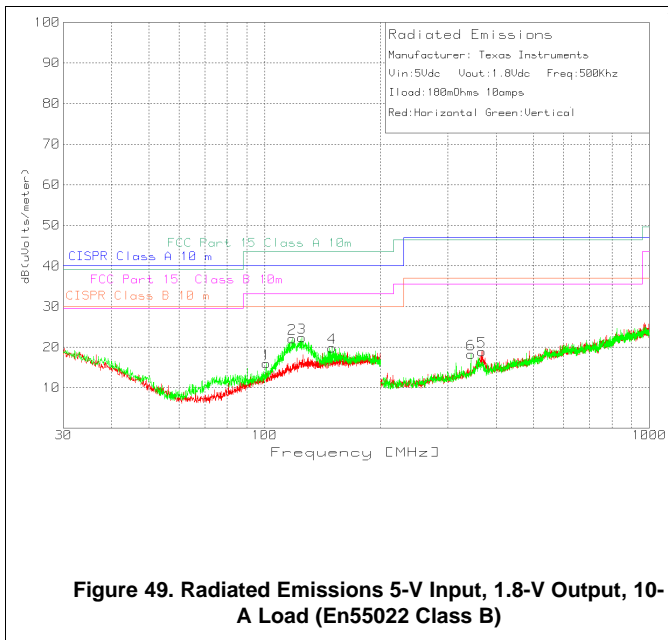

11 器件和文档支持

11.1 器件支持

11.1.1 开发支持

11.1.1.1 使用 **WEBENCH®** 工具创建定制设计

单击[此处](#)，使用 LMZ31710 器件并借助 WEBENCH® 电源设计器创建定制设计方案。

1. 首先输入输入电压 (V_{IN})、输出电压 (V_{OUT}) 和输出电流 (I_{OUT}) 要求。
2. 使用优化器拨盘优化该设计的关键参数，如效率、尺寸和成本。
3. 将生成的设计与德州仪器 (TI) 的其他可行的解决方案进行比较。

WEBENCH 电源设计器可提供定制原理图以及罗列实时价格和组件供货情况的物料清单。

在多数情况下，可执行以下操作：

- 运行电气仿真，观察重要波形以及电路性能
- 运行热性能仿真，了解电路板热性能
- 将定制原理图和布局方案以常用 CAD 格式导出
- 打印设计方案的 PDF 报告并与同事共享

有关 WEBENCH 工具的详细信息，请访问 www.ti.com.cn/WEBENCH。

11.1.2 第三方产品免责声明

TI 发布的与第三方产品或服务有关的信息，不能构成与此类产品或服务或保修的适用性有关的认可，不能构成此类产品或服务单独或与任何 TI 产品或服务一起的表示或认可。

11.2 文档支持

11.2.1 相关文档

请参阅如下相关文档：

- 德州仪器 (TI)，[LMZ31710 EVM 用户指南](#)
- 德州仪器 (TI)，[《LMZ31710 并行 EVM 用户指南》](#)
- 德州仪器 (TI)，[LMZ31707 \(7A\) 数据表](#)
- 德州仪器 (TI)，[LMZ31704 \(4A\) 数据表](#)
- 德州仪器 (TI)，[《BQFN 封装的焊接要求》](#)

11.3 接收文档更新通知

要接收文档更新通知，请导航至 ti.com 上的器件产品文件夹。单击右上角的[通知我](#)进行注册，即可每周接收产品信息更改摘要。有关更改的详细信息，请查看任何已修订文档中包含的修订历史记录。

11.4 支持资源

TI E2E™ [support forums](#) are an engineer's go-to source for fast, verified answers and design help — straight from the experts. Search existing answers or ask your own question to get the quick design help you need.

Linked content is provided "AS IS" by the respective contributors. They do not constitute TI specifications and do not necessarily reflect TI's views; see TI's [Terms of Use](#).

11.5 商标

Eco-Mode, E2E are trademarks of Texas Instruments.
All other trademarks are the property of their respective owners.

11.6 静电放电警告



这些装置包含有限的内置 ESD 保护。存储或装卸时，应将导线一起截短或将装置放置于导电泡棉中，以防止 MOS 门极遭受静电损伤。

11.7 Glossary

SLYZ022 — TI Glossary.

This glossary lists and explains terms, acronyms, and definitions.

12 机械、封装和可订购信息

以下页面包含机械、封装和可订购信息。这些信息是指定器件的最新可用数据。数据如有变更，恕不另行通知，且不会对此文档进行修订。如需获取此数据表的浏览器版本，请查阅左侧的导航栏。

12.1 Tape and Reel Information

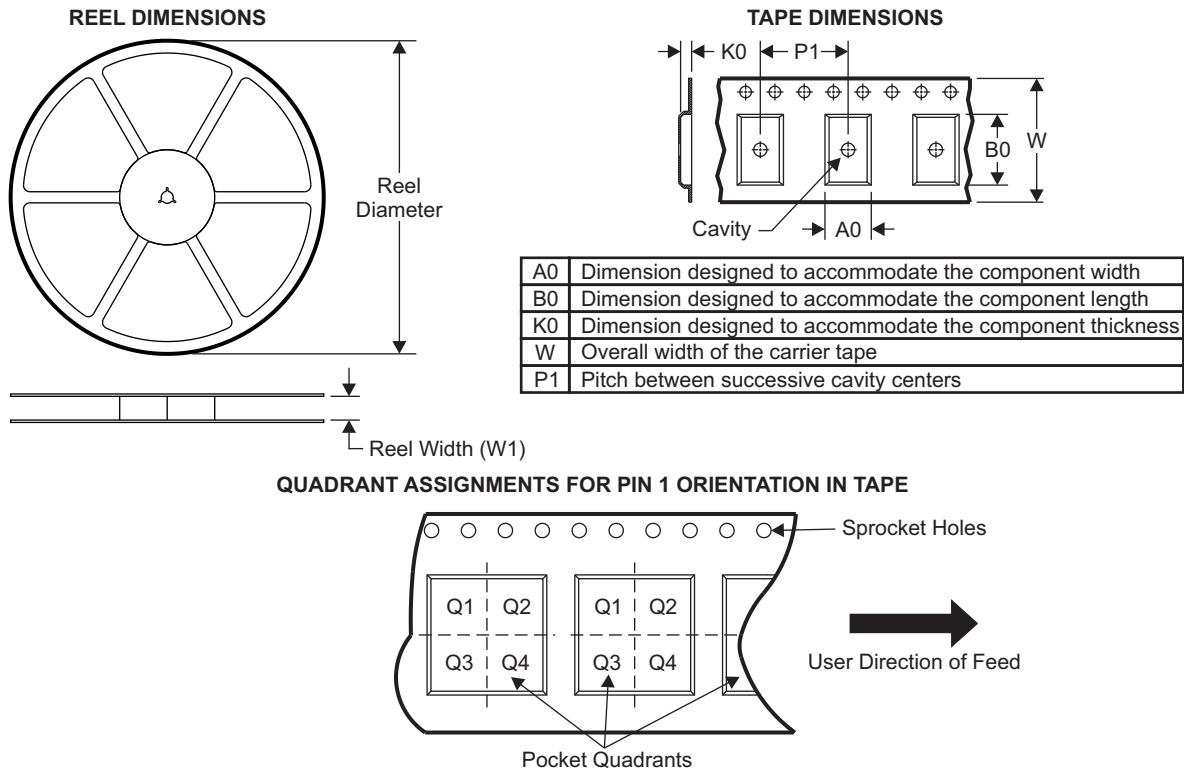

Device	Package Type	Package Drawing	Pins	SPQ	Reel Diameter (mm)	Reel Width W1 (mm)	A0 (mm)	B0 (mm)	K0 (mm)	P1 (mm)	W (mm)	Pin1 Quadrant
LMZ31710RVQR	B3QFN	RVQ	42	500	330.0	24.4	10.35	10.35	4.6	16.0	24.0	Q2
LMZ31710RVQT	B3QFN	RVQ	42	250	330.0	24.4	10.35	10.35	4.6	16.0	24.0	Q2

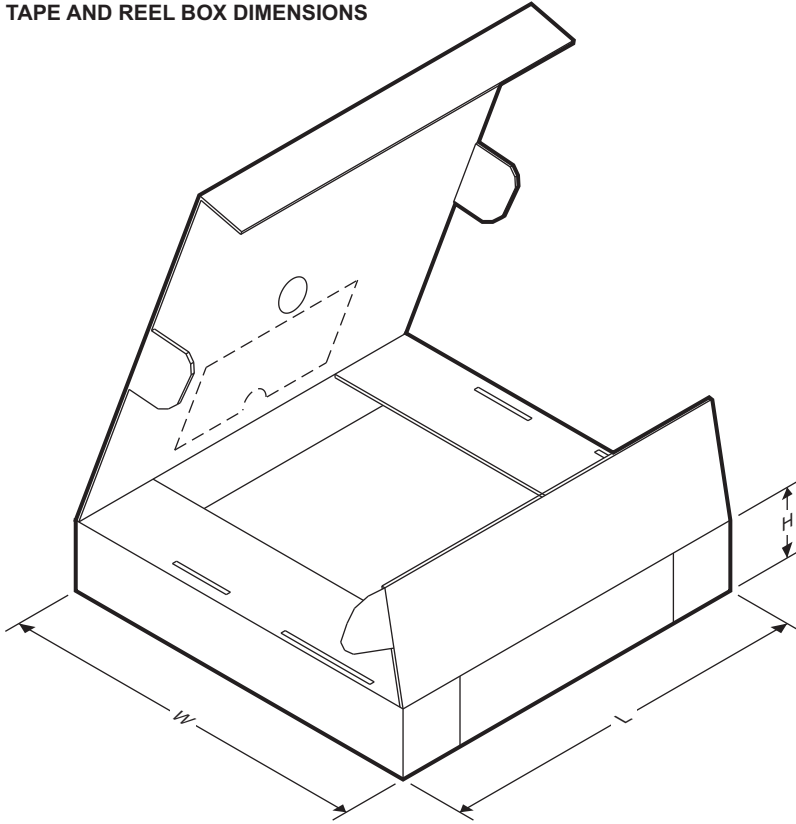

LMZ31710

ZHCSBC7E – JULY 2013 – REVISED DECEMBER 2019

www.ti.com.cn
TAPE AND REEL BOX DIMENSIONS

Device	Package Type	Package Drawing	Pins	SPQ	Length (mm)	Width (mm)	Height (mm)
LMZ31710RVQR	B3QFN	RVQ	42	500	383.0	353.0	58.0
LMZ31710RVQT	B3QFN	RVQ	42	250	383.0	353.0	58.0

PACKAGING INFORMATION

Orderable Device	Status (1)	Package Type	Package Drawing	Pins	Package Qty	Eco Plan (2)	Lead finish/ Ball material (6)	MSL Peak Temp (3)	Op Temp (°C)	Device Marking (4/5)	Samples
LMZ31710RVQR	ACTIVE	B3QFN	RVQ	42	500	RoHS Exempt & Green	NIPDAU	Level-3-245C-168 HR	-40 to 85	(54020, LMZ31710)	
LMZ31710RVQT	ACTIVE	B3QFN	RVQ	42	250	RoHS Exempt & Green	NIPDAU	Level-3-245C-168 HR	-40 to 85	(54020, LMZ31710)	

(1) The marketing status values are defined as follows:

ACTIVE: Product device recommended for new designs.

LIFEBUY: TI has announced that the device will be discontinued, and a lifetime-buy period is in effect.

NRND: Not recommended for new designs. Device is in production to support existing customers, but TI does not recommend using this part in a new design.

PREVIEW: Device has been announced but is not in production. Samples may or may not be available.

OBsolete: TI has discontinued the production of the device.

(2) **RoHS:** TI defines "RoHS" to mean semiconductor products that are compliant with the current EU RoHS requirements for all 10 RoHS substances, including the requirement that RoHS substance do not exceed 0.1% by weight in homogeneous materials. Where designed to be soldered at high temperatures, "RoHS" products are suitable for use in specified lead-free processes. TI may reference these types of products as "Pb-Free".

RoHS Exempt: TI defines "RoHS Exempt" to mean products that contain lead but are compliant with EU RoHS pursuant to a specific EU RoHS exemption.

Green: TI defines "Green" to mean the content of Chlorine (Cl) and Bromine (Br) based flame retardants meet JS709B low halogen requirements of <=1000ppm threshold. Antimony trioxide based flame retardants must also meet the <=1000ppm threshold requirement.

(3) MSL, Peak Temp. - The Moisture Sensitivity Level rating according to the JEDEC industry standard classifications, and peak solder temperature.

(4) There may be additional marking, which relates to the logo, the lot trace code information, or the environmental category on the device.

(5) Multiple Device Markings will be inside parentheses. Only one Device Marking contained in parentheses and separated by a "~" will appear on a device. If a line is indented then it is a continuation of the previous line and the two combined represent the entire Device Marking for that device.

(6) Lead finish/Ball material - Orderable Devices may have multiple material finish options. Finish options are separated by a vertical ruled line. Lead finish/Ball material values may wrap to two lines if the finish value exceeds the maximum column width.

Important Information and Disclaimer:The information provided on this page represents TI's knowledge and belief as of the date that it is provided. TI bases its knowledge and belief on information provided by third parties, and makes no representation or warranty as to the accuracy of such information. Efforts are underway to better integrate information from third parties. TI has taken and continues to take reasonable steps to provide representative and accurate information but may not have conducted destructive testing or chemical analysis on incoming materials and chemicals. TI and TI suppliers consider certain information to be proprietary, and thus CAS numbers and other limited information may not be available for release.

In no event shall TI's liability arising out of such information exceed the total purchase price of the TI part(s) at issue in this document sold by TI to Customer on an annual basis.

TAPE AND REEL INFORMATION

QUADRANT ASSIGNMENTS FOR PIN 1 ORIENTATION IN TAPE

*All dimensions are nominal

Device	Package Type	Package Drawing	Pins	SPQ	Reel Diameter (mm)	Reel Width W1 (mm)	A0 (mm)	B0 (mm)	K0 (mm)	P1 (mm)	W (mm)	Pin1 Quadrant
LMZ31710RVQR	B3QFN	RVQ	42	500	330.0	24.4	10.35	10.35	4.6	16.0	24.0	Q2
LMZ31710RVQT	B3QFN	RVQ	42	250	330.0	24.4	10.35	10.35	4.6	16.0	24.0	Q2

TAPE AND REEL BOX DIMENSIONS

*All dimensions are nominal

Device	Package Type	Package Drawing	Pins	SPQ	Length (mm)	Width (mm)	Height (mm)
LMZ31710RVQR	B3QFN	RVQ	42	500	383.0	353.0	58.0
LMZ31710RVQT	B3QFN	RVQ	42	250	383.0	353.0	58.0

PACKAGE OUTLINE

RVQ0042A

B3QFN - 4.4 mm max height

SUPER THICK QUAD FLATPACK - NO LEAD

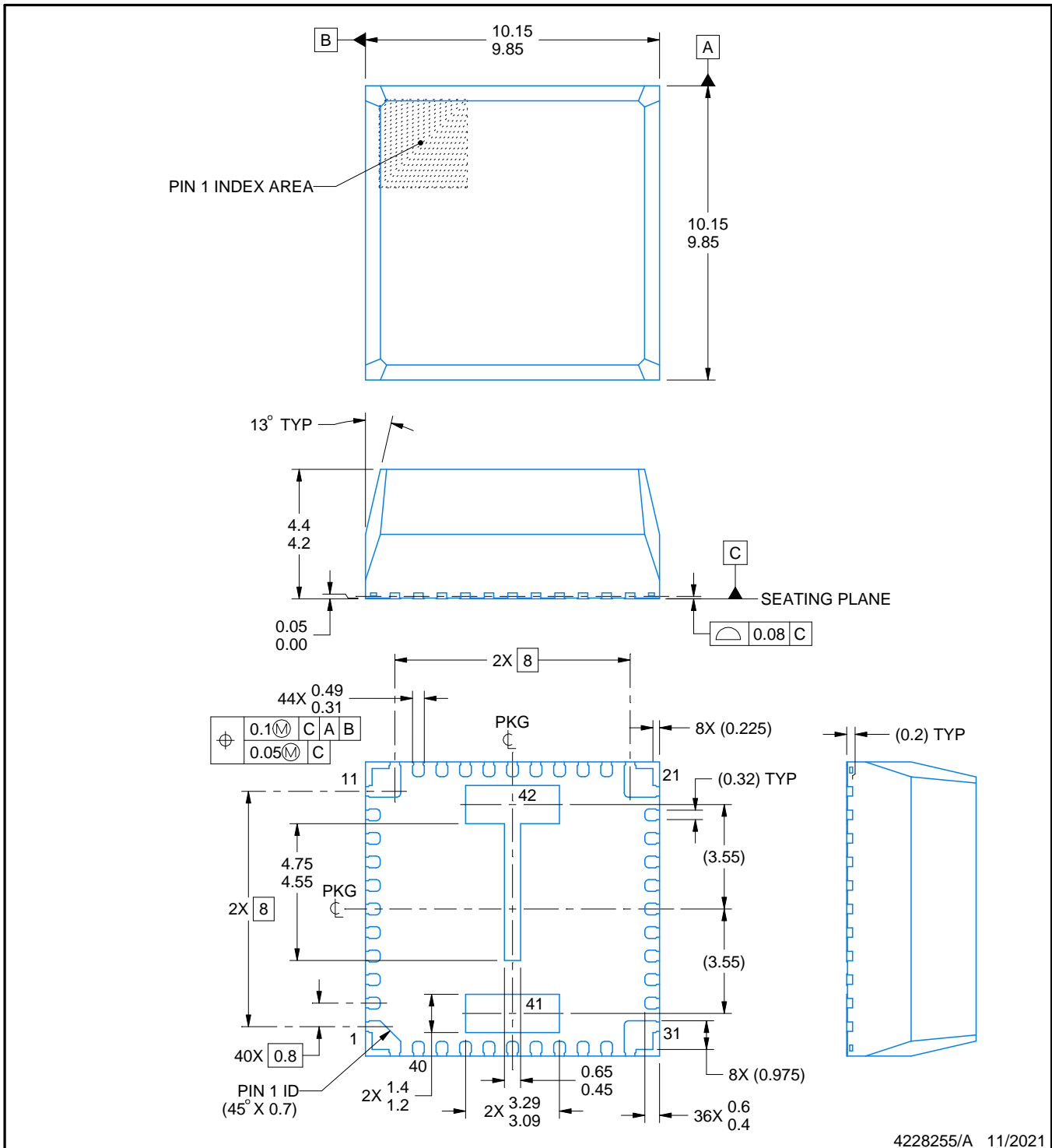

NOTES:

1. All linear dimensions are in millimeters. Any dimensions in parenthesis are for reference only. Dimensioning and tolerancing per ASME Y14.5M.
2. This drawing is subject to change without notice.
3. The package thermal pad must be soldered to the printed circuit board for thermal and mechanical performance.

EXAMPLE BOARD LAYOUT

RVQ0042A

B3QFN - 4.4 mm max height

SUPER THICK QUAD FLATPACK - NO LEAD

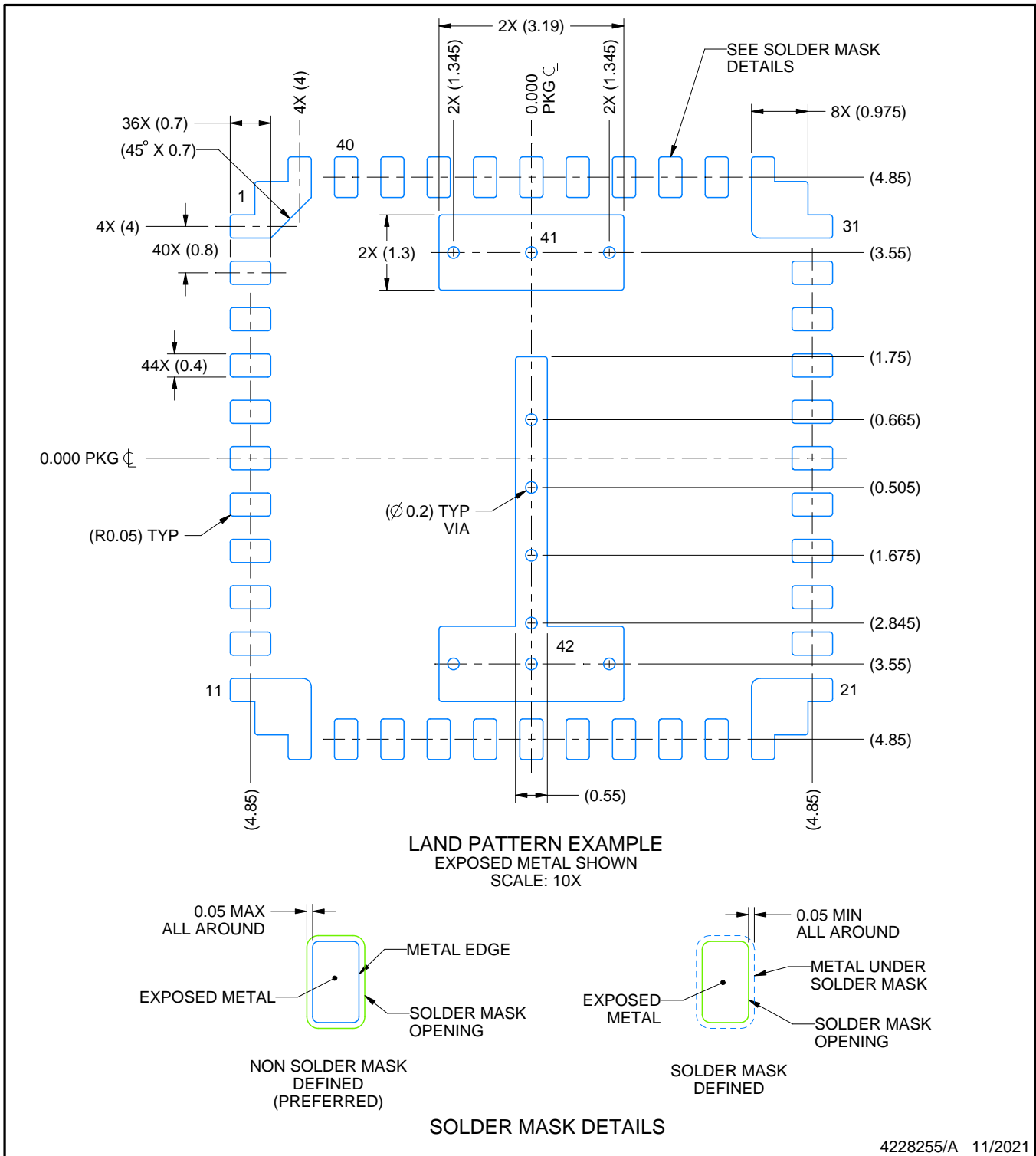

4228255/A 11/2021

NOTES: (continued)

- This package is designed to be soldered to a thermal pad on the board. For more information, see Texas Instruments literature number SLUA271 (www.ti.com/lit/slua271).
- Vias are optional depending on application, refer to device data sheet. If any vias are implemented, refer to their locations shown on this view. It is recommended that vias under paste be filled, plugged or tented.

EXAMPLE STENCIL DESIGN

RVQ0042A

B3QFN - 4.4 mm max height

SUPER THICK QUAD FLATPACK - NO LEAD

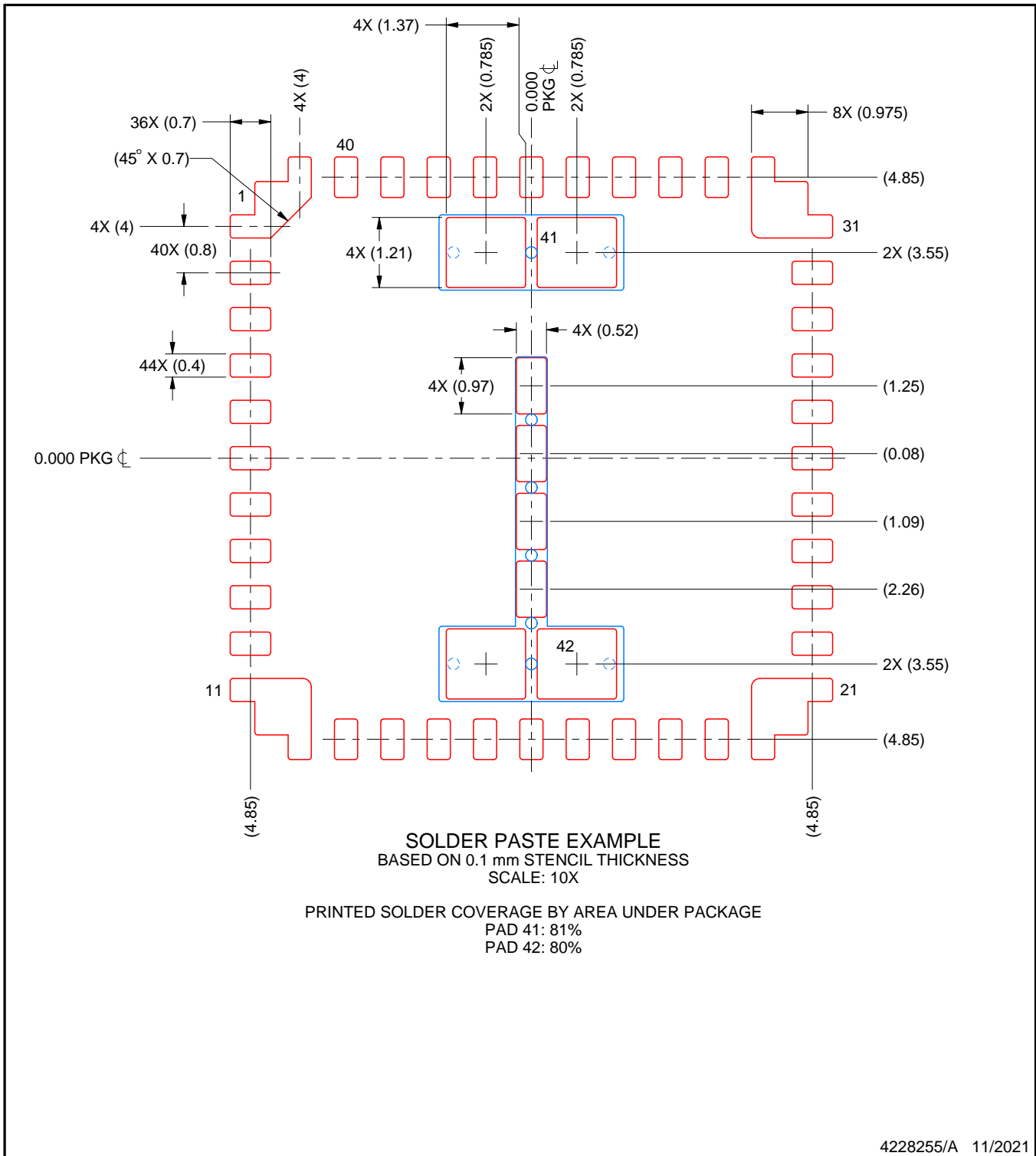

NOTES: (continued)

6. Laser cutting apertures with trapezoidal walls and rounded corners may offer better paste release. IPC-7525 may have alternate design recommendations.

重要声明和免责声明

TI“按原样”提供技术和可靠性数据（包括数据表）、设计资源（包括参考设计）、应用或其他设计建议、网络工具、安全信息和其他资源，不保证没有瑕疵且不做任何明示或暗示的担保，包括但不限于对适销性、某特定用途方面的适用性或不侵犯任何第三方知识产权的暗示担保。

这些资源可供使用 TI 产品进行设计的熟练开发人员使用。您将自行承担以下全部责任：(1) 针对您的应用选择合适的 TI 产品，(2) 设计、验证并测试您的应用，(3) 确保您的应用满足相应标准以及任何其他功能安全、信息安全、监管或其他要求。

这些资源如有变更，恕不另行通知。TI 授权您仅可将这些资源用于研发本资源所述的 TI 产品的应用。严禁对这些资源进行其他复制或展示。您无权使用任何其他 TI 知识产权或任何第三方知识产权。您应全额赔偿因在这些资源的使用中对 TI 及其代表造成的任何索赔、损害、成本、损失和债务，TI 对此概不负责。

TI 提供的产品受 [TI 的销售条款](#) 或 [ti.com](#) 上其他适用条款/TI 产品随附的其他适用条款的约束。TI 提供这些资源并不会扩展或以其他方式更改 TI 针对 TI 产品发布的适用的担保或担保免责声明。

TI 反对并拒绝您可能提出的任何其他或不同的条款。

邮寄地址：Texas Instruments, Post Office Box 655303, Dallas, Texas 75265
Copyright © 2021，德州仪器 (TI) 公司

X-ON Electronics

Largest Supplier of Electrical and Electronic Components

Click to view similar products for [Non-Isolated DC/DC Converters](#) category:

Click to view products by [Texas Instruments](#) manufacturer:

Other Similar products are found below :

[DP8160G-S1-R1](#) [APTH003A0X-SRZ](#) [CA-17205-L4](#) [PROPOWER-3.3V](#) [JRCS016A0S4-HZ](#) [VI-920194B](#) [T31SN24005NMFA](#) [RPX-4.0-R](#)
[TPSM5D1806RDBR](#) [XC9291B33E0R-G](#) [R-78K1.2-2.0L](#) [RPMGS12-20](#) [R-78K15-1.0](#) [R-78K2.5-2.0L](#) [R-78K15-2.0](#) [RGA4W250W010A-003](#)
[R-78K5.0-0.5](#) [R-78K9.0-1.0](#) [RPX-0.5Q-R](#) [R-78K1.8-0.5](#) [RPMGQ12-20](#) [R-78K1.8-1.0](#) [R-78K2.5-0.5](#) [R-78K1.5-0.5](#) [RGC4W300W008A-001](#)
[R-78K12-0.5](#) [R-78K2.5-2.0](#) [R-78K1.2-2.0](#) [R-78K9.0-2.0L](#) [R-78K1.8-2.0L](#) [R-78K1.5-2.0L](#) [RGA24250W014A-001](#) [RGC4W300W012A-001](#)
[R-78K9.0-2.0](#) [RPMGS5.0-20](#) [RGC4W300W012A-003](#) [RPY-1.5Q-R](#) [R-78K3.3-1.0](#) [R-78K1.8-2.0](#) [RGA4W250W010A-001](#) [R-78K3.3-2.0L](#)
[R-78CK12-0.5](#) [R-78K2.5-1.0](#) [R-78K12-1.0](#) [R-78K1.5-2.0](#) [RGC4W300W008A-003](#) [RGA24250W014A-003](#) [R-78K3.3-2.0](#) [BM2P134QF-E2](#)
[PTV03020WAH](#)