

LP5810 4-Channel RGBW LED Driver with Autonomous Control

1 Features

- Operating voltage range:
 - V_{CC} range: 2.7 V to 5.5 V
 - Logic pins compatible with 1.8 V, 3.3 V, and 5 V
- 4 constant current sinks with high precision:
 - 0.1-mA to 51-mA per current sink
 - Device-to-device error: max $\pm 5\%$
 - Channel-to-channel error: max $\pm 5\%$
 - Ultra-low headroom voltage: 110 mV (typ.) at 25.5 mA; 210 mV (typ.) at 51 mA
 - PWM phase shift configurable for each LED
- Ultra-low power consumption:
 - Standby: $I_{STB} = 26 \mu\text{A}$ (typical) when $\text{CHIP_EN} = 0$ (data retained)
 - Active: $I_{NOR} = 0.4 \text{ mA}$ (typical) when LED current = 25.5 mA
- Analog dimming (current gain control)
 - Global 1-bit Maximum Current (MC): 25.5 mA or 51 mA
 - Individual 8-bit Dot Current (DC) setting
- PWM dimming up to audible-noise-free 24 kHz
 - Individual 8-bit PWM dimming resolution
 - Linear or exponential dimming curves
- Autonomous animation engine control
- Individual LED dot open/short detection
- Integrated de-ghosting function
- 1-MHz (max.) I²C interface
- 40°C to 85°C operating temperature range

2 Applications

LED animation and indication for:

- Portable and wearable electronics - earbud and charging case, E-cigarette, smart watch
- Gaming and home entertainment - smart speaker, RGB mouse, VR headset, and controller
- Internet-of-Things (IOT) - E-tag, video doorbell
- Networkings - router, access point
- Industrial HMI - EV charger, factory automation

3 Description

The LP5810 is a 4-channel RGBW LED driver with autonomous animation engine control. The device has ultra-low normal operation current with 0.4-mA (typical) when illuminate LEDs.

Both analog dimming and PWM dimming methods are adopted to achieve powerful dimming performance. The output current of each LED can be adjusted with 256 steps from 0.1 mA to 25.5 mA or 0.2 mA to 51 mA. The 8-bit PWM generator enables smooth and audible-noise-free dimming control for LED brightness.

The autonomous animation engine can significantly reduce the real-time loading of controller. Each LED can be configured through the related registers to realize vivid and fancy lighting effects. The device can generate 6-MHz clock signal and use it for synchronizing the lighting effects among multiple devices.

Package Information

| PART NUMBER | PACKAGE ⁽¹⁾ | BODY SIZE (NOM) |
|-------------|------------------------|-------------------|
| LP5810 | DSBGA (9) | 1.43 mm × 1.43 mm |
| | WSO8 (8) | 3 mm × 3 mm |

(1) Product Preview

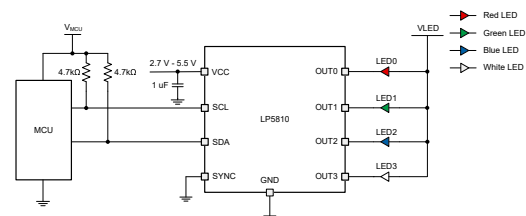

Simplified Schematic



Table of Contents

| | | | |
|------------------------------------------------|----|------------------------------------------------------------------|----|
| 1 Features | 1 | 8.5 Programming..... | 18 |
| 2 Applications | 1 | 9 Register Maps | 20 |
| 3 Description | 1 | 10 Application and Implementation | 22 |
| 4 Device Comparison | 3 | 10.1 Application Information..... | 22 |
| 5 Pin Configuration and Functions | 4 | 10.2 Typical Application..... | 22 |
| 6 Specifications | 5 | 10.3 Power Supply Recommendations..... | 27 |
| 6.1 Absolute Maximum Ratings..... | 5 | 10.4 Layout..... | 27 |
| 6.2 ESD Ratings..... | 5 | 11 Device and Documentation Support | 29 |
| 6.3 Recommended Operating Conditions..... | 6 | 11.1 Documentation Support..... | 29 |
| 6.4 Thermal Information..... | 6 | 11.2 Receiving Notification of Documentation Updates.. | 29 |
| 6.5 Electrical Characteristics..... | 7 | 11.3 Support Resources..... | 29 |
| 6.6 Timing Requirements..... | 10 | 11.4 Trademarks..... | 29 |
| 7 Typical Characteristics | 11 | 11.5 Electrostatic Discharge Caution..... | 29 |
| 8 Detailed Description | 12 | 11.6 Glossary..... | 29 |
| 8.1 Overview..... | 12 | 12 Revision History | 29 |
| 8.2 Functional Block Diagram..... | 12 | 13 Mechanical, Packaging, and Orderable Information | 30 |
| 8.3 Feature Description..... | 12 | | |
| 8.4 Device Functional Modes..... | 17 | | |

4 Device Comparison

| PART NUMBER | Max LED Number | Power Stage | PACKAGE | MATERIAL | I ² C Chip Address | | SOFTWARE COMPATIBLE |
|-------------|----------------|-------------|----------|-------------|-------------------------------|-------|---------------------|
| | | | | | Bit 4 | Bit 3 | |
| LP5813 | 12 | Boost | DSBGA-12 | LP5813AYBHR | 0 | 0 | Yes |
| | | | | LP5813BYBHR | 0 | 1 | |
| | | | | LP5813CYBHR | 1 | 0 | |
| | | | | LP5813DYBHR | 1 | 1 | |
| | | | WSON-12 | LP5813ADRRR | 0 | 0 | |
| | | | | LP5813BDRRR | 0 | 1 | |
| | | | | LP5813CDRRR | 1 | 0 | |
| | | | | LP5813DDRRR | 1 | 1 | |
| LP5812 | 12 | Linear | DSBGA-9 | LP5812AYBHR | 0 | 0 | |
| | | | | LP5812BYBHR | 0 | 1 | |
| | | | | LP5812CYBHR | 1 | 0 | |
| | | | | LP5812DYBHR | 1 | 1 | |
| | | | WSON-8 | LP5812ADSDR | 0 | 0 | |
| | | | | LP5812BDSDR | 0 | 1 | |
| | | | | LP5812CDSDR | 1 | 0 | |
| | | | | LP5812DDSDR | 1 | 1 | |
| LP5811 | 4 | Boost | DSBGA-12 | LP5811AYBHR | 0 | 0 | |
| | | | | LP5811BYBHR | 0 | 1 | |
| | | | | LP5811CYBHR | 1 | 0 | |
| | | | | LP5811DYBHR | 1 | 1 | |
| | | | WSON-12 | LP5811ADRRR | 0 | 0 | |
| | | | | LP5811BDRRR | 0 | 1 | |
| | | | | LP5811CDRRR | 1 | 0 | |
| | | | | LP5811DDRRR | 1 | 1 | |
| LP5810 | 4 | Linear | DSBGA-9 | LP5810AYBHR | 0 | 0 | |
| | | | | LP5810BYBHR | 0 | 1 | |
| | | | | LP5810CYBHR | 1 | 0 | |
| | | | | LP5810DYBHR | 1 | 1 | |
| | | | WSON-8 | LP5810ADSDR | 0 | 0 | |
| | | | | LP5810BDSDR | 0 | 1 | |
| | | | | LP5810CDSDR | 1 | 0 | |
| | | | | LP5810DDSDR | 1 | 1 | |

5 Pin Configuration and Functions

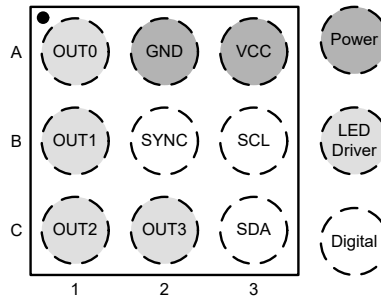

Figure 5-1. LP5810 YBH Package 9-Pin DSBGA Top View

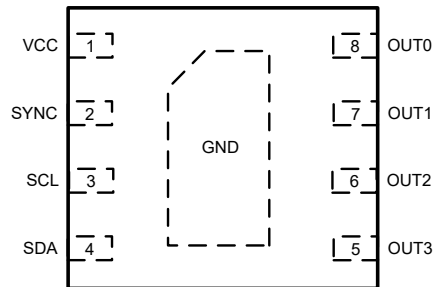

Figure 5-2. LP5810 DSD Package 8-Pin WSON Top View

Table 5-1. Pin Functions

| NAME | PIN | | TYPE ⁽¹⁾ | DESCRIPTION |
|------|-----|-------------|---------------------|------------------------------------------------------------------------------------------------------|
| | YBH | DSD | | |
| OUT0 | A1 | 8 | O | Current sink 0. If not used, this pin can be floating or connecting to GND. |
| GND | A2 | Thermal pad | G | Ground. This pin must connect to the ground plane. |
| VCC | A3 | 1 | P | Power supply of the device. |
| OUT1 | B1 | 7 | O | Current sink 1. If not used, this pin can be floating or connecting to GND. |
| SYNC | B2 | 2 | I/O | Clock synchronous among multiple devices. If not used, this pin can connect to ground to save power. |
| SCL | B3 | 3 | I | I ² C serial interface clock input. |
| OUT2 | C1 | 6 | O | Current sink 2. If not used, this pin can be floating or connecting to GND. |
| OUT3 | C2 | 5 | O | Current sink 3. If not used, this pin can be floating or connecting to GND. |
| SDA | C3 | 4 | I/O | I ² C serial interface data input/output. |

(1) G: Ground Pin; P: Power Pin; I: Input Pin; I/O: Input/Output Pin; O: Output Pin.

6 Specifications

6.1 Absolute Maximum Ratings

over operating free-air temperature range (unless otherwise noted)⁽¹⁾

| | | MIN | MAX | UNIT |
|----------------------------|------------------------|------|-----|------|
| Voltage range at terminals | VIN | -0.3 | 6 | V |
| | SW spike at 10 ns | -0.7 | 8 | V |
| | SW spike at 1 ns | -0.7 | 9 | V |
| | OUT0, OUT1, OUT2, OUT3 | -0.3 | 6 | V |
| | EN, SCL, SDA, SYNC | -0.3 | 6 | V |
| T _J | Junction temperature | -40 | 150 | °C |
| T _{stg} | Storage temperature | -65 | 150 | °C |

- (1) Operation outside the Absolute Maximum Ratings may cause permanent device damage. Absolute Maximum Ratings do not imply functional operation of the device at these or any other conditions beyond those listed under Recommended Operating Conditions. If used outside the Recommended Operating Conditions but within the Absolute Maximum Ratings, the device may not be fully functional, and this may affect device reliability, functionality, performance, and shorten the device lifetime.

6.2 ESD Ratings

| | | | VALUE | UNIT |
|--------------------|-------------------------|----------------------------------------------------------------------------------|-------|------|
| V _(ESD) | Electrostatic discharge | Human body model (HBM), per ANSI/ESDA/ JEDEC JS-001, all pins ⁽¹⁾ | ±4000 | V |
| | | Charged device model (CDM), per ANSI/ESDA/ JEDEC JS-002, all pins ⁽²⁾ | ±1000 | |

- (1) JEDEC document JEP155 states that 500-V HBM allows safe manufacturing with a standard ESD control process.
 (2) JEDEC document JEP157 states that 250-V CDM allows safe manufacturing with a standard ESD control process.

6.3 Recommended Operating Conditions

over operating free-air temperature range (unless otherwise noted)

| | | MIN | NOM | MAX | UNIT |
|------------------------|----------------------------------------|-----|-----|-----|--------------|
| V_{IN} | Input voltage range | 0.5 | | 5.5 | V |
| C_{IN} | Effective input capacitance range | 1 | 4.7 | | μ F |
| OUT0, OUT1, OUT2, OUT3 | Voltage on OUT0, OUT1, OUT2, OUT3 pins | 0 | | 5.5 | V |
| EN, SCL, SDA, SYNC | Voltage on EN, SCL, SDA, SYNC pins | 0 | | 5.5 | V |
| T_A | Ambient temperature | -40 | | 85 | $^{\circ}$ C |
| T_J | Operating junction temperature | -40 | | 125 | $^{\circ}$ C |

6.4 Thermal Information

| THERMAL METRIC ⁽¹⁾ | | LP5812/0 | | UNIT |
|-------------------------------|----------------------------------------------|-------------|------------|----------------|
| | | YBH (DSBGA) | DRR (WSON) | |
| | | 9 PINS | 8 PINS | |
| $R_{\theta JA}$ | Junction-to-ambient thermal resistance | 113.1 | 50.8 | $^{\circ}$ C/W |
| $R_{\theta JC(top)}$ | Junction-to-case (top) thermal resistance | 0.6 | 51.1 | $^{\circ}$ C/W |
| $R_{\theta JB}$ | Junction-to-board thermal resistance | 33.9 | 22.9 | $^{\circ}$ C/W |
| Ψ_{JT} | Junction-to-top characterization parameter | 0.2 | 1.1 | $^{\circ}$ C/W |
| Ψ_{JB} | Junction-to-board characterization parameter | 33.8 | 22.8 | $^{\circ}$ C/W |
| $R_{\theta JC(bot)}$ | Junction-to-case (bottom) thermal resistance | n/a | 8.5 | $^{\circ}$ C/W |

- (1) For more information about traditional and new thermal metrics, see the [Semiconductor and IC Package Thermal Metrics](#) application report.

6.5 Electrical Characteristics

Unless specified otherwise, typical characteristics apply over the full ambient temperature range ($-40^{\circ}\text{C} < T_A < +85^{\circ}\text{C}$), $V_{IN} = 3.6\text{ V}$, $V_{CC} = 5\text{ V}$, $C_{IN} = 1\ \mu\text{F}$, $C_{OUT} = 1\ \mu\text{F}$.

| PARAMETER | | TEST CONDITIONS | MIN | TYP | MAX | UNIT |
|-------------------------------------|--------------------------------------------------------------|--------------------------------------------------------------------------------------------------------------------------------------------------------------------------------------------------------|-----|------|------|---------------|
| Power Supply | | | | | | |
| V_{IN} | Input voltage range | | 0.5 | | 5.5 | V |
| V_{IN_UVLO} | Under-voltage lockout threshold | V_{IN} rising | | 1.7 | 1.8 | V |
| | | V_{IN} falling | | 0.4 | 0.5 | V |
| I_{SD} | Shutdown current into V_{IN} and SW pin (LP5811/3) | IC disabled (EN = Low), $V_{IN} = 3.6\text{ V}$, $T_A = 25^{\circ}\text{C}$ | | 0.1 | 0.35 | μA |
| I_{STB} | Standby current into VCC pin (LP5810/2) | CHIP_EN = 0 (bit), $V_{CC} = 3.6\text{ V}$ | | 25 | 28 | μA |
| | Standby current into V_{IN} and SW pin (LP5811/3) | CHIP_EN = 0 (bit), Boost enabled (EN = High), $V_{IN} = 3.6\text{ V}$, VOUT set to 3 V, Pass-through mode | | 26 | 29 | μA |
| | Standby current into VOUT pin (LP5811/3) | CHIP_EN = 0 (bit), Boost disabled (EN = Low), V_{IN} no supply, VOUT force to 5 V | | 25 | 28 | μA |
| I_{NOR} | Normal operation current into V_{IN} and SW pin (LP5811/3) | CHIP_EN = 1 (bit), Boost enabled (EN = High), $V_{IN} = 3.6\text{ V}$, VOUT set to 3 V, Pass-through mode, $I_{OUT0} = I_{OUT1} = I_{OUT2} = I_{OUT3} = 25.5\text{ mA}$ (MC = 0, DC = 255, PWM = 255) | | 0.45 | 0.65 | mA |
| | Normal operation current into VOUT pin (LP5811/3) | CHIP_EN = 1 (bit), Boost disabled (EN = Low), VOUT force to 3.6 V, $I_{OUT0} = I_{OUT1} = I_{OUT2} = I_{OUT3} = 25.5\text{ mA}$ (MC = 0, DC = 255, PWM = 255) | | 0.4 | 0.6 | mA |
| | Normal operation current into VCC pin (LP5810/2) | CHIP_EN = 1 (bit), $V_{CC} = 5\text{ V}$, $I_{OUT0} = I_{OUT1} = I_{OUT2} = I_{OUT3} = 25.5\text{ mA}$ (MC = 0, DC = 255, PWM = 255) | | 0.4 | 0.6 | mA |
| Boost Output(LP5811/3) | | | | | | |
| V_{OUT} | Output voltage setting range | | 3 | | 5.5 | V |
| V_{OVP} | Output over-voltage protection threshold | V_{OUT} rising | 5.5 | 5.7 | 5.9 | V |
| V_{OVP_HYS} | Over-voltage protection hysteresis | | | 0.2 | | V |
| t_{SS} | Soft startup time | From active EN to VOUT regulation. $V_{IN} = 1.8\text{ V}$, $C_{OUT} = 22\ \mu\text{F}$, $I_{VOUT} = 0\text{ mA}$ | | 450 | | μs |
| Boost Power Switch(LP5811/3) | | | | | | |
| $R_{DS(on)}$ | High-side MOSFET on resistance | $V_{VOUT} = 5\text{ V}$ | | 140 | | m Ω |
| | Low-side MOSFET on resistance | $V_{VOUT} = 5\text{ V}$ | | 60 | | m Ω |
| f_{SW} | Switching frequency | $V_{IN} = 3.6\text{ V}$, V_{OUT} set to 5.0 V, PWM mode | | 1 | | MHz |
| | | $V_{IN} = 1.0\text{ V}$, V_{OUT} set to 5.0 V, PFM mode | | 0.5 | | MHz |
| I_{LIM_SW} | Valley current limit | $V_{IN} = 3.6\text{ V}$, V_{OUT} set to 5.0 V | | 1.6 | | A |
| I_{PRECHG} | Pre-charge current | $V_{IN} = 3.6\text{ V}$ | | 350 | | mA |

Unless specified otherwise, typical characteristics apply over the full ambient temperature range ($-40^{\circ}\text{C} < \text{TA} < +85^{\circ}\text{C}$), $V_{\text{IN}} = 3.6\text{ V}$, $V_{\text{CC}} = 5\text{ V}$, $C_{\text{IN}} = 1\ \mu\text{F}$, $C_{\text{OUT}} = 1\ \mu\text{F}$.

| PARAMETER | | TEST CONDITIONS | MIN | TYP | MAX | UNIT |
|--------------------------|------------------------------------------------------------------------------------------------------------------------------|----------------------------------------------------------------------------------------------------|-----|------|------|---------------|
| LED Driver Output | | | | | | |
| $R_{\text{DS(on)_SW}}$ | Scan line switch MOSFET on resistance | $V_{\text{VOUT}} = 3\text{ V}$ | | 1 | 1.4 | Ω |
| $R_{\text{DS(on)_SW}}$ | Scan line switch MOSFET on resistance | $V_{\text{VOUT}} = 5\text{ V}$ | | 0.7 | 1.1 | Ω |
| I_{CS} | Constant current sink output range | $V_{\text{IN}} = 3.6\text{ V}$, V_{OUT} set to 5 V, MC = 0, manual_pwm_x = FFh (100% ON) | 0.1 | | 25.5 | mA |
| | | $V_{\text{IN}} = 3.6\text{ V}$, V_{OUT} set to 5 V, MC = 1, manual_pwm_x = FFh (100% ON) | 0.2 | | 51 | mA |
| $I_{\text{CS_LKG}}$ | Constant current sink leakage current | $V_{\text{IN}} = 3.6\text{ V}$, $\text{OUTx} = 1\text{ V}$, manual_pwm_x = 0 (0%) | | 0.1 | 1 | μA |
| $I_{\text{ERR_D2D}}$ | Device to device current error, $I_{\text{ERR_D2D}} = (I_{\text{AVE}} - I_{\text{SET}}) / I_{\text{SET}} \times 100\%$ | All LEDs turn ON. Current set to 0.1 mA (max_current = 0, manual_dc_x = 01h, manual_pwm_x = FFh) | -5 | | 5 | % |
| | | All LEDs turn ON. Current set to 0.2 mA (max_current = 1, manual_dc_x = 01h, manual_pwm_x = FFh) | -3 | | 3 | % |
| $I_{\text{ERR_D2D}}$ | Device to device current error, $I_{\text{ERR_D2D}} = (I_{\text{AVE}} - I_{\text{SET}}) / I_{\text{SET}} \times 100\%$ | All LEDs turn ON. Current set to 1 mA (max_current = 0, manual_dc_x = 0Ah, manual_pwm_x = FFh) | -5 | | 5 | % |
| | | All LEDs turn ON. Current set to 1 mA (max_current = 1, manual_dc_x = 05h, manual_pwm_x = FFh) | -3 | | 3 | % |
| | | All LEDs turn ON. Current set to 25.5 mA (max_current = 0, manual_dc_x = FFh, manual_pwm_x = FFh) | -5 | | 5 | % |
| | | All LEDs turn ON. Current set to 51 mA (max_current = 1, manual_dc_x = FFh, manual_pwm_x = FFh) | -3 | | 3 | % |
| $I_{\text{ERR_C2C}}$ | Channel to Channel current error $I_{\text{ERR_C2C}} = (I_{\text{OUTX}} - I_{\text{AVE}}) / I_{\text{AVE}} \times 100\%$ | All LEDs turn ON. Current set to 0.1 mA (max_current = 0, manual_dc_x = 01h, manual_pwm_x = FFh) | -5 | | 5 | % |
| | | All LEDs turn ON. Current set to 0.2 mA (max_current = 1, manual_dc_x = 01h, manual_pwm_x = FFh) | -3 | | 3 | % |
| $I_{\text{ERR_C2C}}$ | Channel to Channel current error $I_{\text{ERR_C2C}} = (I_{\text{OUTX}} - I_{\text{AVE}}) / I_{\text{AVE}} \times 100\%$ | All LEDs turn ON. Current set to 1 mA (max_current = 0, manual_dc_x = 0Ah, manual_pwm_x = FFh) | -5 | | 5 | % |
| | | All LEDs turn ON. Current set to 1 mA (max_current = 1, manual_dc_x = 05h, manual_pwm_x = FFh) | -3 | | 3 | % |
| | | All LEDs turn ON. Current set to 25.5 mA (max_current = 0, manual_dc_x = FFh, manual_pwm_x = FFh) | -5 | | 5 | % |
| | | All LEDs turn ON. Current set to 51 mA (max_current = 1, manual_dc_x = FFh, manual_pwm_x = FFh) | -3 | | 3 | % |
| V_{HR} | LED driver output hearroom voltage | All LEDs turn ON. Current set to 25.5 mA (max_current = 0, manual_dc_x = FFh) | | 0.11 | 0.15 | V |
| | | All LEDs turn ON. Current set to 51 mA (max_current = 1, manual_dc_x = FFh) | | 0.21 | 0.28 | V |
| $f_{\text{LED_PWM}}$ | LED PWM frequency | pwm_fre = 0 | | 24 | | kHz |
| | | pwm_fre = 1 | | 12 | | kHz |
| f_{OSC} | Internal oscillator frequency | vsync_out_en = 1 | | 6 | | MHz |

Unless specified otherwise, typical characteristics apply over the full ambient temperature range ($-40^{\circ}\text{C} < \text{TA} < +85^{\circ}\text{C}$), $V_{\text{IN}} = 3.6\text{ V}$, $V_{\text{CC}} = 5\text{ V}$, $C_{\text{IN}} = 1\ \mu\text{F}$, $C_{\text{OUT}} = 1\ \mu\text{F}$.

| PARAMETER | | TEST CONDITIONS | MIN | TYP | MAX | UNIT |
|------------------------|-----------------------------------------------------|-------------------------------------------------------------|------------------------------|------------------------------|------------------------------|--------------------|
| Logic Interface | | | | | | |
| $V_{\text{EN_H}}$ | EN logic high | $V_{\text{IN}} > 1.8\text{ V}$ | 1.2 | | | V |
| $V_{\text{EN_L}}$ | EN logic low | $V_{\text{IN}} > 1.8\text{ V}$ | 0.35 | | | V |
| $V_{\text{IH_LOGIC}}$ | High level input voltage of SDA, SCL, SYNC | | 1.4 | | | V |
| $V_{\text{IL_LOGIC}}$ | Low level input voltage of SDA, SCL, SYNC | | 0.4 | | | V |
| $V_{\text{OH_LOGIC}}$ | High level output voltage of SYNC | | $V_{\text{VOUT}} - 0.2$ | | | V |
| $V_{\text{OL_LOGIC}}$ | Low level output voltage of SDA, SYNC | | 0.4 | | | V |
| Protection | | | | | | |
| T_{SD} | Thermal shutdown threshold for LED driver part | T_{J} rising | 150 | | | $^{\circ}\text{C}$ |
| T_{SD} | Thermal shutdown threshold for Boost converter part | T_{J} rising | 155 | | | $^{\circ}\text{C}$ |
| $T_{\text{SD_HYS}}$ | Thermal shutdown hysteresis | T_{J} falling below T_{SD} | 15 | | | $^{\circ}\text{C}$ |
| $V_{\text{LOD_TH}}$ | LED open detection threshold | Current set to 25.5 mA (max_current = 0, manual_dc_x = FFh) | 70 | 90 | 110 | mV |
| $V_{\text{LOD_TH}}$ | LED open detection threshold | Current set to 51 mA (max_current = 1, manual_dc_x = FFh) | 150 | 180 | 220 | mV |
| $V_{\text{LSD_TH}}$ | LED short detection threshold | lsd_th = 00h | $0.32 \times V_{\text{OUT}}$ | $0.35 \times V_{\text{OUT}}$ | $0.38 \times V_{\text{OUT}}$ | V |
| | | lsd_th = 01h | $0.42 \times V_{\text{OUT}}$ | $0.45 \times V_{\text{OUT}}$ | $0.48 \times V_{\text{OUT}}$ | V |
| | | lsd_th = 10h | $0.52 \times V_{\text{OUT}}$ | $0.55 \times V_{\text{OUT}}$ | $0.58 \times V_{\text{OUT}}$ | V |
| | | lsd_th = 11h | $0.62 \times V_{\text{OUT}}$ | $0.65 \times V_{\text{OUT}}$ | $0.68 \times V_{\text{OUT}}$ | V |

6.6 Timing Requirements

Unless specified otherwise, typical characteristics apply over the full ambient temperature range ($-40^{\circ}\text{C} < T_A < +85^{\circ}\text{C}$), $V_{IN} = 3.6\text{ V}$, $V_{CC} = 5\text{ V}$, $C_{IN} = 1\ \mu\text{F}$, $C_{OUT} = 1\ \mu\text{F}$.

| I ² C Timing Requirements | | MIN | NOM | MAX | UNIT |
|--------------------------------------|----------------------------------------------------------------------------------------------|------|-----|------|------|
| Standard-mode | | | | | |
| f _{SCL} | SCL clock frequency | 0 | | 100 | kHz |
| t _{HD_STA} | Hold time (repeated) START condition. After this period, the first clock pulse is generated. | 4 | | | μs |
| t _{LOW} | LOW period of the SCL clock | 4.7 | | | μs |
| t _{HIGH} | HIGH period of the SCL clock | 4 | | | μs |
| t _{SU_STA} | Set-up time for a repeated START condition | 4.7 | | | μs |
| t _{HD_DAT} | Data hold time | 0 | | | μs |
| t _{SU_DAT} | Data set-up time | 250 | | | ns |
| t _r | Rise time of both SDA and SCL signals | | | 1000 | ns |
| t _f | Fall time of both SDA and SCL signals | | | 300 | ns |
| t _{SU_STO} | Set-up time for STOP condition | 4 | | | μs |
| t _{BUF} | Bus free time between a STOP and START condition | 4.7 | | | μs |
| C _b | Capacitive load for each bus line | | | 400 | pF |
| Fast-mode | | | | | |
| f _{SCL} | SCL clock frequency | 0 | | 400 | kHz |
| t _{HD_STA} | Hold time (repeated) START condition. After this period, the first clock pulse is generated. | 0.6 | | | μs |
| t _{LOW} | LOW period of the SCL clock | 1.3 | | | μs |
| t _{HIGH} | HIGH period of the SCL clock | 0.6 | | | μs |
| t _{SU_STA} | Set-up time for a repeated START condition | 0.6 | | | μs |
| t _{HD_DAT} | Data hold time | 0 | | | μs |
| t _{SU_DAT} | Data set-up time | 100 | | | ns |
| t _r | Rise time of both SDA and SCL signals | | | 300 | ns |
| t _f | Fall time of both SDA and SCL signals | | | 300 | ns |
| t _{SU_STO} | Set-up time for STOP condition | 0.6 | | | μs |
| t _{BUF} | Bus free time between a STOP and START condition | 1.3 | | | μs |
| C _b | Capacitive load for each bus line | | | 400 | pF |
| Fast-mode Plus | | | | | |
| f _{SCL} | SCL clock frequency | 0 | | 1000 | kHz |
| t _{HD_STA} | Hold time (repeated) START condition. After this period, the first clock pulse is generated. | 0.26 | | | μs |
| t _{LOW} | LOW period of the SCL clock | 0.5 | | | μs |
| t _{HIGH} | HIGH period of the SCL clock | 0.26 | | | μs |
| t _{SU_STA} | Set-up time for a repeated START condition | 0.26 | | | μs |
| t _{HD_DAT} | Data hold time | 0 | | | μs |
| t _{SU_DAT} | Data set-up time | 50 | | | ns |
| t _r | Rise time of both SDA and SCL signals | | | 120 | ns |
| t _f | Fall time of both SDA and SCL signals | | | 120 | ns |
| t _{SU_STO} | Set-up time for STOP condition | 0.26 | | | μs |
| t _{BUF} | Bus free time between a STOP and START condition | 0.5 | | | μs |
| C _b | Capacitive load for each bus line | | | 550 | pF |
| Misc. Timing Requirements | | | | | |

Unless specified otherwise, typical characteristics apply over the full ambient temperature range ($-40^{\circ}\text{C} < T_A < +85^{\circ}\text{C}$), $V_{IN} = 3.6\text{ V}$, $V_{CC} = 5\text{ V}$, $C_{IN} = 1\ \mu\text{F}$, $C_{OUT} = 1\ \mu\text{F}$.

| I ² C Timing Requirements | | MIN | NOM | MAX | UNIT |
|--------------------------------------|-----------------------------|-----|-----|-----|------|
| f _{CLK_EX} | VSYNC input clock frequency | | 6 | | MHz |

7 Typical Characteristics

Unless specified otherwise, typical characteristics apply over the full ambient temperature range ($-40^{\circ}\text{C} < T_A < +85^{\circ}\text{C}$), $V_{IN} = 3.6\text{ V}$, $C_{IN} = 1\ \mu\text{F}$

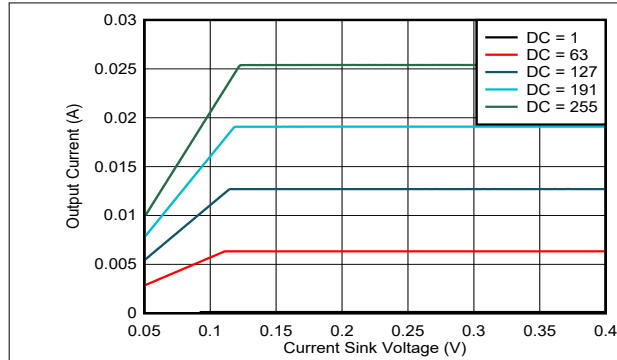

Figure 7-1. Current Sinks Voltage vs Current(MC=0)

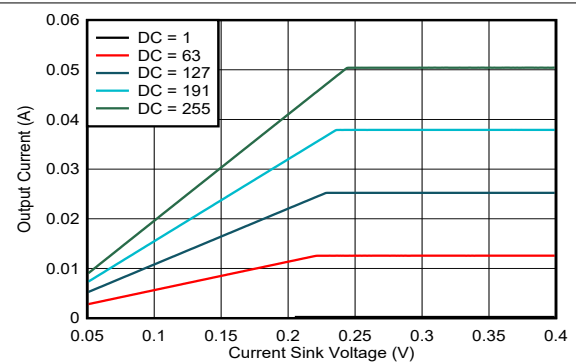

Figure 7-2. Current Sinks Voltage vs Current(MC=1)

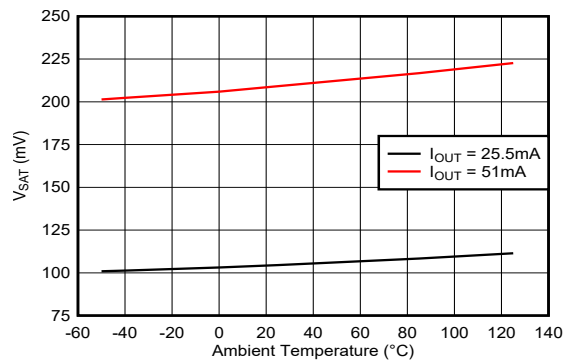

Figure 7-3. V_{SAT} vs Temperature

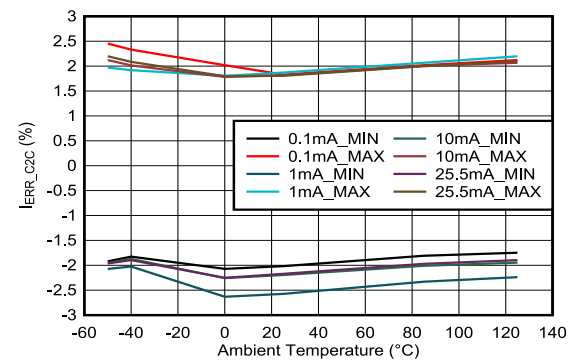

Figure 7-4. Channel-to-Channel Current Accuracy vs Temperature(MC=0)

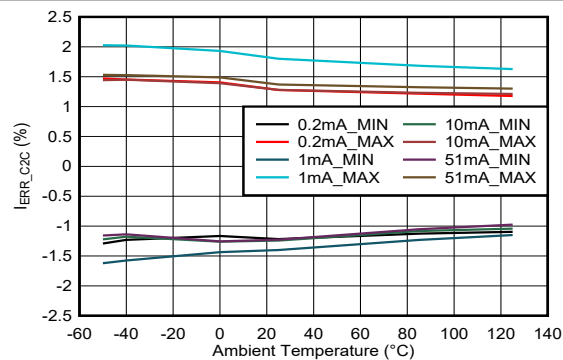

Figure 7-5. Channel-to-Channel Current Accuracy vs Temperature(MC=1)

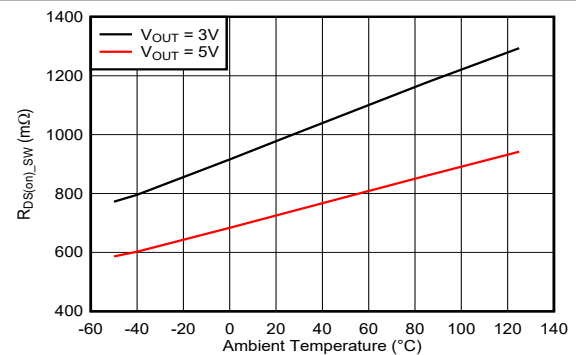

Figure 7-6. Scan Line Switch MOSFET R_{DS(on)}

8 Detailed Description

8.1 Overview

The LP5810 is a 4-channel RGBW LED driver with autonomous animation engine control.

The LP5810 has ultra-low operation current at active mode, consuming about 0.4 mA when LED maximum current setting is 25.5 mA. If all LEDs are turned off, the device will enter standby state to reduce power consumption with data retained. When 'chip_enable' bit setting is 0, initial state is entered with minimum power consumption to save power.

The LP5810 supports both analog dimming and PWM dimming. In analog dimming, the output current of each LED can be adjusted with 256 steps. In PWM dimming, the integrated 8-bit configurable PWM generator enables smooth brightness dimming control. Optional exponential PWM dimming can be activated for individual LED to achieve a human-eye-friendly visual performance.

The LP5810 integrates autonomous animation engine, with no need for brightness control commands from controller. Each LED has an individual animation engine which can be configured through the related registers. The device can generate a 6 MHz clock signal, which synchronizes the lighting effects among multiple devices.

The LP5810 has 4 different material versions with different I²C chip address. Up to 4 LP581x devices can be connected to the same I²C bus and controlled individually. The LP5810 materials and corresponding chip addresses are shown in [Section 4](#).

8.2 Functional Block Diagram

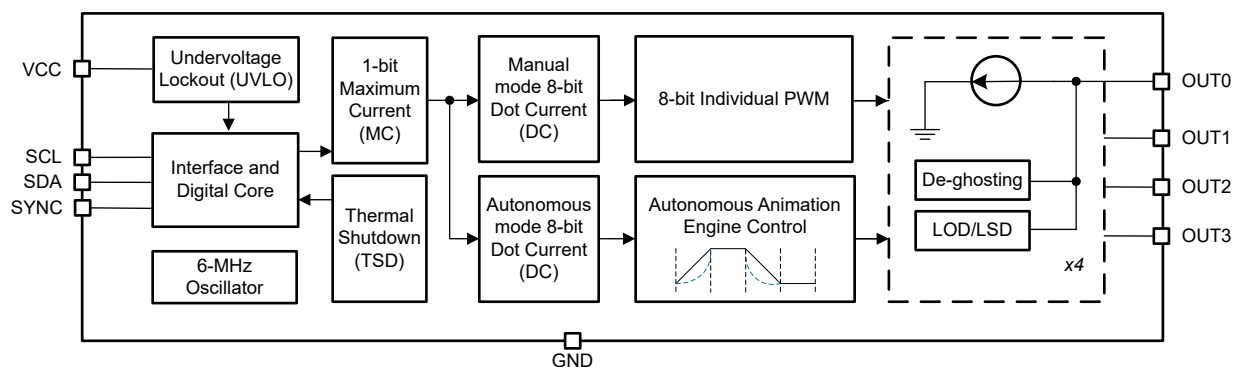

Figure 8-1. Functional Block Diagram

8.3 Feature Description

8.3.1 Analog Dimming

The current gain of each LED can be controlled by 2 methods to achieve analog dimming in the LP5810.

- Global 1-bit Maximum Current (MC) control for all LEDs without external resistor
- Individual 8-bit Dot Current (DC) control for each LED

The maximum output current I_{OUT_max} of each current sink can be programmed by the 1-bit max_current. The default value of max_current is 0h, which means the LED maximum current is set to 25.5 mA in default.

Table 8-1. Maximum Current (MC) bit setting

| 1 bit Maximum Current (MC) | | I_{OUT_MAX} (mA) |
|----------------------------|-------------|---------------------|
| Binary | Decimal | |
| 0 (default) | 0 (default) | 25.5 (default) |
| 1 | 1 | 51 |

The LP5810 can individually adjust the peak current of each LED by using Dot Current (DC) function. The brightness deviation among the LED bins can be minimized, to achieve uniform display performance. The

current is adjusted with 256 steps from 0 to 100% of I_{OUT_MAX} , which is programmed in an 8-bit register whose default value is 80h.

Table 8-2. Dot Current (DC) bits setting

| 8-bits Dot Current (DC) Register | | Ratio of I_{OUT_MAX} |
|----------------------------------|---------------|-------------------------|
| Binary | Decimal | |
| 0000 0000 | 0 | 0% |
| 0000 0001 | 1 | 0.39% |
| 0000 0010 | 2 | 0.78% |
| --- | --- | --- |
| 1000 0000 (default) | 128 (default) | 50.2% (default) |
| --- | --- | --- |
| 1111 1101 | 253 | 99.2% |
| 1111 1110 | 254 | 99.6% |
| 1111 1111 | 255 | 100% |

By configuring the MC and DC, the peak current of each current sink can be calculated as [Equation 1](#):

$$I_{OUT} (mA) = I_{OUT_max} \times \frac{DC}{255} \quad (1)$$

The average current of each LED in TCM drive mode and mix drive mode is shown as [Equation 2](#):

$$I_{AVE} (mA) = \frac{I_{OUT}}{N} \times \frac{DC}{255} \times D_{PWM} \quad (2)$$

- N is the total scan number setting.
- D_{PWM} is the PWM duty.

8.3.2 PWM Dimming

The LP5810 supports 8-bit PWM dimming with 24 kHz or 12 kHz frequency, which is configured by 'PWM_Fre' bit in Dev_config_1 register. An internal 6 MHz oscillator is used to generate the PWM clock. SYNC pin can be configured as PWM clock input or output by configure 'vsync_out_en' bit in Dev_Config_11 register. If multiple LP5810 are used in the system with autonomous animation engine control, all devices can refer the same clock signal, which comes from one of LP5810 or external controller, to avoid animation mismatch in long time operation.

Each LED can be configured into 3 different PWM alignment phases: Forward, Middle, and Backward. The alignment phase of each LED is set by 'phase_align' bits in Dev_Config_7 to Dev_Config_10 registers. By turning on the LEDs in different phase, the peak current load from boost or the system power supply is greatly decreased. The input current ripple and ceramic-capacitor audible ringing can also be reduced. [Figure 8-2](#) shows the PWM alignment phases. In the forward alignment, the rising edge of PWM pulse is fixed at the beginning of PWM period. In the middle alignment, the middle point of PWM pulse is fixed at the middle of PWM period, while the pulse spreads to both directions. In the backward alignment, the falling edge of PWM pulse is fixed at the end of PWM period.

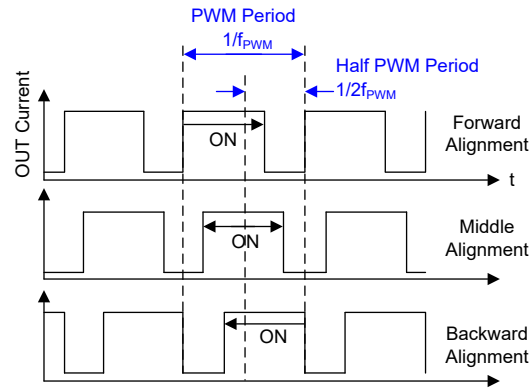

Figure 8-2. PWM Alignment Scheme

The LP5810 allow users to configure the dimming scale as exponential curve or linear curve, through the 'exp_en' bits in Dev_Config_5 and Dev_Config_6 registers. A human-eye-friendly visual performance can be achieved by using the internal exponential scale. The linear scale has great linearity between PWM duty cycle and PWM setting value, which provides flexible approach for external controlled gamma correction algorithm. The 8-bit linear and exponential curves are shown as Figure 8-3.

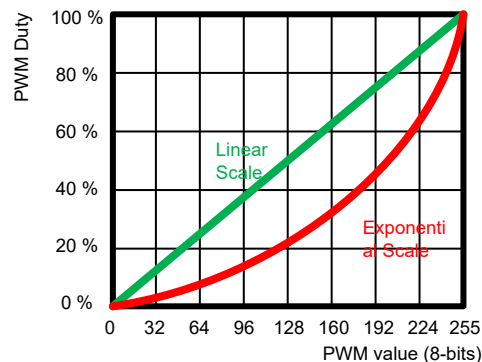

Figure 8-3. Linear and Exponential PWM Dimming Curves

8.3.3 Autonomous Animation Engine Control

The LP5810 supports both manual mode and autonomous mode to control the DC and PWM of each LED. In manual mode, the LEDs are directly controlled by the related configuration registers and reflect the value immediately. In autonomous mode, the autonomous animation engine is applied for each LED, which can realize vivid lighting effects without external processor control. The animation engine pattern is composed by 3 animation engine units (AEU) and 2 animation pause units (APU) for complex and flexible control. One AEU is formed by 4 slopers, which is used for fading effect.

After setting up all animation engine pattern configurations, sending start_cmd to the device can let the animation running autonomously, to free external controller real-time loading. The PWM value and unit status of each LED can be read from PWM_value registers and pattern_status registers. To make sure the precision of reading results, sending pause_cmd to pause the animation firstly is recommended.

8.3.3.1 Animation Engine Pattern

Each LED of the LP5810 has own animation engine, to achieve premium visual lighting effects. One whole animation engine pattern is defined as Figure 8-4. 3 animation engine units (AEU) and 2 animation pause units (APU) compose the animation engine pattern. AEU2 and AEU3 can be skipped by setting the playback times to 0. The LED current of each LEDs in the autonomous mode is set through the Autonomous_DC registers.

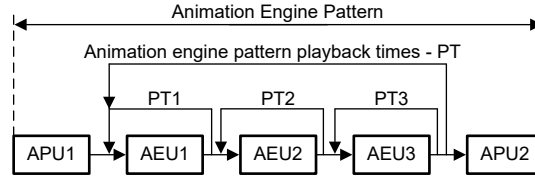

Figure 8-4. Animation engine pattern

The whole animation pattern includes two APUs and three AEUs with several playback times:

- APU_x (x = 1, 2): Animation pause unit, each unit includes one timing value T.
- AEU_x (x = 1, 2, 3): Animation engine unit, including 5 PWM values PWM1 to PWM5 and 4 time values T1 to T4.
- PT: Playback times of AEU1+AEU2+AEU3, which has 2-bit value to set 0/1/2/Infinite times.
- PT_x: Playback times of AEU_x (x=1/2/3), which has 2-bit value to set 0/1/2/Infinite times.

8.3.3.2 Sloper

Sloper is the basic element to achieve autonomous fade-in and fade-out animations. It can achieve 256 steps fade-in or fade-out effects from 'PWM_Start' to 'PWM_End' within a target time period T as Figure 8-5. The 8-bit PWM steps, which is configurable in animation pattern PWM setting registers, help to achieve extremely smooth effects. Exponential dimming curve can also be supported in the sloper.

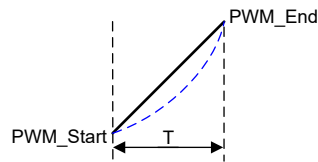

Figure 8-5. Sloper curve demonstration

The programmable time T is selectable from 0 to around 8 s with 16 levels shown in Table 8-3.

Table 8-3. Programmable time options

| Register value | 0h | 1h | 2h | 3h | 4h | 5h | 6h | 7h | 8h | 9h | Ah | Bh | Ch | Dh | Eh | Fh |
|----------------|-----|--------|--------|--------|--------|--------|--------|--------|--------|--------|--------|--------|--------|--------|--------|--------|
| Time (Typ.) | 0 s | 0.09 s | 0.18 s | 0.36 s | 0.54 s | 0.80 s | 1.07 s | 1.52 s | 2.06 s | 2.50 s | 3.04 s | 4.02 s | 5.01 s | 5.99 s | 7.06 s | 8.05 s |

8.3.3.3 Animation Engine Unit (AEU)

The AEU is the most important unit to achieve autonomous animation effects. One AEU is formed by 4 slopers. There are 5 PWM values and 4 time values can be configured in the AEU. Each PWM_x (x = 1, 2, ..., 5) can be arbitrarily programmed from 0 to 255, The T_x (x = 1, 2, 3, 4) is selectable from 0 to 8 s with 16 levels referring to Table 8-3. If two adjacent PWM values are equal, the brightness keeps unchange within the time setting. When a T_x is set to 0, this sloper is skipped. To avoid flicker happens due to PWM value suddenly changes, the begin and end PWM of this sloper need to be the same.

Typical breathing effect example is illustrated as Figure 8-6.

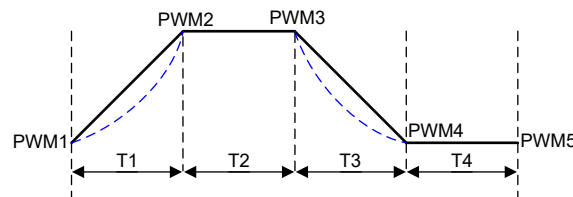

Figure 8-6. Animation engine unit - Example 1

Advanced breathing effect example is shown in Figure 8-7. 2 different fading speeds are set in the PWM rising and falling phases, to achieve a complex animation.

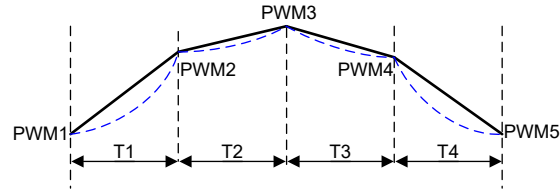

Figure 8-7. Animation engine unit - Example 2

8.3.3.4 Animation Pause Unit (APU)

The APU is defined as the pausing time at the beginning and the end of the animation pattern. The APU contains 1 time value which is selectable from 0 to 8 s with 16 levels referring to [Table 8-3](#). If the value is set as 0, the APU is skipped. The brightness of APU1 uses the PWM1 value of the AEU following the APU1, while the brightness of APU2 uses the PWM5 value of the AEU in front of APU2. One animation pattern example is shown in [Figure 8-8](#). Only AEU2 is enabled in the pattern, so that the brightness of APU1 uses the PWM1 value of AEU2, and the brightness of APU2 uses PWM5 value of AEU2.

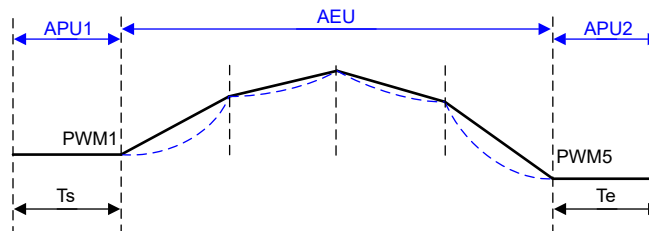

Figure 8-8. APU example

8.3.4 Protections and Diagnostics

8.3.4.1 LED Open Detections

The LP5810 integrates LED open detection (LOD) for the fault caused by any open LED. The threshold for LOD is 90 mV when max current is set as 25.5 mA, and 180 mV when max current is set as 51 mA. To have enough detection time, LOD can only be performed when the PWM setting of this LED is above 25. If the voltage on the cathode of this LED is lower than the LOD threshold in continuously 3 cycles, LED open of this LED is reported to the corresponding LOD_status register.

The LOD flags can be cleared by writing 1h to 'lod_clear' bit in Fault_Clear register. If the LED open status is removed, the related 'lod_status' bit is set to 0 automatically.

The 'lod_action' bit in Dev_config_12 register can determine the action once open fault is detected. When the 'lod_action' bit is set to 1h, the dot where LED open happens is turned off to avoid any unpredictable issue. When the 'lod_action' bit is 0, no additional action is taken after LOD is detected. LED open fault detection and action is only executed in NORMAL state.

8.3.4.2 LED Short Detections

The LP5810 integrates LED short detection (LSD) for the fault caused by any short LED. The threshold of LSD is able to configure from $(0.35 \times V_{OUT})$ V to $(0.65 \times V_{OUT})$ V by configuring `lzd_threshold` in `Dev_config_12` register. To have enough detection time, LSD can only be performed when the PWM setting of this LED is above 25. If the voltage on the cathode of this LED is higher than the LSD threshold in continuously 3 cycles, LED short of this LED is reported to the corresponding `LSD_status` register.

The LSD flags can be cleared by writing 1h to `lzd_clear` in `Fault_CLR` register. If the LED short status is removed, the related `lzd_status` bit is set to 0 automatically.

The 'lzd_action' bit in `Dev_config_12` register can determine the reaction once open fault is detected. When the 'lzd_action' bit is set to 1h, all LEDs are turned off which is called one fails all fail (OFAF) action, to prevent potential damage caused by the short issue. The device enters to STANDBY state after sending 'lzd_clear' command. When the 'lzd_action' bit is 0, no additional action is taken after LSD is detected. LSD detection is only executed in NORMAL state.

8.3.4.3 Thermal Shutdown

The LED driver of LP5810 goes into thermal shutdown state once the junction temperature exceeds 150°C. All LEDs turn off to avoid damaging the device. When the junction temperature drops below the thermal shutdown recovery temperature 130°C, the LED driver starts operating again.

8.4 Device Functional Modes

The [Figure 8-9](#) shows the main state machine of the LED driver.

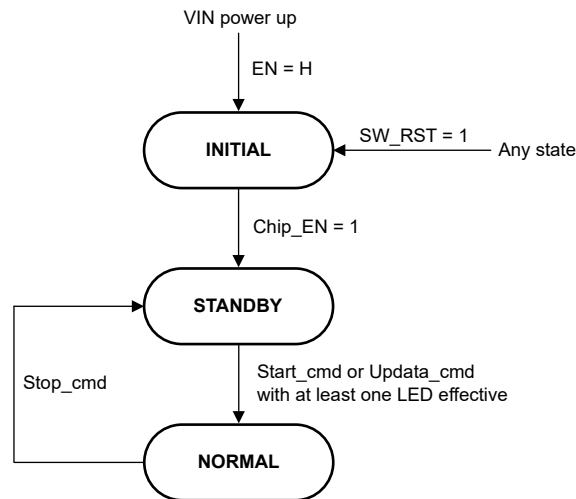

Figure 8-9. LP5810 functional modes

- INITIAL: The device enters into INITIAL after VIN power up.
- STANDBY: The device enters into STANDBY state from INITIAL when `Chip_EN` is set to 1. The device can also enter into STANDBY from NORMAL when no LED is effective, or `Stop_cmd` is received, or from OFAF when `LSD_Clear = 1`.
- NORMAL: The device enters NORMAL state from STANDBY when one or more LEDs are effective: for manual mode, at least one LED is enable (PWM and DC setting is not 0); for autonomous mode, at least one LED is enable and `Start_cmd` is received.

8.5 Programming

The LP5810 is compatible with I²C standard specification. The device supports standard mode (100-kHz maximum), fast mode (400-kHz maximum), and fast plus mode (1-MHz maximum). The device has 4 different chip address versions, which allows connecting up to four parallel devices in one I²C bus.

8.5.1 I²C Data Transactions

The data on SDA line must be stable during the HIGH period of the clock signal (SCL). In other words, state of the data line can only be changed when clock signal is LOW. START and STOP conditions classify the beginning and the end of the data transfer session. A START condition is defined as the SDA signal transitioning from HIGH to LOW while SCL line is HIGH. A STOP condition is defined as the SDA transitioning from LOW to HIGH while SCL is HIGH. The bus leader always generates START and STOP conditions. The bus is considered to be busy after a START condition and free after a STOP condition. During data transmission, the bus leader can generate repeated START conditions. First START and repeated START conditions are functionally equivalent.

Each byte of data has to be followed by an acknowledge bit. The acknowledge related clock pulse is generated by the leader. The leader releases the SDA line (HIGH) during the acknowledge clock pulse. The device pulls down the SDA line during the 9th clock pulse, signifying an acknowledge. The device generates an acknowledge after each byte has been received.

There is one exception to the acknowledge after every byte rule. When the leader is the receiver, the receiver must indicate to the transmitter an end of data by not acknowledging (*negative acknowledge*) the last byte clocked out of the follower. This negative acknowledge still includes the acknowledge clock pulse (generated by the leader), but the SDA line is not pulled down.

8.5.2 I²C Data Format

The address and data bits are transmitted MSB first with 8-bits length format in each cycle. Each transmission is started with Address Byte 1, which are divided into 5 bits of the chip address, 2 higher bits of the register address, and 1 read/write bit. The other 8 lower bits of register address are put in Address Byte 2. The device supports both independent mode and broadcast mode. The auto-increment feature allows writing / reading several consecutive registers within one transmission. If not consecutive, a new transmission must be started. The Bit 4 and Bit 3 are determined by the device, which can refer to [Section 4](#).

Table 8-4. I²C Data Format

| Address Byte1 | Chip Address | | | | | Register Address | | R/W |
|---------------|---------------------|---------------------|---------------------|---------------------|---------------------|---------------------|---------------------|-----------|
| | Bit 7 | Bit 6 | Bit 5 | Bit 4 | Bit 3 | Bit 2 | Bit 1 | Bit 0 |
| Independent | 1 | 0 | 1 | Bit 4 | Bit 3 | 9 th bit | 8 th bit | R: 1 W: 0 |
| Broadcast | 1 | 1 | 0 | 1 | 1 | | | |
| Address Byte2 | Register Address | | | | | | | |
| | Bit 7 | Bit 6 | Bit 5 | Bit 4 | Bit 3 | Bit 2 | Bit 1 | Bit 0 |
| | 7 th bit | 6 th bit | 5 th bit | 4 th bit | 3 rd bit | 2 nd bit | 1 st bit | 0 bit |

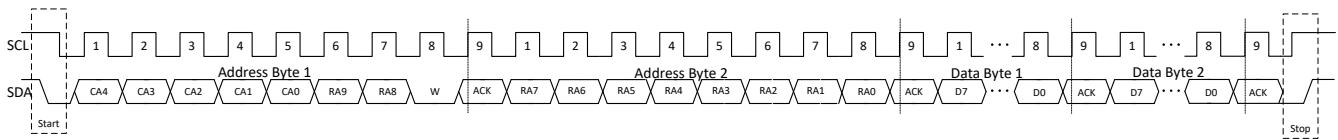

Figure 8-10. I²C Write Timing

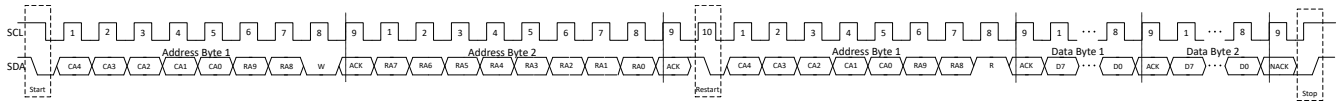

Figure 8-11. I²C Read Timing

9 Register Maps

This section provides a summary of the LP5810 register maps.

Table 9-1. Register Section/Block Access Type Codes

| Access Type | Code | Description |
|------------------------|--------------|-----------------------------------------------|
| Read Type | | |
| R | R | Read |
| RC | R C | Read to Clear |
| R-0 | R -0 | Read Returns 0s |
| Write Type | | |
| W | W | Write |
| W0CP | W 0C P | W 0 to clear Requires privileged access |
| Reset or Default Value | | |
| -n | | Value after reset or the default value |

Table 9-2. LP5810 Registers Map

| Register Group | Register Acronym | Address(Hex.) | Function | Type |
|----------------|------------------------------|---------------|-------------------------------------------------------------------------------------------------------|------|
| ChipEN | Chip_en | 000 | Chip enable | R/W |
| CONFIG | Dev_config0 ~ Dev_config12 | 001 ~ 00D | Device configuration registers | R/W |
| Update CMD | Update_cmd | 010 | Configuration update command: CONFIG registers will ONLY be effective by sending this command | R/W |
| Start CMD | Start_cmd | 011 | Autonomous control start command or restart with the latest setting | R/W |
| Stop CMD | Stop_cmd | 012 | LED driver stop command, LED driver goes to INITIAL state with this command from all the other states | R/W |
| Pause CMD | Pause_cmd | 013 | Autonomous control pause command | R/W |
| Continue CMD | Continue_cmd | 014 | Autonomous control continue command | R/W |
| LED EN | LED_EN1 ~ LED_EN2 | 020 ~ 021 | LED enable registers | R/W |
| Fault CLR | Fault_Clear | 022 | Fault clear registers to clear TSD/LOD/LSD faults | R/W |
| RESET | Reset | 023 | Software reset | W |
| DC_Manual | DC0 ~ DC_D2 | 030 ~ 03F | LED current setting at manual mode | R/W |
| PWM_Manual | PWM0 ~ PWM_D2 | 040 ~ 04F | LED PWM setting at manual mode | R/W |
| DC_Auto | DC_Auto0 ~ DC_Auto_D2 | 050 ~ 05F | LED current setting at autonomous mode | R/W |
| LED0 AEP | Tp, PT, PWM1 ~ PWM5, T1 ~ T4 | 080 ~ 099 | LED0 Animation Engine Pattern parameters | R/W |
| LED1 AEP | Tp, PT, PWM1 ~ PWM5, T1 ~ T4 | 09A ~ 0B3 | LED1 Animation Engine Pattern parameters | R/W |
| LED2 AEP | Tp, PT, PWM1 ~ PWM5, T1 ~ T4 | 0B4 ~ 0CD | LED2 Animation Engine Pattern parameters | R/W |
| LED3 AEP | Tp, PT, PWM1 ~ PWM5, T1 ~ T4 | 0CE ~ 0E7 | LED3 Animation Engine Pattern parameters | R/W |
| LED_A0 AEP | Tp, PT, PWM1 ~ PWM5, T1 ~ T4 | 0E8 ~ 101 | LED_A0 Animation Engine Pattern parameters | R/W |
| LED_A1 AEP | Tp, PT, PWM1 ~ PWM5, T1 ~ T4 | 102 ~ 11B | LED_A1 Animation Engine Pattern parameters | R/W |
| LED_A2 AEP | Tp, PT, PWM1 ~ PWM5, T1 ~ T4 | 11C ~ 135 | LED_A2 Animation Engine Pattern parameters | R/W |
| LED_B0 AEP | Tp, PT, PWM1 ~ PWM5, T1 ~ T4 | 136 ~ 14F | LED_B0 Animation Engine Pattern parameters | R/W |
| LED_B1 AEP | Tp, PT, PWM1 ~ PWM5, T1 ~ T4 | 150 ~ 169 | LED_B1 Animation Engine Pattern parameters | R/W |
| LED_B2 AEP | Tp, PT, PWM1 ~ PWM5, T1 ~ T4 | 16A ~ 183 | LED_B2 Animation Engine Pattern parameters | R/W |

Table 9-2. LP5810 Registers Map (continued)

| | | | | |
|------------|-----------------------------------|-----------|---------------------------------------------------------------------|-----|
| LED_C0 AEP | Tp, PT, PWM1 ~ PWM5, T1 ~ T4 | 184 ~ 19D | LED_C0 Animation Engine Pattern parameters | R/W |
| LED_C1 AEP | Tp, PT, PWM1 ~ PWM5, T1 ~ T4 | 19E ~ 1B7 | LED_C1 Animation Engine Pattern parameters | R/W |
| LED_C2 AEP | Tp, PT, PWM1 ~ PWM5, T1 ~ T4 | 1B8 ~ 1D1 | LED_C2 Animation Engine Pattern parameters | R/W |
| LED_D0 AEP | Tp, PT, PWM1 ~ PWM5, T1 ~ T4 | 1D2 ~ 1EB | LED_D0 Animation Engine Pattern parameters | R/W |
| LED_D1 AEP | Tp, PT, PWM1 ~ PWM5, T1 ~ T4 | 1EC ~ 205 | LED_D1 Animation Engine Pattern parameters | R/W |
| LED_D2 AEP | Tp, PT, PWM1 ~ PWM5, T1 ~ T4 | 206 ~ 21F | LED_D2 Animation Engine Pattern parameters | R/W |
| STATUS | TSD_Config_Status | 300 | TSD status and Configuration error indication register | R |
| | LOD_Status1 ~ LOD_Status2 | 301 ~ 302 | LOD status registers | R |
| | LSD_Status1 ~ LSD_Status2 | 303 ~ 304 | LSD status registers | R |
| | PWM_Internal0 ~ PWM_Internal_D2 | 305 ~ 314 | Internal PWM values for LED0 ~ LED_D2 | R |
| | PATTERN_Status1 ~ PATTERN_Status8 | 315 ~ 31C | AEP status registers to indicate pattern progress for LED0 ~ LED_D2 | R |

10 Application and Implementation

Note

Information in the following applications sections is not part of the TI component specification, and TI does not warrant its accuracy or completeness. TI's customers are responsible for determining suitability of components for their purposes, as well as validating and testing their design implementation to confirm system functionality.

10.1 Application Information

The LP5810 is a 4-ch RGB LED driver with autonomous animation engine control. The LP5810 has ultra-low operation current at active mode, and it only consumes 0.4 mA when LED current is set at 25mA. In battery powered applications like e-tag, earbud, e-cigarettes, VR headset, RGB mouse, smart speaker, and other handheld devices, LP5810 is ideal to provide premium LED lighting effects with low power consumption and small package.

10.2 Typical Application

10.2.1 Application

Figure 10-1 shows an example of typical application, which uses one LP5810 to drive RGB LEDs through I²C communication.

Figure 10-1. Typical Application - LP5810 Driving RGB LEDs

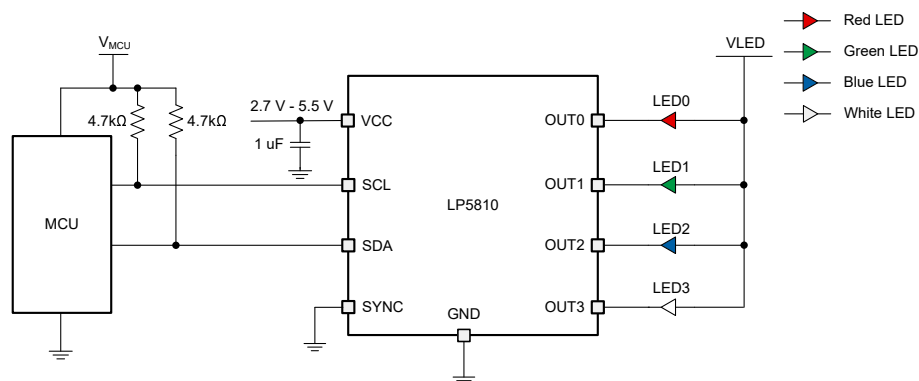

Figure 10-2. Typical Application - LP5810 Driving RGB LEDs

10.2.2 Design Parameters

Design Parameters shows the typical design parameters of [Typical Application 1](#).

Table 10-1. Design Parameters

| PARAMETER | VALUE |
|------------------------------------------------|------------------------------------------|
| Input voltage | 3.6 V to 4.2 V by one Li-on battery cell |
| RGB LED count | 4 |
| LED maximum average current (red, green, blue) | 12.75 mA, 10.2 mA, 10.2 mA |
| LED peak current (red, green, blue) | 51 mA, 40.8 mA, 40.8 mA |
| LED PWM frequency | 6 kHz |

The different color of LEDs are put as below configuration.

Red LEDs: LED_A1, LED_B1, LED_C1, LED_D1

Green LEDs: LED_A0, LED_B0, LED_C0, LED_D0

Blue LEDs: LED_A2, LED_B2, LED_C2, LED_D2

10.2.3 Detailed Design Procedure

This section will showcase the detailed design procedures for LP5810 including boost components selection, LED driver manual and autonomous modes application examples.

10.2.3.1 Input Capacitor Selection

Multilayer X5R or X7R ceramic capacitors are excellent choices for the input decoupling of the integrated boost converter, because of the extremely low ESR and small footprint. Input capacitors must be located as close as possible to the device. While a 10- μ F input capacitor is sufficient for most applications, large capacitance is used to reduce input current ripple. When the input power is supplied through long wire and only ceramic capacitor is put, the load step at the output induces ringing at the VIN pin. This ringing couples back to the output and influence loop stability or even damage the device. In this circumstance, placing additional bulk capacitance (tantalum or aluminum electrolytic capacitor) between ceramic input capacitor and the power supply can reduce the ringing

10.2.3.2 Program Procedure

After VIN powering up, the device can be initialized by configuring `chip_en = 1`. Then the CONFIG registers can be set to the expected configuration. After updating the CONFIG registers, one update command must be sent to make the configuration effective. Either manual mode or autonomous mode can be selected for each LED. A new configuration is only effective once update command is received.

The detailed program procedure is illustrated as:

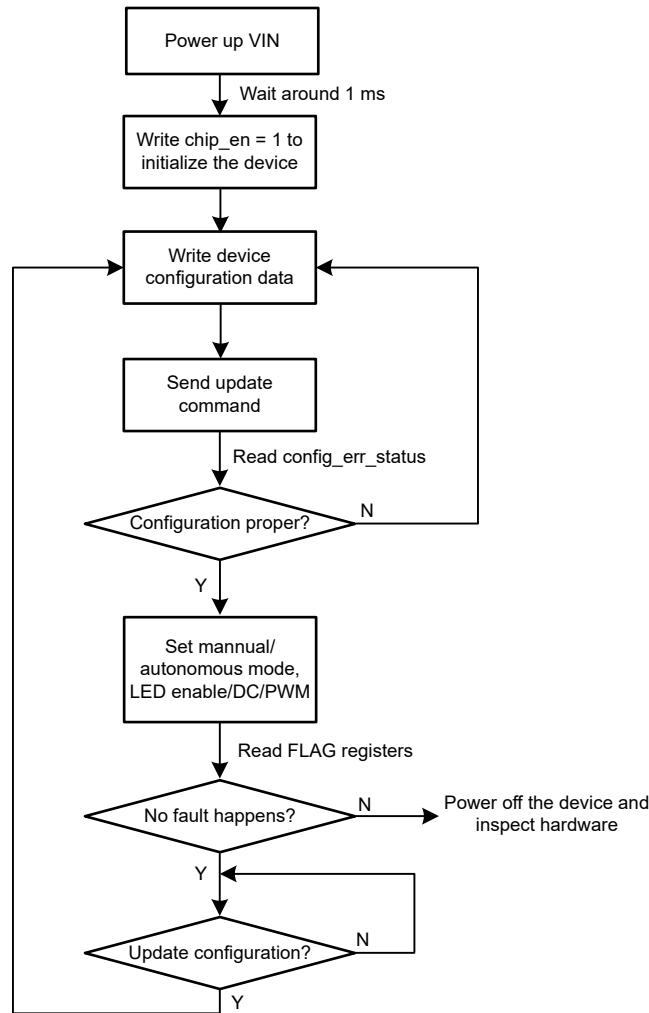

Figure 10-3. Program Procedure

10.2.3.3 Programming Example

To get the design parameters in [Section 10.2.2](#), the following program steps can be referred.

After properly providing the power supplies to LP5810,

1. Set `chip_en = 1` to enable the device. **(Write 01h to register 000h)**
2. Set `led_mode = 4h` to configure the LED drive mode as TCM 4 scans. **(Write 20h to register 002h)**
3. Set `lsd_threshold = 3h` is recommended to avoid incorrect LSD detection. **(Write 0Bh to register 00Dh)**

Let the PWM frequency, scan order, manual or autonomous mode, linear or exponential dimming curve, phase align method, vsync mode, blank time, clamp settings as default. (In other application requirements, these functions can be set)

4. Send update command to complete configuration settings **(Write 55h to register 010h)**

5. Read back config_err_status to check if the configuration is proper (**Read register 300h**)
6. Enable all 12 LEDs (**Write F0h to register 020h and FFh to register 021h**)
7. Set 50 mA peak current for red LEDs (**Write FFh to registers 035h, 038h, 03Bh, 03Eh**), and 40 mA peak current for green and blue LEDs (**Write CCh to registers 034h, 036h, 037h, 039h, 03Ah, 03Ch, 03Dh, 03Fh**)
8. Set 100% duty cycle to illuminate the LEDs (**Write FFh to registers 044h - 04Fh**)

10.2.4 Application Performance Plots

The following figures show the application performance plots.

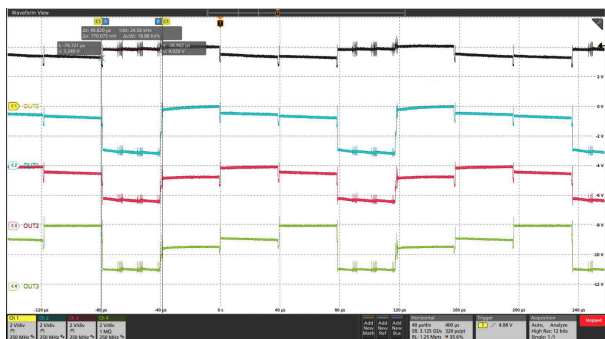

PWM frequency = 24 kHz
LED_A0/A1/A2 enable
led_mode = 4h

Figure 10-4. Scan Lines and Current Sinks Waveforms of OUT0, OUT1, OUT2, OUT3

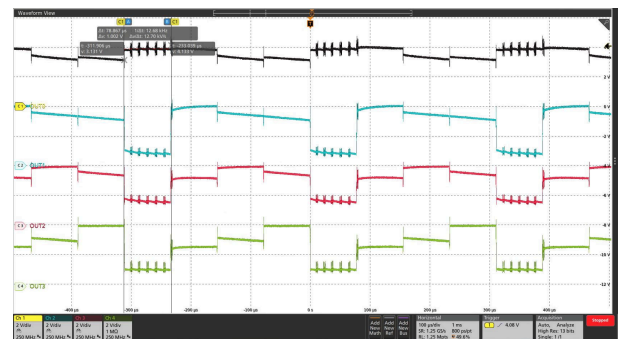

PWM frequency = 12 kHz
LED_A0/A1/A2 enable
led_mode = 4h

Figure 10-5. Scan Lines and Current Sinks Waveforms of OUT0, OUT1, OUT2, OUT3

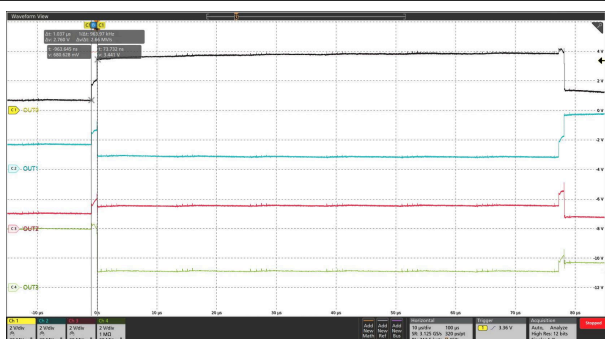

Switch blank time $t_{SW_BLK} = 1 \mu s$
Figure 10-6. Scan Lines Switching Waveforms of OUT0, OUT1, OUT2, OUT3

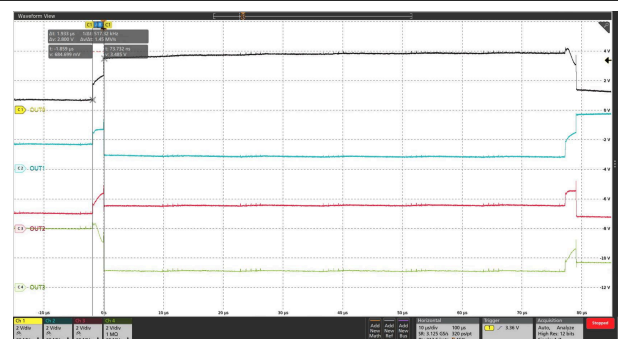

Switch blank time $t_{SW_BLK} = 2 \mu s$
Figure 10-7. Scan Lines Switching Waveforms of OUT0, OUT1, OUT2, OUT3

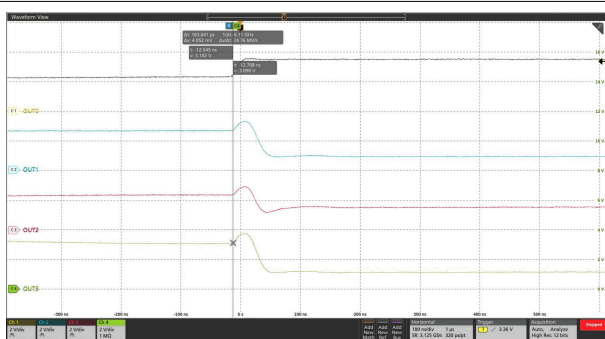

phase_align_a0 = 0h, phase_align_a1 = 0h, phase_align_a2 = 0h, PWM = 127
Figure 10-8. PWM Alignment Disabled

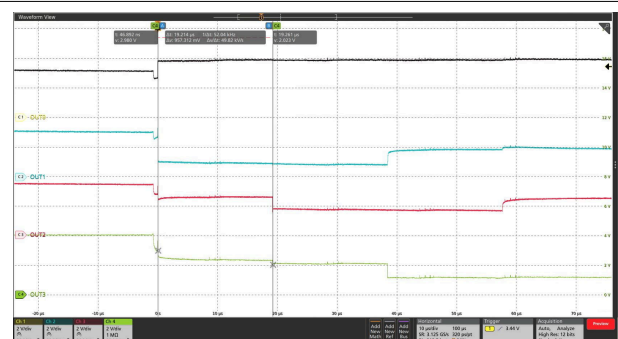

phase_align_a0 = 1h, phase_align_a1 = 2h, phase_align_a2 = 3h, PWM = 127
Figure 10-9. PWM Alignment Enabled

10.3 Power Supply Recommendations

The LP5810 can also work normally by powering from VOUT with 2.7 V to 5.5 V voltage range, to bypass the integrated boost converter. In direct drive mode or mix drive mode, an external LED supply with 2.7 V to 5.5 V voltage range is supported to power up the LEDs in direct drive configurations.

10.4 Layout

10.4.1 Layout Guidelines

As for all switching power supplies, especially those running at high switching frequency and high currents, layout is an important design step. If the layout is not carefully done, the regulator could suffer from instability and noise problems. To maximize efficiency, switch rise and fall time are very fast. To prevent radiation of high frequency noise (for example, EMI), proper layout of the high-frequency switching path is essential. Minimize the length and area of all traces connected to the SW pin, and always use a ground plane under the switching regulator to minimize interplane coupling. The input capacitor needs not only to be close to the VIN pin, but also to the GND pin in order to reduce input supply ripple. The most critical current path for all boost converters is from the switching FET, through the rectifier FET, then the output capacitors, and back to ground of the switching FET. This high current path contains nanosecond rise and fall time and must be kept as short as possible. Therefore, the output capacitor not only must be close to the VOUT pin, but also to the GND pin to reduce the overshoot at the SW pin and VOUT pin. For OUTx (x = 0, 1, 2, 3), low inductive and resistive path of switch load loop can help to provide a high slew rate. Therefore, path of adjacent outputs must be short and wide and avoid parallel wiring and narrow trace. For better thermal performance, TI suggest to make copper polygon connected with each pin bigger.

10.4.2 Layout Example

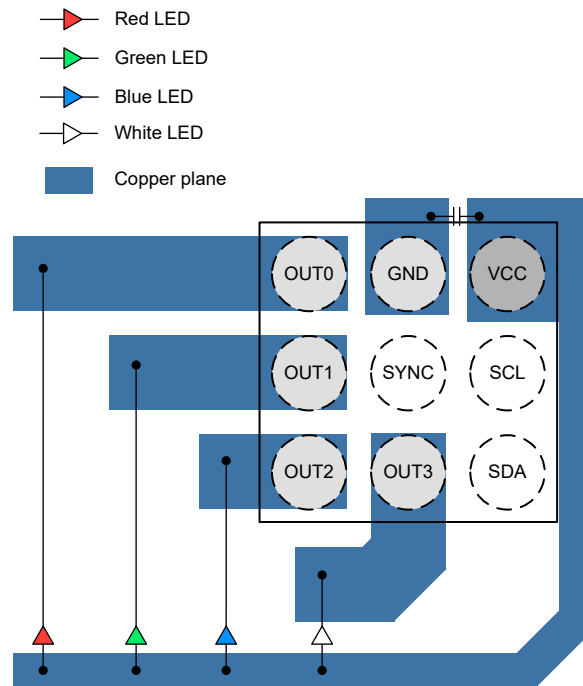

Figure 10-10. LP5810 DSBGA Package Layout Example

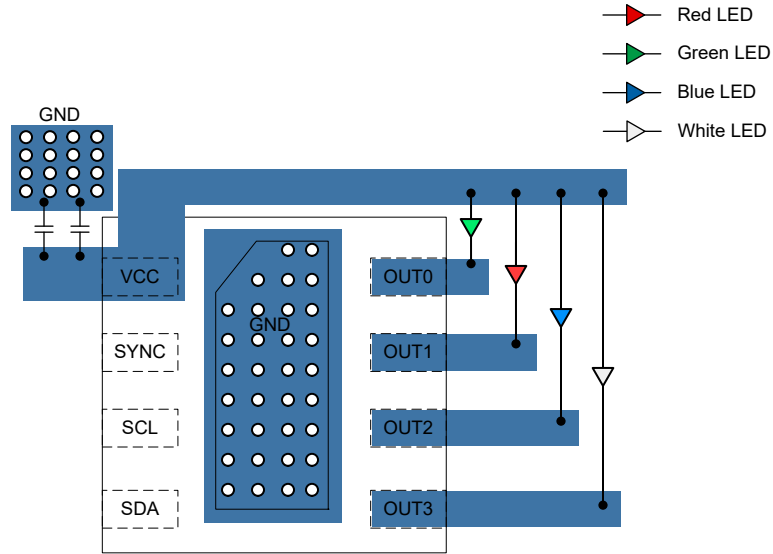

Figure 10-11. LP5810 WSON Package Layout Example

11 Device and Documentation Support

TI offers an extensive line of development tools. Tools and software to evaluate the performance of the device, generate code, and develop solutions are listed below.

11.1 Documentation Support

11.2 Receiving Notification of Documentation Updates

To receive notification of documentation updates, navigate to the device product folder on ti.com. Click on *Notifications* to register and receive a weekly digest of any product information that has changed. For change details, review the revision history included in any revised document.

11.3 Support Resources

[TI E2E™ support forums](#) are an engineer's go-to source for fast, verified answers and design help — straight from the experts. Search existing answers or ask your own question to get the quick design help you need.

Linked content is provided "AS IS" by the respective contributors. They do not constitute TI specifications and do not necessarily reflect TI's views; see TI's [Terms of Use](#).

11.4 Trademarks

TI E2E™ is a trademark of Texas Instruments.
All trademarks are the property of their respective owners.

11.5 Electrostatic Discharge Caution



This integrated circuit can be damaged by ESD. Texas Instruments recommends that all integrated circuits be handled with appropriate precautions. Failure to observe proper handling and installation procedures can cause damage.

ESD damage can range from subtle performance degradation to complete device failure. Precision integrated circuits may be more susceptible to damage because very small parametric changes could cause the device not to meet its published specifications.

11.6 Glossary

[TI Glossary](#) This glossary lists and explains terms, acronyms, and definitions.

12 Revision History

NOTE: Page numbers for previous revisions may differ from page numbers in the current version.

| Changes from Revision * (November 2023) to Revision A (November 2023) | Page |
|--------------------------------------------------------------------------------|-------------|
| • Changed document status from "Advance Information" to "Production Data"..... | 1 |

13 Mechanical, Packaging, and Orderable Information

The following pages include mechanical, packaging, and orderable information. This information is the most current data available for the designated devices. This data is subject to change without notice and revision of this document. For browser-based versions of this data sheet, refer to the left-hand navigation.

PACKAGING INFORMATION

| Orderable Device | Status (1) | Package Type | Package Drawing | Pins | Package Qty | Eco Plan (2) | Lead finish/ Ball material (6) | MSL Peak Temp (3) | Op Temp (°C) | Device Marking (4/5) | Samples |
|------------------|---------------|--------------|-----------------|------|-------------|-----------------|--------------------------------------|----------------------|--------------|-------------------------|-------------------------|
| LP5810ADSDR | ACTIVE | SON | DSD | 8 | 3000 | RoHS & Green | NIPDAU | Level-1-260C-UNLIM | -40 to 85 | 5810A | Samples |
| LP5810AYBHR | ACTIVE | DSBGA | YBH | 9 | 3000 | RoHS & Green | SNAGCU | Level-1-260C-UNLIM | -40 to 85 | 5810A | Samples |
| LP5810BDSDR | ACTIVE | SON | DSD | 8 | 3000 | RoHS & Green | NIPDAU | Level-1-260C-UNLIM | -40 to 85 | 5810B | Samples |
| LP5810BYBHR | ACTIVE | DSBGA | YBH | 9 | 3000 | RoHS & Green | SNAGCU | Level-1-260C-UNLIM | -40 to 85 | 5810B | Samples |
| LP5810CDSDR | ACTIVE | SON | DSD | 8 | 3000 | RoHS & Green | NIPDAU | Level-1-260C-UNLIM | -40 to 85 | 5810C | Samples |
| LP5810CYBHR | ACTIVE | DSBGA | YBH | 9 | 3000 | RoHS & Green | SNAGCU | Level-1-260C-UNLIM | -40 to 85 | 5810C | Samples |
| LP5810DDSDR | ACTIVE | SON | DSD | 8 | 3000 | RoHS & Green | NIPDAU | Level-1-260C-UNLIM | -40 to 85 | 5810D | Samples |
| LP5810DYBHR | ACTIVE | DSBGA | YBH | 9 | 3000 | RoHS & Green | SNAGCU | Level-1-260C-UNLIM | -40 to 85 | 5810D | Samples |

(1) The marketing status values are defined as follows:

ACTIVE: Product device recommended for new designs.

LIFEBUY: TI has announced that the device will be discontinued, and a lifetime-buy period is in effect.

NRND: Not recommended for new designs. Device is in production to support existing customers, but TI does not recommend using this part in a new design.

PREVIEW: Device has been announced but is not in production. Samples may or may not be available.

OBSOLETE: TI has discontinued the production of the device.

(2) **RoHS:** TI defines "RoHS" to mean semiconductor products that are compliant with the current EU RoHS requirements for all 10 RoHS substances, including the requirement that RoHS substance do not exceed 0.1% by weight in homogeneous materials. Where designed to be soldered at high temperatures, "RoHS" products are suitable for use in specified lead-free processes. TI may reference these types of products as "Pb-Free".

RoHS Exempt: TI defines "RoHS Exempt" to mean products that contain lead but are compliant with EU RoHS pursuant to a specific EU RoHS exemption.

Green: TI defines "Green" to mean the content of Chlorine (Cl) and Bromine (Br) based flame retardants meet JS709B low halogen requirements of <=1000ppm threshold. Antimony trioxide based flame retardants must also meet the <=1000ppm threshold requirement.

(3) MSL, Peak Temp. - The Moisture Sensitivity Level rating according to the JEDEC industry standard classifications, and peak solder temperature.

(4) There may be additional marking, which relates to the logo, the lot trace code information, or the environmental category on the device.

(5) Multiple Device Markings will be inside parentheses. Only one Device Marking contained in parentheses and separated by a "~" will appear on a device. If a line is indented then it is a continuation of the previous line and the two combined represent the entire Device Marking for that device.

⁽⁶⁾ Lead finish/Ball material - Orderable Devices may have multiple material finish options. Finish options are separated by a vertical ruled line. Lead finish/Ball material values may wrap to two lines if the finish value exceeds the maximum column width.

Important Information and Disclaimer: The information provided on this page represents TI's knowledge and belief as of the date that it is provided. TI bases its knowledge and belief on information provided by third parties, and makes no representation or warranty as to the accuracy of such information. Efforts are underway to better integrate information from third parties. TI has taken and continues to take reasonable steps to provide representative and accurate information but may not have conducted destructive testing or chemical analysis on incoming materials and chemicals. TI and TI suppliers consider certain information to be proprietary, and thus CAS numbers and other limited information may not be available for release.

In no event shall TI's liability arising out of such information exceed the total purchase price of the TI part(s) at issue in this document sold by TI to Customer on an annual basis.

GENERIC PACKAGE VIEW

DSD 8

WSON - 0.8 mm max height

3 X 3, 0.8 mm pitch

PLASTIC QUAD FLATPACK - NO LEAD

This image is a representation of the package family, actual package may vary.
Refer to the product data sheet for package details.

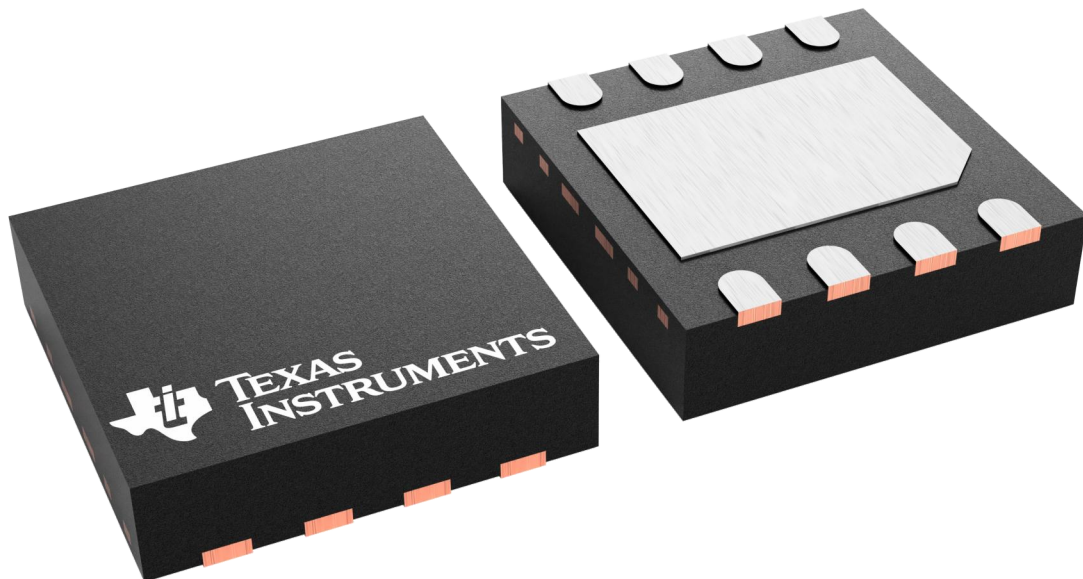

4227007/A

DSD0008B

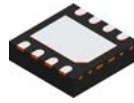

PACKAGE OUTLINE

WSON - 0.8 mm max height

PLASTIC SMALL OUTLINE - NO LEAD

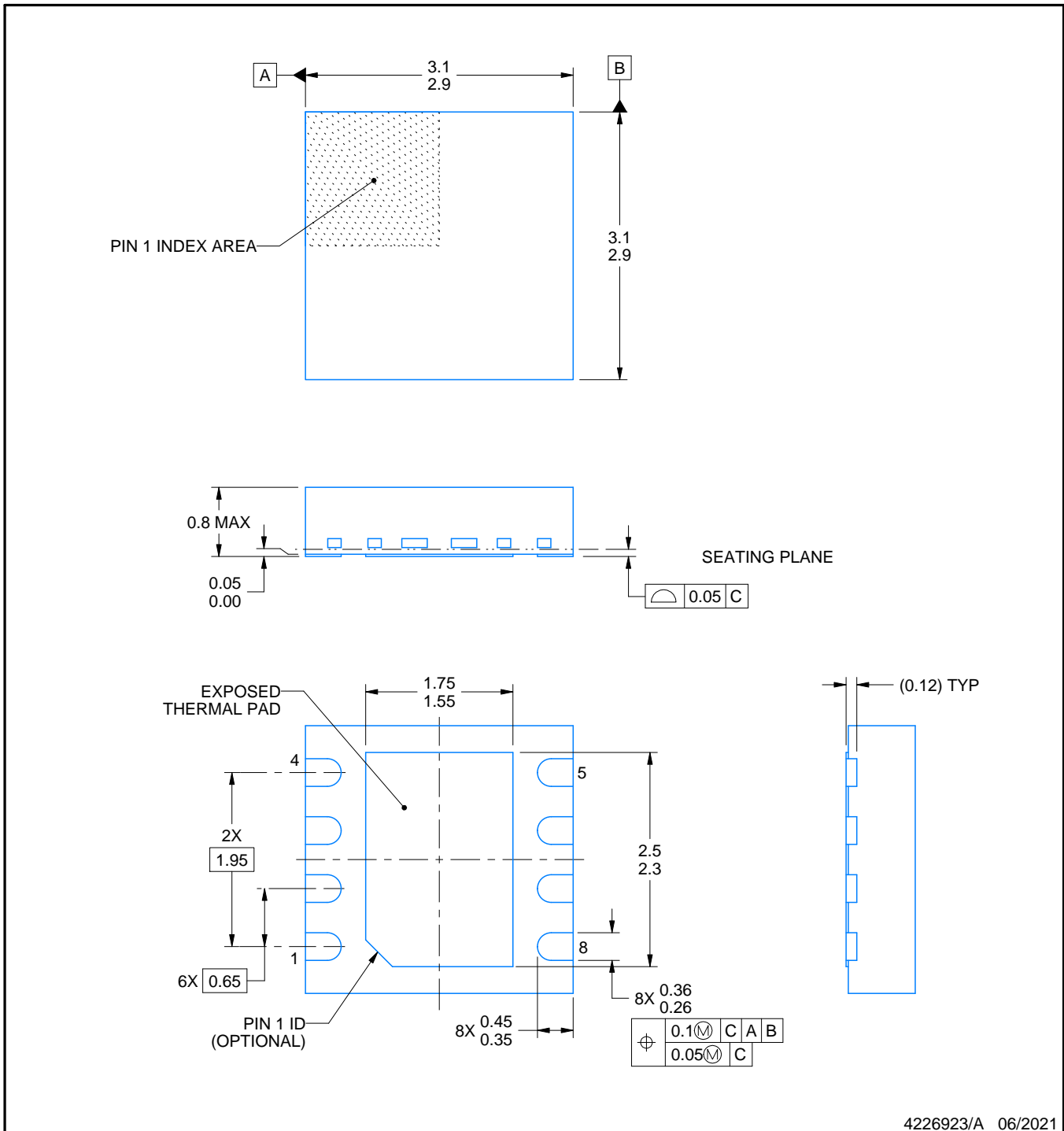

4226923/A 06/2021

NOTES:

1. All linear dimensions are in millimeters. Any dimensions in parenthesis are for reference only. Dimensioning and tolerancing per ASME Y14.5M.
2. This drawing is subject to change without notice.
3. The package thermal pad must be soldered to the printed circuit board for thermal and mechanical performance.

EXAMPLE BOARD LAYOUT

DSD0008B

WSON - 0.8 mm max height

PLASTIC SMALL OUTLINE - NO LEAD

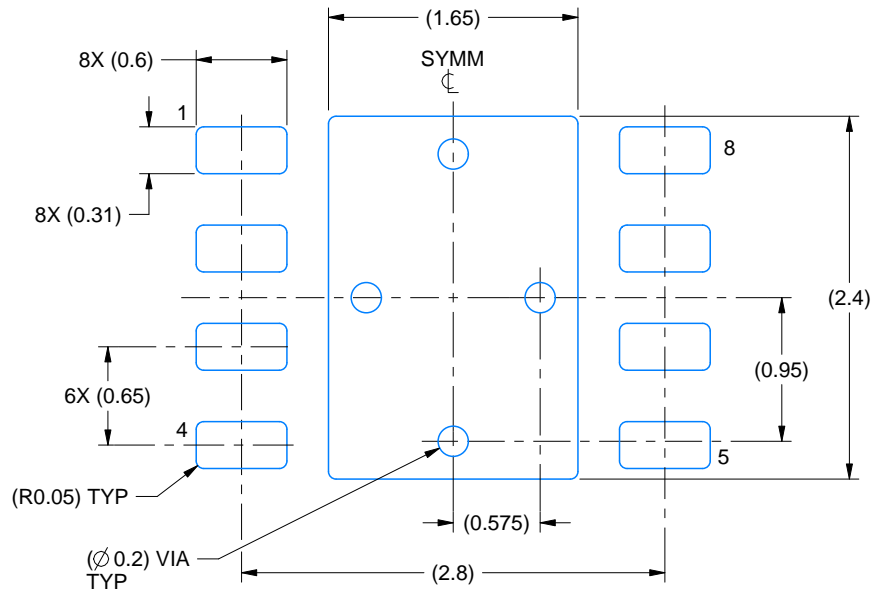

LAND PATTERN EXAMPLE
SCALE:20X

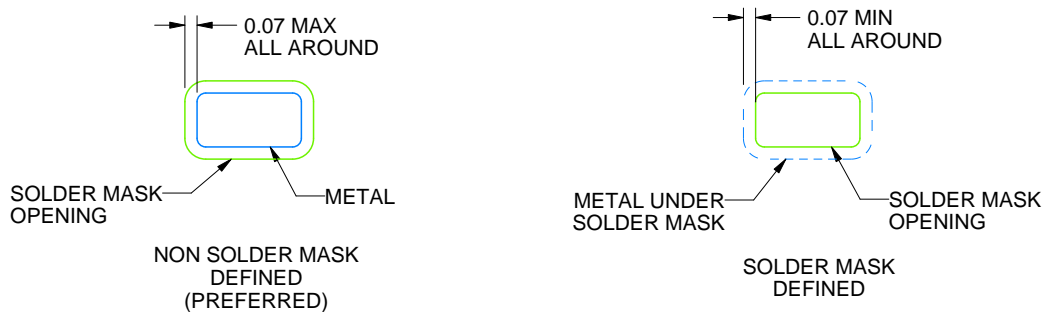

SOLDER MASK DETAILS

4226923/A 06/2021

NOTES: (continued)

4. This package is designed to be soldered to a thermal pad on the board. For more information, see Texas Instruments literature number SLUA271 (www.ti.com/lit/slua271).
5. Vias are optional depending on application, refer to device data sheet. If any vias are implemented, refer to their locations shown on this view. It is recommended that vias under paste be filled, plugged or tented.

EXAMPLE STENCIL DESIGN

DSD0008B

WSON - 0.8 mm max height

PLASTIC SMALL OUTLINE - NO LEAD

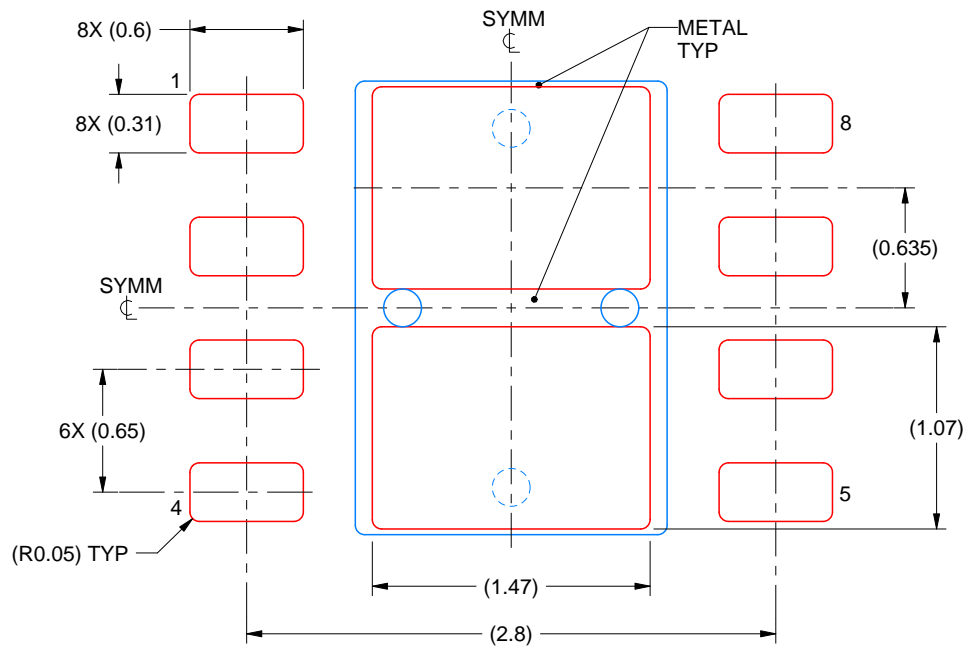

SOLDER PASTE EXAMPLE
BASED ON 0.125 mm THICK STENCIL
EXPOSED PAD
82% PRINTED SOLDER COVERAGE BY AREA
SCALE:25X

4226923/A 06/2021

NOTES: (continued)

6. Laser cutting apertures with trapezoidal walls and rounded corners may offer better paste release. IPC-7525 may have alternate design recommendations.

IMPORTANT NOTICE AND DISCLAIMER

TI PROVIDES TECHNICAL AND RELIABILITY DATA (INCLUDING DATA SHEETS), DESIGN RESOURCES (INCLUDING REFERENCE DESIGNS), APPLICATION OR OTHER DESIGN ADVICE, WEB TOOLS, SAFETY INFORMATION, AND OTHER RESOURCES "AS IS" AND WITH ALL FAULTS, AND DISCLAIMS ALL WARRANTIES, EXPRESS AND IMPLIED, INCLUDING WITHOUT LIMITATION ANY IMPLIED WARRANTIES OF MERCHANTABILITY, FITNESS FOR A PARTICULAR PURPOSE OR NON-INFRINGEMENT OF THIRD PARTY INTELLECTUAL PROPERTY RIGHTS.

These resources are intended for skilled developers designing with TI products. You are solely responsible for (1) selecting the appropriate TI products for your application, (2) designing, validating and testing your application, and (3) ensuring your application meets applicable standards, and any other safety, security, regulatory or other requirements.

These resources are subject to change without notice. TI grants you permission to use these resources only for development of an application that uses the TI products described in the resource. Other reproduction and display of these resources is prohibited. No license is granted to any other TI intellectual property right or to any third party intellectual property right. TI disclaims responsibility for, and you will fully indemnify TI and its representatives against, any claims, damages, costs, losses, and liabilities arising out of your use of these resources.

TI's products are provided subject to [TI's Terms of Sale](#) or other applicable terms available either on [ti.com](https://www.ti.com) or provided in conjunction with such TI products. TI's provision of these resources does not expand or otherwise alter TI's applicable warranties or warranty disclaimers for TI products.

TI objects to and rejects any additional or different terms you may have proposed.

Mailing Address: Texas Instruments, Post Office Box 655303, Dallas, Texas 75265
Copyright © 2023, Texas Instruments Incorporated

X-ON Electronics

Largest Supplier of Electrical and Electronic Components

Click to view similar products for [LED Lighting Drivers](#) category:

Click to view products by [Texas Instruments](#) manufacturer:

Other Similar products are found below :

[LV5235V-MPB-H](#) [AP5726WUG-7](#) [IS31BL3228B-UTLS2-TR](#) [IS31BL3506B-TTLS2-TR](#) [AP5725FDCG-7](#) [AP5726FDCG-7](#) [SLG7NT4082V](#)
[SLG7NT4082VTR](#) [AP5725WUG-7](#) [BD1604MVV-E2](#) [MAX16840ATB+](#) [CAT4004BHU2-GT3](#) [TLE4242EJ](#) [IS31LT3172-GRLS4-TR](#)
[IS32LT3174-GRLA3-TR](#) [ZXLD1374QESTTC](#) [NCV78825DQ0R2G](#) [MP4425AGQB-P](#) [MP3367GR-P](#) [MPQ3369GR-P](#) [MPQ7220GF-AEC1-P](#)
[MP3362GJ-Z](#) [DIO5662ST6](#) [IS31BL3508A-TTLS2-TR](#) [DIO5661TST6](#) [NJW4617DL3-TE1](#) [BD2802GU-E2](#) [BD6583MUV-E2](#)
[NCV7693DB0R2G](#) [LV52207NXA-VH](#) [NCL30076AADR2G](#) [NCL30486B2DR2G](#) [NCL30488B4DR2G](#) [NCV78763MW4AR2G](#)
[BD18353EFV-ME2](#) [A6217KLJTR-T](#) [LT3761EMSE#TRPBF](#) [TLD2132-1EP](#) [MPM6010GQV-AEC1-Z](#) [MPQ4425MGQB-AEC1-Z](#)
[MPQ3326GR-AEC1-Z](#) [MPQ7230GLE-AEC1-Z](#) [MP2341GTL-Z](#) [BCR602](#) [IS31FL3236-TQLS2-TR](#) [TLD700216ESXUMA1](#)
[LM3405AXMYX/NOPB](#) [LM36273YFFR](#) [MP46885DN-LF-Z](#) [MP4056GS-Z](#)