

MSP430FR231x 混合信号微控制器

1 器件概述

1.1 特性

- 嵌入式微控制器
 - 频率高达 16MHz 的 16 位精简指令集计算机 (RISC) 架构
 - 3.6V 至 1.8V 的宽电源电压范围 (最低电源电压受限于 SVS 电平, 请参阅 [SVS 规格](#))
- 经优化的低功耗模式 (3V 时)
 - 激活模式: 126 μ A/MHz
 - 待机模式: 实时时钟 (RTC) 计数器 (LPM3.5, 采用 32768Hz 晶振) 0.71 μ A
 - 关断模式 (LPM4.5): 32nA (无 SVS)
- 高性能模拟
 - 跨阻放大器 (TIA)⁽¹⁾
 - 电流至电压转换
 - 半轨输入
 - 仅针对 TSSOP16 封装, 将低泄漏负输入降至 5pA
 - 轨至轨输出
 - 多个输入信号选项
 - 可配置的高功率和低功率模式
 - 8 通道 10 位模数转换器 (ADC)
 - 1.5V 的内部基准电压
 - 采样与保持 200kps
 - 增强型比较器 (eCOMP)
 - 集成 6 位数模转换器 (DAC) 作为基准电压
 - 可编程迟滞
 - 可配置的高功率和低功率模式
 - 智能模拟组合 (SAC-L1)
 - 支持通用运算放大器
 - 轨至轨输入和输出
 - 多个输入信号选项
 - 可配置的高功率和低功率模式
- 低功耗铁电 RAM (FRAM)
 - 非易失性存储器容量高达 3.75KB
 - 内置错误修正码 (ECC)
 - 可配置的写保护
 - 对程序、常量和存储的统一存储
- 耐写次数达 10¹⁵ 次
- 抗辐射和非磁性
- 智能数字外设
 - 红外调制逻辑
 - 两个 16 位计时器, 每个计时器有 3 个捕捉/比较寄存器 (Timer_B3)
 - 一个仅用作计数器的 16 位 RTC 计数器
 - 16 位循环冗余校验器 (CRC)
- 增强型串行通信
 - 增强型 USCI A (eUSCI_A) 支持 UART、IrDA 和 SPI
 - 增强型 USCI B (eUSCI_B) 支持 SPI 和 I²C, 并提供重映射功能 (请参阅 [信号说明](#))
- 时钟系统 (CS)
 - 片上 32kHz RC 振荡器 (REFO)
 - 带有锁频环 (FLL) 的片上 16MHz 数控振荡器 (DCO)
 - 室温下的精度为 $\pm 1\%$ (具有片上基准)
 - 片上超低频 10kHz 振荡器 (VLO)
 - 片上高频调制振荡器 (MODOSC)
 - 外部 32kHz 晶振 (LFXT)
 - 外部高频晶体振荡器, 频率高达 16MHz (HFXT)
 - 可编程 MCLK 预分频器 (1 至 128)
 - 通过可编程预分频器 (1、2、4 或 8) 从 MCLK 获得的 SMCLK
- 通用输入/输出和引脚功能
 - 20 引脚封装有 16 个 I/O
 - 12 个中断引脚 (8 个 P1 引脚和 4 个 P2 引脚) 可将 MCU 从 LPM 唤醒
 - 所有 I/O 均为电容式触控 I/O
- 开发工具和软件
 - LaunchPad™ 开发套件 ([MSP-EXP430FR2311](#))
 - 目标开发板 ([MSP-TS430PW20](#))
- 系列成员 (另请参阅 [器件比较](#))
 - MSP430FR2311: 3.75KB 程序 FRAM 和 1KB RAM
 - MSP430FR2310: 2KB 程序 FRAM 和 1KB RAM

(1) 以前, 跨阻放大器在描述性文字、引脚名称和电阻器名称中的缩写都是 TRI。现在将所有描述性文字中的缩写改成了 TIA, 但引脚名称和电阻器名称仍然使用 TRI。



- 封装选项
 - 20 引脚 TSSOP (PW20)
 - 16 引脚 TSSOP (PW16)
 - 16 引脚 VQFN (RGY16)

1.2 应用

- 烟雾探测器
- 移动电源
- 便携式保健和健身设备
- 电源监控
- 个人电子产品

1.3 说明

MSP430FR231x FRAM 微控制器 (MCU) 属于 MSP430™ MCU 超值系列检测系列中的一员。这些器件集成了可配置的低泄漏跨阻放大器 (TIA) 和通用运算放大器。MCU 具有功能强大的 16 位 RISC CPU、16 位寄存器和常数发生器，有助于实现最大编码效率。数控振荡器 (DCO) 还可以让器件在不到 10μs 的时间内从低功耗模式唤醒至活动模式。这些 MCU 的功能集非常适合从烟雾探测器到便携式医疗和健身配件等多种应用。

超低功耗的 MSP430FR231x MCU 系列包含多种器件，其中配备了嵌入式非易失性 FRAM 和不同的外设集，适用于各种检测和测量应用中的数字输入 D 类音频放大器。该架构、FRAM 和外设与多种低功耗模式相结合，专为在便携式无线感测应用中延长电池使用寿命而进行了优化中的数字输入 D 类音频放大器。FRAM 是一种非易失性存储器技术，它将 SRAM 的速度、灵活性和耐用性与闪存的稳定性和可靠性相结合，并且总功耗更低。

MSP430FR231x MCU 由一个由各种软、硬件资源组成的生态系统提供支持，并配套提供有参考设计和代码示例，可帮助您快速开展设计。开发套件包括 MSP-EXP430FR2311 LaunchPad™ 开发套件和 MSP-TS430PW20 20 引脚目标开发板。TI 提供免费的 MSP430Ware™ 软件，可作为 Code Composer Studio™ IDE 台式机和云版本（位于 TI Resource Explorer）的组件。MSP430 MCU 还通过 E2E™ 社区论坛提供广泛的在线配套资料、培训和在线支持。

有关完整的模块说明，请参阅《MSP430FR4xx 和 MSP430FR2xx 系列器件用户指南》。

器件信息⁽¹⁾

| 器件型号 | 封装 | 封装尺寸 ⁽²⁾ |
|------------------|------------|---------------------|
| MSP430FR2311PW20 | TSSOP (20) | 6.5mm × 4.4mm |
| MSP430FR2310PW20 | | |
| MSP430FR2311PW16 | TSSOP (16) | 5mm × 4.4mm |
| MSP430FR2310PW16 | | |
| MSP430FR2311IRGY | VQFN (16) | 4mm × 3.5mm |
| MSP430FR2310IRGY | | |

(1) 要获得最新的产品、封装和订购信息，请参见封装选项附录（节 9），或者访问德州仪器 (TI) 网站 www.ti.com.cn。

(2) 这里显示的尺寸为近似值。要获得包含误差值的封装尺寸，请参见机械数据（节 9 中）。

CAUTION

系统级静电放电 (ESD) 保护必须符合器件级 ESD 规范，以防发生电气过载或对数据或代码存储器造成干扰。有关更多信息，请参阅《MSP430™ 系统级 ESD 注意事项》。

1.4 功能框图

图 1-1 所示为功能框图。



图 1-1. MSP430FR231x 功能方框图

- MCU 的主电源对 DVCC 和 DVSS 分别为数字模块和模拟模块供电。推荐的旁路电容和去耦电容分别为 4.7 μ F 至 10 μ F 和 0.1 μ F，精度为 $\pm 5\%$ 。
- P1 的 8 个引脚和 P2 的 4 个引脚均具备引脚中断功能，可将 MCU 从所有低功耗模式 (LPM) 唤醒（包括 LPM4、LPM3.5 和 LPM4.5）。
- 每个 Timer_B3 具有三个捕捉/比较寄存器。仅 CCR1 和 CCR2 从外部连接。CCR0 寄存器仅用于内部周期时序和生成中断。
- 在 LPM3.5 模式下，RTC 计数器与备用存储器可继续工作，而其余外设停止工作。
- 所有通用 I/O 均可配置为电容式触控 I/O。

内容

| | | | | | |
|----------|--|---------------------------|----------|---|---------------------------|
| 1 | 器件概述 | 1 | 6 | Detailed Description | 44 |
| 1.1 | 特性 | 1 | 6.1 | Overview | 44 |
| 1.2 | 应用 | 2 | 6.2 | CPU | 44 |
| 1.3 | 说明 | 2 | 6.3 | Operating Modes | 44 |
| 1.4 | 功能框图 | 2 | 6.4 | Interrupt Vector Addresses | 46 |
| 2 | 修订历史记录 | 5 | 6.5 | Memory Organization | 47 |
| 3 | Device Comparison | 7 | 6.6 | Bootloader (BSL) | 47 |
| 3.1 | Related Products | 7 | 6.7 | JTAG Standard Interface | 48 |
| 4 | Terminal Configuration and Functions | 8 | 6.8 | Spy-Bi-Wire Interface (SBW) | 48 |
| 4.1 | Pin Diagrams | 8 | 6.9 | FRAM | 48 |
| 4.2 | Pin Attributes | 10 | 6.10 | Memory Protection | 49 |
| 4.3 | Signal Descriptions | 12 | 6.11 | Peripherals | 50 |
| 4.4 | Pin Multiplexing | 14 | 6.12 | Input/Output Diagrams | 68 |
| 4.5 | Buffer Type | 14 | 6.13 | Device Descriptors (TLV) | 72 |
| 4.6 | Connection of Unused Pins | 14 | 6.14 | Identification | 73 |
| 5 | Specifications | 15 | 7 | Applications, Implementation, and Layout | 74 |
| 5.1 | Absolute Maximum Ratings | 15 | 7.1 | Device Connection and Layout Fundamentals | 74 |
| 5.2 | ESD Ratings | 15 | 7.2 | Peripheral- and Interface-Specific Design Information | 77 |
| 5.3 | Recommended Operating Conditions | 15 | 7.3 | Typical Applications | 78 |
| 5.4 | Active Mode Supply Current Into V_{CC} Excluding External Current | 16 | 8 | 器件和文档支持 | 79 |
| 5.5 | Active Mode Supply Current Per MHz | 16 | 8.1 | 使用入门 | 79 |
| 5.6 | Low-Power Mode LPM0 Supply Currents Into V_{CC} Excluding External Current | 16 | 8.2 | 器件命名规则 | 79 |
| 5.7 | Low-Power Mode LPM3 and LPM4 Supply Currents (Into V_{CC}) Excluding External Current | 17 | 8.3 | 工具和软件 | 80 |
| 5.8 | Low-Power Mode LPMx.5 Supply Currents (Into V_{CC}) Excluding External Current | 18 | 8.4 | 文档支持 | 82 |
| 5.9 | Production Distribution of LPM Supply Currents | 19 | 8.5 | 相关链接 | 83 |
| 5.10 | Typical Characteristics – Current Consumption Per Module | 20 | 8.6 | 社区资源 | 83 |
| 5.11 | Thermal Resistance Characteristics | 20 | 8.7 | 商标 | 83 |
| 5.12 | Timing and Switching Characteristics | 21 | 8.8 | 静电放电警告 | 83 |
| | | | 8.9 | Glossary | 83 |
| | | | 9 | 机械、封装和可订购信息 | 84 |

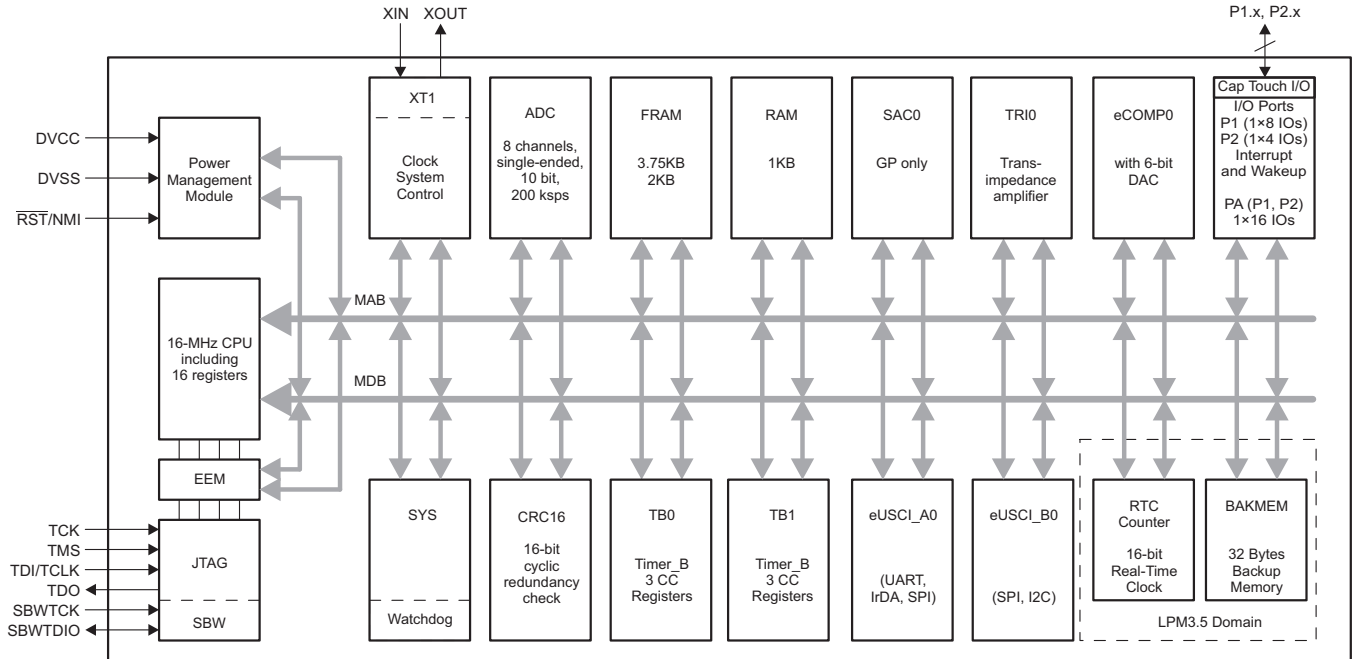
2 修订历史记录

注：之前版本的页码可能与当前版本有所不同。

从修订版本 D 更改为修订版本 E

| Changes from August 29, 2018 to December 9, 2019 | Page |
|---|--------------------|
| • Updated Section 3.1, Related Products | 7 |
| • Changed the note that begins "Supply voltage changes faster than 0.2 V/μs can trigger a BOR reset..." in Section 5.3, Recommended Operating Conditions | 15 |
| • Added the note that begins "TI recommends that power to the DVCC pin must not exceed the limits..." in Section 5.3, Recommended Operating Conditions | 15 |
| • Changed the note that begins "A capacitor tolerance of ±20% or better is required..." in Section 5.3, Recommended Operating Conditions | 15 |
| • Combined former sections 5.8 and 5.10 to Section 5.9, Production Distribution of LPM Supply Currents | 19 |
| • Corrected "SVS Enabled" test condition on Figure 5-2, LPM3.5 Supply Current vs Temperature | 19 |
| • Added the note "See MSP430 32-kHz Crystal Oscillators for details on crystal section, layout, and testing" to Table 5-3, XT1 Crystal Oscillator (Low Frequency) | 23 |
| • Changed the note that begins "Requires external capacitors at both terminals..." in Table 5-3, XT1 Crystal Oscillator (Low Frequency) | 23 |
| • Added the $t_{TB,cap}$ parameter in Table 5-13, Timer_B | 30 |
| • Changed the parameter symbol from R_i to $R_{i,MUX}$ in Table 5-20, ADC, Power Supply and Input Range Conditions .. | 36 |
| • Corrected the test conditions for the $R_{i,MUX}$ parameter in Table 5-20, ADC, Power Supply and Input Range Conditions | 36 |
| • Added $R_{i,Misc}$ TYP value of 34 kΩ in Table 5-20, ADC, Power Supply and Input Range Conditions | 36 |
| • Added formula for R_i in Table 5-21, ADC, 10-Bit Timing Parameters | 36 |
| • Added the note that begins " $t_{Sample} = \ln(2^{n+1}) \times \tau$..." in Table 5-21, ADC, 10-Bit Timing Parameters | 36 |
| • Corrected bitfield from RTCCLK to RTCKSEL in Table 6-8, Clock Distribution | 51 |
| • Corrected bitfield from IRDSEL to IRDSSEL in Section 6.11.8, Timers (Timer0_B3, Timer1_B3) , in the description that starts "The interconnection of Timer0_B3 and ..." | 54 |
| • Added P1SEL0 information in Table 6-31, Port P1, P2 Registers (Base Address: 0200h) | 65 |
| • Added P2SEL0 information in Table 6-31, Port P1, P2 Registers (Base Address: 0200h) | 65 |
| • Added note to "ADC calibration" in Table 6-46, Device Descriptors | 72 |

从修订版本 C 更改为修订版本 D

| Changes from September 12, 2017 to August 28, 2018 | Page |
|--|--------------------|
| • Updated Section 3.1, Related Products | 7 |
| • Combined former sections 5.8 and 5.10 to Section 5.9, Production Distribution of LPM Supply Currents | 19 |
| • Added note to V_{SVSH-} and V_{SVSH+} parameters in Table 5-1, PMM, SVS and BOR | 21 |
| • Added the $t_{TB,cap}$ parameter in Table 5-13, Timer_B | 30 |
| • Corrected ADCINCHx column heading in Table 6-16, ADC Channel Connections | 58 |
| • 更新了 节 8.2 器件命名规则 中的文本和图 | 79 |

从修订版本 B 更改为修订版本 C

| Changes from June 1, 2016 to September 11, 2017 | Page |
|---|--------------------|
| • 更正了“关断模式 (LPM4.5)”特性列表项中的电流 | 1 |
| • 根据测试数据，低泄漏输入从 50pA 降为 5pA | 1 |
| • Added Section 3.1, Related Products | 7 |
| • Combined former sections 5.8 and 5.10 to Section 5.9, Production Distribution of LPM Supply Currents | 19 |
| • Added the $t_{TB,cap}$ parameter in Table 5-13, Timer_B | 30 |
| • Removed ADCDIV from the formula for the TYP value in the second row of the $t_{CONVERT}$ parameter in Table 5-21, ADC, 10-Bit Timing Parameters (removed because ADCCLK is after division)..... | 36 |
| • Changed the entries for eUSCI_A0 and eUSCI_B0 in the LPM3 column from Off to Optional in Table 6-1, | |

| | |
|--|--------------------|
| <i>Operating Modes</i> | 45 |
| • Added the sentence that begins "This device supports blank device detection..." in Section 6.6, Bootloader (BSL) .. | 47 |
| • Added the note "Controlled by the RTCCLK bit in the SYSCFG2 register" on Table 6-8, Clock Distribution | 51 |
| • Added Figure 6-1, Clock Distribution Block Diagram | 51 |
| • Added Figure 6-2, Timer_B Connections | 55 |
| • Removed SYSBERRIV register (not supported) in Table 6-26, SYS Registers | 64 |
| • Changed from "If the $\overline{\text{RST}}/\text{NMI}$ pin is unused...with a 2.2-nF pulldown capacitor" to "If the $\overline{\text{RST}}/\text{NMI}$ pin is unused...with a 10-nF pulldown capacitor" | 76 |

从修订版本 A 更改为修订版本 B

| Changes from March 30, 2016 to May 31, 2016 | Page |
|--|--------------------|
| • 将器件状态从“产品预发布”更改为“生产数据” | 1 |
| • Changed the value of f_{XT1} in the table note that starts "Low-power mode 4, VLO,..." | 17 |
| • Combined former sections 5.8 and 5.10 to Section 5.9, Production Distribution of LPM Supply Currents | 19 |
| • Added Test Conditions to module Timer_B in Section 5.10, Typical Characteristics – Current Consumption Per Module | 20 |
| • Added "16 MHz" to the parameter description of $t_{\text{FLL, lock}}$ in Table 5-5, DCO FLL | 25 |
| • Added the $t_{\text{TB, cap}}$ parameter in Table 5-13, Timer_B | 30 |
| • Removed $\pm 3^\circ\text{C}$ from calibration temperatures in the table note that starts "The device descriptor structure contains calibration values..." | 37 |
| • Changed the unit on the E_{NI} parameter in Table 5-24, SAC0 (SAC-L1, OA) | 39 |
| • Changed the unit on the E_{NI} parameter in Table 5-25, TIA0 | 40 |

从初始发行版更改为修订版本 A

| Changes from February 23, 2016 to March 29, 2016 | Page |
|---|--------------------|
| • 已将整篇文档中 TIA 模块的名称由“TRIO”更改为“TIA0” | 2 |
| • Changed TYP values for the $I_{\text{AM, FRAM}}(0\%)$ parameter in Section 5.4, Active Mode Supply Current Into V_{CC} Excluding External Current | 16 |
| • Combined former sections 5.8 and 5.10 to Section 5.9, Production Distribution of LPM Supply Currents | 19 |
| • Added the $t_{\text{TB, cap}}$ parameter in Table 5-13, Timer_B | 30 |
| • Changed MAX values of the $t_{\text{VALID, SO}}$ parameter in Table 5-18, eUSCI (SPI Slave Mode) Switching Characteristics | 33 |
| • Changed the TYP value of the CMRR parameter with Test Conditions of "TRIPM = 0" from 70 dB to 80 dB in Table 5-25, TIA0 | 40 |
| • Changed the TYP value of the PSRR parameter with Test Conditions of "TRIPM = 0" from 70 dB to 80 dB in Table 5-25, TIA0 | 40 |
| • 已将旧版中的开发工具支持部分替换为 节 8.3, 工具和软件 | 80 |

3 Device Comparison

Table 3-1 summarizes the features of the available family members.

Table 3-1. Device Comparison⁽¹⁾ ⁽²⁾

| DEVICE | PROGRAM FRAM (KB) | SRAM (Bytes) | TB0, TB1 | eUSCI_A | eUSCI_B | 10-BIT ADC CHANNELS | SAC0 (OA) | TIA0 | eCOMP0 | I/O | PACKAGE |
|-------------------|-------------------|--------------|-------------------------|---------|---------|---------------------|-----------|------|--------|-----|---------------|
| MSP430FR2311IPW20 | 3.75 | 1024 | 3 CCR ⁽³⁾ | 1 | 1 | 8 | 1 | 1 | 1 | 16 | 20 PW (TSSOP) |
| MSP430FR2310IPW20 | 2 | 1024 | 3 CCR ⁽³⁾ | 1 | 1 | 8 | 1 | 1 | 1 | 16 | 20 PW (TSSOP) |
| MSP430FR2311IPW16 | 3.75 | 1024 | 3 CCR ⁽³⁾⁽⁴⁾ | 1 | 1 | 8 | 1 | 1 | 1 | 11 | 16 PW (TSSOP) |
| MSP430FR2310IPW16 | 2 | 1024 | 3 CCR ⁽³⁾⁽⁴⁾ | 1 | 1 | 8 | 1 | 1 | 1 | 11 | 16 PW (TSSOP) |
| MSP430FR2311IRGY | 3.75 | 1024 | 3 CCR ⁽³⁾ | 1 | 1 | 8 | 1 | 1 | 1 | 12 | 16 RGY (VQFN) |
| MSP430FR2310IRGY | 2 | 1024 | 3 CCR ⁽³⁾ | 1 | 1 | 8 | 1 | 1 | 1 | 12 | 16 RGY (VQFN) |

- (1) For the most current device, package, and ordering information, see the *Package Option Addendum* in [§ 9](#), or see the TI website at www.ti.com.
- (2) Package drawings, standard packing quantities, thermal data, symbolization, and PCB design guidelines are available at www.ti.com/packaging.
- (3) A CCR register is a configurable register that provides internal and external capture or compare inputs, or internal and external PWM outputs.
- (4) TB1 provides only one external connection (TB1.1) on this package.

3.1 Related Products

For information about other devices in this family of products or related products, see the following links.

[TI 16-bit and 32-bit microcontrollers](#)

High-performance, low-power solutions to enable the autonomous future

[Products for MSP430 ultra-low-power sensing & measurement MCUs](#)

One platform. One ecosystem. Endless possibilities.

[Companion products for MSP430FR2311](#)

Review products that are frequently purchased or used with this product.

[Reference designs for MSP430FR2311](#)

Find reference designs leveraging the best in TI technology – from analog and power management to embedded processors

4 Terminal Configuration and Functions

4.1 Pin Diagrams

Figure 4-1 shows the pinout of the 20-pin PW package.

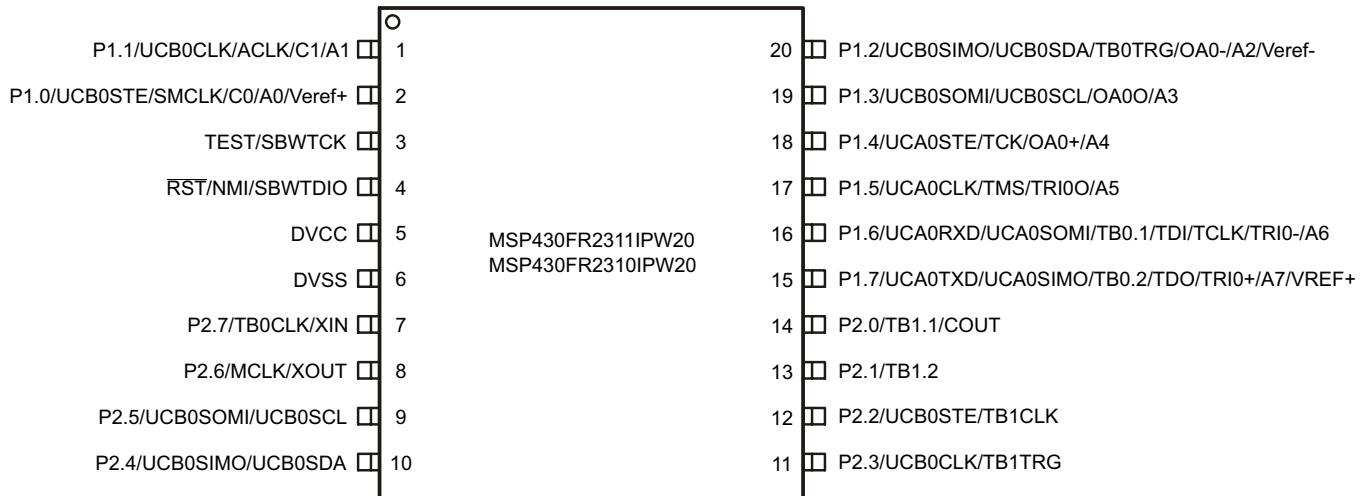

Figure 4-1. 20-Pin PW (TSSOP) (Top View)

Figure 4-2 shows the pinout of the 16-pin PW package.

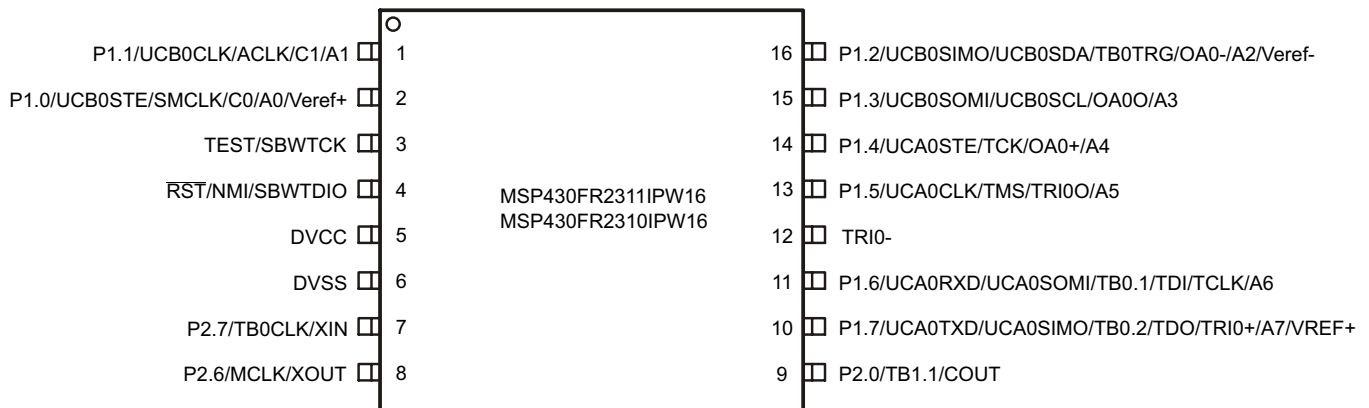

Figure 4-2. 16-Pin PW (TSSOP) (Top View)

Figure 4-3 shows the pinout of the 16-pin RGY package.

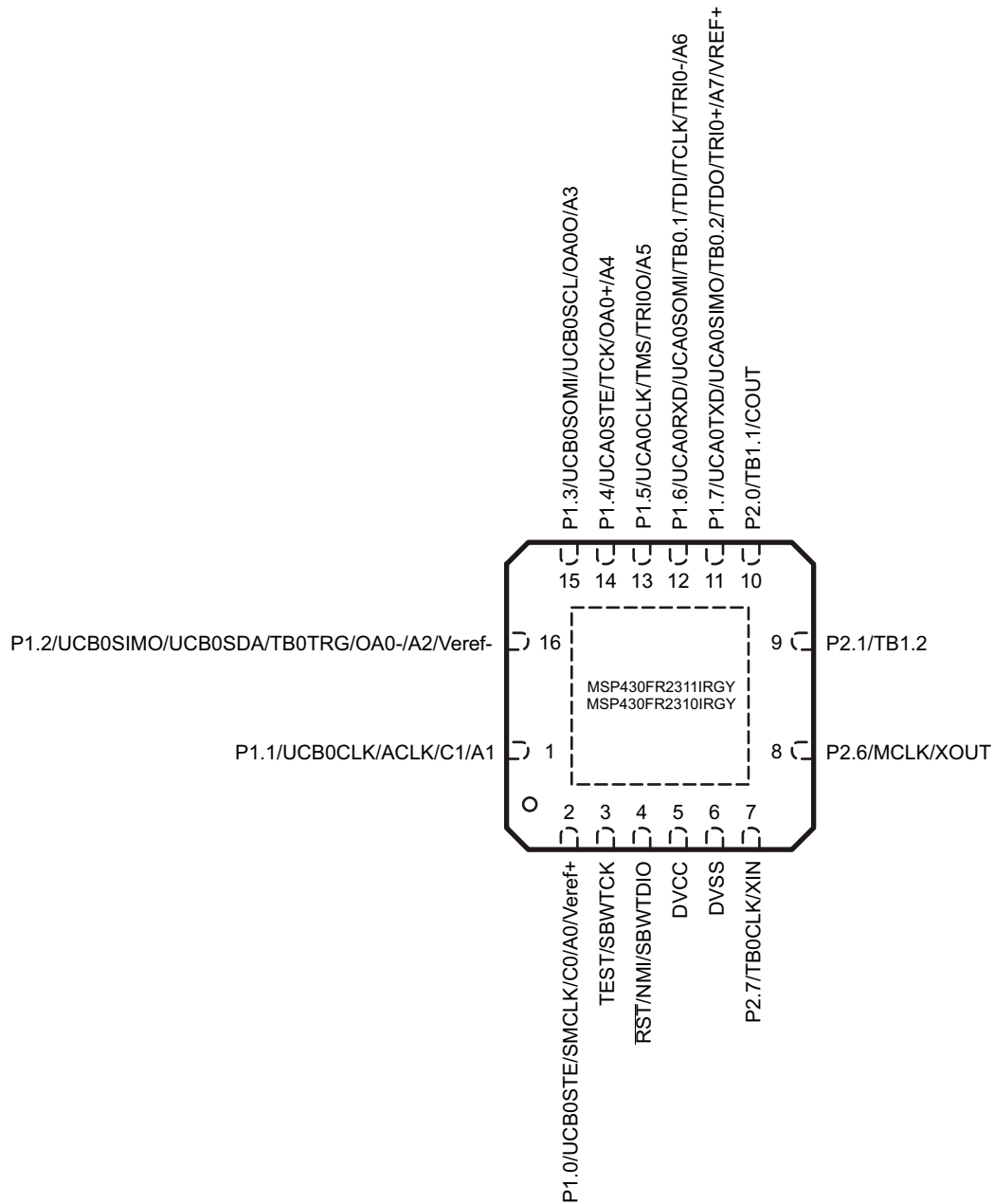

Figure 4-3. 16-Pin RGY (VQFN) (Top View)

4.2 Pin Attributes

Table 4-1 lists the attributes of all pins.

Table 4-1. Pin Attributes

| PIN NUMBER | | | SIGNAL NAME ^{(1) (2)} | SIGNAL TYPE ⁽³⁾ | BUFFER TYPE ⁽⁴⁾ | POWER SOURCE | RESET STATE AFTER BOR ⁽⁵⁾ |
|------------|-----|------|--------------------------------|----------------------------|----------------------------|--------------|--------------------------------------|
| PW20 | RGY | PW16 | | | | | |
| 1 | 1 | 1 | P1.1 (RD) | I/O | LVC MOS | DVCC | OFF |
| | | | UCB0CLK | I/O | LVC MOS | DVCC | N/A |
| | | | ACLK | O | LVC MOS | DVCC | N/A |
| | | | C1 | I | Analog | DVCC | N/A |
| | | | A1 | I | Analog | DVCC | N/A |
| 2 | 2 | 2 | P1.0 (RD) | I/O | LVC MOS | DVCC | OFF |
| | | | UCB0STE | I/O | LVC MOS | DVCC | N/A |
| | | | SMCLK | O | LVC MOS | DVCC | N/A |
| | | | C0 | I | Analog | DVCC | N/A |
| | | | A0 | I | Analog | DVCC | N/A |
| | | | Veref+ | I | Power | DVCC | N/A |
| 3 | 3 | 3 | TEST (RD) | I | LVC MOS | DVCC | OFF |
| | | | SBWTCK | I | LVC MOS | DVCC | N/A |
| 4 | 4 | 4 | $\overline{\text{RST}}$ (RD) | I/O | LVC MOS | DVCC | OFF |
| | | | NMI | I | LVC MOS | DVCC | N/A |
| | | | SBWTDIO | I/O | LVC MOS | DVCC | N/A |
| 5 | 5 | 5 | DVCC | P | Power | DVCC | N/A |
| 6 | 6 | 6 | DVSS | P | Power | DVCC | N/A |
| 7 | 7 | 7 | P2.7 (RD) | I/O | LVC MOS | DVCC | OFF |
| | | | TB0CLK | I | LVC MOS | DVCC | N/A |
| | | | XIN | I | LVC MOS | DVCC | N/A |
| 8 | 8 | 8 | P2.6 (RD) | I/O | LVC MOS | DVCC | OFF |
| | | | MCLK | O | LVC MOS | DVCC | N/A |
| | | | XOUT | O | LVC MOS | DVCC | N/A |
| 9 | – | – | P2.5 (RD) | I/O | LVC MOS | DVCC | OFF |
| | | | UCB0SOMI | I/O | LVC MOS | DVCC | N/A |
| | | | UCB0SCL | I/O | LVC MOS | DVCC | N/A |
| 10 | – | – | P2.4 (RD) | I/O | LVC MOS | DVCC | OFF |
| | | | UCB0SIMO | I/O | LVC MOS | DVCC | N/A |
| | | | UCB0SDA | I/O | LVC MOS | DVCC | N/A |
| 11 | – | – | P2.3 (RD) | I/O | LVC MOS | DVCC | OFF |
| | | | UCB0CLK | I/O | LVC MOS | DVCC | N/A |
| | | | TB1TRG | I | LVC MOS | DVCC | N/A |
| 12 | – | – | P2.2 (RD) | I/O | LVC MOS | DVCC | OFF |
| | | | UCB0STE | I/O | LVC MOS | DVCC | N/A |
| | | | TB1CLK | I | LVC MOS | DVCC | N/A |
| 13 | 9 | – | P2.1 (RD) | I/O | LVC MOS | DVCC | OFF |
| | | | TB1.2 | I/O | LVC MOS | DVCC | N/A |

(1) Signals names with (RD) denote the reset default pin name.

(2) To determine the pin mux encodings for each pin, see [Section 6.12, Input/Output Diagrams](#).

(3) Signal Types: I = Input, O = Output, I/O = Input or Output.

(4) Buffer Types: LVC MOS, Analog, or Power

(5) Reset States:

OFF = High-impedance input with pullup or pulldown disabled (if available)

N/A = Not applicable

Table 4-1. Pin Attributes (continued)

| PIN NUMBER | | | SIGNAL NAME ⁽¹⁾ (2) | SIGNAL TYPE ⁽³⁾ | BUFFER TYPE ⁽⁴⁾ | POWER SOURCE | RESET STATE AFTER BOR ⁽⁵⁾ |
|------------|-----|------|--------------------------------|----------------------------|----------------------------|--------------|--------------------------------------|
| PW20 | RGY | PW16 | | | | | |
| 14 | 10 | 9 | P2.0 (RD) | I/O | LVC MOS | DVCC | OFF |
| | | | TB1.1 | I/O | LVC MOS | DVCC | N/A |
| | | | CO UT | O | LVC MOS | DVCC | N/A |
| 15 | 11 | 10 | P1.7 (RD) | I/O | LVC MOS | DVCC | OFF |
| | | | UCA0TXD | O | LVC MOS | DVCC | N/A |
| | | | UCA0SIMO | I/O | LVC MOS | DVCC | N/A |
| | | | TB0.2 | I/O | LVC MOS | DVCC | N/A |
| | | | TDO | O | LVC MOS | DVCC | N/A |
| | | | TRI0+ | I | Analog | DVCC | N/A |
| | | | A7 | I | Analog | DVCC | N/A |
| | | | VREF+ | O | Power | DVCC | N/A |
| 16 | 12 | 11 | P1.6 (RD) | I/O | LVC MOS | DVCC | OFF |
| | | | UCA0RXD | I | LVC MOS | DVCC | N/A |
| | | | UCA0SOMI | I/O | LVC MOS | DVCC | N/A |
| | | | TB0.1 | I/O | LVC MOS | DVCC | N/A |
| | | | TDI | I | LVC MOS | DVCC | N/A |
| | | | TCLK | I | LVC MOS | DVCC | N/A |
| | | | TRI0- ⁽⁶⁾ | I | Analog | DVCC | N/A |
| | | | A6 | I | Analog | DVCC | N/A |
| – | – | 12 | TRI0- | I | Analog | DVCC | N/A |
| 17 | 13 | 13 | P1.5 (RD) | I/O | LVC MOS | DVCC | OFF |
| | | | UCA0CLK | I/O | LVC MOS | DVCC | N/A |
| | | | TMS | I | LVC MOS | DVCC | N/A |
| | | | TRI0O | O | Analog | DVCC | N/A |
| | | | A5 | I | Analog | DVCC | N/A |
| 18 | 14 | 14 | P1.4 (RD) | I/O | LVC MOS | DVCC | OFF |
| | | | UCA0STE | I/O | LVC MOS | DVCC | N/A |
| | | | TCK | I | LVC MOS | DVCC | N/A |
| | | | OA0+ | I | Analog | DVCC | N/A |
| | | | A4 | I | Analog | DVCC | N/A |
| 19 | 15 | 15 | P1.3 (RD) | I/O | LVC MOS | DVCC | OFF |
| | | | UCB0SOMI | I/O | LVC MOS | DVCC | N/A |
| | | | UCB0SCL | I/O | LVC MOS | DVCC | N/A |
| | | | OA0O | O | Analog | DVCC | N/A |
| | | | A3 | I | Analog | DVCC | N/A |
| 20 | 16 | 16 | P1.2 (RD) | I/O | LVC MOS | DVCC | OFF |
| | | | UCB0SIMO | I/O | LVC MOS | DVCC | N/A |
| | | | UCB0SDA | I/O | LVC MOS | DVCC | N/A |
| | | | TB0TRG | I | LVC MOS | DVCC | N/A |
| | | | OA0- | I | Analog | DVCC | N/A |
| | | | A2 | I | Analog | DVCC | N/A |
| | | | Veref- | I | Power | DVCC | N/A |

(6) Not available on TSSOP-16 package

4.3 Signal Descriptions

Table 4-2 describes the signals for all device variants and package options.

Table 4-2. Signal Descriptions

| FUNCTION | SIGNAL NAME | PIN NUMBER | | | PIN TYPE | DESCRIPTION |
|----------|---------------|------------|-----|------|------------------------|---|
| | | PW20 | RGY | PW16 | | |
| ADC | A0 | 2 | 2 | 2 | I | Analog input A0 |
| | A1 | 1 | 1 | 1 | I | Analog input A1 |
| | A2 | 20 | 16 | 16 | I | Analog input A2 |
| | A3 | 19 | 15 | 15 | I | Analog input A3 |
| | A4 | 18 | 14 | 14 | I | Analog input A4 |
| | A5 | 17 | 13 | 13 | I | Analog input A5 |
| | A6 | 16 | 12 | 11 | I | Analog input A6 |
| | A7 | 15 | 11 | 10 | I | Analog input A7 |
| | Veref+ | 2 | 2 | 2 | I | ADC positive reference |
| Veref- | 20 | 16 | 16 | I | ADC negative reference | |
| eCOMP0 | C0 | 2 | 2 | 2 | I | Comparator input channel C0 |
| | C1 | 1 | 1 | 1 | I | Comparator input channel C1 |
| | COU \bar{T} | 14 | 10 | 9 | O | Comparator output channel COU \bar{T} |
| TIA0 | TRIO+ | 15 | 11 | 10 | I | TIA0 positive input |
| | TRIO- | 16 | 12 | 12 | I | TIA0 negative input |
| | TRIOO | 17 | 13 | 13 | O | TIA0 output |
| SAC0 | OA0+ | 18 | 14 | 14 | I | SAC0, OA positive input |
| | OA0- | 20 | 16 | 16 | I | SAC0, OA negative input |
| | OA0O | 19 | 15 | 15 | O | SAC0, OA output |
| Clock | ACLK | 1 | 1 | 1 | O | ACLK output |
| | MCLK | 8 | 8 | 8 | O | MCLK output |
| | SMCLK | 2 | 2 | 2 | O | SMCLK output |
| | XIN | 7 | 7 | 7 | I | Input terminal for crystal oscillator |
| | XOUT | 8 | 8 | 8 | O | Output terminal for crystal oscillator |
| Debug | SBWTCK | 3 | 3 | 3 | I | Spy-Bi-Wire input clock |
| | SBWTDIO | 4 | 4 | 4 | I/O | Spy-Bi-Wire data input/output |
| | TCK | 18 | 14 | 14 | I | Test clock |
| | TCLK | 16 | 12 | 11 | I | Test clock input |
| | TDI | 16 | 12 | 11 | I | Test data input |
| | TDO | 15 | 11 | 10 | O | Test data output |
| | TMS | 17 | 13 | 13 | I | Test mode select |
| System | TEST | 3 | 3 | 3 | I | Test Mode pin – selected digital I/O on JTAG pins |
| | NMI | 4 | 4 | 4 | I | Nonmaskable interrupt input |
| Power | \bar{RST} | 4 | 4 | 4 | I/O | Reset input, active-low |
| | DVCC | 5 | 5 | 5 | P | Power supply |
| | DVSS | 6 | 6 | 6 | P | Power ground |
| | VREF+ | 15 | 11 | 10 | P | Output of positive reference voltage with ground as reference |

Table 4-2. Signal Descriptions (continued)

| FUNCTION | SIGNAL NAME | PIN NUMBER | | | PIN TYPE | DESCRIPTION |
|----------|------------------------|------------|-----|------|----------|--|
| | | PW20 | RGY | PW16 | | |
| GPIO | P1.1 | 1 | 1 | 1 | I/O | General-purpose I/O |
| | P1.2 | 20 | 16 | 16 | I/O | General-purpose I/O |
| | P1.3 | 19 | 12 | 15 | I/O | General-purpose I/O |
| | P1.4 | 18 | 14 | 14 | I/O | General-purpose I/O ⁽¹⁾ |
| | P1.5 | 17 | 13 | 13 | I/O | General-purpose I/O ⁽¹⁾ |
| | P1.6 | 16 | 12 | 11 | I/O | General-purpose I/O ⁽¹⁾ |
| | P1.7 | 15 | 11 | 10 | I/O | General-purpose I/O ⁽¹⁾ |
| | P2.0 | 14 | 10 | 9 | I/O | General-purpose I/O |
| | P2.1 | 13 | 9 | – | I/O | General-purpose I/O |
| | P2.2 | 12 | – | – | I/O | General-purpose I/O |
| | P2.3 | 11 | – | – | I/O | General-purpose I/O |
| | P2.4 | 10 | – | – | I/O | General-purpose I/O |
| | P2.5 | 9 | – | – | I/O | General-purpose I/O |
| | P2.6 | 8 | 8 | 8 | I/O | General-purpose I/O |
| | P2.7 | 7 | 7 | 7 | I/O | General-purpose I/O |
| I2C | UCB0SCL | 19 | 15 | 15 | I/O | eUSCI_B0 I ² C clock |
| | UCB0SDA | 20 | 16 | 16 | I/O | eUSCI_B0 I ² C data |
| | UCB0SCL ⁽²⁾ | 9 | – | – | I/O | eUSCI_B0 I ² C clock |
| | UCB0SDA ⁽²⁾ | 10 | – | – | I/O | eUSCI_B0 I ² C data |
| SPI | UCA0STE | 18 | 14 | 14 | I/O | eUSCI_A0 SPI slave transmit enable |
| | UCA0CLK | 17 | 13 | 13 | I/O | eUSCI_A0 SPI clock input/output |
| | UCA0SOMI | 16 | 12 | 11 | I/O | eUSCI_A0 SPI slave out/master in |
| | UCA0SIMO | 15 | 11 | 10 | I/O | eUSCI_A0 SPI slave in/master out |
| | UCB0STE | 2 | 2 | 2 | I/O | eUSCI_B0 slave transmit enable |
| | UCB0CLK | 1 | 1 | 1 | I/O | eUSCI_B0 clock input/output |
| | UCB0SIMO | 20 | 16 | 16 | I/O | eUSCI_B0 SPI slave in/master out |
| | UCB0SOMI | 19 | 15 | 15 | I/O | eUSCI_B0 SPI slave out/master in |
| | UCB0STE ⁽²⁾ | 12 | – | – | I/O | eUSCI_B0 slave transmit enable |
| | UCB0CLK ⁽²⁾ | 11 | – | – | I/O | eUSCI_B0 clock input/output |
| UART | UCA0RXD | 16 | 12 | 11 | I | eUSCI_A0 UART receive data |
| | UCA0TXD | 15 | 11 | 10 | O | eUSCI_A0 UART transmit data |
| Timer_B | TB0.1 | 16 | 12 | 11 | I/O | Timer TB0 CCR1 capture: CCI1A input, compare: Out1 outputs |
| | TB0.2 | 15 | 11 | 10 | I/O | Timer TB0 CCR2 capture: CCI2A input, compare: Out2 outputs |
| | TB0CLK | 7 | 7 | 7 | I | Timer clock input TBCLK for TB0 |
| | TB0TRG | 20 | 16 | 16 | I | TB0 external trigger input for TB0OUTH |
| | TB1.1 | 14 | 10 | 9 | I/O | Timer TB1 CCR1 capture: CCI1A input, compare: Out1 outputs |
| | TB1.2 | 13 | 9 | – | I/O | Timer TB1 CCR2 capture: CCI2A input, compare: Out2 outputs |
| | TB1CLK | 12 | – | – | I | Timer clock input TBCLK for TB1 |
| | TB1TRG | 11 | – | – | I | TB1 external trigger input for TB1OUTH |

(1) Because this pin is multiplexed with the JTAG function, TI recommends disabling the pin interrupt function while in JTAG debug to prevent collisions.

(2) This is the remapped functionality controlled by the USCIBRMP bit of the SYSCFG2 register. Only one selected port is valid at any time.

Table 4-2. Signal Descriptions (continued)

| FUNCTION | SIGNAL NAME | PIN NUMBER | | | PIN TYPE | DESCRIPTION |
|----------|------------------|------------|-----|------|----------|---|
| | | PW20 | RGY | PW16 | | |
| VQFN Pad | VQFN Thermal pad | – | Pad | – | | VQFN package exposed thermal pad. TI recommends connection to V _{SS} . |

NOTE

Functions shared with the four JTAG pins cannot be debugged if 4-wire JTAG is used for debug.

4.4 Pin Multiplexing

Pin multiplexing for these devices is controlled by both register settings and operating modes (for example, if the device is in test mode). For details of the settings for each pin and schematics of the multiplexed ports, see [Section 6.12](#).

4.5 Buffer Type

[Table 4-3](#) defines the pin buffer types that are listed in [Table 4-1](#).

Table 4-3. Buffer Type

| BUFFER TYPE (STANDARD) | NOMINAL VOLTAGE | HYSTERESIS | PU OR PD | NOMINAL PU OR PD STRENGTH (μA) | OUTPUT DRIVE STRENGTH (mA) | OTHER CHARACTERISTICS |
|------------------------|-----------------|------------------|--------------|------------------------------------|--------------------------------------|--|
| LVC MOS | 3.0 V | Y ⁽¹⁾ | Programmable | See Section 5.12.4 | See Section 5.12.4.1 | |
| Analog | 3.0 V | N | N | N/A | N/A | See analog modules in Section 5 for details. |
| Power (DVCC) | 3.0 V | N | N | N/A | N/A | SVS enables hysteresis on DVCC. |
| Power (AVCC) | 3.0 V | N | N | N/A | N/A | |

(1) Only for input pins.

4.6 Connection of Unused Pins

[Table 4-4](#) shows the correct termination of unused pins.

Table 4-4. Connection of Unused Pins⁽¹⁾

| PIN | POTENTIAL | COMMENT |
|--------------|-----------|--|
| Px.0 to Px.7 | Open | Set to port function, output direction (PxDIR.n = 1) |
| RST/NMI | DVCC | 47-kΩ pullup or internal pullup selected with 10-nF (or 1.1-nF ⁽²⁾) pulldown |
| TEST | Open | This pin always has an internal pulldown enabled. |
| TRI0- | Open | This pin is a high-impedance output. |

(1) Any unused pin with a secondary function that is shared with general-purpose I/O should follow the Px.0 to Px.7 unused pin connection guidelines.

(2) The pulldown capacitor should not exceed 1.1 nF when using devices with Spy-Bi-Wire interface in Spy-Bi-Wire mode with TI tools like FET interfaces or GANG programmers. TI recommends a 1-nF capacitor to enable high-speed SBW communication.

5 Specifications

5.1 Absolute Maximum Ratings⁽¹⁾

over operating free-air temperature range (unless otherwise noted)

| | MIN | MAX | UNIT |
|--|------|--------------------------------------|------|
| Voltage applied at DVCC pin to V _{SS} | -0.3 | 4.1 | V |
| Voltage applied to any pin ⁽²⁾ | -0.3 | V _{CC} + 0.3 (4.1 V Max) | V |
| Diode current at any device pin | | ±2 | mA |
| Maximum junction temperature, T _J | | 85 | °C |
| Storage temperature, T _{stg} ⁽³⁾ | -40 | 125 | °C |

- (1) Stresses beyond those listed under *Absolute Maximum Ratings* may cause permanent damage to the device. These are stress ratings only, and functional operation of the device at these or any other conditions beyond those indicated under *Recommended Operating Conditions* is not implied. Exposure to absolute-maximum-rated conditions for extended periods may affect device reliability.
- (2) All voltages referenced to V_{SS}.
- (3) Higher temperature may be applied during board soldering according to the current JEDEC J-STD-020 specification with peak reflow temperatures not higher than classified on the device label on the shipping boxes or reels.

5.2 ESD Ratings

| | | VALUE | UNIT |
|--|--|-------|------|
| V _(ESD) Electrostatic discharge | Human-body model (HBM), per ANSI/ESDA/JEDEC JS-001 ⁽¹⁾ | ±1000 | V |
| | Charged-device model (CDM), per JEDEC specification JESD22-C101 ⁽²⁾ | ±250 | |

- (1) JEDEC document JEP155 states that 500-V HBM allows safe manufacturing with a standard ESD control process. Manufacturing with less than 500-V HBM is possible with the necessary precautions. Pins listed as ±1000 V may actually have higher performance.
- (2) JEDEC document JEP157 states that 250-V CDM allows safe manufacturing with a standard ESD control process. Manufacturing with less than 250-V CDM is possible with the necessary precautions. Pins listed as ±250 V may actually have higher performance.

5.3 Recommended Operating Conditions

| | | MIN | NOM | MAX | UNIT |
|---------------------|--|--|-----|-------------------|------|
| V _{CC} | Supply voltage applied at DVCC pin ⁽¹⁾⁽²⁾⁽³⁾⁽⁴⁾ | 1.8 | | 3.6 | V |
| V _{SS} | Supply voltage applied at DVSS pin | | 0 | | V |
| T _A | Operating free-air temperature | -40 | | 85 | °C |
| T _J | Operating junction temperature | -40 | | 85 | °C |
| C _{DVCC} | Recommended capacitor at DVCC ⁽⁵⁾ | 4.7 | 10 | | µF |
| f _{SYSTEM} | Processor frequency (maximum MCLK frequency) ⁽⁴⁾⁽⁶⁾ | No FRAM wait states (NWAITS _x = 0) | | 8 | MHz |
| | | With FRAM wait states (NWAITS _x = 1) ⁽⁷⁾ | 0 | 16 ⁽⁸⁾ | |
| f _{ACLK} | Maximum ACLK frequency | | | 40 | kHz |
| f _{SMCLK} | Maximum SMCLK frequency | | | 16 ⁽⁸⁾ | MHz |

- (1) Supply voltage changes faster than 0.2 V/µs can trigger a BOR reset even within the recommended supply voltage range. Following the data sheet recommendation for capacitor C_{DVCC} limits the slopes accordingly.
- (2) Modules may have a different supply voltage range specification. See the specification of the respective module in this data sheet.
- (3) TI recommends that power to the DVCC pin must not exceed the limits specified in *Recommended Operating Conditions*. Exceeding the specified limits can cause malfunction of the device including erroneous writes to RAM and FRAM.
- (4) The minimum supply voltage is defined by the SVS levels. See the SVS threshold parameters in [Table 5-1](#).
- (5) A capacitor tolerance of ±20% or better is required. A low-ESR ceramic capacitor of 100 nF (minimum) should be placed as close as possible (within a few millimeters) to the respective pin pair.
- (6) Modules may have a different maximum input clock specification. See the specification of the respective module in this data sheet.
- (7) Wait states only occur on actual FRAM accesses (that is, on FRAM cache misses). RAM and peripheral accesses are always executed without wait states.
- (8) If clock sources such as HF crystals or the DCO with frequencies >16 MHz are used, the clock must be divided in the clock system to comply with this operating condition.

5.4 Active Mode Supply Current Into V_{CC} Excluding External Current⁽¹⁾

| PARAMETER | EXECUTION MEMORY | TEST CONDITIONS | FREQUENCY ($f_{MCLK} = f_{SMCLK}$) | | | | | | UNIT |
|-----------------------|------------------------------|-----------------|---|-----|---|-----|---|-----|------|
| | | | 1 MHz 0 WAIT STATES (NWAITS _x = 0) | | 8 MHz 0 WAIT STATES (NWAITS _x = 0) | | 16 MHz 1 WAIT STATE (NWAITS _x = 1) | | |
| | | | TYP | MAX | TYP | MAX | TYP | MAX | |
| $I_{AM, FRAM(0\%)}$ | FRAM 0% cache hit ratio | 3.0 V, 25°C | 474 | | 2639 | | 3156 | μA | |
| | | 3.0 V, 85°C | 516 | | 2919 | | 3205 | | |
| $I_{AM, FRAM(100\%)}$ | FRAM 100% cache hit ratio | 3.0 V, 25°C | 196 | | 585 | | 958 | μA | |
| | | 3.0 V, 85°C | 205 | | 598 | | 974 | | |
| $I_{AM, RAM}^{(2)}$ | RAM | 3.0 V, 25°C | 219 | | 750 | | 1250 | μA | |

(1) All inputs are tied to 0 V or to V_{CC} . Outputs do not source or sink any current. Characterized with program executing typical data processing.

$f_{ACLK} = 32768$ Hz, $f_{MCLK} = f_{SMCLK} = f_{DCO}$ at specified frequency
Program and data entirely reside in FRAM. All execution is from FRAM.

(2) Program and data reside entirely in RAM. All execution is from RAM. No access to FRAM.

5.5 Active Mode Supply Current Per MHz

$V_{CC} = 3.0$ V, $T_A = 25^\circ\text{C}$ (unless otherwise noted)

| PARAMETER | TEST CONDITIONS | TYP | UNIT |
|-------------------|---|-----|--------|
| $dI_{AM,FRAM}/df$ | Active mode current consumption per MHz, execution from FRAM, no wait states ⁽¹⁾ | 126 | μA/MHz |

(1) All peripherals are turned on in default settings.

5.6 Low-Power Mode LPM0 Supply Currents Into V_{CC} Excluding External Current

$V_{CC} = 3.0$ V, $T_A = 25^\circ\text{C}$ (unless otherwise noted)^{(1) (2)}

| PARAMETER | V_{CC} | FREQUENCY (f_{SMCLK}) | | | | | | UNIT |
|------------|----------|---------------------------|-----|-------|-----|--------|-----|------|
| | | 1 MHz | | 8 MHz | | 16 MHz | | |
| | | TYP | MAX | TYP | MAX | TYP | MAX | |
| I_{LPM0} | 2.0 V | 158 | | 307 | | 415 | μA | |
| | 3.0 V | 169 | | 318 | | 427 | | |

(1) All inputs are tied to 0 V or to V_{CC} . Outputs do not source or sink any current.

(2) Current for watchdog timer clocked by SMCLK included.

$f_{ACLK} = 32768$ Hz, $f_{MCLK} = 0$ MHz, f_{SMCLK} at specified frequency.

5.7 Low-Power Mode LPM3 and LPM4 Supply Currents (Into V_{CC}) Excluding External Current

over recommended ranges of supply voltage and operating free-air temperature (unless otherwise noted)⁽¹⁾ (see [Figure 5-1](#))

| PARAMETER | V_{CC} | -40°C | | 25°C | | 85°C | | UNIT |
|--|----------|-------|-----|------|-----|------|------|---------|
| | | TYP | MAX | TYP | MAX | TYP | MAX | |
| $I_{LPM3,XT1}$ Low-power mode 3, includes SVS ^{(2) (3) (4)} | 3.0 V | 1.01 | | 1.16 | | 2.53 | 5.25 | μ A |
| | 2.0 V | 0.99 | | 1.13 | | 2.49 | | |
| $I_{LPM3,VLO}$ Low-power mode 3, VLO, excludes SVS ⁽⁵⁾ | 3.0 V | 0.88 | | 1.02 | | 2.39 | 5.06 | μ A |
| | 2.0 V | 0.86 | | 1.00 | | 2.35 | | |
| $I_{LPM3, RTC}$ Low-power mode 3, RTC, excludes SVS ⁽⁶⁾ | 3.0 V | 0.96 | | 1.11 | | 2.49 | | μ A |
| | 2.0 V | 0.94 | | 1.09 | | 2.45 | | |
| $I_{LPM4, SVS}$ Low-power mode 4, includes SVS ⁽⁷⁾ | 3.0 V | 0.50 | | 0.60 | | 1.93 | | μ A |
| | 2.0 V | 0.48 | | 0.59 | | 1.91 | | |
| I_{LPM4} Low-power mode 4, excludes SVS ⁽⁷⁾ | 3.0 V | 0.34 | | 0.45 | | 1.77 | | μ A |
| | 2.0 V | 0.34 | | 0.44 | | 1.75 | | |
| $I_{LPM4, RTC, VLO}$ Low-power mode 4, RTC is sourced from VLO, excludes SVS ⁽⁸⁾ | 3.0 V | 0.48 | | 0.59 | | 1.91 | | μ A |
| | 2.0 V | 0.48 | | 0.58 | | 1.89 | | |
| $I_{LPM4, RTC, XT1}$ Low-power mode 4, RTC is sourced from XT1, excludes SVS ⁽⁶⁾⁽⁹⁾ | 3.0 V | 0.89 | | 1.04 | | 2.41 | | μ A |
| | 2.0 V | 0.88 | | 1.02 | | 2.38 | | |

- (1) All inputs are tied to 0 V or to V_{CC} . Outputs do not source or sink any current.
- (2) Not applicable for devices with HF crystal oscillator only.
- (3) Characterized with a Seiko Crystal SC-32S crystal with a load capacitance chosen to closely match the required load.
- (4) Low-power mode 3, includes SVS test conditions:
Current for watchdog timer clocked by ACLK and RTC clocked by XT1 included. Current for brownout and SVS included (SVSHE = 1).
CPUOFF = 1, SCG0 = 1 SCG1 = 1, OSCOFF = 0 (LPM3),
 $f_{XT1} = 32768$ Hz, $f_{ACLK} = f_{XT1}$, $f_{MCLK} = f_{SMCLK} = 0$ MHz
- (5) Low-power mode 3, VLO, excludes SVS test conditions:
Current for watchdog timer clocked by VLO included. RTC disabled. Current for brownout included. SVS disabled (SVSHE = 0).
CPUOFF = 1, SCG0 = 1 SCG1 = 1, OSCOFF = 0 (LPM3),
 $f_{XT1} = 32768$ Hz, $f_{MCLK} = f_{SMCLK} = 0$ MHz
- (6) RTC is sourced from external 32768-Hz crystal.
- (7) CPUOFF = 1, SCG0 = 1 SCG1 = 1, OSCOFF = 1 (LPM4), CPU and all clocks are disabled, WDT and RTC disabled
- (8) Low-power mode 4, VLO, excludes SVS test conditions:
Current for RTC clocked by VLO included. Current for brownout included. SVS disabled (SVSHE = 0).
CPUOFF = 1, SCG0 = 1 SCG1 = 1, OSCOFF = 1 (LPM4),
 $f_{XT1} = 0$ Hz, $f_{MCLK} = f_{SMCLK} = 0$ MHz
- (9) Low-power mode 4, XT1, excludes SVS test conditions:
Current for RTC clocked by XT1 included. Current for brownout included. SVS disabled (SVSHE = 0).
CPUOFF = 1, SCG0 = 1 SCG1 = 1, OSCOFF = 1 (LPM4),
 $f_{XT1} = 32768$ Hz, $f_{MCLK} = f_{SMCLK} = 0$ MHz

5.8 Low-Power Mode LPMx.5 Supply Currents (Into V_{CC}) Excluding External Current

over recommended ranges of supply voltage and operating free-air temperature (unless otherwise noted)

| PARAMETER | | V_{CC} | -40°C | | 25°C | | 85°C | | UNIT |
|-------------------|---|----------|-------|-----|-------|-----|-------|-------|---------|
| | | | TYP | MAX | TYP | MAX | TYP | MAX | |
| $I_{LPM3.5, XT1}$ | Low-power mode 3.5, includes SVS ⁽¹⁾ ⁽²⁾ ⁽³⁾ (also see Figure 5-2) | 3.0 V | 0.64 | | 0.71 | | 0.86 | 1.23 | μA |
| | | 2.0 V | 0.61 | | 0.69 | | 0.83 | | |
| $I_{LPM4.5, SVS}$ | Low-power mode 4.5, includes SVS ⁽⁴⁾ (also see Figure 5-3) | 3.0 V | 0.23 | | 0.25 | | 0.30 | 0.45 | μA |
| | | 2.0 V | 0.21 | | 0.24 | | 0.29 | | |
| $I_{LPM4.5}$ | Low-power mode 4.5, excludes SVS ⁽⁵⁾ | 3.0 V | 0.020 | | 0.032 | | 0.071 | 0.120 | μA |
| | | 2.0 V | 0.022 | | 0.034 | | 0.068 | | |

(1) Not applicable for devices with HF crystal oscillator only.

(2) Characterized with a Seiko Crystal SC-32S crystal with a load capacitance chosen to closely match the required load.

(3) Low-power mode 3.5, includes SVS test conditions:

Current for RTC clocked by XT1 included. Current for brownout and SVS included (SVSHE = 1). Core regulator disabled.

PMMREGOFF = 1, CPUOFF = 1, SCG0 = 1 SCG1 = 1, OSCOFF = 1 (LPMx.5),

$f_{XT1} = 32768$ Hz, $f_{ACLK} = f_{XT1}$, $f_{MCLK} = f_{SMCLK} = 0$ MHz

(4) Low-power mode 4.5, includes SVS test conditions:

Current for brownout and SVS included (SVSHE = 1). Core regulator disabled.

PMMREGOFF = 1, CPUOFF = 1, SCG0 = 1 SCG1 = 1, OSCOFF = 1 (LPMx.5),

$f_{XT1} = 0$ Hz, $f_{ACLK} = f_{MCLK} = f_{SMCLK} = 0$ MHz

(5) Low-power mode 4.5, excludes SVS test conditions:

Current for brownout included. SVS disabled (SVSHE = 0). Core regulator disabled.

PMMREGOFF = 1, CPUOFF = 1, SCG0 = 1 SCG1 = 1, OSCOFF = 1 (LPMx.5),

$f_{XT1} = 0$ Hz, $f_{ACLK} = f_{MCLK} = f_{SMCLK} = 0$ MHz

5.9 Production Distribution of LPM Supply Currents

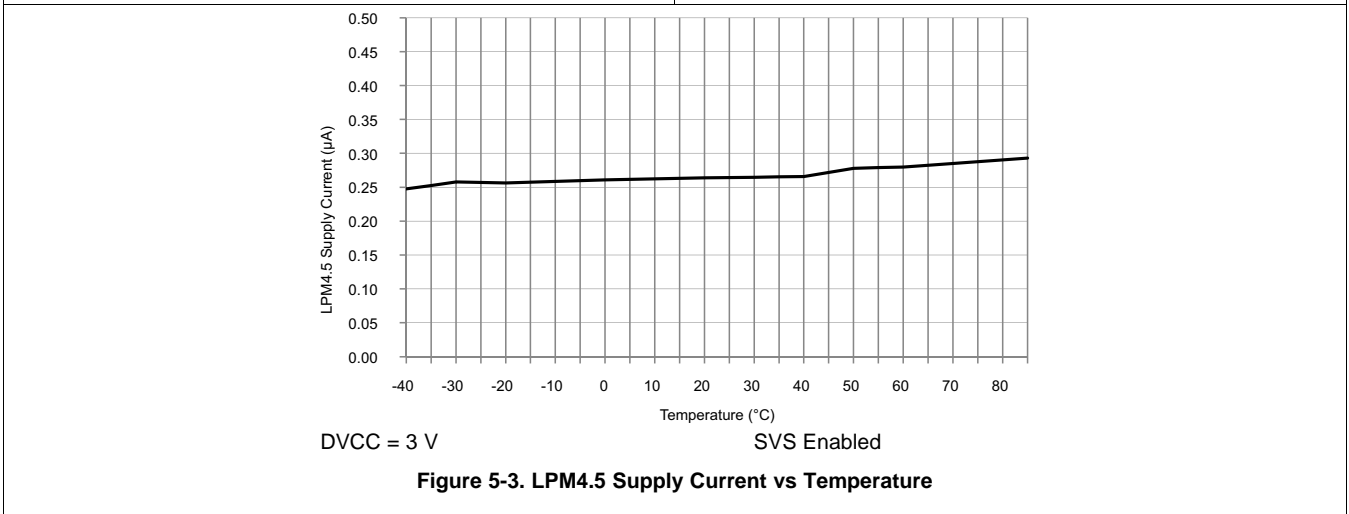
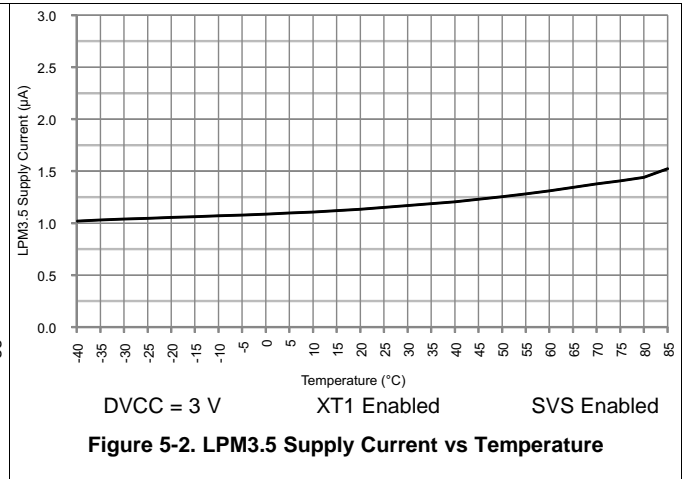
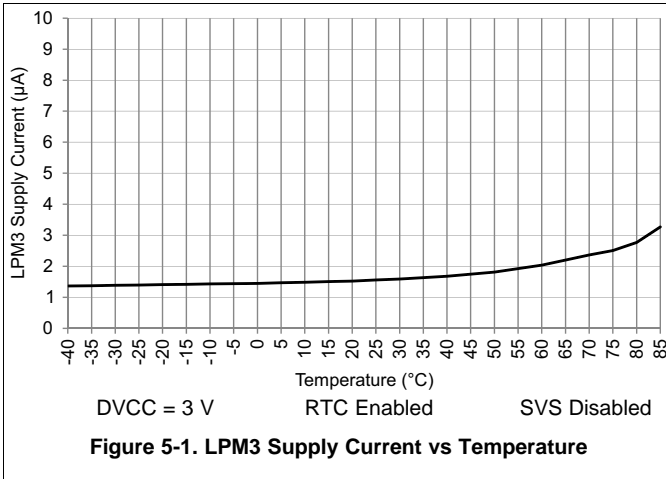

5.10 Typical Characteristics – Current Consumption Per Module

| MODULE | TEST CONDITIONS | REFERENCE CLOCK | TYP | UNIT |
|---------|----------------------------------|--------------------|-----|--------|
| Timer_B | SMCLK = 8 MHz, MC = 10b | Module input clock | 5 | μA/MHz |
| eUSCI_A | UART mode | Module input clock | 7 | μA/MHz |
| eUSCI_A | SPI mode | Module input clock | 5 | μA/MHz |
| eUSCI_B | SPI mode | Module input clock | 5 | μA/MHz |
| eUSCI_B | I ² C mode, 100 kbaud | Module input clock | 5 | μA/MHz |
| RTC | | 32 kHz | 85 | nA |
| CRC | From start to end of operation | MCLK | 8.5 | μA/MHz |

5.11 Thermal Resistance Characteristics

| | | | VALUE | UNIT |
|-----------------|--|---------------------|-------|------|
| θ _{JA} | Junction-to-ambient thermal resistance, still air ⁽¹⁾ | VQFN 16 pin (RGY) | 41.8 | °C/W |
| | | TSSOP 20 pin (PW20) | 92.6 | |
| | | TSSOP 16 pin (PW16) | 104.1 | |
| θ _{JC} | Junction-to-case (top) thermal resistance ⁽²⁾ | VQFN 16 pin (RGY) | 49.1 | °C/W |
| | | TSSOP 20 pin (PW20) | 26.1 | |
| | | TSSOP 16 pin (PW16) | 38.5 | |
| θ _{JB} | Junction-to-board thermal resistance ⁽³⁾ | VQFN 16 pin (RGY) | 18.5 | °C/W |
| | | TSSOP 20 pin (PW20) | 45.0 | |
| | | TSSOP 16 pin (PW16) | 49.1 | |

- (1) The junction-to-ambient thermal resistance under natural convection is obtained in a simulation on a JEDEC-standard, High-K board, as specified in JESD51-7, in an environment described in JESD51-2a.
- (2) The junction-to-case (top) thermal resistance is obtained by simulating a cold plate test on the package top. No specific JEDEC-standard test exists, but a close description can be found in the ANSI SEMI standard G30-88.
- (3) The junction-to-board thermal resistance is obtained by simulating in an environment with a ring cold plate fixture to control the PCB temperature, as described in JESD51-8.

5.12 Timing and Switching Characteristics

5.12.1 Power Supply Sequencing

Table 5-1 lists the characteristics of the SVS and BOR.

Table 5-1. PMM, SVS and BOR

over recommended ranges of supply voltage and operating free-air temperature (unless otherwise noted) (see Figure 5-4)

| PARAMETER | | TEST CONDITIONS | MIN | TYP | MAX | UNIT |
|---------------------|---|-------------------------|------|------|------|---------------|
| $V_{BOR, safe}$ | Safe BOR power-down level ⁽¹⁾ | | 0.1 | | | V |
| $t_{BOR, safe}$ | Safe BOR reset delay ⁽²⁾ | | 10 | | | ms |
| $I_{SVSH, AM}$ | SVS _H current consumption, active mode | $V_{CC} = 3.6\text{ V}$ | | | 1.5 | μA |
| $I_{SVSH, LPM}$ | SVS _H current consumption, low-power modes | $V_{CC} = 3.6\text{ V}$ | | 240 | | nA |
| V_{SVSH-} | SVS _H power-down level ⁽³⁾ | | 1.71 | 1.80 | 1.87 | V |
| V_{SVSH+} | SVS _H power-up level ⁽³⁾ | | 1.76 | 1.88 | 1.99 | V |
| V_{SVSH_hys} | SVS _H hysteresis | | | 80 | | mV |
| $t_{PD, SVSH, AM}$ | SVS _H propagation delay, active mode | | | | 10 | μs |
| $t_{PD, SVSH, LPM}$ | SVS _H propagation delay, low-power modes | | | | 100 | μs |

- (1) A safe BOR is correctly generated only if DVCC drops below this voltage before it rises.
- (2) When an BOR occurs, a safe BOR is correctly generated only if DVCC is kept low longer than this period before it reaches V_{SVSH+} .
- (3) For additional information, see the [Dynamic Voltage Scaling Power Solution for MSP430 Devices With Single-Channel LDO Reference Design](#).

Figure 5-4 shows the reset conditions.

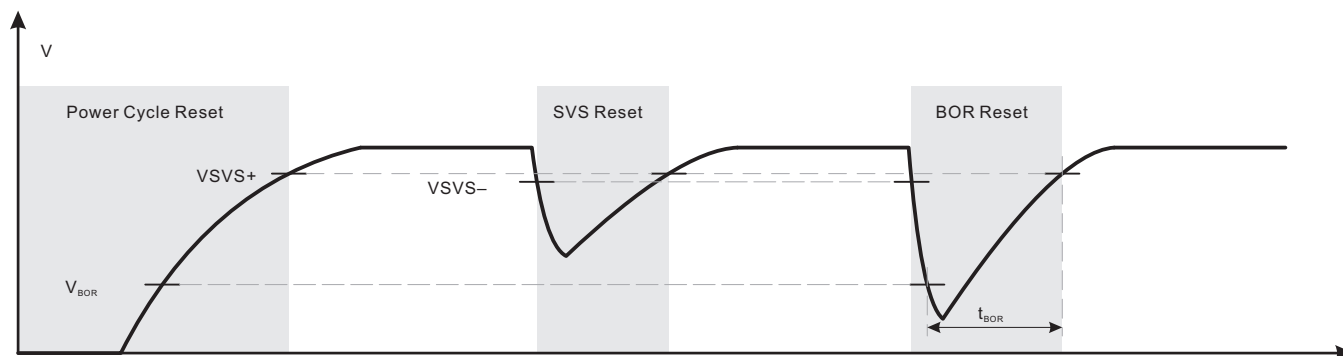

Figure 5-4. Power Cycle, SVS, and BOR Reset Conditions

5.12.2 Reset Timing

Table 5-2 lists the wake-up times from low-power modes and reset.

Table 5-2. Wake-up Times From Low-Power Modes and Reset

over recommended ranges of supply voltage and operating free-air temperature (unless otherwise noted)

| PARAMETER | TEST CONDITIONS | V _{CC} | MIN | TYP | MAX | UNIT |
|-----------------------------|---|-----------------|-----|-----|---------------------------------|------|
| t _{WAKE-UP FRAM} | (Additional) wake-up time to activate the FRAM in AM if previously disabled through the FRAM controller or from a LPM if immediate activation is selected for wakeup ⁽¹⁾ | 3 V | | 10 | | μs |
| t _{WAKE-UP LPM0} | Wake-up time from LPM0 to active mode ⁽¹⁾ | 3 V | | | 200 + 2.5 / f _{DCO} | ns |
| t _{WAKE-UP LPM3} | Wake-up time from LPM3 to active mode ⁽¹⁾ | 3 V | | 10 | | μs |
| t _{WAKE-UP LPM4} | Wake-up time from LPM4 to active mode ⁽²⁾ | 3 V | | 10 | | μs |
| t _{WAKE-UP LPM3.5} | Wake-up time from LPM3.5 to active mode ⁽²⁾ | 3 V | | 350 | | μs |
| t _{WAKE-UP LPM4.5} | Wake-up time from LPM4.5 to active mode ⁽²⁾ | SVSHE = 1 | 3 V | 350 | | μs |
| | | SVSHE = 0 | 3 V | 1 | | ms |
| t _{WAKE-UP-RESET} | Wake-up time from $\overline{\text{RST}}$ or BOR event to active mode ⁽²⁾ | 3 V | | 1 | | ms |
| t _{RESET} | Pulse duration required at $\overline{\text{RST}}$ /NMI pin to accept a reset | | | 2 | | μs |

- (1) The wake-up time is measured from the edge of an external wake-up signal (for example, port interrupt or wake-up event) to the first externally observable MCLK clock edge.
- (2) The wake-up time is measured from the edge of an external wake-up signal (for example, port interrupt or wake-up event) until the first instruction of the user program is executed.

5.12.3 Clock Specifications

Table 5-3 lists the characteristics of the XT1 crystal oscillator (low frequency).

Table 5-3. XT1 Crystal Oscillator (Low Frequency)

over recommended ranges of supply voltage and operating free-air temperature (unless otherwise noted)⁽¹⁾⁽²⁾

| PARAMETER | | TEST CONDITIONS | V _{CC} | MIN | TYP | MAX | UNIT |
|--------------------------|--|--|-----------------|-----|------------------|------|------|
| f _{XT1, LF} | XT1 oscillator crystal, low frequency | LFXTBYPASS = 0 | | | 32768 | | Hz |
| DC _{XT1, LF} | XT1 oscillator LF duty cycle | Measured at MCLK, f _{LFXT} = 32768 Hz | | 30% | | 70% | |
| f _{XT1, SW} | XT1 oscillator logic-level square-wave input frequency | LFXTBYPASS = 1 ^{(3) (4)} | | | 32768 | | Hz |
| DC _{XT1, SW} | LFXT oscillator logic-level square-wave input duty cycle | LFXTBYPASS = 1 | | 40% | | 60% | |
| OA _{LFXT} | Oscillation allowance for LF crystals ⁽⁵⁾ | LFXTBYPASS = 0, LFXTDRIVE = {3}, f _{LFXT} = 32768 Hz, C _{L,eff} = 12.5 pF | | | 200 | | kΩ |
| C _{L,eff} | Integrated effective load capacitance ⁽⁶⁾ | | | | ⁽⁷⁾ 1 | | pF |
| t _{START, LFXT} | Start-up time ⁽⁸⁾ | f _{OSC} = 32768 Hz LFXTBYPASS = 0, LFXTDRIVE = {3}, T _A = 25°C, C _{L,eff} = 12.5 pF | | | 1000 | | ms |
| f _{Fault, LFXT} | Oscillator fault frequency ⁽⁹⁾ | XTS = 0 ⁽¹⁰⁾ | | 0 | | 3500 | Hz |

- (1) To improve EMI on the LFXT oscillator, observe the following guidelines.
 - Keep the trace between the device and the crystal as short as possible.
 - Design a good ground plane around the oscillator pins.
 - Prevent crosstalk from other clock or data lines into oscillator pins XIN and XOUT.
 - Avoid running PCB traces under or adjacent to the XIN and XOUT pins.
 - Use assembly materials and processes that avoid any parasitic load on the oscillator XIN and XOUT pins.
 - If conformal coating is used, make sure that it does not induce capacitive or resistive leakage between the oscillator pins.
- (2) See [MSP430 32-kHz Crystal Oscillators](#) for details on crystal section, layout, and testing.
- (3) When LFXTBYPASS is set, LFXT circuits are automatically powered down. Input signal is a digital square wave with parametrics defined in the Schmitt-trigger inputs section of this data sheet. Duty cycle requirements are defined by DC_{LFXT, SW}.
- (4) Maximum frequency of operation of the entire device cannot be exceeded.
- (5) Oscillation allowance is based on a safety factor of 5 for recommended crystals. The oscillation allowance is a function of the LFXTDRIVE settings and the effective load. In general, comparable oscillator allowance can be achieved based on the following guidelines, but should be evaluated based on the actual crystal selected for the application:
 - For LFXTDRIVE = {0}, C_{L,eff} = 3.7 pF.
 - For LFXTDRIVE = {1}, 6 pF ≤ C_{L,eff} ≤ 9 pF.
 - For LFXTDRIVE = {2}, 6 pF ≤ C_{L,eff} ≤ 10 pF.
 - For LFXTDRIVE = {3}, 6 pF ≤ C_{L,eff} ≤ 12 pF.
- (6) Includes parasitic bond and package capacitance (approximately 2 pF per pin).
- (7) Requires external capacitors at both terminals to meet the effective load capacitance specified by crystal manufacturers. Recommended effective load capacitance values supported are 3.7 pF, 6 pF, 9 pF, and 12.5 pF. Maximum shunt capacitance of 1.6 pF. The PCB adds additional capacitance, so it must also be considered in the overall capacitance. Verify that the recommended effective load capacitance of the selected crystal is met.
- (8) Includes start-up counter of 1024 clock cycles.
- (9) Frequencies above the MAX specification do not set the fault flag. Frequencies in between the MIN and MAX specification may set the flag. A static condition or stuck at fault condition sets the flag.
- (10) Measured with logic-level input frequency but also applies to operation with crystals.

Table 5-4 lists the characteristics of the XT1 crystal oscillator (high frequency).

Table 5-4. XT1 Crystal Oscillator (High Frequency)

over recommended ranges of supply voltage and operating free-air temperature (unless otherwise noted)⁽¹⁾

| PARAMETER | | TEST CONDITIONS | V _{CC} | MIN | TYP | MAX | UNIT |
|-------------------------|--|--|-----------------|------|-----|-----|------|
| f _{HFXT} | HFXT oscillator crystal frequency, crystal mode | XT1BYPASS = 0, XTS = 1, XT1HFFREQ = 00 | | 1 | | 4 | MHz |
| | | XT1BYPASS = 0, XTS = 1, XT1HFFREQ = 01 | | 4.01 | | 6 | |
| | | XT1BYPASS = 0, XTS = 1, XT1HFFREQ = 10 | | 6.01 | | 16 | |
| f _{HFXT,SW} | HFXT oscillator logic-level square-wave input frequency, bypass mode | XT1BYPASS = 1, XTS = 1 ⁽²⁾ ⁽³⁾ | | 1 | | 16 | MHz |
| DC _{HFXT} | HFXT oscillator duty cycle | Measured at ACLK, f _{HFXT,HF} = 4 MHz ⁽⁴⁾ | | 40% | | 60% | |
| DC _{HFXT,SW} | HFXT oscillator logic-level square-wave input duty cycle | XT1BYPASS = 1 | | 40% | | 60% | |
| OA _{HFXT} | Oscillation allowance for HFXT crystals ⁽⁵⁾ | XT1BYPASS = 0, XT1HFSEL = 1, f _{HFXT,HF} = 16 MHz, C _{L,eff} = 18 pF | | | 2.4 | | kΩ |
| t _{START,HFXT} | Start-up time ⁽⁶⁾ | f _{OSC} = 4 MHz, XTS = 1 ⁽⁴⁾ , XT1BYPASS = 0, XT1HFFREQ = 00, XT1DRIVE = 3, T _A = 25°C, C _{L,eff} = 18 pF | | | 1.6 | | ms |
| | | f _{OSC} = 16 MHz, XTS = 1 ⁽⁴⁾ , XT1BYPASS = 0, XT1HFFREQ = 00, XT1DRIVE = 3, T _A = 25°C, C _{L,eff} = 18 pF | | | 1.1 | | |
| C _{L,eff} | Integrated effective load capacitance ⁽⁷⁾ ⁽⁸⁾ | | | | 1 | | pF |
| f _{Fault,HFXT} | Oscillator fault frequency ⁽⁹⁾ ⁽¹⁰⁾ | | | 0 | | 800 | kHz |

- (1) To improve EMI on the HFXT oscillator, the following guidelines should be observed.
 - Keep the trace between the device and the crystal as short as possible.
 - Design a good ground plane around the oscillator pins.
 - Prevent crosstalk from other clock or data lines into oscillator pins XIN and XOUT.
 - Avoid running PCB traces under or adjacent to the XIN and XOUT pins.
 - Use assembly materials and processes that avoid any parasitic load on the oscillator XIN and XOUT pins.
 - If conformal coating is used, make sure that it does not induce capacitive or resistive leakage between the oscillator pins.
- (2) When XT1BYPASS is set, HFXT circuits are automatically powered down. Input signal is a digital square wave with parametrics defined in the Schmitt-trigger Inputs section of this datasheet. Duty cycle requirements are defined by DC_{HFXT, SW}.
- (3) Maximum frequency of operation of the entire device cannot be exceeded.
- (4) 4-MHz crystal used for lab characterization: Abracon HC49/U AB-4.000MHZ-B2
16-MHz crystal used for lab characterization: Abracon HC49/U AB-16.000MHZ-B2
- (5) Oscillation allowance is based on a safety factor of 5 for recommended crystals.
- (6) Includes start-up counter of 4096 clock cycles.
- (7) Includes parasitic bond and package capacitance (approximately 2 pF per pin).
Because the PCB adds additional capacitance, TI recommends verifying the correct load by measuring the oscillator frequency through MCLK or SMCLK. For a correct setup, the effective load capacitance should always match the specification of the used crystal.
- (8) Requires external capacitors at both terminals. Values are specified by crystal manufacturers. Recommended values supported are 14 pF, 16 pF, and 18 pF. Maximum shunt capacitance of 7 pF.
- (9) Frequencies above the MAX specification do not set the fault flag. Frequencies between the MIN and MAX might set the flag. A static condition or stuck at fault condition sets the flag.
- (10) Measured with logic-level input frequency but also applies to operation with crystals.

Table 5-5 lists the characteristics of the DCO FLL.

Table 5-5. DCO FLL

over recommended operating free-air temperature (unless otherwise noted)

| PARAMETER | | TEST CONDITIONS | V _{CC} | MIN | TYP | MAX | UNIT |
|------------------------|---|--|-----------------|-------|--------|------|------|
| f _{DCO, FLL} | FLL lock frequency, 16 MHz, 25°C | Measured at MCLK, internal trimmed REFO as reference | 3.0 V | -1.0% | | 1.0% | |
| | FLL lock frequency, 16 MHz, -40°C to 85°C | | | -2.0% | | 2.0% | |
| | FLL lock frequency, 16 MHz, -40°C to 85°C | Measured at MCLK, XT1 crystal as reference | | -0.5% | | 0.5% | |
| f _{DUTY} | Duty cycle | Measured at MCLK, XT1 crystal as reference | 3.0 V | 40% | 50% | 60% | |
| Jitter _{cc} | Cycle-to-cycle jitter, 16 MHz | Measured at MCLK, XT1 crystal as reference | 3.0 V | | 0.25% | | |
| Jitter _{long} | Long-term jitter, 16 MHz | Measured at MCLK, XT1 crystal as reference | 3.0 V | | 0.022% | | |
| t _{FLL, lock} | FLL lock time, 16 MHz | Measured at MCLK, XT1 crystal as reference | 3.0 V | | 200 | | ms |

Table 5-6 lists the characteristics of the DCO frequency.

Table 5-6. DCO Frequency

over recommended operating free-air temperature (unless otherwise noted) (see Figure 5-5)

| PARAMETER | | TEST CONDITIONS | MIN | TYP | MAX | UNIT |
|--------------------------|-----------------------|---|-----|------|-----|------|
| f _{DCO, 16 MHz} | DCO frequency, 16 MHz | DCORSEL = 101b, DISMOD = 1b, DCOFTRIM = 000b, DCO = 0 | | 7.8 | | MHz |
| | | DCORSEL = 101b, DISMOD = 1b, DCOFTRIM = 000b, DCO = 511 | | 12.5 | | |
| | | DCORSEL = 101b, DISMOD = 1b, DCOFTRIM = 111b, DCO = 0 | | 18 | | |
| | | DCORSEL = 101b, DISMOD = 1b, DCOFTRIM = 111b, DCO = 511 | | 30 | | |
| f _{DCO, 12 MHz} | DCO frequency, 12 MHz | DCORSEL = 100b, DISMOD = 1b, DCOFTRIM = 000b, DCO = 0 | | 6 | | MHz |
| | | DCORSEL = 100b, DISMOD = 1b, DCOFTRIM = 000b, DCO = 511 | | 9.5 | | |
| | | DCORSEL = 100b, DISMOD = 1b, DCOFTRIM = 111b, DCO = 0 | | 13.5 | | |
| | | DCORSEL = 100b, DISMOD = 1b, DCOFTRIM = 111b, DCO = 511 | | 22 | | |
| f _{DCO, 8 MHz} | DCO frequency, 8 MHz | DCORSEL = 011b, DISMOD = 1b, DCOFTRIM = 000b, DCO = 0 | | 3.8 | | MHz |
| | | DCORSEL = 011b, DISMOD = 1b, DCOFTRIM = 000b, DCO = 511 | | 6.5 | | |
| | | DCORSEL = 011b, DISMOD = 1b, DCOFTRIM = 111b, DCO = 0 | | 9.5 | | |
| | | DCORSEL = 011b, DISMOD = 1b, DCOFTRIM = 111b, DCO = 511 | | 16 | | |
| f _{DCO, 4 MHz} | DCO frequency, 4 MHz | DCORSEL = 010b, DISMOD = 1b, DCOFTRIM = 000b, DCO = 0 | | 2 | | MHz |
| | | DCORSEL = 010b, DISMOD = 1b, DCOFTRIM = 000b, DCO = 511 | | 3.2 | | |
| | | DCORSEL = 010b, DISMOD = 1b, DCOFTRIM = 111b, DCO = 0 | | 4.8 | | |
| | | DCORSEL = 010b, DISMOD = 1b, DCOFTRIM = 111b, DCO = 511 | | 8 | | |

Table 5-6. DCO Frequency (continued)

over recommended operating free-air temperature (unless otherwise noted) (see Figure 5-5)

| PARAMETER | TEST CONDITIONS | MIN | TYP | MAX | UNIT |
|--|---|-----|------|-----|------|
| f _{DCO, 2 MHz} DCO frequency, 2 MHz | DCORSEL = 001b, DISMOD = 1b, DCOFTRIM = 000b, DCO = 0 | | 1 | | MHz |
| | DCORSEL = 001b, DISMOD = 1b, DCOFTRIM = 000b, DCO = 511 | | 1.7 | | |
| | DCORSEL = 001b, DISMOD = 1b, DCOFTRIM = 111b, DCO = 0 | | 2.5 | | |
| | DCORSEL = 001b, DISMOD = 1b, DCOFTRIM = 111b, DCO = 511 | | 4.2 | | |
| f _{DCO, 1 MHz} DCO frequency, 1 MHz | DCORSEL = 000b, DISMOD = 1b, DCOFTRIM = 000b, DCO = 0 | | 0.5 | | MHz |
| | DCORSEL = 000b, DISMOD = 1b, DCOFTRIM = 000b, DCO = 511 | | 0.85 | | |
| | DCORSEL = 000b, DISMOD = 1b, DCOFTRIM = 111b, DCO = 0 | | 1.2 | | |
| | DCORSEL = 000b, DISMOD = 1b, DCOFTRIM = 111b, DCO = 511 | | 2.1 | | |

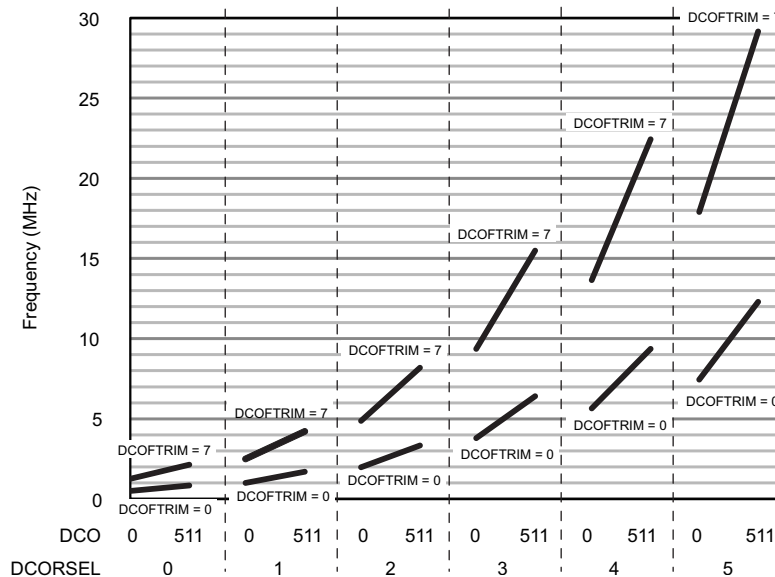

Figure 5-5. Typical DCO Frequency

Table 5-7 lists the characteristics of the REFO.

Table 5-7. REFO

over recommended operating free-air temperature (unless otherwise noted)

| PARAMETER | TEST CONDITIONS | V _{CC} | MIN | TYP | MAX | UNIT |
|--------------------------------------|-------------------------------------|---|----------------|-------|-------|------|
| I _{REFO} | REFO oscillator current consumption | T _A = 25°C | 3.0 V | 15 | | μA |
| f _{REFO} | REFO calibrated frequency | Measured at MCLK | 3.0 V | 32768 | | Hz |
| | REFO absolute calibrated tolerance | T _A = -40°C to 85°C | 1.8 V to 3.6 V | -3.5% | +3.5% | |
| df _{REFO} /dT | REFO frequency temperature drift | Measured at MCLK ⁽¹⁾ | 3.0 V | 0.01 | | %/°C |
| df _{REFO} /dV _{CC} | REFO frequency supply voltage drift | Measured at MCLK at 25°C ⁽²⁾ | 1.8 V to 3.6 V | 1 | | %/V |
| f _{DC} | REFO duty cycle | Measured at MCLK | 1.8V to 3.6 V | 40% | 50% | 60% |
| t _{START} | REFO start-up time | 40% to 60% duty cycle | | 50 | | μs |

(1) Calculated using the box method: (MAX(-40°C to 85°C) – MIN(-40°C to 85°C)) / MIN(-40°C to 85°C) / (85°C – (-40°C))

(2) Calculated using the box method: (MAX(1.8 V to 3.6 V) – MIN(1.8 V to 3.6 V)) / MIN(1.8 V to 3.6 V) / (3.6 V – 1.8 V)

Table 5-8 lists the characteristics of the internal very-low-power low-frequency oscillator (VLO).

Table 5-8. Internal Very-Low-Power Low-Frequency Oscillator (VLO)

over recommended ranges of supply voltage and operating free-air temperature (unless otherwise noted)

| PARAMETER | | TEST CONDITIONS | V _{CC} | MIN | TYP | MAX | UNIT |
|-------------------------------------|------------------------------------|---------------------------------|-----------------|-----|-----|-----|------|
| f _{VLO} | VLO frequency | Measured at MCLK | 3.0 V | | 10 | | kHz |
| df _{VLO} /dT | VLO frequency temperature drift | Measured at MCLK ⁽¹⁾ | 3.0 V | | 0.5 | | %/°C |
| df _{VLO} /dV _{CC} | VLO frequency supply voltage drift | Measured at MCLK ⁽²⁾ | 1.8 V to 3.6 V | | 4 | | %/V |
| f _{VLO,DC} | Duty cycle | Measured at MCLK | 3.0 V | | 50% | | |

(1) Calculated using the box method: (MAX(−40°C to 85°C) – MIN(−40°C to 85°C)) / MIN(−40°C to 85°C) / (85°C – (−40°C))

(2) Calculated using the box method: (MAX(1.8 V to 3.6 V) – MIN(1.8 V to 3.6 V)) / MIN(1.8 V to 3.6 V) / (3.6 V – 1.8 V)

NOTE

The VLO clock frequency is reduced by 15% (typical) when the device switches from active mode or LPM0 to LPM3 or LPM4, because the reference changes. This lower frequency is not a violation of the VLO specifications (see Table 5-8).

Table 5-9 lists the characteristics of the module oscillator (MODOSC).

Table 5-9. Module Oscillator (MODOSC)

over recommended ranges of supply voltage and operating free-air temperature (unless otherwise noted)

| PARAMETER | | V _{CC} | MIN | TYP | MAX | UNIT |
|---------------------------------------|---------------------------------------|-----------------|-----|-------|-----|------|
| f _{MODOSC} | MODOSC frequency | 3.0 V | 3.8 | 4.8 | 5.8 | MHz |
| f _{MODOSC} /dT | MODOSC frequency temperature drift | 3.0 V | | 0.102 | | %/°C |
| f _{MODOSC} /dV _{CC} | MODOSC frequency supply voltage drift | 1.8 V to 3.6 V | | 1.02 | | %/V |
| f _{MODOSC,DC} | Duty cycle | 3.0 V | 40% | 50% | 60% | |

5.12.4 Digital I/Os

Table 5-10 lists the characteristics of the digital inputs.

Table 5-10. Digital Inputs

over recommended ranges of supply voltage and operating free-air temperature (unless otherwise noted)

| PARAMETER | | TEST CONDITIONS | V _{CC} | MIN | TYP | MAX | UNIT |
|------------------------|--|--|-----------------|------|-----|------|------|
| V _{IT+} | Positive-going input threshold voltage | | 2 V | 0.90 | | 1.50 | V |
| | | | 3 V | 1.35 | | 2.25 | |
| V _{IT-} | Negative-going input threshold voltage | | 2 V | 0.50 | | 1.10 | V |
| | | | 3 V | 0.75 | | 1.65 | |
| V _{hys} | Input voltage hysteresis (V _{IT+} – V _{IT-}) | | 2 V | 0.3 | | 0.8 | V |
| | | | 3 V | 0.4 | | 1.2 | |
| R _{Pull} | Pullup or pulldown resistor | For pullup: V _{IN} = V _{SS} For pulldown: V _{IN} = V _{CC} | | 20 | 35 | 50 | kΩ |
| C _{I,dig} | Input capacitance, digital only port pins | V _{IN} = V _{SS} or V _{CC} | | | 3 | | pF |
| C _{I,ana} | Input capacitance, port pins with shared analog functions | V _{IN} = V _{SS} or V _{CC} | | | 5 | | pF |
| I _{lkg(Px.y)} | High-impedance leakage current ⁽¹⁾⁽²⁾ | | 2 V, 3 V | -20 | | +20 | nA |
| t _(int) | External interrupt timing (external trigger pulse duration to set interrupt flag) ⁽³⁾ | Ports with interrupt capability (see block diagram and terminal function descriptions) | 2 V, 3 V | 50 | | | ns |

(1) The leakage current is measured with V_{SS} or V_{CC} applied to the corresponding pins, unless otherwise noted.

(2) The leakage of the digital port pins is measured individually. The port pin is selected for input and the pullup or pulldown resistor is disabled.

(3) An external signal sets the interrupt flag every time the minimum interrupt pulse duration t_(int) is met. The interrupt flag may be set by trigger signals shorter than t_(int).

Table 5-11 lists the characteristics of the digital outputs. Also see Figure 5-6 through Figure 5-9.

Table 5-11. Digital Outputs

over recommended ranges of supply voltage and operating free-air temperature (unless otherwise noted)

| PARAMETER | | TEST CONDITIONS | V _{CC} | MIN | TYP | MAX | UNIT |
|-----------------------|---|---|-----------------|-----|-----|------|------|
| V _{OH} | High-level output voltage | I _(OHmax) = -3 mA ⁽¹⁾ | 2.0 V | 1.4 | | 2.0 | V |
| | | I _(OHmax) = -5 mA ⁽¹⁾ | 3.0 V | 2.4 | | 3.0 | |
| V _{OL} | Low-level output voltage | I _(OLmax) = 3 mA ⁽¹⁾ | 2.0 V | 0.0 | | 0.60 | V |
| | | I _(OLmax) = 5 mA ⁽¹⁾ | 3.0 V | 0.0 | | 0.60 | |
| f _{Port_CLK} | Clock output frequency | C _L = 20 pF ⁽²⁾ | 2.0 V | 16 | | | MHz |
| | | | 3.0 V | 16 | | | |
| t _{rise,dig} | Port output rise time, digital only port pins | C _L = 20 pF | 2.0 V | | 10 | | ns |
| | | | 3.0 V | | 7 | | |
| t _{fall,dig} | Port output fall time, digital only port pins | C _L = 20 pF | 2.0 V | | 10 | | ns |
| | | | 3.0 V | | 5 | | |

(1) The maximum total current, I_(OHmax) and I_(OLmax), for all outputs combined should not exceed ±48 mA to hold the maximum voltage drop specified.

(2) The port can output frequencies at least up to the specified limit and might support higher frequencies.

5.12.4.1 Digital I/O Typical Characteristics

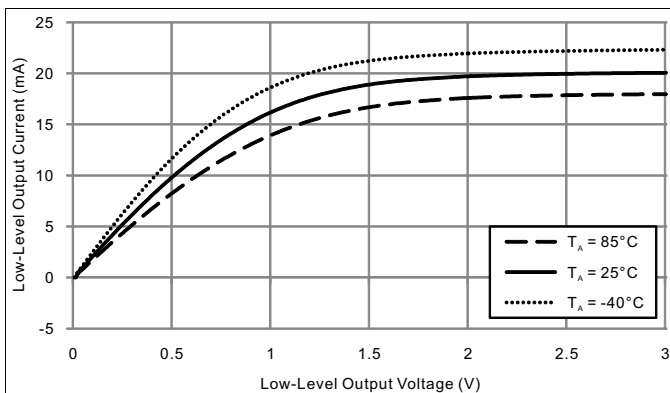

Figure 5-6. Typical Low-Level Output Current vs Low-Level Output Voltage (DVCC = 3 V)

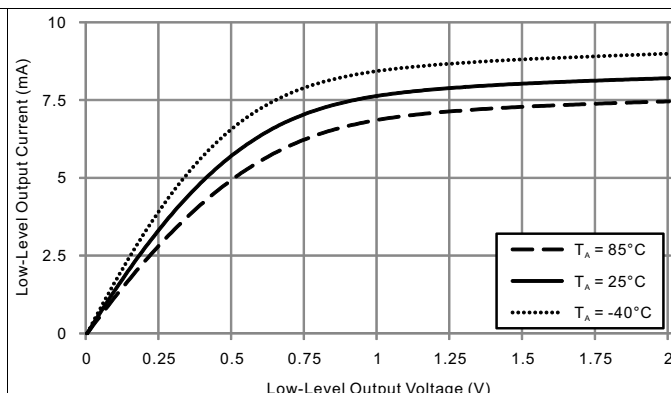

Figure 5-7. Typical Low-Level Output Current vs Low-Level Output Voltage (DVCC = 2 V)

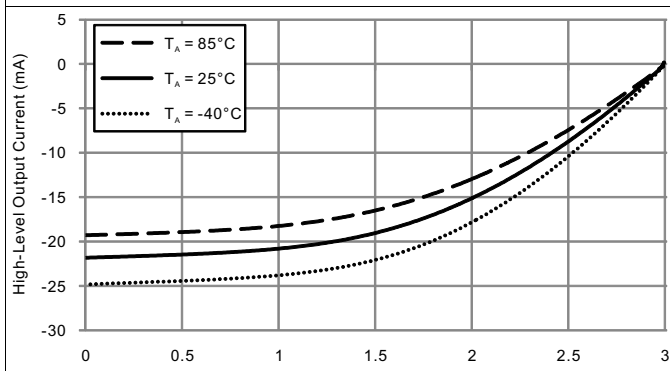

Figure 5-8. Typical High-Level Output Current vs High-Level Output Voltage (DVCC = 3 V)

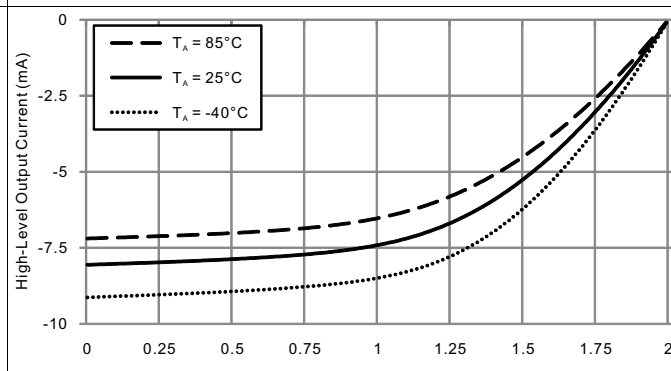

Figure 5-9. Typical High-Level Output Current vs High-Level Output Voltage (DVCC = 2 V)

5.12.5 VREF+ Built-in Reference

Table 5-12 lists the characteristics of the VREF+.

Table 5-12. VREF+

over recommended ranges of supply voltage and operating free-air temperature (unless otherwise noted)

| PARAMETER | | TEST CONDITIONS | V _{CC} | MIN | TYP | MAX | UNIT |
|--------------------|---|---|-----------------|------|------|------|-------|
| V _{REF+} | Positive built-in reference voltage | EXTREFEN = 1 with 1-mA load current to ground | 2.0 V, 3.0 V | 1.15 | 1.19 | 1.23 | V |
| T _{CREF+} | Temperature coefficient of built-in reference voltage | EXTREFEN = 1 with 1-mA load current | | | 30 | | μV/°C |

5.12.6 Timer_B

Table 5-13 lists the characteristics of the Timer_B clock frequency.

Table 5-13. Timer_B

over recommended ranges of supply voltage and operating free-air temperature (unless otherwise noted)

| PARAMETER | | TEST CONDITIONS | V _{CC} | MIN | MAX | UNIT |
|---------------------|-------------------------------|---|-----------------|-----|-----|------|
| f _{TB} | Timer_B input clock frequency | Internal: SMCLK or ACLK, External: TBCLK, Duty cycle = 50% ±10% | 2.0 V, 3.0 V | | 16 | MHz |
| t _{TB,cap} | Timer_B capture timing | All capture inputs, minimum pulse duration required for capture | 2.0 V, 3.0 V | 20 | | ns |

5.12.7 eUSCI

Table 5-14 lists the clock frequency of the eUSCI in UART mode.

Table 5-14. eUSCI (UART Mode) Clock Frequency

over recommended ranges of supply voltage and operating free-air temperature (unless otherwise noted)

| PARAMETER | | TEST CONDITIONS | V _{CC} | MIN | MAX | UNIT |
|---------------------|---|--|-----------------|-----|-----|------|
| f _{eUSCI} | eUSCI input clock frequency | Internal: SMCLK or MODCLK, External: UCLK, Duty cycle = 50% ±10% | 2.0 V, 3.0 V | | 16 | MHz |
| f _{BITCLK} | BITCLK clock frequency (equals baud rate in Mbaud) | | 2.0 V, 3.0 V | | 5 | MHz |

Table 5-15 lists the switching characteristics of the eUSCI in UART mode.

Table 5-15. eUSCI (UART Mode) Switching Characteristics

over recommended ranges of supply voltage and operating free-air temperature (unless otherwise noted)

| PARAMETER | | TEST CONDITIONS | V _{CC} | MIN | TYP | MAX | UNIT |
|----------------|---|-----------------|-----------------|-----|-----|-----|------|
| t _t | UART receive deglitch time ⁽¹⁾ | UCGLITx = 0 | 2.0 V, 3.0 V | | 12 | | ns |
| | | UCGLITx = 1 | | | 40 | | |
| | | UCGLITx = 2 | | | 68 | | |
| | | UCGLITx = 3 | | | 110 | | |

(1) Pulses on the UART receive input (UCxRX) shorter than the UART receive deglitch time are suppressed. To make sure that pulses are correctly recognized, their duration must exceed the maximum specification of the deglitch time.

Table 5-16 lists the clock frequency of the eUSCI in SPI master mode.

Table 5-16. eUSCI (SPI Master Mode) Clock Frequency

over recommended ranges of supply voltage and operating free-air temperature (unless otherwise noted)

| PARAMETER | | CONDITIONS | MIN | MAX | UNIT |
|--------------------|-----------------------------|---|-----|-----|------|
| f _{eUSCI} | eUSCI input clock frequency | Internal: SMCLK or MODCLK, Duty cycle = 50% ±10% | | 8 | MHz |

Table 5-17 lists the switching characteristics of the eUSCI in SPI master mode.

Table 5-17. eUSCI (SPI Master Mode) Switching Characteristics

over recommended ranges of supply voltage and operating free-air temperature (unless otherwise noted)⁽¹⁾

| PARAMETER | | TEST CONDITIONS | V _{CC} | MIN | MAX | UNIT |
|-----------------------|--|---|-----------------|-----|-----|---------------|
| t _{STE,LEAD} | STE lead time, STE active to clock | UCSTEM = 1, UCMODEx = 01 or 10 | | 1 | | UCxCLK cycles |
| t _{STE,LAG} | STE lag time, last clock to STE inactive | UCSTEM = 1, UCMODEx = 01 or 10 | | 1 | | UCxCLK cycles |
| t _{SU,MI} | SOMI input data setup time | | 2.0 V | 47 | | ns |
| | | | 3.0 V | 35 | | |
| t _{HD,MI} | SOMI input data hold time | | 2.0 V | 0 | | ns |
| | | | 3.0 V | 0 | | |
| t _{VALID,MO} | SIMO output data valid time ⁽²⁾ | UCLK edge to SIMO valid, C _L = 20 pF | 2.0 V | | 20 | ns |
| | | | 3.0 V | | 20 | |
| t _{HD,MO} | SIMO output data hold time ⁽³⁾ | C _L = 20 pF | 2.0 V | 0 | | ns |
| | | | 3.0 V | 0 | | |

(1) f_{UCxCLK} = 1/2t_{LO/HI} with t_{LO/HI} = max(t_{VALID,MO(eUSCI)} + t_{SU,SI(Slave)}, t_{SU,MI(eUSCI)} + t_{VALID,SO(Slave)})

For the slave parameters t_{SU,SI(Slave)} and t_{VALID,SO(Slave)}, see the SPI parameters of the attached slave.

(2) Specifies the time to drive the next valid data to the SIMO output after the output changing UCLK clock edge. See the timing diagrams in Figure 5-10 and Figure 5-11.

(3) Specifies how long data on the SIMO output is valid after the output changing UCLK clock edge. Negative values indicate that the data on the SIMO output can become invalid before the output changing clock edge observed on UCLK. See the timing diagrams in Figure 5-10 and Figure 5-11.

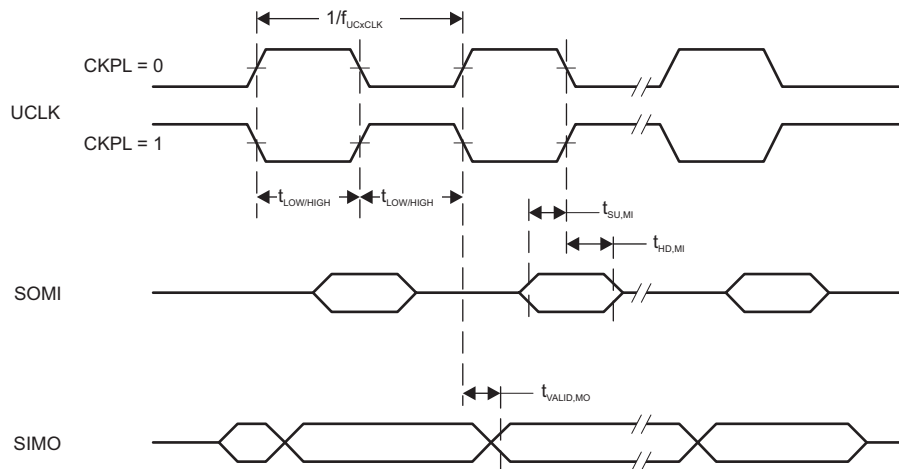

Figure 5-10. SPI Master Mode, CKPH = 0

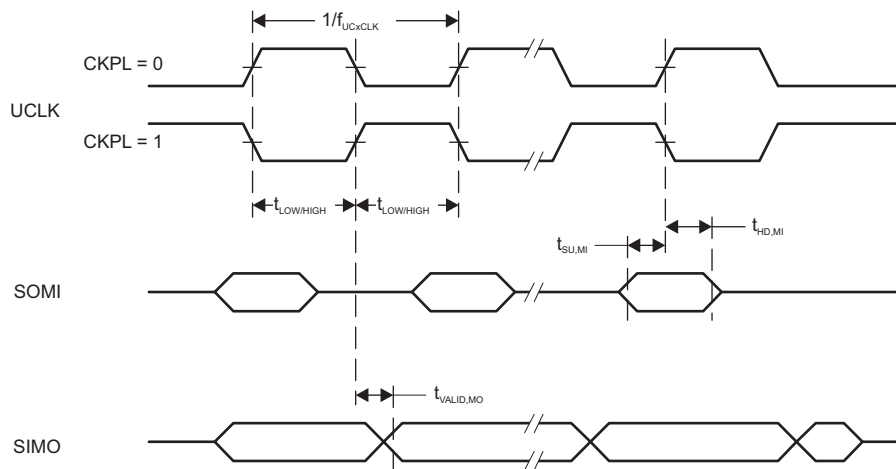

Figure 5-11. SPI Master Mode, CKPH = 1

Table 5-18 lists the switching characteristics of the eUSCI in SPI slave mode.

Table 5-18. eUSCI (SPI Slave Mode) Switching Characteristics

over recommended ranges of supply voltage and operating free-air temperature (unless otherwise noted)⁽¹⁾

| PARAMETER | | TEST CONDITIONS | V _{CC} | MIN | MAX | UNIT |
|-----------------------|---|--|-----------------|-----|-----|------|
| t _{STE,LEAD} | STE lead time, STE active to clock | | 2.0 V | 55 | | ns |
| | | | 3.0 V | 45 | | |
| t _{STE,LAG} | STE lag time, last clock to STE inactive | | 2.0 V | 20 | | ns |
| | | | 3.0 V | 20 | | |
| t _{STE,ACC} | STE access time, STE active to SOMI data out | | 2.0 V | | 65 | ns |
| | | | 3.0 V | | 40 | |
| t _{STE,DIS} | STE disable time, STE inactive to SOMI high impedance | | 2.0 V | | 40 | ns |
| | | | 3.0 V | | 35 | |
| t _{SU,SI} | SIMO input data setup time | | 2.0 V | 8 | | ns |
| | | | 3.0 V | 6 | | |
| t _{HD,SI} | SIMO input data hold time | | 2.0 V | 12 | | ns |
| | | | 3.0 V | 12 | | |
| t _{VALID,SO} | SOMI output data valid time ⁽²⁾ | UCLK edge to SOMI valid, C _L = 20 pF | 2.0 V | | 68 | ns |
| | | | 3.0 V | | 42 | |
| t _{HD,SO} | SOMI output data hold time ⁽³⁾ | C _L = 20 pF | 2.0 V | 5 | | ns |
| | | | 3.0 V | 5 | | |

(1) $f_{UCxCLK} = 1/2t_{LO/HI}$ with $t_{LO/HI} \geq \max(t_{VALID,MO(Master)} + t_{SU,SI(eUSCI)}, t_{SU,MI(Master)} + t_{VALID,SO(eUSCI)})$

For the master parameters $t_{SU,MI(Master)}$ and $t_{VALID,MO(Master)}$, see the SPI parameters of the attached master.

(2) Specifies the time to drive the next valid data to the SOMI output after the output changing UCLK clock edge. See the timing diagrams in Figure 5-12 and Figure 5-13.

(3) Specifies how long data on the SOMI output is valid after the output changing UCLK clock edge. See the timing diagrams in Figure 5-12 and Figure 5-13.

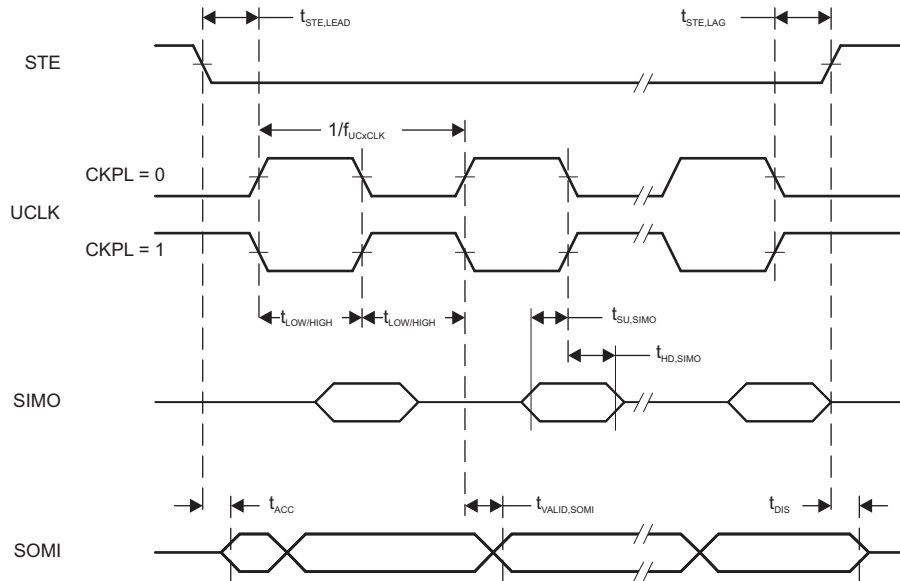

Figure 5-12. SPI Slave Mode, CKPH = 0

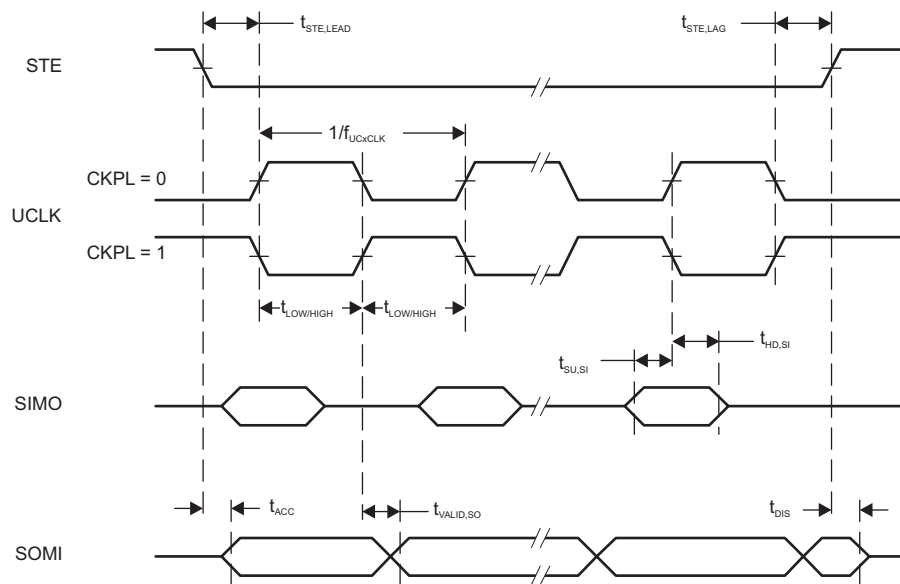

Figure 5-13. SPI Slave Mode, CKPH = 1

Table 5-19 lists the switching characteristics of the eUSCI (I²C mode).

Table 5-19. eUSCI (I²C Mode) Switching Characteristics

over recommended ranges of supply voltage and operating free-air temperature (unless otherwise noted) (see Figure 5-14)

| PARAMETER | TEST CONDITIONS | V _{CC} | MIN | TYP | MAX | UNIT |
|----------------------|---|--|--------------|-------------------------|-------------------------|------|
| f _{eUSCI} | eUSCI input clock frequency | | | | 16 | MHz |
| f _{SCL} | SCL clock frequency | 2.0 V, 3.0 V | 0 | | 400 | kHz |
| t _{HD,STA} | Hold time (repeated) START | f _{SCL} = 100 kHz f _{SCL} > 100 kHz | 2.0 V, 3.0 V | 4.0 0.6 | | μs |
| t _{SU,STA} | Setup time for a repeated START | f _{SCL} = 100 kHz f _{SCL} > 100 kHz | 2.0 V, 3.0 V | 4.7 0.6 | | μs |
| t _{HD,DAT} | Data hold time | | 2.0 V, 3.0 V | 0 | | ns |
| t _{SU,DAT} | Data setup time | | 2.0 V, 3.0 V | 250 | | ns |
| t _{SU,STO} | Setup time for STOP | f _{SCL} = 100 kHz f _{SCL} > 100 kHz | 2.0 V, 3.0 V | 4.0 0.6 | | μs |
| t _{SP} | Pulse duration of spikes suppressed by input filter | UCGLITx = 0 UCGLITx = 1 UCGLITx = 2 UCGLITx = 3 | 2.0 V, 3.0 V | 50 25 12.5 6.3 | 600 300 150 75 | ns |
| t _{TIMEOUT} | Clock low time-out | UCCLTOx = 1 UCCLTOx = 2 UCCLTOx = 3 | 2.0 V, 3.0 V | 27 30 33 | | ms |

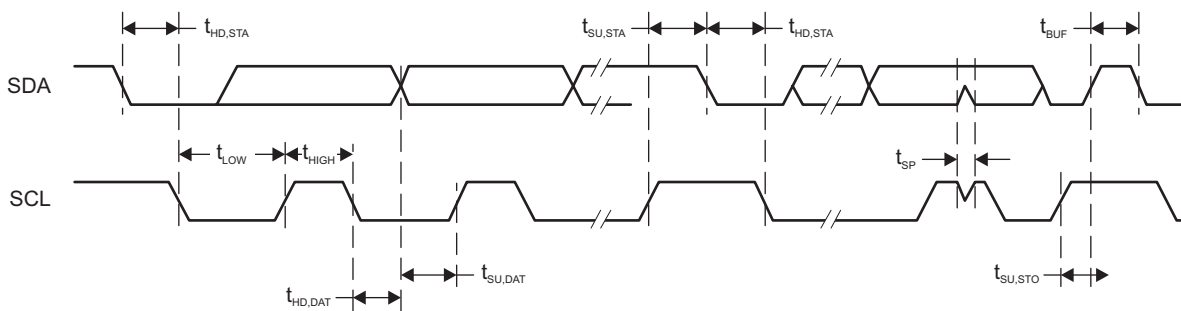

Figure 5-14. I²C Mode Timing

5.12.8 ADC

Table 5-20 lists the characteristics of the ADC power supply and input range conditions.

Table 5-20. ADC, Power Supply and Input Range Conditions

over operating free-air temperature range (unless otherwise noted)

| PARAMETER | | TEST CONDITIONS | V _{CC} | MIN | TYP | MAX | UNIT |
|---------------------|---|--|-----------------|-----|-----|------------------|------|
| DV _{CC} | ADC supply voltage | | | 2.0 | | 3.6 | V |
| V _(Ax) | Analog input voltage range | All ADC pins | | 0 | | DV _{CC} | V |
| I _{ADC} | Operating supply current into DV _{CC} terminal, reference current not included, repeat-single-channel mode | f _{ADCCLK} = 5 MHz, ADCON = 1, REFON = 0, SHT0 = 0, SHT1 = 0, ADCDIV = 0, ADCCONSEQx = 10b | 2 V | | 185 | | μA |
| | | | 3 V | | 207 | | |
| C _I | Input capacitance | Only one terminal Ax can be selected at one time from the pad to the ADC capacitor array, including wiring and pad | 2.2 V | | 2.5 | 3.5 | pF |
| R _{I,MUX} | Input MUX ON resistance | DV _{CC} = 2 V, 0 V ≤ V _{Ax} ≤ DV _{CC} | | | | 2 | kΩ |
| R _{I,Misc} | Input miscellaneous resistance | | | | 34 | | kΩ |

Table 5-21 lists the ADC 10-bit timing parameters.

Table 5-21. ADC, 10-Bit Timing Parameters

over operating free-air temperature range (unless otherwise noted)

| PARAMETER | | TEST CONDITIONS | V _{CC} | MIN | TYP | MAX | UNIT |
|----------------------|----------------------------------|---|-----------------|------|---------------------------------|------|------|
| f _{ADCCLK} | | For specified performance of ADC linearity parameters | 2 V to 3.6 V | 0.45 | 5 | 5.5 | MHz |
| f _{ADCOSC} | Internal ADC oscillator (MODOSC) | ADCDIV = 0, f _{ADCCLK} = f _{ADCOSC} | 2 V to 3.6 V | 3.8 | 4.8 | 5.8 | MHz |
| t _{CONVERT} | Conversion time | REFON = 0, Internal oscillator, 10 ADCCLK cycles, 10-bit mode, f _{ADCOSC} = 4.5 MHz to 5.5 MHz | 2 V to 3.6 V | 2.18 | | 2.67 | μs |
| | | External f _{ADCCLK} from ACLK, MCLK, or SMCLK, ADCSSEL ≠ 0 | 2 V to 3.6 V | | 12 × 1 / f _{ADCCLK} | | |
| t _{ADCON} | Turn-on settling time of the ADC | The error in a conversion started after t _{ADCON} is less than ±0.5 LSB. Reference and input signal are already settled. | | | | 100 | ns |
| t _{SAMPLE} | Sampling time | R _S = 1000 Ω, R _I ⁽¹⁾ = 36000 Ω, C _I = 3.5 pF, Approximately 8 Tau (τ) are required for an error of less than ±0.5 LSB ⁽²⁾ | 2 V | 1.5 | | | μs |
| | | | 3 V | 2.0 | | | |

(1) R_I = R_{I,MUX} + R_{I,Misc}

(2) t_{sample} = ln(2ⁿ⁺¹) × τ, where n = ADC resolution, τ = (R_I + R_S) × C_I

Table 5-22 lists the ADC 10-bit linearity parameters.

Table 5-22. ADC, 10-Bit Linearity Parameters

over operating free-air temperature range (unless otherwise noted)

| PARAMETER | | TEST CONDITIONS | V _{CC} | MIN | TYP | MAX | UNIT |
|---------------------------------|---|--|-----------------|-------|------|------|-------|
| E _I | Integral linearity error (10-bit mode) | V _{ref+} reference | 2.4 V to 3.6 V | -2 | | 2 | LSB |
| | Integral linearity error (8-bit mode) | | 2.0 V to 3.6 V | -2 | | 2 | |
| E _D | Differential linearity error (10-bit mode) | V _{ref+} reference | 2.4 V to 3.6 V | -1 | | 1 | LSB |
| | Differential linearity error (8-bit mode) | | 2.0 V to 3.6 V | -1 | | 1 | |
| E _O | Offset error (10-bit mode) | V _{ref+} reference | 2.4 V to 3.6 V | -6.5 | | 6.5 | mV |
| | Offset error (8-bit mode) | | 2.0 V to 3.6 V | -6.5 | | 6.5 | |
| E _G | Gain error (10-bit mode) | V _{ref+} as reference | 2.4 V to 3.6 V | -2.0 | | 2.0 | LSB |
| | | Internal 1.5-V reference | | -3.0% | | 3.0% | |
| | Gain error (8-bit mode) | V _{ref+} as reference | 2.0 V to 3.6 V | -2.0 | | 2.0 | LSB |
| | | Internal 1.5-V reference | | -3.0% | | 3.0% | |
| E _T | Total unadjusted error (10-bit mode) | V _{ref+} as reference | 2.4 V to 3.6 V | -2.0 | | 2.0 | LSB |
| | | Internal 1.5-V reference | | -3.0% | | 3.0% | |
| | Total unadjusted error (8-bit mode) | V _{ref+} as reference | 2.0 V to 3.6 V | -2.0 | | 2.0 | LSB |
| | | Internal 1.5-V reference | | -3.0% | | 3.0% | |
| V _{SENSOR} | See ⁽¹⁾ | ADCON = 1, INCH = 0Ch, T _A = 0°C | 3 V | | 913 | | mV |
| TC _{SENSOR} | See ⁽²⁾ | ADCON = 1, INCH = 0Ch | 3 V | | 3.35 | | mV/°C |
| t _{SENSOR} (sample) | Sample time required if channel 12 is selected ⁽³⁾ | ADCON = 1, INCH = 0Ch, Error of conversion result ≤ 1 LSB, AM and all LPMs above LPM3 | 3 V | | 30 | | μs |
| | | ADCON = 1, INCH = 0Ch, Error of conversion result ≤ 1 LSB, LPM3 | 3 V | | 100 | | |

- (1) The temperature sensor offset can vary significantly. TI recommends a single-point calibration to minimize the offset error of the built-in temperature sensor.
- (2) The device descriptor structure contains calibration values for 30°C and 85°C for each available reference voltage level. The sensor voltage can be computed as $V_{SENSE} = TC_{SENSOR} \times (\text{Temperature, } ^\circ\text{C}) + V_{SENSOR}$, where TC_{SENSOR} and V_{SENSOR} can be computed from the calibration values for higher accuracy.
- (3) The typical equivalent impedance of the sensor is 700 kΩ. The sample time required includes the sensor on time, t_{SENSOR(on)}.

5.12.9 Enhanced Comparator (eCOMP)

Table 5-23 lists the characteristics of eCOMP0.

Table 5-23. eCOMP0

over recommended ranges of supply voltage and operating free-air temperature (unless otherwise noted)

| PARAMETER | TEST CONDITIONS | MIN | TYP | MAX | UNIT | |
|------------------------|---|---|-----|-----------------|------|----|
| V _{CC} | Supply voltage | 2.0 | | 3.6 | V | |
| V _{IC} | Common-mode input range | 0 | | V _{CC} | V | |
| V _{HYS} | DC input hysteresis | CPEN = 1, CPHSEL = 00 | | 0 | mV | |
| | | CPEN = 1, CPHSEL = 01 | | 10 | | |
| | | CPEN = 1, CPHSEL = 10 | | 20 | | |
| | | CPEN = 1, CPHSEL = 11 | | 30 | | |
| V _{OFFSET} | Input offset voltage | CPEN = 1, CPMSEL = 0 | | -30 | +30 | mV |
| | | CPEN = 1, CPMSEL = 1 | | -40 | +40 | |
| I _{COMP} | Quiescent current draw from V _{CC} , only comparator | V _{IC} = V _{CC} / 2, CPEN = 1, CPMSEL = 0 | | 24 | 35 | μA |
| | | V _{IC} = V _{CC} / 2, CPEN = 1, CPMSEL = 1 | | 1.6 | 5 | |
| C _{IN} | Input channel capacitance ⁽¹⁾ | | 1 | | pF | |
| R _{IN} | Input channel series resistance | On (switch closed) | | 10 | 20 | kΩ |
| | | Off (switch open) | | 50 | | |
| t _{PD} | Propagation delay, response time | CPMSEL = 0, CPFLT = 0, V _{IC} = V _{CC} / 2, Overdrive = 20 mV | | | 1 | μs |
| | | CPMSEL = 1, CPFLT = 0, V _{IC} = V _{CC} / 2, Overdrive = 20 mV | | 3.2 | | |
| t _{EN_CP} | Comparator enable time | CPEN = 0→1, CPMSEL = 0, V+ and V- from pads, Overdrive = 20 mV | | 8.5 | | μs |
| | | CPEN = 0→1, CPMSEL = 1, V+ and V- from pads, Overdrive = 20 mV | | 1.4 | | |
| t _{EN_CP_DAC} | Comparator with reference DAC enable time | CPEN = 0→1, CPDACEN = 0→1, CPMSEL = 0, CPDACREFS = 1, CPDACBUF1 = 0F, Overdrive = 20 mV | | 8.5 | | μs |
| | | CPEN = 0→1, CPDACEN = 0→1, CPMSEL = 1, CPDACREFS = 1, CPDACBUF1 = 0F, Overdrive = 20 mV | | 101 | | |
| t _{FDLY} | Propagation delay with analog filter active | CPMSEL = 0, CPFLTDY = 00, Overdrive = 20 mV, CPFLT = 1 | | 0.7 | | μs |
| | | CPMSEL = 0, CPFLTDY = 01, Overdrive = 20 mV, CPFLT = 1 | | 1.1 | | |
| | | CPMSEL = 0, CPFLTDY = 10, Overdrive = 20 mV, CPFLT = 1 | | 1.9 | | |
| | | CPMSEL = 0, CPFLTDY = 11, Overdrive = 20 mV, CPFLT = 1 | | 3.4 | | |
| INL | Integral nonlinearity | -0.5 | | 0.5 | LSB | |
| DNL | Differential nonlinearity | -0.5 | | 0.5 | LSB | |

(1) eCOMP C_{IN} model, see Figure 5-15 for details.

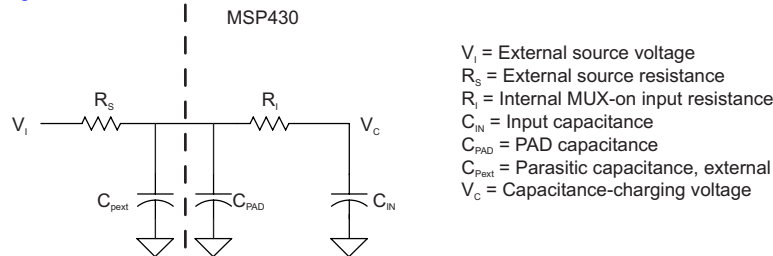

Figure 5-15. eCOMP Input Circuit

5.12.10 Smart Analog Combo (SAC)

Table 5-24 lists the characteristics of SAC0 (SAC-L1, OA).

Table 5-24. SAC0 (SAC-L1, OA)

over recommended ranges of supply voltage and operating free-air temperature (unless otherwise noted)

| PARAMETER | | TEST CONDITIONS | MIN | TYP | MAX | UNIT |
|--------------|--|--|------|----------------|-----|-------------------|
| V_{CC} | Supply voltage | | 2.0 | | 3.6 | V |
| V_{OS} | Input offset voltage | | -5 | | 5 | mV |
| dV_{OS}/dT | Offset drift | OAPM = 0 | | 3 | | $\mu V/^{\circ}C$ |
| | | OAPM = 1 | | 5 | | |
| I_B | Input bias current | | | 50 | | μA |
| V_{CM} | Input voltage range | | -0.1 | $V_{CC} + 0.1$ | | V |
| I_{IDD} | Quiescent current | OAPM = 0 | | 350 | | μA |
| | | OAPM = 1 | | 120 | | |
| E_{NI} | Input noise voltage, f = 0.1 Hz to 10 Hz | $V_{in} = V_{CC} / 2$, OAPM = 0 | | 40 | | μV |
| | Input noise voltage density, f = 1 kHz | $V_{in} = V_{CC} / 2$, OAPM = 0 | | 40 | | nV/\sqrt{Hz} |
| | Input noise voltage, f = 10 kHz | $V_{in} = V_{CC} / 2$, OAPM = 0 | | 20 | | |
| CMRR | Common-mode rejection ratio | OAPM = 0 | | 70 | | dB |
| | | OAPM = 1 | | 80 | | |
| PSRR | Power supply rejection ratio | OAPM = 0 | | 70 | | dB |
| | | OAPM = 1 | | 80 | | |
| GBW | Gain bandwidth | OAPM = 0 | | 4 | | MHz |
| | | OAPM = 1 | | 1.4 | | |
| A_{OL} | Open-loop voltage gain | OAPM = 0 | | 100 | | dB |
| | | OAPM = 1 | | 100 | | |
| ϕ_M | Phase margin | $C_L = 50 \text{ pF}$, $R_L = 2 \text{ k}\Omega$ | | 65 | | deg |
| | Positive slew rate | $C_L = 50 \text{ pF}$, OAPM = 0 | | 3 | | V/us |
| | | $C_L = 50 \text{ pF}$, OAPM = 1 | | 1 | | |
| C_{in} | Input capacitance | Common mode | | 2 | | pF |
| V_O | Voltage output swing from supply rails | $R_L = 10 \text{ k}\Omega$ | | 40 | 100 | mV |
| t_{ST} | OA settling time | To 0.1% final value, G = +1, 1-V setup, $C_L = 50 \text{ pF}$, OAPM = 0 | | 1 | | μs |
| | | To 0.1% final value, G = +1, 1-V setup, $C_L = 50 \text{ pF}$, OAPM = 1 | | 4.5 | | |

5.12.11 Transimpedance Amplifier (TIA)

Table 5-25 lists the characteristics of TIA0.

Table 5-25. TIA0

over recommended ranges of supply voltage and operating free-air temperature (unless otherwise noted)

| PARAMETER | | TEST CONDITIONS | MIN | TYP | MAX | UNIT |
|--------------|--|--|------|------------|-----|-------------------|
| V_{CC} | Supply voltage | | 2.0 | | 3.6 | V |
| V_{OS} | Input offset voltage | | -5 | | 5 | mV |
| dV_{OS}/dT | Offset drift | TRIPM = 0 | | 3 | | $\mu V/^{\circ}C$ |
| | | TRIPM = 1 | | 5 | | |
| I_B | Input bias current | $V_B = 0$ V, TSSOP-16 package with OA-dedicated pin input (see Figure 4-2) | | 5 | | pA |
| | | TSSOP-20 and VQFN-16 packages | | 50 | | pA |
| V_{CM} | Input voltage range | | -0.1 | $V_{CC}/2$ | | V |
| I_{DD} | Quiescent current | TRIPM = 0 | | 350 | | μA |
| | | TRIPM = 1 | | 120 | | |
| E_{NI} | Input noise voltage, f = 0.1 Hz to 10 Hz | $V_{in} = V_{CC}/2$, TRIPM = 0 | | 40 | | μV |
| | Input noise voltage density, f = 1 kHz | $V_{in} = V_{CC}/2$, TRIPM = 0 | | 40 | | nV/\sqrt{Hz} |
| | Input noise voltage, f = 10 kHz | $V_{in} = V_{CC}/2$, TRIPM = 0 | | 16 | | |
| CMRR | Common-mode rejection ratio | TRIPM = 0 | | 80 | | dB |
| | | TRIPM = 1 | | 70 | | |
| PSRR | Power supply rejection ratio | TRIPM = 0 | | 80 | | dB |
| | | TRIPM = 1 | | 70 | | |
| GBW | Gain bandwidth | TRIPM = 0 | | 5 | | MHz |
| | | TRIPM = 1 | | 1.8 | | |
| A_{OL} | Open-loop voltage gain | TRIPM = 0 | | 100 | | dB |
| | | TRIPM = 1 | | 100 | | |
| ϕ_M | Phase margin | $C_L = 50$ pF, $R_L = 2$ k Ω , TRIPM = 0 | | 40 | | deg |
| | | $C_L = 50$ pF, $R_L = 2$ k Ω , TRIPM = 1 | | 70 | | |
| | Positive slew rate | $C_L = 50$ pF, TRIPM = 0 | | 4 | | V/ μs |
| | | $C_L = 50$ pF, TRIPM = 1 | | 1 | | |
| C_{in} | Input capacitance | Common mode | | 7 | | pF |
| V_O | Voltage output swing from supply rails | $R_L = 10$ k Ω | | 40 | 100 | mV |
| t_{ST} | TIA settling time | To 0.1% final value, G = +1, 1-V setup, $C_L = 50$ pF, TRIPM = 0 | | 3 | | μs |
| | | To 0.1% final value, G = +1, 1-V setup, $C_L = 50$ pF, TRIPM = 1 | | 5 | | |

5.12.12 FRAM

Table 5-26 lists the characteristics of the FRAM.

Table 5-26. FRAM

over recommended ranges of supply voltage and operating free-air temperature (unless otherwise noted)

| PARAMETER | | TEST CONDITIONS | MIN | TYP | MAX | UNIT |
|------------------------|----------------------------|-----------------------|------------------|--------------------------------------|-----|--------|
| | Read and write endurance | | 10 ¹⁵ | | | cycles |
| t _{Retention} | Data retention duration | T _J = 25°C | 100 | | | years |
| | | T _J = 70°C | 40 | | | |
| | | T _J = 85°C | 10 | | | |
| I _{WRITE} | Current to write into FRAM | | | I _{READ} ⁽¹⁾ | | nA |
| I _{ERASE} | Erase current | | | N/A ⁽²⁾ | | nA |
| t _{WRITE} | Write time | | | t _{READ} ⁽³⁾ | | ns |
| t _{READ} | Read time | NWAITSx = 0 | | 1/f _{SYSTEM} ⁽⁴⁾ | | ns |
| | | NWAITSx = 1 | | 2/f _{SYSTEM} ⁽⁴⁾ | | |

- (1) Writing to FRAM does not require a setup sequence or additional power when compared to reading from FRAM. The FRAM read current I_{READ} is included in the active mode current consumption numbers I_{AM, FRAM}.
- (2) FRAM does not require a special erase sequence.
- (3) Writing into FRAM is as fast as reading.
- (4) The maximum read (and write) speed is specified by f_{SYSTEM} using the appropriate wait state settings (NWAITSx).

5.12.13 Emulation and Debug

Table 5-27 lists the characteristics of the 2-wire Spy-Bi-Wire interface.

Table 5-27. JTAG, Spy-Bi-Wire Interface

over recommended ranges of supply voltage and operating free-air temperature (unless otherwise noted) (see Figure 5-16)

| PARAMETER | | V _{CC} | MIN | TYP | MAX | UNIT |
|----------------------------|--|-----------------|-------|-----|-----|------|
| f _{SBW} | Spy-Bi-Wire input frequency | 2.0 V, 3.0 V | 0 | | 8 | MHz |
| t _{SBW,Low} | Spy-Bi-Wire low clock pulse duration | 2.0 V, 3.0 V | 0.028 | | 15 | µs |
| t _{SU,SBWTDIO} | SBWTDIO setup time (before falling edge of SBWTCK in TMS and TDI slot Spy-Bi-Wire) | 2.0 V, 3.0 V | 4 | | | ns |
| t _{HD,SBWTDIO} | SBWTDIO hold time (after rising edge of SBWTCK in TMS and TDI slot Spy-Bi-Wire) | 2.0 V, 3.0 V | 19 | | | ns |
| t _{Valid,SBWTDIO} | SBWTDIO data valid time (after falling edge of SBWTCK in TDO slot Spy-Bi-Wire) | 2.0 V, 3.0 V | | | 31 | ns |
| t _{SBW,En} | Spy-Bi-Wire enable time (TEST high to acceptance of first clock edge) ⁽¹⁾ | 2.0 V, 3.0 V | | | 110 | µs |
| t _{SBW,Ret} | Spy-Bi-Wire return to normal operation time ⁽²⁾ | | 15 | | 100 | µs |
| R _{Internal} | Internal pulldown resistance on TEST | 2.0 V, 3.0 V | 20 | 35 | 50 | kΩ |

- (1) Tools that access the Spy-Bi-Wire interface must wait for the t_{SBW,En} time after pulling the TEST/SBWTCK pin high before applying the first SBWTCK clock edge.
- (2) Maximum t_{SBW,Ret} time after pulling or releasing the TEST/SBWTCK pin low, the Spy-Bi-Wire pins revert from their Spy-Bi-Wire function to their application function. This time applies only if the Spy-Bi-Wire mode was selected.

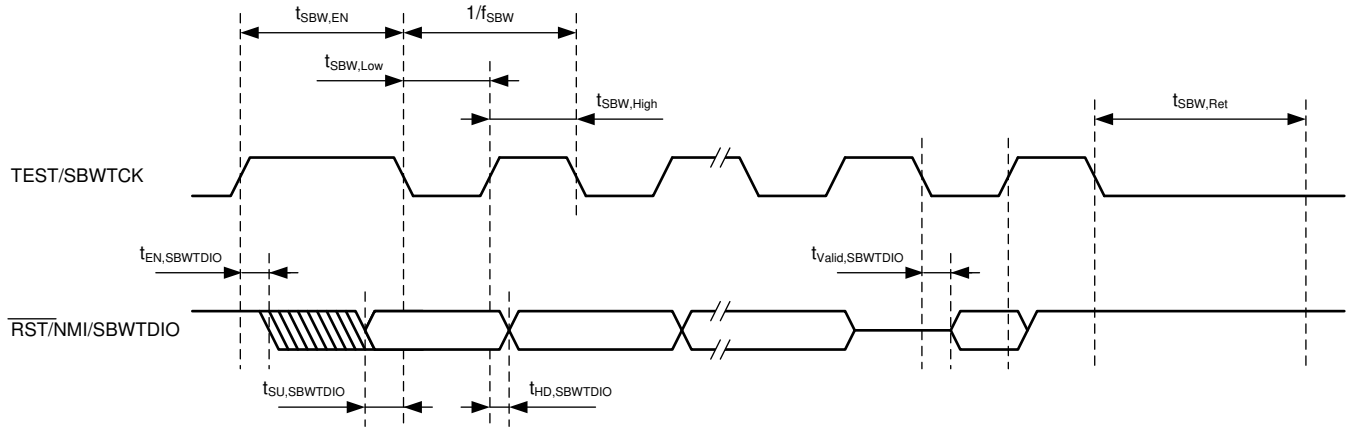

Figure 5-16. JTAG Spy-Bi-Wire Timing

Table 5-28 lists the characteristics of the JTAG 4-wire interface.

Table 5-28. JTAG, 4-Wire Interface

over recommended ranges of supply voltage and operating free-air temperature (unless otherwise noted) (see Figure 5-17)

| PARAMETER | | V _{CC} | MIN | TYP | MAX | UNIT |
|--------------------------|---|-----------------|-----|-----|-----|------|
| f _{TCK} | TCK input frequency ⁽¹⁾ | 2.0 V, 3.0 V | 0 | | 10 | MHz |
| t _{TCK,Low} | Spy-Bi-Wire low clock pulse duration | 2.0 V, 3.0 V | 15 | | | ns |
| t _{TCK,high} | Spy-Bi-Wire high clock pulse duration | 2.0 V, 3.0 V | 15 | | | ns |
| t _{SU,TMS} | TMS setup time (before rising edge of TCK) | 2.0 V, 3.0 V | 11 | | | ns |
| t _{HD,TMS} | TMS hold time (after rising edge of TCK) | 2.0 V, 3.0 V | 3 | | | ns |
| t _{SU,TDI} | TDI setup time (before rising edge of TCK) | 2.0 V, 3.0 V | 13 | | | ns |
| t _{HD,TDI} | TDI hold time (after rising edge of TCK) | 2.0 V, 3.0 V | 5 | | | ns |
| t _{z-Valid,TDO} | TDO high impedance to valid output time (after falling edge of TCK) | 2.0 V, 3.0 V | | | 26 | ns |
| t _{Valid,TDO} | TDO to new valid output time (after falling edge of TCK) | 2.0 V, 3.0 V | | | 26 | ns |
| t _{Valid-Z,TDO} | TDO valid to high-impedance output time (after falling edge of TCK) | 2.0 V, 3.0 V | | | 26 | ns |
| t _{JTAG,Ret} | Spy-Bi-Wire return to normal operation time | | 15 | | 100 | μs |
| R _{internal} | Internal pulldown resistance on TEST | 2.0 V, 3.0 V | 20 | 35 | 50 | kΩ |

(1) Tools that access the Spy-Bi-Wire interface must wait for the t_{SBW,En} time after pulling the TEST/SBWTCK pin high before applying the first SBWTCK clock edge.

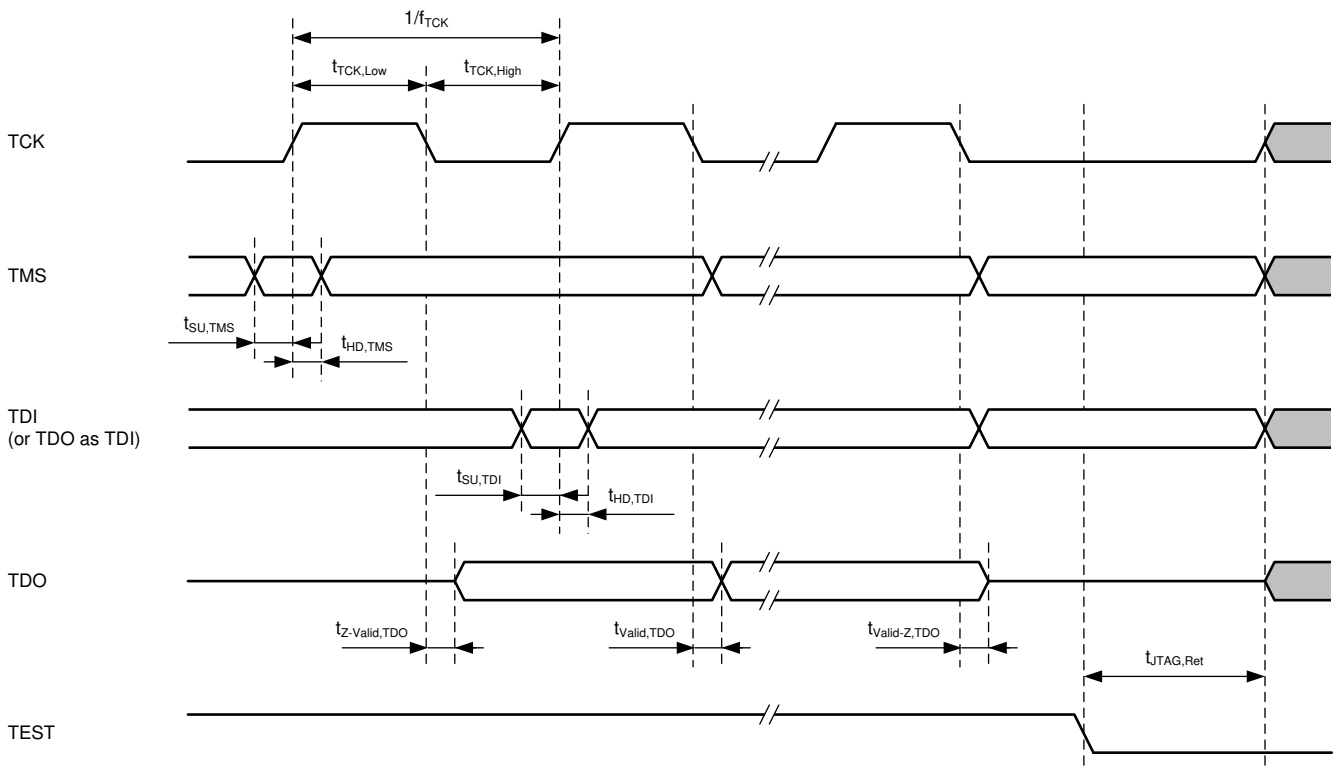

Figure 5-17. JTAG 4-Wire Timing

6 Detailed Description

6.1 Overview

The MSP430FR231x FRAM MCU features a powerful 16-bit RISC CPU, 16-bit registers, and constant generators that contribute to maximum code efficiency. The DCO also allows the device to wake up from low-power modes to active mode typically in less than 10 μ s. The feature set of this microcontroller is ideal for applications ranging from smoke detectors to portable health and fitness accessories.

6.2 CPU

The MSP430 CPU has a 16-bit RISC architecture that is highly transparent to the application. All operations, other than program-flow instructions, are performed as register operations in conjunction with seven addressing modes for source operand and four addressing modes for destination operand.

The CPU is integrated with 16 registers that provide reduced instruction execution time. The register-to-register operation execution time is one cycle of the CPU clock.

Four of the registers, R0 to R3, are dedicated as program counter (PC), stack pointer (SP), status register (SR), and constant generator (CG), respectively. The remaining registers are general-purpose registers.

Peripherals are connected to the CPU using data, address, and control buses, and can be handled with all instructions.

6.3 Operating Modes

The MSP430 has one active mode and several software-selectable low-power modes of operation (see [Table 6-1](#)). An interrupt event can wake up the device from low-power mode (LPM0, LPM3, or LPM4), service the request, and restore back to the low-power mode on return from the interrupt program. Low-power modes LPM3.5 and LPM4.5 disable the core supply to minimize power consumption.

Table 6-1. Operating Modes

| MODE | | AM | LPM0 | LPM3 | LPM4 | LPM3.5 | LPM4.5 |
|--------------------------------|-----------|-----------------|-----------------|--|--------------------------|--|-------------------|
| | | ACTIVE MODE | CPU OFF | STANDBY | OFF | ONLY RTC COUNTER | SHUTDOWN |
| Maximum system clock | | 16 MHz | 16 MHz | 40 kHz | 0 | 40 kHz | 0 |
| Power consumption at 25°C, 3 V | | 126 μ A/MHz | 40 μ A/MHz | 1.11 μ A with RTC counter only in LFXT | 0.45 μ A without SVS | 0.71 μ A with RTC counter only in LFXT | 32 nA without SVS |
| Wake-up time | | N/A | instant | 10 μ s | 10 μ s | 350 μ s | 350 μ s |
| Wake-up events | | N/A | All | All | I/O | RTC Counter I/O | I/O |
| Power | Regulator | Full Regulation | Full Regulation | Partial Power Down | Partial Power Down | Partial Power Down | Power Down |
| | SVS | On | On | Optional | Optional | Optional | Optional |
| | Brownout | On | On | On | On | On | On |

Table 6-1. Operating Modes (continued)

| MODE | | AM | LPM0 | LPM3 | LPM4 | LPM3.5 | LPM4.5 |
|----------------------|------------------------------|-------------|----------|------------|--------------------|------------------|------------|
| | | ACTIVE MODE | CPU OFF | STANDBY | OFF | ONLY RTC COUNTER | SHUTDOWN |
| Clock ⁽¹⁾ | MCLK | Active | Off | Off | Off | Off | Off |
| | SMCLK | Optional | Optional | Off | Off | Off | Off |
| | FLL | Optional | Optional | Off | Off | Off | Off |
| | DCO | Optional | Optional | Off | Off | Off | Off |
| | MODCLK | Optional | Optional | Off | Off | Off | Off |
| | REFO | Optional | Optional | Optional | Off | Off | Off |
| | ACLK | Optional | Optional | Optional | Off | Off | Off |
| | XT1HFCLK ⁽²⁾ | Optional | Optional | Off | Off | Off | Off |
| | XT1LFCLK | Optional | Optional | Optional | Off ⁽³⁾ | Optional | Off |
| | VLOCLK | Optional | Optional | Optional | Off ⁽³⁾ | Optional | Off |
| Core | CPU | On | Off | Off | Off | Off | Off |
| | FRAM | On | On | Off | Off | Off | Off |
| | RAM | On | On | On | On | Off | Off |
| | Backup Memory ⁽⁴⁾ | On | On | On | On | On | Off |
| Peripherals | Timer0_B3 | Optional | Optional | Optional | Off | Off | Off |
| | Timer1_B3 | Optional | Optional | Optional | Off | Off | Off |
| | WDT | Optional | Optional | Optional | Off | Off | Off |
| | eUSCI_A0 | Optional | Optional | Optional | Off | Off | Off |
| | eUSCI_B0 | Optional | Optional | Optional | Off | Off | Off |
| | CRC | Optional | Optional | Off | Off | Off | Off |
| | ADC | Optional | Optional | Optional | Off | Off | Off |
| | eCOMP | Optional | Optional | Optional | Optional | Off | Off |
| | TIA | Optional | Optional | Optional | Optional | Off | Off |
| | SAC0 | Optional | Optional | Optional | Optional | Off | Off |
| | RTC Counter | Optional | Optional | Optional | Off | Optional | Off |
| I/O | General Digital Input/Output | On | Optional | State Held | State Held | State Held | State Held |
| | Capacitive Touch I/O | Optional | Optional | Optional | Off | Off | Off |

(1) The status shown for LPM4 applies to internal clocks only.

(2) HFXT must be disabled before entering into LPM3, LPM4, or LPMx.5 mode.

(3) Refer to following NOTE for details info as below.

(4) Backup memory contains one 32-byte register in the peripheral memory space. See [Table 6-23](#) and [Table 6-38](#) for the memory allocation of backup memory.

NOTE

XT1CLK and VLOCLK can be active during LPM4 if requested by low-frequency peripherals.

6.4 Interrupt Vector Addresses

The interrupt vectors and the power-up start address are in the address range 0FFFFh to 0FF80h (see [Table 6-2](#)). The vector contains the 16-bit address of the interrupt-handler instruction sequence.

Table 6-2. Interrupt Sources, Flags, and Vectors

| INTERRUPT SOURCE | INTERRUPT FLAG | SYSTEM INTERRUPT | WORD ADDRESS | PRIORITY |
|---|--|------------------|----------------|-------------|
| System Reset Power-up, Brownout, Supply Supervisor External Reset RST Watchdog Time-out, Key Violation FRAM uncorrectable bit error detection Software POR, BOR FLL unlock error | SVSHIFG PMMRSTIFG WDTIFG PMMPORIFG, PMMBORIFG SYSRSTIV FLLULPUC | Reset | FFFEh | 63, Highest |
| System NMI Vacant Memory Access JTAG Mailbox FRAM access time error FRAM bit error detection | VMAIFG JMBINIFG, JMBOUTIFG CBDIFG, UBDIFG | (Non)maskable | FFFCh | 62 |
| User NMI External NMI Oscillator Fault | NMIIFG OFIFG | (Non)maskable | FFFAh | 61 |
| Timer0_B3 | TB0CCR0 CCIFG0 | Maskable | FFF8h | 60 |
| Timer0_B3 | TB0CCR1 CCIFG1, TB0CCR2 CCIFG2, TB0IFG (TB0IV) | Maskable | FFF6h | 59 |
| Timer1_B3 | TB1CCR0 CCIFG0 | Maskable | FFF4h | 58 |
| Timer1_B3 | TB1CCR1 CCIFG1, TB1CCR2 CCIFG2, TB1IFG (TB1IV) | Maskable | FFF2h | 57 |
| RTC Counter | RTCIFG | Maskable | FFF0h | 56 |
| Watchdog Timer Interval mode | WDTIFG | Maskable | FFEEh | 55 |
| eUSCI_A0 Receive or Transmit | UCTXCFIFG, UCSTTIFG, UCRXIFG, UCTXIFG (UART mode) UCRXIFG, UCTXIFG (SPI mode) (UCA0IV)) | Maskable | FFECCh | 54 |
| eUSCI_B0 Receive or Transmit | UCB0RXIFG, UCB0TXIFG (SPI mode) UCALIFG, UCNACKIFG, UCSTTIFG, UCSTPIFG, UCRXIFG0, UCTXIFG0, UCRXIFG1, UCTXIFG1, UCRXIFG2, UCTXIFG2, UCRXIFG3, UCTXIFG3, UCCNTIFG, UCBIT9IFG, UCCLTOIFG (I ² C mode) (UCB0IV) | Maskable | FFEAh | 53 |
| ADC | ADCIFG0, ADCINIFG, ADCLOIFG, ADCHIIFG, ADCTOVIFG, ADCOVIFG (ADCIV) | Maskable | FFE8h | 52 |
| P1 | P1IFG.0 to P1IFG.7 (P1IV) | Maskable | FFE6h | 51 |
| P2 | P2IFG.0 to P2IFG.7 (P2IV) ⁽¹⁾ | Maskable | FFE4h | 50 |
| eCOMP | CPIIFG, CPIFG (CPIV) | Maskable | FFE2h | 49 |
| Reserved | Reserved | Maskable | FFE0h to FF88h | |

(1) P2.0, P2.1, P2.6, and P2.7 support both pin and software interrupts. Others ports support software interrupts only.

Table 6-2. Interrupt Sources, Flags, and Vectors (continued)

| INTERRUPT SOURCE | INTERRUPT FLAG | SYSTEM INTERRUPT | WORD ADDRESS | PRIORITY |
|------------------|------------------|------------------|--------------|----------|
| Signatures | BSL Signature 2 | | 0FF86h | |
| | BSL Signature 1 | | 0FF84h | |
| | JTAG Signature 2 | | 0FF82h | |
| | JTAG Signature 1 | | 0FF80h | |

6.5 Memory Organization

Table 6-3 summarizes the memory map of the MSP430FR231x MCUs.

Table 6-3. Memory Organization

| | ACCESS | MSP430FR2311 | MSP430FR2310 |
|--|---|--|---|
| Memory (FRAM) Main: interrupt vectors and signatures Main: code memory | Read/Write (Optional Write Protect) ⁽¹⁾ | 3.75KB FFFFh to FF80h FFFFh to F100h | 2KB FFFFh to FF80h FFFFh to F800h |
| RAM | Read/Write | 1KB 23FFh to 2000h | 1KB 23FFh to 2000h |
| Bootloader (BSL1) Memory (ROM) (TI Internal Use) | Read only | 2KB 17FFh to 1000h | 2KB 17FFh to 1000h |
| Bootloader (BSL2) Memory (ROM) (TI Internal Use) | Read only | 1KB FFFFFFh to FFC00h | 1KB FFFFFFh to FFC00h |
| Peripherals | Read/Write | 4KB 0FFFh to 0000h | 4KB 0FFFh to 0000h |

(1) The Program FRAM can be write protected by setting the PFWP bit in the SYSCFG0 register. See the *System Resets, Interrupts, and Operating Modes, System Control Module (SYS)* chapter in the *MSP430FR4xx and MSP430FR2xx Family User's Guide* for more details

6.6 Bootloader (BSL)

The BSL lets users program the FRAM or RAM using a UART or I²C serial interface. Access to the device memory through the BSL is protected by a user-defined password. Use of the BSL requires four pins (see Table 6-4 and Table 6-5). BSL entry requires a specific entry sequence on the $\overline{\text{RST}}/\text{NMI}/\text{SBWTDIO}$ and $\text{TEST}/\text{SBWTCK}$ pins.

This device supports blank device detection to automatically invoke the BSL and skip the special entry sequence, which saves time and simplifies onboard programming. For complete description of the features of the BSL and its implementation, see *MSP430 FRAM Device Bootloader (BSL) User's Guide*.

Table 6-4. UART BSL Pin Requirements and Functions

| DEVICE SIGNAL | BSL FUNCTION |
|---|-----------------------|
| $\overline{\text{RST}}/\text{NMI}/\text{SBWTDIO}$ | Entry sequence signal |
| $\text{TEST}/\text{SBWTCK}$ | Entry sequence signal |
| P1.7 | Data transmit |
| P1.6 | Data receive |
| V _{CC} | Power supply |
| V _{SS} | Ground supply |

Table 6-5. I²C BSL Pin Requirements and Functions

| DEVICE SIGNAL | BSL FUNCTION |
|---|---------------------------|
| $\overline{\text{RST}}/\text{NMI}/\text{SBWTDIO}$ | Entry sequence signal |
| TEST/SBWTCCK | Entry sequence signal |
| P1.2 | Data receive and transmit |
| P1.3 | Clock |
| V _{CC} | Power supply |
| VSS | Ground supply |

6.7 JTAG Standard Interface

The MSP430 family supports the standard JTAG interface which requires four signals for sending and receiving data. The JTAG signals are shared with general-purpose I/O. The TEST/SBWTCCK pin enables the JTAG signals. In addition to these signals, the $\overline{\text{RST}}/\text{NMI}/\text{SBWTDIO}$ pin interfaces with MSP430 development tools and device programmers. Table 6-6 lists the JTAG pin requirements. For further details on interfacing to development tools and device programmers, see the *MSP430 Hardware Tools User's Guide*.

Table 6-6. JTAG Pin Requirements and Function

| DEVICE SIGNAL | DIRECTION | JTAG FUNCTION |
|---|-----------|--------------------------------|
| P1.4/UCA0STE/TCK/OA0+/A4 | IN | JTAG clock input |
| P1.5/UCA0CLK/TMS/TRI00/A5 | IN | JTAG state control |
| P1.6/UCA0RXD/UCA0SOMI/TB0.1/TDI/TCLK/TRI0-/A6 | IN | JTAG data input and TCLK input |
| P1.7/UCA0TXD/UCA0SIMO/TB0.2/TDO/TRI0+/A7/VREF+ | OUT | JTAG data output |
| TEST/SBWTCCK | IN | Enable JTAG pins |
| $\overline{\text{RST}}/\text{NMI}/\text{SBWTDIO}$ | IN | External reset |
| V _{CC} | | Power supply |
| VSS | | Ground supply |

6.8 Spy-Bi-Wire Interface (SBW)

The MSP430 family supports the 2-wire Spy-Bi-Wire interface. Spy-Bi-Wire can be used to interface with MSP430 development tools and device programmers. Table 6-7 lists the Spy-Bi-Wire interface pin requirements. For further details on interfacing to development tools and device programmers, see the *MSP430 Hardware Tools User's Guide*.

Table 6-7. Spy-Bi-Wire Pin Requirements and Functions

| DEVICE SIGNAL | DIRECTION | SBW FUNCTION |
|---|-----------|-----------------------------------|
| TEST/SBWTCCK | IN | Spy-Bi-Wire clock input |
| $\overline{\text{RST}}/\text{NMI}/\text{SBWTDIO}$ | IN, OUT | Spy-Bi-Wire data input and output |
| V _{CC} | – | Power supply |
| VSS | – | Ground supply |

6.9 FRAM

The FRAM can be programmed using the JTAG port, Spy-Bi-Wire (SBW), the BSL, or in system by the CPU. Features of the FRAM include:

- Byte and word access capability
- Programmable wait state generation
- Error correction coding (ECC)

6.10 Memory Protection

The device features memory protection of user access authority and write protection include:

- Securing the whole memory map to prevent unauthorized access from JTAG port or BSL, by writing JTAG and BSL signatures using the JTAG port, SBW, the BSL, or in system by the CPU.
- Write protection enabled to prevent unwanted write operation to FRAM contents by setting the control bits with accordingly password in System Configuration register 0. For more detailed information, see the *System Resets, Interrupts, and Operating Modes, System Control Module (SYS)* chapter in the [MSP430FR4xx and MSP430FR2xx Family User's Guide](#).

6.11 Peripherals

Peripherals are connected to the CPU through data, address, and control buses. All peripherals can be handled by using all instructions in the memory map. For complete module description, see the [MSP430FR4xx and MSP430FR2xx Family User's Guide](#).

6.11.1 Power-Management Module (PMM) and On-chip Reference Voltages

The PMM includes an integrated voltage regulator that supplies the core voltage to the device. The PMM also includes supply voltage supervisor (SVS) and brownout protection. The brownout reset circuit (BOR) is implemented to provide the proper internal reset signal to the device during power on and power off. The SVS circuitry detects if the supply voltage drops below a user-selectable safe level. SVS circuitry is available on the primary supply.

The device contains two on-chip reference: 1.5 V for internal reference and 1.2 V for external reference.

The 1.5-V reference is internally connected to ADC channel 13. DVCC is internally connected to ADC channel 15. When DVCC is set as the reference voltage for ADC conversion, the DVCC can be easily represent as [Equation 1](#) by using ADC sampling 1.5-V reference without any external components support.

$$DVCC = (1023 \times 1.5 \text{ V}) \div 1.5\text{-V reference ADC result} \quad (1)$$

The 1.5-V reference is also internally connected to the Comparator built-in DAC as reference voltage. DVCC is internally connected to another source of DAC reference, and both are controlled by the CPDACREFS bit. For more detailed information, see the *Enhanced Comparator (eCOMP)* chapter of the [MSP430FR4xx and MSP430FR2xx Family User's Guide](#).

A 1.2-V reference voltage can be buffered, when EXTREFEN = 1 on PMMCTL2 register, and it can be output to P1.7/UCA0TXD/UCA0SIMO/TB0.2/TDO/TRI0+/A7/VREF+ , meanwhile the ADC channel 7 can also be selected to monitor this voltage. For more detailed information, see the [MSP430FR4xx and MSP430FR2xx Family User's Guide](#).

6.11.2 Clock System (CS) and Clock Distribution

The clock system includes a 32-kHz low-frequency oscillator (XT1 low frequency) or up to a 16-MHz high-frequency crystal oscillator (XT1 high frequency), an internal very low-power low-frequency oscillator (VLO), an integrated 32-kHz RC oscillator (REFO), an integrated internal digitally controlled oscillator (DCO) that can use frequency-locked loop (FLL) locking with internal or external 32-kHz reference clock, and on-chip asynchronous high-speed clock (MODOSC). The clock system is designed to target cost-effective designs with minimal external components. A fail-safe mechanism is designed for XT1. The clock system module offers the following clock signals.

- Main Clock (MCLK): system clock used by the CPU and all relevant peripherals accessed by the bus. All clock sources except MODOSC can be selected as the source with a predivider of 1, 2, 4, 8, 16, 32, 64, or 128.
- Sub-Main Clock (SMCLK): subsystem clock used by the peripheral modules. SMCLK derives from the MCLK with a predivider of 1, 2, 4, or 8. This means SMCLK is always equal to or less than MCLK.
- Auxiliary Clock (ACLK): derived from the external XT1 clock or internal REFO clock up to 40 kHz.

All peripherals may have one or several clock sources depending on specific functionality. [Table 6-8](#) and [Table 6-9](#) show the clock distribution used in this device.

Table 6-8. Clock Distribution

| | CLOCK SOURCE SELECT BITS ⁽¹⁾ | MCLK | SMCLK | ACLK | MODCLK | VLOCLK | EXTERNAL PIN |
|-----------------|---|--------------|--------------------|--------------------|------------|-------------|-------------------|
| Frequency Range | | DC to 16 MHz | DC to 16 MHz | DC to 40 kHz | 5 MHz ±10% | 10 kHz ±50% | – |
| CPU | N/A | Default | – | – | – | – | – |
| FRAM | N/A | Default | – | – | – | – | – |
| RAM | N/A | Default | – | – | – | – | – |
| CRC | N/A | Default | – | – | – | – | – |
| I/O | N/A | Default | – | – | – | – | – |
| TB0 | TBSSEL | – | 10b | 01b | – | – | 00b (TB0CLK pin) |
| TB1 | TBSSEL | – | 10b | 01b | – | – | 00b (TB1CLK pin) |
| eUSCI_A0 | UCSSEL | – | 10b or 11b | 01b | – | – | 00b (UCA0CLK pin) |
| eUSCI_B0 | UCSSEL | – | 10b or 11b | 01b | – | – | 00b (UCB0CLK pin) |
| WDT | WDTSEL | – | 00b | 01b | – | 10b | – |
| ADC | ADCSSEL | – | 10b or 11b | 01b | 00b | – | – |
| RTC | RTCSS | – | 01b ⁽²⁾ | 01b ⁽²⁾ | – | 11b | – |

(1) N/A = not applicable

(2) Controlled by the RTCCKSEL bit in the SYSCFG2 register.

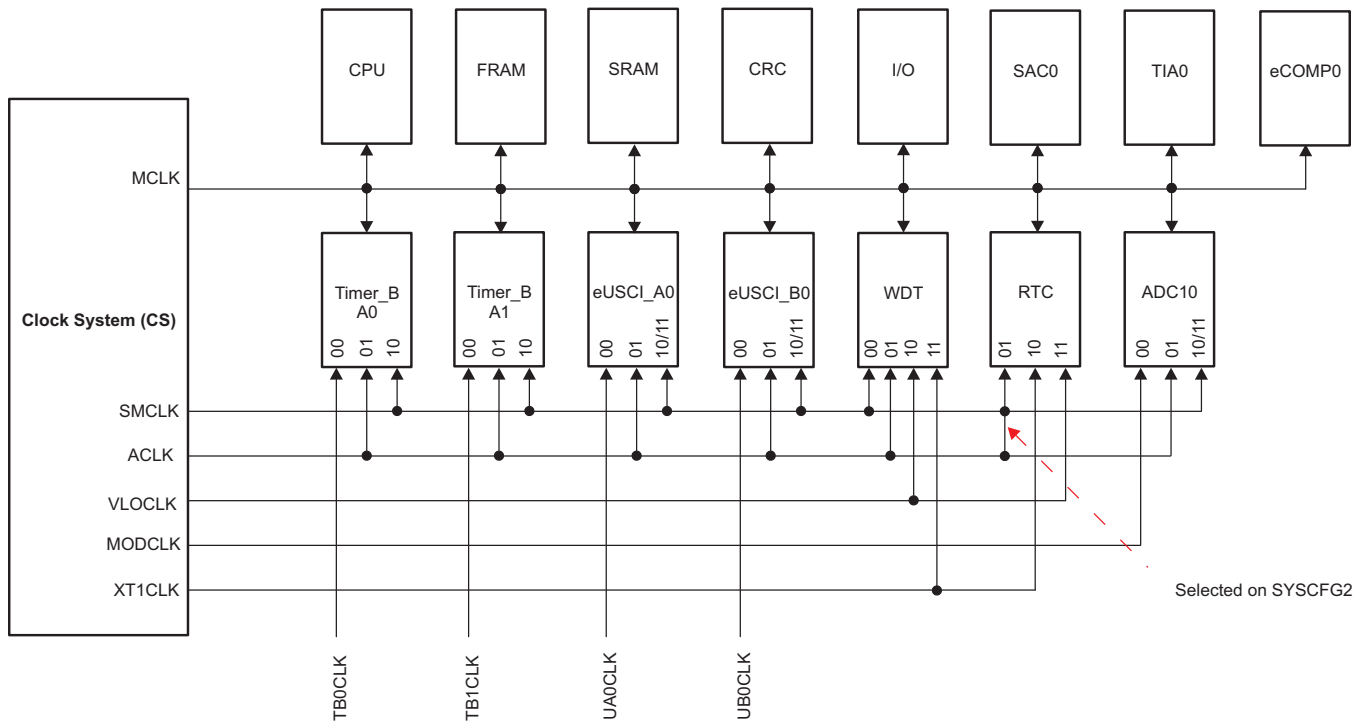

Figure 6-1. Clock Distribution Block Diagram

Table 6-9. XTCLK Distribution

| OPERATION MODE | CLOCK SOURCE SELECT BITS | XTHFCLK | XTLFCLK | XTLFCLK (LPMx.5) |
|----------------|--------------------------|------------|------------|------------------|
| | | AM TO LPM0 | AM TO LPM3 | AM TO LPM3.5 |
| MCLK | SEMS | 10b | 10b | 10b |
| SMCLK | SEMS | 10b | 10b | 10b |
| REFO | SELREF | 0b | 0b | 0b |
| ACLK | SELA | 0b | 0b | 0b |
| RTC | RTCSS | – | 10b | 10b |

6.11.3 General-Purpose Input/Output Port (I/O)

There are up to 16 I/O ports implemented.

- P1 and P2 are full 8-bit ports.
- All individual I/O bits are independently programmable.
- Any combination of input and output is possible for P1 and P2. All inputs of P1 and four inputs of P2 (P2.0, P2.1, P2.6, P2.7) can be configured for interrupt input.
- Programmable pullup or pulldown on all ports.
- All inputs of P1 and four inputs of P2 (P2.0, P2.1, P2.6, P2.7) can be configured for edge-selectable interrupt and for LPM3.5, LPM4, and LPM4.5 wake-up input capability.
- Read and write access to port-control registers is supported by all instructions.
- Ports can be accessed byte-wise or word-wise in pairs.
- Capacitive Touch I/O functionality is supported on all pins.

NOTE

Configuration of digital I/Os after BOR reset

To prevent any cross currents during start-up of the device, all port pins are high-impedance with Schmitt triggers and module functions disabled. To enable the I/O functions after a BOR reset, the ports must be configured first and then the LOCKLPM5 bit must be cleared. For details, see the *Configuration After Reset* section in the *Digital I/O* chapter of the [MSP430FR4xx and MSP430FR2xx Family User's Guide](#).

6.11.4 Watchdog Timer (WDT)

The primary function of the WDT module is to perform a controlled system restart after a software problem occurs. If the selected time interval expires, a system reset is generated. If the watchdog function is not needed in an application, the module can be configured as interval timer and can generate interrupts at selected time intervals.

Table 6-10. WDT Clocks

| WDTSEL | NORMAL OPERATION (WATCHDOG AND INTERVAL TIMER MODE) |
|--------|---|
| 00 | SMCLK |
| 01 | ACLK |
| 10 | VLOCLK |
| 11 | Reserved |

6.11.5 System Module (SYS)

The SYS module handles many of the system functions within the device. These system functions include power-on reset (POR) and power-up clear (PUC) handling, NMI source selection and management, reset interrupt vector generators, bootloader entry mechanisms, and configuration management (device descriptors) (see [Table 6-11](#)). SYS also includes a data exchange mechanism through SBW called a JTAG mailbox that can be used in the application.

Table 6-11. System Module Interrupt Vector Registers

| INTERRUPT VECTOR REGISTER | ADDRESS | INTERRUPT EVENT | VALUE | PRIORITY |
|--|------------|--|------------|----------------------|
| SYSRSTIV, System Reset | 015Eh | No interrupt pending | 00h | |
| | | Brownout (BOR) | 02h | Highest |
| | | RSTIFG RST/NMI (BOR) | 04h | |
| | | PMMSWBOR software BOR (BOR) | 06h | |
| | | LPMx.5 wakeup (BOR) | 08h | |
| | | Security violation (BOR) | 0Ah | |
| | | Reserved | 0Ch | |
| | | SVSHIFG SVSH event (BOR) | 0Eh | |
| | | Reserved | 10h | |
| | | Reserved | 12h | |
| | | PMMSWPOR software POR (POR) | 14h | |
| | | WDTIFG watchdog time-out (PUC) | 16h | |
| | | WDTPW password violation (PUC) | 18h | |
| | | FRCTLPW password violation (PUC) | 1Ah | |
| | | Uncorrectable FRAM bit error detection | 1Ch | |
| | | Peripheral area fetch (PUC) | 1Eh | |
| | | PMMPW PMM password violation (PUC) | 20h | |
| | | Reserved | 22h | |
| | | FLL unlock (PUC) | 24h | |
| Reserved | 26h to 3Eh | Lowest | | |
| SYSSNIV, System NMI | 015Ch | No interrupt pending | 00h | |
| | | SVS low-power reset entry | 02h | Highest |
| | | Uncorrectable FRAM bit error detection | 04h | |
| | | Reserved | 06h | |
| | | Reserved | 08h | |
| | | Reserved | 0Ah | |
| | | Reserved | 0Ch | |
| | | Reserved | 0Eh | |
| | | Reserved | 10h | |
| | | VMAIFG Vacant memory access | 12h | |
| | | JMBINIFG JTAG mailbox input | 14h | |
| | | JMBOUTIFG JTAG mailbox output | 16h | |
| | | Correctable FRAM bit error detection | 18h | |
| | | Reserved | 1Ah to 1Eh | Lowest |
| | | SYSUNIV, User NMI | 015Ah | No interrupt pending |
| NMIIFG NMI pin or SVS _H event | 02h | | | Highest |
| OFIFG oscillator fault | 04h | | | |
| Reserved | 06h to 1Eh | | | Lowest |

6.11.6 Cyclic Redundancy Check (CRC)

The 16-bit cyclic redundancy check (CRC) module produces a signature based on a sequence of data values and can be used for data checking purposes. The CRC generation polynomial is compliant with CRC-16-CCITT standard of $x^{16} + x^{12} + x^5 + 1$.

6.11.7 Enhanced Universal Serial Communication Interface (eUSCI_A0, eUSCI_B0)

The eUSCI modules are used for serial data communications. The eUSCI_A module supports either UART or SPI communications. The eUSCI_B module supports either SPI or I²C communications. In addition, the eUSCI_A module supports automatic baud-rate detection and IrDA.. The eUSCI_B module is connected either from P1 port or P2 port, it can be selected from the USCIBRMAP bit of the SYSCFG2 register (see [Table 6-12](#)).

Table 6-12. eUSCI Pin Configurations

| | PIN | UART | SPI |
|----------|---------------------------|-----------------------|------------|
| eUSCI_A0 | P1.7 | TXD | SIMO |
| | P1.6 | RXD | SOMI |
| | P1.5 | – | SCLK |
| | P1.4 | – | STE |
| eUSCI_B0 | PIN (USCIBRMP = 0) | I²C | SPI |
| | P1.0 | – | STE |
| | P1.1 | – | SCLK |
| | P1.2 | SDA | SIMO |
| | P1.3 | SCL | SOMI |
| | PIN (USCIBRMP = 1) | I²C | SPI |
| | P2.2 | – | STE |
| | P2.3 | – | SCLK |
| | P2.4 | SDA | SIMO |
| | P2.5 | SCL | SOMI |

6.11.8 Timers (Timer0_B3, Timer1_B3)

The Timer0_B3 and Timer1_B3 modules are 16-bit timers and counters with three capture/compare registers each. Each can support multiple captures or compares, PWM outputs, and interval timing (see [Table 6-13](#) and [Table 6-14](#)). Each has extensive interrupt capabilities. Interrupts may be generated from the counter on overflow conditions and from each of the capture/compare registers. The CCR0 registers on TB0 and TB1 are not externally connected and can be used only for hardware period timing and interrupt generation. In Up mode, they can set the overflow value of the counter.

The interconnection of Timer0_B3 and Timer1_B3 can modulate the eUSCI_A pin of UCA0TXD/UCA0SIMO in either ASK or FSK mode, with which a user can easily acquire a modulated infrared command for directly driving an external IR diode (see [Figure 6-2](#)). The IR functions are fully controlled by the SYS configuration registers including IREN (enable), IRPSEL (polarity select), IRMSEL (mode select), IRDSSEL (data select), and IRDATA (data) bits. For more information, see the *System Resets, Interrupts, and Operating Modes, System Control Module (SYS)* chapter in the [MSP430FR4xx and MSP430FR2xx Family User's Guide](#).

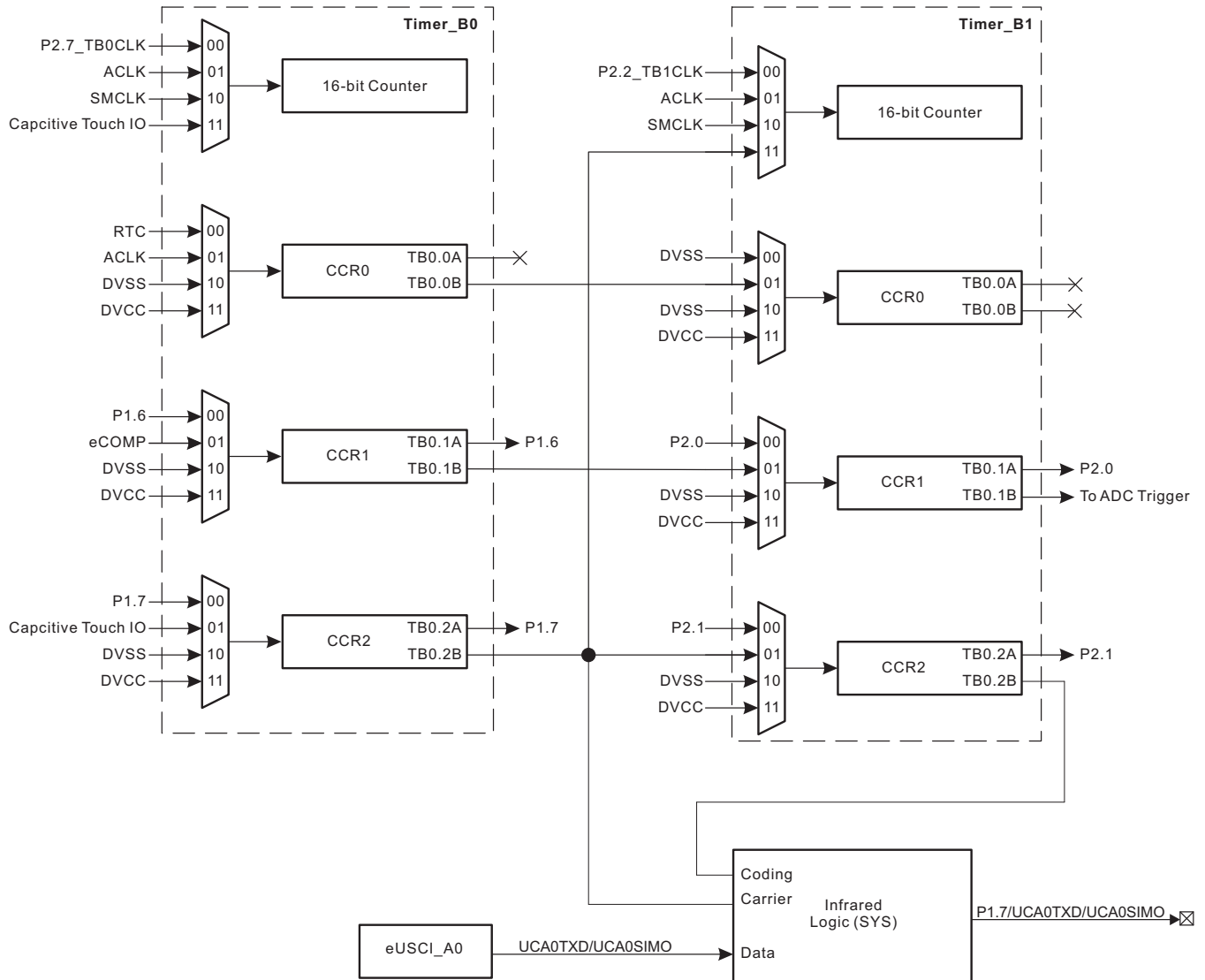

Figure 6-2. Timer_B Connections

Table 6-13. Timer0_B3 Signal Connections

| PORT PIN | DEVICE INPUT SIGNAL | MODULE INPUT NAME | MODULE BLOCK | MODULE OUTPUT SIGNAL | DEVICE OUTPUT SIGNAL |
|----------|--------------------------------------|-------------------|--------------|----------------------|---|
| P2.7 | TB0CLK | TBCLK | Timer | N/A | |
| | ACLK (internal) | ACLK | | | |
| | SMCLK (internal) | SMCLK | | | |
| | From Capacitive Touch I/O (internal) | INCLK | | | |
| | From RTC (internal) | CCI0A | | | |
| | ACLK (internal) | CCI0B | CCR0 | TB0 | Timer1_B3 CCI0B input |
| | DVSS | GND | | | |
| | DVCC | V _{CC} | | | |
| | | | | | |
| P1.6 | TB0.1 | CCI1A | CCR1 | TB1 | TB0.1 |
| | From eCOMP (internal) | CCI1B | | | Timer1_B3 CCI1B input |
| | DVSS | GND | | | |
| | DVCC | V _{CC} | | | |
| P1.7 | TB0.2 | CCI2A | CCR2 | TB2 | TB0.2 |
| | From Capacitive Touch I/O (internal) | CCI2B | | | Timer1_B3 INCLK Timer1_B3 CCI2B input, IR input |
| | DVSS | GND | | | |
| | DVCC | V _{CC} | | | |

Table 6-14. Timer1_B3 Signal Connections

| PORT PIN | DEVICE INPUT SIGNAL | MODULE INPUT NAME | MODULE BLOCK | MODULE OUTPUT SIGNAL | DEVICE OUTPUT SIGNAL |
|----------|-----------------------------------|-------------------|--------------|----------------------|----------------------|
| P2.2 | TB1CLK | TBCLK | Timer | N/A | |
| | ACLK (internal) | ACLK | | | |
| | SMCLK (internal) | SMCLK | | | |
| | Timer0_B3 CCR2B output (internal) | INCLK | | | |
| | DVSS | CCI0A | | | |
| | Timer0_B3 CCR0B output (internal) | CCI0B | CCR0 | TB0 | |
| | DVSS | GND | | | |
| | DVCC | V _{CC} | | | |
| | | | | | |
| P2.0 | TB1.1 | CCI1A | CCR1 | TB1 | TB1.1 |
| | Timer0_B3 CCR1B output (internal) | CCI1B | | | To ADC trigger |
| | DVSS | GND | | | |
| | DVCC | V _{CC} | | | |
| P2.1 | TB1.2 | CCI2A | CCR2 | TB2 | TB1.2 |
| | Timer0_B3 CCR2B output (internal) | CCI2B | | | IR input |
| | DVSS | GND | | | |
| | DVCC | V _{CC} | | | |

The Timer_B module includes a feature that puts all Timer_B outputs into a high-impedance state when the selected source is triggered. The source can be selected from an external pin or an internal signal, and it is controlled by TBxTRG in SYS. For more information, see the *System Resets, Interrupts, and Operating Modes, System Control Module (SYS)* chapter in the *MSP430FR4xx and MSP430FR2xx Family User's Guide*.

Table 6-15 lists the Timer_B high-impedance trigger source selections.

Table 6-15. TBxOUTH

| TBxTRGSEL | TBxOUTH TRIGGER SOURCE SELECTION | Timer_B PAD OUTPUT HIGH IMPEDANCE |
|---------------|----------------------------------|-----------------------------------|
| TB0TRGSEL = 0 | eCOMP0 output (internal) | P1.6, P1.7 |
| TB0TRGSEL = 1 | P1.2 | |
| TB1TRGSEL = 0 | eCOMP0 output (internal) | P2.0, P2.1 |
| TB1TRGSEL = 1 | P2.3 | |

6.11.9 Backup Memory (BAKMEM)

The BAKMEM supports data retention during LPM3.5 mode. This device provides up to 32 bytes that are retained during LPM3.5.

6.11.10 Real-Time Clock (RTC) Counter

The RTC counter is a 16-bit modulo counter that is functional in AM, LPM0, LPM3, LPM4, and LPM3.5. This module may periodically wake up the CPU from LPM0, LPM3, LPM4, and LPM3.5 based on timing from a low-power clock source such as the XT1, ACLK, or VLO clocks. In AM, RTC can be driven by SMCLK to generate high-frequency timing events and interrupts. ACLK and SMCLK both can source to the RTC, however only one of them can be selected simultaneously. The RTC overflow events trigger:

- Timer0_B3 CCI0A
- ADC conversion trigger when ADCSHSx bits are set as 01b

6.11.11 10-Bit Analog-to-Digital Converter (ADC)

The 10-bit ADC module supports fast 10-bit analog-to-digital conversions with single-ended input. The module implements a 10-bit SAR core, sample select control, a reference generator, and a conversion result buffer. A window comparator with lower and upper limits allows CPU-independent result monitoring with three window comparator interrupt flags.

The ADC supports 10 external inputs and 4 internal inputs (see [Table 6-16](#)).

Table 6-16. ADC Channel Connections

| ADCINCHx | ADC CHANNELS | EXTERNAL PIN |
|----------|----------------------------|--------------|
| 0 | A0/V _{ref} + | P1.0 |
| 1 | A1 | P1.1 |
| 2 | A2/V _{ref} - | P1.2 |
| 3 | A3 | P1.3 |
| 4 | A4 | P1.4 |
| 5 | A5 | P1.5 |
| 6 | A6 | P1.6 |
| 7 | A7 ⁽¹⁾ | P1.7 |
| 8 | Not used | N/A |
| 9 | Not used | N/A |
| 10 | Not used | N/A |
| 11 | Not used | N/A |
| 12 | On-chip temperature sensor | N/A |
| 13 | Reference voltage (1.5 V) | N/A |
| 14 | DVSS | N/A |
| 15 | DVCC | N/A |

(1) When A7 is used, the PMM 1.2-V reference voltage can be output to this pin by setting the PMM control register. The 1.2-V voltage can be measured by the A7 channel.

The analog-to-digital conversion can be started by software or a hardware trigger. [Table 6-17](#) lists the trigger sources that are available.

Table 6-17. ADC Trigger Signal Connections

| ADC SHSx | | TRIGGER SOURCE |
|----------|---------|------------------------------|
| BINARY | DECIMAL | |
| 00 | 0 | ADCSC bit (software trigger) |
| 01 | 1 | RTC event |
| 10 | 2 | TB1.1B |
| 11 | 3 | eCOMP0 COUT |

6.11.12 eCOMP0

The enhanced comparator is an analog voltage comparator with built-in 6-bit DAC as an internal voltage reference. The integrated 6-bit DAC can be set up to 64 steps for comparator reference voltage. This module has 4-level programmable hysteresis and configurable power modes, high power or low power.

eCOMP0 supports external inputs and internal inputs (see [Table 6-18](#)) and outputs (see [Table 6-19](#)).

Table 6-18. eCOMP0 Input Channel Connections

| CPPSEL, CPNSEL | eCOMP0 CHANNELS | EXTERNAL OR INTERNAL CONNECTION |
|----------------|-----------------|---|
| BINARY | | |
| 000 | C0 | P1.0 |
| 001 | C1 | P1.1 |
| 010 | Not used | N/A |
| 011 | Not used | N/A |
| 100 | C4 | SAC0, OA00 on positive port TIA0, TRI00 on negative port |
| 101 | Not used | N/A |
| 110 | C6 | Built-in 6-bit DAC |

Table 6-19. eCOMP0 Output Channel Connections

| eCOMP0 OUT | EXTERNAL PIN OUT, MODULE |
|------------|---|
| 1 | P2.0 |
| 2 | TB0.1B, TB0 (TB0OUTH), TB1 (TB1OUTH), ADC |

6.11.13 SAC0

The Smart Analog Combo (SAC) integrates a high-performance low-power operational amplifier. SAC-L1 is integrated in FR231x. SAC-L1 supports only a general-purpose amplifier. For more information, see the *Smart Analog Combo (SAC)* chapter in the *MSP430FR4xx and MSP430FR2xx Family User's Guide*.

SAC0 supports external inputs and internal inputs (see [Table 6-20](#) and [Table 6-21](#)).

Table 6-20. SAC0 Positive Input Channel Connections

| PSEL | SAC0 CHANNELS | EXTERNAL PIN OUT, MODULE |
|------|------------------------------|--------------------------|
| 00 | SAC0, OA0 positive channel 1 | P1.4 |
| 10 | SAC0, OA0 positive channel 2 | TRI00 |

Table 6-21. SAC0 Negative Input Channel Connections

| NSEL | SAC0 CHANNELS | EXTERNAL PIN OUT, MODULE |
|------|------------------------------|--------------------------|
| 00 | SAC0, OA0 negative channel 1 | P1.2 |
| 10 | Not used | N/A |

6.11.14 TIA0

The Transimpedance Amplifier (TIA) is a high-performance low-power amplifier with rail-to-rail output. This module is an amplifier that converts current to voltage. It has programmable power modes: high power or low power. For more information, see the *Transimpedance Amplifier (TIA)* chapter in the [MSP430FR4xx and MSP430FR2xx Family User's Guide](#).

The FR231x device in the TSSOP-16 package supports a dedicated low-leakage pad for TIA negative input to support low-leakage performance. In other packages (TSSOP-20 and VQFN-16), the TIA negative port is shared with a GPIO to support the transimpedance amplifier function. For more information, see [Section 4](#) and [Table 5-25](#).

The TIA supports external input (see [Table 6-22](#) and [Section 4](#)).

Table 6-22. TIA Input Channel Connections

| TRIPSEL | TIA0 CHANNELS | EXTERNAL PIN OUT, MODULE |
|---------|----------------|--------------------------|
| 00 | Positive input | P1.7 |
| 01 | Not used | N/A |
| 10 | Not used | N/A |
| 11 | Not used | N/A |

6.11.15 eCOMP0, SAC0, TIA0, and ADC in SOC Interconnection

Figure 6-3 shows how the high-performance analog modules are internally connected.

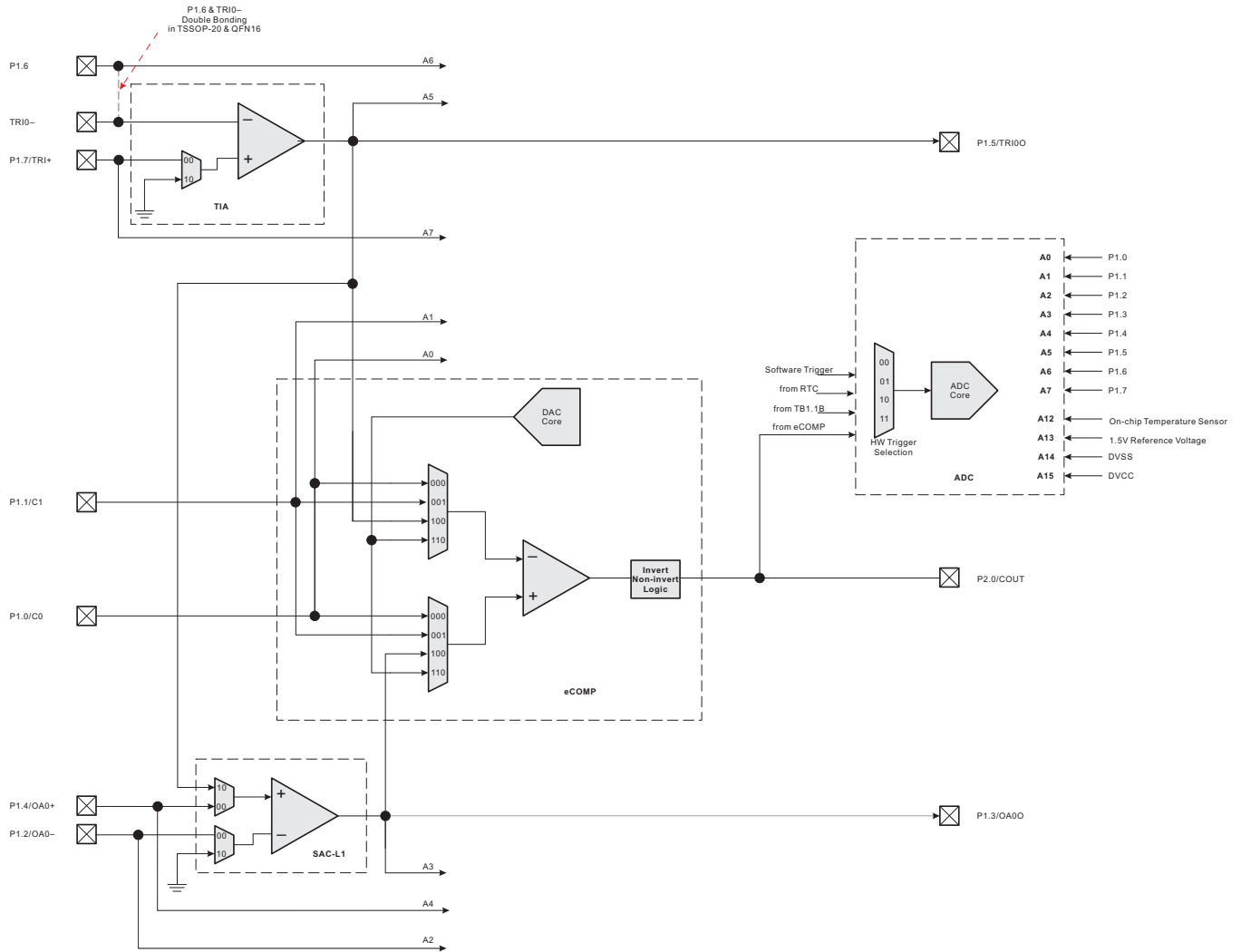

Figure 6-3. High-Performance Analog SOC Interconnection

Figure 6-4 shows how the analog modules can be connected internally.

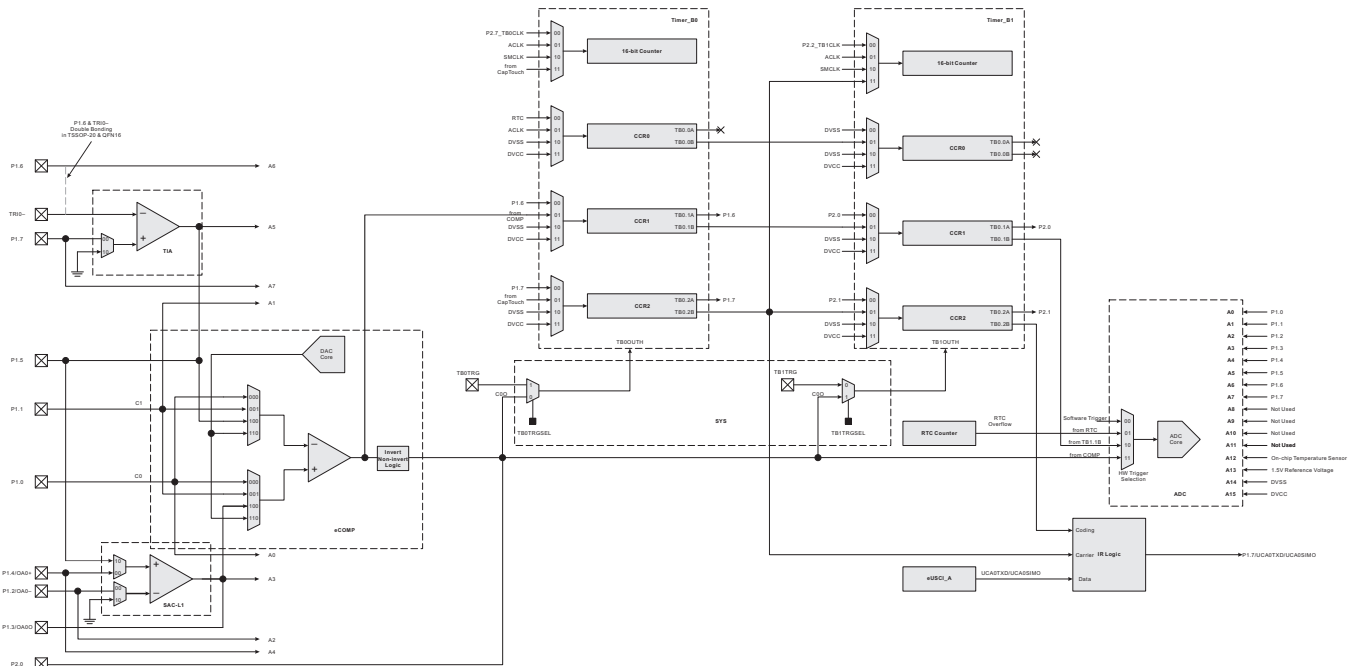

Figure 6-4. SOC Interconnection

6.11.16 Embedded Emulation Module (EEM)

The EEM supports real-time in-system debugging. The EEM on these devices has the following features:

- Three hardware triggers or breakpoints on memory access
- One hardware trigger or breakpoint on CPU register write access
- Up to four hardware triggers that can be combined to form complex triggers or breakpoints
- One cycle counter
- Clock control on module level

6.11.17 Peripheral File Map

Table 6-23 lists the base address of the registers for each peripheral. Table 6-24 through Table 6-42 list all of the available registers for each peripheral and their address offsets.

Table 6-23. Peripherals Summary

| MODULE NAME | BASE ADDRESS | SIZE |
|---------------------------------------|--------------|-------|
| Special Functions (see Table 6-24) | 0100h | 0010h |
| PMM (see Table 6-25) | 0120h | 0020h |
| SYS (see Table 6-26) | 0140h | 0040h |
| CS (see Table 6-27) | 0180h | 0020h |
| FRAM (see Table 6-28) | 01A0h | 0010h |
| CRC (see Table 6-29) | 01C0h | 0008h |
| WDT (see Table 6-30) | 01CCh | 0002h |
| Port P1, P2 (see Table 6-31) | 0200h | 0020h |
| Capacitive Touch I/O (see Table 6-32) | 02E0h | 0010h |
| RTC (see Table 6-33) | 0300h | 0010h |
| Timer0_B3 (see Table 6-34) | 0380h | 0030h |
| Timer1_B3 (see Table 6-35) | 03C0h | 0030h |
| eUSCI_A0 (see Table 6-36) | 0500h | 0020h |
| eUSCI_B0 (see Table 6-37) | 0540h | 0030h |
| Backup Memory (see Table 6-38) | 0660h | 0020h |
| ADC (see Table 6-39) | 0700h | 0040h |
| eCOMP0 (see Table 6-40) | 08E0h | 0020h |
| SAC0 (see Table 6-41) | 0C80h | 0010h |
| TIA0 (see Table 6-42) | 0F00h | 0010h |

Table 6-24. Special Function Registers (Base Address: 0100h)

| REGISTER DESCRIPTION | REGISTER | OFFSET |
|-----------------------|----------|--------|
| SFR interrupt enable | SFRIE1 | 00h |
| SFR interrupt flag | SFRIFG1 | 02h |
| SFR reset pin control | SFRRPCR | 04h |

Table 6-25. PMM Registers (Base Address: 0120h)

| REGISTER DESCRIPTION | REGISTER | OFFSET |
|----------------------|----------|--------|
| PMM control 0 | PMMCTL0 | 00h |
| PMM control 1 | PMMCTL1 | 02h |
| PMM control 2 | PMMCTL2 | 04h |
| PMM interrupt flags | PMMIFG | 0Ah |
| PM5 control 0 | PM5CTL0 | 10h |

Table 6-26. SYS Registers (Base Address: 0140h)

| REGISTER DESCRIPTION | REGISTER | OFFSET |
|-------------------------------|----------|--------|
| System control | SYSCTL | 00h |
| Bootloader configuration area | SYSBSLC | 02h |
| JTAG mailbox control | SYSJMBC | 06h |
| JTAG mailbox input 0 | SYSJMBI0 | 08h |
| JTAG mailbox input 1 | SYSJMBI1 | 0Ah |
| JTAG mailbox output 0 | SYSJMBO0 | 0Ch |

Table 6-26. SYS Registers (Base Address: 0140h) (continued)

| REGISTER DESCRIPTION | REGISTER | OFFSET |
|-----------------------------|----------|--------|
| JTAG mailbox output 1 | SYSJMBO1 | 0Eh |
| User NMI vector generator | SYSUNIV | 1Ah |
| System NMI vector generator | SYSSNIV | 1Ch |
| Reset vector generator | SYSRSTIV | 1Eh |
| System configuration 0 | SYSCFG0 | 20h |
| System configuration 1 | SYSCFG1 | 22h |
| System configuration 2 | SYSCFG2 | 24h |

Table 6-27. CS Registers (Base Address: 0180h)

| REGISTER DESCRIPTION | REGISTER | OFFSET |
|----------------------|----------|--------|
| CS control 0 | CSCTL0 | 00h |
| CS control 1 | CSCTL1 | 02h |
| CS control 2 | CSCTL2 | 04h |
| CS control 3 | CSCTL3 | 06h |
| CS control 4 | CSCTL4 | 08h |
| CS control 5 | CSCTL5 | 0Ah |
| CS control 6 | CSCTL6 | 0Ch |
| CS control 7 | CSCTL7 | 0Eh |
| CS control 8 | CSCTL8 | 10h |

Table 6-28. FRAM Registers (Base Address: 01A0h)

| REGISTER DESCRIPTION | REGISTER | OFFSET |
|----------------------|----------|--------|
| FRAM control 0 | FRCTL0 | 00h |
| General control 0 | GCCTL0 | 04h |
| General control 1 | GCCTL1 | 06h |

Table 6-29. CRC Registers (Base Address: 01C0h)

| REGISTER DESCRIPTION | REGISTER | OFFSET |
|-------------------------------|-----------|--------|
| CRC data input | CRC16DI | 00h |
| CRC data input reverse byte | CRCDIRB | 02h |
| CRC initialization and result | CRCINIRES | 04h |
| CRC result reverse byte | CRCRESR | 06h |

Table 6-30. WDT Registers (Base Address: 01CCh)

| REGISTER DESCRIPTION | REGISTER | OFFSET |
|------------------------|----------|--------|
| Watchdog timer control | WDTCTL | 00h |

Table 6-31. Port P1, P2 Registers (Base Address: 0200h)

| REGISTER DESCRIPTION | REGISTER | OFFSET |
|-------------------------------|----------|--------|
| Port P1 input | P1IN | 00h |
| Port P1 output | P1OUT | 02h |
| Port P1 direction | P1DIR | 04h |
| Port P1 pulling enable | P1REN | 06h |
| Port P1 selection 0 | P1SEL0 | 0Ah |
| Port P1 selection 1 | P1SEL1 | 0Ch |
| Port P1 interrupt vector word | P1IV | 0Eh |

Table 6-31. Port P1, P2 Registers (Base Address: 0200h) (continued)

| REGISTER DESCRIPTION | REGISTER | OFFSET |
|-------------------------------|----------|--------|
| Port P1 complement selection | P1SELC | 16h |
| Port P1 interrupt edge select | P1IES | 18h |
| Port P1 interrupt enable | P1IE | 1Ah |
| Port P1 interrupt flag | P1IFG | 1Ch |
| Port P2 input | P2IN | 01h |
| Port P2 output | P2OUT | 03h |
| Port P2 direction | P2DIR | 05h |
| Port P2 pulling enable | P2REN | 07h |
| Port P2 selection 0 | P2SEL0 | 0Bh |
| Port P2 selection 1 | P2SEL1 | 0Dh |
| Port P2 complement selection | P2SELC | 17h |
| Port P2 interrupt vector word | P2IV | 1Eh |
| Port P2 interrupt edge select | P2IES | 19h |
| Port P2 interrupt enable | P2IE | 1Bh |
| Port P2 interrupt flag | P2IFG | 1Dh |

Table 6-32. Capacitive Touch I/O Registers (Base Address: 02E0h)

| REGISTER DESCRIPTION | REGISTER | OFFSET |
|--------------------------------|-----------|--------|
| Capacitive touch I/O 0 control | CAPIO0CTL | 0Eh |

Table 6-33. RTC Registers (Base Address: 0300h)

| REGISTER DESCRIPTION | REGISTER | OFFSET |
|----------------------|----------|--------|
| RTC control | RTCCTL | 00h |
| RTC interrupt vector | RTCIV | 04h |
| RTC modulo | RTCMOD | 08h |
| RTC counter | RTCCNT | 0Ch |

Table 6-34. Timer0_B3 Registers (Base Address: 0380h)

| REGISTER DESCRIPTION | REGISTER | OFFSET |
|---------------------------|----------|--------|
| TB0 control | TB0CTL | 00h |
| Capture/compare control 0 | TB0CCTL0 | 02h |
| Capture/compare control 1 | TB0CCTL1 | 04h |
| Capture/compare control 2 | TB0CCTL2 | 06h |
| TB0 counter | TB0R | 10h |
| Capture/compare 0 | TB0CCR0 | 12h |
| Capture/compare 1 | TB0CCR1 | 14h |
| Capture/compare 2 | TB0CCR2 | 16h |
| TB0 expansion 0 | TB0EX0 | 20h |
| TB0 interrupt vector | TB0IV | 2Eh |

Table 6-35. Timer1_B3 Registers (Base Address: 03C0h)

| REGISTER DESCRIPTION | REGISTER | OFFSET |
|---------------------------|----------|--------|
| TB1 control | TB1CTL | 00h |
| Capture/compare control 0 | TB1CCTL0 | 02h |
| Capture/compare control 1 | TB1CCTL1 | 04h |
| Capture/compare control 2 | TB1CCTL2 | 06h |

Table 6-35. Timer1_B3 Registers (Base Address: 03C0h) (continued)

| REGISTER DESCRIPTION | REGISTER | OFFSET |
|----------------------|----------|--------|
| TB1 counter | TB1R | 10h |
| Capture/compare 0 | TB1CCR0 | 12h |
| Capture/compare 1 | TB1CCR1 | 14h |
| Capture/compare 2 | TB1CCR2 | 16h |
| TB1 expansion 0 | TB1EX0 | 20h |
| TB1 interrupt vector | TB1IV | 2Eh |

Table 6-36. eUSCI_A0 Registers (Base Address: 0500h)

| REGISTER DESCRIPTION | REGISTER | OFFSET |
|-------------------------------|-------------|--------|
| eUSCI_A control word 0 | UCA0CTLW0 | 00h |
| eUSCI_A control word 1 | UCA0CTLW1 | 02h |
| eUSCI_A control rate 0 | UCA0BR0 | 06h |
| eUSCI_A control rate 1 | UCA0BR1 | 07h |
| eUSCI_A modulation control | UCA0MCTLW | 08h |
| eUSCI_A status | UCA0STAT | 0Ah |
| eUSCI_A receive buffer | UCA0RXBUF | 0Ch |
| eUSCI_A transmit buffer | UCA0TXBUF | 0Eh |
| eUSCI_A LIN control | UCA0ABCTL | 10h |
| eUSCI_A IrDA transmit control | IUCA0IRTCTL | 12h |
| eUSCI_A IrDA receive control | IUCA0IRRCTL | 13h |
| eUSCI_A interrupt enable | UCA0IE | 1Ah |
| eUSCI_A interrupt flags | UCA0IFG | 1Ch |
| eUSCI_A interrupt vector word | UCA0IV | 1Eh |

Table 6-37. eUSCI_B0 Registers (Base Address: 0540h)

| REGISTER DESCRIPTION | REGISTER | OFFSET |
|--------------------------------|-------------|--------|
| eUSCI_B control word 0 | UCB0CTLW0 | 00h |
| eUSCI_B control word 1 | UCB0CTLW1 | 02h |
| eUSCI_B bit rate 0 | UCB0BR0 | 06h |
| eUSCI_B bit rate 1 | UCB0BR1 | 07h |
| eUSCI_B status word | UCB0STATW | 08h |
| eUSCI_B byte counter threshold | UCB0TBCNT | 0Ah |
| eUSCI_B receive buffer | UCB0RXBUF | 0Ch |
| eUSCI_B transmit buffer | UCB0TXBUF | 0Eh |
| eUSCI_B I2C own address 0 | UCB0I2COA0 | 14h |
| eUSCI_B I2C own address 1 | UCB0I2COA1 | 16h |
| eUSCI_B I2C own address 2 | UCB0I2COA2 | 18h |
| eUSCI_B I2C own address 3 | UCB0I2COA3 | 1Ah |
| eUSCI_B receive address | UCB0ADDRX | 1Ch |
| eUSCI_B address mask | UCB0ADDMASK | 1Eh |
| eUSCI_B I2C slave address | UCB0I2CSA | 20h |
| eUSCI_B interrupt enable | UCB0IE | 2Ah |
| eUSCI_B interrupt flags | UCB0IFG | 2Ch |
| eUSCI_B interrupt vector word | UCB0IV | 2Eh |

Table 6-38. Backup Memory Registers (Base Address: 0660h)

| REGISTER DESCRIPTION | REGISTER | OFFSET |
|----------------------|----------|--------|
| Backup memory 0 | BAKMEM0 | 00h |
| Backup memory 1 | BAKMEM1 | 02h |
| Backup memory 2 | BAKMEM2 | 04h |
| Backup memory 3 | BAKMEM3 | 06h |
| Backup memory 4 | BAKMEM4 | 08h |
| Backup memory 5 | BAKMEM5 | 0Ah |
| Backup memory 6 | BAKMEM6 | 0Ch |
| Backup memory 7 | BAKMEM7 | 0Eh |
| Backup memory 8 | BAKMEM8 | 10h |
| Backup memory 9 | BAKMEM9 | 12h |
| Backup memory 10 | BAKMEM10 | 14h |
| Backup memory 11 | BAKMEM11 | 16h |
| Backup memory 12 | BAKMEM12 | 18h |
| Backup memory 13 | BAKMEM13 | 1Ah |
| Backup memory 14 | BAKMEM14 | 1Ch |
| Backup memory 15 | BAKMEM15 | 1Eh |

Table 6-39. ADC Registers (Base Address: 0700h)

| REGISTER DESCRIPTION | REGISTER | OFFSET |
|--------------------------------------|----------|--------|
| ADC control 0 | ADCCTL0 | 00h |
| ADC control 1 | ADCCTL1 | 02h |
| ADC control 2 | ADCCTL2 | 04h |
| ADC window comparator low threshold | ADCLO | 06h |
| ADC window comparator high threshold | ADCHI | 08h |
| ADC memory control 0 | ADCMCTL0 | 0Ah |
| ADC conversion memory | ADCMEM0 | 12h |
| ADC interrupt enable | ADCIE | 1Ah |
| ADC interrupt flags | ADCIFG | 1Ch |
| ADC interrupt vector word | ADCIV | 1Eh |

Table 6-40. eCOMP0 Registers (Base Address: 08E0h)

| REGISTER DESCRIPTION | REGISTER | OFFSET |
|---------------------------------|-----------|--------|
| Comparator control 0 | CPCTL0 | 00h |
| Comparator control 1 | CPCTL1 | 02h |
| Comparator interrupt | CPINT | 06h |
| Comparator interrupt vector | CPIV | 08h |
| Comparator built-in DAC control | CPDACCTL | 10h |
| Comparator built-in DAC data | CPDACDATA | 12h |

Table 6-41. SAC0 Registers (Base Address: 0C80h)

| REGISTER DESCRIPTION | REGISTER | OFFSET |
|----------------------|----------|--------|
| SAC0 OA control | SAC0OA | 00h |

Table 6-42. TIA0 Registers (Base Address: 0F00h)

| REGISTER DESCRIPTION | REGISTER | OFFSET |
|----------------------|----------|--------|
| TIA control | TRICTL | 00h |

6.12 Input/Output Diagrams

6.12.1 Port P1 Input/Output With Schmitt Trigger

Figure 6-5 shows the port diagram. Table 6-43 summarizes the selection of the port functions.

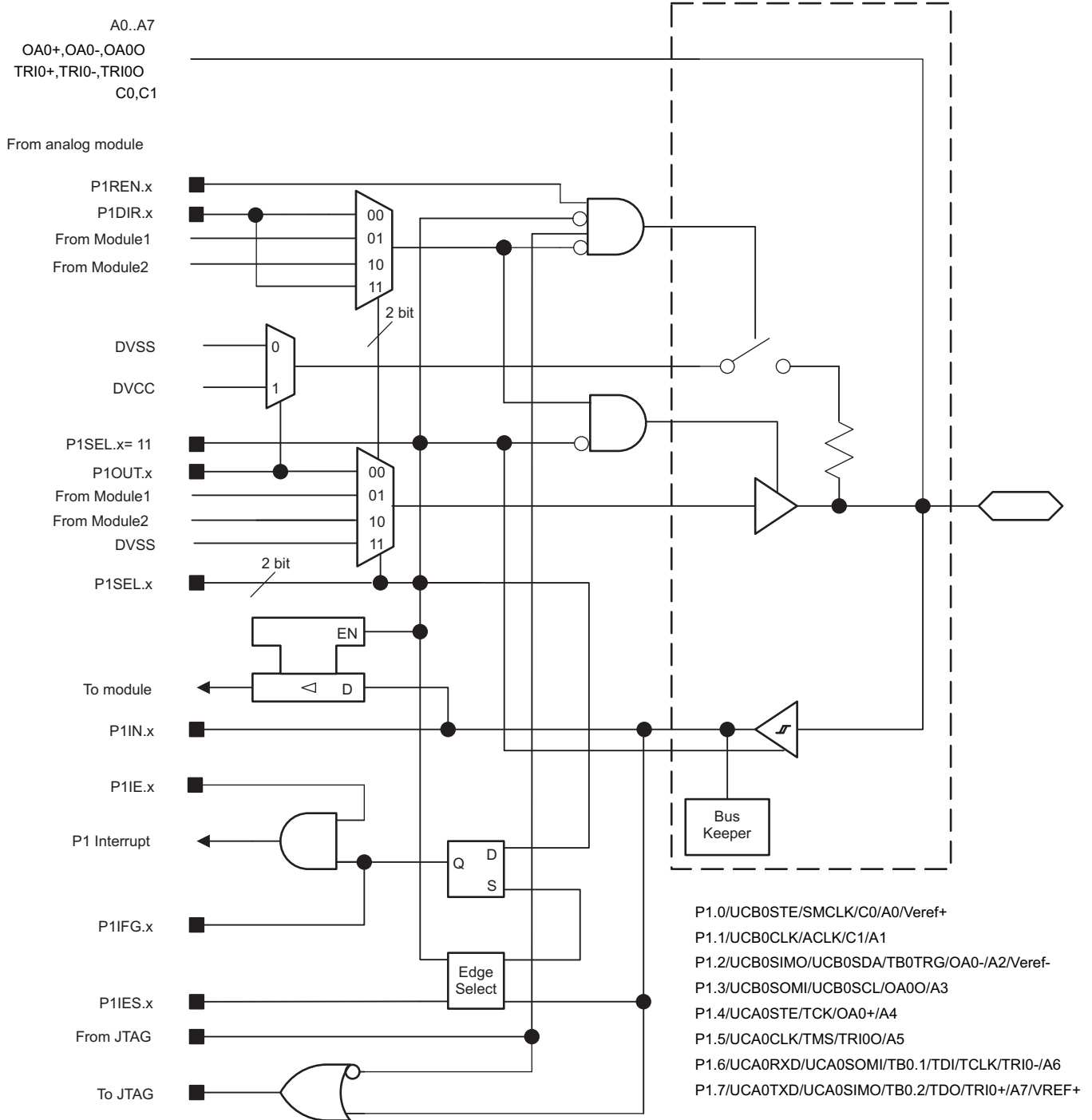

NOTE: Functional representation only.

Figure 6-5. Port P1 Input/Output With Schmitt Trigger

Table 6-43. Port P1 Pin Functions

| PIN NAME (P1.x) | x | FUNCTION | CONTROL BITS AND SIGNALS ⁽¹⁾ | | |
|--|---|------------------|---|--------|----------|
| | | | P1DIR.x | P1SELx | JTAG |
| P1.0/UCB0STE/SMCLK/ C0/A0/Veref+ | 0 | P1.0 (I/O) | I: 0; O: 1 | 00 | N/A |
| | | UCB0STE | X | 01 | N/A |
| | | SMCLK | 1 | 10 | N/A |
| | | VSS | 0 | | |
| | | C0, A0/Veref+ | X | 11 | N/A |
| P1.1/UCB0CLK/ACLK/ C1A1 | 1 | P1.1 (I/O) | I: 0; O: 1 | 0 | N/A |
| | | UCB0CLK | X | 01 | N/A |
| | | ACLK | 1 | 10 | N/A |
| | | VSS | 0 | | |
| | | C1, A1 | X | 11 | N/A |
| P1.2/UCB0SIMO/ UCB0SDA/TB0TRG/ OA0-/A2/Veref- | 2 | P1.2 (I/O) | I: 0; O: 1 | 00 | N/A |
| | | UCB0SIMO/UCB0SDA | X | 01 | N/A |
| | | TB0TRG | 0 | 10 | N/A |
| | | OA0-, A2/Veref- | X | 11 | N/A |
| P1.3/UCB0SOMI/ UCB0SCL/OA00/A3 | 3 | P1.3 (I/O) | I: 0; O: 1 | 00 | N/A |
| | | UCB0SOMI/UCB0SCL | X | 01 | N/A |
| | | OA00, A3 | X | 11 | N/A |
| P1.4/UCA0STE/TCK/ OA0+/A4 | 4 | P1.4 (I/O) | I: 0; O: 1 | 00 | Disabled |
| | | UCA0STE | X | 01 | Disabled |
| | | OA0+, A4 | X | 11 | Disabled |
| | | JTAG TCK | X | X | TCK |
| P1.5/UCA0CLK/TMS/ TRI00/A5 | 5 | P1.5 (I/O) | I: 0; O: 1 | 00 | Disabled |
| | | UCA0CLK | X | 01 | Disabled |
| | | TRI00, A5 | X | 11 | Disabled |
| | | JTAG TMS | X | X | TMS |
| P1.6/UCA0RXD/ UCA0SOMI/TB0.1/TDI/ TCLK/TRI0-/A6 | 6 | P1.6 (I/O) | I: 0; O: 1 | 00 | Disabled |
| | | UCA0RXD/UCA0SOMI | X | 01 | Disabled |
| | | TB0.CCI1A | 0 | 10 | Disabled |
| | | TB0.1 | 1 | | |
| | | TRI0-, A6 | X | 11 | Disabled |
| | | JTAG TDI/TCLK | X | X | TDI/TCLK |
| P1.7/UCA0TXD/ UCA0SIMO/TB0.2/TDO/ TRI0+/A7/VREF+ | 7 | P1.7 (I/O) | I: 0; O: 1 | 00 | Disabled |
| | | UCA0TXD/UCA0SIMO | X | 01 | Disabled |
| | | TB0.CCI2A | 0 | 10 | Disabled |
| | | TB0.2 | 1 | | |
| | | TRI0+, A7, VREF+ | X | 11 | Disabled |
| | | JTAG TDO | X | X | TDO |

(1) X = don't care

6.12.2 Port P2 Input/Output With Schmitt Trigger

Figure 6-6 shows the port diagram. Table 6-44 summarizes the selection of the port functions.

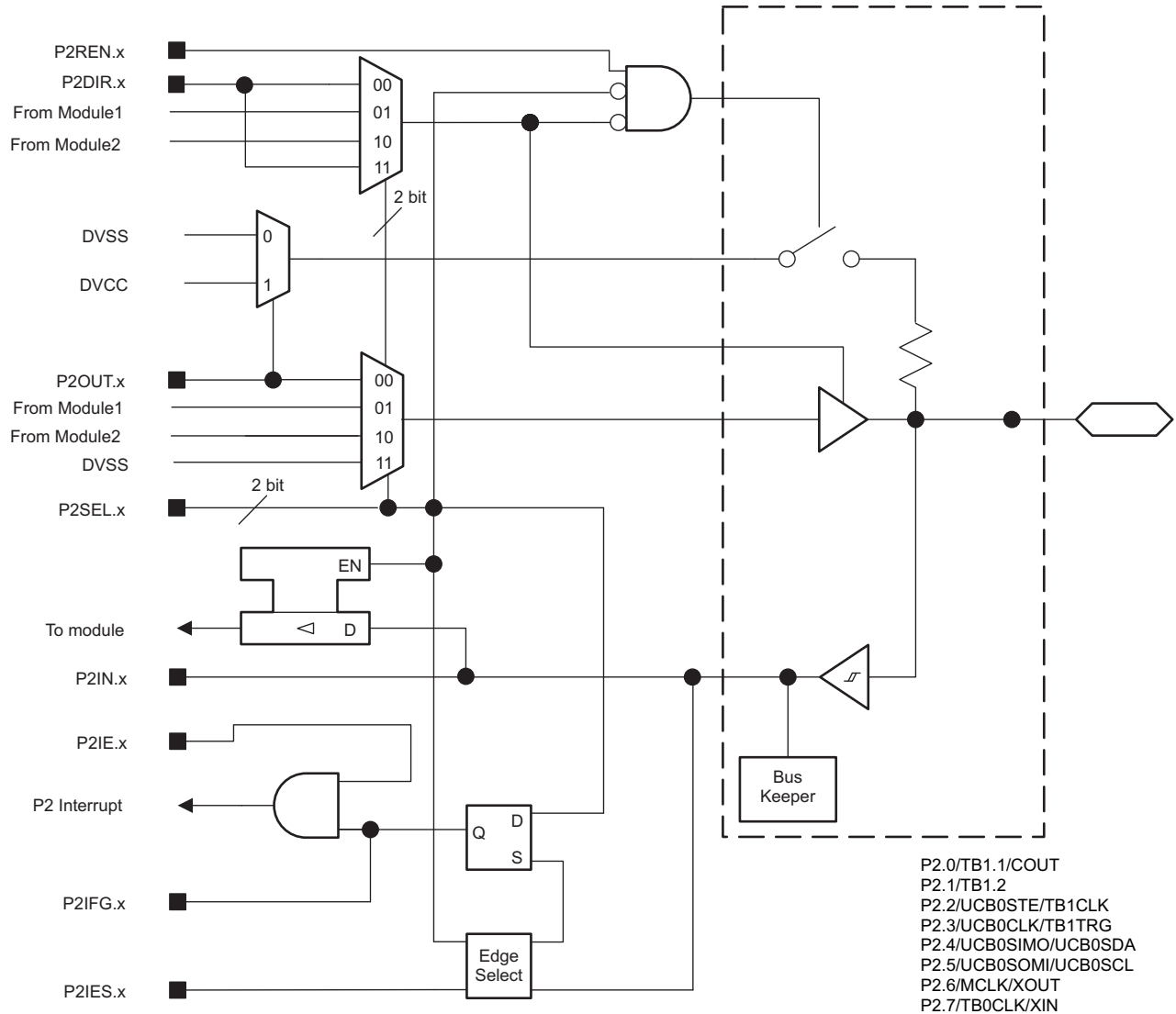

NOTE: Functional representation only.

Figure 6-6. Port P2 Input/Output With Schmitt Trigger

Table 6-44. Port P2 Pin Functions

| PIN NAME (P2.x) | x | FUNCTION | CONTROL BITS AND SIGNALS ⁽¹⁾ | |
|-----------------------------|---|-------------------------|---|--------|
| | | | P2DIR.x | P2SELx |
| P2.0/TB1.1/COU _T | 0 | P2.0 (I/O) | I: 0; O: 1 | 00 |
| | | TB1.CCI1A | 0 | 01 |
| | | TB1.1 | 1 | |
| | | COU _T | 1 | 10 |
| P2.1/TB1.2 | 1 | P2.1 (I/O) ₀ | I: 0; O: 1 | 00 |
| | | TB1.CCI2A | 0 | 01 |
| | | TB1.2 | 1 | |
| P2.2/UCB0STE/TB1CLK | 2 | P2.2 (I/O) | I: 0; O: 1 | 00 |
| | | UCB0STE | X | 01 |
| | | TB1CLK | 0 | 10 |
| | | VSS | 1 | |
| P2.3/UCB0CLK/TB1TRG | 3 | P2.3 (I/O) | I: 0; O: 1 | 00 |
| | | UCB0CLK | X | 01 |
| | | TB1TRG | 0 | 10 |
| P2.4/UCB0SIMO/UCB0SDA | 4 | P2.4 (I/O) | I: 0; O: 1 | 00 |
| | | UCB0SIMO/UCB0SDA | X | 01 |
| P2.5/UCB0SOMI/UCB0SCL | 5 | P2.5 (I/O) | I: 0; O: 1 | 00 |
| | | UCB0SOMI/UCB0SCL | X | 01 |
| P2.6/MCLK/XOU _T | 6 | P2.6 (I/O) | I: 0; O: 1 | 00 |
| | | MCLK | 1 | 01 |
| | | VSS | 0 | |
| | | XOU _T | X | 10 |
| P2.7/TB0CLK/XIN | 7 | P2.7 (I/O) | I: 0; O: 1 | 00 |
| | | TB0CLK | 0 | 01 |
| | | VSS | 1 | |
| | | XIN | X | 10 |

(1) X = don't care

6.13 Device Descriptors (TLV)

Table 6-45 lists the Device IDs of the MSP430FR231x MCU variants. Table 6-46 lists the contents of the device descriptor tag-length-value (TLV) structure for the devices.

Table 6-45. Device IDs

| DEVICE | DEVICE ID | |
|--------------|-----------|-------|
| | 1A04h | 1A05h |
| MSP430FR2311 | F0 | 82 |
| MSP430FR2310 | F1 | 82 |

Table 6-46. Device Descriptors

| DESCRIPTION | | MSP430FR231x | |
|--|--|--------------|-----------------|
| | | ADDRESS | VALUE |
| Info block | Info length | 1A00h | 06h |
| | CRC length | 1A01h | 06h |
| | CRC value ⁽¹⁾ | 1A02h | Per unit |
| | | 1A03h | Per unit |
| | Device ID | 1A04h | See Table 6-45. |
| | | 1A05h | |
| | Hardware revision | 1A06h | Per unit |
| Firmware revision | 1A07h | Per unit | |
| Die record | Die record tag | 1A08h | 08h |
| | Die record length | 1A09h | 0Ah |
| | Lot wafer ID | 1A0Ah | Per unit |
| | | 1A0Bh | Per unit |
| | | 1A0Ch | Per unit |
| | | 1A0Dh | Per unit |
| | Die X position | 1A0Eh | Per unit |
| | | 1A0Fh | Per unit |
| | Die Y position | 1A10h | Per unit |
| | | 1A11h | Per unit |
| Test result | 1A12h | Per unit | |
| | 1A13h | Per unit | |
| ADC calibration | ADC calibration tag | 1A14h | Per unit |
| | ADC calibration length | 1A15h | Per unit |
| | ADC gain factor | 1A16h | Per unit |
| | | 1A17h | Per unit |
| | ADC offset | 1A18h | Per unit |
| | | 1A19h | Per unit |
| | ADC 1.5-V reference, temperature 30°C ⁽²⁾ | 1A1Ah | Per unit |
| | | 1A1Bh | Per unit |
| ADC 1.5-V reference, temperature 85°C ⁽²⁾ | 1A1Ch | Per unit | |
| | 1A1Dh | Per unit | |

(1) The CRC value covers the checksum from 0x1A04h to 0x1A77h by applying CRC-CCITT-16 polynomial of $X^{16} + X^{12} + X^5 + 1$

(2) TI recommends to do a two-point calibration for the on-chip temperature sensor in precision application.

Table 6-46. Device Descriptors (continued)

| DESCRIPTION | | MSP430FR231x | |
|-------------------------------|--|--------------|----------|
| | | ADDRESS | VALUE |
| Reference and DCO calibration | Calibration tag | 1A1Eh | 12h |
| | Calibration length | 1A1Fh | 04h |
| | 1.5-V reference factor | 1A20h | Per unit |
| | | 1A21h | Per unit |
| | DCO tap settings for 16 MHz, temperature 30°C ⁽³⁾ | 1A22h | Per unit |
| | | 1A23h | Per unit |

(3) This value can be directly loaded into the DCO bits in the CSCTL0 register to get an accurate 16-MHz frequency at room temperature, especially when MCU exits from LPM3 and below. TI also suggests using a predivider to decrease the frequency if the temperature drift might result an overshoot above 16 MHz.

6.14 Identification

6.14.1 Revision Identification

The device revision information is shown as part of the top-side marking on the device package. The device-specific errata sheet describes these markings. For links to all of the errata sheets for the devices in this data sheet, see [§ 8.4](#).

The hardware revision is also stored in the Device Descriptor structure in the Info Block section. For details on this value, see the "Hardware Revision" entries in [Section 6.13](#).

6.14.2 Device Identification

The device type can be identified from the top-side marking on the device package. The device-specific errata sheet describes these markings. For links to all of the errata sheets for the devices in this data sheet, see [§ 8.4](#).

A device identification value is also stored in the Device Descriptor structure in the Info Block section. For details on this value, see the "Device ID" entries in [Section 6.13](#).

6.14.3 JTAG Identification

Programming through the JTAG interface, including reading and identifying the JTAG ID, is described in detail in the [MSP430 Programming With the JTAG Interface](#).

7 Applications, Implementation, and Layout

NOTE

Information in the following applications sections is not part of the TI component specification, and TI does not warrant its accuracy or completeness. TI's customers are responsible for determining suitability of components for their purposes. Customers should validate and test their implementation to confirm system functionality.

7.1 Device Connection and Layout Fundamentals

This section describes the recommended guidelines when designing with the MSP430. These guidelines are to make sure that the device has proper connections for powering, programming, debugging, and optimum analog performance.

7.1.1 Power Supply Decoupling and Bulk Capacitors

TI recommends connecting a combination of a 10- μ F capacitor and a 100-nF low-ESR ceramic decoupling capacitor to the DVCC pin. Higher-value capacitors may be used but can affect supply rail ramp-up time. Decoupling capacitors must be placed as close as possible to the pins that they decouple (within a few millimeters).

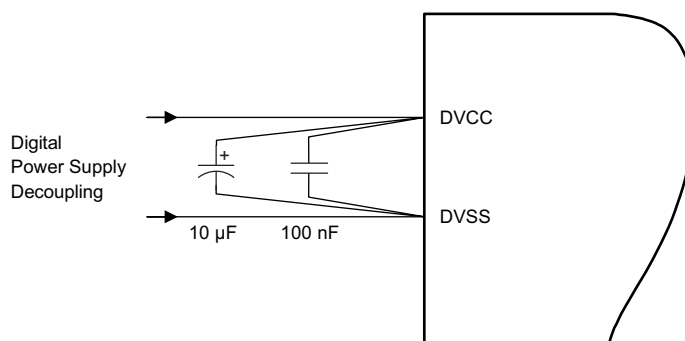

Figure 7-1. Power Supply Decoupling

7.1.2 External Oscillator

Depending on the device variant (see [Table 3-1](#)), the device can support a low-frequency crystal (32 kHz) on the LFXT pins, a high-frequency crystal on the HFXT pins, or both. External bypass capacitors for the crystal oscillator pins are required.

It is also possible to apply digital clock signals to the LFXIN and HFXIN input pins that meet the specifications of the respective oscillator if the appropriate LFXTBYPASS or HFXTBYPASS mode is selected. In this case, the associated LFXOUT and HFXOUT pins can be used for other purposes. If the LFXOUT and HFXOUT pins are left unused, they must be terminated according to [Section 4.6](#).

[Figure 7-2](#) shows a typical connection diagram.

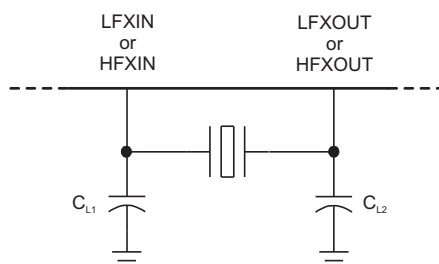

Figure 7-2. Typical Crystal Connection

See [MSP430 32-kHz Crystal Oscillators](#) for more information on selecting, testing, and designing a crystal oscillator with the MSP430 devices.

7.1.3 JTAG

With the proper connections, the debugger and a hardware JTAG interface (such as the MSP-FET or MSP-FET430UIF) can be used to program and debug code on the target board. In addition, the connections also support the MSP-GANG production programmers, thus providing an easy way to program prototype boards, if desired. [Figure 7-3](#) shows the connections between the 14-pin JTAG connector and the target device required to support in-system programming and debugging for 4-wire JTAG communication. [Figure 7-4](#) shows the connections for 2-wire JTAG mode (Spy-Bi-Wire).

The connections for the MSP-FET and MSP-FET430UIF interface modules and the MSP-GANG are identical. Both can supply V_{CC} to the target board (through pin 2). In addition, the MSP-FET and MSP-FET430UIF interface modules and MSP-GANG have a V_{CC} sense feature that, if used, requires an alternate connection (pin 4 instead of pin 2). The V_{CC} -sense feature detects the local V_{CC} present on the target board (that is, a battery or other local power supply) and adjusts the output signals accordingly. [Figure 7-3](#) and [Figure 7-4](#) show a jumper block that supports both scenarios of supplying V_{CC} to the target board. If this flexibility is not required, the desired V_{CC} connections may be hardwired to eliminate the jumper block. Pins 2 and 4 must not be connected at the same time.

For additional design information regarding the JTAG interface, see the [MSP430 Hardware Tools User's Guide](#).

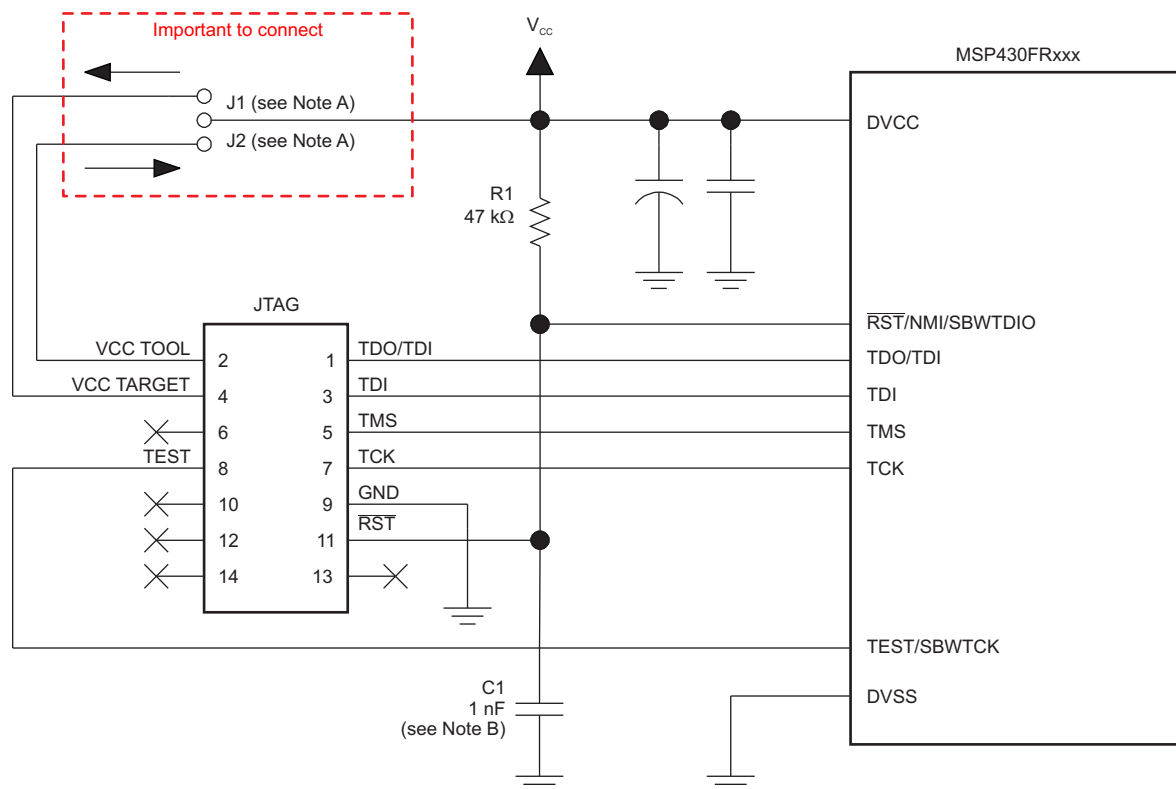

Copyright © 2016, Texas Instruments Incorporated

- If a local target power supply is used, make connection J1. If power from the debug or programming adapter is used, make connection J2.
- The upper limit for C1 is 1.1 nF when using TI tools. TI recommends a 1-nF capacitor to enable high-speed SBW communication.

Figure 7-3. Signal Connections for 4-Wire JTAG Communication

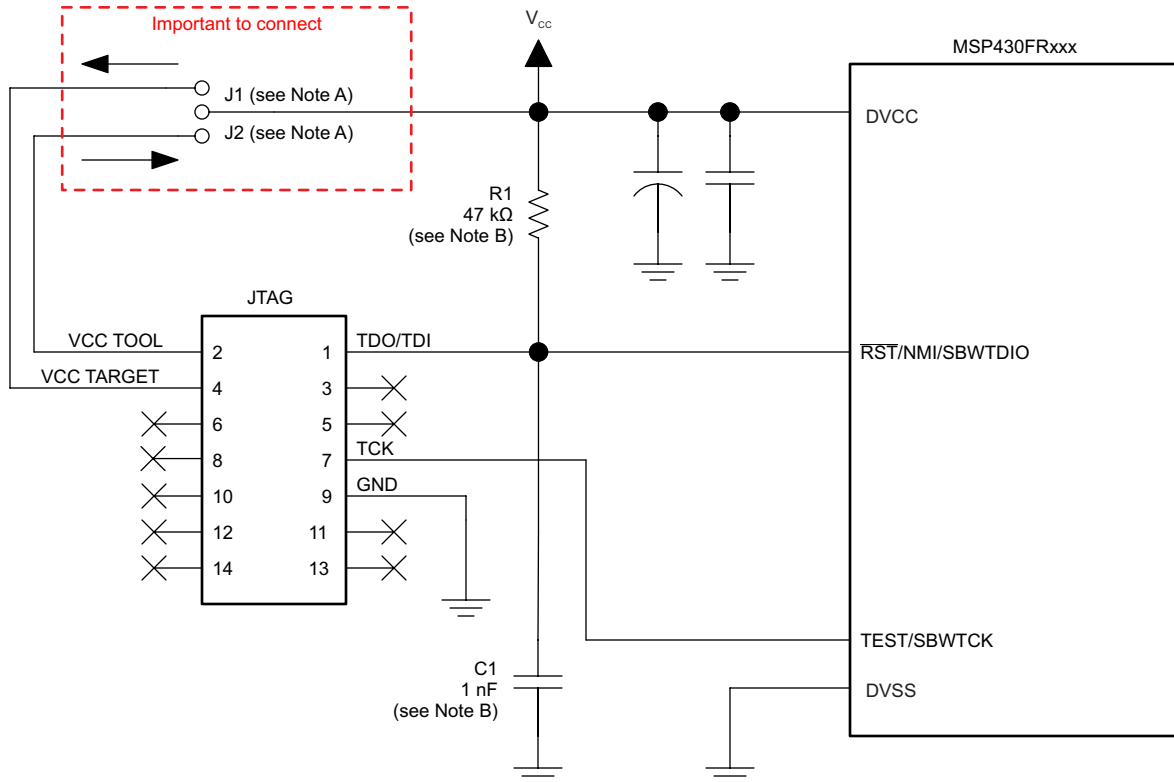

Copyright © 2016, Texas Instruments Incorporated

- Make connection J1 if a local target power supply is used, or make connection J2 if the target is powered from the debug or programming adapter.
- The device $\overline{\text{RST/NMI/SBWDIO}}$ pin is used in 2-wire mode for bidirectional communication with the device during JTAG access, and any capacitance that is attached to this signal may affect the ability to establish a connection with the device. The upper limit for C1 is 1.1 nF when using TI tools. TI recommends a 1-nF capacitor to enable high-speed SBW communication.

Figure 7-4. Signal Connections for 2-Wire JTAG Communication (Spy-Bi-Wire)

7.1.4 Reset

The reset pin can be configured as a reset function (default) or as an NMI function in the Special Function Register (SFR), SFRRPCR.

In reset mode, the $\overline{\text{RST/NMI}}$ pin is active low, and a pulse applied to this pin that meets the reset timing specifications generates a BOR-type device reset.

Setting SYSNMI causes the $\overline{\text{RST/NMI}}$ pin to be configured as an external NMI source. The external NMI is edge sensitive, and its edge is selectable by SYSNMIIES. Setting the NMIIE enables the interrupt of the external NMI. When an external NMI event occurs, the NMIIFG is set.

The $\overline{\text{RST/NMI}}$ pin can have either a pullup or pulldown that is enabled or not. SYSRSTUP selects either pullup or pulldown, and SYSRSTRE causes the pullup (default) or pulldown to be enabled (default) or not. If the $\overline{\text{RST/NMI}}$ pin is unused, it is required either to select and enable the internal pullup or to connect an external 47-k Ω pullup resistor to the $\overline{\text{RST/NMI}}$ pin with a 10-nF pulldown capacitor. The pulldown capacitor should not exceed 1.1 nF when using devices with Spy-Bi-Wire interface in Spy-Bi-Wire mode or in 4-wire JTAG mode with TI tools like FET interfaces or GANG programmers.

See the [MSP430FR4xx and MSP430FR2xx Family User's Guide](#) for more information on the referenced control registers and bits.

7.1.5 Unused Pins

For details on the connection of unused pins, see [Section 4.6](#).

7.1.6 General Layout Recommendations

- Proper grounding and short traces for external crystal to reduce parasitic capacitance. See [MSP430 32-kHz Crystal Oscillators](#) for recommended layout guidelines.
- Proper bypass capacitors on DVCC, AVCC, and reference pins if used.
- Avoid routing any high-frequency signal close to an analog signal line. For example, keep digital switching signals such as PWM or JTAG signals away from the oscillator circuit and ADC signals.
- Proper ESD level protection should be considered to protect the device from unintended high-voltage electrostatic discharge. See [MSP430 System-Level ESD Considerations](#) for guidelines.

7.1.7 Do's and Don'ts

During power up, power down, and device operation, the voltage difference between AVCC and DVCC must not exceed the limits specified in the [Absolute Maximum Ratings](#) section. Exceeding the specified limits may cause malfunction of the device including erroneous writes to RAM and FRAM.

7.2 Peripheral- and Interface-Specific Design Information

7.2.1 ADC Peripheral

7.2.1.1 Partial Schematic

Figure 7-5 shows the recommended decoupling circuit when an external voltage reference is used.

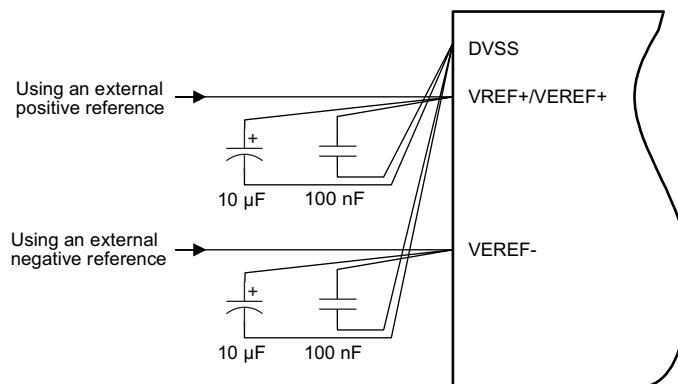

Figure 7-5. ADC Grounding and Noise Considerations

7.2.1.2 Design Requirements

As with any high-resolution ADC, appropriate printed-circuit-board layout and grounding techniques should be followed to eliminate ground loops, unwanted parasitic effects, and noise.

Ground loops are formed when return current from the ADC flows through paths that are common with other analog or digital circuitry. If care is not taken, this current can generate small unwanted offset voltages that can add to or subtract from the reference or input voltages of the ADC. The general guidelines in [Section 7.1.1](#) combined with the connections shown in [Figure 7-5](#) prevent this.

In addition to grounding, ripple and noise spikes on the power-supply lines that are caused by digital switching or switching power supplies can corrupt the conversion result. TI recommends a noise-free design using separate analog and digital ground planes with a single-point connection to achieve high accuracy.

[Figure 7-5](#) shows the recommended decoupling circuit when an external voltage reference is used. The internal reference module has a maximum drive current as described in the sections *ADC Pin Enable* and *1.2-V Reference Settings* of the [MSP430FR4xx and MSP430FR2xx Family User's Guide](#).

The reference voltage must be a stable voltage for accurate measurements. The capacitor values that are selected in the general guidelines filter out the high- and low-frequency ripple before the reference voltage enters the device. In this case, the 10- μ F capacitor buffers the reference pin and filters any low-frequency ripple. A bypass capacitor of 100 nF filters out any high-frequency noise.

7.2.1.3 Layout Guidelines

Components that are shown in the partial schematic (see [Figure 7-5](#)) should be placed as close as possible to the respective device pins to avoid long traces, because they add additional parasitic capacitance, inductance, and resistance on the signal.

Avoid routing analog input signals close to a high-frequency pin (for example, a high-frequency PWM), because the high-frequency switching can be coupled into the analog signal.

7.3 Typical Applications

[Table 7-1](#) provides a link to a LaunchPad™ development kit. For the most up-to-date list of available tools and TI Designs, see the device-specific product folders listed in [节 8.5](#).

Table 7-1. Tools

| NAME | LINK |
|--|---|
| MSP430FR2311 LaunchPad Development Kit | http://www.ti.com/tool/MSP-EXP430FR2311 |

8 器件和文档支持

8.1 使用入门

有关可帮助进行开发的 MSP430™ 系列器件、工具和库的更多信息，请查看 [MSP430™ 超低功耗感应和测量 MCU 概述](#)。

8.2 器件命名规则

为了标示产品开发周期所处的阶段，TI 为所有 MSP MCU 器件的部件号分配了前缀。每个 MSP MCU 商用系列产品成员都具有以下两个前缀之一：MSP 或 XMS。这些前缀代表了产品开发的发展阶段，即从工程原型 (XMS) 直到完全合格的生产器件 (MSP)。

XMS - 实验器件，不一定代表最终器件的电气规格

MSP - 完全合格的生产器件

XMS 器件在供货时附带如下免责声明：

“开发中的产品用于内部评估用途。”

MSP 器件的特性已经全部明确，并且器件的质量和可靠性已经完全论证。TI 的标准保修证书对该器件适用。

预测显示原型器件 (XMS) 的故障率大于标准生产器件。由于这些器件的预计最终使用故障率尚不确定，德州仪器 (TI) 建议不要将它们用于任何生产系统。请仅使用合格的生产器件。

TI 器件的命名规则还包括一个带有器件系列名称的后缀。此后缀表示温度范围、封装类型和配送形式。图 8-1 提供了解读完整器件名称的图例。

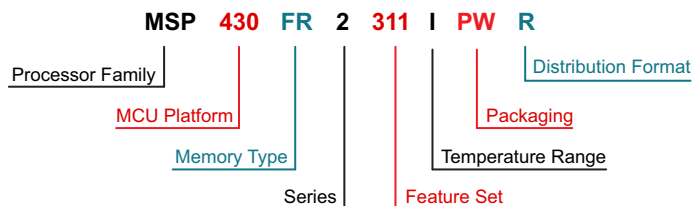

| | | |
|----------------------------|--|---|
| Processor Family | MSP = Mixed-Signal Processor XMS = Experimental Silicon | |
| MCU Platform | MSP430 = TI's MSP430 16-Bit Low-Power Microcontroller Platform | |
| Memory Type | FR = FRAM | |
| Series | 2 = FRAM 2 Series up to 16 MHz without LCD | |
| Feature Set | First and Second Digits: Smart Analog Combo (SAC) Level / ADC Channels / COMP / 16-bit Timers / I/O 31 = SAC-L1 / Up to 8 / 1 / 2 / Up to 16 | Third Digit: FRAM (KB) / SRAM (KB) 1 = 4 / 1 0 = 2 / 1 |
| Temperature Range | I = -40°C to 85°C | |
| Packaging | www.ti.com/packaging | |
| Distribution Format | T = Small reel R = Large reel No marking = Tube or tray | |

图 8-1. 器件命名规则

8.3 工具和软件

表 8-1 列出了这些微控制器支持的调试功能。请参阅《适用于 MSP430 MCU 的 Code Composer Studio IDE 用户指南》，以了解有关可用功能的详细信息。

表 8-1. 硬件特性

| MSP430 架构 | 四线制 JTAG | 两线制 JTAG | 断点 (N) | 范围断点 | 时钟控制 | 状态序列发生器 | 跟踪缓冲器 | LPMx.5 调试支持 | EEM 版本 |
|-----------|----------|----------|--------|------|------|---------|-------|-------------|--------|
| MSP430Xv2 | 有 | 有 | 3 | 有 | 是 | 否 | 否 | 否 | S |

设计套件与评估模块

MSP430FR2311 LaunchPad 开发套件

MSP-EXP430FR2311 LaunchPad 开发套件是适用于 MSP430FR2311 MCU 的易用型微控制器开发板。它包含了在 MSP430FR2x FRAM 平台上快速开始开发所需要的全部资源，包括用于编程、调试和能量测量的板载仿真。

MSP-FET + MSP-TS430PW20 FRAM 微控制器开发套件包

MSP-FET430U20 开发套件包将两种调试工具相结合，支持 MSP430FR23x 微控制器的 20 引脚 PW 封装（例如 MSP430FR2311PW20）。两种工具分别为 MSP-TS430PW20 和 MSP-FET。

MSP-TS430PW20 - 适用于 MSP430FR2x MCU 的 20 引脚目标开发板

MSP-TS430PW20 是一款独立的 ZIF 插座目标板，用于通过 JTAG 接口或 Spy-Bi-Wire（两线制 JTAG）协议对 MSP430 MCU 进行系统内编程和调试。该开发板支持所有采用 20 引脚或 16 引脚 TSSOP 封装（TI 封装代码：PW）的 MSP430FR23x 和 MSP430FR21x 闪存器件。

软件

MSP430Ware™ 软件

MSP430Ware 软件集合了所有 MSP430 器件的代码示例、数据表以及其他设计资源，打包提供给用户。除了提供已有 MSP430 设计资源的完整集合外，MSP430Ware 软件还包含名为 MSP430 驱动程序库的高级 API。借助该库可以轻松地对 MSP430 硬件进行编程。MSP430Ware 软件以 CCS 组件或独立软件包两种形式提供。

MSP430FR231x 代码示例

根据不同应用需求配置各集成外设的每个 MSP 器件均具备相应的 C 代码示例。

MSP 驱动程序库

MSP 驱动程序库的抽象 API 提供易用的函数调用，无需直接操纵 MSP430 硬件的位与字节。完整的文档通过具有帮助意义的 API 指南交付，其中包括有关每个函数调用和经过验证的参数的详细信息。开发人员可以使用驱动程序库功能，以最低开销编写完整项目。

MSP EnergyTrace™ 技术

适用于 MSP430 微控制器的 EnergyTrace 技术是基于电能的代码分析工具，适用于测量和显示应用的电能系统配置并帮助优化应用以实现超低功耗。

ULP (超低功耗) Advisor

ULP Advisor™ 软件是一款辅助工具，旨在指导开发人员编写更为高效的代码，从而充分利用 MSP430 和 MSP432 微控制器 独特 功能。ULP Advisor 的目标人群是微控制器的资深开发者和开发新手，可以根据详尽的 ULP 检验表检查代码，以便最大限度地减少应用程序的能耗。在编译时，ULP Advisor 会提供通知和备注以突出显示代码中可以进一步优化的区域，进而实现更低功耗。

适用于 MSP 超低功耗微控制器的 FRAM 嵌入式软件实用程序

FRAM 实用程序旨在作为不断扩充的嵌入式软件实用程序集合，其中的实用程序充分利用 FRAM 的超低功耗和近乎无限的写入寿命。这些实用程序适用于 MSP430FRxx FRAM 微控制器并提供示例代码协助应用程序开发。其中的实用程序包含功耗计算实用程序 (CTPL)。CTPL 是一套实用程序 API 集，通过 CTPL 能够轻松使用 LPMx.5 低功耗模式以及强大的关断模式，允许应用程序在检测到功率损耗时节约能耗并恢复关键的系统元件。

IEC60730 软件包

IEC60730 MSP430 软件包经过专门开发，用于协助客户达到 IEC 60730-1:2010 (家用及类似用途的自动化电气控制 - 第 1 部分: 一般要求) B 类产品的要求。其中涵盖家用电器、电弧检测器、电源转换器、电动工具、电动自行车及其他诸多产品。IEC60730 MSP430 软件包可以嵌入在 MSP430 MCU 中 运行的客户应用，从而帮助客户简化其消费类器件在功能安全方面遵循 IEC 60730-1:2010 B 类规范的认证工作。

适用于 MSP 的定点数学库

MSP IQmath 和 Qmath 库是为 C 语言开发者提供的一套经过高度优化的高精度数学运算函数集合，能够将浮点算法无缝嵌入 MSP430 和 MSP432 器件的定点代码中。这些例程通常用于计算密集型实时 应用，而优化的执行速度、高精度以及超低能耗通常是影响这些实时应用的关键因素。与使用浮点数学算法编写的同等代码相比，使用 IQmath 和 Qmath 库可以大幅提高执行速度并显著降低能耗。

适用于 MSP430 的浮点数学库

TI 在低功耗和低成本微控制器领域锐意创新，为您提供 MSPMATHLIB。此标量函数的浮点数学库，能够充分利用器件的智能外设，使速度最高达到标准 MSP430 数学函数的 26 倍。Mathlib 能够轻松集成到您的设计中。该运算库免费使用并集成在 Code Composer Studio IDE 和 IAR Embedded Workbench IDE 中。

开发工具

适用于 MSP 微控制器的 Code Composer Studio™ 集成开发环境

Code Composer Studio (CCS) 集成开发环境 (IDE) 支持所有 MSP 微控制器器件。CCS 包含一整套用于开发和调试嵌入式 应用的工具。它包含了优化的 C/C++ 编译器、源代码编辑器、项目构建环境、调试器、描述器以及其他多种 功能。

命令行编程器

MSP Flasher 是一款基于 shell 的开源接口，可使用 JTAG 或 Spy-Bi-Wire (SBW) 通信通过 FET 编程器或 eZ430 对 MSP 微控制器进行编程。MSP Flasher 可用于将二进制文件 (.txt 或 .hex 文件) 直接下载到 MSP 微控制器，而无需使用 IDE。

MSP MCU 编程器和调试器

MSP-FET 是一款强大的仿真开发工具 (通常称为调试探针)，可帮助用户在 MSP 低功耗微控制器 (MCU) 中快速开发应用。创建 MCU 软件通常需要将生成的二进制程序下载到 MSP 器件中，从而进行验证和调试。

MSP-GANG 生产编程器

MSP Gang 编程器是一款 MSP430 或 MSP432 器件编程器，可同时对多达八个完全相同的 MSP430 或 MSP432 闪存或 FRAM 器件进行编程。MSP Gang 编程器可使用标准的 RS-232 或 USB 连接与主机 PC 相连并提供灵活的编程选项，允许用户完全自定义流程。

8.4 文档支持

以下文档介绍了 MSP430FR231x 微控制器。www.ti.com.cn 网站上提供了这些文档的副本。

接收文档更新通知

要接收文档更新通知（包括芯片勘误表），请转至 ti.com.cn 上您的器件对应的产品文件夹（请参见节 8.5 获取产品文件夹链接）。请单击右上角的“通知我”按钮。点击注册后，即可收到产品信息更改每周摘要（如有）。有关更改的详细信息，请查阅已修订文档的修订历史记录。

勘误

《MSP430FR2311 器件勘误表》

说明了功能规格的已知例外情况。

《MSP430FR2310 器件勘误表》

说明了功能规格的已知例外情况。

用户指南

《MSP430FR4xx 和 MSP430FR2xx 系列用户指南》

可说明。

《MSP430 FRAM 器件引导加载程序 (BSL) 用户指南》

MSP430 MCU 上的引导加载程序 (BSL) 允许用户在原型设计、投产和维护等各阶段与 MSP430 MCU 中的嵌入式存储器进行通信。可编程存储器 (FRAM 存储器) 和数据存储器 (RAM) 均可按要求予以修改。

《通过 JTAG 接口对 MSP430 进行编程》

此文档介绍了使用 JTAG 通信端口擦除、编程和验证基于 MSP430 闪存和 FRAM 的微控制器系列的存储器模块所需的功能。此外，该文档还介绍了如何编程所有 MSP430 器件上均具备的 JTAG 访问安全保险丝。此文档介绍了使用标准四线制 JTAG 接口和两线制 JTAG 接口（也称为 Spy-Bi-Wire (SBW)）的器件访问。

《MSP430 硬件工具用户指南》

此手册介绍了 TI MSP-FET430 闪存仿真工具 (FET) 的硬件。FET 是针对 MSP430 超低功耗微控制器的程序开发工具。文中对提供的接口类型，即并行端口接口和 USB 接口进行了说明。

应用报告

《MSP430 32kHz 晶体振荡器》

选择合适的晶体、正确的负载电路和适当的电路板布局是实现稳定的晶体振荡器的关键。该应用报告总结了晶体振荡器的功能，并介绍了用于选择合适晶体以实现 MSP430 MCU 超低功耗运行的参数。此外，还给出了正确电路板布局的提示和示例。此外，为了确保振荡器在大规模生产后能够稳定运行，还可能需要进行一些振荡器测试，该文档中提供了有关这些测试的详细信息。

《MSP430 系统级 ESD 注意事项》

随着芯片技术向更低电压方向发展以及设计具有成本效益的超低功耗组件的需求的出现，系统级 ESD 要求变得越来越苛刻。该应用报告介绍了不同的 ESD 主题，旨在帮助电路板设计人员和 OEM 理解并设计出稳健耐用的系统级设计。另外还介绍了若干实际应用系统级 ESD 保护设计示例及其结果。

8.5 相关链接

表 8-2 列出了快速访问链接。类别包括技术文档、支持与社区资源、工具与软件，以及申请样片或购买产品的快速链接。

表 8-2. 相关链接

| 器件 | 产品文件夹 | 立即订购 | 技术文档 | 工具与软件 | 支持和社区 |
|--------------|-----------------------|-----------------------|-----------------------|-----------------------|-----------------------|
| MSP430FR2311 | 请单击此处 | 请单击此处 | 请单击此处 | 请单击此处 | 请单击此处 |
| MSP430FR2310 | 请单击此处 | 请单击此处 | 请单击此处 | 请单击此处 | 请单击此处 |

8.6 社区资源

下列链接提供到 TI 社区资源的连接。链接的内容由各个分销商“按照原样”提供。这些内容并不构成 TI 技术规范，并且不一定反映 TI 的观点；请参见 TI 的《使用条款》。

TI E2E™ 社区

TI 的工程师交流 (E2E) 社区。此社区的创建目的是为了促进工程师之间协作。在 e2e.ti.com 中，您可以提问、共享知识、拓展思路，在同领域工程师的帮助下解决问题。

TI 嵌入式处理器维基网页

德州仪器 (TI) 嵌入式处理器维基网页。此网站的建立是为了帮助开发人员熟悉德州仪器 (TI) 的嵌入式处理器，并且也为了促进与这些器件相关的硬件和软件的总体知识的创新和增长。

8.7 商标

LaunchPad, MSP430, MSP430Ware, Code Composer Studio, E2E, EnergyTrace, ULP Advisor, 适用于 MSP 微控制器的 Code Composer Studio are trademarks of Texas Instruments.
All other trademarks are the property of their respective owners.

8.8 静电放电警告



ESD 可能会损坏该集成电路。德州仪器 (TI) 建议通过适当的预防措施处理所有集成电路。如果不遵守正确的处理措施和安装程序，可能会损坏集成电路。

ESD 的损坏小至导致微小的性能降级，大至整个器件故障。精密的集成电路可能更容易受到损坏，这是因为非常细微的参数更改都可能会导致器件与其发布的规格不相符。

8.9 Glossary

TI Glossary This glossary lists and explains terms, acronyms, and definitions.

9 机械、封装和可订购信息

以下页面包含机械、封装和可订购信息。这些信息是指定器件的最新可用数据。这些数据会在无通知且不对本文档进行修订的情况下发生改变。欲获得该数据表的浏览器版本，请查阅左侧的导航栏。

PACKAGING INFORMATION

| Orderable Device | Status (1) | Package Type | Package Drawing | Pins | Package Qty | Eco Plan (2) | Lead finish/ Ball material (6) | MSL Peak Temp (3) | Op Temp (°C) | Device Marking (4/5) | Samples |
|--------------------|---------------|--------------|-----------------|------|-------------|-----------------|--------------------------------------|----------------------|--------------|-------------------------|-------------------------|
| MSP430FR2310IPW16 | ACTIVE | TSSOP | PW | 16 | 90 | RoHS & Green | NIPDAU | Level-2-260C-1 YEAR | -40 to 85 | FR2310 | Samples |
| MSP430FR2310IPW16R | ACTIVE | TSSOP | PW | 16 | 2000 | RoHS & Green | NIPDAU | Level-2-260C-1 YEAR | -40 to 85 | FR2310 | Samples |
| MSP430FR2310IPW20 | ACTIVE | TSSOP | PW | 20 | 70 | RoHS & Green | NIPDAU | Level-2-260C-1 YEAR | -40 to 85 | FR2310 | Samples |
| MSP430FR2310IPW20R | ACTIVE | TSSOP | PW | 20 | 2000 | RoHS & Green | NIPDAU | Level-2-260C-1 YEAR | -40 to 85 | FR2310 | Samples |
| MSP430FR2310IRGYR | ACTIVE | VQFN | RGY | 16 | 3000 | RoHS & Green | NIPDAU | Level-2-260C-1 YEAR | -40 to 85 | FR2310 | Samples |
| MSP430FR2310IRGYT | ACTIVE | VQFN | RGY | 16 | 250 | RoHS & Green | NIPDAU | Level-2-260C-1 YEAR | -40 to 85 | FR2310 | Samples |
| MSP430FR2311IPW16 | ACTIVE | TSSOP | PW | 16 | 90 | RoHS & Green | NIPDAU | Level-2-260C-1 YEAR | -40 to 85 | FR2311 | Samples |
| MSP430FR2311IPW16R | ACTIVE | TSSOP | PW | 16 | 2000 | RoHS & Green | NIPDAU | Level-2-260C-1 YEAR | -40 to 85 | FR2311 | Samples |
| MSP430FR2311IPW20 | ACTIVE | TSSOP | PW | 20 | 70 | RoHS & Green | NIPDAU | Level-2-260C-1 YEAR | -40 to 85 | FR2311 | Samples |
| MSP430FR2311IPW20R | ACTIVE | TSSOP | PW | 20 | 2000 | RoHS & Green | NIPDAU | Level-2-260C-1 YEAR | -40 to 85 | FR2311 | Samples |
| MSP430FR2311IRGYR | ACTIVE | VQFN | RGY | 16 | 3000 | RoHS & Green | NIPDAU | Level-2-260C-1 YEAR | -40 to 85 | FR2311 | Samples |
| MSP430FR2311IRGYT | ACTIVE | VQFN | RGY | 16 | 250 | RoHS & Green | NIPDAU | Level-2-260C-1 YEAR | -40 to 85 | FR2311 | Samples |

(1) The marketing status values are defined as follows:

ACTIVE: Product device recommended for new designs.

LIFEBUY: TI has announced that the device will be discontinued, and a lifetime-buy period is in effect.

NRND: Not recommended for new designs. Device is in production to support existing customers, but TI does not recommend using this part in a new design.

PREVIEW: Device has been announced but is not in production. Samples may or may not be available.

OBSOLETE: TI has discontinued the production of the device.

(2) **RoHS:** TI defines "RoHS" to mean semiconductor products that are compliant with the current EU RoHS requirements for all 10 RoHS substances, including the requirement that RoHS substance do not exceed 0.1% by weight in homogeneous materials. Where designed to be soldered at high temperatures, "RoHS" products are suitable for use in specified lead-free processes. TI may reference these types of products as "Pb-Free".

RoHS Exempt: TI defines "RoHS Exempt" to mean products that contain lead but are compliant with EU RoHS pursuant to a specific EU RoHS exemption.

Green: TI defines "Green" to mean the content of Chlorine (Cl) and Bromine (Br) based flame retardants meet JS709B low halogen requirements of <=1000ppm threshold. Antimony trioxide based flame retardants must also meet the <=1000ppm threshold requirement.

- (3) MSL, Peak Temp. - The Moisture Sensitivity Level rating according to the JEDEC industry standard classifications, and peak solder temperature.
- (4) There may be additional marking, which relates to the logo, the lot trace code information, or the environmental category on the device.
- (5) Multiple Device Markings will be inside parentheses. Only one Device Marking contained in parentheses and separated by a "~" will appear on a device. If a line is indented then it is a continuation of the previous line and the two combined represent the entire Device Marking for that device.
- (6) Lead finish/Ball material - Orderable Devices may have multiple material finish options. Finish options are separated by a vertical ruled line. Lead finish/Ball material values may wrap to two lines if the finish value exceeds the maximum column width.

Important Information and Disclaimer:The information provided on this page represents TI's knowledge and belief as of the date that it is provided. TI bases its knowledge and belief on information provided by third parties, and makes no representation or warranty as to the accuracy of such information. Efforts are underway to better integrate information from third parties. TI has taken and continues to take reasonable steps to provide representative and accurate information but may not have conducted destructive testing or chemical analysis on incoming materials and chemicals. TI and TI suppliers consider certain information to be proprietary, and thus CAS numbers and other limited information may not be available for release.

In no event shall TI's liability arising out of such information exceed the total purchase price of the TI part(s) at issue in this document sold by TI to Customer on an annual basis.

TAPE AND REEL INFORMATION

QUADRANT ASSIGNMENTS FOR PIN 1 ORIENTATION IN TAPE

*All dimensions are nominal

| Device | Package Type | Package Drawing | Pins | SPQ | Reel Diameter (mm) | Reel Width W1 (mm) | A0 (mm) | B0 (mm) | K0 (mm) | P1 (mm) | W (mm) | Pin1 Quadrant |
|--------------------|--------------|-----------------|------|------|--------------------|--------------------|---------|---------|---------|---------|--------|---------------|
| MSP430FR2310IPW16R | TSSOP | PW | 16 | 2000 | 330.0 | 12.4 | 6.9 | 5.6 | 1.6 | 8.0 | 12.0 | Q1 |
| MSP430FR2310IPW20R | TSSOP | PW | 20 | 2000 | 330.0 | 16.4 | 6.95 | 7.1 | 1.6 | 8.0 | 16.0 | Q1 |
| MSP430FR2310IRGYR | VQFN | RGY | 16 | 3000 | 330.0 | 12.4 | 3.8 | 4.3 | 1.5 | 8.0 | 12.0 | Q1 |
| MSP430FR2310IRGYT | VQFN | RGY | 16 | 250 | 180.0 | 12.4 | 3.8 | 4.3 | 1.5 | 8.0 | 12.0 | Q1 |
| MSP430FR2311IPW20R | TSSOP | PW | 20 | 2000 | 330.0 | 16.4 | 6.95 | 7.1 | 1.6 | 8.0 | 16.0 | Q1 |
| MSP430FR2311IRGYR | VQFN | RGY | 16 | 3000 | 330.0 | 12.4 | 3.8 | 4.3 | 1.5 | 8.0 | 12.0 | Q1 |
| MSP430FR2311IRGYT | VQFN | RGY | 16 | 250 | 180.0 | 12.4 | 3.8 | 4.3 | 1.5 | 8.0 | 12.0 | Q1 |

TAPE AND REEL BOX DIMENSIONS

*All dimensions are nominal

| Device | Package Type | Package Drawing | Pins | SPQ | Length (mm) | Width (mm) | Height (mm) |
|--------------------|--------------|-----------------|------|------|-------------|------------|-------------|
| MSP430FR2310IPW16R | TSSOP | PW | 16 | 2000 | 350.0 | 350.0 | 43.0 |
| MSP430FR2310IPW20R | TSSOP | PW | 20 | 2000 | 350.0 | 350.0 | 43.0 |
| MSP430FR2310IRGYR | VQFN | RGY | 16 | 3000 | 367.0 | 367.0 | 35.0 |
| MSP430FR2310IRGYT | VQFN | RGY | 16 | 250 | 210.0 | 185.0 | 35.0 |
| MSP430FR2311IPW20R | TSSOP | PW | 20 | 2000 | 350.0 | 350.0 | 43.0 |
| MSP430FR2311IRGYR | VQFN | RGY | 16 | 3000 | 367.0 | 367.0 | 35.0 |
| MSP430FR2311IRGYT | VQFN | RGY | 16 | 250 | 210.0 | 185.0 | 35.0 |

TUBE

*All dimensions are nominal

| Device | Package Name | Package Type | Pins | SPQ | L (mm) | W (mm) | T (μm) | B (mm) |
|-------------------|--------------|--------------|------|-----|--------|--------|--------|--------|
| MSP430FR2310IPW16 | PW | TSSOP | 16 | 90 | 530 | 10.2 | 3600 | 3.5 |
| MSP430FR2310IPW20 | PW | TSSOP | 20 | 70 | 530 | 10.2 | 3600 | 3.5 |
| MSP430FR2311IPW16 | PW | TSSOP | 16 | 90 | 530 | 10.2 | 3600 | 3.5 |
| MSP430FR2311IPW20 | PW | TSSOP | 20 | 70 | 530 | 10.2 | 3600 | 3.5 |

RGY (R-PVQFN-N16)

PLASTIC QUAD FLATPACK NO-LEAD



- NOTES:
- A. All linear dimensions are in millimeters. Dimensioning and tolerancing per ASME Y14.5M-1994.
 - B. This drawing is subject to change without notice.
 - C. QFN (Quad Flatpack No-Lead) package configuration.
 - D. The package thermal pad must be soldered to the board for thermal and mechanical performance.
 - E. See the additional figure in the Product Data Sheet for details regarding the exposed thermal pad features and dimensions.
 - F. Pin 1 identifiers are located on both top and bottom of the package and within the zone indicated. The Pin 1 identifiers are either a molded, marked, or metal feature.
 - G. Package complies to JEDEC MO-241 variation BA.

RGY (R-PVQFN-N16)

PLASTIC QUAD FLATPACK NO-LEAD

THERMAL INFORMATION

This package incorporates an exposed thermal pad that is designed to be attached directly to an external heatsink. The thermal pad must be soldered directly to the printed circuit board (PCB). After soldering, the PCB can be used as a heatsink. In addition, through the use of thermal vias, the thermal pad can be attached directly to the appropriate copper plane shown in the electrical schematic for the device, or alternatively, can be attached to a special heatsink structure designed into the PCB. This design optimizes the heat transfer from the integrated circuit (IC).

For information on the Quad Flatpack No-Lead (QFN) package and its advantages, refer to Application Report, QFN/SON PCB Attachment, Texas Instruments Literature No. SLUA271. This document is available at www.ti.com.

The exposed thermal pad dimensions for this package are shown in the following illustration.



Bottom View

Exposed Thermal Pad Dimensions

4206353-3/P 03/14

NOTE: All linear dimensions are in millimeters

RGY (R-PVQFN-N16)

PLASTIC QUAD FLATPACK NO-LEAD



4208122-3/P 03/14

- NOTES:
- A. All linear dimensions are in millimeters.
 - B. This drawing is subject to change without notice.
 - C. Publication IPC-7351 is recommended for alternate designs.
 - D. This package is designed to be soldered to a thermal pad on the board. Refer to Application Note, Quad Flat-Pack QFN/SON PCB Attachment, Texas Instruments Literature No. SLUA271, and also the Product Data Sheets for specific thermal information, via requirements, and recommended board layout. These documents are available at www.ti.com <<http://www.ti.com>>.
 - E. Laser cutting apertures with trapezoidal walls and also rounding corners will offer better paste release. Customers should contact their board assembly site for stencil design recommendations. Refer to IPC 7525 for stencil design considerations.
 - F. Customers should contact their board fabrication site for minimum solder mask web tolerances between signal pads.



4220206/A 02/2017

NOTES:

1. All linear dimensions are in millimeters. Any dimensions in parenthesis are for reference only. Dimensioning and tolerancing per ASME Y14.5M.
2. This drawing is subject to change without notice.
3. This dimension does not include mold flash, protrusions, or gate burrs. Mold flash, protrusions, or gate burrs shall not exceed 0.15 mm per side.
4. This dimension does not include interlead flash. Interlead flash shall not exceed 0.25 mm per side.
5. Reference JEDEC registration MO-153.

EXAMPLE BOARD LAYOUT

PW0020A

TSSOP - 1.2 mm max height

SMALL OUTLINE PACKAGE



LAND PATTERN EXAMPLE
EXPOSED METAL SHOWN
SCALE: 10X



SOLDER MASK DETAILS

4220206/A 02/2017

NOTES: (continued)

- 6. Publication IPC-7351 may have alternate designs.
- 7. Solder mask tolerances between and around signal pads can vary based on board fabrication site.

EXAMPLE STENCIL DESIGN

PW0020A

TSSOP - 1.2 mm max height

SMALL OUTLINE PACKAGE



SOLDER PASTE EXAMPLE
BASED ON 0.125 mm THICK STENCIL
SCALE: 10X

4220206/A 02/2017

NOTES: (continued)

8. Laser cutting apertures with trapezoidal walls and rounded corners may offer better paste release. IPC-7525 may have alternate design recommendations.
9. Board assembly site may have different recommendations for stencil design.

PW (R-PDSO-G20)

PLASTIC SMALL OUTLINE



- NOTES:
- A. All linear dimensions are in millimeters.
 - B. This drawing is subject to change without notice.
 - C. Publication IPC-7351 is recommended for alternate design.
 - D. Laser cutting apertures with trapezoidal walls and also rounding corners will offer better paste release. Customers should contact their board assembly site for stencil design recommendations. Refer to IPC-7525 for other stencil recommendations.
 - E. Customers should contact their board fabrication site for solder mask tolerances between and around signal pads.



4220204/A 02/2017

NOTES:

1. All linear dimensions are in millimeters. Any dimensions in parenthesis are for reference only. Dimensioning and tolerancing per ASME Y14.5M.
2. This drawing is subject to change without notice.
3. This dimension does not include mold flash, protrusions, or gate burrs. Mold flash, protrusions, or gate burrs shall not exceed 0.15 mm per side.
4. This dimension does not include interlead flash. Interlead flash shall not exceed 0.25 mm per side.
5. Reference JEDEC registration MO-153.

EXAMPLE BOARD LAYOUT

PW0016A

TSSOP - 1.2 mm max height

SMALL OUTLINE PACKAGE



LAND PATTERN EXAMPLE
EXPOSED METAL SHOWN
SCALE: 10X



SOLDER MASK DETAILS

4220204/A 02/2017

NOTES: (continued)

- 6. Publication IPC-7351 may have alternate designs.
- 7. Solder mask tolerances between and around signal pads can vary based on board fabrication site.

EXAMPLE STENCIL DESIGN

PW0016A

TSSOP - 1.2 mm max height

SMALL OUTLINE PACKAGE



SOLDER PASTE EXAMPLE
BASED ON 0.125 mm THICK STENCIL
SCALE: 10X

4220204/A 02/2017

NOTES: (continued)

8. Laser cutting apertures with trapezoidal walls and rounded corners may offer better paste release. IPC-7525 may have alternate design recommendations.
9. Board assembly site may have different recommendations for stencil design.

重要声明和免责声明

TI“按原样”提供技术和可靠性数据（包括数据表）、设计资源（包括参考设计）、应用或其他设计建议、网络工具、安全信息和其他资源，不保证没有瑕疵且不做任何明示或暗示的担保，包括但不限于对适销性、某特定用途方面的适用性或不侵犯任何第三方知识产权的暗示担保。

这些资源可供使用 TI 产品进行设计的熟练开发人员使用。您将自行承担以下全部责任：(1) 针对您的应用选择合适的 TI 产品，(2) 设计、验证并测试您的应用，(3) 确保您的应用满足相应标准以及任何其他功能安全、信息安全、监管或其他要求。

这些资源如有变更，恕不另行通知。TI 授权您仅可将这些资源用于研发本资源所述的 TI 产品的应用。严禁对这些资源进行其他复制或展示。您无权使用任何其他 TI 知识产权或任何第三方知识产权。您应全额赔偿因在这些资源的使用中对 TI 及其代表造成的任何索赔、损害、成本、损失和债务，TI 对此概不负责。

TI 提供的产品受 [TI 的销售条款](#) 或 [ti.com](#) 上其他适用条款/TI 产品随附的其他适用条款的约束。TI 提供这些资源并不会扩展或以其他方式更改 TI 针对 TI 产品发布的适用的担保或担保免责声明。

TI 反对并拒绝您可能提出的任何其他或不同的条款。

邮寄地址：Texas Instruments, Post Office Box 655303, Dallas, Texas 75265

Copyright © 2023，德州仪器 (TI) 公司

X-ON Electronics

Largest Supplier of Electrical and Electronic Components

Click to view similar products for [16-bit Microcontrollers - MCU category:](#)

Click to view products by [Texas Instruments manufacturer:](#)

Other Similar products are found below :

[M30302FCFP#U3](#) [MB96F683RBPMC-GSAE1](#) [R5F111PGGFB#30](#) [R5F107DEGSP#X0](#) [R5F21172DSP#U0](#) [MB90F568PMCR-GE1](#)
[MB96F387RSBPMC-GS-N2E2](#) [MB96F018RBPMC-GSE1](#) [R5F2135CCDFP#30](#) [MB90F548GPF-GE1](#) [MB90F395HAPMCR-GS-SPE2](#)
[MB96F395RWAPMC-GSE2](#) [CY90F497GPMC-GE1](#) [MB96F693RBPMC-GSE1](#) [SAK-XC2287-96F80L AC](#) [ST10F280](#)
[MB96F338RSAPMCR-GK5E2](#) [CY90096PF-G-002-BND-ERE1](#) [R5F21236JFP#U1](#) [R5F21104DFP#U0](#) [R5F10WLCAFB#30](#)
[R5F10WLCAFB#50](#) [M30291FCHP#U7A](#) [R5F111MGGFB#30](#) [R5F104LEAFB#10](#) [R5F10RF8AFP#10](#) [R5F104MGGFB#10](#)
[R5F104MHAF#10](#) [R5F140LKAFB#30](#) [R5F140LLGFB#30](#) [R5F1176AGSM#30](#) [R5F10369ASM#35](#) [R5F10KBCGFP#V0](#)
[R5F10EGDGFB#V0](#) [R5F104FDAFP#10](#) [R5F104GAAFB#10](#) [R5F104LFAFB#10](#) [R5F10WMGGFB#10](#) [R5F140PLGFB#30](#)
[R5F10266GSP#35](#) [R5F11BBCGFP#30](#) [R5F110PJGFB#30](#) [R5F10266ASM#35](#) [R5F10267GSM#35](#) [R5F10WLF#30](#)
[R5F10WLA#30](#) [R5F10RLAGNB#20](#) [R5F1026AGSP#35](#) [R5F10268GSP#35](#) [R5F1026AGSP#55](#)