



1.8V, 700nA, Zero-Crossover RAIL-TO-RAIL I/O OPERATIONAL AMPLIFIER

FEATURES

- **nanoPOWER:**
 - OPA369: 800nA
 - OPA2369: 700nA/ch.
- **LOW OFFSET VOLTAGE: 250 μ V**
 - ZERO-CROSSOVER
- **LOW OFFSET DRIFT: 0.4 μ V/ $^{\circ}$ C**
- **DC PRECISION:**
 - CMRR: 114dB
 - PSRR: 106dB
 - AOL: 134dB
- **GAIN-BANDWIDTH PRODUCT: 12kHz**
- **SUPPLY VOLTAGE: 1.8V to 5.5V**
- **microSIZE PACKAGES:**
 - SC70-5, SOT23-5, MSOP-8

DESCRIPTION

The OPA369 and OPA2369 are ultra-low-power, low-voltage operational amplifiers from Texas Instruments designed especially for battery-powered applications.

The OPA369 operates on a supply voltage as low as 1.8V and has true rail-to-rail operation that makes it useful for a wide range of applications. The *zero-crossover* feature resolves the problem of input crossover distortion that becomes very prominent in low voltage (< 3V), rail-to-rail input applications.

In addition to *microsize* packages and very low quiescent current, the OPA369 features 12kHz bandwidth, low offset drift (1.75 μ V/ $^{\circ}$ C, max), and low noise 3.6 μ V_{PP} (0.1Hz to 10Hz).

The OPA369 (single version) is offered in an SC70-5 package. The OPA2369 (dual version) comes in both MSOP-8 and SOT23-8 packages.

APPLICATIONS

- BATTERY-POWERED INSTRUMENTS
- PORTABLE DEVICES
- MEDICAL INSTRUMENTS
- TEST EQUIPMENT
- LOW-POWER SENSOR SIGNAL CONDITIONING

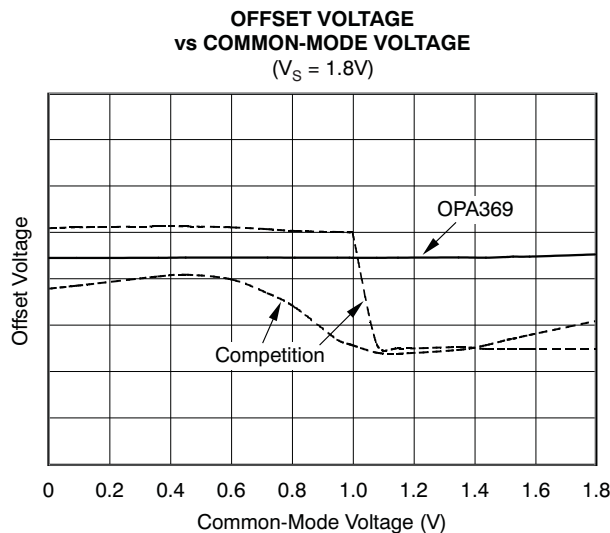

Please be aware that an important notice concerning availability, standard warranty, and use in critical applications of Texas Instruments semiconductor products and disclaimers thereto appears at the end of this data sheet.

All trademarks are the property of their respective owners.



This integrated circuit can be damaged by ESD. Texas Instruments recommends that all integrated circuits be handled with appropriate precautions. Failure to observe proper handling and installation procedures can cause damage.

ESD damage can range from subtle performance degradation to complete device failure. Precision integrated circuits may be more susceptible to damage because very small parametric changes could cause the device not to meet its published specifications.

ABSOLUTE MAXIMUM RATINGS⁽¹⁾

Over operating free-air temperature range (unless otherwise noted).

		VALUE	UNIT
Supply Voltage $V_S = (V+) - (V-)$		+7	V
Single Input Terminals	Voltage ⁽²⁾	$(V-) - 0.5$ to $(V+) + 0.5$	V
	Current ⁽²⁾	± 10	mA
Output Short-Circuit ⁽³⁾		Continuous	
Ambient Operating Temperature		-55 to +125	°C
Ambient Storage Temperature		-65 to +150	°C
Junction Temperature T_J		+150	°C
ESD Ratings	Human Body Model (HBM)	4000	V
	Charged Device Model (CDM)	1000	V
	Machine Model (MM)	200	V

- (1) Stresses above these ratings may cause permanent damage. Exposure to absolute maximum conditions for extended periods may degrade device reliability. These are stress ratings only, and functional operation of the device at these or any other conditions beyond those specified is not supported.
- (2) Input terminals are diode-clamped to the power-supply rails. Input signals that can swing more than 0.5V beyond the supply rails should be current limited to 10mA or less.
- (3) Short-circuit to $V_S/2$, one amplifier per package.

PACKAGE/ORDERING INFORMATION⁽¹⁾

PRODUCT	PACKAGE-LEAD	PACKAGE DESIGNATOR	PACKAGE MARKING
OPA369	SC70-5	DCK	CJS
OPA2369	MSOP-8	DGK	OCCQ
	SOT23-8	DCN	OCBQ

- (1) For the most current package and ordering information see the Package Option Addendum at the end of this document, or see the TI web site at www.ti.com.

PIN CONFIGURATIONS

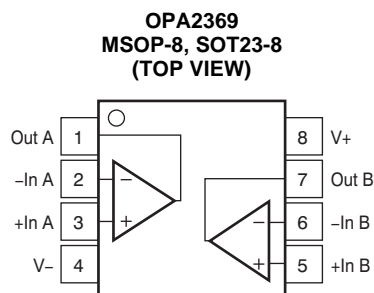
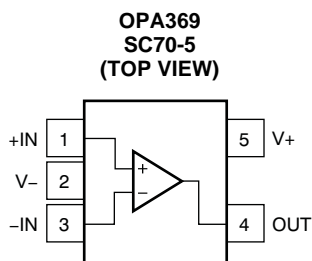

ELECTRICAL CHARACTERISTICS: $V_S = +1.8V$ to $+5.5V$
BOLDFACE limits apply over the specified temperature range, $T_A = -40^\circ\text{C}$ to $+85^\circ\text{C}$.

 At $T_A = +25^\circ\text{C}$, and $R_L = 100\text{k}\Omega$ connected to $V_S/2$, unless otherwise noted.

PARAMETER	CONDITIONS	OPA369, OPA2369			UNIT
		MIN	TYP	MAX	
OFFSET VOLTAGE					
Input Offset Voltage	V_{OS}		250	750	μV
over Temperature				1	mV
Drift	dV_{OS}/dT		0.4	1.75	$\mu\text{V}/^\circ\text{C}$
vs Power Supply	PSRR	$V_S = 1.8V$ to $5.5V$	5	20	$\mu\text{V}/V$
Channel Separation	dc		140		dB
	f = 1kHz		120		dB
INPUT VOLTAGE RANGE					
Common-Mode Voltage Range	V_{CM}	(V–)		(V+)	V
Common-Mode Rejection Ratio	CMRR	$(V-) \leq V_{CM} \leq (V+)$	100	114	dB
over Temperature		$(V-) \leq V_{CM} \leq (V+)$	90		dB
INPUT BIAS CURRENT					
Input Bias Current	I_B		10	50	pA
over Temperature			See Figure 16		pA
Input Offset Current	I_{OS}		10	50	pA
INPUT IMPEDANCE					
Differential			$10^{13} \parallel 3$		$\Omega \parallel \text{pF}$
Common-Mode			$10^{13} \parallel 6$		$\Omega \parallel \text{pF}$
NOISE					
Input Voltage Noise		f = 0.1Hz to 10Hz	3.6		μV_{PP}
Input Voltage Noise Density		f = 100Hz	220		$\text{nV}/\sqrt{\text{Hz}}$
		f = 1kHz	290		$\text{nV}/\sqrt{\text{Hz}}$
Current Noise Density		f = 1kHz	1		$\text{fA}/\sqrt{\text{Hz}}$
OPEN-LOOP GAIN					
Open-Loop Voltage Gain	A_{OL}	$100\text{mV} \leq V_O \leq (V+)-100\text{mV}$, $R_L = 100\text{k}\Omega$	114	134	dB
Over Temperature		$100\text{mV} \leq V_O \leq (V+)-100\text{mV}$, $R_L = 100\text{k}\Omega$	100		dB
		$500\text{mV} \leq V_O \leq (V+)-500\text{mV}$, $R_L = 10\text{k}\Omega$	114	134	dB
Over Temperature		$500\text{mV} \leq V_O \leq (V+)-500\text{mV}$, $R_L = 10\text{k}\Omega$	90		dB
OUTPUT					
Voltage Output Swing from Rail		$R_L = 100\text{k}\Omega$ $R_L = 10\text{k}\Omega$		10 25	mV mV
Short-Circuit Current	I_{SC}		10		mA
Capacitive Load Drive	C_{LOAD}		See Figure 20		pF
FREQUENCY RESPONSE					
Gain-Bandwidth Product	GBW		12		kHz
Slew Rate	SR	G = +1	0.005		V/ μs
Overload Recovery Time		$V_{IN} \times \text{Gain} > V_S$	250		μs

ELECTRICAL CHARACTERISTICS: $V_S = +1.8V$ to $+5.5V$ (continued)

BOLDFACE limits apply over the specified temperature range, $T_A = -40^\circ C$ to $+85^\circ C$.

At $T_A = +25^\circ C$, and $R_L = 100k\Omega$ connected to $V_S/2$, unless otherwise noted.

PARAMETER	CONDITIONS	OPA369, OPA2369			UNIT
		MIN	TYP	MAX	
POWER SUPPLY					
Specified Voltage	V_S	1.8		5.5	V
Quiescent Current	I_Q				
OPA369	$I_{OUT} = 0A$		0.8	1.2	μA
OPA2369 (per channel)			0.7	1	μA
Over Temperature					
OPA369				1.45	μA
OPA2369 (per channel)				1.25	μA
TEMPERATURE RANGE					
Specified Range	T_A	-40		+85	$^\circ C$
Operating Range	T_A	-55		+125	$^\circ C$
Thermal Resistance	θ_{JA}				
SC70			250		$^\circ C/W$
SOT23			223		$^\circ C/W$
MSOP			252		$^\circ C/W$

TYPICAL CHARACTERISTICS

At $T_A = +25^\circ\text{C}$, $V_S = 5\text{V}$, and $R_L = 100\text{k}\Omega$ connected to $V_S/2$, unless otherwise noted.

OFFSET VOLTAGE PRODUCTION DISTRIBUTION

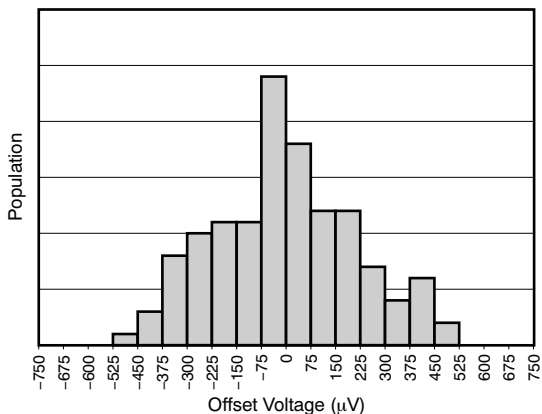

Figure 1.

OFFSET VOLTAGE DRIFT PRODUCTION DISTRIBUTION

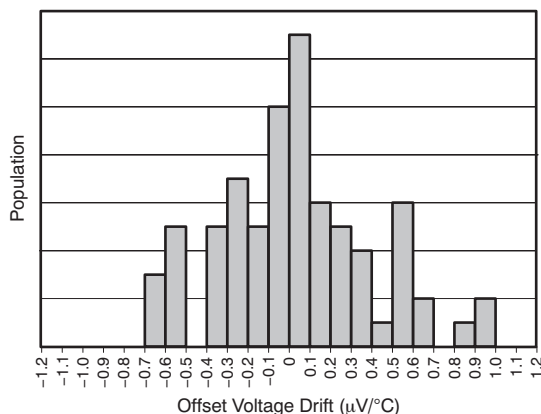

Figure 2.

OFFSET VOLTAGE vs TEMPERATURE

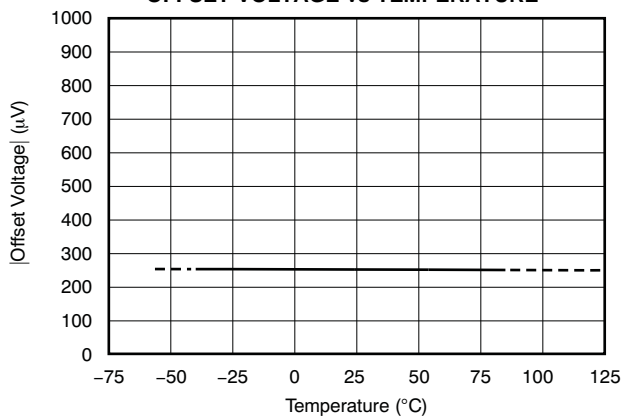

Figure 3.

NORMALIZED OFFSET VOLTAGE vs COMMON-MODE VOLTAGE

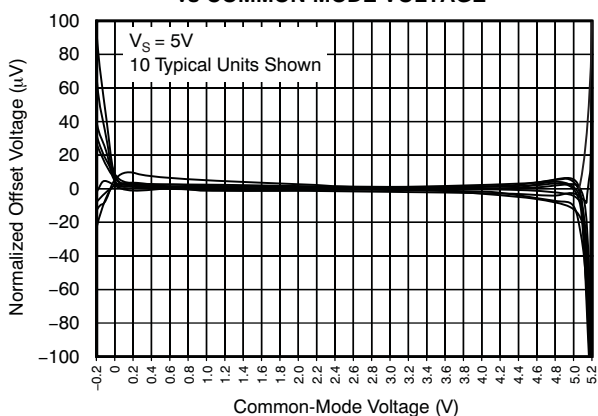

Figure 4.

0.1Hz to 10Hz NOISE

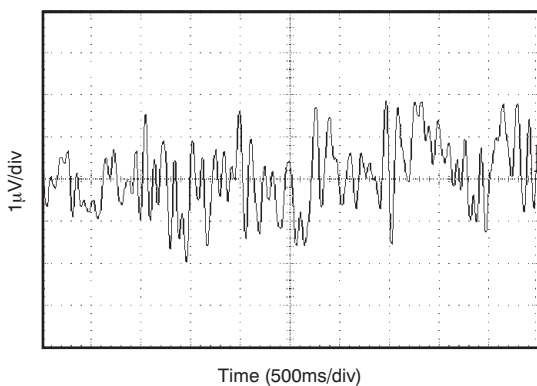

Figure 5.

INPUT-REFERRED VOLTAGE NOISE vs FREQUENCY

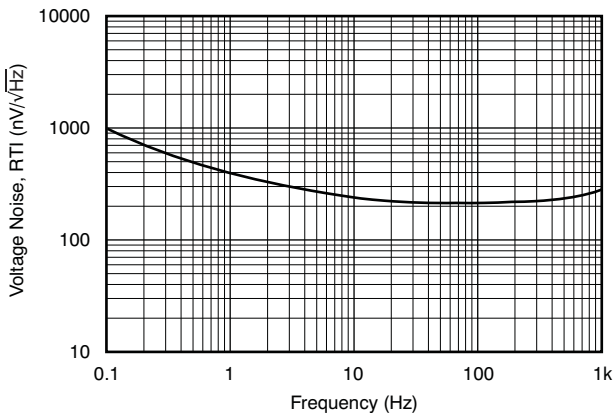

Figure 6.

TYPICAL CHARACTERISTICS (continued)

At $T_A = +25^\circ\text{C}$, $V_S = 5\text{V}$, and $R_L = 100\text{k}\Omega$ connected to $V_S/2$, unless otherwise noted.

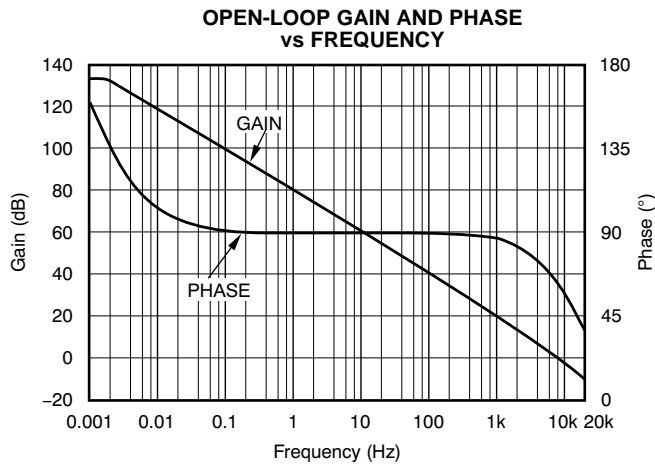

Figure 7.

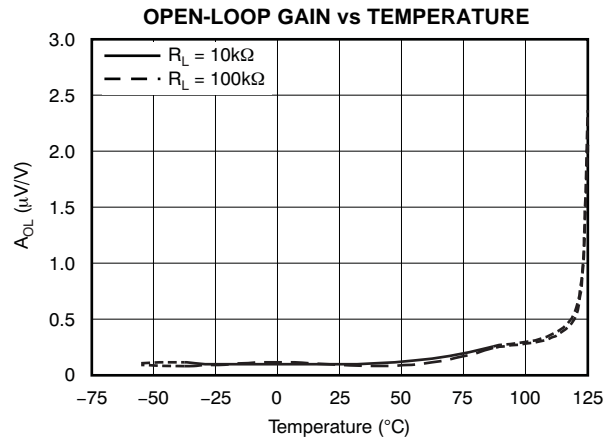

Figure 8.

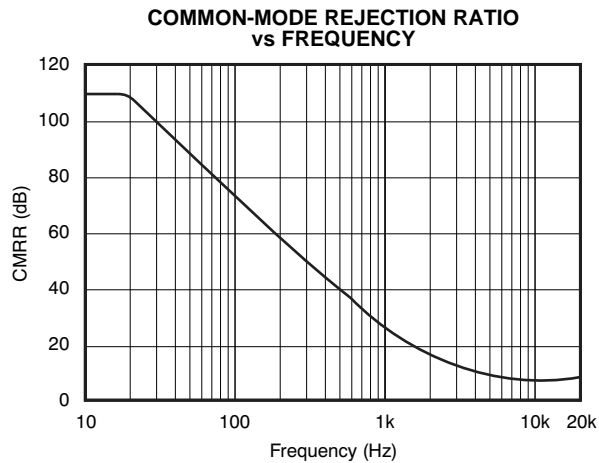

Figure 9.

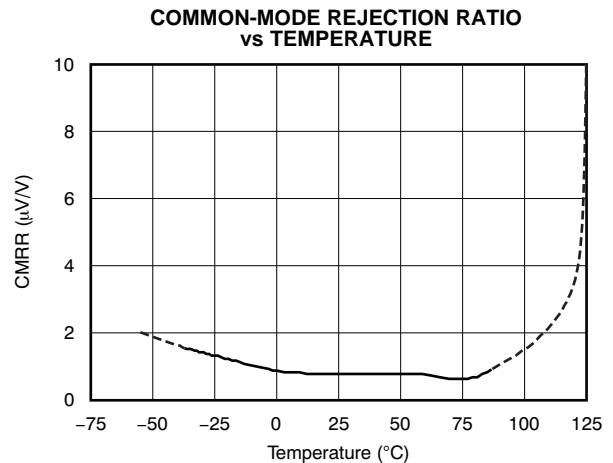

Figure 10.

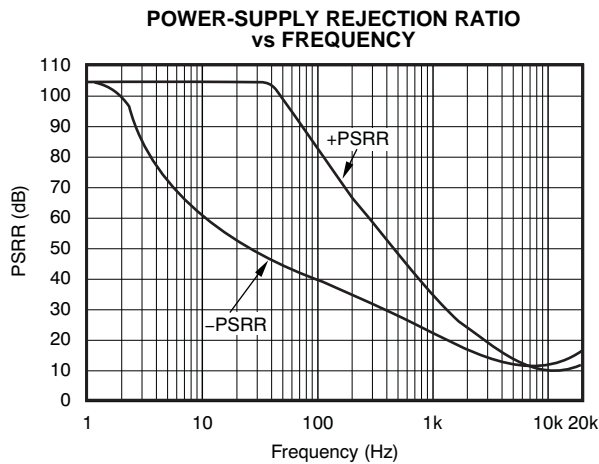

Figure 11.

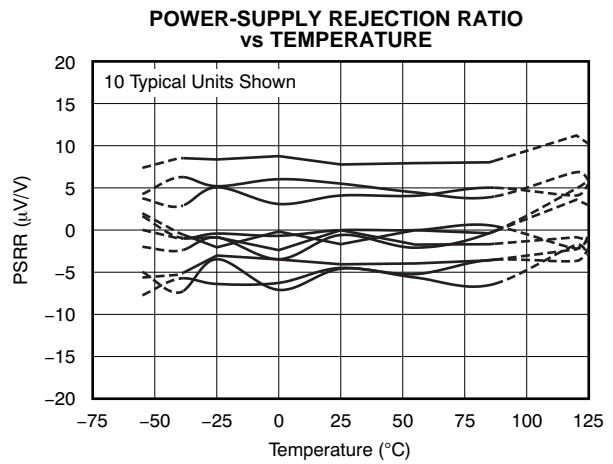

Figure 12.

TYPICAL CHARACTERISTICS (continued)

At $T_A = +25^\circ\text{C}$, $V_S = 5\text{V}$, and $R_L = 100\text{k}\Omega$ connected to $V_S/2$, unless otherwise noted.

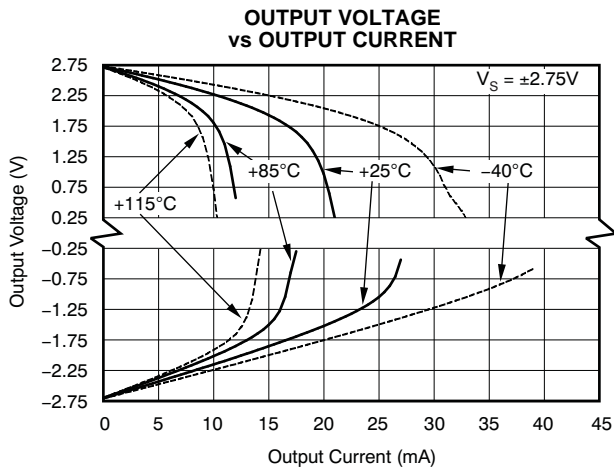

Figure 13.

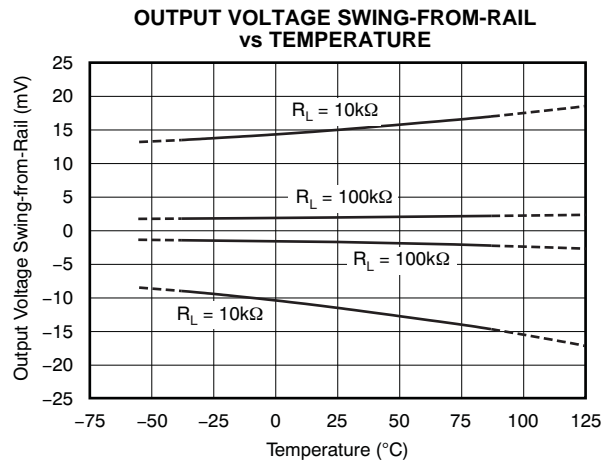

Figure 14.

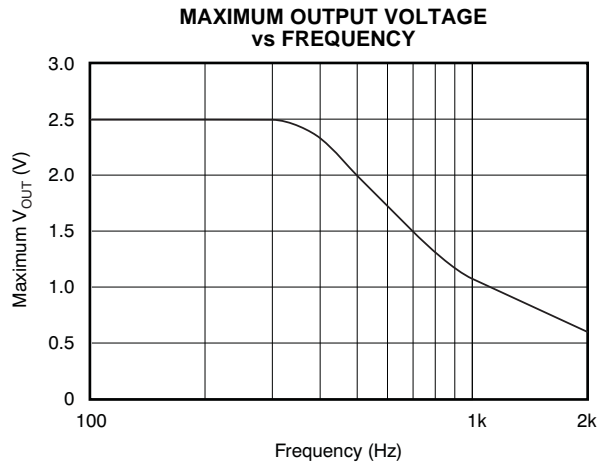

Figure 15.

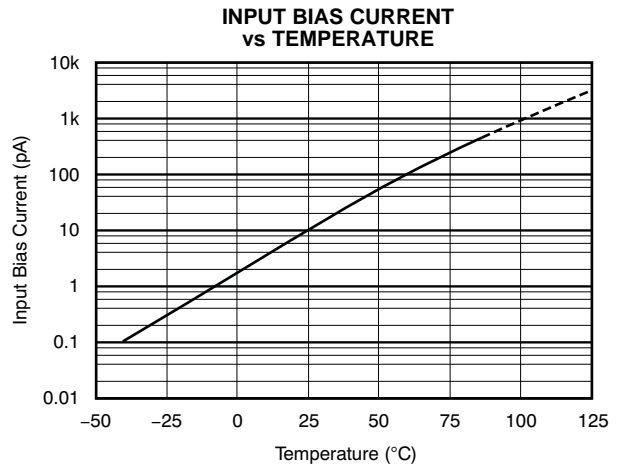

Figure 16.

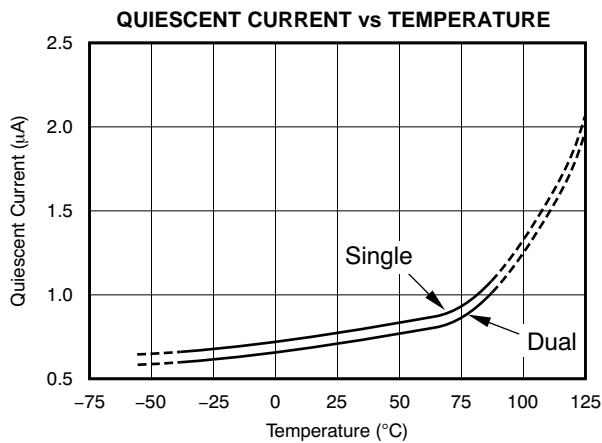

Figure 17.

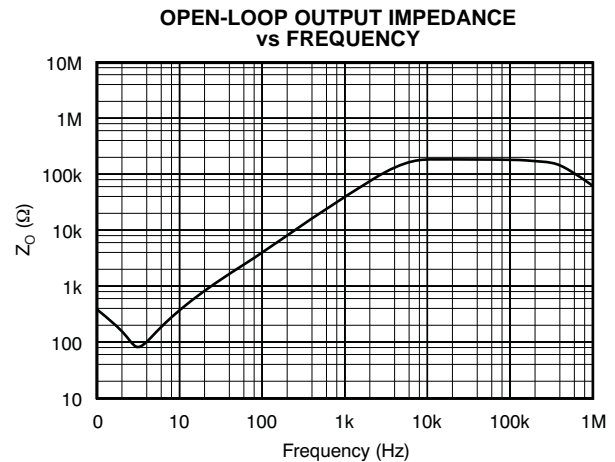

Figure 18.

TYPICAL CHARACTERISTICS (continued)

At $T_A = +25^\circ\text{C}$, $V_S = 5\text{V}$, and $R_L = 100\text{k}\Omega$ connected to $V_S/2$, unless otherwise noted.

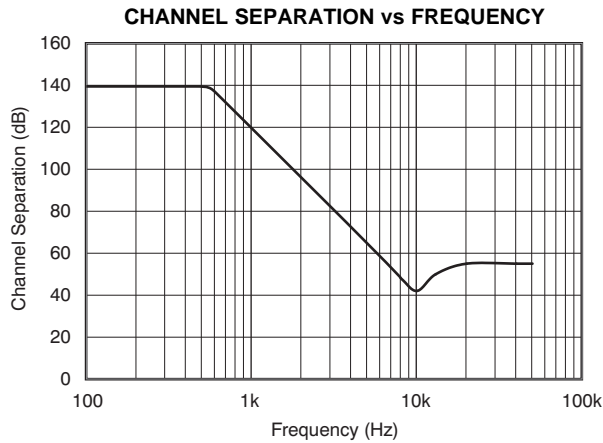

Figure 19.

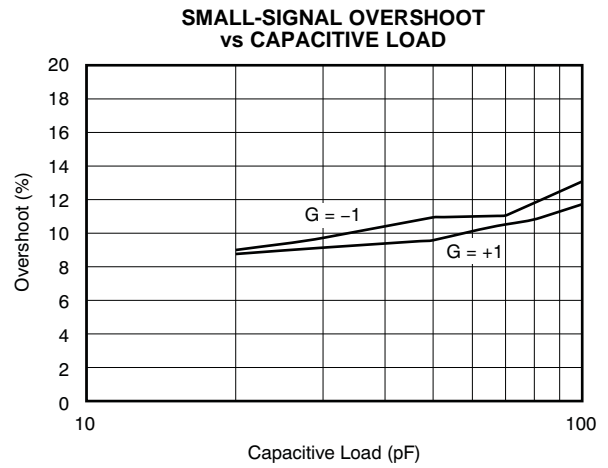

Figure 20.

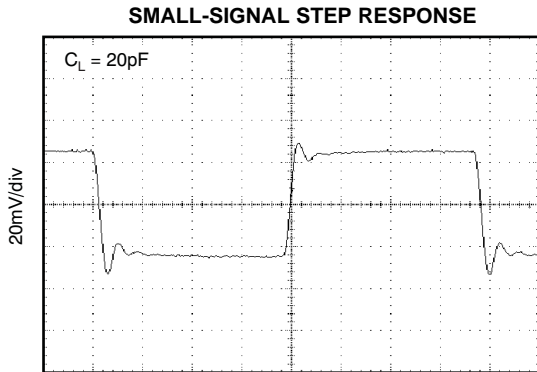

Figure 21.

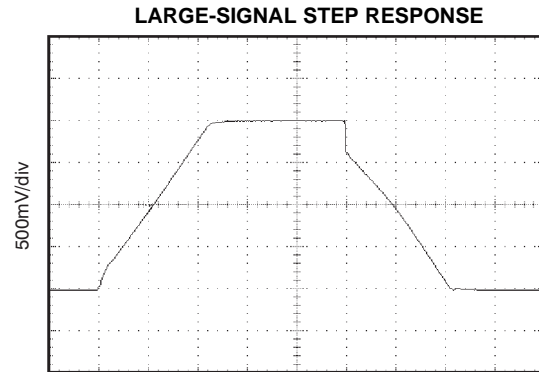

Figure 22.

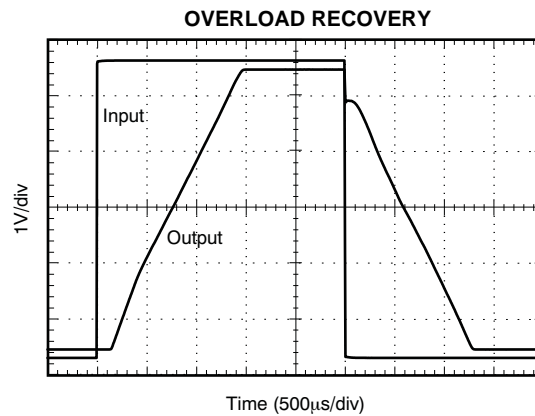

Figure 23.

APPLICATION INFORMATION

The OPA369 family of operational amplifiers minimizes power consumption and operates on supply voltages as low as 1.8V. Power-supply rejection ratio (PSRR), common-mode rejection ratio (CMRR), and open-loop gain (A_{OL}) typical values are in the range of 100dB or better.

When designing for ultralow power, choose system components carefully. To minimize current consumption, select large-value resistors. Any resistors will react with stray capacitance in the circuit and the input capacitance of the operational amplifier. These parasitic RC combinations can affect the stability of the overall system. A feedback capacitor may be required to assure stability and limit overshoot or gain peaking.

Good layout practice mandates the use of a 0.1 μ F bypass capacitor placed closely across the supply pins.

OPERATING VOLTAGE

OPA369 series op amps are fully specified and tested from +1.8V to +5.5V ($\pm 0.9V$ to $\pm 2.75V$). Parameters that vary significantly with supply voltage are shown in the [Typical Characteristic](#) curves.

INPUT COMMON-MODE VOLTAGE RANGE

The OPA369 family is designed to eliminate the input offset transition region typically present in most rail-to-rail complementary stage operational amplifiers, which allows the OPA369 family of amplifiers to provide superior common-mode performance over the entire input range.

The input common-mode voltage range of the OPA369 family typically extends to each supply rail. CMRR is specified from the negative rail to the positive rail. See [Figure 4](#), *Normalized Offset Voltage vs Common-Mode Voltage*.

PROTECTING INPUTS FROM OVER-VOLTAGE

Input currents are typically 10pA. However, large inputs (greater than 500mV beyond the supply rails) can cause excessive current to flow in or out of the input pins. Therefore, in addition to keeping the input voltage between the supply rails, it is also important to limit the input current to less than 10mA. This limiting is easily accomplished with an input resistor, as shown in [Figure 24](#).

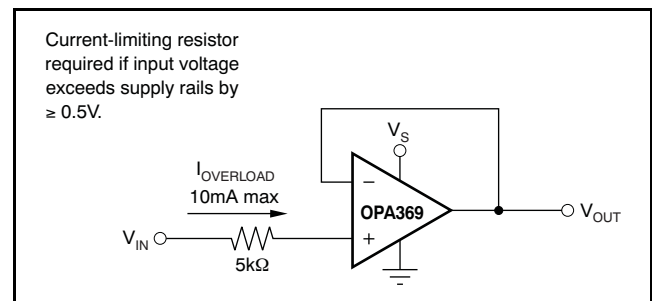

Figure 24. Input Current Protection for Voltages Exceeding the Supply Voltage

BATTERY MONITORING

The low operating voltage and quiescent current of the OPA369 series make it an excellent choice for battery monitoring applications, as shown in Figure 25. In this circuit, V_{STATUS} is high as long as the battery voltage remains above 2V. A low-power reference is used to set the trip point. Resistor values are selected as follows:

1. Selecting R_F : Select R_F such that the current through R_F is approximately 1000x larger than the maximum bias current over temperature:

$$R_F = \frac{V_{REF}}{1000(I_{BMAX})}$$

$$= \frac{1.2V}{1000(50pA)}$$

$$= 24M\Omega \approx 20M\Omega \quad (1)$$

2. Choose the hysteresis voltage, V_{HYST} . For battery-monitoring applications, 50mV is adequate.

3. Calculate R_1 as follows:

$$R_1 = R_F \left[\frac{V_{HYST}}{V_{BATT}} \right] = 20M\Omega \left[\frac{50mV}{2.4V} \right] = 420k\Omega \quad (2)$$

4. Select a threshold voltage for V_{IN} rising (V_{THRS}) = 2.0V

5. Calculate R_2 as follows:

$$R_2 = \frac{1}{\left[\left(\frac{V_{THRS}}{V_{REF} \times R_1} \right) - \frac{1}{R_1} - \frac{1}{R_F} \right]}$$

$$= \frac{1}{\left[\left(\frac{2V}{1.2V \times 420k\Omega} \right) - \frac{1}{420k\Omega} - \frac{1}{20M\Omega} \right]}$$

$$= 650k\Omega \quad (3)$$

6. Calculate R_{BIAS} : The minimum supply voltage for this circuit is 1.8V. The REF1112 has a current requirement of 1.2μA (max). Providing the REF1112 with 2μA of supply current assures proper operation. Therefore:

$$R_{BIAS} = \frac{(V_{BATTMIN} - V_{REF})}{I_{BIAS}} = \frac{(1.8V - 1.2V)}{2\mu A} = 0.3M\Omega \quad (4)$$

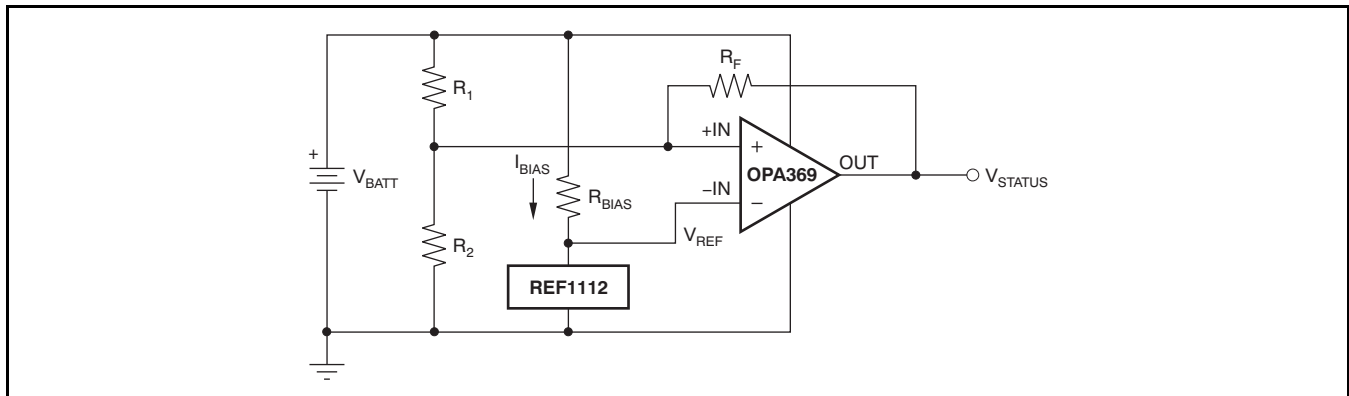

Figure 25. Battery Monitor

WINDOW COMPARATOR

Figure 26 shows the OPA2369 used as a window comparator. The threshold limits are set by V_H and V_L , with $V_H > V_L$. When $V_{IN} < V_H$, the output of A1 is low. When $V_{IN} > V_L$, the output of A2 is low. Therefore, both op amp outputs are at 0V as long as V_{IN} is between V_H and V_L . This architecture results in no current flowing through either diode, Q1 in cutoff, with the base voltage at 0V, and V_{OUT} forced high.

If V_{IN} falls below V_L , the output of A2 is high, current flows through D2, and V_{OUT} is low. Likewise, if V_{IN} rises above V_H , the output of A1 is high, current flows through D1, and V_{OUT} is low. The window comparator threshold voltages are set as follows:

$$V_H = \frac{R_2}{R_1 + R_2} \times V_S \quad (5)$$

$$V_L = \frac{R_4}{R_3 + R_4} \times V_S \quad (6)$$

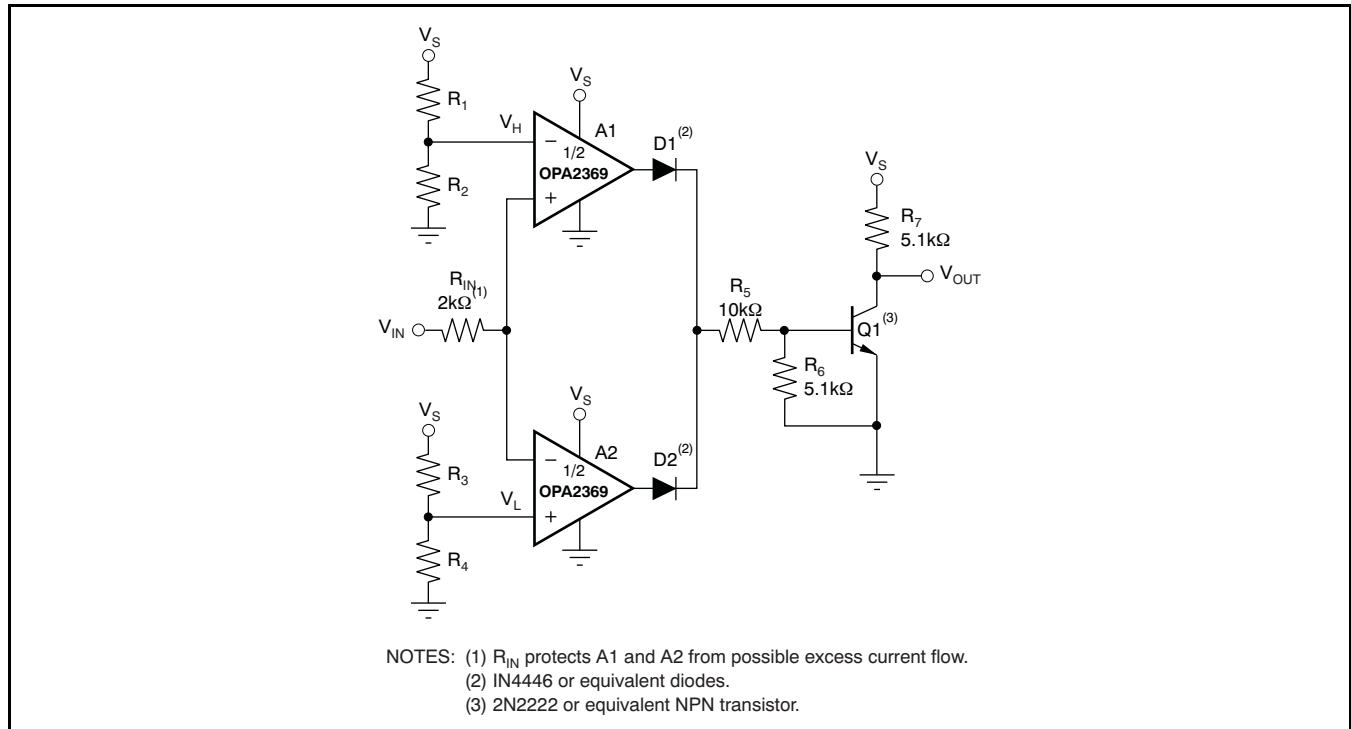

Figure 26. OPA2369 as a Window Comparator

ADDITIONAL APPLICATION EXAMPLES

Figure 27 through Figure 29 illustrate additional application examples.

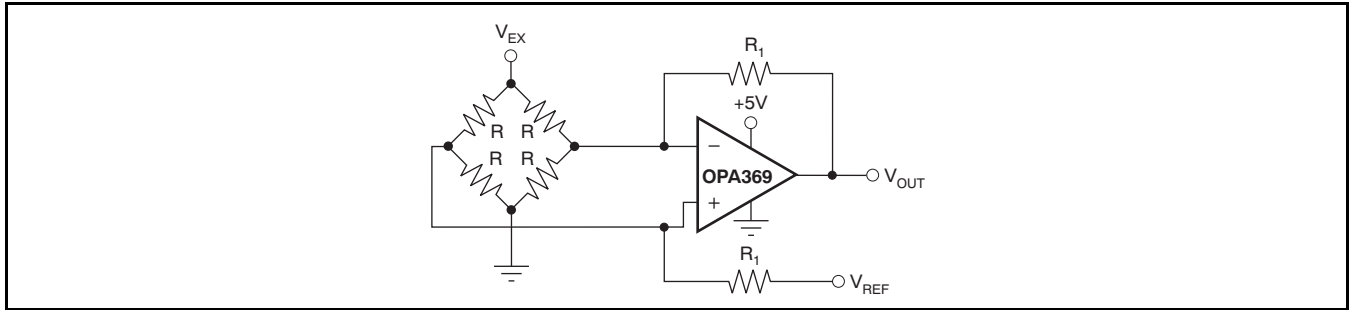

Figure 27. Single Op Amp Bridge Amplifier

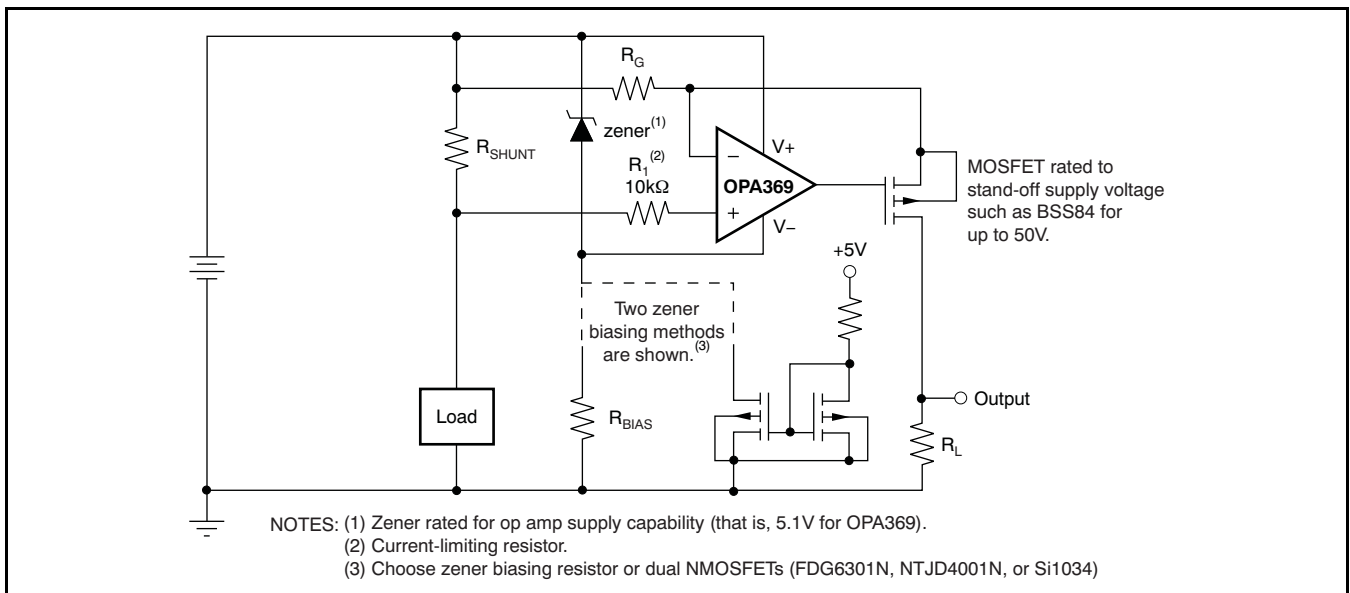

Figure 28. High-Side Current Monitor

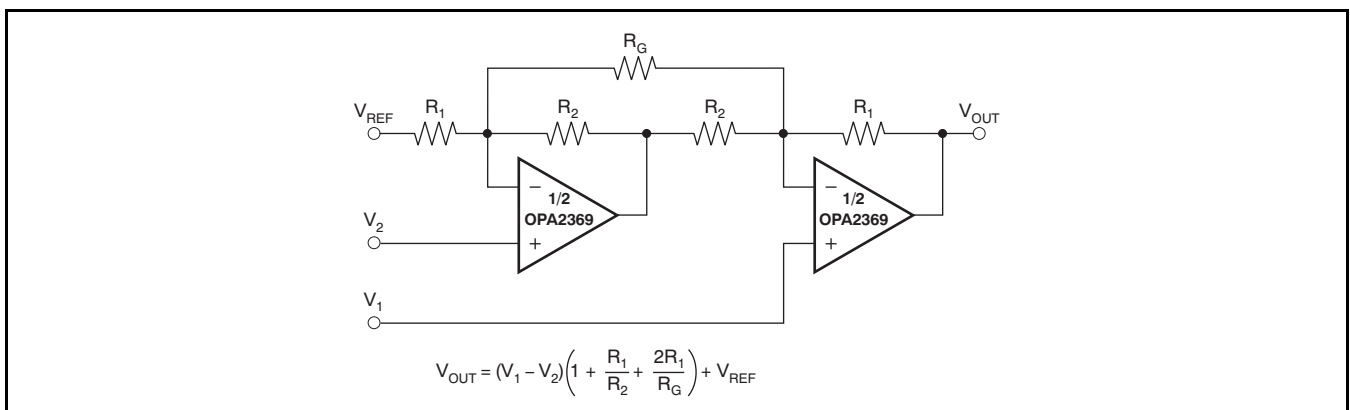

Figure 29. Two Op Amp Instrumentation Amplifier

PACKAGING INFORMATION

Orderable Device	Status (1)	Package Type	Package Drawing	Pins	Package Qty	Eco Plan (2)	Lead finish/ Ball material (6)	MSL Peak Temp (3)	Op Temp (°C)	Device Marking (4/5)	Samples
OPA2369AIDCNR	ACTIVE	SOT-23	DCN	8	3000	RoHS & Green	NIPDAU	Level-2-260C-1 YEAR	-40 to 85	OCBQ	Samples
OPA2369AIDCNRG4	ACTIVE	SOT-23	DCN	8	3000	RoHS & Green	NIPDAU	Level-2-260C-1 YEAR	-40 to 85	OCBQ	Samples
OPA2369AIDCNT	ACTIVE	SOT-23	DCN	8	250	RoHS & Green	NIPDAU	Level-2-260C-1 YEAR	-40 to 85	OCBQ	Samples
OPA2369AIDGKR	ACTIVE	VSSOP	DGK	8	2500	RoHS & Green	Call TI NIPDAUAG NIPDAU	Level-2-260C-1 YEAR	-40 to 85	OCCQ	Samples
OPA2369AIDGKT	ACTIVE	VSSOP	DGK	8	250	RoHS & Green	Call TI NIPDAUAG NIPDAU	Level-2-260C-1 YEAR	-40 to 85	OCCQ	Samples
OPA2369AIDGKTG4	ACTIVE	VSSOP	DGK	8	250	RoHS & Green	Call TI	Level-2-260C-1 YEAR	-40 to 85	OCCQ	Samples
OPA369AIDCKR	ACTIVE	SC70	DCK	5	3000	RoHS & Green	NIPDAU	Level-2-260C-1 YEAR	-40 to 85	CJS	Samples
OPA369AIDCKT	ACTIVE	SC70	DCK	5	250	RoHS & Green	NIPDAU	Level-2-260C-1 YEAR	-40 to 85	CJS	Samples

(1) The marketing status values are defined as follows:

ACTIVE: Product device recommended for new designs.

LIFEBUY: TI has announced that the device will be discontinued, and a lifetime-buy period is in effect.

NRND: Not recommended for new designs. Device is in production to support existing customers, but TI does not recommend using this part in a new design.

PREVIEW: Device has been announced but is not in production. Samples may or may not be available.

OBSELETE: TI has discontinued the production of the device.

(2) **RoHS:** TI defines "RoHS" to mean semiconductor products that are compliant with the current EU RoHS requirements for all 10 RoHS substances, including the requirement that RoHS substance do not exceed 0.1% by weight in homogeneous materials. Where designed to be soldered at high temperatures, "RoHS" products are suitable for use in specified lead-free processes. TI may reference these types of products as "Pb-Free".

RoHS Exempt: TI defines "RoHS Exempt" to mean products that contain lead but are compliant with EU RoHS pursuant to a specific EU RoHS exemption.

Green: TI defines "Green" to mean the content of Chlorine (Cl) and Bromine (Br) based flame retardants meet JS709B low halogen requirements of <=1000ppm threshold. Antimony trioxide based flame retardants must also meet the <=1000ppm threshold requirement.

(3) MSL, Peak Temp. - The Moisture Sensitivity Level rating according to the JEDEC industry standard classifications, and peak solder temperature.

(4) There may be additional marking, which relates to the logo, the lot trace code information, or the environmental category on the device.

(5) Multiple Device Markings will be inside parentheses. Only one Device Marking contained in parentheses and separated by a "~" will appear on a device. If a line is indented then it is a continuation of the previous line and the two combined represent the entire Device Marking for that device.

⁽⁶⁾ Lead finish/Ball material - Orderable Devices may have multiple material finish options. Finish options are separated by a vertical ruled line. Lead finish/Ball material values may wrap to two lines if the finish value exceeds the maximum column width.

Important Information and Disclaimer:The information provided on this page represents TI's knowledge and belief as of the date that it is provided. TI bases its knowledge and belief on information provided by third parties, and makes no representation or warranty as to the accuracy of such information. Efforts are underway to better integrate information from third parties. TI has taken and continues to take reasonable steps to provide representative and accurate information but may not have conducted destructive testing or chemical analysis on incoming materials and chemicals. TI and TI suppliers consider certain information to be proprietary, and thus CAS numbers and other limited information may not be available for release.

In no event shall TI's liability arising out of such information exceed the total purchase price of the TI part(s) at issue in this document sold by TI to Customer on an annual basis.

TAPE AND REEL INFORMATION

QUADRANT ASSIGNMENTS FOR PIN 1 ORIENTATION IN TAPE



*All dimensions are nominal

Device	Package Type	Package Drawing	Pins	SPQ	Reel Diameter (mm)	Reel Width W1 (mm)	A0 (mm)	B0 (mm)	K0 (mm)	P1 (mm)	W (mm)	Pin1 Quadrant
OPA2369AIDCNR	SOT-23	DCN	8	3000	179.0	8.4	3.2	3.2	1.4	4.0	8.0	Q3
OPA2369AIDCNT	SOT-23	DCN	8	250	179.0	8.4	3.2	3.2	1.4	4.0	8.0	Q3
OPA369AIDCKR	SC70	DCK	5	3000	178.0	9.0	2.4	2.5	1.2	4.0	8.0	Q3
OPA369AIDCKR	SC70	DCK	5	3000	179.0	8.4	2.2	2.5	1.2	4.0	8.0	Q3
OPA369AIDCKT	SC70	DCK	5	250	178.0	9.0	2.4	2.5	1.2	4.0	8.0	Q3
OPA369AIDCKT	SC70	DCK	5	250	179.0	8.4	2.2	2.5	1.2	4.0	8.0	Q3

TAPE AND REEL BOX DIMENSIONS

*All dimensions are nominal

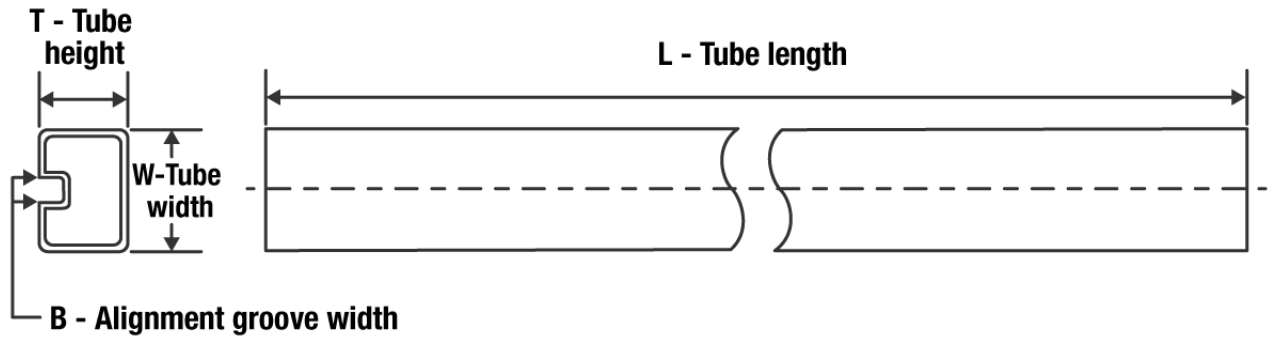
Device	Package Type	Package Drawing	Pins	SPQ	Length (mm)	Width (mm)	Height (mm)
OPA2369AIDCNR	SOT-23	DCN	8	3000	213.0	191.0	35.0
OPA2369AIDCNT	SOT-23	DCN	8	250	213.0	191.0	35.0
OPA369AIDCKR	SC70	DCK	5	3000	180.0	180.0	18.0
OPA369AIDCKR	SC70	DCK	5	3000	213.0	191.0	35.0
OPA369AIDCKT	SC70	DCK	5	250	180.0	180.0	18.0
OPA369AIDCKT	SC70	DCK	5	250	213.0	191.0	35.0

TUBE

*All dimensions are nominal

Device	Package Name	Package Type	Pins	SPQ	L (mm)	W (mm)	T (μm)	B (mm)
OPA2369AIDGKR	DGK	VSSOP	8	2500	274	6.55	500	2.88
OPA2369AIDGKT	DGK	VSSOP	8	250	274	6.55	500	2.88
OPA2369AIDGKTG4	DGK	VSSOP	8	250	274	6.55	500	2.88

DCN (R-PDSO-G8)

PLASTIC SMALL-OUTLINE PACKAGE (DIE DOWN)

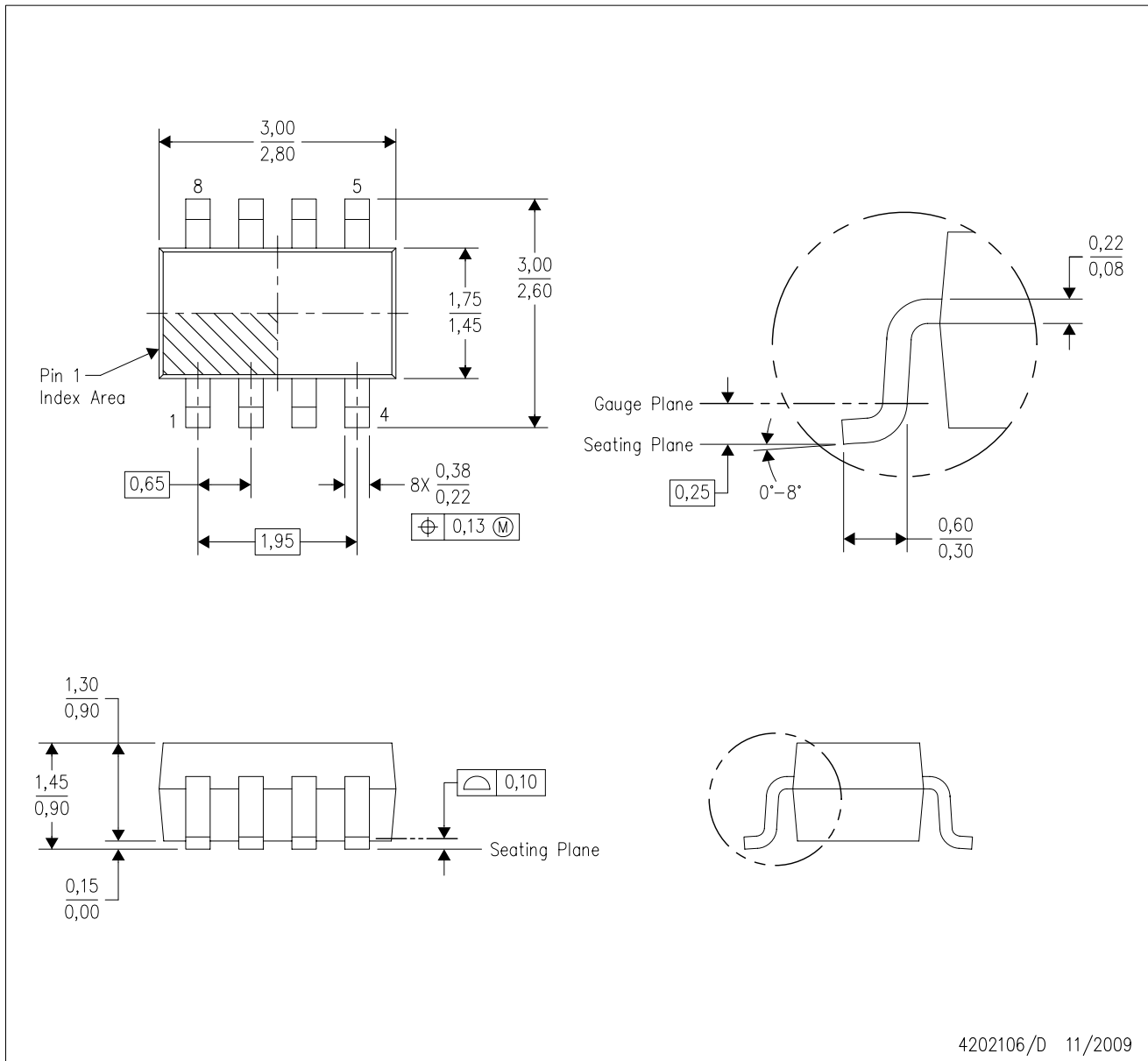

- NOTES:
- A. All linear dimensions are in millimeters.
 - B. This drawing is subject to change without notice.
 - C. Package outline exclusive of metal burr & dambar protrusion/intrusion.
 - D. Package outline inclusive of solder plating.
 - E. A visual index feature must be located within the Pin 1 index area.
 - F. Falls within JEDEC MO-178 Variation BA.
 - G. Body dimensions do not include flash or protrusion. Mold flash and protrusion shall not exceed 0.25 per side.

DCN (R-PDSO-G8)

PLASTIC SMALL-OUTLINE PACKAGE (DIE DOWN)

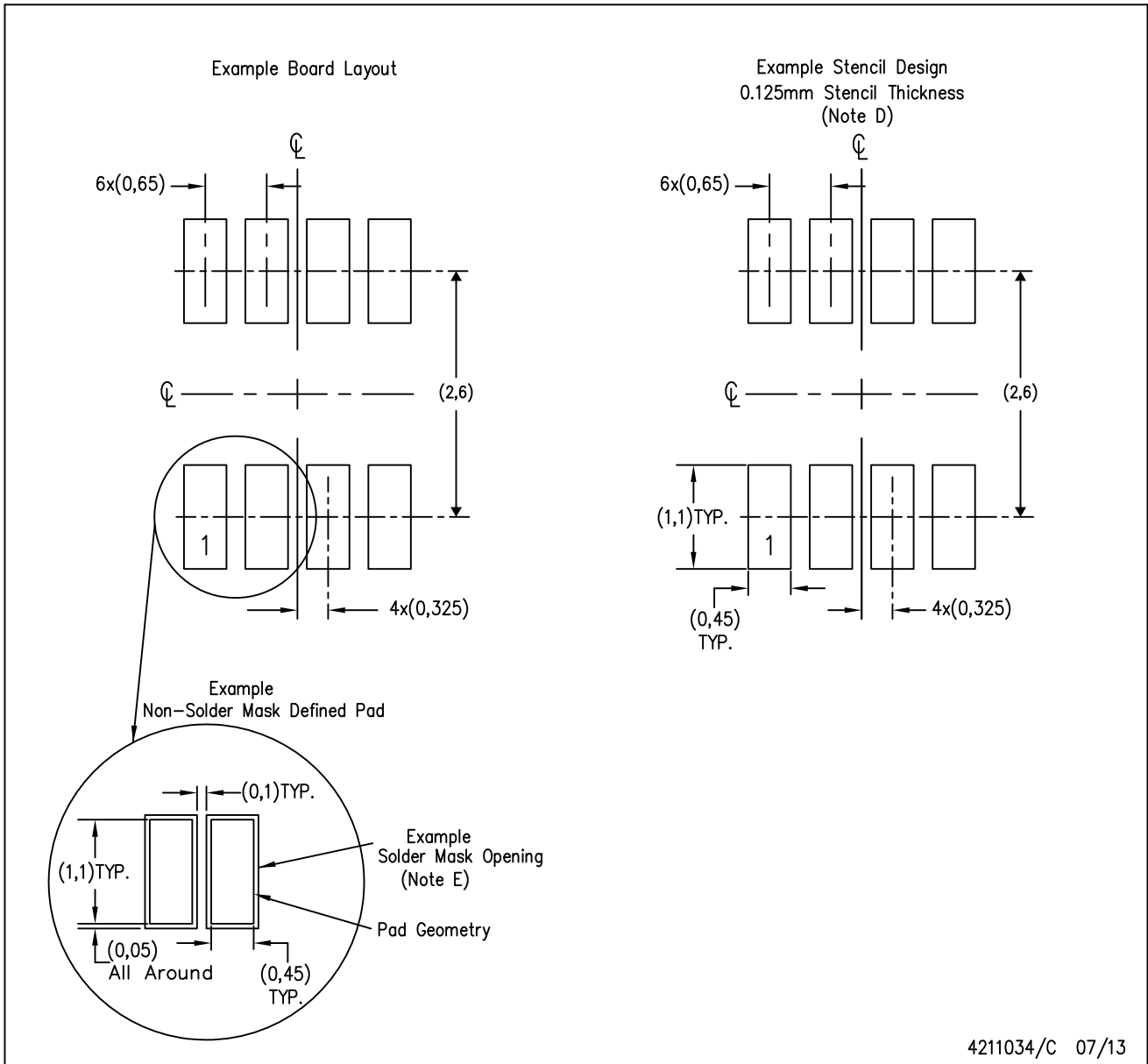

- NOTES:
- A. All linear dimensions are in millimeters.
 - B. This drawing is subject to change without notice.
 - C. Publication IPC-7351 is recommended for alternate designs.
 - D. Laser cutting apertures with trapezoidal walls and also rounding corners will offer better paste release. Customers should contact their board assembly site for stencil design recommendations. Refer to IPC-7525.
 - E. Customers should contact their board fabrication site for solder mask tolerances between and around signal pads.

DGK (S-PDSO-G8)

PLASTIC SMALL-OUTLINE PACKAGE



- NOTES:
- A. All linear dimensions are in millimeters.
 - B. This drawing is subject to change without notice.
 - C. Body length does not include mold flash, protrusions, or gate burrs. Mold flash, protrusions, or gate burrs shall not exceed 0.15 per end.
 - D. Body width does not include interlead flash. Interlead flash shall not exceed 0.50 per side.
 - E. Falls within JEDEC MO-187 variation AA, except interlead flash.



- NOTES:
- A. All linear dimensions are in millimeters.
 - B. This drawing is subject to change without notice.
 - C. Publication IPC-7351 is recommended for alternate designs.
 - D. Laser cutting apertures with trapezoidal walls and also rounding corners will offer better paste release. Customers should contact their board assembly site for stencil design recommendations. Refer to IPC-7525 for other stencil recommendations.
 - E. Customers should contact their board fabrication site for solder mask tolerances between and around signal pads.

DCK (R-PDSO-G5)

PLASTIC SMALL OUTLINE



- NOTES:
- A. All linear dimensions are in millimeters.
 - B. This drawing is subject to change without notice.
 - C. Customers should place a note on the circuit board fabrication drawing not to alter the center solder mask defined pad.
 - D. Publication IPC-7351 is recommended for alternate designs.
 - E. Laser cutting apertures with trapezoidal walls and also rounding corners will offer better paste release. Customers should contact their board assembly site for stencil design recommendations. Example stencil design based on a 50% volumetric metal load solder paste. Refer to IPC-7525 for other stencil recommendations.

IMPORTANT NOTICE AND DISCLAIMER

TI PROVIDES TECHNICAL AND RELIABILITY DATA (INCLUDING DATA SHEETS), DESIGN RESOURCES (INCLUDING REFERENCE DESIGNS), APPLICATION OR OTHER DESIGN ADVICE, WEB TOOLS, SAFETY INFORMATION, AND OTHER RESOURCES "AS IS" AND WITH ALL FAULTS, AND DISCLAIMS ALL WARRANTIES, EXPRESS AND IMPLIED, INCLUDING WITHOUT LIMITATION ANY IMPLIED WARRANTIES OF MERCHANTABILITY, FITNESS FOR A PARTICULAR PURPOSE OR NON-INFRINGEMENT OF THIRD PARTY INTELLECTUAL PROPERTY RIGHTS.

These resources are intended for skilled developers designing with TI products. You are solely responsible for (1) selecting the appropriate TI products for your application, (2) designing, validating and testing your application, and (3) ensuring your application meets applicable standards, and any other safety, security, regulatory or other requirements.

These resources are subject to change without notice. TI grants you permission to use these resources only for development of an application that uses the TI products described in the resource. Other reproduction and display of these resources is prohibited. No license is granted to any other TI intellectual property right or to any third party intellectual property right. TI disclaims responsibility for, and you will fully indemnify TI and its representatives against, any claims, damages, costs, losses, and liabilities arising out of your use of these resources.

TI's products are provided subject to [TI's Terms of Sale](#) or other applicable terms available either on [ti.com](https://www.ti.com) or provided in conjunction with such TI products. TI's provision of these resources does not expand or otherwise alter TI's applicable warranties or warranty disclaimers for TI products.

TI objects to and rejects any additional or different terms you may have proposed.

Mailing Address: Texas Instruments, Post Office Box 655303, Dallas, Texas 75265
Copyright © 2023, Texas Instruments Incorporated

X-ON Electronics

Largest Supplier of Electrical and Electronic Components

Click to view similar products for [Operational Amplifiers - Op Amps](#) category:

Click to view products by [Texas Instruments](#) manufacturer:

Other Similar products are found below :

[430227FB](#) [LT1678IS8](#) [NCV33202DMR2G](#) [NJM324E](#) [M38510/13101BPA](#) [NTE925](#) [AZV358MTR-G1](#) [AP4310AUMTR-AG1](#)
[AZV358MMTR-G1](#) [SCY33178DR2G](#) [NCV20034DR2G](#) [NTE778S](#) [NTE871](#) [NTE937](#) [NJU7057RB1-TE2](#) [SCY6358ADR2G](#)
[NJM2904CRB1-TE1](#) [UPC4570G2-E1-A](#) [UPC4741G2-E1-A](#) [NJM8532RB1-TE1](#) [EL2250CS](#) [EL5100IS](#) [EL5104IS](#) [EL5127CY](#) [EL5127CZY](#)
[EL5133IW](#) [EL5152IS](#) [EL5156IS](#) [EL5162IS](#) [EL5202IY](#) [EL5203IY](#) [EL5204IY](#) [EL5210CS](#) [EL5210CZY](#) [EL5211IYE](#) [EL5220CY](#)
[EL5223CLZ](#) [EL5223CR](#) [EL5224ILZ](#) [EL5227CLZ](#) [EL5227CRZ](#) [EL5244CS](#) [EL5246CS](#) [EL5246CSZ](#) [EL5250IY](#) [EL5251IS](#) [EL5257IS](#)
[EL5260IY](#) [EL5261IS](#) [EL5300IU](#)