

## 50-MHz 低失真 高-CMRR 轨到轨 I/O, 单电源操作放大器

 查询样品: [OPA365-EP](#)

### 特性

- 增益带宽: **50MHz**
- 零交叉失真拓扑
  - 出色的 **THD+N: 0.0004%**
  - **CMRR: 96.5 dB** (最小值)
  - 轨至轨输入/输出
  - 输入超出供电轨范围 **100 mV**
- 低噪声: **4.5nV/√Hz** (在 **100kHz** 频率条件下)
- 转换率: **25 V/μs**
- 快速稳定: **0.3 μs** 到 **0.01%**
- 精度
  - 低补偿: **100 μV**  
(在 **25°C**时的典型值)
  - 低输入偏压电流: **0.2 pA**  
(在 **25°C**时的典型值)
- **2.5V** 至 **5.5V** 操作

### 支持国防、航天和医疗应用

- 受控基线
- 一个组装/测试场所
- 一个制造场所
- 在军用温度范围内 (**-55°C/175°C**)工作<sup>(1)</sup>
- 拓展的产品使用寿命
- 拓展的产品改变通知
- 产品可追溯性

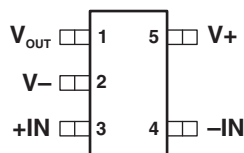
**DBV PACKAGE  
(TOP VIEW)**

(1) 可提供额外温度范围 - 请与厂家联系

### 说明

OPA365 零交叉系列产品, 轨到轨, 高性能, CMOS 运行放大器, 优化后用于极低电压, 单电源应用。轨到轨输入/输出, 低噪音 ( $4.5 \text{ nV}/\sqrt{\text{Hz}}$ ) 和高速操作 ( $50\text{-MHz}$  增益带宽) 是这款设备非常适合驱动取样模数转换器 (ADC)。OPA365 支持音频、信号调节、传感器放大、国防、航空航天和医疗应用。OPA365 还非常适合手机功率放大器控制环路的应用。

特性包括出色的共模抑制比 (CMRR), 无输入阶段交叉失真, 高输出阻抗和轨到轨输入和输出摆动。输入共模范围包括负电源和正电源。输出电压摆幅在电轨的 $10\text{mV}$ 之内。

OPA365 采用 SOT23-5 封装方式并具有  $-55^\circ\text{C}$  至  $125^\circ\text{C}$  的工作温度范围。



图 1. 快速稳定峰值探测器



Please be aware that an important notice concerning availability, standard warranty, and use in critical applications of Texas Instruments semiconductor products and disclaimers thereto appears at the end of this data sheet.

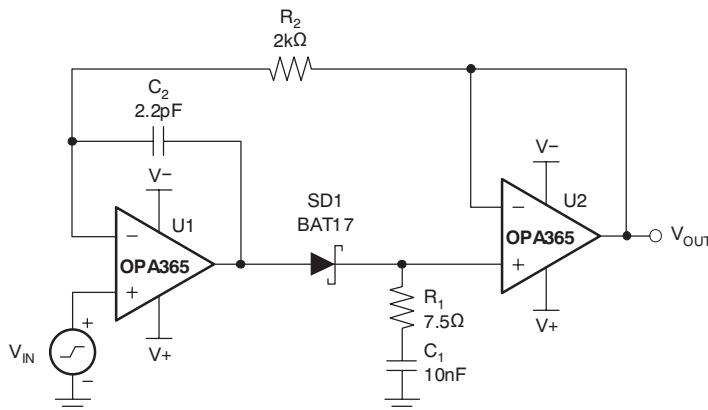

This integrated circuit can be damaged by ESD. Texas Instruments recommends that all integrated circuits be handled with appropriate precautions. Failure to observe proper handling and installation procedures can cause damage.

ESD damage can range from subtle performance degradation to complete device failure. Precision integrated circuits may be more susceptible to damage because very small parametric changes could cause the device not to meet its published specifications.

### ORDERING INFORMATION<sup>(1)</sup>

T <sub>A</sub>	PACKAGE	ORDERABLE PART NUMBER	TOP-SIDE MARKING
-55°C to 125°C	SOT23 – DBV	OPA365AMDBVTEP	OUNM

- (1) For the most current package and ordering information, see the Package Option Addendum at the end of this document, or see the TI web site at [www.ti.com](http://www.ti.com).

### ABSOLUTE MAXIMUM RATINGS<sup>(1)</sup>

V <sub>CC</sub>	Supply voltage		5.5 V
V <sub>I</sub>	Signal input terminals, voltage <sup>(2)</sup>		(V <sub>-</sub> ) - 0.5V to (V <sub>+</sub> ) + 0.5 V
I <sub>I</sub>	Signal input terminals, current <sup>(2)</sup>		±10 mA
t <sub>OSC</sub>	Output short-circuit duration <sup>(3)(4)</sup>		Continuous
T <sub>OP</sub>	Operating temperature		-55°C to 125°C
T <sub>stg</sub>	Storage temperature		-65°C to 150°C
T <sub>J</sub>	Junction temperature		150°C
ESD	Electrostatic discharge rating	Human Body Model	4000V
		Charged Device Model	1000V
		Machine Model	200V

- (1) Stresses beyond those listed under *absolute maximum ratings* may cause permanent damage to the device. These are stress ratings only, and functional operation of the device at these or any other conditions beyond those indicated under *recommended operating conditions* is not implied. Exposure to absolute-maximum-rated conditions for extended periods may affect device reliability.
- (2) Input terminals are diode-clamped to the power-supply rails. Input signals that can swing more than 0.5V beyond the supply rails should be current limited to 10mA or less.
- (3) Short-circuit to ground, one amplifier per package
- (4) Continuous output current greater than 20 mA for extended periods may affect product reliability.

**ELECTRICAL CHARACTERISTICS**
 $V_S = 2.2\text{ V to }5.5\text{ V}$ ,  $R_L = 10\text{ k}\Omega$  connected to  $V_S/2$ ,  $V_{CM} = V_S/2$ , and  $V_{OUT} = V_S/2$  (unless otherwise noted)

PARAMETER		TEST CONDITIONS	$T_A^{(1)}$	MIN	TYP	MAX	UNIT
<b>OFFSET VOLTAGE</b>							
$V_{OS}$	Input offset voltage		25°C	100	200		$\mu\text{V}$
			Full range		450		
$dV_{OS}/dT$	Input offset voltage drift		Full range	3			$\mu\text{V}/^\circ\text{C}$
PSRR	Input offset voltage vs power supply	$V_S = +2.2\text{V to }+5.5\text{V}$	Full range	10	100		$\mu\text{V}/\text{V}$
<b>INPUT BIAS CURRENT</b>							
$I_B$	Input bias current		25°C	$\pm 0.2$	$\pm 10$		$\text{pA}$
			Full range	See Typical Characteristics			
$I_{OS}$	Input offset current		25°C	$\pm 0.2$	$\pm 10$		$\text{pA}$
<b>NOISE</b>							
$e_n$	Input voltage noise	$f = 0.1\text{Hz to }10\text{Hz}$	25°C	5			$\mu\text{V}_{PP}$
$e_n$	Input voltage noise density	$f = 100\text{kHz}$	25°C	4.5			$\text{nV}/\sqrt{\text{Hz}}$
$i_n$	Input current noise density	$f = 10\text{kHz}$	25°C	4			$\text{fA}/\sqrt{\text{Hz}}$
<b>INPUT VOLTAGE RANGE</b>							
$V_{CM}$	Common-mode voltage range		Full range	$(V_-) - 0.1$	$(V_+) + 0.1$		$\text{V}$
CMRR	Common-mode rejection ratio	$(V_-) - 0.1\text{V} \leq V_{CM} \leq (V_+) + 0.1\text{V}$	Full range	96.5	120		$\text{dB}$
<b>INPUT CAPACITANCE</b>							
	Differential		25°C	6			$\text{pF}$
	Common-mode		25°C	2			$\text{pF}$
<b>OPEN-LOOP GAIN</b>							
$A_{OL}$	Open-loop voltage gain	$R_L = 10\text{k}\Omega$ , $100\text{mV} < V_O < (V_+) - 100\text{mV}$	Full range	96.5	120		$\text{dB}$
		$R_L = 600\Omega$ , $200\text{mV} < V_O < (V_+) - 200\text{mV}$	25°C	100	120		
		$R_L = 600\Omega$ , $200\text{mV} < V_O < (V_+) - 200\text{mV}$	Full range	91			
<b>FREQUENCY RESPONSE</b>							
GBW	Gain-bandwidth product		25°C	50			$\text{MHz}$
SR	Slew rate	$V_S = 5\text{V}$ , $G = +1$	25°C	25			$\text{V}/\mu\text{s}$
$t_S$	Settling time	0.1%, $V_S = 5\text{V}$ , 4V Step, $G = +1$	25°C	200			$\text{ns}$
		0.01%, $V_S = 5\text{V}$ , 4V Step, $G = +1$	25°C	300			
	Overload recovery time	$V_S = 5\text{V}$ , $V_{IN} \times \text{Gain} > V_S$	25°C	< 0.1			$\mu\text{s}$
THD+N	Total harmonic distortion + noise <sup>(2)</sup>	$V_S = 5\text{V}$ , $R_L = 600\Omega$ , $V_O = 4\text{V}_{PP}$ , $G = +1$ , $f = 1\text{kHz}$	25°C	0.0004			$\%$
<b>OUTPUT</b>							
	Voltage output swing from rail	$R_L = 10\text{k}\Omega$ , $V_S = 5.5\text{V}$	Full range	10	20		$\text{mV}$
$I_{SC}$	Short-circuit current <sup>(3)</sup>		25°C	$\pm 65$			$\text{mA}$
$C_L$	Capacitive load drive		25°C	See Typical Characteristics			
	Open-loop output impedance	$f = 1\text{MHz}$ , $I_O = 0$	25°C	30			$\Omega$
<b>POWER SUPPLY</b>							
$V_S$	Specified voltage range		Full range	2.2	5.5		$\text{V}$
$I_Q$	Quiescent current per amplifier	$I_O = 0$	25°C	4.6	5		$\text{mA}$
			Full range		5.5		

(1) Full range  $T_A = -55^\circ\text{C to }+125^\circ\text{C}$ 

(2) Third-order filter, bandwidth 80kHz at -3dB.

(3) Continuous output current greater than 20 mA for extended periods may affect product reliability.

**ELECTRICAL CHARACTERISTICS (continued)**

$V_S = 2.2\text{ V to } 5.5\text{ V}$ ,  $R_L = 10\text{ k}\Omega$  connected to  $V_S/2$ ,  $V_{CM} = V_S/2$ , and  $V_{OUT} = V_S/2$  (unless otherwise noted)

PARAMETER	TEST CONDITIONS	$T_A^{(1)}$	MIN	TYP	MAX	UNIT
<b>TEMPERATURE RANGE</b>						
	Specified range		-55		125	°C
$\theta_{JA}$	Thermal resistance			200		°C/W

**TYPICAL CHARACTERISTICS**

$T_A = 25^\circ\text{C}$ ,  $V_S = 5\text{ V}$ ,  $C_L = 0\text{ pF}$  (unless otherwise noted)

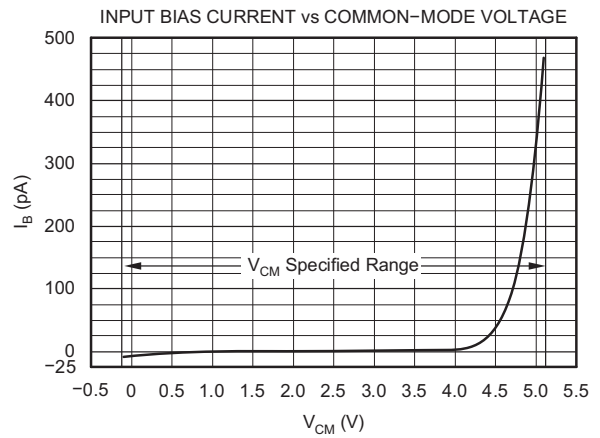
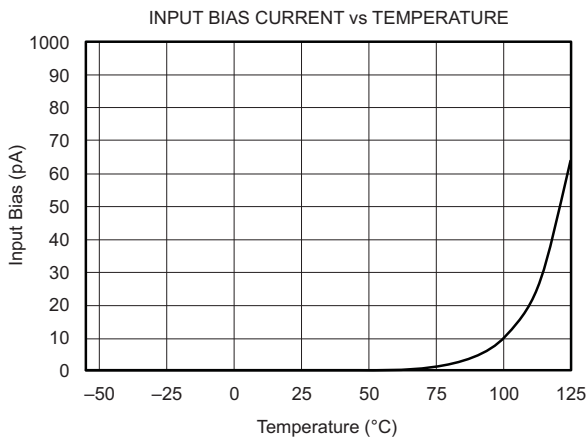
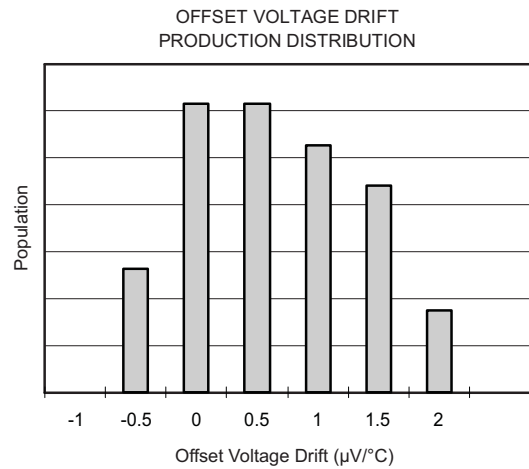
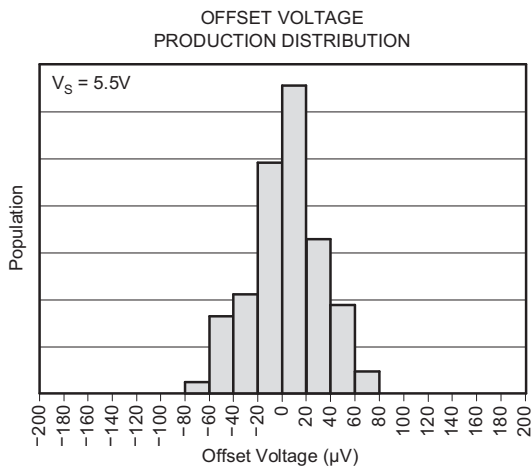
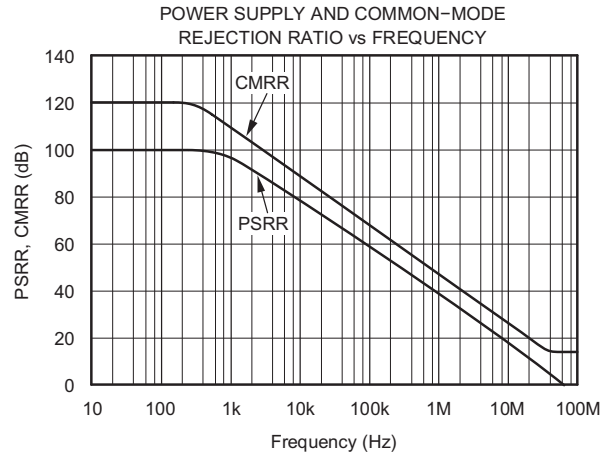
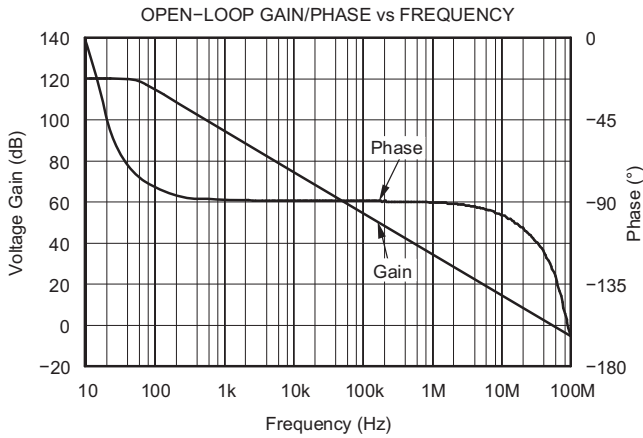

**TYPICAL CHARACTERISTICS (continued)**

$T_A = 25^\circ\text{C}$ ,  $V_S = 5\text{ V}$ ,  $C_L = 0\text{ pF}$  (unless otherwise noted)

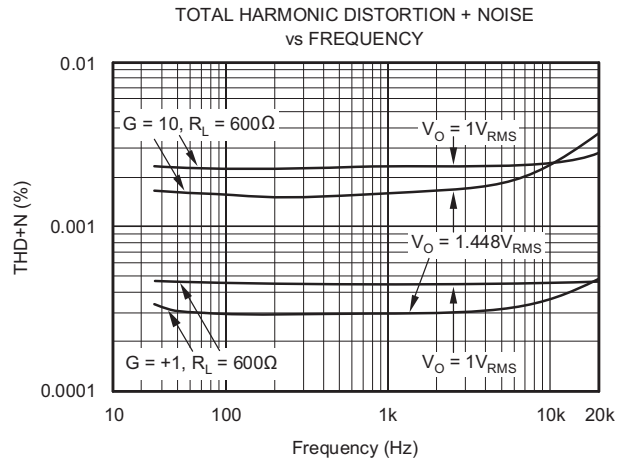
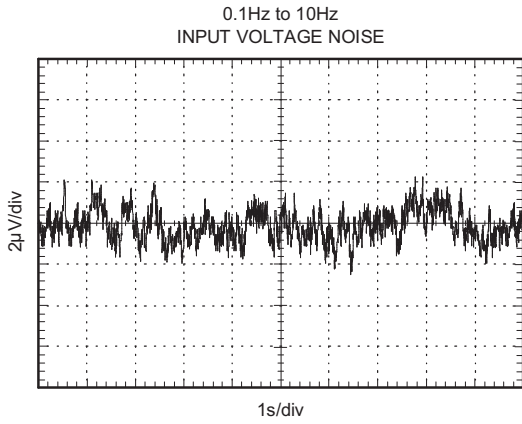
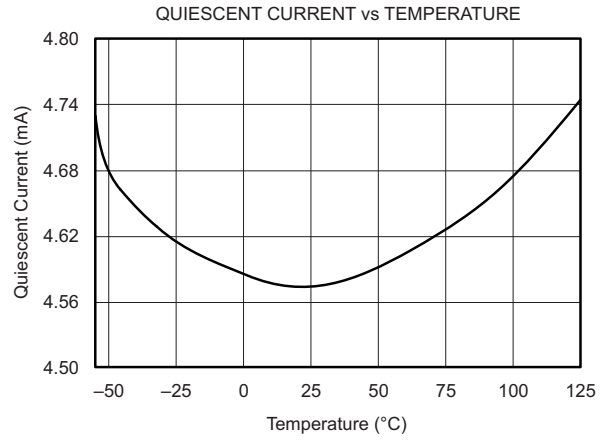
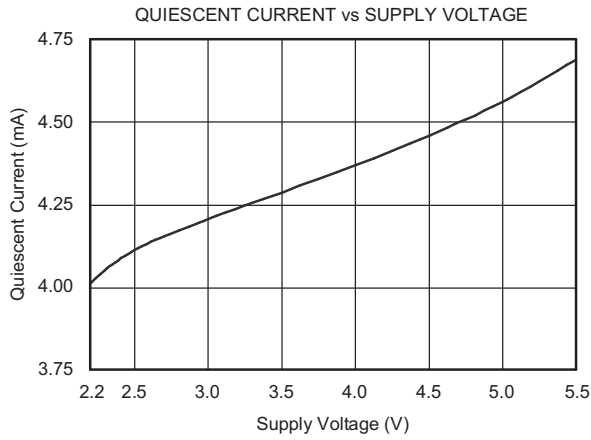
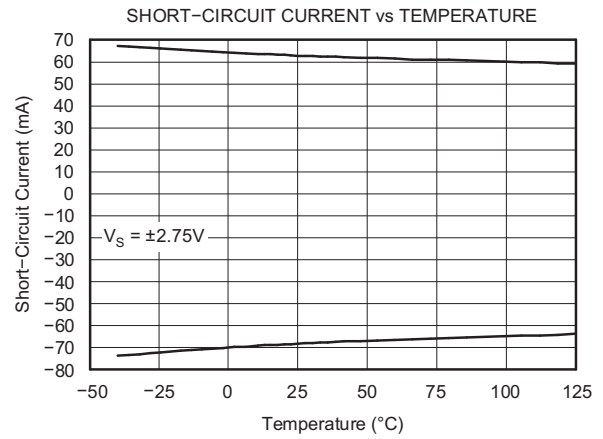
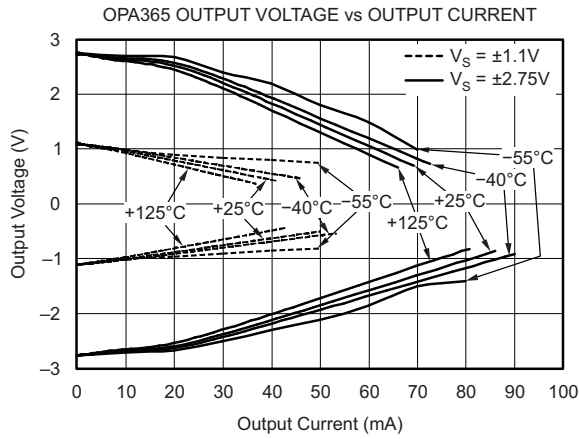

**TYPICAL CHARACTERISTICS (continued)**

$T_A = 25^\circ\text{C}$ ,  $V_S = 5\text{ V}$ ,  $C_L = 0\text{ pF}$  (unless otherwise noted)

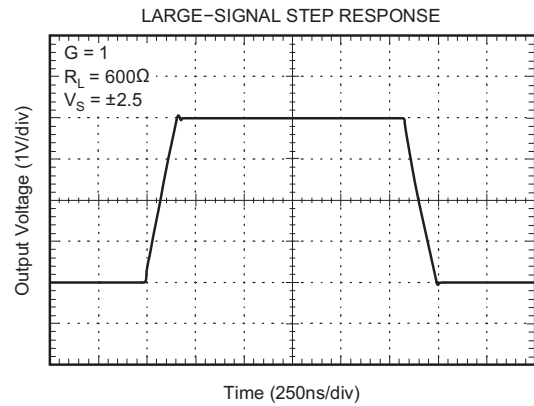
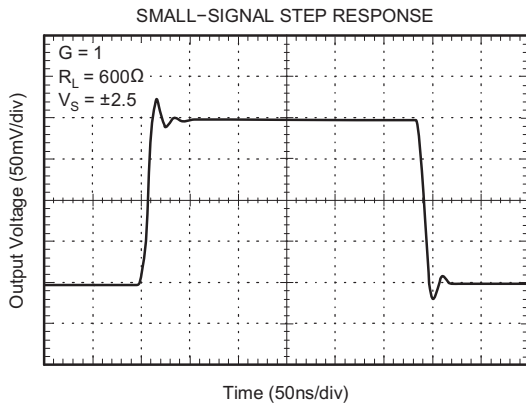
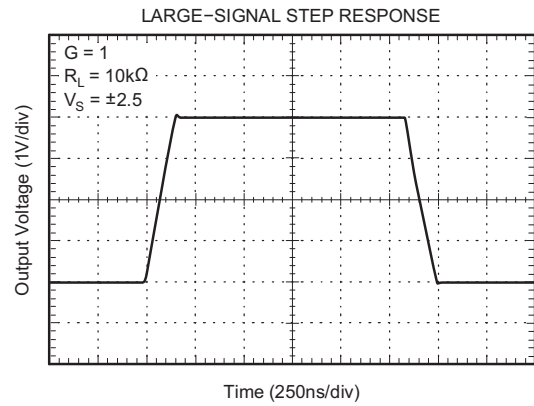
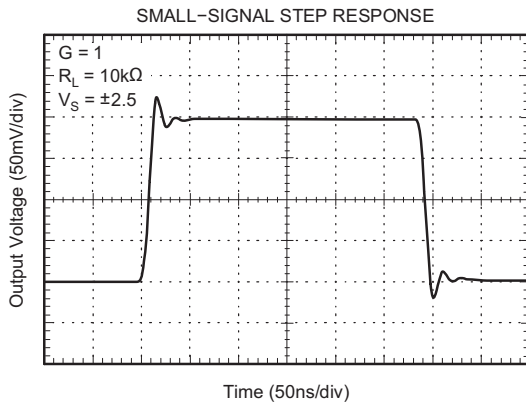
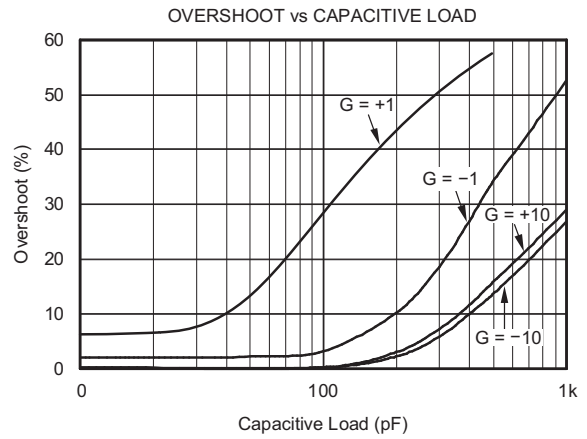
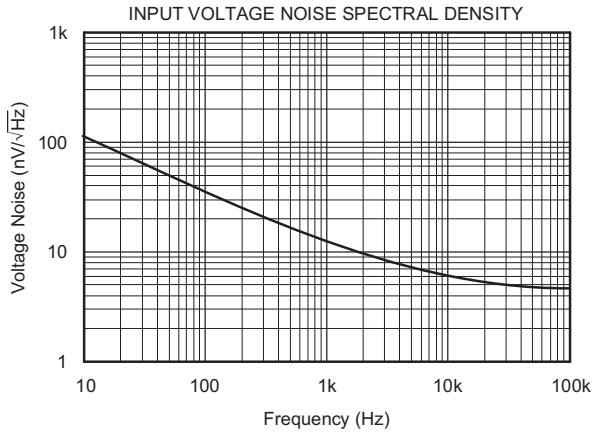

## APPLICATION INFORMATION

### Operating Characteristics

The OPA365 amplifier parameters are fully specified from 2.2 V to 5.5 V. Many of the specifications apply from  $-55^{\circ}\text{C}$  to  $125^{\circ}\text{C}$ . Parameters that can exhibit significant variance with regard to operating voltage or temperature are presented in *Typical Characteristics*.

### General Layout Guidelines

The OPA365 is a wideband amplifier. To realize the full operational performance of the device, good high-frequency printed circuit board (PCB) layout practices are required. Low-loss 0.1- $\mu\text{F}$  bypass capacitors must be connected between each supply pin and ground as close to the device as possible. The bypass capacitor traces should be designed for minimum inductance.

### Basic Amplifier Configurations

As with other single-supply op amps, the OPA365 may be operated with either a single supply or dual supplies (see Figure 2). A typical dual-supply connection is shown in Figure 2, which is accompanied by a single-supply connection. The OPA365 is configured as a basic inverting amplifier with a gain of  $-10 \text{ V/V}$ . The dual-supply connection has an output voltage centered on zero, while the single-supply connection has an output centered on the common-mode voltage  $V_{\text{CM}}$ . For the circuit shown, this voltage is 1.5 V, but may be any value within the common-mode input voltage range. The OPA365  $V_{\text{CM}}$  range extends 100 mV beyond the power-supply rails.

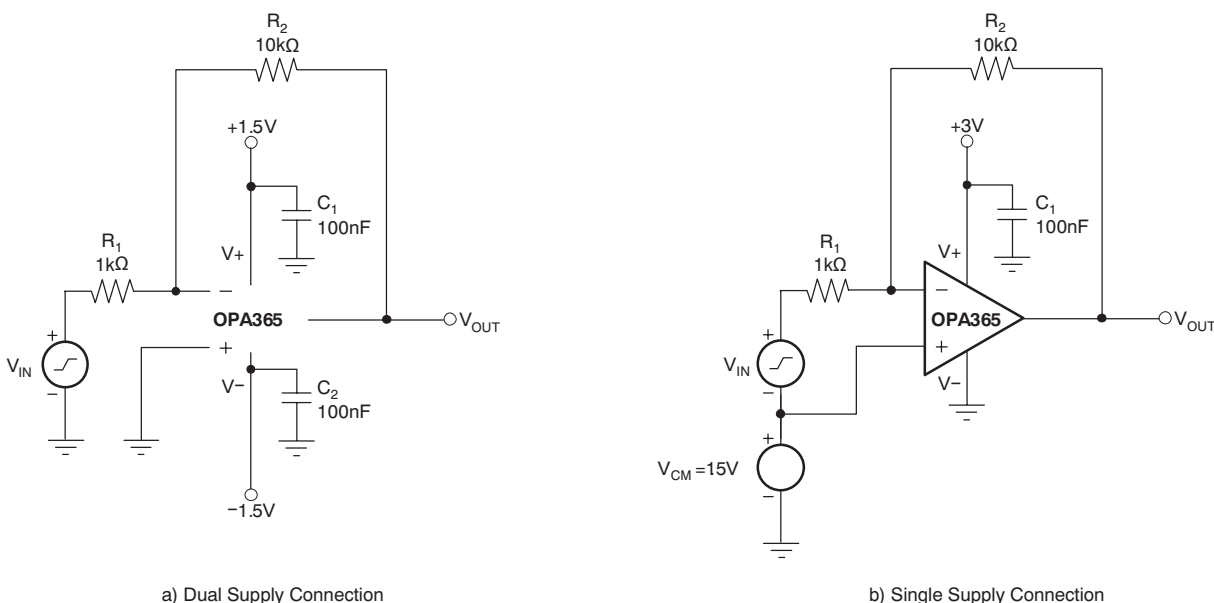

**Figure 2. Basic Circuit Connections**



Figure 3 shows a single-supply, electret microphone application where  $V_{CM}$  is provided by a resistive divider. The divider also provides the bias voltage for the electret element.

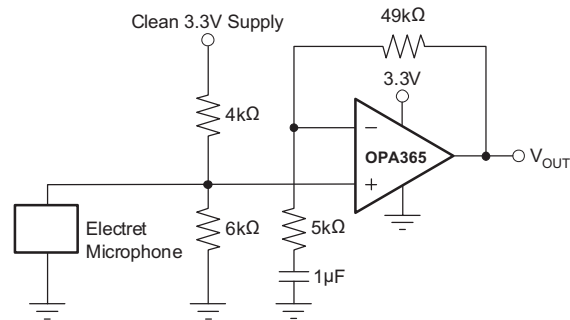

Figure 3. Microphone Preamplifier

### Input and ESD Protection

The OPA365 incorporates internal electrostatic discharge (ESD) protection circuits on all pins. In the case of input and output pins, this protection primarily consists of current steering diodes connected between the input and power-supply pins. These ESD protection diodes also provide in-circuit, input overdrive protection, provided that the current is limited to 10 mA as stated in the Absolute Maximum Ratings. Figure 4 shows how a series input resistor may be added to the driven input to limit the input current. The added resistor contributes thermal noise at the amplifier input and its value should be kept to the minimum in noise-sensitive applications.

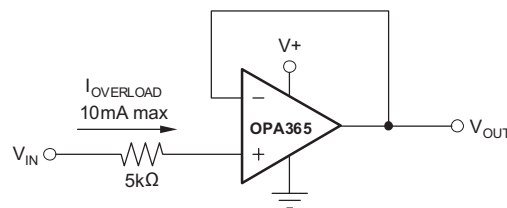

Figure 4. Input Current Protection

### Rail-to-Rail Input

The OPA365 features true rail-to-rail input operation, with supply voltages as low as  $\pm 1.1$  V (2.2 V). A unique zero-crossover input topology eliminates the input offset transition region typical of many rail-to-rail, complementary stage operational amplifiers. This topology also allows the OPA365 to provide superior common-mode performance over the entire input range, which extends 100 mV beyond both power-supply rails, as shown in Figure 5. When driving ADCs, the highly linear VCM range of the OPA365 assures that the op amp/ADC system linearity performance is not compromised.

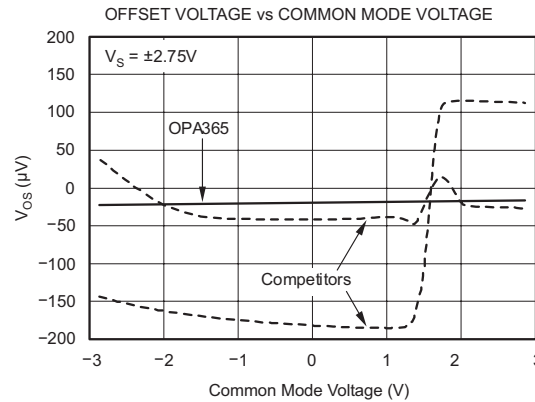

Figure 5. OPA365 has Linear Offset Over the Entire Common-Mode Range

A simplified schematic illustrating the rail-to-rail input circuitry is shown in Figure 6.

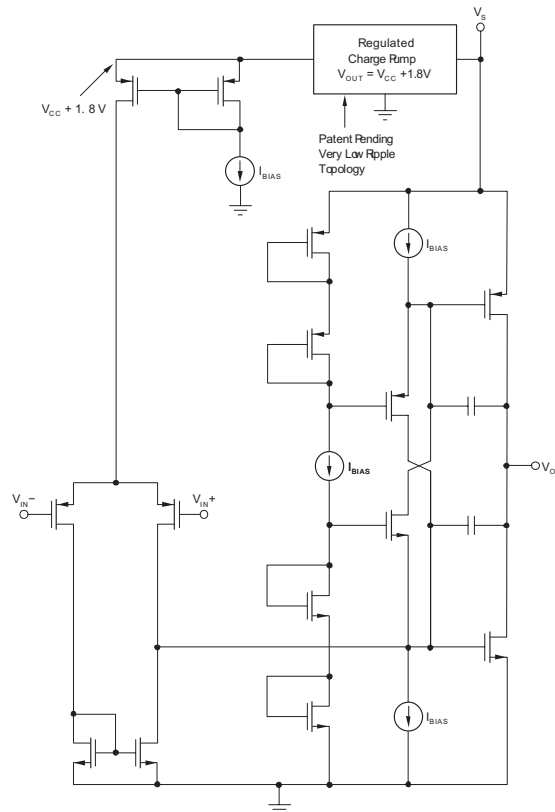

Figure 6. Simplified Schematic

## Capacitive Loads

The OPA365 may be used in applications where driving a capacitive load is required. As with all op amps, there may be specific instances where the OPA365 can become unstable, leading to oscillation. The particular op amp circuit configuration, layout, gain and output loading are some of the factors to consider when establishing whether an amplifier will be stable in operation. An op amp in the unity-gain (1 V/V) buffer configuration and driving a capacitive load exhibits a greater tendency to be unstable than an amplifier operated at a higher noise gain. The capacitive load, in conjunction with the op amp output resistance, creates a pole within the feedback loop that degrades the phase margin. The degradation of the phase margin increases as the capacitive loading increases.

When operating in the unity-gain configuration, the OPA365 remains stable with a pure capacitive load up to approximately 1 nF. The equivalent series resistance (ESR) of some very large capacitors ( $C_L > 1 \mu\text{F}$ ) is sufficient to alter the phase characteristics in the feedback loop such that the amplifier remains stable. Increasing the amplifier closed-loop gain allows the amplifier to drive increasingly larger capacitance. This increased capability is evident when observing the overshoot response of the amplifier at higher voltage gains. See the typical characteristic graph, Small-Signal Overshoot vs. Capacitive Load.

One technique for increasing the capacitive load drive capability of the amplifier operating in unity gain is to insert a small resistor, typically  $10 \Omega$  to  $20 \Omega$ , in series with the output; see [Figure 7](#). This resistor significantly reduces the overshoot and ringing associated with large capacitive loads. A possible problem with this technique is that a voltage divider is created with the added series resistor and any resistor connected in parallel with the capacitive load. The voltage divider introduces a gain error at the output that reduces the output swing. The error contributed by the voltage divider may be insignificant. For instance, with a load resistance,  $R_L = 10 \text{ k}\Omega$ , and  $R_S = 20 \Omega$ , the gain error is only about 0.2%. However, when  $R_L$  is decreased to  $600 \Omega$ , which the OPA365 is able to drive, the error increases to 7.5%.

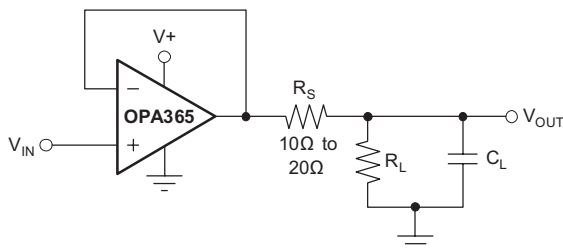
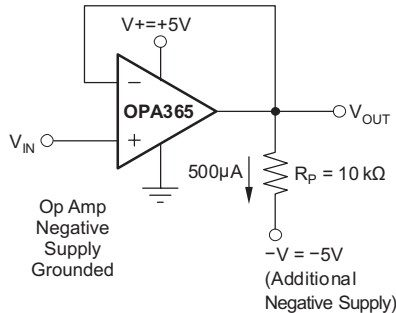

**Figure 7. Improving Capacitive Load Drive**

## Achieving an Output Level of Zero Volts (0V)

Certain single-supply applications require the op amp output to swing from 0 V to a positive full-scale voltage and have high accuracy. An example is an op amp employed to drive a single-supply ADC having an input range from 0 V to 5 V. Rail-to-rail output amplifiers with very light output loading may achieve an output level within millivolts of 0 V (or  $+V_S$  at the high end), but not 0 V. Furthermore, the deviation from 0V only becomes greater as the load current required increases. This increased deviation is a result of limitations of the CMOS output stage.

When a pull-down resistor is connected from the amplifier output to a negative voltage source, the OPA365 can achieve an output level of 0 V, and even a few millivolts below 0 V. Below this limit, nonlinearity and limiting conditions become evident. [Figure 8](#) illustrates a circuit using this technique.



**Figure 8. Swing-to-Ground**

A pull-down current of approximately 500  $\mu\text{A}$  is required when OPA365 is connected as a unity-gain buffer. A practical termination voltage ( $V_{\text{NEG}}$ ) is  $-5\text{ V}$ , but other convenient negative voltages also may be used. The pull-down resistor  $R_L$  is calculated from  $R_L = [(V_O - V_{\text{NEG}})/(500\ \mu\text{A})]$ . Using a minimum output voltage ( $V_O$ ) of 0 V,  $R_L = [0\text{ V} - (-5\text{ V})]/(500\ \mu\text{A}) = 10\text{ k}\Omega$ . Keep in mind that lower termination voltages result in smaller pull-down resistors that load the output during positive output voltage excursions.

Note that this technique does not work with all op amps and should only be applied to op amps such as the OPA365 that have been specifically designed to operate in this manner. Also, operating the OPA365 output at 0 V changes the output stage operating conditions, resulting in somewhat lower open-loop gain and bandwidth. Keep these precautions in mind when driving a capacitive load because these conditions can affect circuit transient response and stability.

## Active Filtering

The OPA365 is well-suited for active filter applications requiring a wide bandwidth, fast slew rate, low-noise, single-supply operational amplifier. Figure 9 shows a 500-kHz, 2nd-order, low-pass filter utilizing the multiple-feedback (MFB) topology. The components have been selected to provide a maximally-flat Butterworth response. Beyond the cutoff frequency, roll-off is  $-40$  dB/dec. The Butterworth response is ideal for applications requiring predictable gain characteristics such as the anti-aliasing filter used ahead of an ADC.

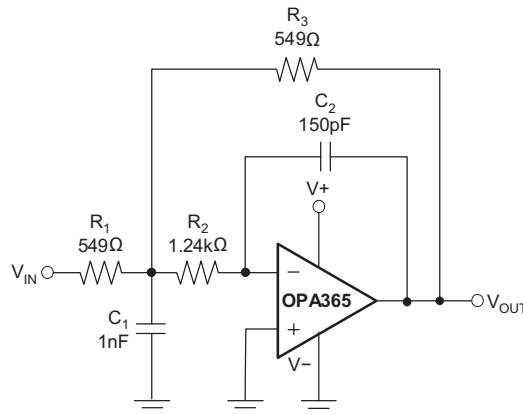

Figure 9. Second-Order Butterworth 500kHz Low-Pass Filter

One point to observe when considering the MFB filter is that the output is inverted, relative to the input. If this inversion is not required, or not desired, a noninverting output can be achieved through one of these options: 1) adding an inverting amplifier; 2) adding an additional 2nd-order MFB stage; or 3) using a noninverting filter topology such as the Sallen-Key (shown in Figure 10). MFB and Sallen-Key, low-pass and high-pass filter synthesis is quickly accomplished using TI's FilterPro program. This software is available as a free download at [www.ti.com](http://www.ti.com).

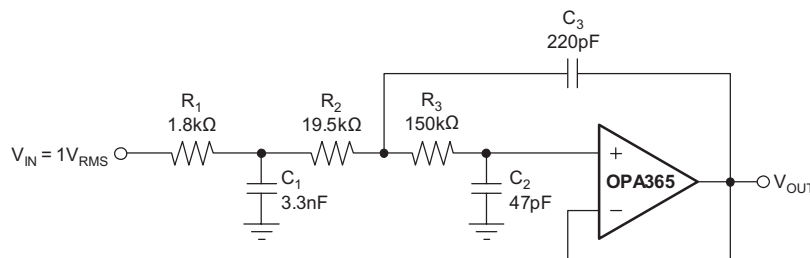

Figure 10. Configured as a 3-Pole, 20kHz, Sallen-Key Filter

## Driving an Analog-to-Digital Converter

Very wide common-mode input range, rail-to-rail input and output voltage capability and high speed make the OPA365 an ideal driver for modern ADCs. Also, because it is free of the input offset transition characteristics inherent to some rail-to-rail CMOS op amps, the OPA365 provides low THD and excellent linearity throughout the input voltage swing range. Figure 11 shows the OPA365 driving an ADS8326, 16-bit, 250kSPS converter. The amplifier is connected as a unity-gain, noninverting buffer and has an output swing to 0 V, making it directly compatible with the ADC minus full-scale input level. The 0-V level is achieved by powering the OPA365 V<sub>-</sub> pin with a small negative voltage established by the diode forward voltage drop. A small, signal-switching diode or Schottky diode provides a suitable negative supply voltage of  $-0.3$  V to  $-0.7$  V. The supply rail-to-rail is equal to V<sub>+</sub>, plus the small negative voltage.

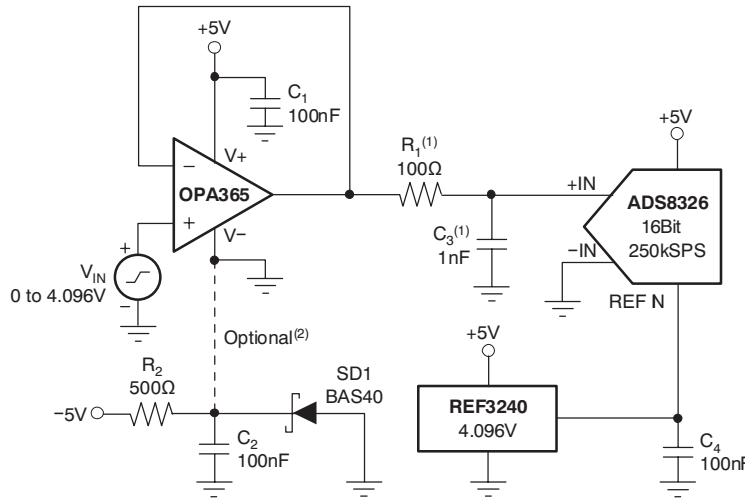

Figure 11. Driving the ADS8326

One method for driving an ADC that negates the need for an output swing down to 0 V uses a slightly compressed ADC full-scale input range (FSR). For example, the 16-bit ADS8361 (shown in Figure 12) has a maximum FSR of 0 V to 5 V, when powered by a 5-V supply and  $V_{REF}$  of 2.5 V. The idea is to match the ADC input range with the op amp full linear output swing range; for example, an output range of 0.1 V to 4.9 V. The reference output from the ADS8361 ADC is divided down from 2.5 V to 2.4 V using a resistive divider. The ADC FSR then becomes  $4.8V_{PP}$  centered on a common-mode voltage of 2.5 V. Current from the ADS8361 reference pin is limited to about  $\pm 10 \mu A$ . Here,  $5 \mu A$  was used to bias the divider. The resistors must be precise to maintain the ADC gain accuracy. An additional benefit of this method is the elimination of the negative supply voltage; it requires no additional power-supply current.

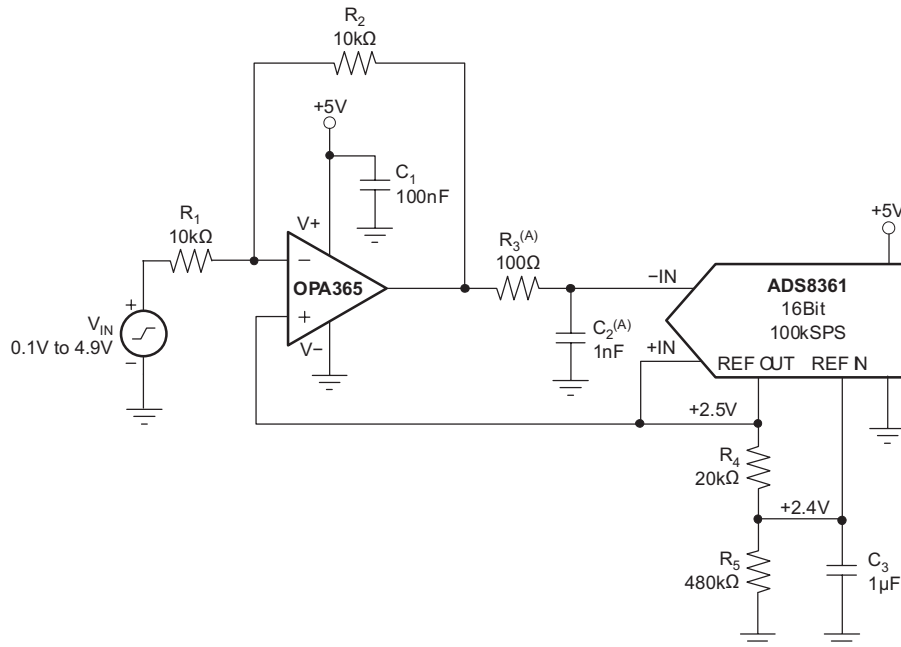

Figure 12. Driving the ADS8361

An RC network, consisting of R1 and C1, is included between the op amp and the ADS8361. It not only provides a high-frequency filter function, but more importantly serves as a charge reservoir used for charging the converter internal hold capacitance. This capability assures that the op amp output linearity is maintained as the ADC input characteristics change throughout the conversion cycle. Depending on the particular application and ADC, some optimization of the R1 and C1 values may be required for best transient performance.

**PACKAGING INFORMATION**

Orderable Device	Status (1)	Package Type	Package Drawing	Pins	Package Qty	Eco Plan (2)	Lead finish/ Ball material (6)	MSL Peak Temp (3)	Op Temp (°C)	Device Marking (4/5)	Samples
OPA365AMDBVTEP	ACTIVE	SOT-23	DBV	5	250	RoHS & Green	NIPDAU	Level-1-260C-UNLIM	-55 to 125	OUNM	<a href="#">Samples</a>
V62/11610-01XE	ACTIVE	SOT-23	DBV	5	250	RoHS & Green	NIPDAU	Level-1-260C-UNLIM	-55 to 125	OUNM	<a href="#">Samples</a>

(1) The marketing status values are defined as follows:

**ACTIVE:** Product device recommended for new designs.

**LIFEBUY:** TI has announced that the device will be discontinued, and a lifetime-buy period is in effect.

**NRND:** Not recommended for new designs. Device is in production to support existing customers, but TI does not recommend using this part in a new design.

**PREVIEW:** Device has been announced but is not in production. Samples may or may not be available.

**OBSOLETE:** TI has discontinued the production of the device.

(2) **RoHS:** TI defines "RoHS" to mean semiconductor products that are compliant with the current EU RoHS requirements for all 10 RoHS substances, including the requirement that RoHS substance do not exceed 0.1% by weight in homogeneous materials. Where designed to be soldered at high temperatures, "RoHS" products are suitable for use in specified lead-free processes. TI may reference these types of products as "Pb-Free".

**RoHS Exempt:** TI defines "RoHS Exempt" to mean products that contain lead but are compliant with EU RoHS pursuant to a specific EU RoHS exemption.

**Green:** TI defines "Green" to mean the content of Chlorine (Cl) and Bromine (Br) based flame retardants meet JS709B low halogen requirements of <=1000ppm threshold. Antimony trioxide based flame retardants must also meet the <=1000ppm threshold requirement.

(3) MSL, Peak Temp. - The Moisture Sensitivity Level rating according to the JEDEC industry standard classifications, and peak solder temperature.

(4) There may be additional marking, which relates to the logo, the lot trace code information, or the environmental category on the device.

(5) Multiple Device Markings will be inside parentheses. Only one Device Marking contained in parentheses and separated by a "~" will appear on a device. If a line is indented then it is a continuation of the previous line and the two combined represent the entire Device Marking for that device.

(6) Lead finish/Ball material - Orderable Devices may have multiple material finish options. Finish options are separated by a vertical ruled line. Lead finish/Ball material values may wrap to two lines if the finish value exceeds the maximum column width.

**Important Information and Disclaimer:**The information provided on this page represents TI's knowledge and belief as of the date that it is provided. TI bases its knowledge and belief on information provided by third parties, and makes no representation or warranty as to the accuracy of such information. Efforts are underway to better integrate information from third parties. TI has taken and continues to take reasonable steps to provide representative and accurate information but may not have conducted destructive testing or chemical analysis on incoming materials and chemicals. TI and TI suppliers consider certain information to be proprietary, and thus CAS numbers and other limited information may not be available for release.

In no event shall TI's liability arising out of such information exceed the total purchase price of the TI part(s) at issue in this document sold by TI to Customer on an annual basis.





# DBV0005A



## PACKAGE OUTLINE

SOT-23 - 1.45 mm max height

SMALL OUTLINE TRANSISTOR

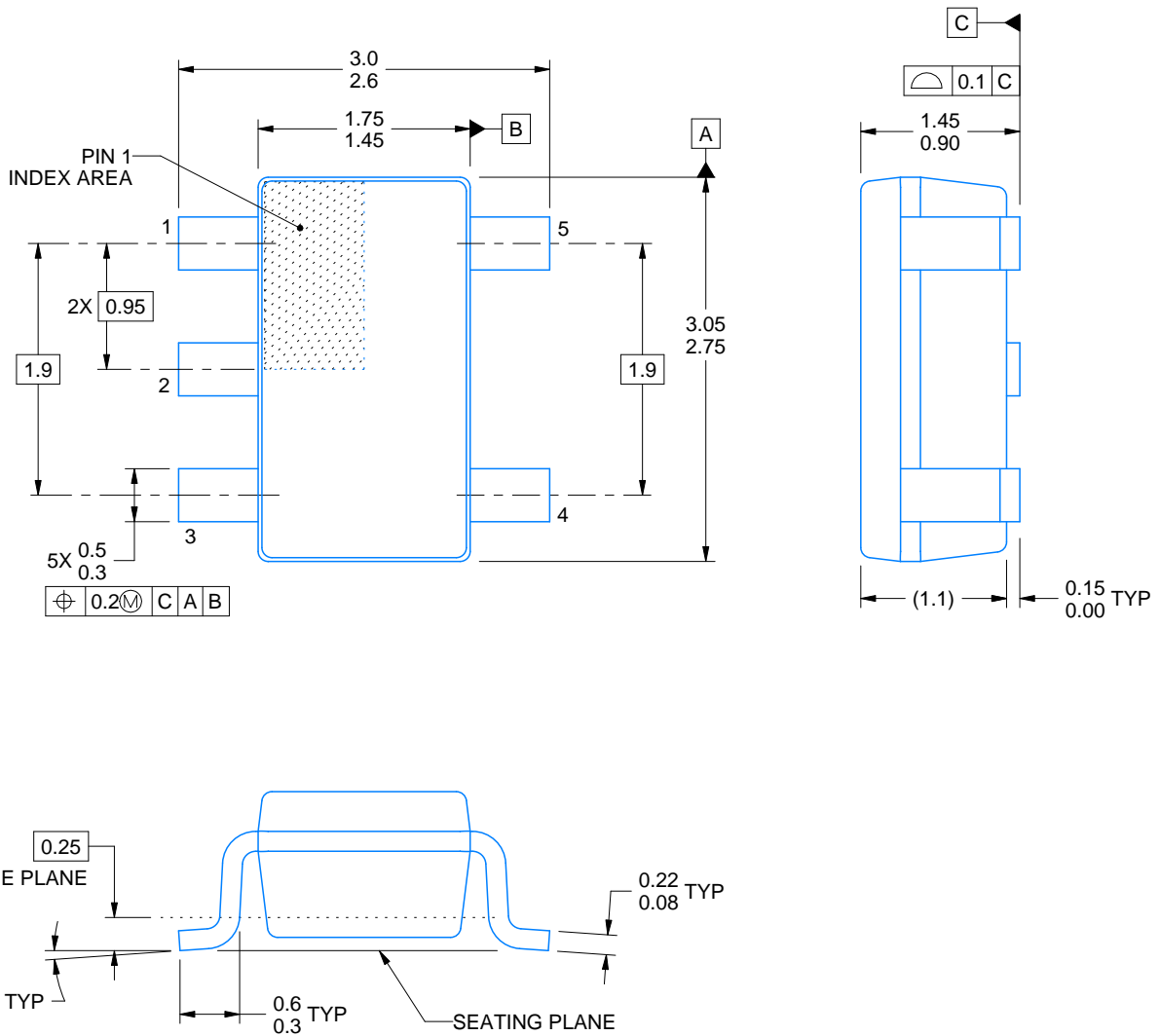

4214839/F 06/2021

### NOTES:

1. All linear dimensions are in millimeters. Any dimensions in parenthesis are for reference only. Dimensioning and tolerancing per ASME Y14.5M.
2. This drawing is subject to change without notice.
3. Reference JEDEC MO-178.
4. Body dimensions do not include mold flash, protrusions, or gate burrs. Mold flash, protrusions, or gate burrs shall not exceed 0.25 mm per side.

# EXAMPLE BOARD LAYOUT

DBV0005A

SOT-23 - 1.45 mm max height

SMALL OUTLINE TRANSISTOR



LAND PATTERN EXAMPLE  
EXPOSED METAL SHOWN  
SCALE:15X



SOLDER MASK DETAILS

4214839/F 06/2021

NOTES: (continued)

- 5. Publication IPC-7351 may have alternate designs.
- 6. Solder mask tolerances between and around signal pads can vary based on board fabrication site.

# EXAMPLE STENCIL DESIGN

DBV0005A

SOT-23 - 1.45 mm max height

SMALL OUTLINE TRANSISTOR



SOLDER PASTE EXAMPLE  
BASED ON 0.125 mm THICK STENCIL  
SCALE:15X

4214839/F 06/2021

NOTES: (continued)

7. Laser cutting apertures with trapezoidal walls and rounded corners may offer better paste release. IPC-7525 may have alternate design recommendations.
8. Board assembly site may have different recommendations for stencil design.

## 重要声明和免责声明

TI“按原样”提供技术和可靠性数据（包括数据表）、设计资源（包括参考设计）、应用或其他设计建议、网络工具、安全信息和其他资源，不保证没有瑕疵且不做任何明示或暗示的担保，包括但不限于对适销性、某特定用途方面的适用性或不侵犯任何第三方知识产权的暗示担保。

这些资源可供使用 TI 产品进行设计的熟练开发人员使用。您将自行承担以下全部责任：(1) 针对您的应用选择合适的 TI 产品，(2) 设计、验证并测试您的应用，(3) 确保您的应用满足相应标准以及任何其他功能安全、信息安全、监管或其他要求。

这些资源如有变更，恕不另行通知。TI 授权您仅可将这些资源用于研发本资源所述的 TI 产品的应用。严禁对这些资源进行其他复制或展示。您无权使用任何其他 TI 知识产权或任何第三方知识产权。您应全额赔偿因在这些资源的使用中对 TI 及其代表造成的任何索赔、损害、成本、损失和债务，TI 对此概不负责。

TI 提供的产品受 [TI 的销售条款](#) 或 [ti.com](#) 上其他适用条款/TI 产品随附的其他适用条款的约束。TI 提供这些资源并不会扩展或以其他方式更改 TI 针对 TI 产品发布的适用的担保或担保免责声明。

TI 反对并拒绝您可能提出的任何其他或不同的条款。

邮寄地址：Texas Instruments, Post Office Box 655303, Dallas, Texas 75265  
Copyright © 2021，德州仪器 (TI) 公司

## X-ON Electronics

Largest Supplier of Electrical and Electronic Components

*Click to view similar products for [Precision Amplifiers](#) category:*

*Click to view products by [Texas Instruments](#) manufacturer:*

Other Similar products are found below :

[LM201AN](#) [MCP6V52-E/MS](#) [ADA4692-4ARUZ-RL](#) [EL8176FSZ](#) [ISL28158FHZ-T7](#) [ISL28236FBZ](#) [ISL28236FBZ-T7](#) [ISL28258FUZ](#)  
[ISL28258FUZ-T7](#) [ISL28276FBZ](#) [ISL28276IAZ](#) [ISL28276IAZ-T7](#) [ISL28288FUZ](#) [NCS21914DR2G](#) [NCS21914DTBR2G](#) [RS8654XP](#)  
[AD8615AUJZ-REEL](#) [HG2376M/TR](#) [MS8362M](#) [LT1013IS8#TRPBF](#) [ADA4610-4ARZ-R7](#) [TP5591-TR](#) [AD8652ARZ-REEL](#) [AD8639ARZ-](#)  
[REEL](#) [ADA4622-2ARZ-RL](#) [LTC6241HVCS8#TRPBF](#) [LT6011IS8#TRPBF](#) [LT6230IS6-10#TRPBF](#) [LT6011IMS8#TRPBF](#)  
[LTC6246CS6#TRMPBF](#) [LT6230CS6#TRPBF](#) [ADA4610-2BRZ-RL](#) [LTC2054HS5#TRPBF](#) [LT6235IGN#TRPBF](#) [LTC6362IDD#TRPBF](#)  
[AD8625ARUZ-REEL](#) [LTC2050HVIS8#TRPBF](#) [AD8627AKSZ-REEL](#) [LT6220IS5#TRPBF](#) [LT6236IS6#TRPBF](#) [OP213ESZ-REEL](#)  
[ADA4092-4ARUZ-RL](#) [CBM8532AMS8](#) [CBM8628AST5](#) [CBM8534AS14](#) [CBM8608AS14](#) [CBM8534ATS14](#) [CBM8605AST5](#)  
[CBM8629AS8](#) [CBM8608ATS14](#)