

## PGA460 超声波信号处理器和传感器驱动器

### 1 特性

- 适用于超声波传感的完全集成式解决方案
- 带可配置电流限制的互补低侧驱动器，支持适用于变压器励磁的基于变压器的拓扑和直接驱动拓扑
- 适用于突发/侦听的单一变送器，或一个变送器对，一个适用于突发，另一个适用于侦听操作
- 可编程 6 点时变增益（32 到 90 dB）低噪声接收器，带用于回波包络检测的 DSP（BPF，解调）
- 12 点时变阈值的两个预设，适用于物体检测
- 用于测量多回声距离和时长的计时器
- 集成温度传感器
- 适用于最远距离达 11 米的物体检测的记录时间
- 用于回声录制的 128 字节 RAM
- 用于存储快速初始化配置的 42 字节用户 EEPROM
- 1 线高电压时间指令接口或 USART 异步接口
- CMOS 电平 USART 接口
- 传感器诊断（衰减频率和时间，励磁电压）、电源和收发器诊断。

### 2 应用

- 超声波雷达
- 物体距离和位置感应
- 存在和接近检测
- 无人机和机器人着陆辅助及障碍物检测
- 占位传感器和运动传感器

### 3 说明

该PGA460设备是高度集成的片上系统超声波变送器驱动器和信号调节器，配备先进的 DSP 内核。该设备具有一个互补低侧驱动器对，可以在基于变压器的拓扑中使用升压变压器驱动变送器，或在直接驱动拓扑中使用外部高侧 FET 驱动变送器。该设备可以接收和调节反射的回波信号，以实现物体的可靠检测。此功能是使用包含一个低噪声放大器以及一个馈送到 ADC 的可编程时变增益级模拟前端 (AFE) 实现的。使用时变阈值在 DSP 内核中处理数字化信号，以实现近场和远场物体检测。

与外部控制器的主要通信将通过 IO 引脚上的时间指令接口 (TCI) 或 1 线 USART 异步接口，或者 RXD 和 TXD 引脚上的 CMOS 电平 USART 接口实现。

PGA460 可进入超低静态电流低功耗模式以减少闲置时的功耗，并且可在通信接口上使用指令将其唤醒。

PGA460 还包括片上系统诊断（可监控突发期间的变送器电压、变送器的频率和衰减时间，以提供有关励磁完整性的信息）和适用于过压、欠压、过流和短路情形的电源侧和收发器侧诊断。

器件信息(1)

器件型号	封装	封装尺寸 (标称值)
PGA460	TSSOP (16)	5.00mm × 4.40mm

(1) 如需了解所有可用封装，请参阅数据表末尾的可订购产品附录。

典型应用图 (变压器驱动器)

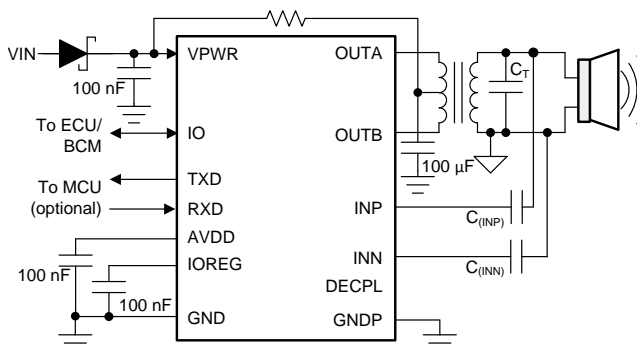

## 目录

<b>1</b>	<b>特性</b> .....	<b>1</b>	<b>7</b>	<b>Detailed Description</b> .....	<b>10</b>
<b>2</b>	<b>应用</b> .....	<b>1</b>	7.1	Overview .....	10
<b>3</b>	<b>说明</b> .....	<b>1</b>	7.2	Functional Block Diagram .....	11
<b>4</b>	<b>修订历史记录</b> .....	<b>2</b>	7.3	Feature Description .....	11
<b>5</b>	<b>Pin Configuration and Functions</b> .....	<b>4</b>	7.4	Device Functional Modes .....	53
<b>6</b>	<b>Specifications</b> .....	<b>5</b>	7.5	Programming .....	53
6.1	Absolute Maximum Ratings .....	5	7.6	Register Maps .....	56
6.2	ESD Ratings .....	5	<b>8</b>	<b>Application and Implementation</b> .....	<b>104</b>
6.3	Recommended Operating Conditions .....	5	8.1	Application Information .....	104
6.4	Thermal Information .....	6	8.2	Typical Applications .....	104
6.5	Internal Supply Regulators Characteristics .....	6	<b>9</b>	<b>Power Supply Recommendations</b> .....	<b>110</b>
6.6	Transducer Driver Characteristics .....	6	<b>10</b>	<b>Layout</b> .....	<b>111</b>
6.7	Transducer Receiver Characteristics .....	7	10.1	Layout Guidelines .....	111
6.8	Analog to Digital Converter Characteristics .....	7	10.2	Layout Example .....	111
6.9	Digital Signal Processing Characteristics .....	7	<b>11</b>	<b>器件和文档支持</b> .....	<b>112</b>
6.10	Temperature Sensor Characteristics .....	7	11.1	文档支持 .....	112
6.11	High-Voltage I/O Characteristics .....	7	11.2	接收文档更新通知 .....	112
6.12	Digital I/O Characteristics .....	8	11.3	社区资源 .....	112
6.13	EEPROM Characteristics .....	8	11.4	商标 .....	112
6.14	Timing Requirements .....	8	11.5	静电放电警告 .....	112
6.15	Switching Characteristics .....	9	11.6	术语表 .....	112
6.16	Typical Characteristics .....	9	<b>12</b>	<b>机械、封装和可订购信息</b> .....	<b>112</b>

## 4 修订历史记录

注：之前版本的页码可能与当前版本有所不同。

### Changes from Revision A (August 2017) to Revision B

**Page**

• Changed Functional Block Diagram's GND and GNDP pin designators for correct grounding of the Output Driver. ....	11
• Updated tablenotes of <a href="#">表 3</a> .....	38
• Added sentence: USART Synchronous Mode is identical to a Serial Peripheral Interface (SPI) without a chip-select because the addressing is handled by the three-bit UART_ADDR value to enable up to eight devices on a single bus. ...	43
• Added sentence: The temperature measurement's sample and conversion time requires at least 100 us after the temperature measurement command is issued. Do not send other commands during this time to allow the temperature value to properly update .....	50

### Changes from Original (April 2017) to Revision A

**Page**

• Added zero padding information to the <i>CONFIGURATION/STATUS Command</i> section .....	32
• Changed UART interface parameter text from: 1 stop bit to: 2 stop bit .....	34
• Changed interfield wait time text from: optional to: required for 1 stop bit .....	34
• Added sentence: The sync field (0x55) is not included as part of the checksum calculation. ....	37
• Updated content and added tablenotes to <a href="#">表 3</a> .....	38
• Added sentence: The diagnostic field is included in the slave generated checksum calculation. ....	41
• Added subsection <i>Direct Data Burst Through USART Synchronous Mode</i> .....	46
• Added <a href="#">公式 8</a> .....	51
• Added sentence: This includes all threshold timing and level values. ....	53
• Updated <i>UART and USART Communication Examples</i> content .....	56
• Updated content in <a href="#">表 101</a> .....	106
• Added content to <i>Application Curves</i> .....	108
• Added content to <i>Direct-Driven (Transformer-Less) Method</i> and changed <a href="#">图 141</a> such that a GND node is present	

---

at $XDCR_{Negative}$ and $C_{INN}$ .....	109
• Changed text from: TDK EPCOS B78416A2232A03 Transformer, muRata MA40H1S-R transducer to: Fairchild FDC6506P p-channel MOSFET, muRata MA40H1S-R transducer .....	110

---

## 5 Pin Configuration and Functions

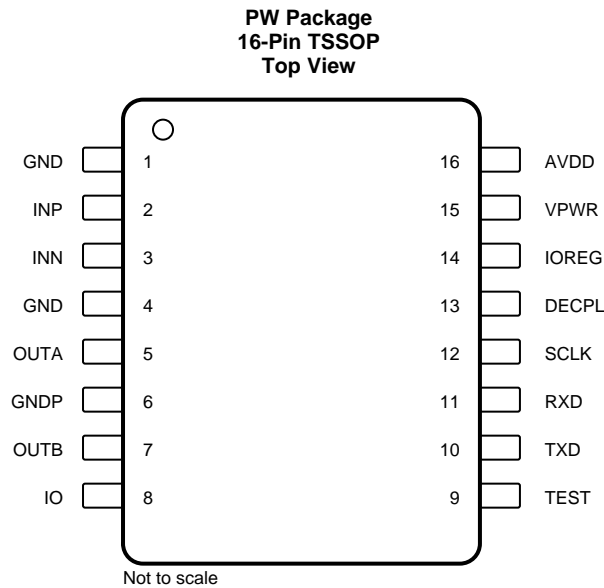

### Pin Functions

PIN		TYPE <sup>(1)</sup>	DESCRIPTION
NO.	NAME		
1	GND	P	Ground
2	INP	I	Positive transducer receive
3	INN	I	Negative transducer receive
4	GND	P	Ground
5	OUTA	O	Transducer driver output A
6	GNDP	P	Power ground
7	OUTB	O	Transducer driver output B
8	IO	I/O	Time-command interface data input and output
9	TEST	I/O	Test output pin
10	TXD	O	USART interface transmit
11	RXD	I	USART interface receive
12	SCLK	I	USART synchronous-mode clock input
13	DECPL	O	Decoupling transistor gate drive
14	IOREG	P	I/O buffer voltage regulator capacitor
15	VPWR	P	Power-supply voltage
16	AVDD	P	Analog voltage-regulator capacitor

(1) I = input, O = output, I/O = input and output, P = power

## 6 Specifications

### 6.1 Absolute Maximum Ratings

over operating free-air temperature range (unless otherwise noted)<sup>(1)</sup>

		MIN	MAX	UNIT
Input voltage	VPWR	-0.3	30	V
	IO	-0.3	30	
	INP, INN	-0.3	2	V
	TEST, SCLK, RXD	-0.3	5.5	V
Output voltage	AVDD	-0.3	2	V
	IOREG, DECPL, TEST, TXD	-0.3	5.5	
	OUTA, OUTB	-0.3	30	
Ground voltage	GNDP, GND	-0.3	0.3	V
Sink current	OUTA, OUTB		500	mA
Operating junction temperature		-40	125	°C
Storage temperature, T <sub>stg</sub>		-40	125	°C

(1) Stresses beyond those listed under *Absolute Maximum Ratings* may cause permanent damage to the device. These are stress ratings only, which do not imply functional operation of the device at these or any other conditions beyond those indicated under *Recommended Operating Conditions*. Exposure to absolute-maximum-rated conditions for extended periods may affect device reliability.

### 6.2 ESD Ratings

		VALUE	UNIT
V <sub>(ESD)</sub> Electrostatic discharge	Human-body model (HBM), per ANSI/ESDA/JEDEC JS-001 <sup>(1)</sup>		±2000
	Charged-device model (CDM), per JEDEC specification JESD22-C101 <sup>(2)</sup>	Corner Pins (1, 8, 9, 16)	±750
		All Other Pins	±500
	IEC 61000-4-2 contact discharge		IO pin

(1) JEDEC document JEP155 states that 500-V HBM allows safe manufacturing with a standard ESD control process.

(2) JEDEC document JEP157 states that 250-V CDM allows safe manufacturing with a standard ESD control process.

### 6.3 Recommended Operating Conditions

Over operating free-air temperature range (unless otherwise noted).

		MIN	MAX	UNIT
V <sub>VPWR_XF</sub>	Supply input for transformer topology	6	15	V
V <sub>VPWR_DD</sub>	Supply input for direct drive topology	6	28	V
V <sub>IO</sub>	IO pin	IO	V <sub>PWR</sub>	V
V <sub>INx</sub>	Transducer receive input	INP, INN	0.9	V
V <sub>DIG_IO</sub>	Digital I/O pins	RXD, TEST, SCLK	V <sub>IOREG</sub>	V
V <sub>GND</sub>	Ground pins	GNDP, GND	0.1	V
I <sub>LPM</sub>	V <sub>PWR</sub> Input current	Low Power Mode Enabled	500	µA
I <sub>BURST</sub>		During Ultrasonic Burst	500	mA
T <sub>A</sub>	Operating free-air temperature	-40	105	°C
T <sub>J</sub>	Operating junction temperature	-40	125	°C

## 6.4 Thermal Information

THERMAL METRIC <sup>(1)</sup>		PGA460		UNIT
		PW (TSSOP)		
		16 PINS		
R <sub>θJA</sub>	Junction-to-ambient thermal resistance	96.1		°C/W
R <sub>θJC(top)</sub>	Junction-to-case (top) thermal resistance	24.6		°C/W
R <sub>θJB</sub>	Junction-to-board thermal resistance	42		°C/W
ψ <sub>JT</sub>	Junction-to-top characterization parameter	0.8		°C/W
ψ <sub>JB</sub>	Junction-to-board characterization parameter	41.3		°C/W

(1) For more information about traditional and new thermal metrics, see the [Semiconductor and IC Package Thermal Metrics](#) application report.

## 6.5 Internal Supply Regulators Characteristics

PARAMETER		TEST CONDITIONS	MIN	TYP	MAX	UNIT
V <sub>AVDD</sub>	Internal analog supply voltage	I <sub>AVDD</sub> = 5 mA	1.74	1.8	1.9	V
I <sub>VPWR_RX_ONLY</sub>	Supply current from VPWR pin during listen only mode.	V <sub>VPWR</sub> = 14 V; no bursting; Listen only active		12		mA
V <sub>IOREG_33</sub>	Digital IO supply voltage	V <sub>TEST</sub> = 0 V during power-up; I <sub>IOREG</sub> = 2 mA	2.95	3.3	3.65	V
V <sub>IOREG_50</sub>		V <sub>TEST</sub> ≥ 2 V during power-up; I <sub>IOREG</sub> = 2 mA; V <sub>VPWR</sub> > 7.5 V	4.45	5	5.65	
I <sub>LIM_AVDD</sub>	AVDD current limit	AVDD short to GND	40		150	mA
I <sub>LIM_IOREG</sub>	IOREG current limit	IOREG short to GND	10		50	mA
V <sub>OV_AVDD</sub>	AVDD overvoltage threshold		1.95		2.3	V
V <sub>UV_AVDD</sub>	AVDD undervoltage threshold		1.29		1.53	V
V <sub>OV_IOREG_33</sub>	IOREG overvoltage threshold	V <sub>TEST</sub> = 0 V during power-up	3.6		4.6	V
V <sub>UV_IOREG_33</sub>	IOREG undervoltage threshold	V <sub>TEST</sub> = 0 V during power-up	2.57		2.9	V
V <sub>UV_IOREG_50</sub>		V <sub>TEST</sub> ≥ 2 V during power-up	3.8		4.5	
V <sub>OV_VPWR</sub>	VPWR overvoltage threshold	VPWR_OV_TH = 0x0	11	12.3	15	V
		VPWR_OV_TH = 0x1	16	17.7	21	
		VPWR_OV_TH = 0x2	21.5	22.8	27	
		VPWR_OV_TH = 0x3	27	28.3	31	
V <sub>UV_VPWR</sub>	VPWR undervoltage threshold		5.25		6	V
t <sub>ON_REG</sub>	AVDD and IOREG power-up time	V <sub>VPWR</sub> = 6 V			10	ms

## 6.6 Transducer Driver Characteristics

PARAMETER		TEST CONDITIONS	MIN	TYP	MAX	UNIT
V <sub>CLAMP_DRV</sub>	Driver clamping voltage	Driver switched off	30			V
I <sub>PULSE_MAX_DRV</sub>	Maximum driver pulse current	V <sub>OUTA</sub> , V <sub>OUTB</sub> = 6 V; F <sub>SW</sub> = 30 kHz; T <sub>A</sub> = 105°C			500	mA
R <sub>DS(on)_DRV</sub>	MOSFET on resistance	I <sub>DRAIN</sub> = 500 mA; T <sub>A</sub> = 105°C; DIS_CL=1		4.8	8	Ω
E <sub>DIS_BURST</sub>	Energy dissipated during burst				6.4	mJ
I <sub>LEAK_DRV</sub>	Leakage current	V <sub>OUTA</sub> , V <sub>OUTB</sub> = 14 V	-1		1	μA
I <sub>CLAMP_DRV_0</sub>	Current clamping range for minimum code setting	V <sub>VPWR</sub> > 7 V; CURR_LIM1 = CURR_LIM2 = 0	15	50	75	mA
I <sub>CLAMP_DRV_63</sub>	Current clamping range from maximum code setting	V <sub>VPWR</sub> > 7 V; CURR_LIM1 = CURR_LIM2 = 63	450	500	570	mA
I <sub>STEP_SIZE_CLAMP_DRV</sub>	Step size (change in current from value at previous step)		5.2	7.2	9.2	mA

## Transducer Driver Characteristics (continued)

PARAMETER		TEST CONDITIONS	MIN	TYP	MAX	UNIT
$f_{SW\_LOW}$	Configurable switching frequency	FREQ_SHIFT = 0	30		80	kHz
$f_{SW\_HIGH}$		FREQ_SHIFT = 1	180		480	

## 6.7 Transducer Receiver Characteristics

PARAMETER		TEST CONDITIONS	MIN	TYP	MAX	UNIT
$GAIN_{RNG\_TOT\_RCV}$	Total receiver amplification gain range	$F_{SW} = F_{SW\_LOW}, F_{SW\_HIGH}; T_A = -40^{\circ}C$ to $+105^{\circ}C$	32		90	dB
$GAIN_{RNG\_RCV}$	Receiver amplification gain	AFE_GAIN_RNG = 0x03	32		64	
		AFE_GAIN_RNG = 0x02	46		78	
		AFE_GAIN_RNG = 0x01	52		84	
		AFE_GAIN_RNG = 0x00	58		90	
$GAIN_{NSTEP\_RCV}$	Gain adjustment steps			64		
$GAIN_{STEP\_SIZE\_RCV}$	Gain adjustment step size		0.2	0.5	0.8	dB
$GAIN_{THRM\_DRFT\_RCV}$	Gain thermal drift	$F_{SW} = 30$ kHz; $T_A = -40^{\circ}C$ to $+105^{\circ}C$ ; Gain = 58.5 dB	-3.5%		3.5%	
$Z_{INP\_RCV}$	Input impedance	$F_{SW} < 80$ kHz	300			k $\Omega$
$N_{RCV}$	Noise floor	$F_{SW} = 58$ kHz; $T_A = 105^{\circ}C$ ; BW = 4 kHz		7		nV/sqrt(Hz)

## 6.8 Analog to Digital Converter Characteristics

PARAMETER		TEST CONDITIONS	MIN	TYP	MAX	UNIT
$V_{INP\_ADC}$	Input voltage range		0		$V_{AVDD}$	V
$V_{REF\_ADC}$	Voltage reference			$V_{AVDD}$		
$N_{ADC}$	Resolution			12		Bits
$t_{CONV}$	Conversion time			1		$\mu$ s

## 6.9 Digital Signal Processing Characteristics

PARAMETER		TEST CONDITIONS	MIN	TYP	MAX	UNIT
$FREQ_{CENTER\_BPF}$	Band-pass filter center frequency	Normalized to driver frequency		1		
$BW_{BPF}$	Band-pass filter band width		2		8	kHz
$N_{BPF}$	Band-pass filter adjustable steps			4		
$FREQ_{STEP\_SIZE\_BPF}$	Band-pass filter step size			2		kHz
$FREQ_{CUTOFF\_LPF}$	Low-pass filter cutoff frequency		1		4	kHz
$N_{LPF}$	Low-pass filter adjustable steps			4		
$FREQ_{STEP\_SIZE\_LPF}$	Low-pass filter step size			1		kHz

## 6.10 Temperature Sensor Characteristics

PARAMETER		TEST CONDITIONS	MIN	TYP	MAX	UNIT
$T_{RANGE\_SENSE}$	Temperature sensor range		-40		125	$^{\circ}C$
$T_{ACC\_SENSE}$	Range accuracy	VPWR=12 V; TEMP_GAIN = 0; TEMP_OFF = 0		5		$^{\circ}C$

## 6.11 High-Voltage I/O Characteristics

PARAMETER		TEST CONDITIONS	MIN	TYP	MAX	UNIT
$V_{IH\_IO}$	High-voltage IO input high level	IO pin	$0.6 \times V_{VPWR}$			V

## High-Voltage I/O Characteristics (continued)

PARAMETER		TEST CONDITIONS	MIN	TYP	MAX	UNIT
V <sub>IL_IO</sub>	High-voltage IO input low level	IO pin			0.4 × V <sub>VPWR</sub>	V
V <sub>HYS_IO</sub>	High-voltage input hysteresis	IO pin	0.05 × VPWR		0.175 × VPWR	V
V <sub>OL_IO</sub>	High-voltage IO output low level	IO pin ; I <sub>IO</sub> = 10 mA			2	V
R <sub>PU_IO</sub>	High-voltage IO pullup resistance	IO pin	4	10	16	kΩ
I <sub>LIM_IO</sub>	Current limit on high-voltage IO	Short to VPWR	40		250	mA

## 6.12 Digital I/O Characteristics

PARAMETER		TEST CONDITIONS	MIN	TYP	MAX	UNIT
V <sub>IH_DIGIO</sub>	Digital input high level	RX and SCLK pin; V <sub>IOREG</sub> = V <sub>IOREG_33</sub> /V <sub>IOREG_50</sub>	0.7 × V <sub>IO</sub> REG			V
V <sub>IL_DIGIO</sub>	Digital input low level	RX and SCLK pin; V <sub>IOREG</sub> = V <sub>IOREG_33</sub> /V <sub>IOREG_50</sub>			0.3 × V <sub>IO</sub> REG	V
V <sub>HYS_DIGIO</sub>	Digital input hysteresis	RX and SCLK pin	100			mV
V <sub>OH_DIGIO</sub>	Digital output high level	DECPL and TX pin; I <sub>DECPL/ITX</sub> = -2 mA; V <sub>IOREG</sub> = V <sub>IOREG_33</sub> /V <sub>IOREG_50</sub>	V <sub>IOREG</sub> - 0.2			V
V <sub>OL_DIGIO</sub>	Digital output low level	DECPL and TX pin; I <sub>DECPL/ITX</sub> = 2mA			0.2	V
R <sub>PU_DIGIO_RX</sub>	Digital input pull-up resistance to IOREG	RX pin	90	100	160	kΩ
R <sub>PU_DIGIO_SCLK</sub>	Digital input pull-down resistance	SCLK pin	80	100	130	kΩ

## 6.13 EEPROM Characteristics

PARAMETER		TEST CONDITIONS	MIN	TYP	MAX	UNIT
Bytes <sub>EE</sub>	EEPROM memory size	Application and Device Internal		64		Bytes
t <sub>RET_EE</sub>	EEPROM data retention time	T <sub>A</sub> = 105°C			10	Years
Cycl <sub>BURN_EE</sub>	EEPROM burn cycles				1000	Cycles
t <sub>PROG_EE</sub>	EEPROM programming time			600		ms

## 6.14 Timing Requirements

		MIN	NOM	MAX	UNIT
<b>TIME COMMAND INTERFACE</b>					
t <sub>BIT_TCI</sub>	Bit period	225	300	375	μs
t <sub>BIT0_TCI</sub>	Logical 0 bit length	150	200	250	μs
t <sub>BIT1_TCI</sub>	Logical 1 bit length	75	100	125	μs
t <sub>BLP1_TCI</sub>	BURST/LISTEN (Preset1) command period	328	400	472	μs
t <sub>BLP2_TCI</sub>	BURST/LISTEN (Preset2) command period	920	1010	1100	μs
t <sub>LP1_TCI</sub>	LISTEN only (Preset1) command period	697	780	863	μs
t <sub>LP2_TCI</sub>	LISTEN only (Preset2) command period	503	580	657	μs
t <sub>CFG_TCI</sub>	Device configuration command period	1170	1270	1370	μs
t <sub>TEMP_TCI</sub>	Temperature measurement command period	1440	1550	1660	μs
t <sub>NOISE_TCI</sub>	Noise level measurement command period	2070	2200	2340	μs
t <sub>DT_TCI</sub>	Command processing dead-time	75	100	125	μs
<b>USART ASYNCHRONOUS INTERFACE</b>					
t <sub>BIT_UART</sub>	Logical bit length at 19.2 kbps	45.5	52.08	58.6	μs
t <sub>BITF_UART</sub>	Logical bit length at 115.2 kbps	7.6	8.68	9.76	μs
<b>USART SYNCHRONOUS INTERFACE</b>					
t <sub>BIT_USART</sub>	Logical bit length at 8 Mbps	55	125		ns



### 6.15 Switching Characteristics

PARAMETER	TEST CONDITIONS	MIN	TYP	MAX	UNIT
f <sub>CORE_CLK</sub>	Core frequency <sup>(1)</sup>	15.5	16	16.5	MHz
ACC <sub>CORE_CLK</sub>	Core frequency accuracy <sup>(2)</sup>	-4%		4%	
Baud <sub>UART</sub>	USART asynchronous interface baud rate	2.4	19.2	131.5	kbps
Baud <sub>USART</sub>	USART interface synchronous mode baud rate			8	Mbps

- (1) At Room Temperature (25°C)
- (2) Across Operating Temperature Range (-40°C to 105°C)

### 6.16 Typical Characteristics

10 pulses, 400-mA current limit, 58.6-kHz driving frequency

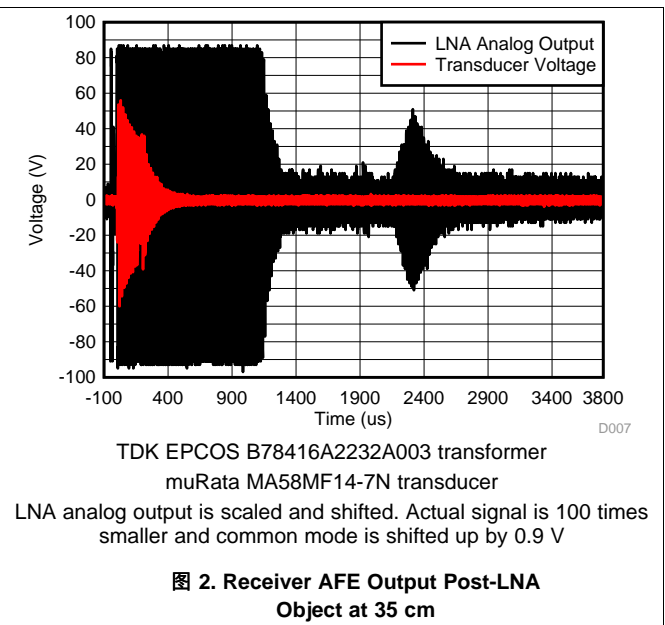
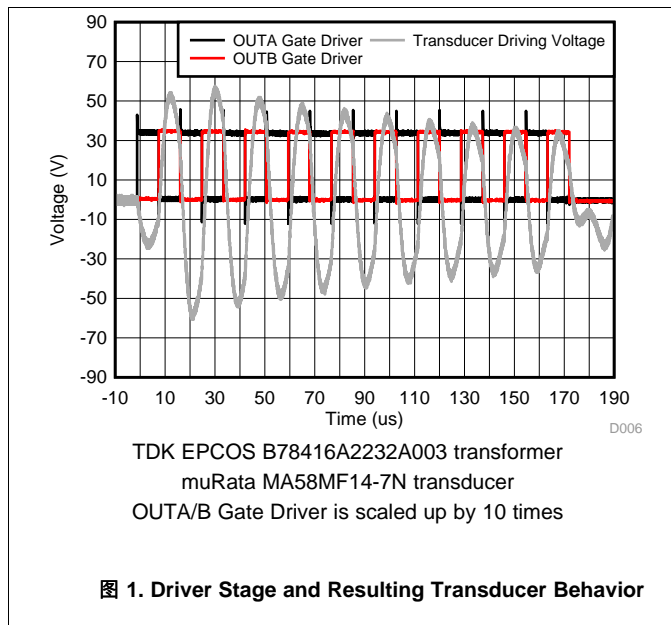

## 7 Detailed Description

### 7.1 Overview

The PGA460 device is a signal-conditioning and transducer-driver device for ultrasonic sensing for object or distance sensing. The output driver consists of complimentary low-side drivers capable of driving a center-tap transformer to generate large excitation voltages across an ultrasonic transducer and as a result create the desired sound pressure level (SPL). The output driver can also be configured to be used in direct-drive mode without a transformer using external FETs. The output driver implements configurable current limit for efficient driving of the transformer and configurable bursting frequencies and burst length to be compatible with a large number of transducers.

The analog front-end (AFE) can sense the received echo from the transducer and amplify it for correct object detection. The AFE implements a low-noise amplifier followed by a time-varying gain amplifier that allows signals from objects at a variable distance to be amplified correspondingly. This implementation allows for the maximum dynamic range of the ADC to be used for both near-field and far-field objects in the same recording. An embedded temperature sensor can be used to calibrate the signal conditioner for changes in temperature. The digital signal processing path further filters the received echo and uses time-varying thresholds for accurate detection of objects. Two presets for both bursting and thresholds are available which allow faster detection cycles by saving time required to configure the device between multiple bursts. Most configuration parameters are stored in nonvolatile memory for quick power up, which reduces initialization time.

The PGA460 device provides multiple IO protocols to communicate with the master controller. The device provides a time-command interface and one-wire UART on the VPWR reference IO pin. It also provides both synchronous and asynchronous USART on the TXD, RXD, and SCLK pins.

## 7.2 Functional Block Diagram

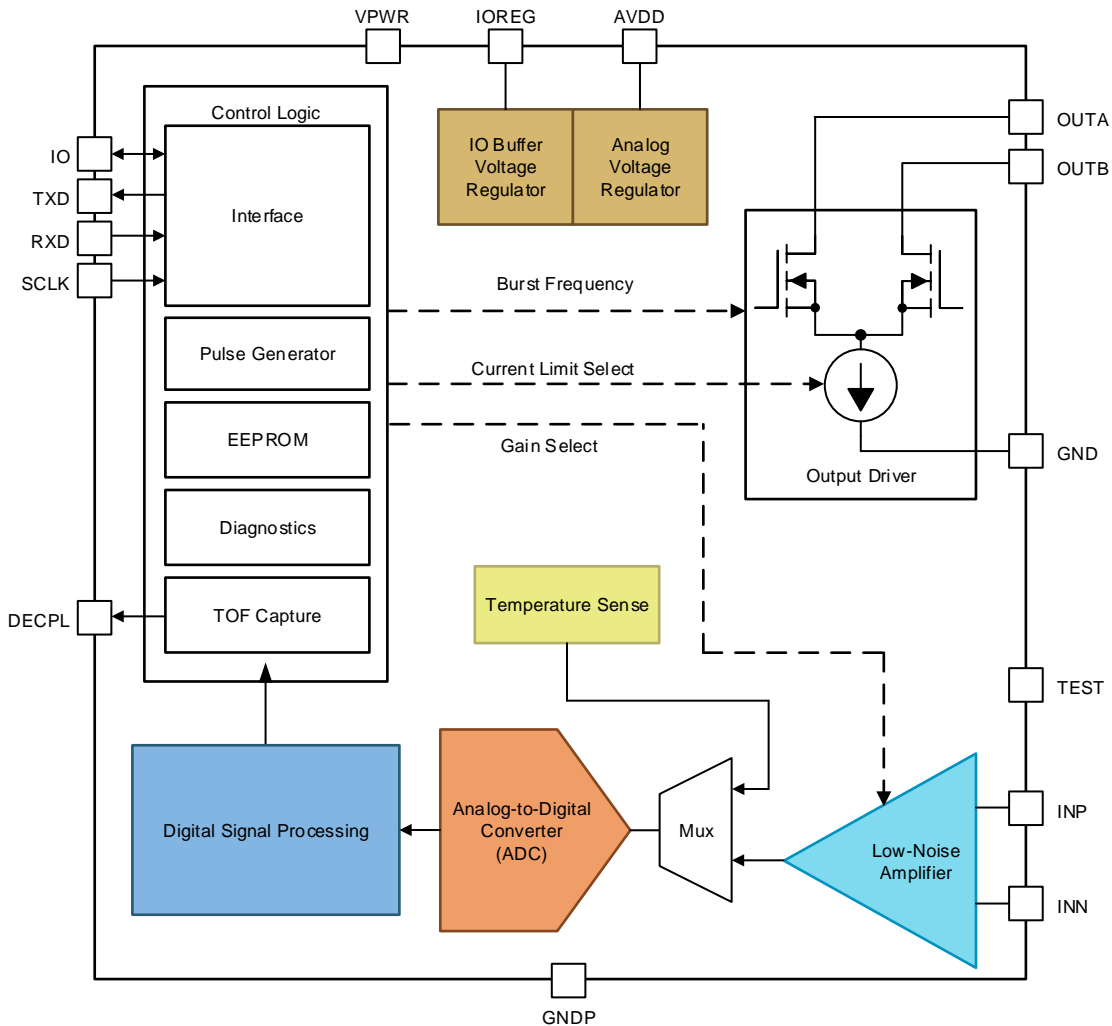

Copyright © 2017, Texas Instruments Incorporated

## 7.3 Feature Description

### 7.3.1 Power-Supply Block

The PGA460 device uses multiple internal regulators as supplies for the internal circuits. The analog voltage regulator (AVDD) requires an external capacitor of 100 nF. The power-supply block generates precision voltage references, current bias, and an internal clock. An additional regulator (IOREG) generates the supply voltage for the USART pins (RXD, TXD, and SCLK), DECPL pin, and TEST pin for their digital functionality. The AVDD and IOREG regulators are not intended to support any external load. The external capacitors are recommended to be placed as close as possible to the related pins (AVDD and IOREG). The PGA460 device starts to power up when a voltage is applied to the VPWR pin. The internal power-on reset (POR) is released when all regulator supplies are in regulation and the internal clock is running. During low-power mode, the IOREG regulator is powered up while the other regulators shut down to conserve power.

## Feature Description (接下页)

### 7.3.2 Burst Generation

The PGA460 device has a programmable frequency for the burst and number of pulse by configuring the `FREQ` and `P1_PULSE/P2_PULSE` registers.

Use [公式 1](#) to calculate the frequency of burst for a range of 30 kHz to 80 kHz (`FREQ_SHIFT` bit set to 0).

$$f_{(DRV)} = 0.2 \text{ kHz} \times f + 30 \text{ kHz}$$

where

- $f$  is the frequency which can be from 0 to 200 as defined in the `FREQUENCY` register. (1)

The actual driving frequency of the output stage is derived from the core clock frequency using [公式 1](#) and [公式 2](#)

$$n = \frac{f_{(CORE\_CLK)}}{f_{(DRV)}}$$

where

- $n$  is the ratio by which the main oscillator  $f_{(CORE\_CLK)}$  is divided. (2)

The `PULSE_P1` and `PULSE_P2` registers can range from 0 to 31. When set to a value of  $M$  that is greater than 0, the  $M$  pulse pairs are generated on the `OUTA` and `OUTB` outputs.

#### 7.3.2.1 Using Center-Tap Transformer

The PGA460 device provides efficient burst generation by exciting the primary side of a center-tap transformer connected on the `OUTA` and `OUTB` pins through the complementary low-side FETs operating in a current limiting mode. The frequency of the burst is from 30 kHz to 80 kHz with the current limit from 50 mA to 500 mA. The frequency of the burst, the current limit for transformer primary current, and the number of burst pulses can be controlled by using the `FREQUENCY`, `CURR_LIM_P1`, `CURR_LIM_P12`, `PULSE_P1`, and `PULSE_P2` parameters, respectively.

[图 3](#) shows the functional block diagram for echo generation.

Feature Description (接下页)

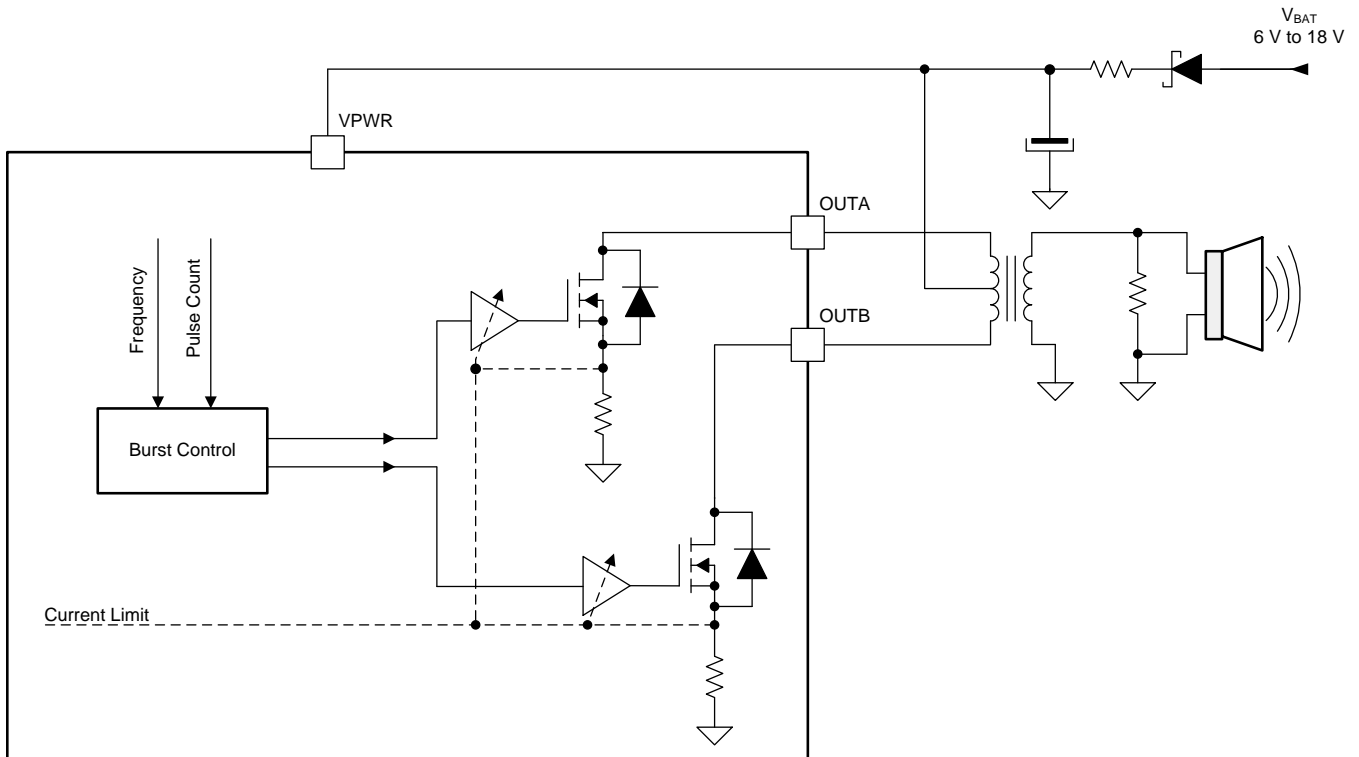

Copyright © 2017, Texas Instruments Incorporated

图 3. Echo Generation Block Diagram

7.3.2.2 Direct Drive

The complementary low-side drivers can be used in conjunction with an external PMOS FET to provide single-ended direct excitation to the transducer. In this configuration, the internal FETs can be used in a RDSON mode by disabling current limiting feature by setting the DIS\_CL bit in the CURR\_LIM\_P1 register.

An additional dead-time feature can be used in this mode to eliminate the shoot-through currents between the external PMOS FET and internal low-side FETs by configuring the PULSE\_DT bit. The burst cycle period of the low-side FETs remains unchanged; however, the deactivation time is reduced by the dead-time programmed value. 图 4 shows this case.

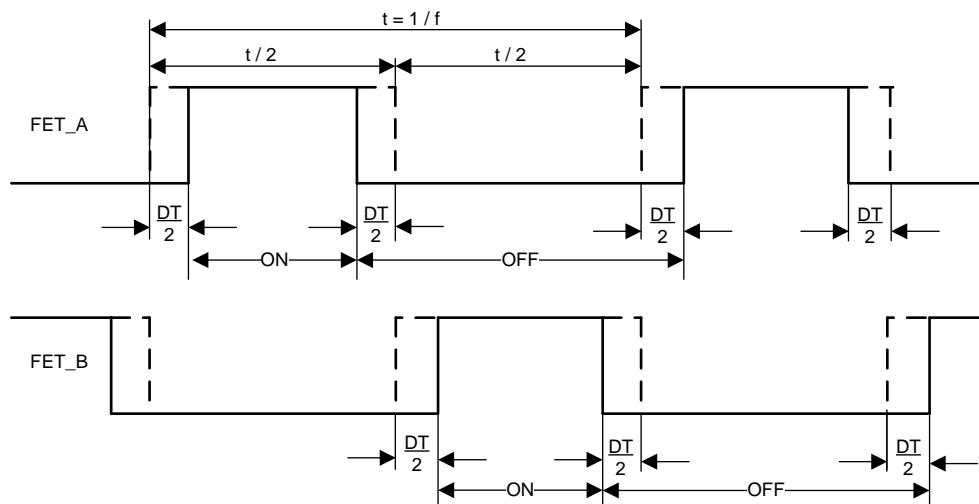
**Feature Description (接下页)**

**图 4. Echo Generation Dead-Time Adjustment**
**7.3.2.3 Other Configurations**

When any of the P1\_PULSE or P2\_PULSE bits are set to 0, only the OUTA output generates a pulse, while the OUTB output remains in the high-impedance (High-Z) state during this period. This configuration is used to reduce the output voltage when only short distances are required to be detected.

**注**

- For higher frequency support, the device has an option to shift up the burst frequency range which occurs by setting the `FREQ_SHIFT` bit in the `CURR_LIM_P1` register. When this bit is set, the burst frequency is 6 times higher of the burst frequency selected by the `FREQUENCY` register. With this bit set, the range of burst frequencies is from 180 kHz to 480 kHz with a step of approximately 1.2 kHz.
- The maximum dead time setting should be less than or equal to  $t / 8$  where  $t$  is burst period.

**7.3.3 Analog Front-End**

The analog front-end (AFE) in the PGA460 device, shown in [图 5](#), receives the reflected echo from the object, amplifies it, and feeds it into a digital signal processing (DSP) data path for echo detection. Because the received echo signal can vary amplitude (in millivolts for near objects and in microvolts for far objects), the first AFE stage is a very low-noise balanced amplifier with a predetermined fixed gain followed by a variable gain-stage amplifier with configurable gain from 32 dB to 90 dB. The amplified echo signal is converted into a digital signal by a 12-bit analog-to-digital converter (ADC) and fed to a DSP processing block for further evaluation and time-of-flight measurement.

The PGA460 AFE implements system diagnostics for sensing element (transducer) monitoring during the burst and decay stage of the echo recording process in a way of measuring the maximum achieved voltage at the transducer node and the frequency of oscillation at the transducer node. For more information on these diagnostics, see the [System Diagnostics](#) section.

Feature Description (接下页)

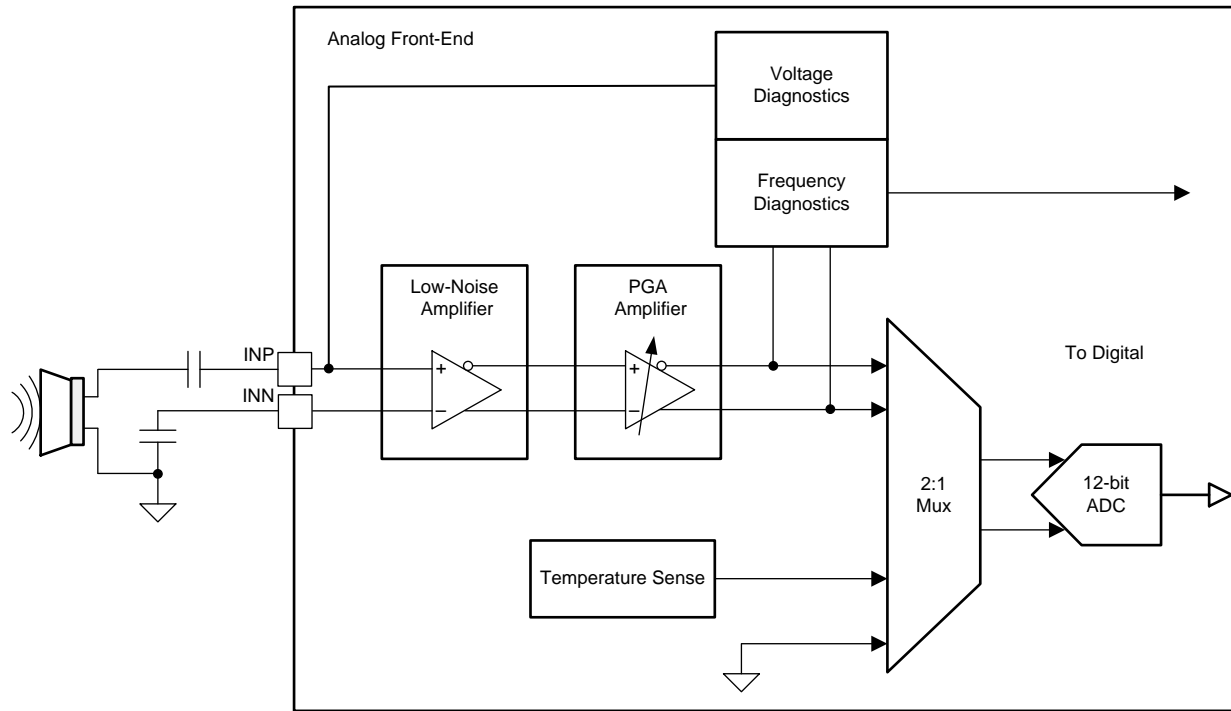

Copyright © 2017, Texas Instruments Incorporated

图 5. Analog Front-End

The variable gain amplifier in the AFE implements a time-varying gain feature which allows the user to set different static gains and also specify a gain profile for the echo listening process (echo record time). This feature allows for a uniform amplification of echo signals from objects at different distances without saturating the ADC. As an example, for closer objects, gain can be programmed lower initially in time and then increased during the recording time to detect farther objects which have a very small echo signal. This feature helps in attaining sufficient SNR after ADC conversion for all distances for accurate time of flight measurement.

The time-varying gain parameters are stored in the EEPROM memory and characterized by:

- The initial fixed-gain parameter, GAIN\_INIT.
- A time-varying gain start-time value stored in the TVGAIN0 register.
- An array of 5 gain-varying cross points placed in the TVGAIN0 to TVGAIN6 registers.

图 6 shows an example plot of the time-varying gain.

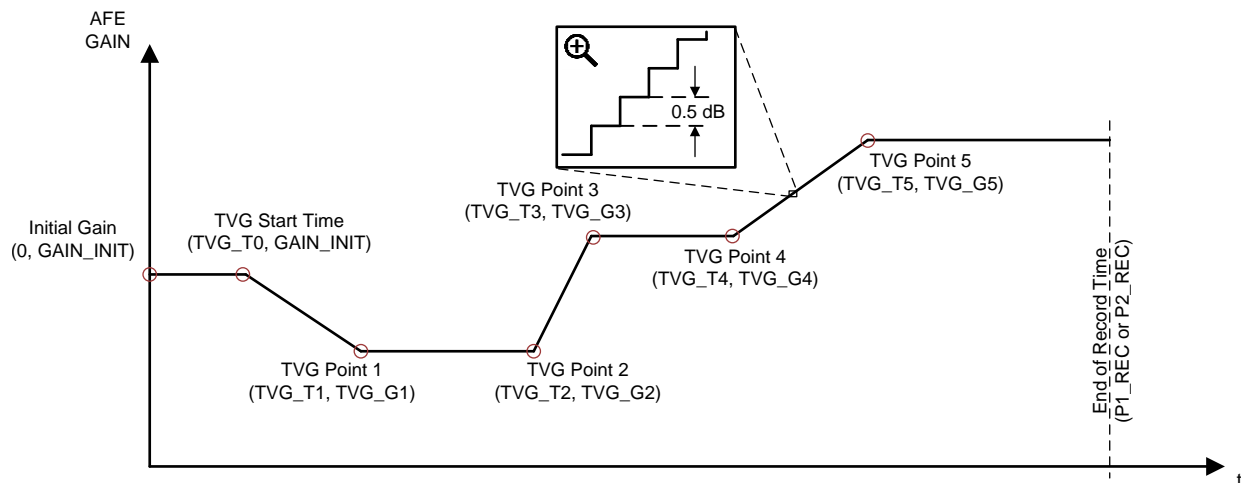
**Feature Description (接下页)**

**图 6. Time-Varying Gain Assignment Example**

The time value, TVG start time, is expressed in terms of absolute time, and all following TVG point times (TVG\_Tx parameters) are expressed as a delta time between the current and previous point. All gain values are expressed in an absolute gain value in dB and are unrelated from each other. The final gain setting of TVG Point 5 (TVG\_G5) will be kept constant until the end of the echo record time. The time-varying gain assignment is the same for both presets. A linear interpolation scheme is used to calculate gain between two TVG points. The AFE gain resolution is 0.5 dB typical.

**注**

The time-varying gain changes during the recording are applied only on the record cycle that follows. If the TVGAIN[0:6] registers programmed to 0x00, the time-varying gain function of the PGA460 device is disabled and a fixed gain defined by the INIT\_GAIN register is applied. In this case, changing the INIT\_GAIN register changes the gain of AFE during the recording.

The offset on the time-varying gain is controlled through the two AFE\_GAIN\_RNG bits in DECPL\_TEMP register. For each of the four settings as defined in the [Register Maps](#) section, the gain can be varied from 0 to 32 dB added on top of the offset.

**7.3.4 Digital Signal Processing**

The DSP block of the PGA460 device processes the digital data from the ADC to extract the peak profile of the echo after which the output of the DSP is compared against the programmed threshold to measure the time of flight for object distance calculation.

图 7 shows the data path of the DSP. Also, the output of the comparator can be deglitched by the THR\_CMP\_DEGLTCH[7:4] bits in the DEADTIME register.





图 7. DSP Data-Path

### 7.3.4.1 Ultrasonic Echo—Band-Pass Filter

The ultrasonic echo signal is an amplitude-modulated signal with an underlying carrier frequency equal to the drive frequency of the ultrasonic transducer. The DSP band-pass filter block allows the frequencies outside of the observed frequency band to be filtered out and therefore reducing the amount of noise influencing the ultrasonic echo signal.

The center frequency of the filter is automatically adjusted based on the driving frequency set by the **FREQ** bit while the bandwidth of the filter can be adjusted from 2 kHz to 8 kHz in steps of 2 kHz by setting the **BPF\_BW** bit in the **INIT\_GAIN** EEPROM register.

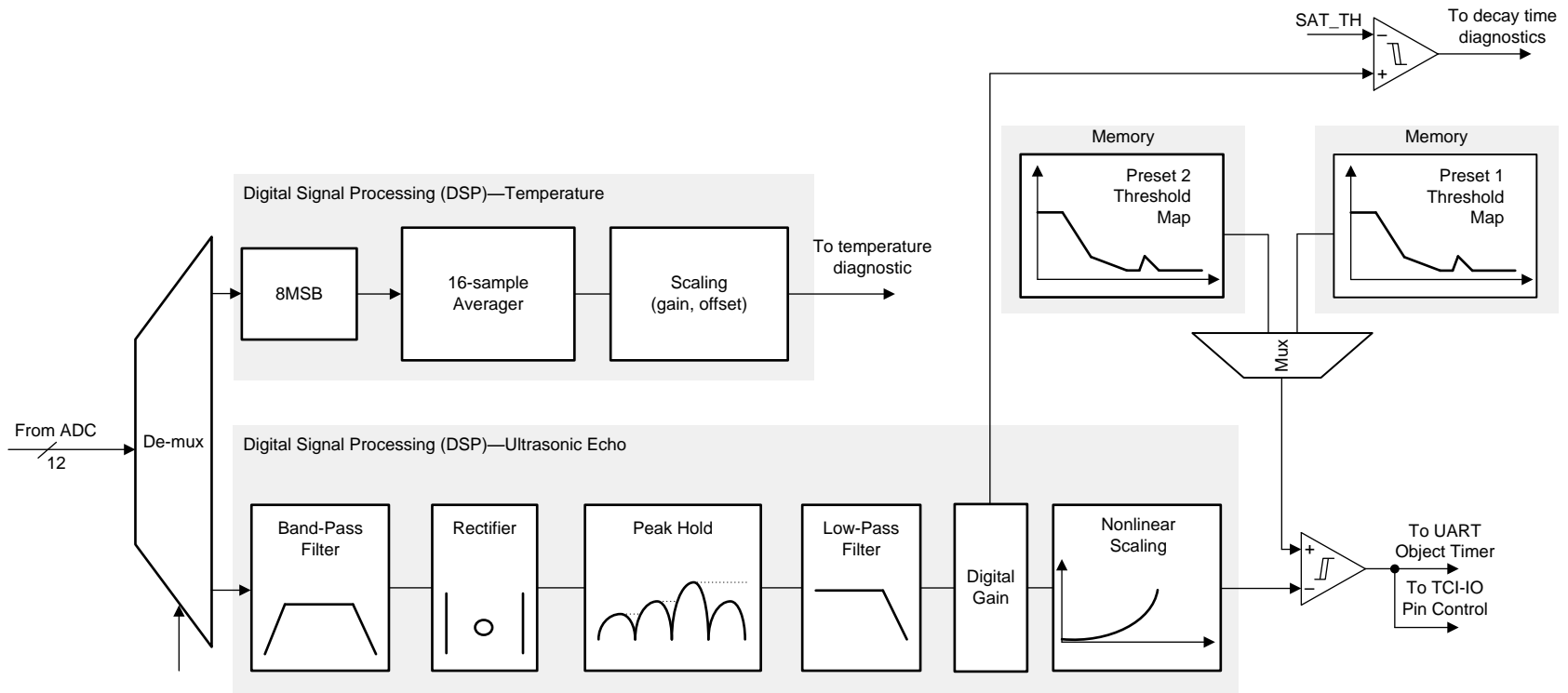
The band-pass filter is a second-order Butterworth IIR type filter. On power up, the PGA460 device calculates the coefficients and places them in the **BPF\_A2\_xSB**, **BPF\_A3\_xSB**, and **BPF\_B1\_xSB** registers. These registers can be overwritten by the user to reconfigure the filter. However, if the **FREQ** or **BPF\_BW** bit is changed, the coefficient calculation sequence is rerun and the device rewrites these registers. In case the **FREQ\_SHIFT** bit is set to 1 (80- to 480-kHz driving frequency range), the band-pass filter coefficients are not calculated automatically by the PGA460 device. In this case the MCU is required to write these values through the UART or USART interface.

### 7.3.4.2 Ultrasonic Echo—Rectifier, Peak Hold, Low-Pass Filter, and Data Selection

The rectifier, peak extractor, and low-pass filter DSP blocks demodulate the echo signal while outputting a base-band representation to be compared against the programmed thresholds. These blocks are defined as:

**Rectifier** This block outputs the absolute value of the input signal since the input signal can be positive and negative in amplitude.

**Peak hold** This block holds the peak value of the rectified signal for a specific amount of time required for the low-pass filter to detect the peak amplitude of the signal.

**Low-pass filter (LPF)** This block removes any noise artifacts from the echo signal. The LPF is realized as a first-order IIR type filter. The user can set the cutoff frequency by setting the **LPF\_CO** bit in **CURR\_LIM\_P2** register from 1 kHz to 4 kHz with a step of 1 kHz.

On power up the PGA460 device calculates the values of the filter coefficients and places them in the **LPF\_A2\_xSB** and **LPF\_B1\_xSB** registers, respectively. The user can overwrite the values in these registers and reconfigure the filter. In this case, the PGA460 device does not take any action. However, if the **LPF\_CO** bit is changed, the coefficient calculation sequence must be rerun and the device repopulates these registers.

### 7.3.4.3 Ultrasonic Echo—Nonlinear Scaling

The nonlinear scaling block in the DSP data path provides exponential scaling (digital nonlinear amplification) for the echo signal to achieve a higher SNR. This feature is useful for detecting long distance object where the amplitude of the echo signal is very attenuated and close to the noise floor.

The nonlinear scaling block performs the following algorithm:

```

if (t < Time_Offset)
    Output = Input;
else
    Output = (Input - Noise_Level)Scale_Exponent;
  
```

where

- **t** is the current record time.
- **Time\_Offset** is set by the **SCALE\_N** parameter and is used to select one of the time points corresponding to threshold points, **TH9**, **TH10**, **TH11**, or **TH12** defined in the [Ultrasonic Echo—Threshold Data Assignment](#) section.
- **Scale\_Exponent** is the nonlinear exponent (1.5 or 2) and defined by the **SCALE\_K** bit.
- **Noise\_Level** is the user-set noise level between 0 and 31 in 1 LSB step and defined by the **NOISE\_LVL** bit. (3)

The **SCALE\_N**, **SCALE\_K**, and **NOISE\_LVL** bits are EEPROM parameters in the **DSP\_SCALE** register.

注

The nonlinear scaling block can be applied to Preset1 and Preset2.

### 7.3.4.4 Ultrasonic Echo—Threshold Data Assignment

The PGA460 threshold assignments are organized in two presets: Preset1 and Preset2. Both of these presets have an independent memory map for threshold segment allocation. The PGA460 device supports up to 12 threshold segments for each preset defined by the threshold segment points (TSP) in the P1\_THR\_[0:15] registers for Preset1 and P2\_THR\_[0:15] registers for Preset2.

图 8 shows an example of a threshold assignment.



图 8. Threshold Assignment Example

As shown in 图 8, each TSP is described in the (time, level) format while  $P_x$  is the preset number (P1 for Preset1, P2 for Preset2). Additionally, only the initial segment time parameter (TH\_Px\_T1) value is expressed in terms of absolute time, while all following TSP times (TH\_Px\_Tx parameters) are expressed as a delta time between the absolute time value of the previous TSP and the absolute time value of the current TSP. The level values of each TSP (TH\_Px\_Lx parameters) are all expressed in an absolute LSB-level value and are unrelated from each other. The TSP level threshold value at any given time moment is determined by the PGA460 device as a linear interpolation function between the two neighboring threshold segment points

As shown in 图 8, the initial segment has a constant threshold value determined by the TH\_Px\_L1 parameter until reaching the start of the first segment and also the 12th segment will have a constant threshold value determined by the TH\_Px\_L12 parameter until reaching the end of record time defined by the Px\_REC parameter.

The TH\_Px\_L1 through TH\_Px\_L8 threshold parameters are 5-bits wide and the TH\_Px\_L9 through TH\_Px\_L12 parameters are 8-bits wide. These sizes help save memory space and at the same time allow higher resolution for long-range detection of weak echo signals in presence of noise while keeping the range constant across all TSPs. Because the TH\_Px\_L1 through TH\_Px\_L8 resolution is an 8 LSB, a threshold offset is defined to allow finer adjustment of the threshold map for short-range detection.

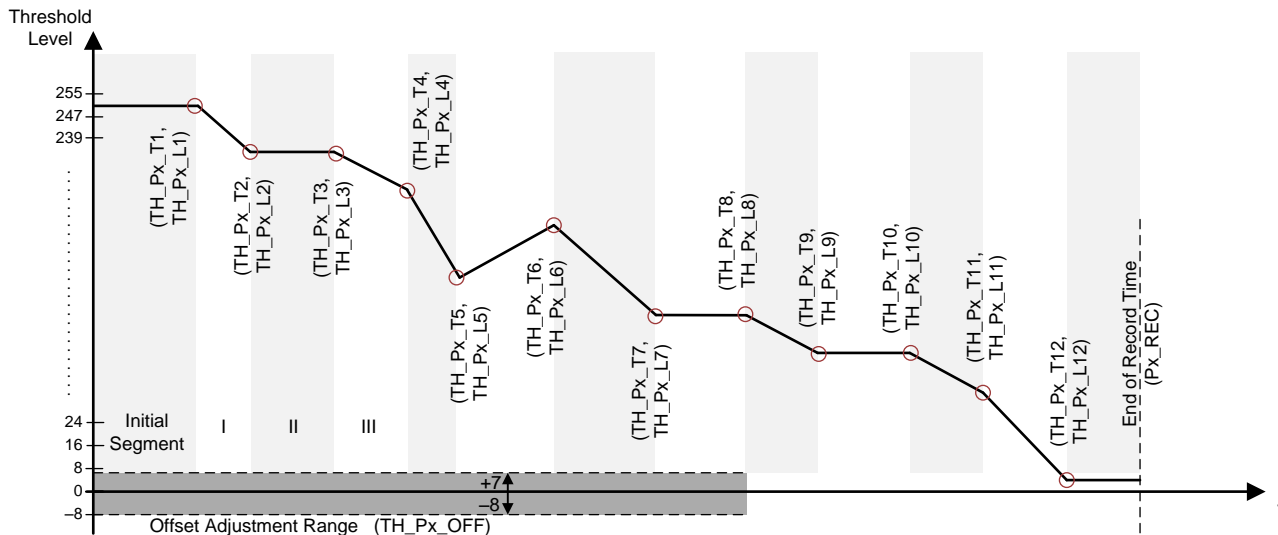
## 注

- All calculated values of TSP after adding offset, if negative, are clamped to 0 before linear interpolation which causes the slope of threshold curve to deviate from expected value.
- Both Preset1 and Preset2 threshold map parameters are protected by a CRC calculation algorithm (公式 6).
- At power up or wakeup from low power mode, all threshold registers (Px\_THR\_XX) and threshold CRC register (THR\_CRC) are not initialized to the default value which causes a CRC error and sets THR\_CRC\_ERR bit to 1. This occurrence indicates to the MCU that the configuration is not loaded properly. Writing to threshold registers reruns CRC calculation and updates the error bit.

### 7.3.4.5 Digital Gain

A digital gain feature after the low-pass filtering is implemented to improve the SNR of the received echo without lowering the threshold values. Because this gain is applied after the band-pass and low-pass filtering, the digital gain does not amplify the out of band noise. This gain feature can help in suppressing false detection such as ground reflection and detecting farther objects with more accuracy.

Two sets of digital gain ranges are available: short range (SR) and long range (LR). The SR and LR gain levels are set using the Px\_DIG\_GAIN\_SR and Px\_DIG\_GAIN\_LR parameters, respectively, in the Px\_GAIN\_CTRL register independently for Preset1 and Preset2. The LR gain is applied starting from the threshold level point set by Px\_DIG\_GAIN\_LR\_ST parameter to the end of the record period. The SR gain is applied from time zero to the start of the selected LR-threshold level point.

To prevent false detection of an echo at the point in time where the digital gain is applied, the defined thresholds are also changed as shown in the example plot in 图 9. Here, the LR gain is applied starting from the threshold level point 9. If the LR gain is different than the SR gain at threshold level point 8, the threshold level 8 is multiplied by the ratio between the LR gain and SR gain ( $DIG\_GAIN\_LR/DIG\_GAIN\_SR$ ) 1  $\mu$ s after the end of the SR threshold level 9 point. Although this creates a discontinuity in the threshold level, the object detection is not affected (a false threshold crossing is prevented) because the echo signal is also scaled by the same gain ratio. After this point, the threshold level is changed to the next set threshold level (point 9 in example below) using a linear interpolation scheme. The threshold levels should be adjusted by taking the digital gain and the ratio between the LR and SR gains into account.



图 9. Example of DIG\_GAIN\_LR\_ST = [00] TH9

### 7.3.5 System Diagnostics

The system diagnostics in the PGA460 device help characterize the transducer element during the burst itself and determine the status of the overall system. By using the provided information the system should be able to detect transducer failure, driver-circuit failure (transformer failure if used), environmental effects on the system (such as ice, dirt, snow), objects compromising the transducer operation (such as pressure applied to the transducer), and others.

Three implemented system diagnostics are available in the PGA460 device that provide information which can be used in detecting system flaws. These diagnostics are described as follows:

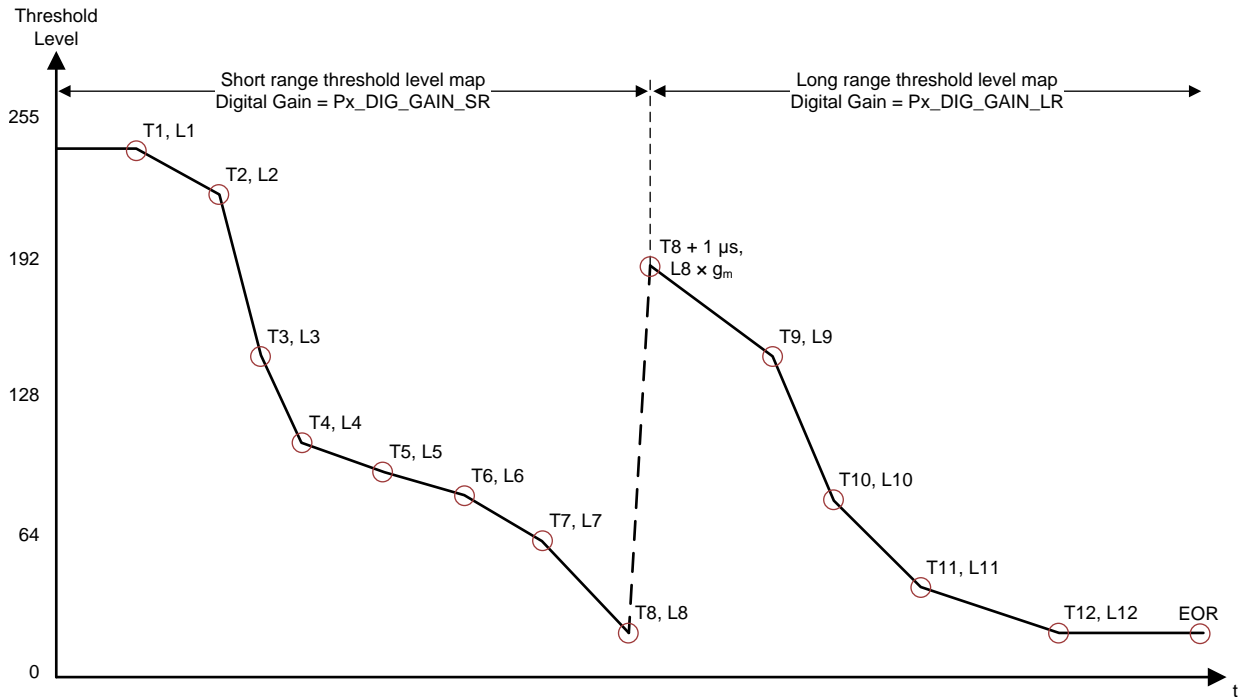
**Voltage diagnostic measurement** The voltage diagnostic feature is obtained by monitoring the current flowing through the INP pin only when a BURST/LISTEN run command is executed. The transducer excitation voltage at the particular burst frequency results in a current at INP pin that is compared to a reference current with a current comparator as shown in 图 10. If the excitation current exceeds the threshold level set using the FVOLT\_ERR\_TH in FVOLT\_DEC register, the current comparator output goes high which implies a normal burst with the desired level of excitation voltage. The measurement starts approximately 50 μs after the burst stage is started and ends at the end of the burst stage. The result of this diagnostic measurement is reported in the status frames of the IO time-command or the UART interface as described in the [Interface Description](#) section.



图 10. Block Diagram for Voltage Diagnostic

$$V_{(\text{diag})} \cong 3.25E^{-03} \times \text{FVOLT\_ERR\_TH}[2:0] \times \left( R_{(\text{INP})} + \frac{1}{6.28 \times f_{(\text{burst})} \times C_{(\text{INP})}} \right)$$

where

- FVOLT\_ERR\_TH[2:0] corresponds to 1 for 000b to 8 for 111b.
- $f_{\text{burst}}$  is the burst frequency in kilohertz.
- $C_{\text{INP}}$  is the input capacitance on the INP pin.
- $R_{\text{INP}}$  is an optional resistor (See 图 136) used for EMI and ESD robustness.

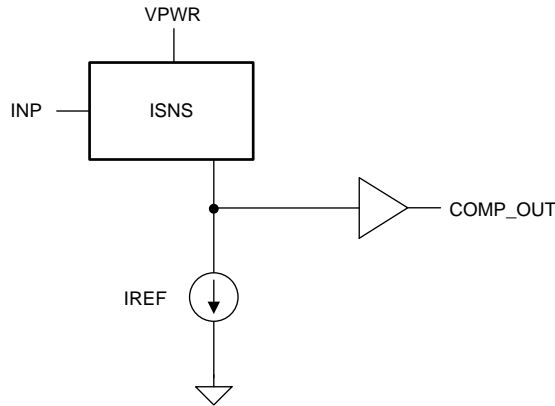
(4)

注

Prior to bursting, the comparator output is expected to be low. In the event that the output is stuck high, the condition is detected and the diagnostic fail flag is set

**Transducer frequency measurement** During the decay stage of the record interval a frequency measurement on the transducer node is performed to validate the performance and proper tuning of the transformer and transducer matching.

To measure the transducer frequency, a start parameter, FDIAG\_START, and a window length parameter, FDIAG\_LEN, are defined in EEPROM memory. The start parameter, FDIAG\_START, defines the time when the frequency measurement starts relative to the end of the burst time. The diagnostic window length parameter, FDIAG\_LEN, sets the time width of the diagnostic window in terms of signal periods captured. A brief example of parameter configuration can be explained:

1. Assume FDIAG\_START = 2 and FDIAG\_LEN = 1. Referring to the [Register Maps](#) section, the start time of these EEPROM parameters is determined to be 200  $\mu\text{s}$  after the burst is completed and window length of 3 signal periods. Assuming an operating frequency of 58 kHz, the signal period is 17.24  $\mu\text{s}$  and therefore the diagnostic ends at 200  $\mu\text{s}$  + 3  $\times$  17.24  $\mu\text{s}$  = 251.72  $\mu\text{s}$  after the burst is complete.
2. The frequency information captured in the measurement window is averaged and expressed as a 500-ns time based counter value. The signal frequency can be calculated using [公式 5](#).

$$f = 1 / (\text{FDIAG\_VAL} \times 500\text{e-}09)$$

where

- FDIAG\_VAL is a value that can be extracted using any of the device interfaces. (5)
3. If the specified number of objects are detected before a frequency diagnostic measurement completes, no frequency measurement results are saved. This can be managed by setting the previously defined diagnostic parameters and threshold settings for near-object detection.

An additional frequency error feature is implemented in the PGA460 device to signify that the

measured transducer frequency is outside of the limits set by the FDIAG\_ERR\_TH threshold parameter. The result of this feature is reported in the status frames of the IO time-command or the UART interface. For more information on reporting the transducer frequency error, see the [Interface Description](#) section.

**Decay-period time capture** During the decay stage of the record interval a transducer decay time measurement is performed to verify correct operation of the transducer. This diagnostic in combination with the transducer frequency measurement are commonly used in ultrasonic systems to detect external blockage of the ultrasonic transducer.

The decay period time is measured at the output of the digital data path. The measurement starts at the same time when the burst stage is completed and the decay period is measured as long as the echo level is higher than a saturation threshold level defined in the EEPROM by the SAT\_TH parameter. The provided result can be extracted by using any of the PGA460 interfaces, while the value is expressed in 16- $\mu$ s time increments. If the decay time measured greater than 4 ms, the value extracted will read 0xFF.

**Noise level measurement** An additional system diagnostic implemented in the PGA460 device is the noise-level measurement diagnostic. The purpose of this function is to evaluate the surrounding noise generated by other ultrasonic systems nearby to determine disturbances and also evaluate the noise floor level when far distance objects are being detected.



During the noise-level measurement, the PGA460 device executes the LISTEN ONLY (Preset2) command (see the [Interface Description](#) section for details of the command) where no burst is performed but only a record interval is started and lasts 8.192 ms. During this record interval, the data collected at the output of the digital data path is averaged into two groups each containing 4096 samples. The final noise level is measured by performing the noise-level measurement function is the higher averaged value of the two groups. This value is reported as the final noise-level measurement.

---

**注**

The nonlinear scaling block is always disabled (scale factor EEPROM by setting the SCALE\_K bit 0 and the NOISE\_LVL bit to 0) during the noise-level measurement process.

---

 11 shows the system diagnostics implemented in the PGA460 device as a full object-detection record cycle example. The numbers 1, 2, and 3 in  11 show voltage diagnostic, transducer frequency, and decay-period measurement, respectively.

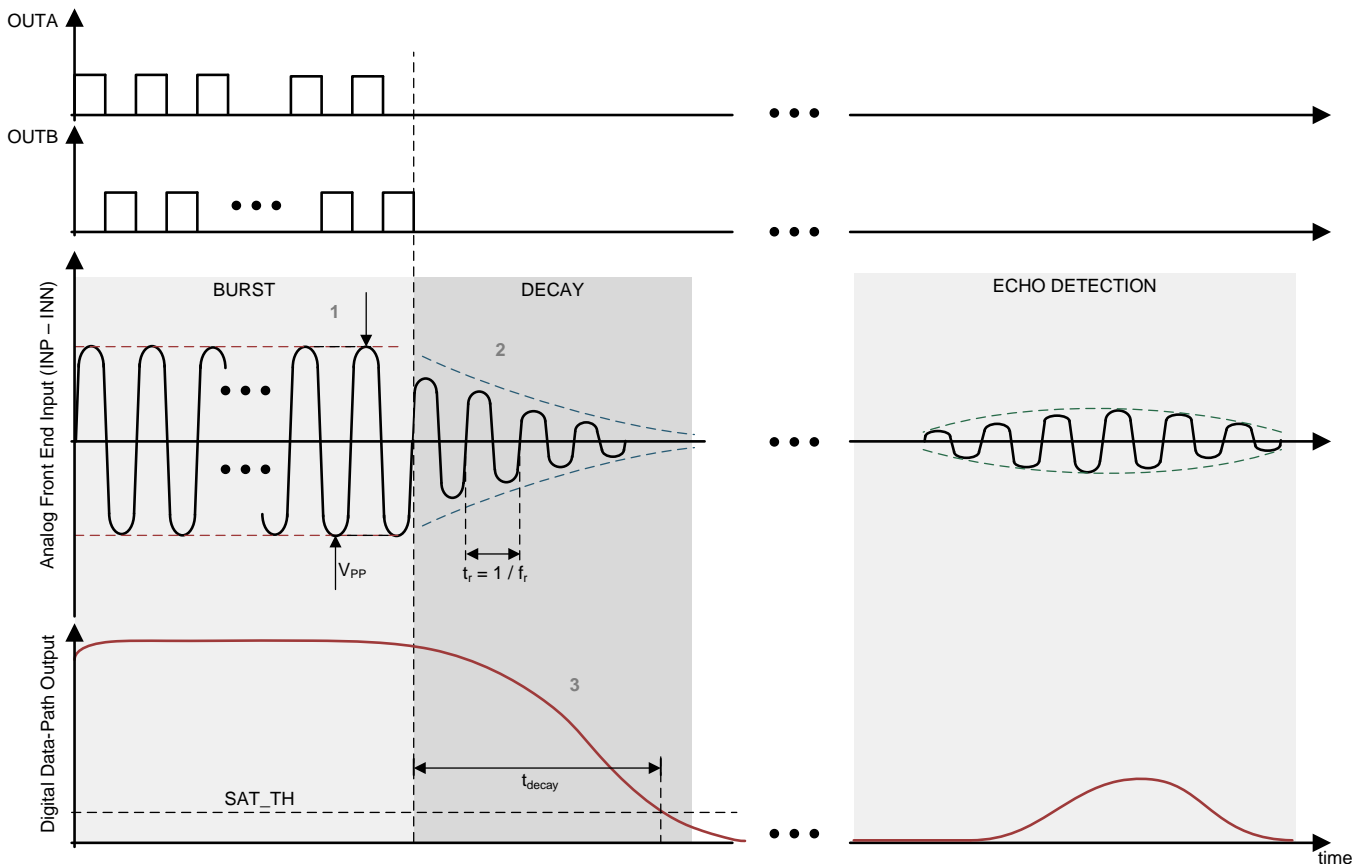
**图 11. Systems Diagnostics Example**

### 7.3.5.1 Device Internal Diagnostics

The PGA460 device also offers Internal diagnostics against overvoltage (OV), undervoltage (UV), overcurrent (OC), and thermal shutdown.

The OV, UV, and thermal shutdown conditions are reported through the status bits in the DEV\_STAT1 register. The OC protection is implemented on the device integrated regulators; however, the effect of this protection is not reported. For proper operation and to avoid false triggering, all electrical diagnostics are passed through a 25- $\mu$ s deglitch while the thermal shutdown diagnostic is passed through a 50- $\mu$ s deglitch before being reported.

The OV and UV protection thresholds for the internal regulators are listed in the [Specifications](#) section. When a fault is detected, the corresponding status bit is set and it is cleared upon interface read (clear-on-read type). The input device supply on the VPWR pin defines a fixed UV-threshold level and adjustable OV-threshold level (VPWR\_OV\_TH) that keeps the device active while disabling the output driver. This feature allows control of power dissipation at high voltage inputs without damaging the driver. When a VPWR\_UV flag is detected, any presently running TCI command finish and no new TCI commands are executed until the undervoltage condition is removed. This feature is not applicable to USART communication irrespective of the pins (RXD, TXD, or IO)

The thermal shutdown protection diagnostic monitors the temperature of the FETs of the low-side driver. In case of a thermal shutdown event, the PGA460 device disables the output drivers and re-enables them when the thermal shutdown condition is removed. After thermal shutdown recovery, the thermal shutdown status bit is set to notify the user of the action taken.

#### 注

If the voltage on the VPWR pin is less than 5 V, the performance of the device is not ensured as the digital core might reset. Any settings stored in the volatile memory section of the register map will be cleared.



### 7.3.6 Interface Description

The PGA460 device is equipped with two communication interfaces, each with a designated pin. The time-command interface is connected to the IO pin which is an open-drain output structure with an internal 10-k $\Omega$  pullup resistor capable of communicating at battery level voltage. The asynchronous UART interface can communicate on the IO pin and is also connected to the RXD and TXD pins. A third Interface option is to use the synchronous USART interface which is available only at the RXD and TXD pins. This communication uses SCLK pin for a serial clock input and is the fastest data-rate mode. USART communication on RXD and TXD pins is available at a 3.3-V or 5-V CMOS level depending on the configured IOREG voltage as described in the [TEST Pin Functionality](#) section.

#### 注

Because the system is unlikely to simultaneously use both the time-command interface and the UART interface, the PGA460 device can disable the IO pin transceiver to preserve power. To do so, the IO\_IF\_SEL bit must be 0, and the IO\_DIS bit must be 1 which immediately disables the IO pin transceiver upon which communication is only possible through the RXD and TXD pins. Setting the IO\_DIS bit back to 0 does not re-enable the IO interface. If the IO\_DIS bit was set unintentionally, the device can recover the IO interface (reset the IO\_DIS bit to 0) upon power-cycle; however, when the value of this bit is programmed in the EEPROM, the PGA460 device always follows the EEPROM-programmed value on power up.

#### 7.3.6.1 Time-Command Interface

The time-command interface is the communication interface connected on the IO pin. The default state for the IO pin when the interface is idle is HIGH (pulled up to VPWR). The pin communication is bi-directional, where upon receiving a command, the PGA460 device is actively driving the IO pin and providing a response by changing the state of the IO pin. If the time-command interface remains stuck while transmitting a command or data for a particular command that is either LOW or HIGH for more than 15 ms, then the PGA460 communication resets and is expected to receive a new command transmission from the master device.

The time-command interface is specified by five time commands, where four are classified as run commands and one CONFIGURATION/STATUS command. Logic 0 is transmitted by pulling the IO pin low for a time duration of  $t_{\text{BIT0\_TCI}}$  and logic 1 is transmitted by pulling the IO pin low for time duration of  $t_{\text{BIT1\_TCI}}$  as defined in the [Specifications](#) section. [图 12](#) and [图 13](#) respectively show the general timing diagram for device time commands and for logic bit timing. The  $t_{\text{(DT\_TCI)}}$  dead-time is defined for the PGA460 device to process the received command and change the IO pin state from input to output.



图 12. Time-Command Interface Command Timing



图 13. Time-Command Interface Bit Timing

#### 7.3.6.1.1 RUN Commands

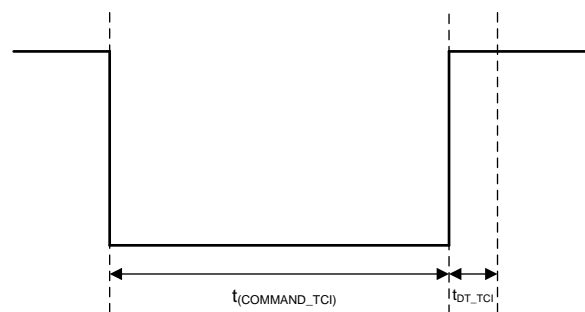
The run commands are used for device run-time operation and are most commonly used during the normal operation cycle of the PGA460 device. These device commands are specified by pulling the IO pull low for a specified period of time as defined in the [Specifications](#) section. The following are classified as run commands:

**Burst/Listen (Preset1)** The device sends an ultrasonic burst using the P1\_PULSE number of pulses while using the CURR\_LIM1 current-limit setting and runs an object-detection record interval defined by the value of the P1\_REC time length. During the process of object detection, the P1\_THR\_xx threshold map is used for signal comparison. The nonlinear scaling DSP function is available for use with this command.

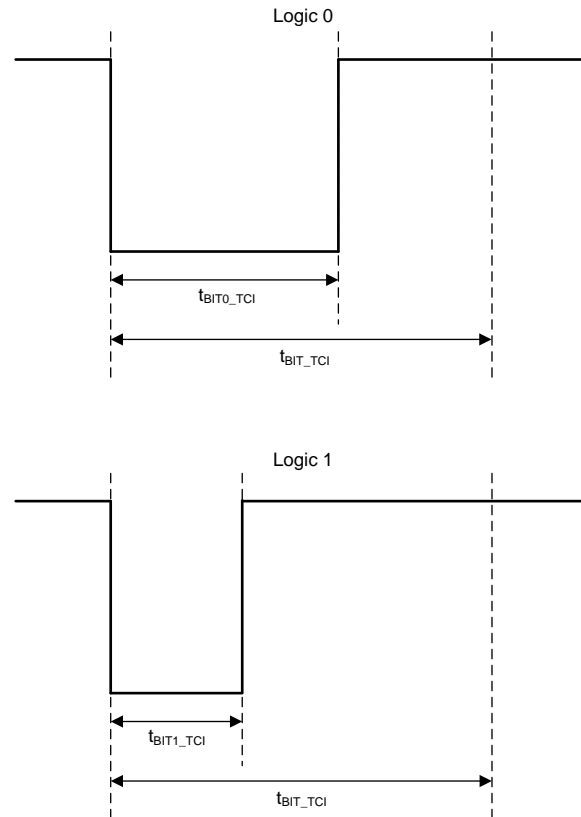
**Burst/Listen (Preset2)** The device sends an ultrasonic burst using the P2\_PULSE number of pulses while using the CURR\_LIM2 current-limit setting and runs an object-detection record interval defined by the value of the P2\_REC time length. During the process of object detection, the P2\_THR\_xx threshold map is used for signal comparison. The nonlinear scaling DSP function is available for use with this command.

**Listen Only (Preset1)** The device does not send an ultrasonic burst, however, and only runs an object-detection record interval defined by the value of the P1\_REC time length. During the process of object detection, the P1\_THR\_xx threshold map is used for signal comparison. The nonlinear scaling DSP function is available for use with this command.

**Listen Only (Preset2)** The device does not send an ultrasonic burst, however, but only runs an object-detection record interval defined by the value of the P2\_REC time length. During the process of object detection, the P2\_THR\_xx threshold map is used for signal comparison. The nonlinear scaling DSP function is available for use with this command.

图 14 shows the process of the communication of the IO pin run command.



图 14. Time-Command Interface RUN Command Execution

The status field of the PGA460 device is embedded in the run command and provided back to the master controller by extending the dead-time on the IO bus. The dead-time can be further extended for up to  $3 \times t_{(DT\_TCI)}$  which signifies three status bits, STAT[1:3]. Each status bit has an assigned diagnostic and a priority as listed in 表 1.

表 1. Time-Command Interface Status Bits Description

STATUS BIT	PRIORITY	DESCRIPTION
STAT 1	1, low	Threshold settings uninitialized error
STAT 2	2	Frequency diagnostics error
		Voltage diagnostic error
STAT 3	3, high	Power-up auto EEPROM CRC error
		User triggered EEPROM download CRC error

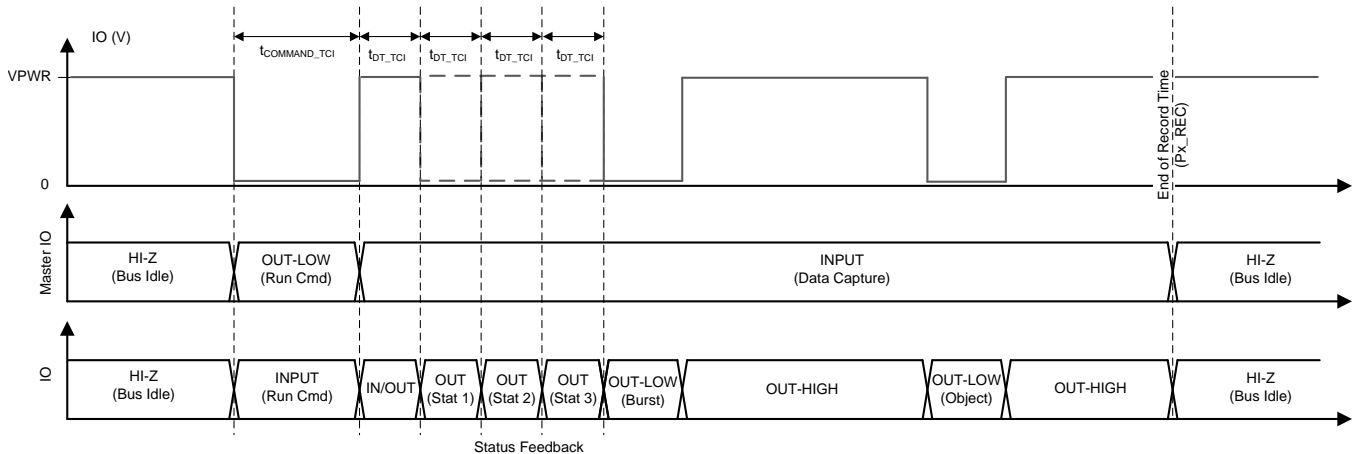
As listed in 表 1, the STAT3 bit has the highest priority. When a STAT3 error condition is present, then the dead-time is further extended by  $3 \times t_{(DT\_TCI)}$ . In this case, if any STAT2 or STAT1 error conditions are also present, these conditions are overruled by the higher priority of STAT3 error conditions. In a similar way, a STAT1 condition is overruled by a STAT2 error condition in which case the dead-time is further extended by  $2 \times t_{(DT\_TCI)}$ . When all STAT3 and STAT2 error conditions have cleared, a STAT1 condition further extends the dead-time by an additional  $t_{(DT\_TCI)}$ .

The functions of the status bits can be explained as follows:

- STAT 1** This status bit is set to 1 when both preset threshold register groups are uninitialized. Any run command received over the TCI communications channel is not executed until either preset threshold register group is programmed.
- STAT 2** This status bit is set to 1 when any of the following occurs:
- If the measured frequency value as described in the [System Diagnostics](#) section for frequency diagnostics is higher or lower than the delta value defined by the FDIAG\_ERR\_TH parameter in the EEPROM memory (this is consider to be a frequency diagnostic error).
  - If the measured voltage value as described in the [System Diagnostics](#) section for transducer voltage measurement is lower than the level provided by the FVOLT\_ERR\_TH parameter in EEPROM memory.
- STAT 3** Any run command received over the TCI communications channel is not executed until the EE CRC error is fixed.
- The user can write to any EEPROM-mapped register to clear the error.
- The user must reprogram the EEPROM to prevent the error upon another automatically or manually triggered EEPROM download operation.

PGA460

ZHCSGA0B – APRIL 2017 – REVISED JANUARY 2019

www.ti.com.cn

When the device receives a run command, the IO pin is actively driven by the PGA460 device depending on the final DSP output to indicate object detection. If, at any time, the processed echo signal exceeds the threshold at that time, the IO pin is pulled low (GND, strong pulldown) otherwise the IO pin is pulled up by the internal 10-kΩ (weak pullup) resistor. When the record time reaches the end of the record defined by the Px\_REC parameters, the IO pin is released (pulled up as an input) and the device is ready for a next command. 图 15 shows the object detection functionality of the IO pin. The device pulls the IO pin low during the burst and then releases it to provide a reference for the recording time-frame for the MCU. Knowing the time of reference, the duration of the programmed burst and following falling edges for each object detected, the master controller or MCU can calculate the object distance.



图 15. IO-Pin Object-Detection Signaling With Burst/Listen Time Command



图 16. IO-Pin Object-Detection Signaling With Listen-Only Time Command

The PGA460 device forces IO pin to go low after the  $t_{(DT\_TC)}$  time passes after receiving a run command for a minimum of 300  $\mu\text{s}$  which indicates start of the record period. This process occurs to provide the master controller a reference edge to start the time of flight measurement and also for PGA460 device to separate the response of the status (STAT) bits from the record cycle information. In general, the duration of burst for lower frequency range followed by ringing causes the AFE to saturate and pull the IO pin low for more than 300  $\mu\text{s}$ . For higher frequency burst or for listen-only command, or in situations where the saturation caused by the ultrasonic burst might not be a higher value than the assigned threshold, as shown in [图 16](#), the minimum pulse width is 300  $\mu\text{s}$ . With a certain filter and deglitch setting, a fake object can be detected directly after this 300- $\mu\text{s}$  period.

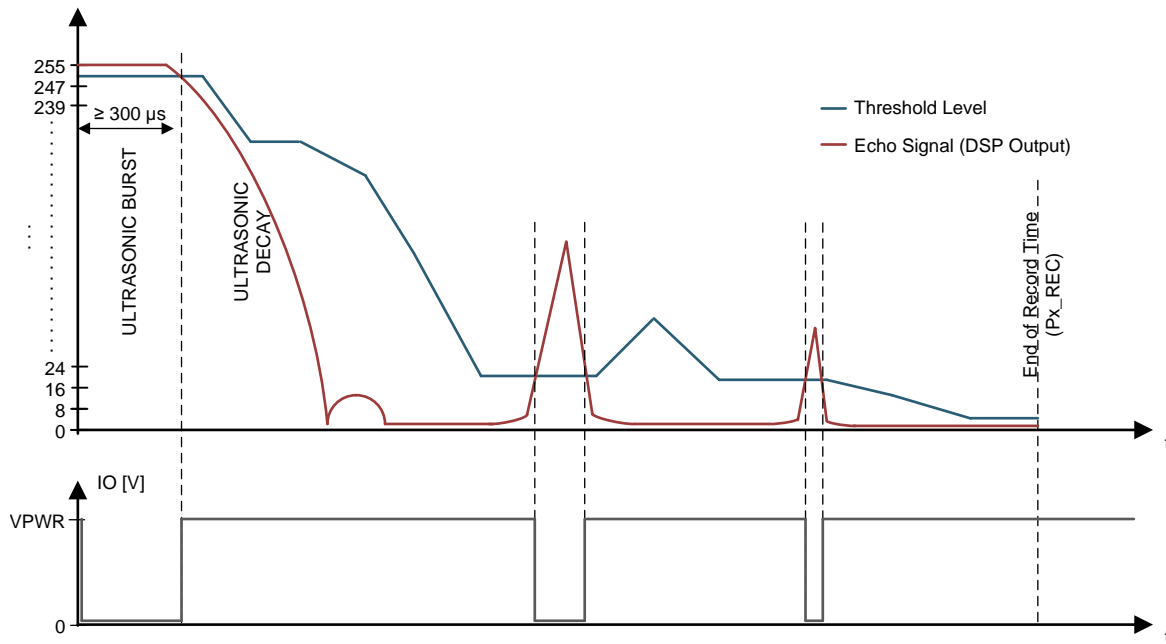
#### 7.3.6.1.2 CONFIGURATION/STATUS Command

The CONFIGURATION/STATUS command is used for the following:

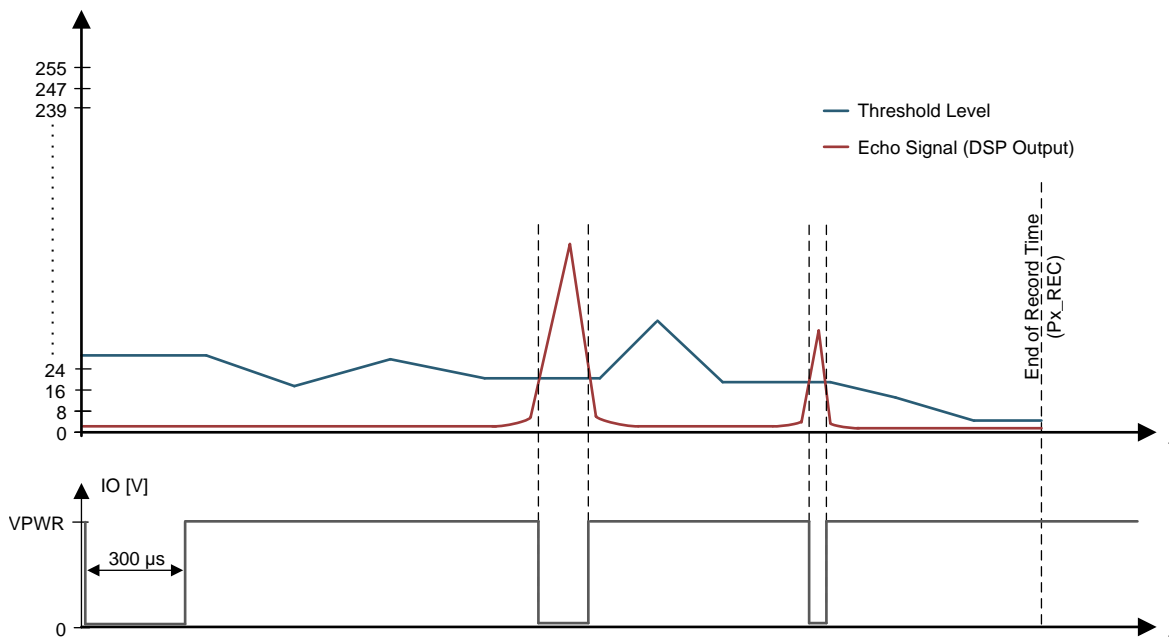
- PGA460 internal parameter configuration
- Time-varying gain and threshold setup
- EEPROM programing
- Diagnostics and temperature measurements
- Echo data-dump function

When the CONFIGURATION/STATUS command is issued, the remaining data is transferred by using bit-like communication where a logical 1 and logical 0 are encoded as shown in [图 13](#). [图 17](#) and [图 18](#) show a full-length CONFIGURATION/STATUS command.



图 17. Time-Command Interface CONFIGURATION/STATUS Command—Write



图 18. Time-Command Interface CONFIGURATION/STATUS Command—Read

As indicated, each CONFIGURATION/STATUS command frame consists of three data segments: subcommand field, data field, and frame checksum. The subcommands are defined and ordered by a 4-bit index field, where each subcommand can have a different data length in the data segment of the frame. 表 2 lists all PGA460 subcommands ordered according to their respective index.

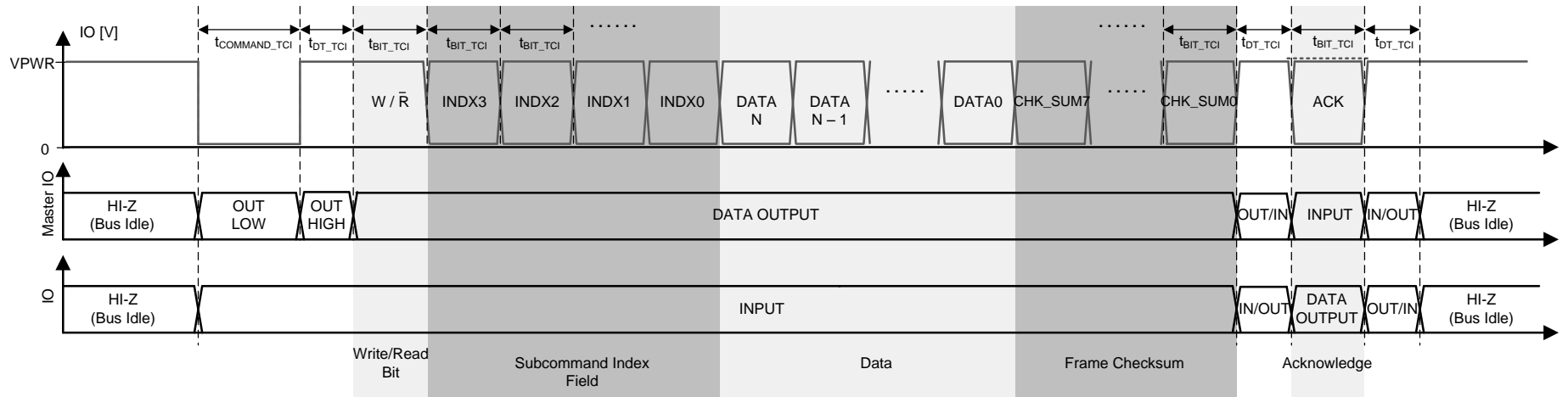
**表 2. Time-Command Interface Subcommand Description<sup>(1)</sup>**

INDEX	DESCRIPTION	DATA LENGTH (BITS)		ACCESS	EE
0	Temperature value	8		R	N
1	Transducer frequency diagnostic value	8	24	R	N
	Decay period time diagnostic value	8			
	Noise level diagnostic value	8			
2	Driver frequency (FREQ)	8		R/W	Y
3	Number of burst pulses for Preset1 (P1_PULSE)	5	18	R/W	Y
	Number of burst pulses for Preset2 (P2_PULSE)	5			
	Threshold comparator Deglitch (THR_CMP_DEG)	4			
	Burst pulses dead-time (PULSE_DT)	4			
4	Record time length for Preset1 (P1_REC)	4	8	R/W	Y
	Record time length for Preset2 (P2_REC)	4			
5	Threshold assignment for Preset1 (P1_THR_0 to P1_THR_15) <sup>(2)</sup>	124		R/W	N
6	Threshold assignment for Preset2 (P2_THR_0 to P2_THR_15) <sup>(2)</sup>	124		R/W	N
7	Band-pass filter bandwidth (BPF_BW)	2	42	R/W	Y
	Initial AFE gain (GAIN_INIT)	6			
	Low-pass filter cutoff frequency (LPF_CO)	2			
	Nonlinear scaling noise level (NOISE_LVL)	5			
	Nonlinear scaling exponent (SCALE_K)	1			
	Nonlinear scaling time offset (SCALE_N)	2			
	Temperature-scale gain (TEMP_GAIN)	4			
	Temperature-scale offset (TEMP_OFF)	4			
	P1 digital gain start threshold (P1_DIG_GAIN_LR_ST)	2			
	P1 digital long-range gain (P1_DIG_GAIN_LR)	3			
	P1 digital short-range gain (P1_DIG_GAIN_SR)	3			
	P2 digital gain start threshold (P2_DIG_GAIN_LR_ST)	2			
	P2 digital long-range gain (P2_DIG_GAIN_LR)	3			
P2 digital short-range gain (P2_DIG_GAIN_SR)	3				
8	Time-varying gain Assignment (TV_GAIN0 to TV_GAIN6)	56		R/W	Y
9	User-data memory (USER_1 to USER_20)	160		R/W	Y

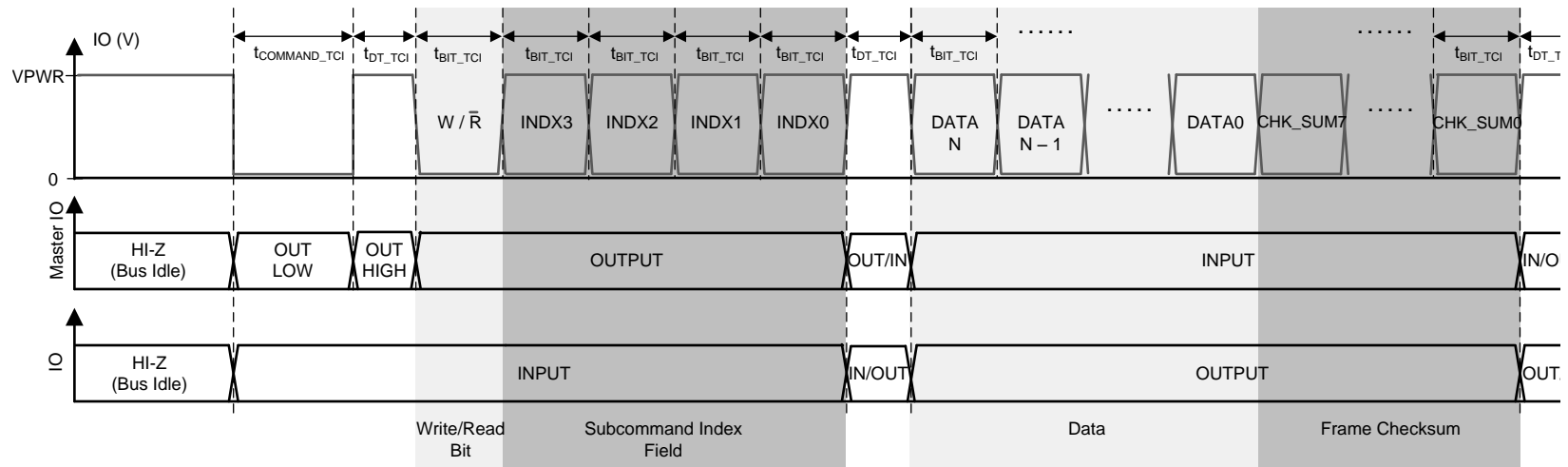
(1) The acronyms used in this table (for example, CURR\_LIM1) are the same as those used in the [Register Maps](#) section.

(2) Including the threshold level offset parameter (TH\_Px\_OFF).

**表 2. Time-Command Interface Subcommand Description<sup>(1)</sup> (接下页)**

INDEX	DESCRIPTION	DATA LENGTH (BITS)	ACCESS	EE
10	Frequency diagnostic window length (FDIAG_LEN)	4	R/W	Y
	Frequency diagnostic start time (FDIAG_START)	4		
	Frequency diagnostic error time threshold (FDIAG_ERR_TH)	3		
	Saturation diagnostic level (SAT_TH)	4		
	P1 nonlinear scaling (P1_NLS_EN)	1		
	P2 nonlinear scaling (P2_NLS_EN)	1		
	Supply overvoltage shutdown threshold (VPWR_OV_TH)	2		
	Sleep mode timer (LPM_TMR)	2		
	Voltage diagnostic threshold (FVOLT_ERR_TH)	3		
	AFE gain range (AFE_GAIN_RNG)	2		
	Low-power mode enable (LPM_EN)	1		
	Decouple time and temperature select (DECPL_TEMP_SEL)	1		
	Decouple time and temperature value (DECPL_T)	4		
	Disable current limit (DIS_CL)	1		
	Reserved	1		
	Driver current limit for Preset1 (CURR_LIM1)	6		
Driver current limit for Preset2 (CURR_LIM2)	6			
11	Echo data-dump enable (DATADUMP_EN)	1	R/W	N
	EEPROM programming password (0xD)	4		
	EEPROM programming successful (EE_PRGM_OK)	1		
	Reload EEPROM (EE_RLOAD)	1		
	Program EEPROM (EE_PRGM)	1		
12	Echo data-dump values <sup>(3)</sup>	1024	R	N
13	EEPROM user-bulk command (0x00 to 0x2B) <sup>(4)</sup>	352	R/W	Y
14	Reserved			
15	EEPROM CRC value (EE_CRC) THR_CRC value (THR_CC)	16	R	Y

(3) Echo dump memory is an array of 128 samples, 8 bits/sample.

(4) For index 13, byte 0x2B is read-only, when an index-13 write command is sent, the byte-2B data field will have no effect on the EE\_CRC value.

The frame checksum value is generated by both the master and slave devices, and is added after the data field, while calculated as the inverted eight bit sum with carry-over on all bits in the frame. The checksum calculation occurs byte-wise starting from the most-significant bit (MSB) which is the read-write (R/W) bit in the PGA460 write operation while for PGA460 read operation, this is the MSB of the data field. In cases where the number of bits on which the checksum field is calculated is not a multiple of eight, then the checksum operation pads trailing zeros until the closest multiple eight is achieved. Zero padding is only required for the checksum calculation. The zero-padded bits should not actually be transmitted over the IO-TCI interface.

The following example, is one example of a frame checksum calculation showing the PGA460 write operation of for subcommand Index 7 (42 data bits):

- Total number of bits for checksum generation: 1 R/W bit, 4 bits index value, 42 bits data values. The total number of bits is 47.
- Because the checksum is calculated byte-wise, 1 trailing zero is added to achieve 6 full bytes.
-  19 shows additional checksum calculation.

The following example, is a second example of a frame checksum calculation showing the PGA460 read operation of for subcommand index 8:

- Total number of bits for checksum generation by the PGA460 device: 56 bits data values + 8 command bits. The total number of bits is 64.
- The 8 command bits are equal to 4-zero bits + Index[3:0] = 8 command bits which is the first byte used in the checksum calculation.



- No trailing zeros added because the number of bits is already 56 or 7 bytes.
- 图 19 shows additional checksum calculation.



图 19. Checksum Calculation

In addition, when a PGA460 write operation is issued, the PGA460 device implements an acknowledgment bit response to signify a correct data transfer occurred. In this case, if the CONFIGURATION/STATUS command time period is not detected properly, the PGA460 device does issue an acknowledgment bit. If the CONFIGURATION/STATUS command-time period is detected properly but the checksum of the transferred frame is not correct, then the PGA460 device transmits a logical 0 acknowledgment. If the CONFIGURATION/STATUS command-time period is detected properly and the checksum value matches the correct checksum, then the PGA460 device transmits a logical 1 acknowledgment.

In the case of a bit-like communication (PGA460 actively serving CONFIGURATION/STATUS command) when the bit stream is interrupted with another time command (either RUN or CONFIGURATION), the PGA460 device decodes this event as a bit-timed event in which case the execution of the initial CONFIGURATION/STATUS command continues until either a time-out error event is reached or, in the case of a continuous data transfer, the PGA460 frame checksum invalidates the incorrectly transferred frame. In the case where the bit-stream is valid but is longer than expected, the PGA460 executes on the correctly transferred frame but ignores the rest of the bit-stream.

If, during PGA460 IDLE state, the time-command interface receives a time command with pulse duration outside the limits of any of the commands, this condition is ignored and the PGA460 device remains in the IDLE state until a valid time command is received. In this case, the PGA460 does not respond with a negative acknowledgment.

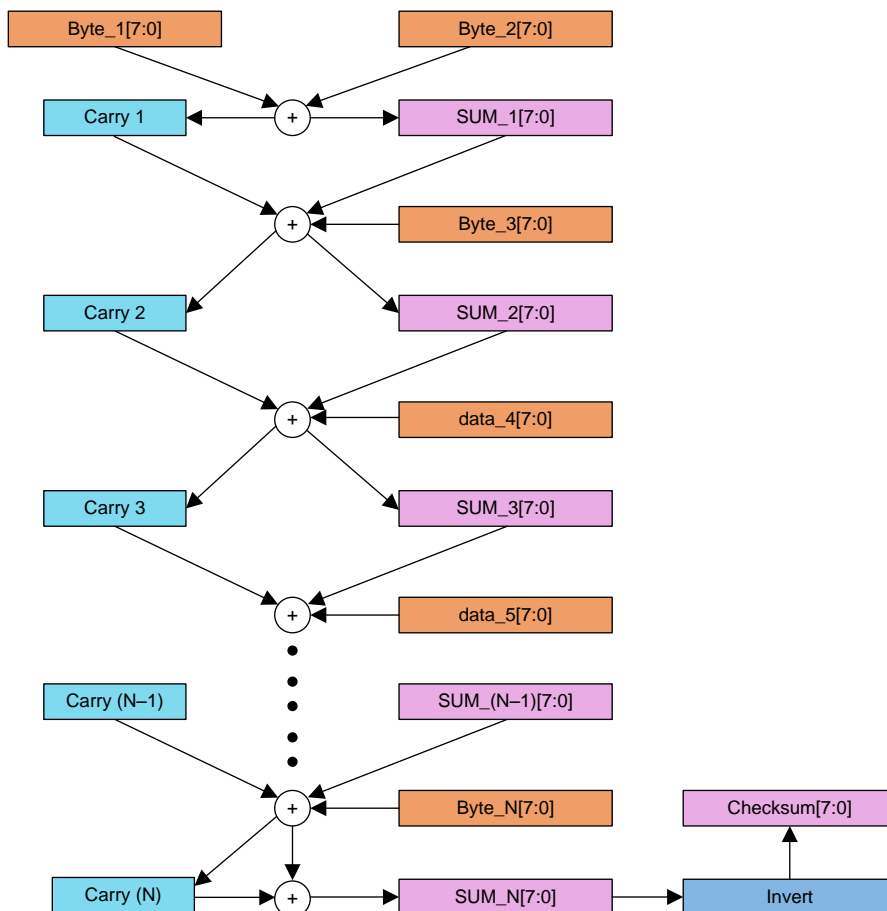
### 7.3.6.2 USART Interface

#### 7.3.6.2.1 USART Asynchronous Mode

The PGA460 device includes a USART digital communication interface. The main function of the USART is to enable writes to and reads from all addresses available for USART access. This function include access to most EEPROM-register and RAM-register memory locations on the PGA460 device. The USART asynchronous-mode (UART) digital communication is a master-slave communication link in which the PGA460 is a slave device only. The master device controls when the data transmission begins and ends. The slave device does not transmit data back to the master device until it is commanded to do so by the master device. A logic 1 value on the UART interface is defined as a recessive value (weak pullup on the RXD pin). A logic 0 value on the UART interface is defined as a dominant value (strong pulldown on the RXD pin).

The UART asynchronous-mode interface in PGA460 is designed for data-rates from 2400-bps to 115200-bps operation, where the data rate is automatically detected based on the sync field produced by the master controller. Other parameters related to the operation of the UART interface include:

- Baud rate from 2400 bps to 115 200 bps, auto-detected (as previously described)
- 8 data bits
- 1 start bit
- 2 stop bit
- No parity bit
- No flow control
- Interfield wait time (required for 1 stop bit)

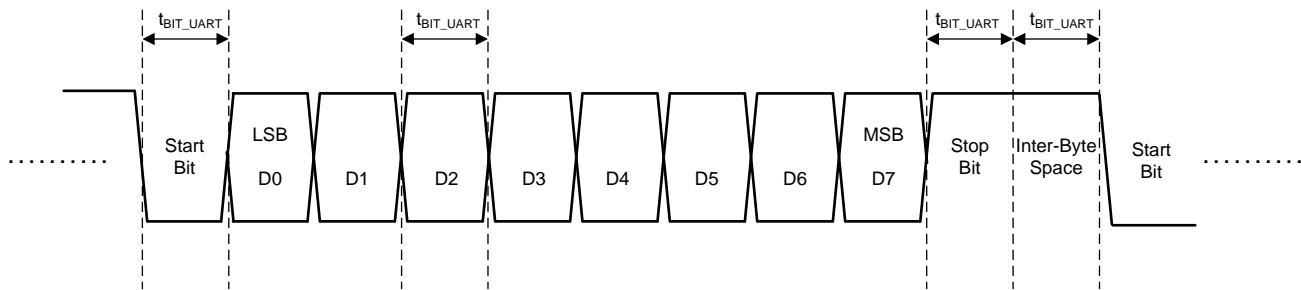

**图 20. USART Asynchronous Interface Bit Timing**

图 20 shows the bit timing for USART asynchronous mode. Both data and control are in little endian format. Data is transmitted through the UART interface in byte-sized packets. The first bit of the packet field is the start bit (dominant). The next 8 bits of the field are data bits to be processed by the UART receiver. The final bit in the field is the stop bit (recessive). The combined byte of information, and the start and stop bits make up an UART field. 图 21 shows the standard field structure for a UART interface field.

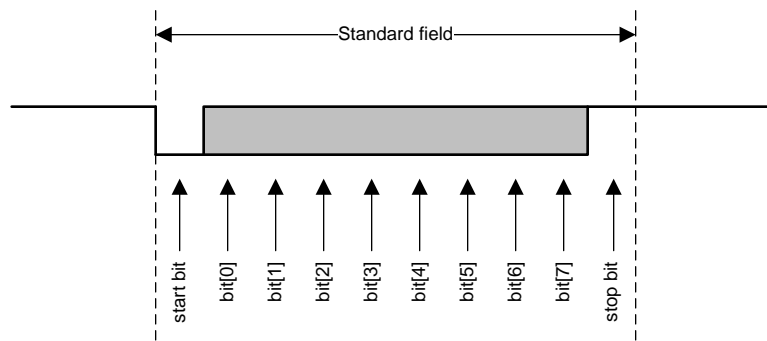

**图 21. UART Interface Packet Field**

A group of fields makes up a transmission frame. A transmission frame is composed of the fields required to complete one transmission operation on the UART interface. 图 22 shows the structure of a data transmission operation in a transmission frame.



图 22. UART Interface Transmission Frame

Each transmission frame must have a synchronization field and command field followed by a number of data fields. The sync field and command fields are always transmitted by the master device. The data fields can be transmitted either by the master or the slave depending on the command given in the command field. The command field determines the direction of travel of the data fields (master-to-slave or slave-to-master). The number of data fields transmitted is also determined by the command in the command field. The interfield wait time is 1-bit long and is required for the slave or the master to process data that has been received, or when data must change direction after the command field is sent and the slave device must transmit data back to the master device. Time must be allowed for the master and slave signal drivers to change direction. If the UART interface remains idle in either the logic 0 or logic 1 state for more than 15 ms, then the PGA460 communication resets and expects to receive a sync field as the next data transmission from the master device.

### 7.3.6.2.1.1 Sync Field

The sync field is the first field in every frame that is transmitted by the master. The sync field is used by the PGA460 device to confirm the correct baud rate of the frame that is sent by the master device. This bit width is used to accurately receive all subsequent fields transmitted by the master. The bit width is defined as the number of internal oscillator clock periods that make up an entire bit of data transmitted by the master. This bit width is measured by counting the number of slave oscillator clocks in the entire length of the sync field data, and then dividing by 8. 图 23 shows the format of the sync field.

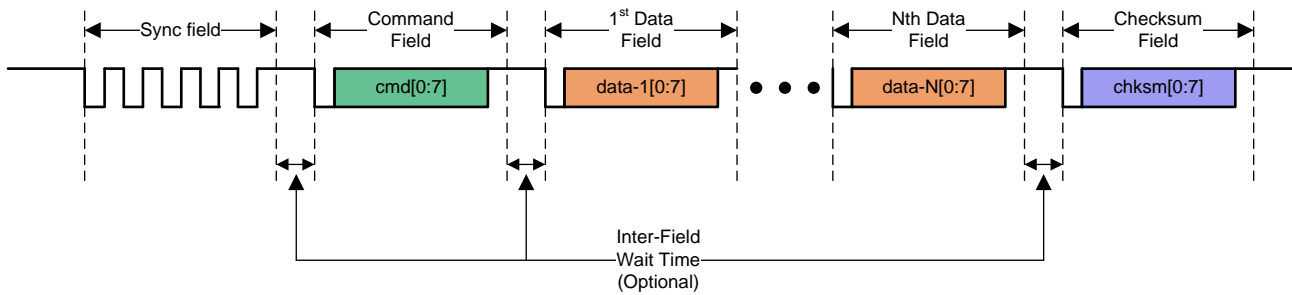

图 23. UART Sync Field

Consecutive sync-field bits are measured, including the start and stop bits, and compared to determine if a valid sync field is being transmitted to the PGA460 device is valid. If the difference in bit widths of any two consecutive sync field bits is greater than  $\pm 25\%$ , then the PGA460 device ignores the rest of the UART frame; essentially, the PGA460 device does not respond to the UART message.

### 7.3.6.2.1.2 Command Field

The command field is the second field in every frame sent by the master device. The command field contains instructions about what to do with and where to send the data that is transmitted to a particular PGA460 device. The command field can also instruct the PGA460 device to send data back to the master device during a read operation. The number of data fields to be transmitted is also determined by the command in the command field. [图 24](#) shows the format of the command field.

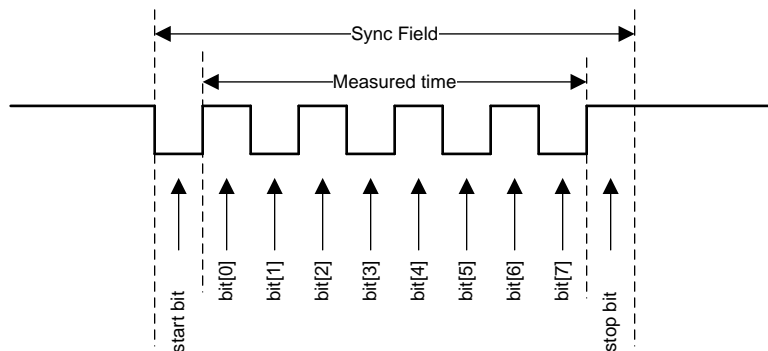
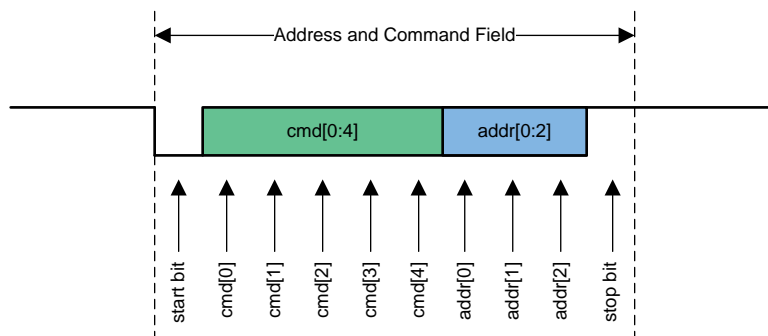

**图 24. UART Command Field**

In the PGA460 device, the last 3-bits of the command field are reserved for UART address information. The address information in the command field is compared to the UART\_ADDR parameter in the EEPROM memory where the UART address is programmed. Upon receiving the command field, the PGA460 device checks if the self-address matches the received address and if it matches, the device executes on the received command. If the address does not match, the device disregards the received frame. For improved communication efficiency, common broadcast commands are defined where the PGA460 device executes regardless of the address in the command field. For these commands and all UART commands, see [表 3](#).

#### 注

The factory preprogrammed address for the PGA460 device is 0.

### 7.3.6.2.1.3 Data Fields

After the master device has transmitted the command field in the transmission frame, zero or more data fields are transmitted to the PGA460 device (write operation) or to the master (read operation). The data fields can be raw memory data or a command related parameters. The format of the data is determined by the command in the command field. [图 25](#) shows the typical format of a data field.

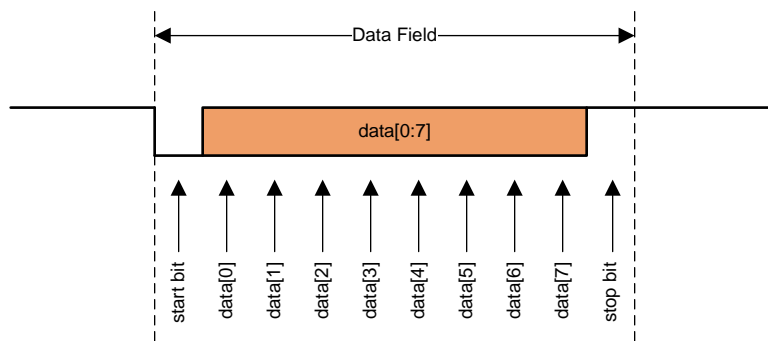

**图 25. UART Data Field**

#### 7.3.6.2.1.4 Checksum Field

A checksum field is transmitted as the last field of every UART frame. The checksum contains the value of the *inverted byte sum with carry* operation over all data fields and the command field (command field for master only). On a master-to-PGA460 transmission, the checksum field is calculated by the master device and checked by the PGA460 device. On a PGA460-to-master transmission, the PGA460 device generates the checksum and the master validates the integrity. The format of the checksum is identical to the data field and the procedure for calculating the checksum is explained in the [Time-Command Interface](#) section. Because the UART interface is a byte-based interface, no zero padding occurs in the process of calculating the checksum.

When the master device calculates the checksum field, the calculation occurs on the UART command field followed by all UART data fields that are transmitted as a part of the current communication frame. When the PGA460 device is calculating the checksum field, the calculation includes the diagnostic data field (see the [Diagnostic Field](#) section) followed by all UART data fields in the current frame. The sync field (0x55) is not included as part of the checksum calculation.

#### 7.3.6.2.1.5 PGA460 UART Commands

表 3 lists the PGA460 UART commands.

---

#### 注

In the case where any command is improperly received by the PGA460 device, for example a wrong command, wrong number of bytes, or wrong data byte values, then the PGA460 device does not execute on the received command or set the Error\_Status[4] bit described in the [Diagnostic Field](#) section.

---

**表 3. UART Interface Command List**

CMD[4:0]	COMMAND NAME	PGA460 RESPONSE	M-TO-S DATA BYTES	MASTER-TO-SLAVE DATA BYTES DESCRIPTION	S-TO-M DATA BYTES	SLAVE-TO-MASTER DATA BYTES DESCRIPTION
<b>SINGLE ADDRESS</b>						
0	Burst and listen (Preset1)	No	1	Byte1: N - Number of objects to be detected (valid range is from 1 to 8)	0	
1	Burst and listen (Preset2)	No	1		0	
2	Listen only (Preset1)	No	1		0	
3	Listen only (Preset2)	No	1		0	
4	Temperature and noise-level measurement	No	1	Byte1: 0 - Temperature measurement 1 - Noise Measurement 2–255 - Not used	0	
5	Ultrasonic measurement result <sup>(1)(2)</sup>	Yes	0		4 × N	Byte1–Byte2: Object 1 time-of-flight (μs) (MSB, LSB) Byte3: Object 1 width Byte4: Object 1 peak amplitude . . Byte(3 × N – 3) – Byte(3 × N – 2): Object N time-of-flight (μs) (MSB, LSB) Byte(4 × N – 1): Object N width Byte(4 × N): Object N peak amplitude
6	Temperature and noise level result	Yes	0		2	Byte1: Temperature value Byte2: Noise level value
7	Transducer echo data dump	Yes	0		128	Byte1–Byte128: Echo data dump (array of 128 samples)
8	System diagnostics <sup>(3)</sup>	Yes	0		2	Byte1: Transducer frequency Byte2: Decay period time
9	Register read	Yes	1	Byte1: Register address	1	Byte1: Register data
10	Register write <sup>(4)</sup>	No	2	Byte1: Register address Byte2: Register data	0	
11	EEPROM bulk read	Yes	0		43	Byte1: USER_DATA1 data . . Byte43: P2_GAIN_CTRL data

- (1) If command 5 is executed while the echo data dump bit is enabled, the read out data will either be invalid or out-of-date. Only the echo data dump memory can be filled, or the threshold comparator be utilized per burst-and-listen or listen-only command.
- (2) To convert the object's time-of-flight in microseconds to distance in meters:  $distance(m) = [v_{sound} \times (MSB \ll 8 + LSB) \div 2 \times 1\mu s]$ . For improved burst-and-listen accuracy, add the additional burst offset to the originally calculated distance:  $distance_{burst\_offset}(m) = [v_{sound} \times (Pulses / Frequency) \div 2]$ . The speed of sound is typically assumed to be 343m/s at room temperature. Adjust the speed of sound as a function of ambient temperature:  $v_{sound} = 331m/s + (0.6m/s/^{\circ}C \times Temperature(^{\circ}C))$ .
- (3) If command 8 is executed before a run command, read out data is invalid.
- (4) For commands 10 and 22: Wait 60 μs if INIT\_GAIN, TVG, THR or P1\_GAIN\_CTRL or P2\_GAIN\_CTRL is written to before a read, otherwise wait 3.3 μs for other functions.

表 3. UART Interface Command List (接下页)

CMD[4:0]	COMMAND NAME	PGA460 RESPONSE	M-TO-S DATA BYTES	MASTER-TO-SLAVE DATA BYTES DESCRIPTION	S-TO-M DATA BYTES	SLAVE-TO-MASTER DATA BYTES DESCRIPTION
12	EEPROM bulk write <sup>(5)</sup>	No	43	Byte1: USER_DATA1 data . . Byte43: P2_GAIN_CTRL data	0	
13	Time-varying-gain bulk read	Yes	0		7	Byte1–Byte6 : TVGAIN0 - TVGAIN6 data
14	Time-varying-gain bulk write <sup>(5)</sup>	No	7	Byte1–Byte6: TVGAIN0 - TVGAIN6 data	0	
15	Threshold bulk read	Yes	0		32	Byte1–Byte32: P1_THR_0 - P2_THR_15 data
16	Threshold bulk write <sup>(5)</sup>	No	32	Byte1–Byte28: 1_THR_0 - 2_THR_15 data	0	
<b>BROADCAST</b>						
17	Burst and listen (Preset1)	No	1	Byte1: N - Number of objects to be detected (valid range is from 1 to 8)	0	
18	Burst and listen (Preset2)	No	1		0	
19	Listen only (Preset1)	No	1		0	
20	Listen only (Preset2)	No	1		0	
21	Temperature and noise-level measurement	No	1	Byte1: 0 - Temperature measurement 1 - Noise measurement 2–255 - Not used	0	
22	Register write <sup>(4)</sup>	No	2	Byte1: Register address Byte2: Register data	0	
23	EEPROM bulk write <sup>(5)</sup>	No	43	Byte1: USER_DATA1 data . . Byte43: P2_GAIN_CTRL data	0	
24	Time-varying-gain bulk write <sup>(5)</sup>	No	7	Byte1–Byte6: TVGAIN0 - TVGAIN6 data	0	
25	Threshold bulk write	No	32	Byte1–Byte32: 1_THR_0 - 2_THR_15	0	
26–31	RESERVED	No				

(5) For commands 12, 14, 16, 23, 24, and 25: Wait 50 μs before issuing a read command.

### 7.3.6.2.1.6 UART Operations

#### 7.3.6.2.1.6.1 No-Response Operation

The no-response operation on the UART interface is fairly straightforward. The command field specifies the address and command for the operation, where the subsequent data bytes, if any, are to be stored in the PGA460 device. The number of data bytes to be sent is predetermined by the UART command. The last field in the frame is the checksum field which is generated by the master. 图 26 shows an example of memory register write operation (command 10).



图 26. UART No-Response Example

注

If a NO-RESPONSE command arrives on the UART interface while another NO-RESPONSE command is also served or if the PGA460 device is busy performing functions, then the previous command is aborted and the new command is served immediately. This process is particularly important when the PGA460 device is running a record interval because of any of the Command0 through Command4 or Command17 through Command21 being previously received while another command is received on the UART. In this case, the PGA460 device aborts the previous command and terminates the current record interval after which it initiates a new command serving cycle.

#### 7.3.6.2.1.6.2 Response Operation (All Except Register Read)

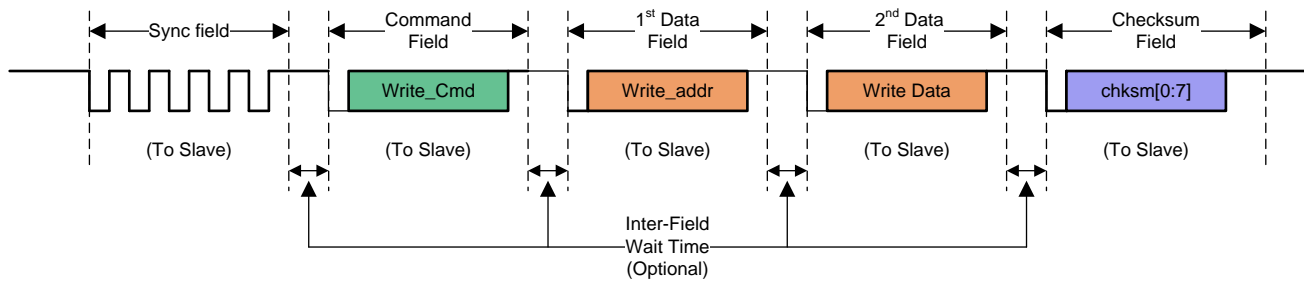
The response operation of the PGA460 UART interface is initiated with the master sending a response request. After the response request is received by the PGA460 device, the UART responds with the proper data of the command being requested. In a response operation, the master does not generate a checksum Field, rather it is generated by the PGA460.

注

Because the data direction changes (master device to PGA460 followed by PGA460 to master device) and because of the amount of processing time required by the PGA460 device to respond, a response delay time of 1-bit period occurs between the response request and the PGA460 response on the UART.

图 27 shows an example of the PGA460 response operation.





图 27. UART Response Example

### 7.3.6.2.1.6.3 Response Operation (Register Read)

Because the REGISTER READ command requires the master device to specify a register address in the PGA460 memory, an additional frame type is defined where the master issues the sync and command fields followed by the memory register address as the only byte field in the master frame and a master checksum as the last field. Following the master-to-slave transmission, the PGA460 device responds with a standard *PGA460 Response Operation* frame. 图 28 shows this operation.

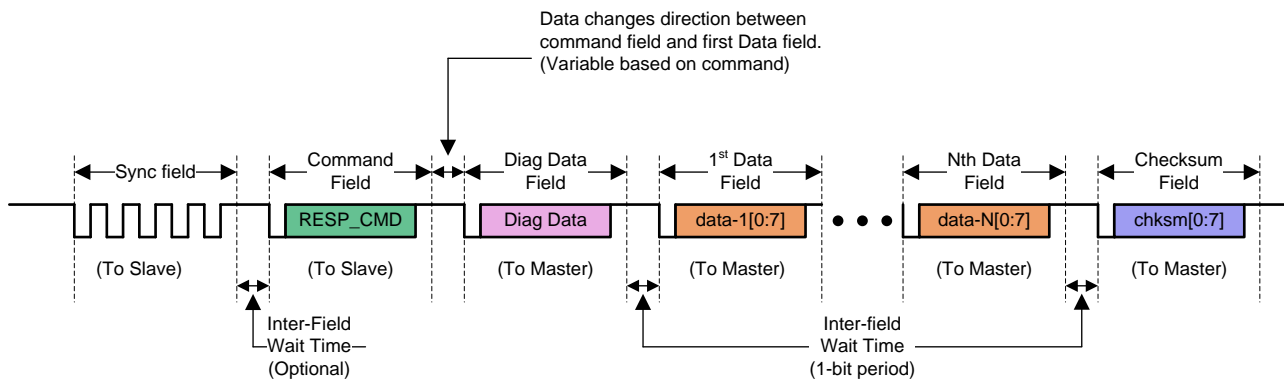

图 28. UART Register Read Response Example

### 注

If a RESPONSE command arrives on the UART interface while another NO-RESPONSE command is also served or if the PGA460 device is busy performing functions, then the PGA460 device responds with a diagnostic field (see the *Diagnostic Field* section) having an error status of 0 which denotes that the device is busy serving functions. If the PGA460 is currently serving a RESPONSE command while another RESPONSE command arrives, then the PGA460 device ignores the new RESPONSE command until it is done serving the previous RESPONSE command.

### 7.3.6.2.1.7 Diagnostic Field

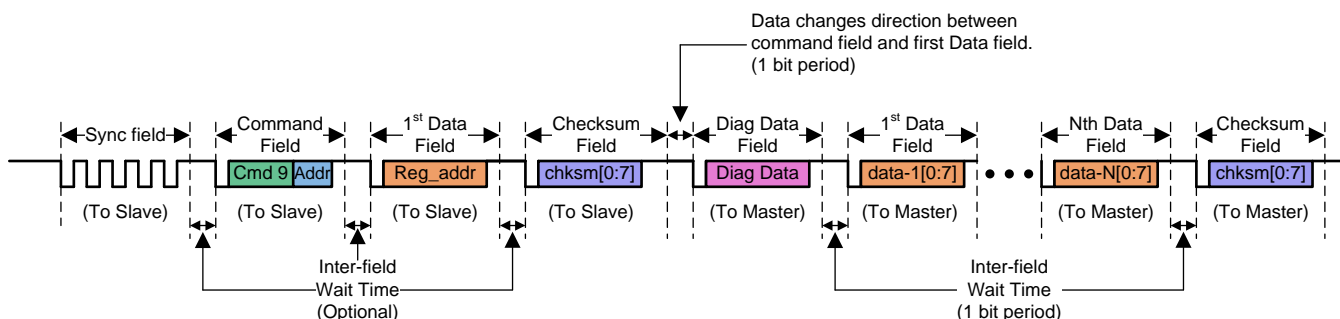
As described in the *Response Operation (Register Read)* section, the PGA460 device begins the response transmission with a diagnostic data field. This field contains UART communication error bits. If a particular bit is set to 1 then the associated communication error has occurred sometime between the last response operation and the current response operation. After a response operation is performed, the communication error bits are cleared. The diagnostic field is included in the slave generated checksum calculation. 图 29 shows the diagnostic data field.



**图 29. UART Diagnostic Data Field**

表 4 lists the diagnostic data error status bits.

The error status[7:6] bits in the diagnostic field are set to 01b so that the bit time transmitted by the slave can be easily measured. If more error status is required, these bit locations can be used to transmit the additional error status.

**表 4. UART Diagnostic Data Description**

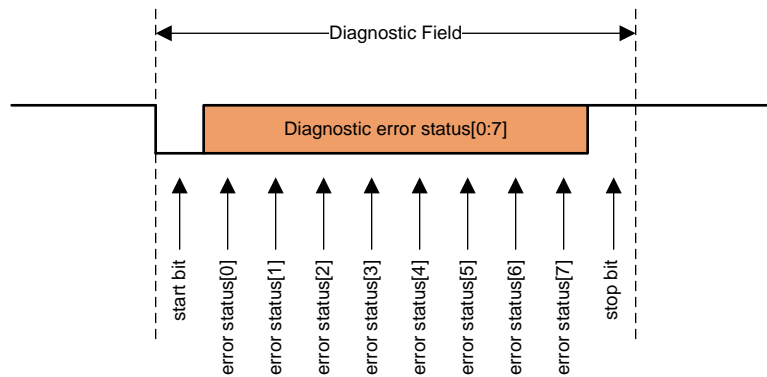
BIT	UART_DIAG = 0	UART_DIAG = 1
Error status [0]	PGA460 Device Busy	
Error status [1]	Sync field bit rate too high (>115200 bps)	Threshold settings CRC error
	Sync field bit rate too low (>115200 bps)	
Error status [2]	Consecutive sync field bit widths do not match	Frequency diagnostics error
Error status [3]	Invalid checksum received from master (essentially a calculated slave checksum does not match the checksum transmitted by the master)	Voltage diagnostics error
Error status [4]	Invalid command sent from master	Logic 0
Error status [5]	General communication error: <ul style="list-style-type: none"> <li>• SYNC filed stop bit too short</li> <li>• Command filed incorrect stop bit (dominant when should be recessive)</li> <li>• Command filed stop bit too short</li> <li>• Data field incorrect stop bit (dominant when should be recessive)</li> <li>• Data field stop bit too short</li> <li>• Data field PGA460 transmit value overdriven to dominant value during stop bit transmission</li> <li>• Data contention during PGA460 UART transmit</li> </ul>	EEPROM CRC error or TRM CRC error
Error status [6]		Logic 1
Error status [7]		Logic 0

### 7.3.6.2.1.8 USART Synchronous Mode

For fast (8 Mbps) communication between the master MCU and the PGA460 device, a fast USART synchronous mode is implemented. This mode uses and is only available on the RXD and TXD pins and is also using the SCLK pin as a clock input for communication to the device. In this mode the USART interface acts as a serial-shift register with data set on the rising edge of the clock and sampled on the falling edge of the clock. Differently than the USART asynchronous mode, the synchronous mode communication frame does not include a start,

stop, nor interfield wait bit which means that as soon as the data in one frame has completed, the next communication data frame follows immediately. USART Synchronous Mode is identical to a Serial Peripheral Interface (SPI) without a chip-select because the addressing is handled by the three-bit UART\_ADDR value to enable up to eight devices on a single bus. 图 30 shows the bit timing in synchronous mode and 图 31 shows the data flow for USART synchronous mode.



图 30. USART Synchronous Interface Bit Timing



图 31. USART Synchronous Mode Data Flow

As shown in 图 31, each data frame is 8-bits long with little endian format (least significant bit [LSB] first). All other functionality of the USART synchronous mode aligns with the USART asynchronous mode. Muxing of the IO pin of the USART synchronous mode is not possible and the IO pin transceiver is disabled when the device is communicating through USART in the case when the IO\_IF\_SEL bit is set to 1.

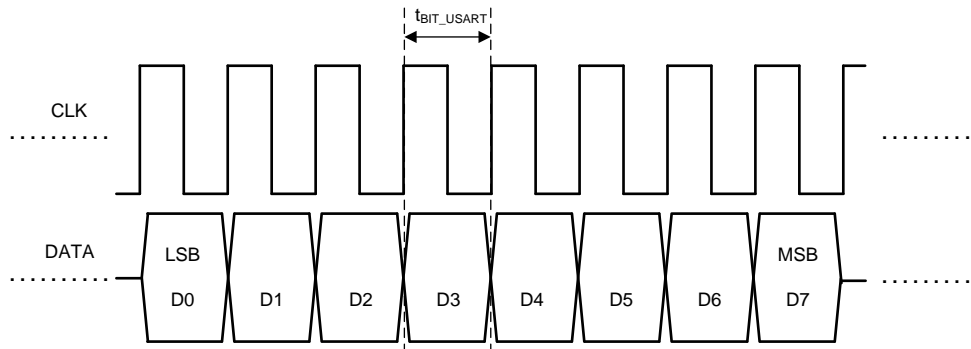
The PGA460 device can communicate in USART synchronous mode immediately when a rising clock on the SCLK pin is detected. No activation or deactivation of this mode is available.

If this communication mode is not used, the SCLK pin should be connected to GND to prevent noise triggering the clock input.

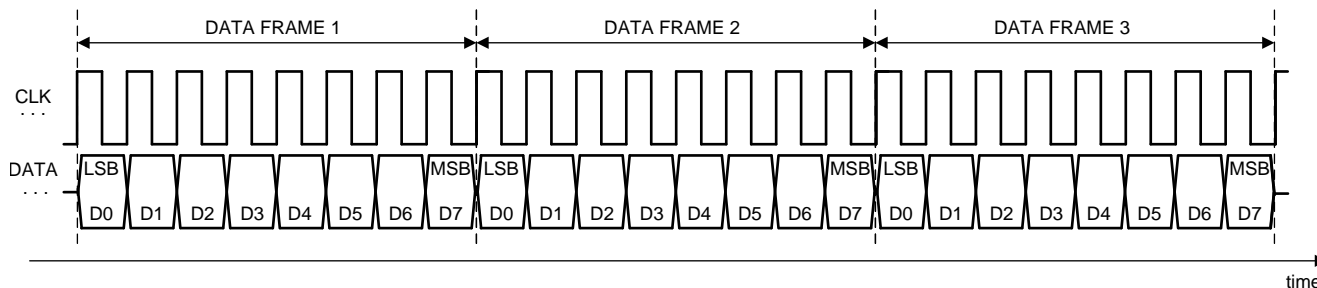
**7.3.6.2.2 One-Wire UART Interface**

The PGA460 device implements an option to connect the UART interface on the IO pin. In this case, the UART interface becomes a battery-voltage one-wire interface (OWI) because the IO pin is an open-drain type and implements a 10-kΩ pullup to the VPWR pin. This feature is possible because the communication on the UART interface is unidirectional at all times.

To enable the one-wire UART interface the IO\_IF\_SEL bit must be set to 1, in which case the internal communication multiplexers connect the digital logic of the UART interface to the IO-pin transceiver. The RXD and TXD pins are not changed and their operation is preserved.

Although UART communication through the IO pin, RXD pin, and TXD pin is allowed simultaneously, a possibility can occur for data collision in the case when the master controller is communicating to the IO pin while another master-controlled is trying to communicate through the UART transceiver on the RXD and TXD pins. Therefore, in an application where the IO pin is used, the RXD pin must be connected to the Hi-Z state which would cause the UART transceiver to disable when the PGA460 device has been enabled. For a detailed explanation, see the [Interface Description](#) section.

**注**

When UART sync mode is selected while the IO\_IF\_SEL bit is set to 1 (IO pin to UART interface) the IO transceiver is disabled.

**7.3.6.2.3 Ultrasonic Object Detection Through UART Operations**

The PGA460 UART interface has the capability to record up to 8 objects that would cut the assigned threshold. The result is expressed as a 1- $\mu$ s interval time value from the time when the burst stage is complete and the echo signal drops below the assigned threshold to the moment when any of the detected objects cut the assigned threshold again. Additionally, the width of the echo signal that cuts the threshold and the peak amplitude of the object is also measured and reported. If the object is detected at the end of record time, then object width is reported as 0xFF. The width of the echo that cuts the threshold is expressed as 4- $\mu$ s interval-time values. When a LISTEN ONLY command is used, the object detection starting point is at the start time of the record interval. 图 32 and 图 33 show an example of two objects being detected with BURST/LISTEN and LISTEN ONLY commands, respectively. Object detection cannot occur when the DATADUMP\_EN bit is set to 1.



图 32. UART Object Detection Signaling With Burst and Listen Command



图 33. UART Object Detection Signaling With LISTEN ONLY Command

The comparison is done between the assigned threshold and the amplitude of the signal at the output of the DSP data path. If the threshold level is higher in value than the signal amplitude then no object is being detected. If the signal amplitude is higher in value than the threshold level denoting an echo reflection then an object is detected and the time-mark is captured. When the record time reaches the end of the record defined by the Px\_REC parameters and the number of objects to be detected is still not achieved, the record interval is complete and the undetected object locations are assigned a value of 0xFF. At this point the device is ready for the next command which should be USART command 5. In case the number of objects to be detected is fulfilled before the end of record interval, the device interrupts the record cycle because the number of objects has already been detected and the device is ready for command 5. Issuing command 5 before issuing command 0 to 4 provides unpredictable data.

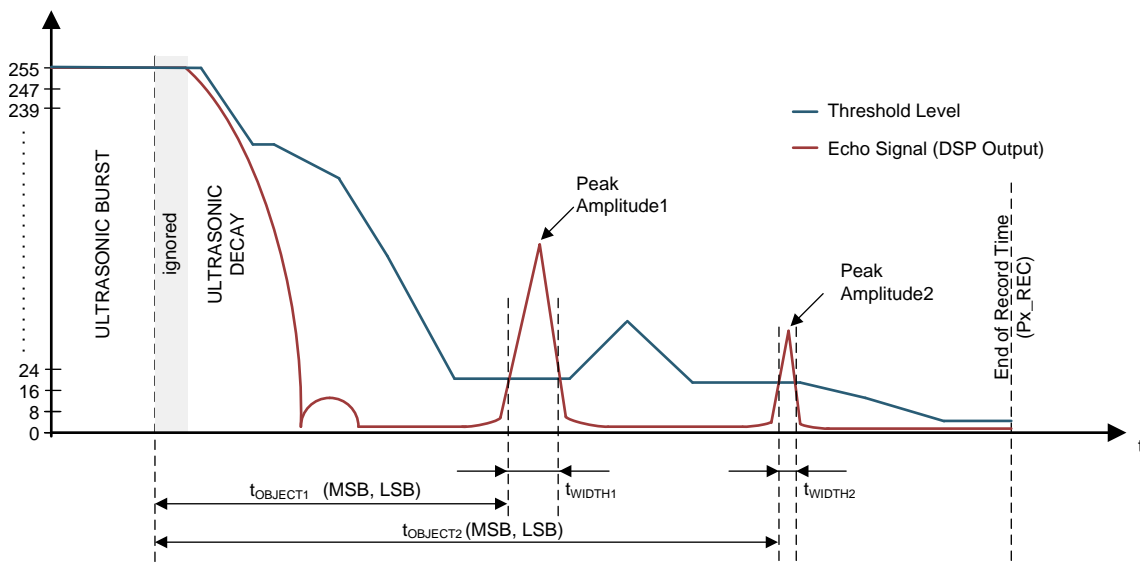
The following example shows how to use the PGA460 UART commands for object detection:

1. On PGA460 power up, the master configures the following:
  - EEPROM by using the EEPROM bulk write command
  - Time-varying gain by using the time-varying gain bulk write command
  - Threshold parameters by using the threshold bulk write command or by independently writing to a particular parameter by using the register write command
2. When the PGA460 device has been configured, the master device issues a run command with any of the following commands:
  - BURST/LISTEN (Preset1)
  - BURST/LISTEN (Preset2)
  - LISTEN ONLY (Preset1)
  - LISTEN ONLY (Preset2)

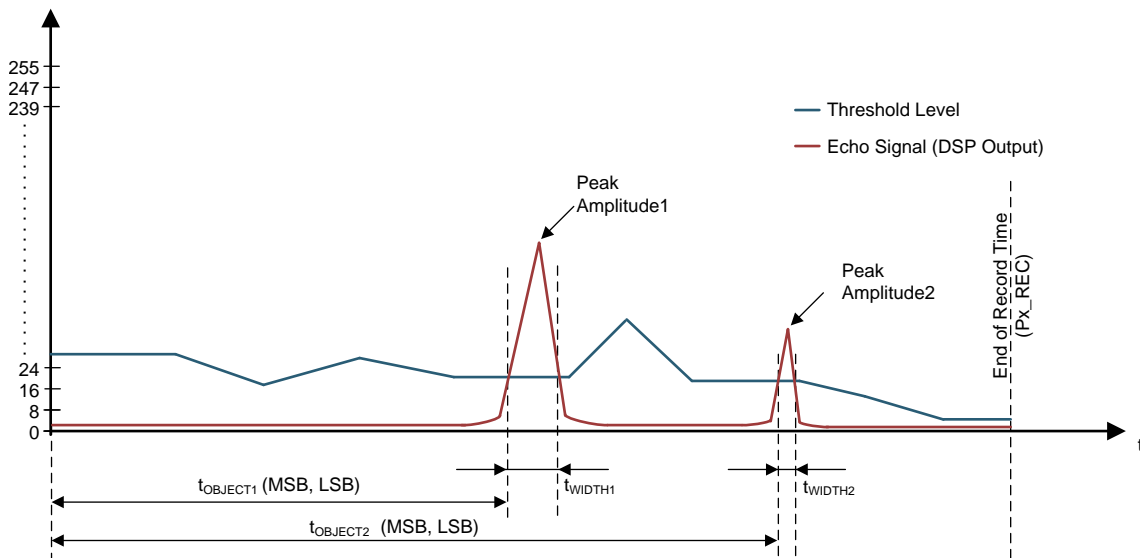
Following a successful receive of any of the these run commands the PGA460 device immediately runs the requested action.

3. When the record interval has expired, the master device can issue the ultrasonic measurement result command to collect the data from the PGA460 device.

### 7.3.6.3 In-System IO-Pin Interface Selection

The PGA460 device is factory programmed with the time-command interface enabled on the IO-pin. In a system where the end user uses the IO-pin in a one-wire UART mode, two possible options of enabling the one-wire UART interface on the IO-pin are available as follows:

- If access to the UART RXD and TXD pins is possible then the user can set the IO\_IF\_SEL bit to 1 in the EEPROM memory space and then execute an EEPROM program command to store the configuration for future use.
- If access to the RXD and TXD pins is not possible (assuming the end product has already been assembled) then the device can be toggled between interfaces by using the pattern on the IO-pin shown in [Figure 34](#).

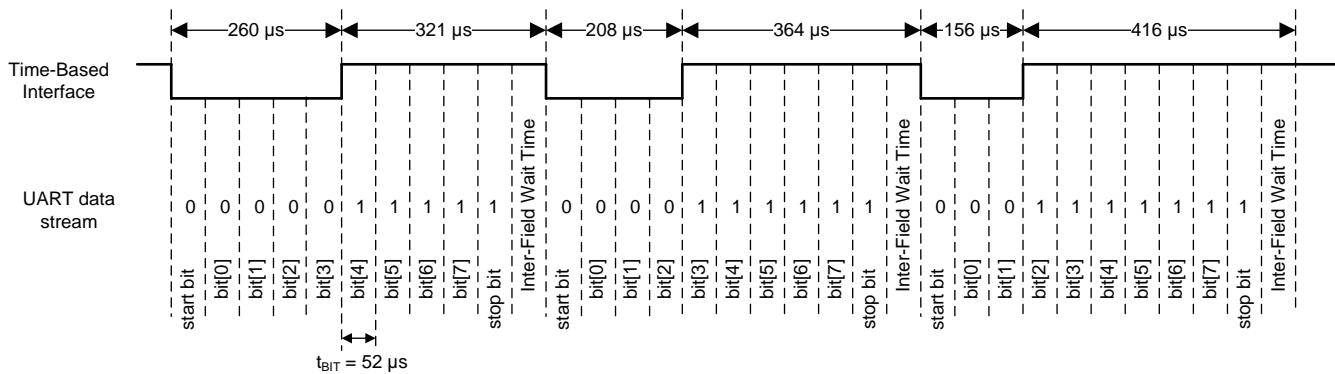

**Figure 34. IO-Pin Interface Toggle Pattern**

As show in [Figure 34](#), the data format is selected in a specific way so that a time-command interface and a UART interface can easily reproduce the pattern. The following two scenarios are possible:

**IO-Pin in time-command interface while the master device is in UART interface** In this case the master device can send a UART frame with the following data: 0xF0 followed by 0xF8 followed by 0xFC while the UART baud-rate is 19200 bps.

---

注

In this case the master device does not generate a sync field.

---

**IO-Pin in UART interface while the master device is in time-command interface** In this case the master device generates three time-command pulses with time durations as shown in [图 34](#).

As soon as the data is received by the PGA460 device, the interface on the IO-pin is toggled. The pattern in [图 34](#) toggles the value of the IO\_IF\_SEL bit in the EEPROM memory; however, it does not program the EEPROM. Therefore, as soon as the PGA460 Interface is set to the target interface, the master controller must issue a command to program the EEPROM with the desired configuration.

---

注

In case of toggling the selection pattern for the IO interface option, a STAT2 bit is triggered to 1. Upon reading, the STAT2 bit is cleared.

---

### 7.3.7 Echo Data Dump

#### 7.3.7.1 On-Board Memory Data Store

The PGA460 device offers a data-dump function where the data at the output of the digital data path can be extracted in a raw digital format. This function is usually required for the ultrasonic system to be properly tuned and to make correct time-varying gain and threshold adjustments. Additional uses can include system evaluation and testing.

The echo data-dump function can be enabled for any of the four BURST/LISTEN or LISTEN ONLY commands and is enabled by the DATADUMP\_EN bit in the EE\_CNTRL register. When enabled, and upon receiving a BURST/LISTEN or a LISTEN ONLY command, the PGA460 device holds the IO pin low for the entire record interval thus signaling the master MCU that data-dump cycle is in progress. When the data-dump cycle is complete the data can be extracted by the data dump read command. For more information on the PGA460 device commands, see [表 2](#).

The data-dump memory is composed of a 128-byte data memory array. Echo data is down sampled to allow capturing of the complete recording interval. The down sampling amount depends on the record time-length parameter for the preset of interest set by the P1\_REC and P2\_REC bits in the REC\_LENGTH EEPROM register. During the process of down-sampling, a peak hold function is performed and therefore only the highest level values after down-sampling are stored in the data-dump memory. When the DATADUMP\_EN bit is 1, object detection and measurement is disabled.

The following is a brief example to present the data dump implementation:

1. The DATADUMP\_EN bit is set to 1.
2. The P1\_REC bit is set to 0x01, which selects a record time-length interval of 8192  $\mu$ s. Because the output rate of the digital data path is 1  $\mu$ s/sample, the total record interval has 8192 samples.
3. When any of BURST/LISTEN (Preset1) or LISTEN ONLY (Preset1) commands is executed, one sample location in the data-dump memory is written with the highest (peak) value of  $8192 / 128 = 64$  samples.

Therefore the first data-dump value is the highest value of the 0–63 sample range while the last data-dump value is the highest value 8127–8191 sample range.

#### 7.3.7.2 Direct Data Burst Through USART Synchronous Mode

In the case where each 1- $\mu$ s Data-Path sample is needed to be extracted for further analysis, the PGA460 device offers a Test Mode where the Raw Digital data can be extracted at different points in the Digital data path as shown in [图 35](#). Data burst is enabled when DP\_MUX value is greater than 0 and less than 5, then the object detection and measurement is disabled.

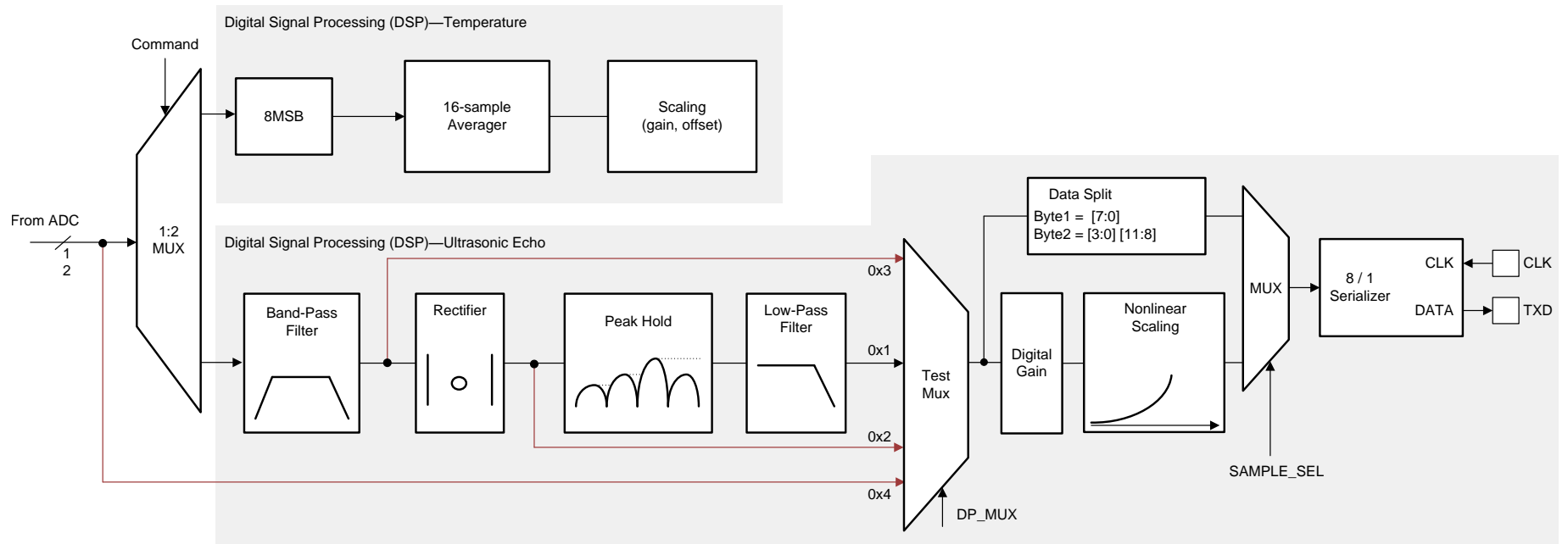

This feature is only possible in USART Synchronous Mode.

图 35. Direct Data Burst



To enable this mode, the Digital Data-Path Mux can select the source signal to be burst out of the device by setting the DP\_MUX parameter in the device memory. Once the DP\_MUX parameter is enabled (set to a value other than 0x00), and if any of the SEND/RECEIVE, Receive Only or TEMPERATURE READ commands are issued using the standard UART command method, the selected source signal is passed through the Digital Multiplexer and Serialized by the 8/1 Serializer block. This signal is immediately outputted on the UART TXD pin that now acts as a data output pin, while the master sends clock pulses to the CLK pin.

It is important that after issuing any of these commands the master does not stop sending clock pulses on the CLK pin until the Bus is idle. Once a Checksum received is verified and the bus is idle, that is considered the end of the Burst data. This is needed for proper data synchronization in the PGA460 device. For further explanation on the USART Synchronous communication mode, see the [USART Synchronous Mode](#) section.

图 36 shows the format of the order of the data stream coming out of the PGA460 device.



图 36. Direct Data Burst Data Format

As shown in 图 36, the output data-stream starts with a PGA460 diagnostic data field, followed by number of data bytes and ends with a checksum field calculated on the diagnostic data byte and all data bytes. The number of data bytes depends on the number of samples extracted from the PGA460 device, which depends on the Recording Time Interval of the current command. The recording time Interval is determined by the P1\_REC and P2\_REC parameters in the EEPROM memory while the sampling rate of the ADC and digital signal path is 1  $\mu$ s / Sample. From here it can be calculated that the number of samples is equivalent to the recording time when expressed in microseconds.

The digital output offers two modes of operation based on the SAMPLE\_SEL parameter:

**When SAMPLE\_SEL = 0** The output of the data path is selected by the Digital Data-Path Test Mux and the data length is 8 bits/sample long. For the LPF output, we now use the active digital gain select to determine which 8 bits are sent out. For all the others, if the active digital gain select = 0 then we get the 8 MSB bits, else the PGA460 sends the 8 LSB bits. In this case, the sample rate is 1  $\mu$ s, meaning every sample that the ADC outputs will also be sent out of the PGA460 device.

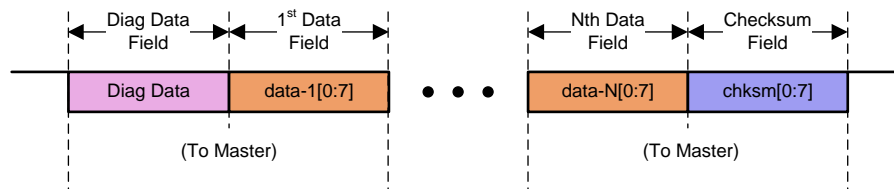
**When SAMPLE\_SEL = 1** The output of the data path is selected by the digital data path test mux. However, the full 12bits/sample data length is sent out of the PGA460 device. In this case, the sample rate is 2  $\mu$ s, meaning every 2nd sample produced by the ADC will be sent out. The 12 bit data is split into two bytes and sent in the order LS Byte followed by the MS Byte. The MS Byte is padded with a 4 bit sample counter so that the master controller can track the order of samples from the PGA460 device.

### 注

For both of the previously listed options, the nonlinear scaling block is only enabled if the data is extracted from the Low-Pass filter (DP\_MUX = 0x1). In all other cases, the nonlinear scaling block is disabled.

### 7.3.8 Low-Power Mode

The PGA460 device implements a low-power mode where the current consumption is significantly reduced to preserve system power. The low-power mode feature is enabled by setting the LPM\_EN bit in the EEPROM. If this bit is set, the PGA460 device goes into low-power mode after a certain period of inactivity as defined by the LPM\_TMR bits in the FVOLT\_DEC EEPROM register. Inactivity is defined when no activity occurs on the communication interfaces such as commands to BURST/LISTEN, LISTEN ONLY, or to configure the device. Any command causes a reset of the timer. During the programming of the EEPROM, the timer remains in reset.



In low-power mode the PGA460 device can wake up in two different ways based on the interface used for communication: time-command interface and USART interface. These ways are described in the following sections.

### 7.3.8.1 Time-Command Interface

The device wakes up immediately after a deglitched falling edge on the IO pin is detected. The master controller must generate a wake-up signal defined as a dominant pulse (logic 0) on the time command interface with a length of at least 300  $\mu\text{s}$ . After the wake-up pulse is complete, at least one command processing dead-time must be allowed before starting a time-command pulse which is shown in [图 37](#).



图 37. Time Command Interface Wake-Up Pulse

### 7.3.8.2 UART Interface

The master device must generate a wake-up signal defined as a dominant pulse (logic 0) on the UART interface with a length of at least 300  $\mu\text{s}$ . After the wake-up pulse is complete, at least one inter-byte space must be allowed before starting a UART transmission. [图 38](#) shows an example of a UART wakeup.

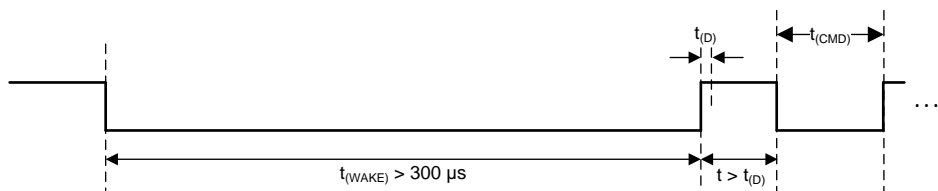

图 38. UART Wake-Up Pulse

## 7.3.9 Transducer Time and Temperature Decoupling

### 7.3.9.1 Time Decoupling

The PGA460 device has the option to decouple the transducer from the transformer and the rest of the driving circuitry during the echo detection stage of the record interval. The transducer is less exposed to noise generated by the driving circuit during this process and is less loaded, meaning the detected echo is capable of producing a higher voltage swing to be detected by the PGA460 device. For this function, the DECPL pin on the PGA460 device is used that drives the gate (or base) of an external transistor,  $Q_{DECPL}$ . During the burst and decay stages of the record interval the DECPL pin is high (3.3 V or 5 V depending on the IOREG level) and enables the external transistor which then connects the transformer driving circuit to GND and couples it to the transducer. The time-decoupling function is selected when the DECPL\_TEMP\_SEL bit in the EEPROM is set to 0.

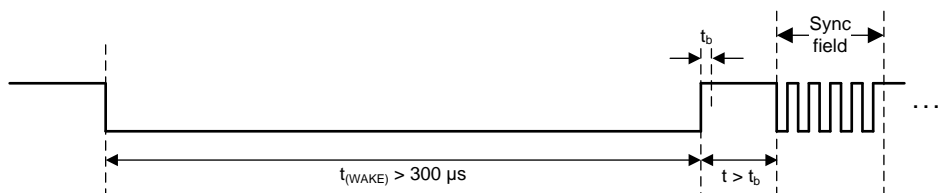
When the burst stage is complete, a timer is started which times to the value defined by the DECPL\_T bit in the EEPROM. When this time has elapsed, the state of the DECPL pin becomes low (GND) which means that the external transistor,  $Q_{DECPL}$ , is disabled which disconnects the transformer secondary coil from the transducer. [图 39](#) shows the circuit implementation.

### 7.3.9.2 Temperature Decoupling

Similarly to time decoupling, a temperature-decoupling function has been implemented in the PGA460 device that can connect and disconnect a temperature-compensation capacitor at a certain temperature point to compensate for the temperature nonlinearity of the transducer. By using this function, the transducer frequency is assumed to remain within limits across temperature. To enable this function, the DECPL\_TEMP\_SEL bit must be set to 1.

Upon receiving a run command, the PGA460 device executes the TEMPERATURE MEASUREMENT command first and compares the result with the temperature setting defined by the DECPL\_T bit in the EEPROM. If the temperature measured is higher than the value based on the DECPL\_T bit, then the DECPL pin is low (GND) causing the Q<sub>DECPL</sub> transistor to be disabled and the temperature compensation capacitor to disconnect. If the measured temperature is less than the value based on the DECPL\_T bit, the DECPL pin is high (3.3 V or 5 V depending on the IOREG level), the Q<sub>DECPL</sub> transistor is enabled and the temperature compensation capacitor is connected to the circuit. 图 40 shows the circuit implementation.



图 39. Transducer Time Decoupling



图 40. Transducer Temperature Decoupling

### 7.3.10 Memory CRC Calculation

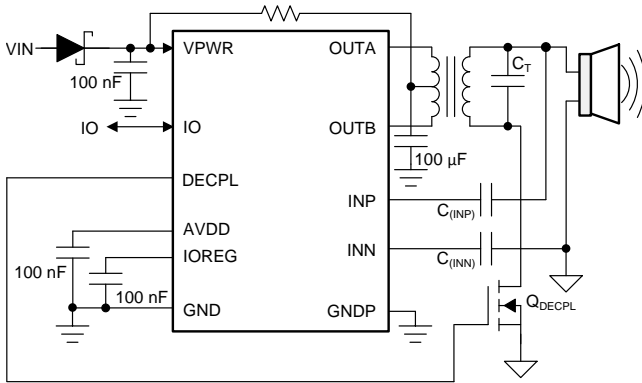
The PGA460 implements a cyclic redundancy check (CRC) that is a self-contained algorithm to verify the integrity of the EEPROM stored data and threshold settings. When an EEPROM program or EEPROM-reload operation is executed, or when a threshold register is written, the CRC controller calculates the correct CRC value and writes it to the corresponding registers: For EEPROM memory, this value is written to the EE\_CRC register. For threshold settings, this value is written to the THR\_CRC register.

A CRC is performed at power-up when an EEPROM reload command is issued. The CRC algorithm for all memory blocks is the same and is shown in 公式 6 with an initial seed value of 0xFF and uses MSB ordering. This calculation is performed byte wise starting from the MSB to the LSB. The data is concatenated as follows:

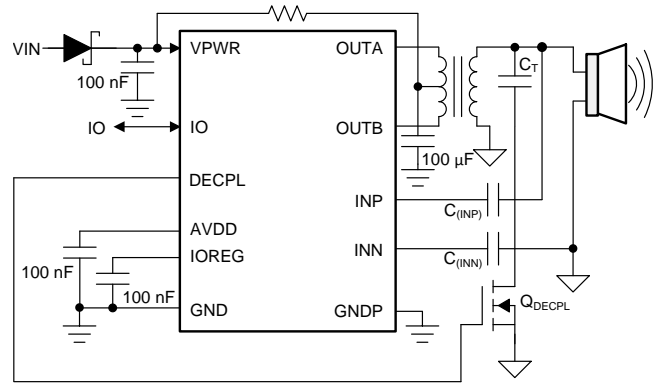
- For EEPROM memory: Concatenation starts with MSB USER\_DATA1 (0x00) to LSB P2\_GAIN\_CTRL (0x2A) and calculated CRC is stored in the EE\_CRC register (0x2B)
- For threshold settings: Concatenation starts with MSB P1\_THR\_0 (0x5F) to LSB P2\_THR\_15 (0x7E) and calculated CRC is stored in the THR\_CRC register (0x7F)

$$X^8 + X^2 + X + 1 \text{ (ATM HEC)} \tag{6}$$

The results of the CRC check are stored in the DEV\_STAT0 register and can be directly read through the UART interface, while the time-command interface reports these in *Status Bit3* and *Status Bit1*. For more information on the time-command interface status bits, see the [Time-Command Interface](#) section. For the default values, see the [Register Maps](#) section.

### 7.3.11 Temperature Sensor and Temperature Data-Path

The PGA460 device has an on-chip temperature sensor and a dedicated temperature data path for accurate temperature measurement. The output value is provided as an unsigned 8-bit number from -40°C to +125°C. The temperature sensor measurement can be used to adjust the variation of the transducer performance as the ambient temperature changes. The temperature measurement's sample and conversion time requires at least 100 us after the temperature measurement command is issued. Do not send other commands during this time to allow the temperature value to properly update.

The output of the temperature digital data path can be read by using the time-command interface of the UART interface. The value provided is related to the measured temperature as shown in 公式 7.

$$T = \frac{T_{(VAL)} - 64}{1.5}$$

$$T_{(VAL)} = \text{ADC}_{\text{UNCOMP}} \times \left( 1 + \frac{\text{TEMP\_GAIN}}{128} \right) + \text{TEMP\_OFF}$$

where

- $T_{(VAL)}$  is value read from the device using TCI or UART commands.
- $T$  is the temperature.
- $\text{TEMP\_GAIN}$  and  $\text{TEMP\_OFF}$  are signed values in the limits from  $-8$  to  $+7$ .

Because the output value of  $T_{(VAL)}$  after the calculation can result in a decimal number, the value is rounded-up to the closest integer value.

The temperature digital data path consists of a 16-sample averager and a scaling block as shown in 图 41. The 16-sample averaging block averages 16 temperature measurements arriving at a rate of 1 sample/ $\mu\text{s}$  into one result to remove temperature measurement variations. The scaling block is used to adjust the Gain and the offset parameter to better calibrate the temperature sensor. These two parameters are programmed using  $\text{TEMP\_GAIN}$  and  $\text{TEMP\_OFF}$  bits in the  $\text{TEMP\_TRIM}$  EEPROM register.



图 41. Temperature-Sensor Signal Path

Before compensation ( $\text{TEMP\_GAIN}$  bit set to 0,  $\text{TEMP\_OFF}$  bit set to 0),  $T_{(VAL)}$  is same the value converted by the ADC. As previously above, the user can compensate for variations in operating conditions (VPWR), board design, and configuration of the device by performing a two-temperature measurement and trim. After compensation,  $T_{(VAL)}$  can be converted to an absolute temperature using 公式 7. As the VPWR is increased, power dissipation increases and the internal die temperature can be different from the ambient temperature. The temperature sensor always indicates the die temperature.

Without calibrating  $\text{TEMP\_GAIN}$  and  $\text{TEMP\_OFF}$ , the ambient temperature can be approximated from the die temperature reading using 公式 8

$$T_{\text{Ambient}} (\text{°C}) = T_{\text{Die}} - [R_{\theta\text{JA}} \times (\text{VPWR} \times I_{\text{VPWR\_RX\_ONLY}})]$$

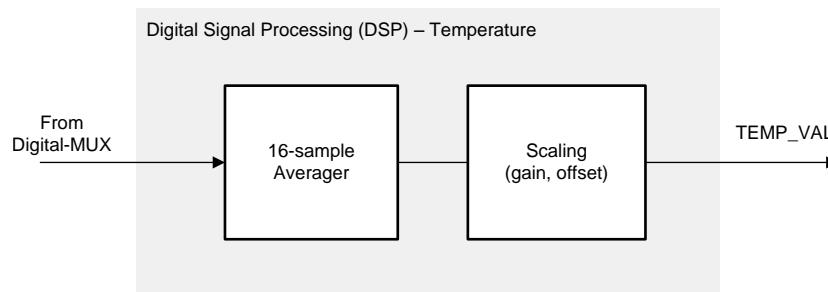
where

- $R_{\theta\text{JA}}$  ( $\text{°C/W}$ ) is the Junction-to-ambient thermal resistance of  $96.1\text{°C/W}$ .
- $\text{VPWR}$  (V) is the input voltage.
- $I_{\text{VPWR\_RX\_ONLY}}$  (mA) is the supply current from VPWR pin during listen only mode of 12mA.

### 7.3.12 TEST Pin Functionality

The PGA460 TEST pin serves multiple purposes including:

- Allows the user to extract internal signals from the PGA460 device.
- Selects the output voltage of the digital pins which enables a 3.3-V MCU or a 5-V MCU to be connected to the device without using any external voltage translators. The RXD, TXD, SCLK, DECPL, and TEST pins are affected by this selection.

Internal signals on the TEST pin can be extracted by selecting a predefined signal through the internal test mux. The TEST\_MUX register parameter is used to select this signal. 表 5 lists the possible PGA460 internal signals that are output at the TEST pin.

表 5. Internal Signals that can be Muxed out on the TEST Pin

TEST_MUX VALUE	SIGNAL NAME	TYPE	DESCRIPTION
0x00	Hi-Z (disabled)	Analog	The TEST pin is in the high impedance state
0x01	ASC Output		SAR ADC input after the ADC buffer
0x02	Reserved		
0x03	Reserved		
0x04	8MHz Clock	Digital	8-MHz clock output from PGA460
0x05	ADC Sample Clock		1- $\mu$ s ADC sample Clock
0x06	Reserved		
0x07	Reserved		

When used as an analog test-mux output, the TEST pin output voltage can change from 0 V to 1.8 V while the common mode voltage is set to 0.9 V.

The digital voltage-level selection performed by the TEST pin is executed at device power up. On power-up, the device checks the level of the TEST pin. If the level is low, the digital output pins operate at 3.3 V. If the TEST pin is tied high (3.3 V or 5 V are both considered high state), the digital output pins operate at a 5 V. This condition is latched in the PGA460 device so that the test mux can further use the TEST pin as previously described. If the application requires that a 5-V digital output is used and a test mux output must be extracted from the PGA460 device, then a weak pullup resistor on the TEST pin can be connected as shown in 图 42.

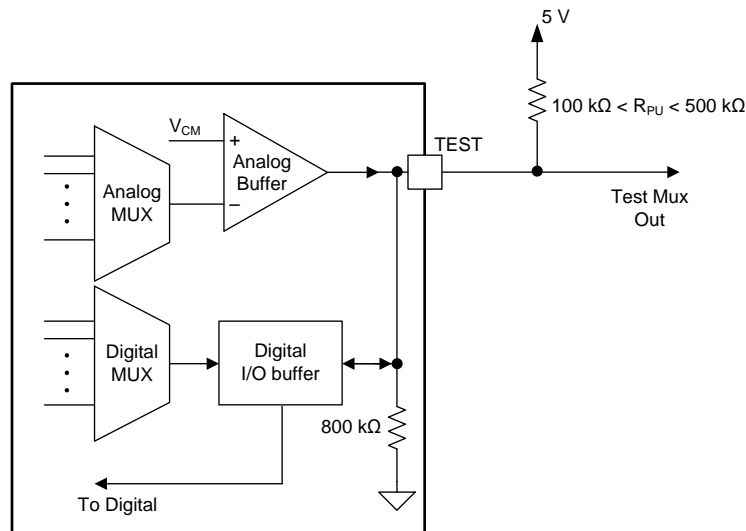

Copyright © 2017, Texas Instruments Incorporated

图 42. Test Pin Test Mux Output Application

As shown in [图 42](#), the resistor ( $R_{PU}$ ) is connected to a permanent power supply and a current path to ground is generated through the  $R_{PU}$  resistor and the 800-k $\Omega$  internal resistance. This configuration is no problem for the system; however, it might cause a small quiescent-current increase in applications that require the use of the PGA460 low-power mode to preserve energy. In this case, the TEST pin can be connected to a GPIO pin on the external MCU that can output a logic low or high state on the TEST pin to select the voltage level at device start-up and later disable the GPIO output to preserve energy or reconfigure the GPIO as an input in case the MCU uses any of the PGA460 test output signals. The external pullup resistor is only required for CMOS 5-V UART communication and is not required for 3-V communication.

## 7.4 Device Functional Modes

The PGA460 device functional modes as defined as:

**Active mode** After the power-up sequence is complete, the device waits for a BURST/LISTEN or LISTEN ONLY command to drive the transducer, and amplify and condition the received echo. In this mode, the device can also be configured with various parameters, and data about the detected object can be queried from the device. All these functions are achieved using commands defined in [Interface Description](#) section.

**Low-power mode** The device can be configured to go to this mode after a defined period of inactivity as defined in [Low-Power Mode](#) section. In this mode most of the blocks are turned off to dramatically reduce current consumption. The device can come out of this mode with commands on the interface as described in the [Time-Command Interface](#) and [UART Interface](#) section. In this mode, the device cannot burst or listen for an echo. All configuration stored in volatile memory is also lost. This includes all threshold timing and level values.

## 7.5 Programming

[图 43](#) and [图 44](#) are flow charts showing how the PGA460 device can be configured using the USART or the TCI interfaces respectively.

Programming (接下页)



图 43. UART Communication Flow Chart

Programming (接下页)

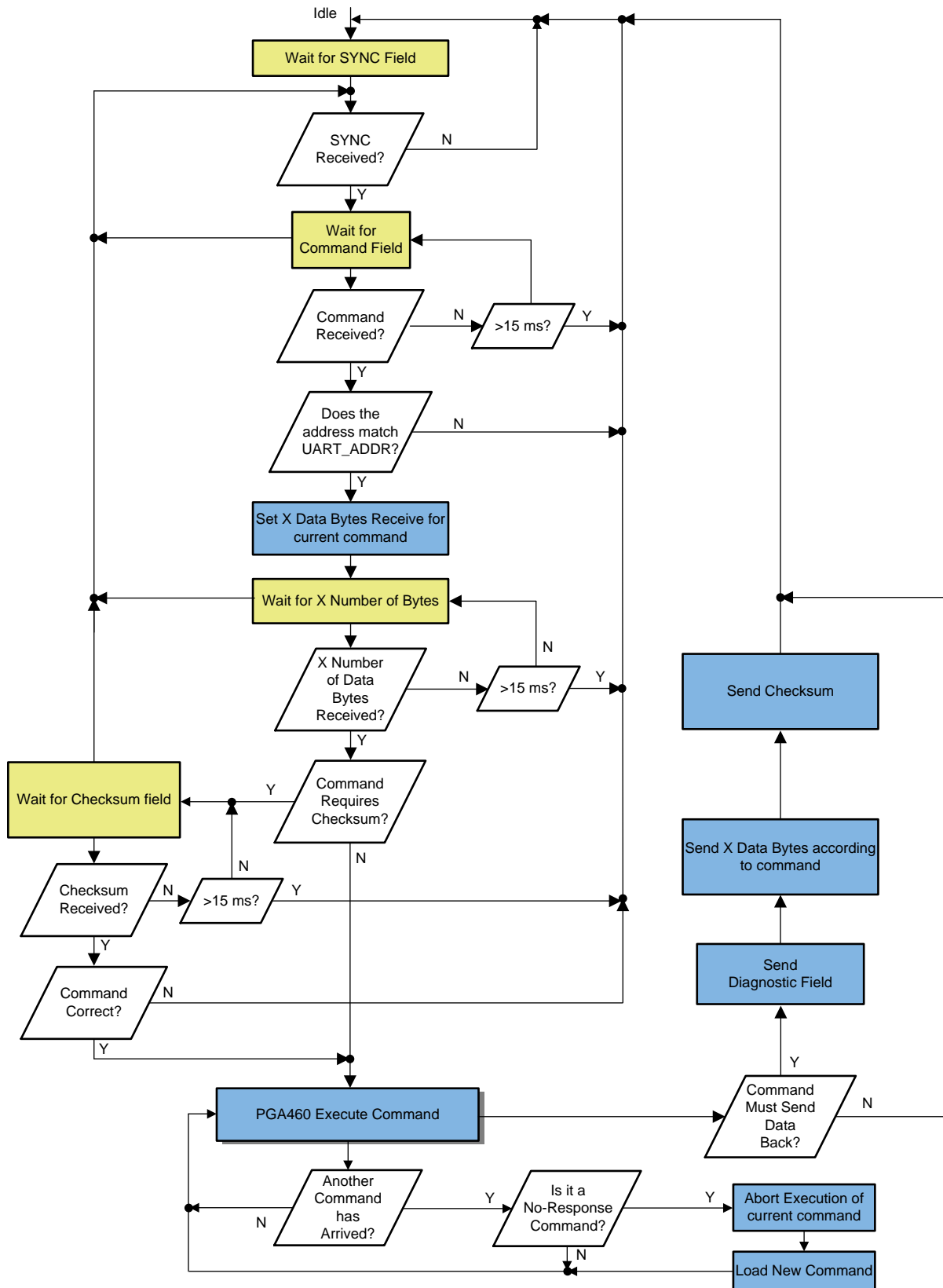

图 44. Time-Command Interface Communication Flow Chart

## Programming (接下页)

### 7.5.1 UART and USART Communication Examples

The following are some examples of UART and USART communication:

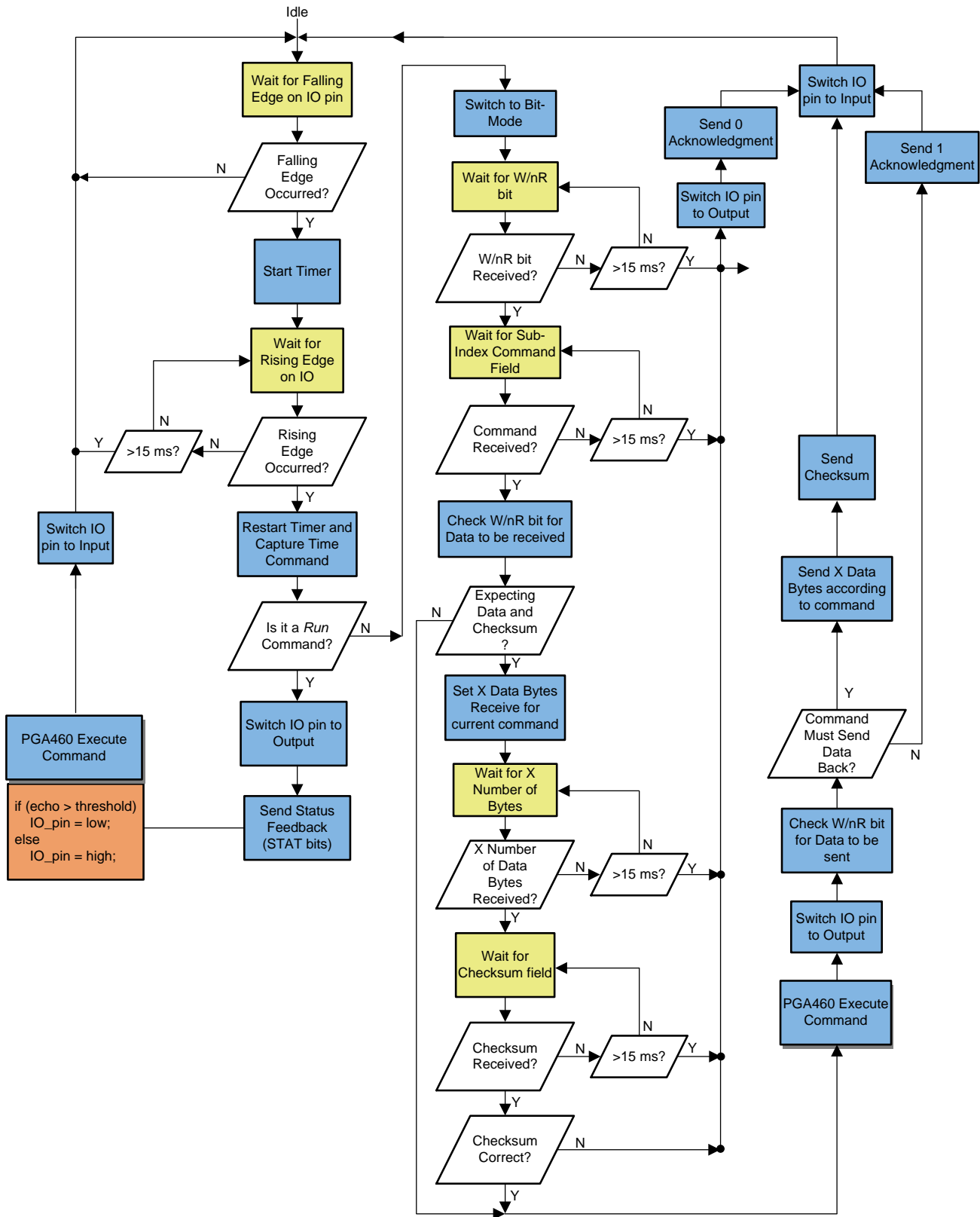
**Example1** – Read register 0x1B, where PGA460 address is 0x0:

Master to PGA460: 0x55, 0x09, 0x1B, 0xDB ...

PGA460 to master: ... 0xdiag, 0xdata, 0xchecksum

**Example2** – Write register 0x40, data 0x80, where PGA460 address is 0x0:

Master to PGA460: 0x55, 0x0A, 0x40, 0x80, 0x35

PGA460 to master: No response, idle (0xFF)

**Example3** – Execute command 0 (Burst/Listen Preset1) to detect 1 object, where PGA460 address is 0x0:

Master to PGA460: 0x55, 0x00, 0x01, 0xFE

PGA460 to master: No response, idle (0xFF)

**Example4** – Execute command 5 (ultrasonic measurement result), where PGA460 address is 0x0, assuming previous execution of [Example3](#) where the master has commanded PGA460 to search for one object:

Master to PGA460: 0x55, 0x05, 0xFA ...

PGA460 to master: ... 0xdiag, 0xtime\_of\_flight\_in\_us\_[MSB],

0xtime\_of\_flight\_in\_us\_[LSB], 0xtime\_object\_width\_in\_us, 0xpeak\_amplitude\_in\_LSB, 0xchecksum

---

#### 注

A repeatable sequence of 0xFF signifies the idle bus state.

---

## 7.6 Register Maps

### 7.6.1 EEPROM Programming

To program the EEPROM, follow these steps:

1. Send an EEPROM program command using UART or TCI with a unique *unlock* pattern on 4-bits. The program bit is set to 0 in register 0x40. The unlock passcode is 0x Dh.
2. Immediately send the same UART or TCI command with the program bit set to 1.

If any other command is issued after the unlock code ([Step 1](#)), the EEPROM program is initiated. Also, if the unlock command in [Step 1](#) is not correct, the EEPROM is not programmed. The EEPROM is locked again automatically after each program command

---

#### 注

This EEPROM passcode is applicable by communication in the UART mode and for TCI mode done through Config command 11.

---

### 7.6.2 Register Map Partitioning and Default Values

The register map in the [Register Maps](#) section is organized as follows:

- Address 0h-2Bh: EEPROM nonvolatile memory. Content in these registers is preserved during power cycle and low-power mode.
- Address 40h-4Dh and address 5Fh-7Fh: Register-based volatile memory. Content in these registers is lost during power cycle and low-power mode.
- Address 2Ch-3Fh and address 4Eh-5Eh are reserved for Texas Instruments internal use and are not accessible to the user.

All registers are reset to the default values as shown in the [Register Maps](#) section. However, the PGA460 EEPROM is programmed to values as described in [表 6](#). These values are loaded into registers at power up, overwriting the default reset values.



**Register Maps (接下页)**
**表 6. EEPROM Factory Default Values**

EEPROM REGISTER	REGISTER ADDRESS	Default Value
USER_DATA1-USER_DATA-20	0h-13h	00h
TVGAIN0	14h	AFh
TVGAIN1	15h	FFh
TVGAIN2	16h	FFh
TVGAIN3	17h	2Dh
TVGAIN4	18h	68h
TVGAIN5	19h	36h
TVGAIN6	1Ah	FCh
INIT_GAIN	1Bh	C0h
FREQUENCY	1Ch	8Ch
DEADTIME	1Dh	00h
PULSE_P1	1Eh	01h
PULSE_P2	1Fh	12h
CURR_LIM_P1	20h	47h
CURR_LIM_P2	21h	FFh
REC_LENGTH	22h	1Ch
FREQ_DIAG	23h	00h
SAT_FDIAG_TH	24h	EEh
FVOLT_DEC	25h	7Ch
DECPL_TEMP	26h	0A
DSP_SCALE	27h	00h
TEMP_TRIM	28h	00h
P1_GAIN_CTRL	29h	00h
P2_GAIN_CTRL	2Ah	00h
EE_CRC	2Bh	Auto calculated on EEPROM burn

**7.6.3 REGMAP Registers**

Table 7 lists the memory-mapped registers for the REGMAP. All register offset addresses not listed in Table 7 should be considered as reserved locations and the register contents should not be modified.

**Table 7. REGMAP Registers**

Offset	Acronym	Register Name	Section
0h	USER_DATA1	User general purpose data register 1	<a href="#">Go</a>
1h	USER_DATA2	User general purpose data register 2	<a href="#">Go</a>
2h	USER_DATA3	User general purpose data register 3	<a href="#">Go</a>
3h	USER_DATA4	User general purpose data register 4	<a href="#">Go</a>
4h	USER_DATA5	User general purpose data register 5	<a href="#">Go</a>
5h	USER_DATA6	User general purpose data register 6	<a href="#">Go</a>
6h	USER_DATA7	User general purpose data register 7	<a href="#">Go</a>
7h	USER_DATA8	User general purpose data register 8	<a href="#">Go</a>
8h	USER_DATA9	User general purpose data register 9	<a href="#">Go</a>
9h	USER_DATA10	User general purpose data register 10	<a href="#">Go</a>
Ah	USER_DATA11	User general purpose data register 11	<a href="#">Go</a>
Bh	USER_DATA12	User general purpose data register 12	<a href="#">Go</a>
Ch	USER_DATA13	User general purpose data register 13	<a href="#">Go</a>

**Table 7. REGMAP Registers (continued)**

Offset	Acronym	Register Name	Section
Dh	USER_DATA14	User general purpose data register 14	<a href="#">Go</a>
Eh	USER_DATA15	User general purpose data register 15	<a href="#">Go</a>
Fh	USER_DATA16	User general purpose data register 16	<a href="#">Go</a>
10h	USER_DATA17	User general purpose data register 17	<a href="#">Go</a>
11h	USER_DATA18	User general purpose data register 18	<a href="#">Go</a>
12h	USER_DATA19	User general purpose data register 19	<a href="#">Go</a>
13h	USER_DATA20	User general purpose data register 20	<a href="#">Go</a>
14h	TVGAIN0	Time-varying gain map segment configuration register 0	<a href="#">Go</a>
15h	TVGAIN1	Time-varying gain map segment configuration register 1	<a href="#">Go</a>
16h	TVGAIN2	Time-varying gain map segment configuration register 2	<a href="#">Go</a>
17h	TVGAIN3	Time-varying gain map segment configuration register 3	<a href="#">Go</a>
18h	TVGAIN4	Time-varying gain map segment configuration register 4	<a href="#">Go</a>
19h	TVGAIN5	Time-varying gain map segment configuration register 5	<a href="#">Go</a>
1Ah	TVGAIN6	Time-varying gain map segment configuration register 6	<a href="#">Go</a>
1Bh	INIT_GAIN	AFE initial gain configuration register	<a href="#">Go</a>
1Ch	FREQUENCY	Burst frequency configuration register	<a href="#">Go</a>
1Dh	DEADTIME	Deadtime and threshold deglitch configuration	<a href="#">Go</a>
1Eh	PULSE_P1	Preset1 pulse burst, IO control and UART diagnostic configuration	<a href="#">Go</a>
1Fh	PULSE_P2	Preset2 pulse burst, IO control and UART diagnostic configuration	<a href="#">Go</a>
20h	CURR_LIM_P1	Preset1 driver current limit configuration	<a href="#">Go</a>
21h	CURR_LIM_P2	Preset2 current limit and low pass filter configuration	<a href="#">Go</a>
22h	REC_LENGTH	Echo data record period configuration register	<a href="#">Go</a>
23h	FREQ_DIAG	Frequency diagnostic configuration register	<a href="#">Go</a>
24h	SAT_FDIAG_TH	Decay saturation, frequency diag error and Preset1 non-linear control configuration	<a href="#">Go</a>
25h	FVOLT_DEC	Voltage thresholds and Preset2 non-linear scaling configuration	<a href="#">Go</a>
26h	DECPL_TEMP	De-couple temp and AFE gain range configuration	<a href="#">Go</a>
27h	DSP_SCALE	DSP path non-linear scaling and noise level configuration	<a href="#">Go</a>
28h	TEMP_TRIM	Temperature compensation values register	<a href="#">Go</a>
29h	P1_GAIN_CTRL	Preset1 digital gain configuration register	<a href="#">Go</a>
2Ah	P2_GAIN_CTRL	Preset2 digital gain configuration register	<a href="#">Go</a>
2Bh	EE_CRC	User EEPROM space CRC value register	<a href="#">Go</a>
40h	EE_CNTRL	User EEPROM control register	<a href="#">Go</a>
41h	BPF_A2_MSB	BPF A2 coefficient most-significant byte configuration	<a href="#">Go</a>
42h	BPF_A2_LSB	BPF A2 coefficient least-significant byte configuration	<a href="#">Go</a>
43h	BPF_A3_MSB	BPF A3 coefficient most-significant byte configuration	<a href="#">Go</a>
44h	BPF_A3_LSB	BPF A3 coefficient least-significant byte configuration	<a href="#">Go</a>
45h	BPF_B1_MSB	BPF B1 coefficient most-significant byte configuration	<a href="#">Go</a>
46h	BPF_B1_LSB	BPF B1 coefficient least-significant byte configuration	<a href="#">Go</a>
47h	LPF_A2_MSB	LPF A2 coefficient most-significant byte configuration	<a href="#">Go</a>
48h	LPF_A2_LSB	LPF A2 coefficient least-significant byte configuration	<a href="#">Go</a>
49h	LPF_B1_MSB	LPF B1 coefficient most-significant byte configuration	<a href="#">Go</a>
4Ah	LPF_B1_LSB	LPF B1 coefficient least-significant byte configuration	<a href="#">Go</a>
4Bh	TEST_MUX	Test multiplexer configuration register	<a href="#">Go</a>
4Ch	DEV_STAT0	Device Status register 0	<a href="#">Go</a>

**Table 7. REGMAP Registers (continued)**

Offset	Acronym	Register Name	Section
4Dh	DEV_STAT1	Device status register 1	<a href="#">Go</a>
5Fh	P1_THR_0	Preset1 threshold map segment configuration register 0	<a href="#">Go</a>
60h	P1_THR_1	Preset1 threshold map segment configuration register 1	<a href="#">Go</a>
61h	P1_THR_2	Preset1 threshold map segment configuration register 2	<a href="#">Go</a>
62h	P1_THR_3	Preset1 threshold map segment configuration register 3	<a href="#">Go</a>
63h	P1_THR_4	Preset1 threshold map segment configuration register 4	<a href="#">Go</a>
64h	P1_THR_5	Preset1 threshold map segment configuration register 5	<a href="#">Go</a>
65h	P1_THR_6	Preset1 threshold map segment configuration register 6	<a href="#">Go</a>
66h	P1_THR_7	Preset1 threshold map segment configuration register 7	<a href="#">Go</a>
67h	P1_THR_8	Preset1 threshold map segment configuration register 8	<a href="#">Go</a>
68h	P1_THR_9	Preset1 threshold map segment configuration register 9	<a href="#">Go</a>
69h	P1_THR_10	Preset1 threshold map segment configuration register 10	<a href="#">Go</a>
6Ah	P1_THR_11	Preset1 threshold map segment configuration register 11	<a href="#">Go</a>
6Bh	P1_THR_12	Preset1 threshold map segment configuration register 12	<a href="#">Go</a>
6Ch	P1_THR_13	Preset1 threshold map segment configuration register 13	<a href="#">Go</a>
6Dh	P1_THR_14	Preset1 threshold map segment configuration register 14	<a href="#">Go</a>
6Eh	P1_THR_15	Preset1 threshold map segment configuration register 15	<a href="#">Go</a>
6Fh	P2_THR_0	Preset2 threshold map segment configuration register 0	<a href="#">Go</a>
70h	P2_THR_1	Preset2 threshold map segment configuration register 1	<a href="#">Go</a>
71h	P2_THR_2	Preset2 threshold map segment configuration register 2	<a href="#">Go</a>
72h	P2_THR_3	Preset2 threshold map segment configuration register 3	<a href="#">Go</a>
73h	P2_THR_4	Preset2 threshold map segment configuration register 4	<a href="#">Go</a>
74h	P2_THR_5	Preset2 threshold map segment configuration register 5	<a href="#">Go</a>
75h	P2_THR_6	Preset2 threshold map segment configuration register 6	<a href="#">Go</a>
76h	P2_THR_7	Preset2 threshold map segment configuration register 7	<a href="#">Go</a>
77h	P2_THR_8	Preset2 threshold map segment configuration register 8	<a href="#">Go</a>
78h	P2_THR_9	Preset2 threshold map segment configuration register 9	<a href="#">Go</a>
79h	P2_THR_10	Preset2 threshold map segment configuration register 10	<a href="#">Go</a>
7Ah	P2_THR_11	Preset2 threshold map segment configuration register 11	<a href="#">Go</a>
7Bh	P2_THR_12	Preset2 threshold map segment configuration register 12	<a href="#">Go</a>
7Ch	P2_THR_13	Preset2 threshold map segment configuration register 13	<a href="#">Go</a>
7Dh	P2_THR_14	Preset2 threshold map segment configuration register 14	<a href="#">Go</a>
7Eh	P2_THR_15	Preset2 threshold map segment configuration register 15	<a href="#">Go</a>
7Fh	THR_CRC	Threshold map configuration registers data CRC register	<a href="#">Go</a>

Complex bit access types are encoded to fit into small table cells. [Table 8](#) shows the codes that are used for access types in this section.

**Table 8. REGMAP Access Type Codes**

Access Type	Code	Description
<b>Read Type</b>		
R	R	Read
RC	C R	to Clear Read
RH	H R	Set or cleared by hardware Read
<b>Write Type</b>		
W	W	Write

**Table 8. REGMAP Access Type Codes (continued)**

Access Type	Code	Description
Reset or Default Value		
-n		Value after reset or the default value

**7.6.3.1 USER\_DATA1 Register (Address = 0h) [reset = 0h]**

 USER\_DATA1 is shown in [Figure 45](#) and described in [Table 9](#).

 Return to [Summary Table](#).

User general purpose data register 1

**Figure 45. USER\_DATA1 Register**

7	6	5	4	3	2	1	0
USER_1							
R/W-0h							

**Table 9. USER\_DATA1 Register Field Descriptions**

Bit	Field	Type	Reset	Description
7:0	USER_1	R/W	0h	This register has no internal functional use. Register content is User defined solely for external use .

**7.6.3.2 USER\_DATA2 Register (Address = 1h) [reset = 0h]**

 USER\_DATA2 is shown in [Figure 46](#) and described in [Table 10](#).

 Return to [Summary Table](#).

User general purpose data register 2

**Figure 46. USER\_DATA2 Register**

7	6	5	4	3	2	1	0
USER_2							
R/W-0h							

**Table 10. USER\_DATA2 Register Field Descriptions**

Bit	Field	Type	Reset	Description
7:0	USER_2	R/W	0h	This register has no internal functional use. Register content is User defined solely for external use .

**7.6.3.3 USER\_DATA3 Register (Address = 2h) [reset = 0h]**

 USER\_DATA3 is shown in [Figure 47](#) and described in [Table 11](#).

 Return to [Summary Table](#).

User general purpose data register 3

**Figure 47. USER\_DATA3 Register**

7	6	5	4	3	2	1	0
USER_3							
R/W-0h							

**Table 11. USER\_DATA3 Register Field Descriptions**

Bit	Field	Type	Reset	Description
7:0	USER_3	R/W	0h	This register has no internal functional use. Register content is User defined solely for external use .

**7.6.3.4 USER\_DATA4 Register (Address = 3h) [reset = 0h]**

USER\_DATA4 is shown in [Figure 48](#) and described in [Table 12](#).

Return to [Summary Table](#).

User general purpose data register 4

**Figure 48. USER\_DATA4 Register**

7	6	5	4	3	2	1	0
USER_4							
R/W-0h							

**Table 12. USER\_DATA4 Register Field Descriptions**

Bit	Field	Type	Reset	Description
7:0	USER_4	R/W	0h	This register has no internal functional use. Register content is User defined solely for external use .

**7.6.3.5 USER\_DATA5 Register (Address = 4h) [reset = 0h]**

USER\_DATA5 is shown in [Figure 49](#) and described in [Table 13](#).

Return to [Summary Table](#).

User general purpose data register 5

**Figure 49. USER\_DATA5 Register**

7	6	5	4	3	2	1	0
USER_5							
R/W-0h							

**Table 13. USER\_DATA5 Register Field Descriptions**

Bit	Field	Type	Reset	Description
7:0	USER_5	R/W	0h	This register has no internal functional use. Register content is User defined solely for external use .

**7.6.3.6 USER\_DATA6 Register (Address = 5h) [reset = 0h]**

USER\_DATA6 is shown in [Figure 50](#) and described in [Table 14](#).

Return to [Summary Table](#).

User general purpose data register 6

**Figure 50. USER\_DATA6 Register**

7	6	5	4	3	2	1	0
USER_6							
R/W-0h							

**Table 14. USER\_DATA6 Register Field Descriptions**

Bit	Field	Type	Reset	Description
7:0	USER_6	R/W	0h	This register has no internal functional use. Register content is User defined solely for external use .

**7.6.3.7 USER\_DATA7 Register (Address = 6h) [reset = 0h]**

 USER\_DATA7 is shown in [Figure 51](#) and described in [Table 15](#).

 Return to [Summary Table](#).

User general purpose data register 7

**Figure 51. USER\_DATA7 Register**

7	6	5	4	3	2	1	0
USER_7							
R/W-0h							

**Table 15. USER\_DATA7 Register Field Descriptions**

Bit	Field	Type	Reset	Description
7:0	USER_7	R/W	0h	This register has no internal functional use. Register content is User defined solely for external use .

**7.6.3.8 USER\_DATA8 Register (Address = 7h) [reset = 0h]**

 USER\_DATA8 is shown in [Figure 52](#) and described in [Table 16](#).

 Return to [Summary Table](#).

User general purpose data register 8

**Figure 52. USER\_DATA8 Register**

7	6	5	4	3	2	1	0
USER_8							
R/W-0h							

**Table 16. USER\_DATA8 Register Field Descriptions**

Bit	Field	Type	Reset	Description
7:0	USER_8	R/W	0h	This register has no internal functional use. Register content is User defined solely for external use .

**7.6.3.9 USER\_DATA9 Register (Address = 8h) [reset = 0h]**

 USER\_DATA9 is shown in [Figure 53](#) and described in [Table 17](#).

 Return to [Summary Table](#).

User general purpose data register 9

**Figure 53. USER\_DATA9 Register**

7	6	5	4	3	2	1	0
USER_9							
R/W-0h							

**Table 17. USER\_DATA9 Register Field Descriptions**

Bit	Field	Type	Reset	Description
7:0	USER_9	R/W	0h	This register has no internal functional use. Register content is User defined solely for external use .

**7.6.3.10 USER\_DATA10 Register (Address = 9h) [reset = 0h]**

USER\_DATA10 is shown in [Figure 54](#) and described in [Table 18](#).

Return to [Summary Table](#).

User general purpose data register 10

**Figure 54. USER\_DATA10 Register**

7	6	5	4	3	2	1	0
USER_10							
R/W-0h							

**Table 18. USER\_DATA10 Register Field Descriptions**

Bit	Field	Type	Reset	Description
7:0	USER_10	R/W	0h	This register has no internal functional use. Register content is User defined solely for external use .

**7.6.3.11 USER\_DATA11 Register (Address = Ah) [reset = 0h]**

USER\_DATA11 is shown in [Figure 55](#) and described in [Table 19](#).

Return to [Summary Table](#).

User general purpose data register 11

**Figure 55. USER\_DATA11 Register**

7	6	5	4	3	2	1	0
USER_11							
R/W-0h							

**Table 19. USER\_DATA11 Register Field Descriptions**

Bit	Field	Type	Reset	Description
7:0	USER_11	R/W	0h	This register has no internal functional use. Register content is User defined solely for external use .

**7.6.3.12 USER\_DATA12 Register (Address = Bh) [reset = 0h]**

USER\_DATA12 is shown in [Figure 56](#) and described in [Table 20](#).

Return to [Summary Table](#).

User general purpose data register 12

**Figure 56. USER\_DATA12 Register**

7	6	5	4	3	2	1	0
USER_12							
R/W-0h							

**Table 20. USER\_DATA12 Register Field Descriptions**

Bit	Field	Type	Reset	Description
7:0	USER_12	R/W	0h	This register has no internal functional use. Register content is User defined solely for external use .

**7.6.3.13 USER\_DATA13 Register (Address = Ch) [reset = 0h]**

 USER\_DATA13 is shown in [Figure 57](#) and described in [Table 21](#).

 Return to [Summary Table](#).

User general purpose data register 13

**Figure 57. USER\_DATA13 Register**

7	6	5	4	3	2	1	0
USER_13							
R/W-0h							

**Table 21. USER\_DATA13 Register Field Descriptions**

Bit	Field	Type	Reset	Description
7:0	USER_13	R/W	0h	This register has no internal functional use. Register content is User defined solely for external use .

**7.6.3.14 USER\_DATA14 Register (Address = Dh) [reset = 0h]**

 USER\_DATA14 is shown in [Figure 58](#) and described in [Table 22](#).

 Return to [Summary Table](#).

User general purpose data register 14

**Figure 58. USER\_DATA14 Register**

7	6	5	4	3	2	1	0
USER_14							
R/W-0h							

**Table 22. USER\_DATA14 Register Field Descriptions**

Bit	Field	Type	Reset	Description
7:0	USER_14	R/W	0h	This register has no internal functional use. Register content is User defined solely for external use .

**7.6.3.15 USER\_DATA15 Register (Address = Eh) [reset = 0h]**

 USER\_DATA15 is shown in [Figure 59](#) and described in [Table 23](#).

 Return to [Summary Table](#).

User general purpose data register 15

**Figure 59. USER\_DATA15 Register**

7	6	5	4	3	2	1	0
USER_15							
R/W-0h							



**Table 23. USER\_DATA15 Register Field Descriptions**

Bit	Field	Type	Reset	Description
7:0	USER_15	R/W	0h	This register has no internal functional use. Register content is User defined solely for external use .

**7.6.3.16 USER\_DATA16 Register (Address = Fh) [reset = 0h]**

USER\_DATA16 is shown in [Figure 60](#) and described in [Table 24](#).

Return to [Summary Table](#).

User general purpose data register 16

**Figure 60. USER\_DATA16 Register**

7	6	5	4	3	2	1	0
USER_16							
R/W-0h							

**Table 24. USER\_DATA16 Register Field Descriptions**

Bit	Field	Type	Reset	Description
7:0	USER_16	R/W	0h	This register has no internal functional use. Register content is User defined solely for external use .

**7.6.3.17 USER\_DATA17 Register (Address = 10h) [reset = 0h]**

USER\_DATA17 is shown in [Figure 61](#) and described in [Table 25](#).

Return to [Summary Table](#).

User general purpose data register 17

**Figure 61. USER\_DATA17 Register**

7	6	5	4	3	2	1	0
USER_17							
R/W-0h							

**Table 25. USER\_DATA17 Register Field Descriptions**

Bit	Field	Type	Reset	Description
7:0	USER_17	R/W	0h	This register has no internal functional use. Register content is User defined solely for external use .

**7.6.3.18 USER\_DATA18 Register (Address = 11h) [reset = 0h]**

USER\_DATA18 is shown in [Figure 62](#) and described in [Table 26](#).

Return to [Summary Table](#).

User general purpose data register 18

**Figure 62. USER\_DATA18 Register**

7	6	5	4	3	2	1	0
USER_18							
R/W-0h							

**Table 26. USER\_DATA18 Register Field Descriptions**

Bit	Field	Type	Reset	Description
7:0	USER_18	R/W	0h	This register has no internal functional use. Register content is User defined solely for external use .

**7.6.3.19 USER\_DATA19 Register (Address = 12h) [reset = 0h]**

 USER\_DATA19 is shown in [Figure 63](#) and described in [Table 27](#).

 Return to [Summary Table](#).

User general purpose data register 19

**Figure 63. USER\_DATA19 Register**

7	6	5	4	3	2	1	0
USER_19							
R/W-0h							

**Table 27. USER\_DATA19 Register Field Descriptions**

Bit	Field	Type	Reset	Description
7:0	USER_19	R/W	0h	This register has no internal functional use. Register content is User defined solely for external use .

**7.6.3.20 USER\_DATA20 Register (Address = 13h) [reset = 0h]**

 USER\_DATA20 is shown in [Figure 64](#) and described in [Table 28](#).

 Return to [Summary Table](#).

User general purpose data register 20

**Figure 64. USER\_DATA20 Register**

7	6	5	4	3	2	1	0
USER_20							
R/W-0h							

**Table 28. USER\_DATA20 Register Field Descriptions**

Bit	Field	Type	Reset	Description
7:0	USER_20	R/W	0h	This register has no internal functional use. Register content is User defined solely for external use .

**7.6.3.21 TVGAIN0 Register (Address = 14h) [reset = 0h]**

 TVGAIN0 is shown in [Figure 65](#) and described in [Table 29](#).

 Return to [Summary Table](#).

Time-varying gain map segment configuration register 0

**Figure 65. TVGAIN0 Register**

7	6	5	4	3	2	1	0
TVG_T0				TVG_T1			
R/W-0h				R/W-0h			

**Table 29. TVGAIN0 Register Field Descriptions**

Bit	Field	Type	Reset	Description
7:4	TVG_T0	R/W	0h	Time varying gain Start time parameter: 0000b = 100 $\mu$ s 0001b = 200 $\mu$ s 0010b = 300 $\mu$ s 0011b = 400 $\mu$ s 0100b = 600 $\mu$ s 0101b = 800 $\mu$ s 0110b = 1000 $\mu$ s 0111b = 1200 $\mu$ s 1000b = 1400 $\mu$ s 1001b = 2000 $\mu$ s 1010b = 2400 $\mu$ s 1011b = 3200 $\mu$ s 1100b = 4000 $\mu$ s 1101b = 5200 $\mu$ s 1110b = 6400 $\mu$ s 1111b = 8000 $\mu$ s
3:0	TVG_T1	R/W	0h	Time Varying Gain T0/T1 Delta Time: 0000b = 100 $\mu$ s 0001b = 200 $\mu$ s 0010b = 300 $\mu$ s 0011b = 400 $\mu$ s 0100b = 600 $\mu$ s 0101b = 800 $\mu$ s 0110b = 1000 $\mu$ s 0111b = 1200 $\mu$ s 1000b = 1400 $\mu$ s 1001b = 2000 $\mu$ s 1010b = 2400 $\mu$ s 1011b = 3200 $\mu$ s 1100b = 4000 $\mu$ s 1101b = 5200 $\mu$ s 1110b = 6400 $\mu$ s 1111b = 8000 $\mu$ s

**7.6.3.22 TVGAIN1 Register (Address = 15h) [reset = 0h]**

TVGAIN1 is shown in [Figure 66](#) and described in [Table 30](#).

Return to [Summary Table](#).

Time-varying gain map segment configuration register 1

**Figure 66. TVGAIN1 Register**

7	6	5	4	3	2	1	0
TVG_T2				TVG_T3			
R/W-0h				R/W-0h			

**Table 30. TVGAIN1 Register Field Descriptions**

Bit	Field	Type	Reset	Description
7:4	TVG_T2	R/W	0h	Time Varying Gain T1/T2 Delta Time: 0000b = 100 $\mu$ s 0001b = 200 $\mu$ s 0010b = 300 $\mu$ s 0011b = 400 $\mu$ s 0100b = 600 $\mu$ s 0101b = 800 $\mu$ s 0110b = 1000 $\mu$ s 0111b = 1200 $\mu$ s 1000b = 1400 $\mu$ s 1001b = 2000 $\mu$ s 1010b = 2400 $\mu$ s 1011b = 3200 $\mu$ s 1100b = 4000 $\mu$ s 1101b = 5200 $\mu$ s 1110b = 6400 $\mu$ s 1111b = 8000 $\mu$ s
3:0	TVG_T3	R/W	0h	Time Varying Gain T2/T3 Delta Time: 0000b = 100 $\mu$ s 0001b = 200 $\mu$ s 0010b = 300 $\mu$ s 0011b = 400 $\mu$ s 0100b = 600 $\mu$ s 0101b = 800 $\mu$ s 0110b = 1000 $\mu$ s 0111b = 1200 $\mu$ s 1000b = 1400 $\mu$ s 1001b = 2000 $\mu$ s 1010b = 2400 $\mu$ s 1011b = 3200 $\mu$ s 1100b = 4000 $\mu$ s 1101b = 5200 $\mu$ s 1110b = 6400 $\mu$ s 1111b = 8000 $\mu$ s

**7.6.3.23 TVGAIN2 Register (Address = 16h) [reset = 0h]**

 TVGAIN2 is shown in [Figure 67](#) and described in [Table 31](#).

 Return to [Summary Table](#).

Time-varying gain map segment configuration register 2

**Figure 67. TVGAIN2 Register**

7	6	5	4	3	2	1	0
TVG_T4				TVG_T5			
R/W-0h				R/W-0h			

**Table 31. TVGAIN2 Register Field Descriptions**

Bit	Field	Type	Reset	Description
7:4	TVG_T4	R/W	0h	Time Varying Gain T3/T4 Delta Time: 0000b = 100 µs 0001b = 200 µs 0010b = 300 µs 0011b = 400 µs 0100b = 600 µs 0101b = 800 µs 0110b = 1000 µs 0111b = 1200 µs 1000b = 1400 µs 1001b = 2000 µs 1010b = 2400 µs 1011b = 3200 µs 1100b = 4000 µs 1101b = 5200 µs 1110b = 6400 µs 1111b = 8000 µs
3:0	TVG_T5	R/W	0h	Time Varying Gain T4/T5 Delta Time: 0000b = 100 µs 0001b = 200 µs 0010b = 300 µs 0011b = 400 µs 0100b = 600 µs 0101b = 800 µs 0110b = 1000 µs 0111b = 1200 µs 1000b = 1400 µs 1001b = 2000 µs 1010b = 2400 µs 1011b = 3200 µs 1100b = 4000 µs 1101b = 5200 µs 1110b = 6400 µs 1111b = 8000 µs

**7.6.3.24 TVGAIN3 Register (Address = 17h) [reset = 0h]**

TVGAIN3 is shown in [Figure 68](#) and described in [Table 32](#).

Return to [Summary Table](#).

Time-varying gain map segment configuration register 3

**Figure 68. TVGAIN3 Register**

7	6	5	4	3	2	1	0
TVG_G1						TVG_G2	
R/W-0h						R/W-0h	

**Table 32. TVGAIN3 Register Field Descriptions**

Bit	Field	Type	Reset	Description
7:2	TVG_G1	R/W	0h	TVG Point 1 Gain Value: Gain = 0.5 * (TVG_G1 + 1) + value(AFE_GAIN_RNG) [dB] Where value(AFE_GAIN_RNG) is the corresponding value in dB for bits set for AFE_GAIN_RNG in DECPL_TEMP register
1:0	TVG_G2	R/W	0h	TVG Point 2 Gain Value: Gain = 0.5 * (TVG_G2 + 1) + value(AFE_GAIN_RNG) [dB] Where value(AFE_GAIN_RNG) is the corresponding value in dB for bits set for AFE_GAIN_RNG in DECPL_TEMP register

**7.6.3.25 TVGAIN4 Register (Address = 18h) [reset = 0h]**

TVGAIN4 is shown in [Figure 69](#) and described in [Table 33](#).

Return to [Summary Table](#).

Time-varying gain map segment configuration register 4

**Figure 69. TVGAIN4 Register**

7	6	5	4	3	2	1	0
TVG_G2				TVG_G3			
R/W-0h				R/W-0h			

**Table 33. TVGAIN4 Register Field Descriptions**

Bit	Field	Type	Reset	Description
7:4	TVG_G2	R/W	0h	TVG Point 2 Gain Value: Gain = 0.5 * (TVG_G2 + 1) + value(AFE_GAIN_RNG) [dB] Where value(AFE_GAIN_RNG) is the corresponding value in dB for bits set for AFE_GAIN_RNG in DECPL_TEMP register
3:0	TVG_G3	R/W	0h	TVG Point 3 Gain Value: Gain = 0.5 * (TVG_G3 + 1) + value(AFE_GAIN_RNG) [dB] Where value(AFE_GAIN_RNG) is the corresponding value in dB for bits set for AFE_GAIN_RNG in DECPL_TEMP register

**7.6.3.26 TVGAIN5 Register (Address = 19h) [reset = 0h]**

TVGAIN5 is shown in [Figure 70](#) and described in [Table 34](#).

Return to [Summary Table](#).

Time-varying gain map segment configuration register 5

**Figure 70. TVGAIN5 Register**

7	6	5	4	3	2	1	0
TVG_G3			TVG_G4				
R/W-0h			R/W-0h				

**Table 34. TVGAIN5 Register Field Descriptions**

Bit	Field	Type	Reset	Description
7:6	TVG_G3	R/W	0h	TVG Point 3 Gain Value: Gain = 0.5 * (TVG_G3 + 1) + value(AFE_GAIN_RNG) [dB] Where value(AFE_GAIN_RNG) is the corresponding value in dB for bits set for AFE_GAIN_RNG in DECPL_TEMP register
5:0	TVG_G4	R/W	0h	TVG Point 4 Gain Value: Gain = 0.5 * (TVG_G4 + 1) + value(AFE_GAIN_RNG) [dB] Where value(AFE_GAIN_RNG) is the corresponding value in dB for bits set for AFE_GAIN_RNG in DECPL_TEMP register

**7.6.3.27 TVGAIN6 Register (Address = 1Ah) [reset = 0h]**

TVGAIN6 is shown in [Figure 71](#) and described in [Table 35](#).

Return to [Summary Table](#).

Time-varying gain map segment configuration register 6

**Figure 71. TVGAIN6 Register**

7	6	5	4	3	2	1	0
TVG_G5						RESERVED	FREQ_SHIFT
R/W-0h						R/W-0h	R/W-0h

**Table 35. TVGAIN6 Register Field Descriptions**

Bit	Field	Type	Reset	Description
7:2	TVG_G5	R/W	0h	TVG Point 5 Gain Value: Gain = $0.5 * (TVG\_G5 + 1) + \text{value}(AFE\_GAIN\_RNG)$ [dB] Where value(AFE_GAIN_RNG) is the corresponding value in dB for bits set for AFE_GAIN_RNG in DECPL_TEMP register
1	RESERVED	R/W	0h	Reserved
0	FREQ_SHIFT	R/W	0h	Burst Frequency Range Shift: 0b = Disabled 1b = Enabled, active frequency = $6 * \text{frequency}$ result from calculation using equation given in the FREQUENCY register

**7.6.3.28 INIT\_GAIN Register (Address = 1Bh) [reset = 0h]**

INIT\_GAIN is shown in [Figure 72](#) and described in [Table 36](#).

Return to [Summary Table](#).

AFE initial gain configuration register

**Figure 72. INIT\_GAIN Register**

7	6	5	4	3	2	1	0
BPF_BW			GAIN_INIT				
R/W-0h			R/W-0h				

**Table 36. INIT\_GAIN Register Field Descriptions**

Bit	Field	Type	Reset	Description
7:6	BPF_BW	R/W	0h	Digital banpass filter bandwidth: BandWidth = $2 * (BPF\_BW + 1)$ [kHz]
5:0	GAIN_INIT	R/W	0h	Initial AFE Gain: Init_Gain = $0.5 * (GAIN\_INIT+1) + \text{value}(AFE\_GAIN\_RNG)$ [dB] Where value(AFE_GAIN_RNG) is the corresponding value in dB for bits set for AFE_GAIN_RNG in DECPL_TEMP register

**7.6.3.29 FREQUENCY Register (Address = 1Ch) [reset = 0h]**

FREQUENCY is shown in [Figure 73](#) and described in [Table 37](#).

Return to [Summary Table](#).

Burst frequency configuration register

**Figure 73. FREQUENCY Register**

7	6	5	4	3	2	1	0
FREQ							
R/W-0h							

**Table 37. FREQUENCY Register Field Descriptions**

Bit	Field	Type	Reset	Description
7:0	FREQ	R/W	0h	Burst frequency equation parameter: Frequency = $0.2 * FREQ + 30$ [kHz] The valid FREQ parameter value range is from 0 to 250 (00h to FAh)

**7.6.3.30 DEADTIME Register (Address = 1Dh) [reset = 0h]**

DEADTIME is shown in [Figure 74](#) and described in [Table 38](#).

Return to [Summary Table](#).

Pulse deadtime and threshold deglitch configuration register

**Figure 74. DEADTIME Register**

7	6	5	4	3	2	1	0
THR_CMP_DEGLTCH				PULSE_DT			
R/W-0h				R/W-0h			

**Table 38. DEADTIME Register Field Descriptions**

Bit	Field	Type	Reset	Description
7:4	THR_CMP_DEGLTCH	R/W	0h	Threshold level comparator deglitch period: deglitch period = (THR_CMP_DEGLTCH * 8) [μs]
3:0	PULSE_DT	R/W	0h	Burst Pulse Dead-Time: DeadTime = 0.0625 * PULSE_DT[μs]

**7.6.3.31 PULSE\_P1 Register (Address = 1Eh) [reset = 0h]**

 PULSE\_P1 is shown in [Figure 75](#) and described in [Table 39](#).

 Return to [Summary Table](#).

Preset1 pulse burst number, IO pin control, and UART diagnostic configuration register

**Figure 75. PULSE\_P1 Register**

7	6	5	4	3	2	1	0
IO_IF_SEL	UART_DIAG	IO_DIS	P1_PULSE				
R/W-0h	R/W-0h	R/W-0h	R/W-0h				

**Table 39. PULSE\_P1 Register Field Descriptions**

Bit	Field	Type	Reset	Description
7	IO_IF_SEL	R/W	0h	Interface Selection on IO pin: 0b = Time-Based Interface 1b = One-Wire UART Interface
6	UART_DIAG	R/W	0h	UART Diagnostic Page Selection: 0b = Diagnostic bits related to UART interface 1b = Diagnostic bits related to System Diagnostics
5	IO_DIS	R/W	0h	Disable IO pin transceiver: 0b = IO transceiver enabled 1b = IO transceiver disabled Note: Available only if IO_IF_SEL = 0
4:0	P1_PULSE	R/W	0h	Number of burst pulses for Preset1 Note: 0h means one pulse is generated on OUTA only

**7.6.3.32 PULSE\_P2 Register (Address = 1Fh) [reset = 0h]**

 PULSE\_P2 is shown in [Figure 76](#) and described in [Table 40](#).

 Return to [Summary Table](#).

Preset2 pulse burst number and UART address configuration register

**Figure 76. PULSE\_P2 Register**

7	6	5	4	3	2	1	0
UART_ADDR				P2_PULSE			
R/W-0h				R/W-0h			



**Table 40. PULSE\_P2 Register Field Descriptions**

Bit	Field	Type	Reset	Description
7:5	UART_ADDR	R/W	0h	UART interface address
4:0	P2_PULSE	R/W	0h	Number of burst pulses for Preset2 Note: 0h means one pulse is generated on OUTA only

**7.6.3.33 CURR\_LIM\_P1 Register (Address = 20h) [reset = 0h]**

CURR\_LIM\_P1 is shown in [Figure 77](#) and described in [Table 41](#).

Return to [Summary Table](#).

Preset1 driver current limit configuration register

**Figure 77. CURR\_LIM\_P1 Register**

7	6	5	4	3	2	1	0
DIS_CL		CURR_LIM1					
R/W-0h		R/W-0h					

**Table 41. CURR\_LIM\_P1 Register Field Descriptions**

Bit	Field	Type	Reset	Description
7	DIS_CL	R/W	0h	Disable Current Limit for Preset1 and Preset2 0b = current limit enabled 1b = current limit disabled
5:0	CURR_LIM1	R/W	0h	Driver Current Limit for Preset1 Current_Limit = 7 * CURR_LIM1 + 50 [mA]

**7.6.3.34 CURR\_LIM\_P2 Register (Address = 21h) [reset = 0h]**

CURR\_LIM\_P2 is shown in [Figure 78](#) and described in [Table 42](#).

Return to [Summary Table](#).

Preset2 current limit and low pass filter configuration register

**Figure 78. CURR\_LIM\_P2 Register**

7	6	5	4	3	2	1	0
LPF_CO		CURR_LIM2					
R/W-0h		R/W-0h					

**Table 42. CURR\_LIM\_P2 Register Field Descriptions**

Bit	Field	Type	Reset	Description
7:6	LPF_CO	R/W	0h	Lowpass filter cutoff frequency: Cut off frequency = LPF_CO + 1 [kHz]
5:0	CURR_LIM2	R/W	0h	Driver current limit for Preset2 Current limit = 7 * CURR_LIM2 + 50 [mA]

**7.6.3.35 REC\_LENGTH Register (Address = 22h) [reset = 0h]**

REC\_LENGTH is shown in [Figure 79](#) and described in [Table 43](#).

Return to [Summary Table](#).

Echo data record period configuration register

**Figure 79. REC\_LENGTH Register**

7	6	5	4	3	2	1	0
P1_REC				P2_REC			
R/W-0h				R/W-0h			

**Table 43. REC\_LENGTH Register Field Descriptions**

Bit	Field	Type	Reset	Description
7:4	P1_REC	R/W	0h	Preset1 record time length: Record time = 4.096 * (P1_REC + 1) [ms]
3:0	P2_REC	R/W	0h	Preset2 record time length: Record time = 4.096 * (P2_REC + 1) [ms]

**7.6.3.36** *FREQ\_DIAG Register (Address = 23h) [reset = 0h]*

 FREQ\_DIAG is shown in [Figure 80](#) and described in [Table 44](#).

 Return to [Summary Table](#).

Frequency diagnostic configuration register

**Figure 80. FREQ\_DIAG Register**

7	6	5	4	3	2	1	0
FDIAG_LEN				FDIAG_START			
R/W-0h				R/W-0h			

**Table 44. FREQ\_DIAG Register Field Descriptions**

Bit	Field	Type	Reset	Description
7:4	FDIAG_LEN	R/W	0h	Frequency diagnostic window length: For value 0h, the diagnostic is disabled. For values 0 to Fh, the window length is given by 3 * FDIAG_LEN [Signal Periods]
3:0	FDIAG_START	R/W	0h	Frequency diagnostic start time: Start time = 100 * FDIAG_START [μs] Note: this time is relative to the end-of-burst time

**7.6.3.37** *SAT\_FDIAG\_TH Register (Address = 24h) [reset = 0h]*

 SAT\_FDIAG\_TH is shown in [Figure 81](#) and described in [Table 45](#).

 Return to [Summary Table](#).

Decay saturation threshold, frequency diagnostic error threshold, and Preset1 non-linear enable control configuration register

**Figure 81. SAT\_FDIAG\_TH Register**

7	6	5	4	3	2	1	0
FDIAG_ERR_TH			SAT_TH			P1_NLS_EN	
R/W-0h			R/W-0h			R/W-0h	

**Table 45. SAT\_FDIAG\_TH Register Field Descriptions**

Bit	Field	Type	Reset	Description
7:5	FDIAG_ERR_TH	R/W	0h	Frequency diagnostic absolute error time threshold: threshold = (FDIAG_ERR_TH + 1) [μs]
4:1	SAT_TH	R/W	0h	Saturation diagnostic threshold level.
0	P1_NLS_EN	R/W	0h	Set high to enable Preset1 non-linear scaling

**7.6.3.38 FVOLT\_DEC Register (Address = 25h) [reset = 0h]**

 FVOLT\_DEC is shown in [Figure 82](#) and described in [Table 46](#).

 Return to [Summary Table](#).

Voltage thresholds and Preset2 non-linear scaling enable configuration register

**Figure 82. FVOLT\_DEC Register**

7	6	5	4	3	2	1	0
P2_NLS_EN	VPWR_OV_TH	LPM_TMR		FVOLT_ERR_TH			
R/W-0h	R/W-0h	R/W-0h		R/W-0h			

**Table 46. FVOLT\_DEC Register Field Descriptions**

Bit	Field	Type	Reset	Description
7	P2_NLS_EN	R/W	0h	Set high to enable Preset2 non-linear scaling
6:5	VPWR_OV_TH	R/W	0h	VPWR over voltage threshold select: 00b = 12.3 V 01b = 17.7 V 10b = 22.8 V 11b = 28.3 V
4:3	LPM_TMR	R/W	0h	Low power mode enter time: 00b = 250 ms 01b = 500 ms 10b = 1 s 11b = 4s
2:0	FVOLT_ERR_TH	R/W	0h	See section on System Diagnostics for Voltage diagnostic measurement: 000b = 1 001b = 2 010b = 3 011b = 4 100b = 5 101b = 6 110b = 7 111b = 8

**7.6.3.39 DECPL\_TEMP Register (Address = 26h) [reset = 0h]**

 DECPL\_TEMP is shown in [Figure 83](#) and described in [Table 47](#).

 Return to [Summary Table](#).

De-couple temperature and AFE gain range configuration register

**Figure 83. DECPL\_TEMP Register**

7	6	5	4	3	2	1	0
AFE_GAIN_RNG	LPM_EN	DECPL_TEMP_SEL	DECPL_T				
R/W-0h	R/W-0h	R/W-0h	R/W-0h				

**Table 47. DECPL\_TEMP Register Field Descriptions**

Bit	Field	Type	Reset	Description
7:6	AFE_GAIN_RNG	R/W	0h	AFE gain range selection codes: 00b = 58 to 90 dB 01b = 52 to 84 dB 10b = 46 to 78 dB 11b = 32 to 64 dB

**Table 47. DECPL\_TEMP Register Field Descriptions (continued)**

Bit	Field	Type	Reset	Description
5	LPM_EN	R/W	0h	PGA460 Low Power Mode Enable: 0b = Low power mode is disabled 1b = Low power mode is enabled
4	DECPL_TEMP_SEL	R/W	0h	Decouple Time / Temperature Select: 0b = Time Decouple 1b = Temperature Decouple
3:0	DECPL_T	R/W	0h	Secondary decouple time / temperature decouple If DECPL_TEMP_SEL = 0 (Time Decouple) Time = 4096 * (DECPL_T + 1) [μs] If DECPL_TEMP_SEL = 1 (Temperature Decouple) Temperature = 10 * DECPL_T - 40 [degC]

**7.6.3.40 DSP\_SCALE Register (Address = 27h) [reset = 0h]**

 DSP\_SCALE is shown in [Figure 84](#) and described in [Table 48](#).

 Return to [Summary Table](#).

DSP non-linear scaling and noise level configuration register

**Figure 84. DSP\_SCALE Register**

7	6	5	4	3	2	1	0
NOISE_LVL				SCALE_K		SCALE_N	
R/W-0h				R/W-0h		R/W-0h	

**Table 48. DSP\_SCALE Register Field Descriptions**

Bit	Field	Type	Reset	Description
7:3	NOISE_LVL	R/W	0h	Value ranges from 0 to 31 with 1 LSB steps for digital gain values (Px_DIG_GAIN_LR) less than 8 If digital gain (Px_DIG_GAIN_LR) is larger than 8, then multiply the NOISE_LVL by Px_DIG_GAIN_LR/8
2	SCALE_K	R/W	0h	Non-Linear scaling exponent selection: 0b = 1.50 1b = 2.00
1:0	SCALE_N	R/W	0h	Selects the starting threshold level point from which the non-linear gain (if enabled) is applied: 00b = TH9 01b = TH10 10b = TH11 11b = TH12

**7.6.3.41 TEMP\_TRIM Register (Address = 28h) [reset = 0h]**

 TEMP\_TRIM is shown in [Figure 85](#) and described in [Table 49](#).

 Return to [Summary Table](#).

Temperature sensor compensation values register

**Figure 85. TEMP\_TRIM Register**

7	6	5	4	3	2	1	0
TEMP_GAIN				TEMP_OFF			
R/W-0h				R/W-0h			

**Table 49. TEMP\_TRIM Register Field Descriptions**

Bit	Field	Type	Reset	Description
7:4	TEMP_GAIN	R/W	0h	Temperature scaling gain: signed value can range from -8 (1000b) to 7 (0111b) used for measured temperature value compensation
3:0	TEMP_OFF	R/W	0h	Temperature Scaling Offset: signed value can range from -8 (1000b) to 7 (0111b) used for measured temperature value compensation

**7.6.3.42 P1\_GAIN\_CTRL Register (Address = 29h) [reset = 0h]**

P1\_GAIN\_CTRL is shown in [Figure 86](#) and described in [Table 50](#).

Return to [Summary Table](#).

Preset1 digital gain configuration register

**Figure 86. P1\_GAIN\_CTRL Register**

7	6	5	4	3	2	1	0
P1_DIG_GAIN_LR_ST		P1_DIG_GAIN_LR			P1_DIG_GAIN_SR		
R/W-0h		R/W-0h			R/W-0h		

**Table 50. P1\_GAIN\_CTRL Register Field Descriptions**

Bit	Field	Type	Reset	Description
7:6	P1_DIG_GAIN_LR_ST	R/W	0h	Selects the starting Preset1 threshold level point from which the long range (LR) digital gain, P1_DIG_GAIN_LR, is applied 00b = TH9 01b = TH10 10b = TH11 11b = TH12
5:3	P1_DIG_GAIN_LR	R/W	0h	Preset1 Digital long range (LR) gain applied from the selected long range threshold level point to the end of the record period Applied to the thresholds set by P1_DIG_GAIN_LR_ST: 000b = multiplied by 1 001b = multiplied by 2 010b = multiplied by 4 011b = multiplied by 8 100b = multiplied by 16 101b = multiplied by 32 110b = invalid 111b = invalid
2:0	P1_DIG_GAIN_SR	R/W	0h	Preset1 Digital short range (SR) gain applied from time zero to the start of the selected long range (LR) threshold level point: 000b = multiplied by 1 001b = multiplied by 2 010b = multiplied by 4 011b = multiplied by 8 100b = multiplied by 16 101b = multiplied by 32 110b = invalid 111b = invalid

**7.6.3.43 P2\_GAIN\_CTRL Register (Address = 2Ah) [reset = 0h]**

P2\_GAIN\_CTRL is shown in [Figure 87](#) and described in [Table 51](#).

Return to [Summary Table](#).

Preset2 digital gain configuration register

**Figure 87. P2\_GAIN\_CTRL Register**

7	6	5	4	3	2	1	0
P2_DIG_GAIN_LR_ST		P2_DIG_GAIN_LR			P2_DIG_GAIN_SR		
R/W-0h		R/W-0h			R/W-0h		

**Table 51. P2\_GAIN\_CTRL Register Field Descriptions**

Bit	Field	Type	Reset	Description
7:6	P2_DIG_GAIN_LR_ST	R/W	0h	Selects the starting Preset2 threshold level point from which the long range (LR) digital gain, P2_DIG_GAIN_LR, is applied 00b = TH9 01b = TH10 10b = TH11 11b = TH12
5:3	P2_DIG_GAIN_LR	R/W	0h	Preset2 Digital long range (LR) gain applied from the selected long range threshold level point to the end of the record period Applied to the thresholds set by P2_DIG_GAIN_LR_ST: 000b = multiplied by 1 001b = multiplied by 2 010b = multiplied by 4 011b = multiplied by 8 100b = multiplied by 16 101b = multiplied by 32 110b = invalid 111b = invalid
2:0	P2_DIG_GAIN_SR	R/W	0h	Preset2 Digital short range (SR) gain applied from time zero to the start of the selected long range (LR) threshold level point: 000b = multiplied by 1 001b = multiplied by 2 010b = multiplied by 4 011b = multiplied by 8 100b = multiplied by 16 101b = multiplied by 32 110b = invalid 111b = invalid

#### 7.6.3.44 EE\_CRC Register (Address = 2Bh) [reset = 0h]

EE\_CRC is shown in [Figure 88](#) and described in [Table 52](#).

Return to [Summary Table](#).

User EEPROM space data CRC register

**Figure 88. EE\_CRC Register**

7	6	5	4	3	2	1	0
EE_CRC							
R/W-0h							

**Table 52. EE\_CRC Register Field Descriptions**

Bit	Field	Type	Reset	Description
7:0	EE_CRC	R/W	0h	User EEPROM space data CRC value

#### 7.6.3.45 EE\_CNTRL Register (Address = 40h) [reset = 00h]

EE\_CNTRL is shown in [Figure 89](#) and described in [Table 53](#).

Return to [Summary Table](#).

User EEPROM control register

**Figure 89. EE\_CNTRL Register**

7	6	5	4	3	2	1	0
DATADUMP_EN	EE_UNLCK			EE_PRGM_OK	EE_RLOAD	EE_PRGM	
RH/W-0h	R/W-0h			R-0h	R/W-0h	R/W-0h	

**Table 53. EE\_CNTRL Register Field Descriptions**

Bit	Field	Type	Reset	Description
7	DATADUMP_EN	RH/W	0h	Data Dump Enable bit: 0b = Disabled 1b = Enabled
6:3	EE_UNLCK	R/W	0h	EEPROM program enable unlock passcode register: The valid passcode for enabling EEPROM programming is 0xD.
2	EE_PRGM_OK	R	0h	EEPROM programming status: 0b = EEPROM was not programmed successfully 1b = EEPROM was programmed successfully
1	EE_RLOAD	R/W	0h	EEPROM Reload Trigger: 0b = Disabled 1b = Reload Data from EEPROM
0	EE_PRGM	R/W	0h	EEPROM Program Trigger: 0b = Disabled 1b = Program Data to EEPROM

**7.6.3.46 BPF\_A2\_MSB Register (Address = 41h) [reset = 00h]**

BPF\_A2\_MSB is shown in [Figure 90](#) and described in [Table 54](#).

Return to [Summary Table](#).

BPF A2 coefficient most-significant byte configuration

**Figure 90. BPF\_A2\_MSB Register**

7	6	5	4	3	2	1	0
BPF_A2_MSB							
R/W-0h							

**Table 54. BPF\_A2\_MSB Register Field Descriptions**

Bit	Field	Type	Reset	Description
7:0	BPF_A2_MSB	R/W	0h	Bandpass filter A2 coefficient most-significant byte value

**7.6.3.47 BPF\_A2\_LSB Register (Address = 42h) [reset = 00h]**

BPF\_A2\_LSB is shown in [Figure 91](#) and described in [Table 55](#).

Return to [Summary Table](#).

BPF A2 coefficient least-significant byte configuration

**Figure 91. BPF\_A2\_LSB Register**

7	6	5	4	3	2	1	0
BPF_A2_LSB							
R/W-0h							

**Table 55. BPF\_A2\_LSB Register Field Descriptions**

Bit	Field	Type	Reset	Description
7:0	BPF_A2_LSB	R/W	0h	Bandpass filter A2 coefficient least-significant byte value

**7.6.3.48 BPF\_A3\_MSB Register (Address = 43h) [reset = 00h]**

 BPF\_A3\_MSB is shown in [Figure 92](#) and described in [Table 56](#).

 Return to [Summary Table](#).

BPF A3 coefficient most-significant byte configuration

**Figure 92. BPF\_A3\_MSB Register**

7	6	5	4	3	2	1	0
BPF_A3_MSB							
R/W-0h							

**Table 56. BPF\_A3\_MSB Register Field Descriptions**

Bit	Field	Type	Reset	Description
7:0	BPF_A3_MSB	R/W	0h	Bandpass filter A3 coefficient most-significant byte value

**7.6.3.49 BPF\_A3\_LSB Register (Address = 44h) [reset = 00h]**

 BPF\_A3\_LSB is shown in [Figure 93](#) and described in [Table 57](#).

 Return to [Summary Table](#).

BPF A3 coefficient least-significant byte configuration

**Figure 93. BPF\_A3\_LSB Register**

7	6	5	4	3	2	1	0
BPF_A3_LSB							
R/W-0h							

**Table 57. BPF\_A3\_LSB Register Field Descriptions**

Bit	Field	Type	Reset	Description
7:0	BPF_A3_LSB	R/W	0h	Bandpass filter A3 coefficient least-significant byte value

**7.6.3.50 BPF\_B1\_MSB Register (Address = 45h) [reset = 00h]**

 BPF\_B1\_MSB is shown in [Figure 94](#) and described in [Table 58](#).

 Return to [Summary Table](#).

BPF B1 coefficient most-significant byte configuration

**Figure 94. BPF\_B1\_MSB Register**

7	6	5	4	3	2	1	0
BPF_B1_MSB							
R/W-0h							

**Table 58. BPF\_B1\_MSB Register Field Descriptions**

Bit	Field	Type	Reset	Description
7:0	BPF_B1_MSB	R/W	0h	Bandpass filter B1 coefficient most-significant byte value

**7.6.3.51 BPF\_B1\_LSB Register (Address = 46h) [reset = 00h]**

 BPF\_B1\_LSB is shown in [Figure 95](#) and described in [Table 59](#).

 Return to [Summary Table](#).

BPF B1 coefficient least-significant byte configuration



**Figure 95. BPF\_B1\_LSB Register**

7	6	5	4	3	2	1	0
BPF_B1_LSB							
R/W-0h							

**Table 59. BPF\_B1\_LSB Register Field Descriptions**

Bit	Field	Type	Reset	Description
7:0	BPF_B1_LSB	R/W	0h	Bandpass filter B1 coefficient least-significant byte value

**7.6.3.52 LPF\_A2\_MSB Register (Address = 47h) [reset = 00h]**

LPF\_A2\_MSB is shown in [Figure 96](#) and described in [Table 60](#).

Return to [Summary Table](#).

LPF A2 coefficient most-significant byte configuration

**Figure 96. LPF\_A2\_MSB Register**

7	6	5	4	3	2	1	0
RESERVED							LPF_A2_MSB
R-0h							R/W-0h

**Table 60. LPF\_A2\_MSB Register Field Descriptions**

Bit	Field	Type	Reset	Description
7	RESERVED	R	0h	Reserved
6:0	LPF_A2_MSB	R/W	0h	Lowpass filter A2 coefficient most-significant byte value

**7.6.3.53 LPF\_A2\_LSB Register (Address = 48h) [reset = 00h]**

LPF\_A2\_LSB is shown in [Figure 97](#) and described in [Table 61](#).

Return to [Summary Table](#).

LPF A2 coefficient least-significant byte configuration

**Figure 97. LPF\_A2\_LSB Register**

7	6	5	4	3	2	1	0
LPF_A2_LSB							
R/W-0h							

**Table 61. LPF\_A2\_LSB Register Field Descriptions**

Bit	Field	Type	Reset	Description
7:0	LPF_A2_LSB	R/W	0h	Lowpass filter A2 coefficient least-significant byte value

**7.6.3.54 LPF\_B1\_MSB Register (Address = 49h) [reset = 00h]**

LPF\_B1\_MSB is shown in [Figure 98](#) and described in [Table 62](#).

Return to [Summary Table](#).

LPF B1 coefficient most-significant byte configuration

**Figure 98. LPF\_B1\_MSB Register**

7	6	5	4	3	2	1	0
RESERVED							LPF_B1_MSB
R-0h							R/W-0h

**Table 62. LPF\_B1\_MSB Register Field Descriptions**

Bit	Field	Type	Reset	Description
7	RESERVED	R	0h	Reserved
6:0	LPF_B1_MSB	R/W	0h	Lowpass filter B1 coefficient most-significant byte value

**7.6.3.55 LPF\_B1\_LSB Register (Address = 4Ah) [reset = 00h]**

 LPF\_B1\_LSB is shown in [Figure 99](#) and described in [Table 63](#).

 Return to [Summary Table](#).

LPF B1 coefficient least-significant byte configuration

**Figure 99. LPF\_B1\_LSB Register**

7	6	5	4	3	2	1	0
LPF_B1_LSB							
R/W-0h							

**Table 63. LPF\_B1\_LSB Register Field Descriptions**

Bit	Field	Type	Reset	Description
7:0	LPF_B1_LSB	R/W	0h	Lowpass filter B1 coefficient least-significant byte value

**7.6.3.56 TEST\_MUX Register (Address = 4Bh) [reset = 00h]**

 TEST\_MUX is shown in [Figure 100](#) and described in [Table 64](#).

 Return to [Summary Table](#).

Test multiplexers configuration register

**Figure 100. TEST\_MUX Register**

7	6	5	4	3	2	1	0
TEST_MUX			RESERVED	SAMPLE_SEL	DP_MUX		
R/W-0h			R-0h	R/W-0h	R/W-0h		

**Table 64. TEST\_MUX Register Field Descriptions**

Bit	Field	Type	Reset	Description
7:5	TEST_MUX	R/W	0h	Multiplexer output on the TEST Pin: 000b = GND ("Mux Off") 001b = Analog Front End output 010b = Reserved 011b = Reserved 100b = 8MHz clock 101b = ADC sample output clock 110b = Reserved 111b = Reserved Note 1 000b through 011b are analog output signals Note 2 100b through 111b are digital output signals
4	RESERVED	R	0h	Reserved
3	SAMPLE_SEL	R/W	0h	Data path sample select: 0b = 8 bit sample output at 1 $\mu$ s per sample 1b = 12 bit sample output at 2 $\mu$ s per sample Note: For use with DP_MUX parameter values 001b to 100b

**Table 64. TEST\_MUX Register Field Descriptions (continued)**

Bit	Field	Type	Reset	Description
2:0	DP_MUX	R/W	0h	Data path multiplexer source select codes: 000b = Disabled 001b = LPF output 010b = Rectifier output 011b = BPF output 100b = ADC output 101b = Not used 110b = Not used 111b = Not used

**7.6.3.57 DEV\_STAT0 Register (Address = 4Ch) [reset = 84h]**

DEV\_STAT0 is shown in [Figure 101](#) and described in [Table 65](#).

Return to [Summary Table](#).

Device Status register 0

**Figure 101. DEV\_STAT0 Register**

7	6	5	4	3	2	1	0
REV_ID	OPT_ID		CMW_WU_ER	THR_CRC_ER	EE_CRC_ERR	TRIM_CRC_ER	
R-2h	R-0h		R	R	R-0h	R	R-0h

**Table 65. DEV\_STAT0 Register Field Descriptions**

Bit	Field	Type	Reset	Description
7:6	REV_ID	R	2h	Device Revision Identification
5:4	OPT_ID	R	0h	Device Option Identification
3	CMW_WU_ERR	R	0h	Wakeup Error indicator: 0 = no error 1 = user tried to send a command before the wake up sequence is done
2	THR_CRC_ERR	R	1h	Threshold map configuration register data CRC error status: 0 = No error 1 = CRC error detected This flag is asserted upon device power-up to indicate the uninitialized state of the threshold map configuration registers.
1	EE_CRC_ERR	R	0h	User EEPROM space data CRC error status: 0 = No error 1 = CRC error detected
0	TRIM_CRC_ERR	R	0h	Trim EEPROM space data CRC error status: 0 = No error 1 = CRC error detected

**7.6.3.58 DEV\_STAT1 Register (Address = 4Dh) [reset = 00h]**

DEV\_STAT1 is shown in [Figure 102](#) and described in [Table 66](#).

Return to [Summary Table](#).

Device status register 1

**Figure 102. DEV\_STAT1 Register**

7	6	5	4	3	2	1	0
RESERVED	TSD_PROT	IOREG_OV	IOREG_UV	AVDD_OV	AVDD_UV	VPWR_OV	VPWR_UV
R-0h	RC-0h	RC-0h	RC-0h	RC-0h	RC-0h	RC-0h	RC-0h

**Table 66. DEV\_STAT1 Register Field Descriptions**

Bit	Field	Type	Reset	Description
7	RESERVED	R	0h	Reserved
6	TSD_PROT	RC	0h	Thermal shut-down protection status: 0 = No thermal shutdown has occurred 1 = Thermal shutdown has occurred
5	IOREG_OV	RC	0h	IOREG pin over voltage status: 0 = No error 1 = IOREG over voltage error
4	IOREG_UV	RC	0h	IOREG pin under voltage status: 0 = No error 1 = IOREG under voltage error
3	AVDD_OV	RC	0h	AVDD pin over voltage status: 0 = No error 1 = AVDD over voltage error
2	AVDD_UV	RC	0h	AVDD pin under voltage status: 0 = No Error 1 = AVDD Under voltage error
1	VPWR_OV	RC	0h	VPWR pin over voltage status: 0 = No error 1 = VPWR over voltage error
0	VPWR_UV	RC	0h	VPWR pin under voltage status: 0 = No error 1 = VPWR under voltage Error

**7.6.3.59 P1\_THR\_0 Register (Address = 5Fh) [reset = X]**

 P1\_THR\_0 is shown in [Figure 103](#) and described in [Table 67](#).

 Return to [Summary Table](#).

Preset1 threshold map segment configuration register 0

**Figure 103. P1\_THR\_0 Register**

7	6	5	4	3	2	1	0
TH_P1_T1				TH_P1_T2			
R/W-X				R/W-X			

**Table 67. P1\_THR\_0 Register Field Descriptions**

Bit	Field	Type	Reset	Description
7:4	TH_P1_T1	R/W	X	Preset1 Threshold T1 absolute time: 0000b = 100 $\mu$ s 0001b = 200 $\mu$ s 0010b = 300 $\mu$ s 0011b = 400 $\mu$ s 0100b = 600 $\mu$ s 0101b = 800 $\mu$ s 0110b = 1000 $\mu$ s 0111b = 1200 $\mu$ s 1000b = 1400 $\mu$ s 1001b = 2000 $\mu$ s 1010b = 2400 $\mu$ s 1011b = 3200 $\mu$ s 1100b = 4000 $\mu$ s 1101b = 5200 $\mu$ s 1110b = 6400 $\mu$ s 1111b = 8000 $\mu$ s This bit-field powers-up un-initialized.

**Table 67. P1\_THR\_0 Register Field Descriptions (continued)**

Bit	Field	Type	Reset	Description
3:0	TH_P1_T2	R/W	X	Preset1 Threshold T2 delta time: 0000b = 100 $\mu$ s 0001b = 200 $\mu$ s 0010b = 300 $\mu$ s 0011b = 400 $\mu$ s 0100b = 600 $\mu$ s 0101b = 800 $\mu$ s 0110b = 1000 $\mu$ s 0111b = 1200 $\mu$ s 1000b = 1400 $\mu$ s 1001b = 2000 $\mu$ s 1010b = 2400 $\mu$ s 1011b = 3200 $\mu$ s 1100b = 4000 $\mu$ s 1101b = 5200 $\mu$ s 1110b = 6400 $\mu$ s 1111b = 8000 $\mu$ s This bit-field powers-up un-initialized.

**7.6.3.60 P1\_THR\_1 Register (Address = 60h) [reset = X]**

P1\_THR\_1 is shown in [Figure 104](#) and described in [Table 68](#).

Return to [Summary Table](#).

Preset1 threshold map segment configuration register 1

**Figure 104. P1\_THR\_1 Register**

7	6	5	4	3	2	1	0
TH_P1_T3				TH_P1_T4			
R/W-X				R/W-X			

**Table 68. P1\_THR\_1 Register Field Descriptions**

Bit	Field	Type	Reset	Description
7:4	TH_P1_T3	R/W	X	Preset1 Threshold T3 delta time: 0000b = 100 $\mu$ s 0001b = 200 $\mu$ s 0010b = 300 $\mu$ s 0011b = 400 $\mu$ s 0100b = 600 $\mu$ s 0101b = 800 $\mu$ s 0110b = 1000 $\mu$ s 0111b = 1200 $\mu$ s 1000b = 1400 $\mu$ s 1001b = 2000 $\mu$ s 1010b = 2400 $\mu$ s 1011b = 3200 $\mu$ s 1100b = 4000 $\mu$ s 1101b = 5200 $\mu$ s 1110b = 6400 $\mu$ s 1111b = 8000 $\mu$ s This bit-field powers-up un-initialized.

**Table 68. P1\_THR\_1 Register Field Descriptions (continued)**

Bit	Field	Type	Reset	Description
3:0	TH_P1_T4	R/W	X	Preset1 Threshold T4 delta time: 0000b = 100 $\mu$ s 0001b = 200 $\mu$ s 0010b = 300 $\mu$ s 0011b = 400 $\mu$ s 0100b = 600 $\mu$ s 0101b = 800 $\mu$ s 0110b = 1000 $\mu$ s 0111b = 1200 $\mu$ s 1000b = 1400 $\mu$ s 1001b = 2000 $\mu$ s 1010b = 2400 $\mu$ s 1011b = 3200 $\mu$ s 1100b = 4000 $\mu$ s 1101b = 5200 $\mu$ s 1110b = 6400 $\mu$ s 1111b = 8000 $\mu$ s This bit-field powers-up un-initialized.

**7.6.3.61 P1\_THR\_2 Register (Address = 61h) [reset = X]**

 P1\_THR\_2 is shown in [Figure 105](#) and described in [Table 69](#).

 Return to [Summary Table](#).

Preset1 threshold map segment configuration register 2

**Figure 105. P1\_THR\_2 Register**

7	6	5	4	3	2	1	0
TH_P1_T5				TH_P1_T6			
R/W-X				R/W-X			

**Table 69. P1\_THR\_2 Register Field Descriptions**

Bit	Field	Type	Reset	Description
7:4	TH_P1_T5	R/W	X	Preset1 Threshold T5 delta time: 0000b = 100 $\mu$ s 0001b = 200 $\mu$ s 0010b = 300 $\mu$ s 0011b = 400 $\mu$ s 0100b = 600 $\mu$ s 0101b = 800 $\mu$ s 0110b = 1000 $\mu$ s 0111b = 1200 $\mu$ s 1000b = 1400 $\mu$ s 1001b = 2000 $\mu$ s 1010b = 2400 $\mu$ s 1011b = 3200 $\mu$ s 1100b = 4000 $\mu$ s 1101b = 5200 $\mu$ s 1110b = 6400 $\mu$ s 1111b = 8000 $\mu$ s This bit-field powers-up un-initialized.

**Table 69. P1\_THR\_2 Register Field Descriptions (continued)**

Bit	Field	Type	Reset	Description
3:0	TH_P1_T6	R/W	X	Preset1 Threshold T6 delta time: 0000b = 100 $\mu$ s 0001b = 200 $\mu$ s 0010b = 300 $\mu$ s 0011b = 400 $\mu$ s 0100b = 600 $\mu$ s 0101b = 800 $\mu$ s 0110b = 1000 $\mu$ s 0111b = 1200 $\mu$ s 1000b = 1400 $\mu$ s 1001b = 2000 $\mu$ s 1010b = 2400 $\mu$ s 1011b = 3200 $\mu$ s 1100b = 4000 $\mu$ s 1101b = 5200 $\mu$ s 1110b = 6400 $\mu$ s 1111b = 8000 $\mu$ s This bit-field powers-up un-initialized.

**7.6.3.62 P1\_THR\_3 Register (Address = 62h) [reset = X]**

P1\_THR\_3 is shown in [Figure 106](#) and described in [Table 70](#).

Return to [Summary Table](#).

Preset1 threshold map segment configuration register 3

**Figure 106. P1\_THR\_3 Register**

7	6	5	4	3	2	1	0
TH_P1_T7				TH_P1_T8			
R/W-X				R/W-X			

**Table 70. P1\_THR\_3 Register Field Descriptions**

Bit	Field	Type	Reset	Description
7:4	TH_P1_T7	R/W	X	Preset1 Threshold T7 delta time: 0000b = 100 $\mu$ s 0001b = 200 $\mu$ s 0010b = 300 $\mu$ s 0011b = 400 $\mu$ s 0100b = 600 $\mu$ s 0101b = 800 $\mu$ s 0110b = 1000 $\mu$ s 0111b = 1200 $\mu$ s 1000b = 1400 $\mu$ s 1001b = 2000 $\mu$ s 1010b = 2400 $\mu$ s 1011b = 3200 $\mu$ s 1100b = 4000 $\mu$ s 1101b = 5200 $\mu$ s 1110b = 6400 $\mu$ s 1111b = 8000 $\mu$ s This bit-field powers-up un-initialized.

**Table 70. P1\_THR\_3 Register Field Descriptions (continued)**

Bit	Field	Type	Reset	Description
3:0	TH_P1_T8	R/W	X	Preset1 Threshold T8 delta time: 0000b = 100 $\mu$ s 0001b = 200 $\mu$ s 0010b = 300 $\mu$ s 0011b = 400 $\mu$ s 0100b = 600 $\mu$ s 0101b = 800 $\mu$ s 0110b = 1000 $\mu$ s 0111b = 1200 $\mu$ s 1000b = 1400 $\mu$ s 1001b = 2000 $\mu$ s 1010b = 2400 $\mu$ s 1011b = 3200 $\mu$ s 1100b = 4000 $\mu$ s 1101b = 5200 $\mu$ s 1110b = 6400 $\mu$ s 1111b = 8000 $\mu$ s This bit-field powers-up un-initialized.

**7.6.3.63 P1\_THR\_4 Register (Address = 63h) [reset = X]**

 P1\_THR\_4 is shown in [Figure 107](#) and described in [Table 71](#).

 Return to [Summary Table](#).

Preset1 threshold map segment configuration register 4

**Figure 107. P1\_THR\_4 Register**

7	6	5	4	3	2	1	0
TH_P1_T9				TH_P1_T10			
R/W-X				R/W-X			

**Table 71. P1\_THR\_4 Register Field Descriptions**

Bit	Field	Type	Reset	Description
7:4	TH_P1_T9	R/W	X	Preset1 Threshold T9 delta time: 0000b = 100 $\mu$ s 0001b = 200 $\mu$ s 0010b = 300 $\mu$ s 0011b = 400 $\mu$ s 0100b = 600 $\mu$ s 0101b = 800 $\mu$ s 0110b = 1000 $\mu$ s 0111b = 1200 $\mu$ s 1000b = 1400 $\mu$ s 1001b = 2000 $\mu$ s 1010b = 2400 $\mu$ s 1011b = 3200 $\mu$ s 1100b = 4000 $\mu$ s 1101b = 5200 $\mu$ s 1110b = 6400 $\mu$ s 1111b = 8000 $\mu$ s This bit-field powers-up un-initialized.



**Table 71. P1\_THR\_4 Register Field Descriptions (continued)**

Bit	Field	Type	Reset	Description
3:0	TH_P1_T10	R/W	X	Preset1 Threshold T10 delta time: 0000b = 100 $\mu$ s 0001b = 200 $\mu$ s 0010b = 300 $\mu$ s 0011b = 400 $\mu$ s 0100b = 600 $\mu$ s 0101b = 800 $\mu$ s 0110b = 1000 $\mu$ s 0111b = 1200 $\mu$ s 1000b = 1400 $\mu$ s 1001b = 2000 $\mu$ s 1010b = 2400 $\mu$ s 1011b = 3200 $\mu$ s 1100b = 4000 $\mu$ s 1101b = 5200 $\mu$ s 1110b = 6400 $\mu$ s 1111b = 8000 $\mu$ s This bit-field powers-up un-initialized.

**7.6.3.64 P1\_THR\_5 Register (Address = 64h) [reset = X]**

P1\_THR\_5 is shown in [Figure 108](#) and described in [Table 72](#).

Return to [Summary Table](#).

Preset1 threshold map segment configuration register 5

**Figure 108. P1\_THR\_5 Register**

7	6	5	4	3	2	1	0
TH_P1_T11				TH_P1_T12			
R/W-X				R/W-X			

**Table 72. P1\_THR\_5 Register Field Descriptions**

Bit	Field	Type	Reset	Description
7:4	TH_P1_T11	R/W	X	Preset1 Threshold T11 delta time: 0000b = 100 $\mu$ s 0001b = 200 $\mu$ s 0010b = 300 $\mu$ s 0011b = 400 $\mu$ s 0100b = 600 $\mu$ s 0101b = 800 $\mu$ s 0110b = 1000 $\mu$ s 0111b = 1200 $\mu$ s 1000b = 1400 $\mu$ s 1001b = 2000 $\mu$ s 1010b = 2400 $\mu$ s 1011b = 3200 $\mu$ s 1100b = 4000 $\mu$ s 1101b = 5200 $\mu$ s 1110b = 6400 $\mu$ s 1111b = 8000 $\mu$ s This bit-field powers-up un-initialized.

**Table 72. P1\_THR\_5 Register Field Descriptions (continued)**

Bit	Field	Type	Reset	Description
3:0	TH_P1_T12	R/W	X	Preset1 Threshold T12 delta time: 0000b = 100 $\mu$ s 0001b = 200 $\mu$ s 0010b = 300 $\mu$ s 0011b = 400 $\mu$ s 0100b = 600 $\mu$ s 0101b = 800 $\mu$ s 0110b = 1000 $\mu$ s 0111b = 1200 $\mu$ s 1000b = 1400 $\mu$ s 1001b = 2000 $\mu$ s 1010b = 2400 $\mu$ s 1011b = 3200 $\mu$ s 1100b = 4000 $\mu$ s 1101b = 5200 $\mu$ s 1110b = 6400 $\mu$ s 1111b = 8000 $\mu$ s This bit-field powers-up un-initialized.

**7.6.3.65 P1\_THR\_6 Register (Address = 65h) [reset = X]**

 P1\_THR\_6 is shown in [Figure 109](#) and described in [Table 73](#).

 Return to [Summary Table](#).

Preset1 threshold map segment configuration register 6

**Figure 109. P1\_THR\_6 Register**

7	6	5	4	3	2	1	0
TH_P1_L1				TH_P1_L2			
R/W-X				R/W-X			

**Table 73. P1\_THR\_6 Register Field Descriptions**

Bit	Field	Type	Reset	Description
7:3	TH_P1_L1	R/W	X	Preset1 Threshold L1 level This bit-field powers-up un-initialized.
2:0	TH_P1_L2	R/W	X	Preset1 Threshold L2 level bits (Bit4 to Bit2) This bit-field powers-up un-initialized.

**7.6.3.66 P1\_THR\_7 Register (Address = 66h) [reset = X]**

 P1\_THR\_7 is shown in [Figure 110](#) and described in [Table 74](#).

 Return to [Summary Table](#).

Preset1 threshold map segment configuration register 7

**Figure 110. P1\_THR\_7 Register**

7	6	5	4	3	2	1	0
TH_P1_L2		TH_P1_L3				TH_P1_L4	
R/W-X		R/W-X				R/W-X	

**Table 74. P1\_THR\_7 Register Field Descriptions**

Bit	Field	Type	Reset	Description
7:6	TH_P1_L2	R/W	X	Preset1 Threshold L2 level (Bit1 to Bit0) This bit-field powers-up un-initialized.

**Table 74. P1\_THR\_7 Register Field Descriptions (continued)**

Bit	Field	Type	Reset	Description
5:1	TH_P1_L3	R/W	X	Preset1 Threshold L3 level This bit-field powers-up un-initialized.
0	TH_P1_L4	R/W	X	Preset1 Threshold L4 level (Bit4) This bit-field powers-up un-initialized.

**7.6.3.67 P1\_THR\_8 Register (Address = 67h) [reset = X]**

P1\_THR\_8 is shown in [Figure 111](#) and described in [Table 75](#).

Return to [Summary Table](#).

Preset1 threshold map segment configuration register 8

**Figure 111. P1\_THR\_8 Register**

7	6	5	4	3	2	1	0
TH_P1_L4				TH_P1_L5			
R/W-X				R/W-X			

**Table 75. P1\_THR\_8 Register Field Descriptions**

Bit	Field	Type	Reset	Description
7:4	TH_P1_L4	R/W	X	Preset1 Threshold L4 level (Bits3 to Bit0) This bit-field powers-up un-initialized.
3:0	TH_P1_L5	R/W	X	Preset1 Threshold L5 level (Bit4 to Bit1) This bit-field powers-up un-initialized.

**7.6.3.68 P1\_THR\_9 Register (Address = 68h) [reset = X]**

P1\_THR\_9 is shown in [Figure 112](#) and described in [Table 76](#).

Return to [Summary Table](#).

Preset1 threshold map segment configuration register 9

**Figure 112. P1\_THR\_9 Register**

7	6	5	4	3	2	1	0
TH_P1_L5	TH_P1_L6				TH_P1_L7		
R/W-X	R/W-X				R/W-X		

**Table 76. P1\_THR\_9 Register Field Descriptions**

Bit	Field	Type	Reset	Description
7	TH_P1_L5	R/W	X	Preset1 Threshold L5 level (Bit0) This bit-field powers-up un-initialized.
6:2	TH_P1_L6	R/W	X	Preset1 Threshold L6 level This bit-field powers-up un-initialized.
1:0	TH_P1_L7	R/W	X	Preset1 Threshold L7 level (Bits4 to Bit3) This bit-field powers-up un-initialized.

**7.6.3.69 P1\_THR\_10 Register (Address = 69h) [reset = X]**

P1\_THR\_10 is shown in [Figure 113](#) and described in [Table 77](#).

Return to [Summary Table](#).

Preset1 threshold map segment configuration register 10

**Figure 113. P1\_THR\_10 Register**

7	6	5	4	3	2	1	0
TH_P1_L7				TH_P1_L8			
R/W-X				R/W-X			

**Table 77. P1\_THR\_10 Register Field Descriptions**

Bit	Field	Type	Reset	Description
7:5	TH_P1_L7	R/W	X	Preset1 Threshold L7 Level (Bit2 to Bit0) This bit-field powers-up un-initialized.
4:0	TH_P1_L8	R/W	X	Preset1 Threshold L8 level This bit-field powers-up un-initialized.

**7.6.3.70 P1\_THR\_11 Register (Address = 6Ah) [reset = X]**

 P1\_THR\_11 is shown in [Figure 114](#) and described in [Table 78](#).

 Return to [Summary Table](#).

Preset1 threshold map segment configuration register 11

**Figure 114. P1\_THR\_11 Register**

7	6	5	4	3	2	1	0
TH_P1_L9							
R/W-X							

**Table 78. P1\_THR\_11 Register Field Descriptions**

Bit	Field	Type	Reset	Description
7:0	TH_P1_L9	R/W	X	Threshold L9 level This bit-field powers-up un-initialized.

**7.6.3.71 P1\_THR\_12 Register (Address = 6Bh) [reset = X]**

 P1\_THR\_12 is shown in [Figure 115](#) and described in [Table 79](#).

 Return to [Summary Table](#).

Preset1 threshold map segment configuration register 12

**Figure 115. P1\_THR\_12 Register**

7	6	5	4	3	2	1	0
TH_P1_L10							
R/W-X							

**Table 79. P1\_THR\_12 Register Field Descriptions**

Bit	Field	Type	Reset	Description
7:0	TH_P1_L10	R/W	X	Preset1 Threshold L10 Level This bit-field powers-up un-initialized.

**7.6.3.72 P1\_THR\_13 Register (Address = 6Ch) [reset = X]**

 P1\_THR\_13 is shown in [Figure 116](#) and described in [Table 80](#).

 Return to [Summary Table](#).

Preset1 threshold map segment configuration register 13

**Figure 116. P1\_THR\_13 Register**

7	6	5	4	3	2	1	0
TH_P1_L11							
R/W-X							

**Table 80. P1\_THR\_13 Register Field Descriptions**

Bit	Field	Type	Reset	Description
7:0	TH_P1_L11	R/W	X	Preset1 Threshold L11 Level This bit-field powers-up un-initialized.

**7.6.3.73 P1\_THR\_14 Register (Address = 6Dh) [reset = X]**

P1\_THR\_14 is shown in [Figure 117](#) and described in [Table 81](#).

Return to [Summary Table](#).

Preset1 threshold map segment configuration register 14

**Figure 117. P1\_THR\_14 Register**

7	6	5	4	3	2	1	0
TH_P1_L12							
R/W-X							

**Table 81. P1\_THR\_14 Register Field Descriptions**

Bit	Field	Type	Reset	Description
7:0	TH_P1_L12	R/W	X	Preset1 Threshold L12 Level. This bit-field powers-up un-initialized.

**7.6.3.74 P1\_THR\_15 Register (Address = 6Eh) [reset = X]**

P1\_THR\_15 is shown in [Figure 118](#) and described in [Table 82](#).

Return to [Summary Table](#).

Preset1 threshold map segment configuration register 15

**Figure 118. P1\_THR\_15 Register**

7	6	5	4	3	2	1	0
RESERVED				TH_P1_OFF			
R-X				R/W-X			

**Table 82. P1\_THR\_15 Register Field Descriptions**

Bit	Field	Type	Reset	Description
7:4	RESERVED	R	X	Reserved
3:0	TH_P1_OFF	R/W	X	Preset1 Threshold level Offset with values from 7 to -8 using signed magnitude representation with MSB as the sign bit This bit-field powers-up un-initialized.

**7.6.3.75 P2\_THR\_0 Register (Address = 6Fh) [reset = X]**

P2\_THR\_0 is shown in [Figure 119](#) and described in [Table 83](#).

Return to [Summary Table](#).

Preset2 threshold map segment configuration register 0

**Figure 119. P2\_THR\_0 Register**

7	6	5	4	3	2	1	0
TH_P2_T1				TH_P2_T2			
R/W-X				R/W-X			

**Table 83. P2\_THR\_0 Register Field Descriptions**

Bit	Field	Type	Reset	Description
7:4	TH_P2_T1	R/W	X	Preset2 Threshold T1 absolute time: 0000b = 100 $\mu$ s 0001b = 200 $\mu$ s 0010b = 300 $\mu$ s 0011b = 400 $\mu$ s 0100b = 600 $\mu$ s 0101b = 800 $\mu$ s 0110b = 1000 $\mu$ s 0111b = 1200 $\mu$ s 1000b = 1400 $\mu$ s 1001b = 2000 $\mu$ s 1010b = 2400 $\mu$ s 1011b = 3200 $\mu$ s 1100b = 4000 $\mu$ s 1101b = 5200 $\mu$ s 1110b = 6400 $\mu$ s 1111b = 8000 $\mu$ s This bit-field powers-up un-initialized.
3:0	TH_P2_T2	R/W	X	Preset2 Threshold T2 delta time: 0000b = 100 $\mu$ s 0001b = 200 $\mu$ s 0010b = 300 $\mu$ s 0011b = 400 $\mu$ s 0100b = 600 $\mu$ s 0101b = 800 $\mu$ s 0110b = 1000 $\mu$ s 0111b = 1200 $\mu$ s 1000b = 1400 $\mu$ s 1001b = 2000 $\mu$ s 1010b = 2400 $\mu$ s 1011b = 3200 $\mu$ s 1100b = 4000 $\mu$ s 1101b = 5200 $\mu$ s 1110b = 6400 $\mu$ s 1111b = 8000 $\mu$ s This bit-field powers-up un-initialized.

**7.6.3.76 P2\_THR\_1 Register (Address = 70h) [reset = X]**

 P2\_THR\_1 is shown in [Figure 120](#) and described in [Table 84](#).

 Return to [Summary Table](#).

Preset2 threshold map segment configuration register 1

**Figure 120. P2\_THR\_1 Register**

7	6	5	4	3	2	1	0
TH_P2_T3				TH_P2_T4			
R/W-X				R/W-X			

**Table 84. P2\_THR\_1 Register Field Descriptions**

Bit	Field	Type	Reset	Description
7:4	TH_P2_T3	R/W	X	Preset2 Threshold T3 delta time: 0000b = 100 $\mu$ s 0001b = 200 $\mu$ s 0010b = 300 $\mu$ s 0011b = 400 $\mu$ s 0100b = 600 $\mu$ s 0101b = 800 $\mu$ s 0110b = 1000 $\mu$ s 0111b = 1200 $\mu$ s 1000b = 1400 $\mu$ s 1001b = 2000 $\mu$ s 1010b = 2400 $\mu$ s 1011b = 3200 $\mu$ s 1100b = 4000 $\mu$ s 1101b = 5200 $\mu$ s 1110b = 6400 $\mu$ s 1111b = 8000 $\mu$ s This bit-field powers-up un-initialized.
3:0	TH_P2_T4	R/W	X	Preset2 Threshold T4 delta time: 0000b = 100 $\mu$ s 0001b = 200 $\mu$ s 0010b = 300 $\mu$ s 0011b = 400 $\mu$ s 0100b = 600 $\mu$ s 0101b = 800 $\mu$ s 0110b = 1000 $\mu$ s 0111b = 1200 $\mu$ s 1000b = 1400 $\mu$ s 1001b = 2000 $\mu$ s 1010b = 2400 $\mu$ s 1011b = 3200 $\mu$ s 1100b = 4000 $\mu$ s 1101b = 5200 $\mu$ s 1110b = 6400 $\mu$ s 1111b = 8000 $\mu$ s This bit-field powers-up un-initialized.

**7.6.3.77 P2\_THR\_2 Register (Address = 71h) [reset = X]**

P2\_THR\_2 is shown in [Figure 121](#) and described in [Table 85](#).

Return to [Summary Table](#).

Preset2 threshold map segment configuration register 2

**Figure 121. P2\_THR\_2 Register**

7	6	5	4	3	2	1	0
TH_P2_T5				TH_P2_T6			
R/W-X				R/W-X			

**Table 85. P2\_THR\_2 Register Field Descriptions**

Bit	Field	Type	Reset	Description
7:4	TH_P2_T5	R/W	X	Preset2 Threshold T5 delta time: 0000b = 100 $\mu$ s 0001b = 200 $\mu$ s 0010b = 300 $\mu$ s 0011b = 400 $\mu$ s 0100b = 600 $\mu$ s 0101b = 800 $\mu$ s 0110b = 1000 $\mu$ s 0111b = 1200 $\mu$ s 1000b = 1400 $\mu$ s 1001b = 2000 $\mu$ s 1010b = 2400 $\mu$ s 1011b = 3200 $\mu$ s 1100b = 4000 $\mu$ s 1101b = 5200 $\mu$ s 1110b = 6400 $\mu$ s 1111b = 8000 $\mu$ s This bit-field powers-up un-initialized.
3:0	TH_P2_T6	R/W	X	Preset2 Threshold T6 delta time: 0000b = 100 $\mu$ s 0001b = 200 $\mu$ s 0010b = 300 $\mu$ s 0011b = 400 $\mu$ s 0100b = 600 $\mu$ s 0101b = 800 $\mu$ s 0110b = 1000 $\mu$ s 0111b = 1200 $\mu$ s 1000b = 1400 $\mu$ s 1001b = 2000 $\mu$ s 1010b = 2400 $\mu$ s 1011b = 3200 $\mu$ s 1100b = 4000 $\mu$ s 1101b = 5200 $\mu$ s 1110b = 6400 $\mu$ s 1111b = 8000 $\mu$ s This bit-field powers-up un-initialized.

**7.6.3.78 P2\_THR\_3 Register (Address = 72h) [reset = X]**

 P2\_THR\_3 is shown in [Figure 122](#) and described in [Table 86](#).

 Return to [Summary Table](#).

Preset2 threshold map segment configuration register 3

**Figure 122. P2\_THR\_3 Register**

7	6	5	4	3	2	1	0
TH_P2_T7				TH_P2_T8			
R/W-X				R/W-X			



**Table 86. P2\_THR\_3 Register Field Descriptions**

Bit	Field	Type	Reset	Description
7:4	TH_P2_T7	R/W	X	Preset2 Threshold T7 delta time: 0000b = 100 $\mu$ s 0001b = 200 $\mu$ s 0010b = 300 $\mu$ s 0011b = 400 $\mu$ s 0100b = 600 $\mu$ s 0101b = 800 $\mu$ s 0110b = 1000 $\mu$ s 0111b = 1200 $\mu$ s 1000b = 1400 $\mu$ s 1001b = 2000 $\mu$ s 1010b = 2400 $\mu$ s 1011b = 3200 $\mu$ s 1100b = 4000 $\mu$ s 1101b = 5200 $\mu$ s 1110b = 6400 $\mu$ s 1111b = 8000 $\mu$ s This bit-field powers-up un-initialized.
3:0	TH_P2_T8	R/W	X	Preset2 Threshold T8 delta time: 0000b = 100 $\mu$ s 0001b = 200 $\mu$ s 0010b = 300 $\mu$ s 0011b = 400 $\mu$ s 0100b = 600 $\mu$ s 0101b = 800 $\mu$ s 0110b = 1000 $\mu$ s 0111b = 1200 $\mu$ s 1000b = 1400 $\mu$ s 1001b = 2000 $\mu$ s 1010b = 2400 $\mu$ s 1011b = 3200 $\mu$ s 1100b = 4000 $\mu$ s 1101b = 5200 $\mu$ s 1110b = 6400 $\mu$ s 1111b = 8000 $\mu$ s This bit-field powers-up un-initialized.

**7.6.3.79 P2\_THR\_4 Register (Address = 73h) [reset = X]**

P2\_THR\_4 is shown in [Figure 123](#) and described in [Table 87](#).

Return to [Summary Table](#).

Preset2 threshold map segment configuration register 4

**Figure 123. P2\_THR\_4 Register**

7	6	5	4	3	2	1	0
TH_P2_T9				TH_P2_T10			
R/W-X				R/W-X			

**Table 87. P2\_THR\_4 Register Field Descriptions**

Bit	Field	Type	Reset	Description
7:4	TH_P2_T9	R/W	X	Preset2 Threshold T9 delta time: 0000b = 100 $\mu$ s 0001b = 200 $\mu$ s 0010b = 300 $\mu$ s 0011b = 400 $\mu$ s 0100b = 600 $\mu$ s 0101b = 800 $\mu$ s 0110b = 1000 $\mu$ s 0111b = 1200 $\mu$ s 1000b = 1400 $\mu$ s 1001b = 2000 $\mu$ s 1010b = 2400 $\mu$ s 1011b = 3200 $\mu$ s 1100b = 4000 $\mu$ s 1101b = 5200 $\mu$ s 1110b = 6400 $\mu$ s 1111b = 8000 $\mu$ s This bit-field powers-up un-initialized.
3:0	TH_P2_T10	R/W	X	Preset2 Threshold T10 delta time: 0000b = 100 $\mu$ s 0001b = 200 $\mu$ s 0010b = 300 $\mu$ s 0011b = 400 $\mu$ s 0100b = 600 $\mu$ s 0101b = 800 $\mu$ s 0110b = 1000 $\mu$ s 0111b = 1200 $\mu$ s 1000b = 1400 $\mu$ s 1001b = 2000 $\mu$ s 1010b = 2400 $\mu$ s 1011b = 3200 $\mu$ s 1100b = 4000 $\mu$ s 1101b = 5200 $\mu$ s 1110b = 6400 $\mu$ s 1111b = 8000 $\mu$ s This bit-field powers-up un-initialized.

**7.6.3.80 P2\_THR\_5 Register (Address = 74h) [reset = X]**

 P2\_THR\_5 is shown in [Figure 124](#) and described in [Table 88](#).

 Return to [Summary Table](#).

Preset2 threshold map segment configuration register 5

**Figure 124. P2\_THR\_5 Register**

7	6	5	4	3	2	1	0
TH_P2_T11				TH_P2_T12			
R/W-X				R/W-X			

**Table 88. P2\_THR\_5 Register Field Descriptions**

Bit	Field	Type	Reset	Description
7:4	TH_P2_T11	R/W	X	Preset2 Threshold T11 delta time: 0000b = 100 $\mu$ s 0001b = 200 $\mu$ s 0010b = 300 $\mu$ s 0011b = 400 $\mu$ s 0100b = 600 $\mu$ s 0101b = 800 $\mu$ s 0110b = 1000 $\mu$ s 0111b = 1200 $\mu$ s 1000b = 1400 $\mu$ s 1001b = 2000 $\mu$ s 1010b = 2400 $\mu$ s 1011b = 3200 $\mu$ s 1100b = 4000 $\mu$ s 1101b = 5200 $\mu$ s 1110b = 6400 $\mu$ s 1111b = 8000 $\mu$ s This bit-field powers-up un-initialized.
3:0	TH_P2_T12	R/W	X	Preset2 Threshold T12 delta time: 0000b = 100 $\mu$ s 0001b = 200 $\mu$ s 0010b = 300 $\mu$ s 0011b = 400 $\mu$ s 0100b = 600 $\mu$ s 0101b = 800 $\mu$ s 0110b = 1000 $\mu$ s 0111b = 1200 $\mu$ s 1000b = 1400 $\mu$ s 1001b = 2000 $\mu$ s 1010b = 2400 $\mu$ s 1011b = 3200 $\mu$ s 1100b = 4000 $\mu$ s 1101b = 5200 $\mu$ s 1110b = 6400 $\mu$ s 1111b = 8000 $\mu$ s This bit-field powers-up un-initialized.

**7.6.3.81 P2\_THR\_6 Register (Address = 75h) [reset = X]**

P2\_THR\_6 is shown in [Figure 125](#) and described in [Table 89](#).

Return to [Summary Table](#).

Preset2 threshold map segment configuration register 6

**Figure 125. P2\_THR\_6 Register**

7	6	5	4	3	2	1	0
TH_P2_L1				TH_P2_L2			
R/W-X				R/W-X			

**Table 89. P2\_THR\_6 Register Field Descriptions**

Bit	Field	Type	Reset	Description
7:3	TH_P2_L1	R/W	X	Preset2 Threshold L1 level This bit-field powers-up un-initialized.
2:0	TH_P2_L2	R/W	X	Preset2 Threshold L2 level (Bit4 to Bit2) This bit-field powers-up un-initialized.

**7.6.3.82 P2\_THR\_7 Register (Address = 76h) [reset = X]**

 P2\_THR\_7 is shown in [Figure 126](#) and described in [Table 90](#).

 Return to [Summary Table](#).

Preset2 threshold map segment configuration register 7

**Figure 126. P2\_THR\_7 Register**

7	6	5	4	3	2	1	0
TH_P2_L2		TH_P2_L3				TH_P2_L4	
R/W-X		R/W-X				R/W-X	

**Table 90. P2\_THR\_7 Register Field Descriptions**

Bit	Field	Type	Reset	Description
7:6	TH_P2_L2	R/W	X	Preset2 Threshold L2 level (Bit1 to Bit0) This bit-field powers-up un-initialized.
5:1	TH_P2_L3	R/W	X	Preset2 Threshold L3 level This bit-field powers-up un-initialized.
0	TH_P2_L4	R/W	X	Preset2 Threshold L4 level (Bit4) This bit-field powers-up un-initialized.

**7.6.3.83 P2\_THR\_8 Register (Address = 77h) [reset = X]**

 P2\_THR\_8 is shown in [Figure 127](#) and described in [Table 91](#).

 Return to [Summary Table](#).

Preset2 threshold map segment configuration register 8

**Figure 127. P2\_THR\_8 Register**

7	6	5	4	3	2	1	0
TH_P2_L4				TH_P2_L5			
R/W-X				R/W-X			

**Table 91. P2\_THR\_8 Register Field Descriptions**

Bit	Field	Type	Reset	Description
7:4	TH_P2_L4	R/W	X	Preset2 Threshold L4 level (Bit3 to Bit0) This bit-field powers-up un-initialized.
3:0	TH_P2_L5	R/W	X	Preset2 Threshold L5 level (Bit4 to Bit1) This bit-field powers-up un-initialized.

**7.6.3.84 P2\_THR\_9 Register (Address = 78h) [reset = X]**

 P2\_THR\_9 is shown in [Figure 128](#) and described in [Table 92](#).

 Return to [Summary Table](#).

Preset2 threshold map segment configuration register 9

**Figure 128. P2\_THR\_9 Register**

7	6	5	4	3	2	1	0
TH_P2_L5		TH_P2_L6				TH_P2_L7	
R/W-X		R/W-X				R/W-X	

**Table 92. P2\_THR\_9 Register Field Descriptions**

Bit	Field	Type	Reset	Description
7	TH_P2_L5	R/W	X	Preset2 Threshold L5 level (Bit0) This bit-field powers-up un-initialized.
6:2	TH_P2_L6	R/W	X	Preset2 Threshold L6 level This bit-field powers-up un-initialized.
1:0	TH_P2_L7	R/W	X	Preset2 Threshold L7 level (Bit4 to Bit3) This bit-field powers-up un-initialized.

**7.6.3.85 P2\_THR\_10 Register (Address = 79h) [reset = X]**

P2\_THR\_10 is shown in [Figure 129](#) and described in [Table 93](#).

Return to [Summary Table](#).

Preset2 threshold map segment configuration register 10

**Figure 129. P2\_THR\_10 Register**

7	6	5	4	3	2	1	0
TH_P2_L7			TH_P2_L8				
R/W-X			R/W-X				

**Table 93. P2\_THR\_10 Register Field Descriptions**

Bit	Field	Type	Reset	Description
7:5	TH_P2_L7	R/W	X	Preset2 Threshold L7 level (Bit2 to Bit0) This bit-field powers-up un-initialized.
4:0	TH_P2_L8	R/W	X	Preset2 Threshold L8 level This bit-field powers-up un-initialized.

**7.6.3.86 P2\_THR\_11 Register (Address = 7Ah) [reset = X]**

P2\_THR\_11 is shown in [Figure 130](#) and described in [Table 94](#).

Return to [Summary Table](#).

Preset2 threshold map segment configuration register 11

**Figure 130. P2\_THR\_11 Register**

7	6	5	4	3	2	1	0
TH_P2_L9							
R/W-X							

**Table 94. P2\_THR\_11 Register Field Descriptions**

Bit	Field	Type	Reset	Description
7:0	TH_P2_L9	R/W	X	Preset2 Threshold L9 level This bit-field powers-up un-initialized.

**7.6.3.87 P2\_THR\_12 Register (Address = 7Bh) [reset = X]**

P2\_THR\_12 is shown in [Figure 131](#) and described in [Table 95](#).

Return to [Summary Table](#).

Preset2 threshold map segment configuration register 12

**Figure 131. P2\_THR\_12 Register**

7	6	5	4	3	2	1	0
TH_P2_L10							
R/W-X							

**Table 95. P2\_THR\_12 Register Field Descriptions**

Bit	Field	Type	Reset	Description
7:0	TH_P2_L10	R/W	X	Preset2 Threshold L10 Level This bit-field powers-up un-initialized.

**7.6.3.88 P2\_THR\_13 Register (Address = 7Ch) [reset = X]**

 P2\_THR\_13 is shown in [Figure 132](#) and described in [Table 96](#).

 Return to [Summary Table](#).

Preset2 threshold map segment configuration register 13

**Figure 132. P2\_THR\_13 Register**

7	6	5	4	3	2	1	0
TH_P2_L11							
R/W-X							

**Table 96. P2\_THR\_13 Register Field Descriptions**

Bit	Field	Type	Reset	Description
7:0	TH_P2_L11	R/W	X	Preset2 Threshold L11 Level This bit-field powers-up un-initialized.

**7.6.3.89 P2\_THR\_14 Register (Address = 7Dh) [reset = X]**

 P2\_THR\_14 is shown in [Figure 133](#) and described in [Table 97](#).

 Return to [Summary Table](#).

Preset2 threshold map segment configuration register 14

**Figure 133. P2\_THR\_14 Register**

7	6	5	4	3	2	1	0
TH_P2_L12							
R/W-X							

**Table 97. P2\_THR\_14 Register Field Descriptions**

Bit	Field	Type	Reset	Description
7:0	TH_P2_L12	R/W	X	Preset2 Threshold L12 Level This bit-field powers-up un-initialized.

**7.6.3.90 P2\_THR\_15 Register (Address = 7Eh) [reset = X]**

 P2\_THR\_15 is shown in [Figure 134](#) and described in [Table 98](#).

 Return to [Summary Table](#).

Preset2 threshold map segment configuration register 15

**Figure 134. P2\_THR\_15 Register**

7	6	5	4	3	2	1	0
RESERVED				TH_P2_OFF			
R-X				R/W-X			

**Table 98. P2\_THR\_15 Register Field Descriptions**

Bit	Field	Type	Reset	Description
7:4	RESERVED	R	X	Reserved
3:0	TH_P2_OFF	R/W	X	Preset2 Threshold level Offset with values from 7 to -8 using signed magnitude representation with MSB as the sign bit This bit-field powers-up un-initialized.

### 7.6.3.91 THR\_CRC Register (Address = 7Fh) [reset = X]

THR\_CRC is shown in [Figure 135](#) and described in [Table 99](#).

Return to [Summary Table](#).

Threshold map configuration registers data CRC register

**Figure 135. THR\_CRC Register**

7	6	5	4	3	2	1	0
THR_CRC							
R/W-X							

**Table 99. THR\_CRC Register Field Descriptions**

Bit	Field	Type	Reset	Description
7:0	THR_CRC	R/W	X	Threshold map configuration registers data CRC value: This read-only register is updated whenever a threshold map configuration register gets updated This bit-field powers-up un-initialized.

## 8 Application and Implementation

---

### 注

Information in the following applications sections is not part of the TI component specification, and TI does not warrant its accuracy or completeness. TI's customers are responsible for determining suitability of components for their purposes. Customers should validate and test their design implementation to confirm system functionality.

---

### 8.1 Application Information

The PGA460 device must be paired with an external transducer. The PGA460 device drives the transducer, and then filters and processes the returned echo signal sensed by the transducer. The transducer should be chosen based on the resonant frequency, input voltage requirements, sensitivity, beam pattern, and decay time. The PGA460 device meets most transducer requirements by adjusting the driving frequency, driving current limit, band-pass filtering coefficients, and low-pass filtering coefficients. The external transformer or p-channel MOSFET should be chosen to meet the input voltage requirements of the transducer and have a saturation current rated equal to or greater than the configured driving current limit of the PGA460 device. The interface options include USART, TCI, and one-wire UART. After the burst-and-listen cycle is complete, the PGA460 device can be called to return the distance, amplitude, and width of the echo through a communication interface.

#### 8.1.1 Transducer Types

The driver mode is dependant on the transducer type. Two types of transducers are available for open-air ultrasonic measurements. Closed-top transducers are transducers which hermetically seal the piezoelectric membrane from exposure to air or destructive particles. Closed-top transducer are favorable in applications that are subject to harsh environmental conditions, such as exposure to outdoor elements, extreme temperature changes, and debris. As a result of the additional protection offered by closed-top transducers, a transformer-driven method is typically required to maximize distance performance.

Open-top transducers are transducers with vents or slots that expose the piezoelectric membrane to the air. Open-top transducers are favorable for controlled indoor applications to minimize the risk of the transducer becoming damaged. Open-top transducers do not require as much driving voltage as closed-top transducers to achieve maximum distance performance; therefore, a transformer is not necessary. For low-voltage driven transducers, such as open-tops, a direct-drive (or bridge-drive) method can be used as an alternative to a transformer. The direct-driven method can work on certain closed-top transducers, but the maximum achievable distance will be reduced.

### 8.2 Typical Applications

In all typical applications, the PGA460 must be paired with at least one external transducer for generating an ultrasonic echo to transmit through air and to detect the reflected echo returning from an object. The tasks of transmitting and receiving the echo can be separated into independent transducers for improved performance. In this case, the application must only detect ultrasonic echoes, no external driver components (transformer or p-channel MOSFET) are required.



## Typical Applications (接下页)

### 8.2.1 Transformer-Driven Method

图 136 shows the transformer-driven method schematic for a single transducer.

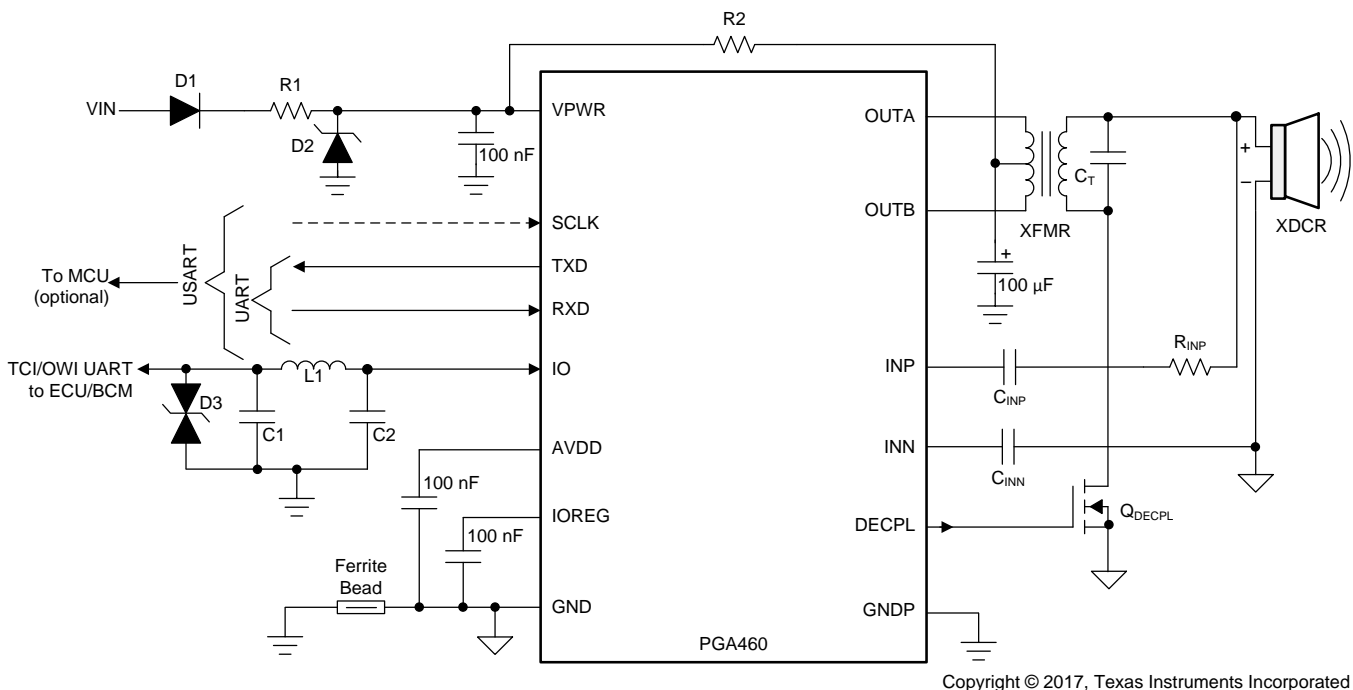

Copyright © 2017, Texas Instruments Incorporated

图 136. Transformer-Driven Method Schematic

#### 8.2.1.1 Design Requirements

For this design example, use the parameters listed in 表 100 as the input parameters.

表 100. Design Parameters

DESIGN PARAMETER	EXAMPLE VALUE
Input voltage range	6 to 18 V
Input voltage recommended	7.4 V
Transformer turns ratio	(1-2) : (2-3) : (4-6) = 1:1:8.42
Transformer driving current rating	500 mA
Transformer main voltage (4-6) rating	200 V <sub>AC</sub>
Transducer driving voltage	120 V <sub>PP</sub>
Transducer frequency	58.5 kHz
Transducer pulse count	20

#### 8.2.1.2 Detailed Design Procedure

To begin the design process, determine the following:

- Transducer
  - Transducer driving voltage
  - Transducer resonant frequency
  - Transducer pulse count
- Driver
  - Transformer turns ratio
  - Transformer saturation current
  - Transformer main voltage (4-6) rating

表 101 lists the recommended component values for typical applications.

**表 101. Recommended Component Values for Typical Applications**

DESIGNATOR	VALUE	COMMENT
R1	10 Ω (1/2 Watt)	Optional (noise reduction)
R2	100 Ω (1/2 Watt)	Optional (limit in-rush current)
R <sub>(INP)</sub>	3 kΩ (1/4 Watt)	Optional (transformer drive only. For EMI/ESD robustness)
L1	100 nH	Optional (transient suppression)
C1	100 nF	Optional (Transient suppression)
C2	100 nF	Optional (transient suppression)
C <sub>(INP)</sub>	$C_{(INP)} = \frac{21.22 \times 10^{-6}}{f_{(TRANSDUCER)}}$	
C <sub>(INN)</sub>	$C_{(INN)} = \frac{0.0024}{f_{(TRANSDUCER)}}$	
C <sub>T</sub>		Value depends on transducer and transformer used
D1	1N4007 or equivalent	Schottky diode recommended
D2	V <sub>Z</sub> < 30 V	Optional (transient suppression)
D3	V <sub>BR</sub> < 30 V	Optional (transient suppression)
XDCR		Example devices for low-frequency range: Closed top for transformer driven: muRata MA58MF14-7N, SensComp 40KPT25 Open top for direct driven: muRata MA40H1S-R, SensComp 40LPT16, Kobitone 255-400PT160-ROX
XFMR		Example devices: TDK EPCOS B78416A2232A003, muRata-Toko N1342DEA-0008BQE=P3, Mitsumi K5-R4
Q <sub>DECPL</sub>		Optional (time or temperature decoupling FET) If no decoupling FET is used, ground the XFMR and C <sub>T</sub>
Q1		Can be FETs or BJTs as discrete implementation or transistor-array package. Example devices: Example devices: FDN358P Single FET, MUN5114 single BJT
Ferrite bead	BK215HS102-T or equivalent	Optional (noise reduction). Can be substituted with 0-Ω short.

### 8.2.1.2.1 Transducer Driving Voltage

When a voltage is applied to piezoelectric ceramics, mechanical distortion is generated according to the voltage and frequency. The mechanical distortion is measured in units of sound pressure level (SPL) to indicate the volume of sound, and can be derived from a free-field microphone voltage measurement using 公式 9.

$$\text{SPL (db)} = 20 \times \log \frac{\left( \frac{V_{(\text{MIC})}}{3.4 \text{ mV}} \right)}{P_O}$$

where

- V<sub>(MIC)</sub> is the measured sensor sound pressure (mV<sub>RMS</sub>).
- P<sub>O</sub> is a referenced sound pressure of 20 μPa. (9)

The SPL does not increase indefinitely with the driving voltage. After a particular driving voltage, the amount of SPL that a transducer can generate becomes saturated. A transducer is given a maximum driving voltage specification to indicate when the maximum SPL is generated. Driving the transducer beyond the maximum driving voltage makes the ultrasonic module less power-efficient and can damage or decrease the life expectancy of the transducer.

For the detailed procedure on measuring the SPL of a transducer, refer to [PGA460 Ultrasonic Module Hardware and Software Optimization](#).

### 8.2.1.2.2 Transducer Driving Frequency

The strength of ultrasonic waves propagated into the air attenuate proportionally with distance. This attenuation is caused by diffusion, diffraction, and absorption loss as the ultrasonic energy transmits through the medium of air. As shown in 图 137, the higher the frequency of the ultrasonic wave, the larger the attenuation rate and the shorter the distance the wave reaches.



图 137. Attenuation Characteristics of Sound Pressure by Distance

An ultrasonic transducer has a fixed resonant center frequency with a typical tolerance of  $\pm 2\%$ . The lower frequency range of 30 to 80 kHz is the default operating range for common automotive and consumer applications for a step resolution of 1 cm and typical range of 30 cm to 5m. The upper frequency range of 180 to 480 kHz is reserved for high-precision industrial applications with a step resolution of 1 mm and a typical range of 5 cm to 1 m.

### 8.2.1.2.3 Transducer Pulse Count

The pulse count determines how many alternating periods are applied to the transducer by the complementary low-side drivers and determines the total width of the ultrasonic ping that was transmitted. The larger the width of the transmitted ping, the larger the width of the returned echo signature of the reflected surface and the more resolution available to set a stable threshold. A disadvantage of a large pulse count is a large ringing-decay period, which limits how detectable objects are at short distances.

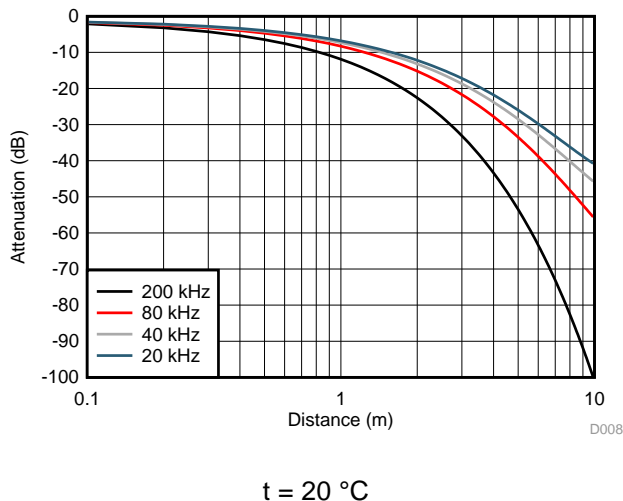
Select a pulse count based on the minimum object distance requirement. If short-distance object detection is not a priority, a high pulse count is not a concern. Certain transducers can be driven continuously while others have a limit to the maximum driving-pulse count. Refer to the specification for the selected transducer to determine if the pulse count must be limited.

### 8.2.1.2.4 Transformer Turns Ratio

A center-tap transformer is typically paired with the transducer to convert a DC voltage to a high-sinusoidal AC voltage. The center tap is a contact made to a point halfway along the primary winding of the transformer. The center tap is supplied with the DC voltage that is then multiplied on the secondary side based on the turns ratio of the transformer. 图 138 shows the typical pinout of a center-tap transformer where pin 2 is the center tap, pins 1 and 3 are connected to OUTB and OUTA, pin 4 is connected to the positive terminal of the transducer, and pin 6 is connected to ground.

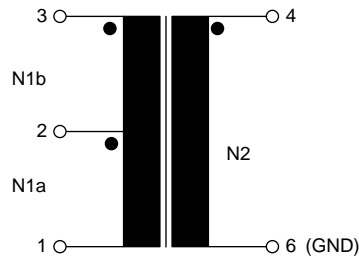

**图 138. Typical Pinout of Center-Tap Transformer for Ultrasonic Transducers**

Two modes to generate the transducer voltage using the center tap transformer are available. These modes are defined as follows:

**Push-pull** In this mode, the two internal low-side switches of the PGA460 device are used to turn current on and off in two primary coils of the center-tap transformer.

The primary coils have the same number of turns. The rate of change of current in the primary coil generates a voltage in the secondary coil of the transformer, which is connected to the transducer. The direction of current in the primary coils generates voltages of opposite polarity in the secondary coils which effectively doubles the peak-to-peak voltage in the secondary coil.

**Single-ended** In this mode, one low-side switch is used to turn current on and off in the primary of the transformer.

The rate of change of current in the primary coil generates a voltage in the secondary coil of the transformer, which is connected to the transducer. The center tap of the transformer is not required for this mode, and can be left floating. Instead, the reference voltage is connected to an outermost primary-side terminal (pin 3) and either OUTA or OUTB is connected to the other primary-side terminal (pin1).

#### 8.2.1.2.5 Transformer Saturation Current and Main Voltage Rating

Leakage inductance is caused when magnetic flux is not completely coupled between windings in a transformer. Magnetic saturation of a transformer core can be caused by excessive primary voltage, operation at too low of a frequency, by the presence of a DC current in any of the windings, or a combination of these causes. The PGA460 device can limit the primary-side driver current of the transformer internally from 50 to 500 mA. The center-tap voltage is typically referenced to the VPWR voltage. However, if the VPWR voltage is too high of a voltage on the center tap of the primary side, then the voltage must be down-regulated. If the VPWR is too low, then the voltage must be up-regulated.

#### 8.2.1.3 Application Curves

Components used: TDK EPCOS B78416A2232A003 Transformer, muRata MA58MF14-7N transducer. To minimize the ranging of the TDK EPCOS B78416A2232A003 transformer and muRata MA58MF14-7N transducer combination, place a 680pF tuning capacitor ( $C_T$ ) and 10k $\Omega$  damping resistor ( $R_{Damp}$ ) in parallel to the transducer. This will enable sub-15cm ranging depending on the pulse count, center-tap voltage, and driver current limit.

Data shown in [图 139](#) and [图 140](#) was recorded using the echo dump feature of the PGA460 device (see the [Echo Data Dump](#) section)

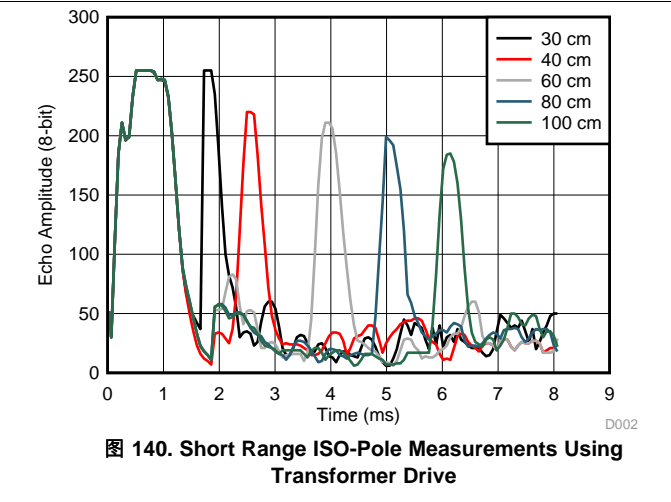
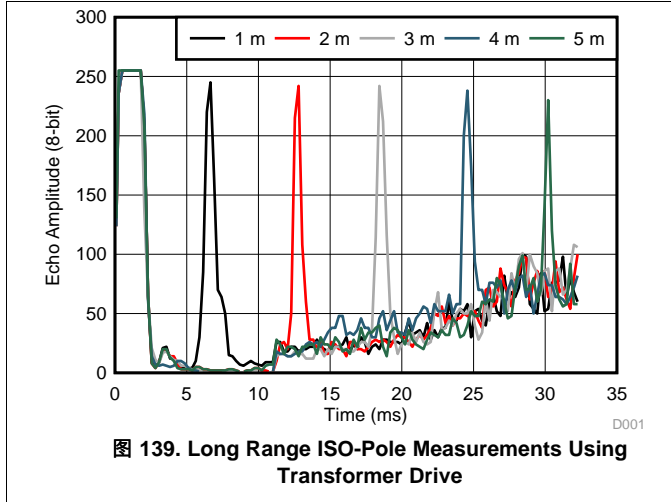

### 8.2.2 Direct-Driven (Transformer-Less) Method

The direct-driven method substitutes the traditional center-tap transformer with a bridge driver, and is suitable for plastic-shelled open-top transducers. Any open or closed top transducer can be driven directly, but the maximum amount of SPL may not be generated during transmission. The direct-driven configuration uses either a half-bridge or full-bridge gate driver to generate an alternating square wave to drive the transducer. By default, the half-bridge driver configuration is enabled to allow the use of a single transducer to transmit and receive. The PGA460 device cannot drive a single transducer in the full-bridge configuration without the addition of external components (beyond the scope of this document).. Because the low-side drivers are integrated into the PGA460 device, only one external high-side p-channel MOSFET is required. In the half-bridge configuration, one OUTx channel is used to drive the p-channel MOSFET, while the other is used to directly excite the transducer.. 图 141 shows the direct-driven method schematic for a single transducer.



图 141. Direct-Driven Method Schematic

### 8.2.2.1 Design Requirements

For this design example, use the parameters listed in 表 102 as the input parameters.

表 102. Design Parameters

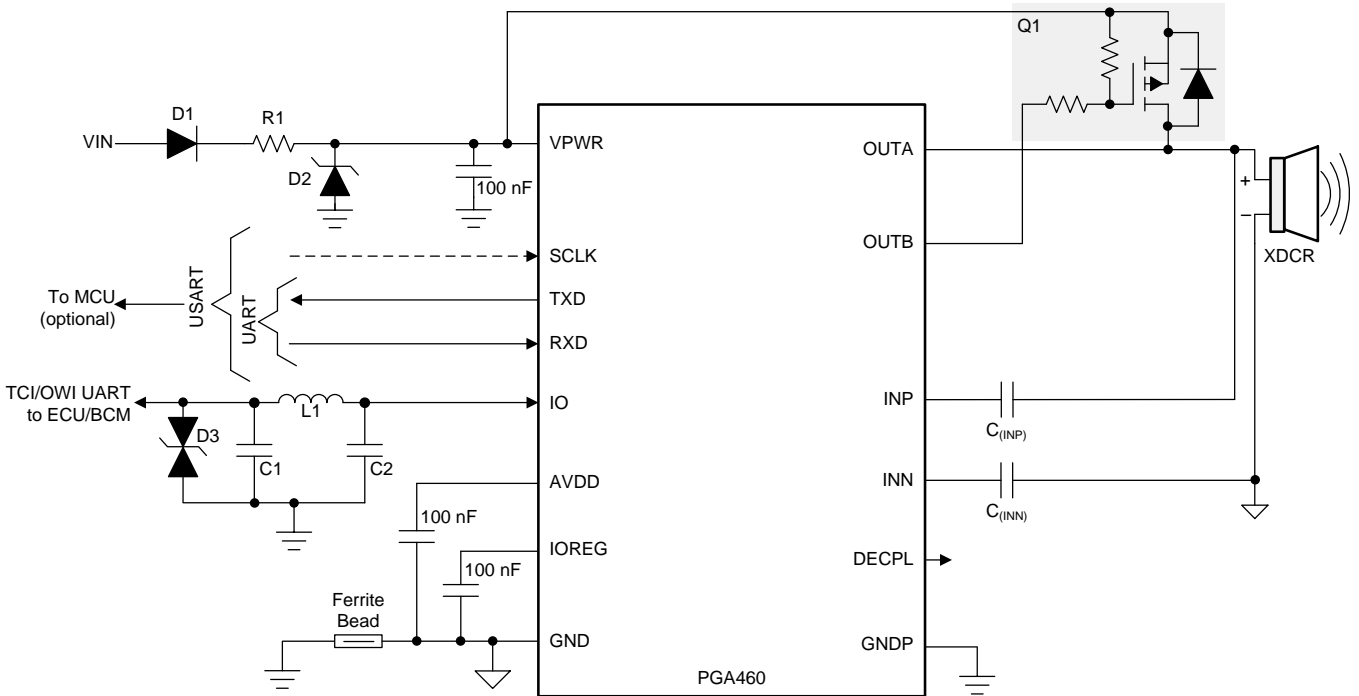
DESIGN PARAMETER	EXAMPLE VALUE
Input voltage range	6 to 7.2 V
Input voltage recommended	7.2 V
Transducer driving voltage	7.2 V <sub>PP</sub>
Transducer frequency	40 kHz
Transducer pulse count	20

### 8.2.2.2 Detailed Design Procedure

For recommended component values in typical applications, see 表 101.

### 8.2.2.3 Application Curves

Components used: Fairchild FDC6506P p-channel MOSFET, muRata MA40H1S-R transducer

Data shown in 图 139 and 图 140 was recorded using the echo dump feature of the PGA460 device (see the [Echo Data Dump](#) section)

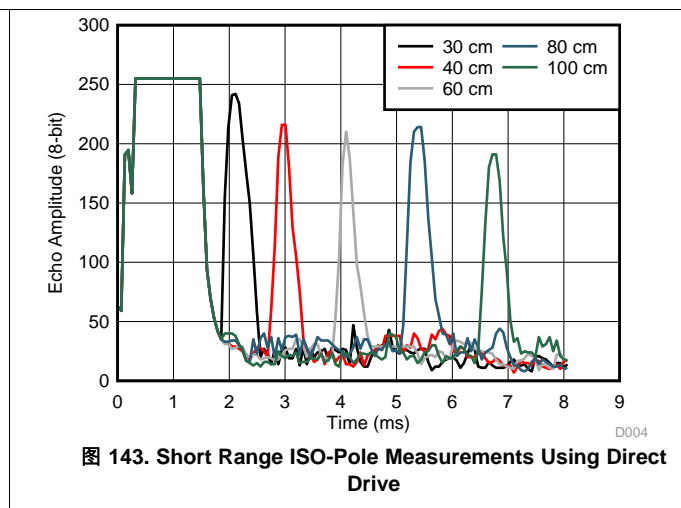
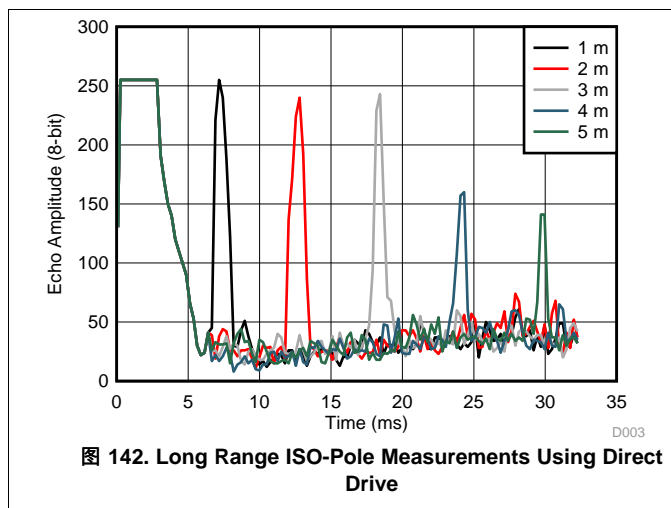

## 9 Power Supply Recommendations

The PGA460 device is designed to operate from an input voltage supply range from 6 V to 28 V. If the input supply is located more than a few inches from the PGA460 device, additional bulk capacitance may be required in addition to the ceramic bypass capacitors.

The electrolytic capacitor at the VPWR pin is intended to act as a fast discharge capacitor during the bursting stage of the PGA460 device. The center-tap transformer can be supplied with a center-tap voltage that is different than what is supplied to the VPWR pin, but must remain within specified maximum voltage rating of the OUTA and OUTB outputs. No electrolytic capacitor is required for the direct-driven method, although it is recommended for reference voltage stability, and can be less than 100  $\mu$ F.

## 10 Layout

### 10.1 Layout Guidelines

A minimum of two layers is required to accomplish a small-form factor ultrasonic module design. The layers should be separated by analog and digital signals. The pin map of the device is routed such that the power and digital signals are on the opposing side of the analog driver and receiver pins. Consider the following best practices for PGA460 device layout in order of descending priority:

- Separating the grounding types is important to reduce noise at the AFE input of the PGA460. In particular, the transducer sensor ground, supporting driver, and return-path circuitry should have a separate ground before being connected to the main ground. Separating the sensor and main grounds through a ferrite bead is best practice, but not required; a copper-trace or 0-Ω short is also acceptable when bridging grounds.
- The analog return path pins, INP and INN, are most susceptible to noise and therefore should be routed as short and directly to the transducer as possible. Ensure the INN capacitor is close to the pin to reduce the length of the ground wire.
- In applications where protection from an ESD strike on the case of the transducer is important, ground routing of the capacitor on the INN pin should be separate from the device ground and connected directly with the shortest possible trace to the connector ground.
- The analog drive pins can be high-current, high-voltage, or both and therefore the design limitation of the OUTA and OUTB pins is based on the copper trace profile. The driver pins are recommended to be as short and direct as possible when using a transformer, and driving the primary windings with a high-current limit
- The decoupling capacitors for the AVDD, IOREG, and VPWR pins should be placed as close to the pins as possible
- Any digital communication should be routed away from the analog receiver pins. The IO, TXD, RXD, and SCLK pins should be routed on the opposite side of the PCB, away from of the analog signals. When the IO pin is referenced to a high-voltage VPWR, and operating at a high-speed baud rate, the trace to the connector or master should be as direct as possible

### 10.2 Layout Example



图 144. PGA460 Layout Example

## 11 器件和文档支持

### 11.1 文档支持

#### 11.1.1 相关文档

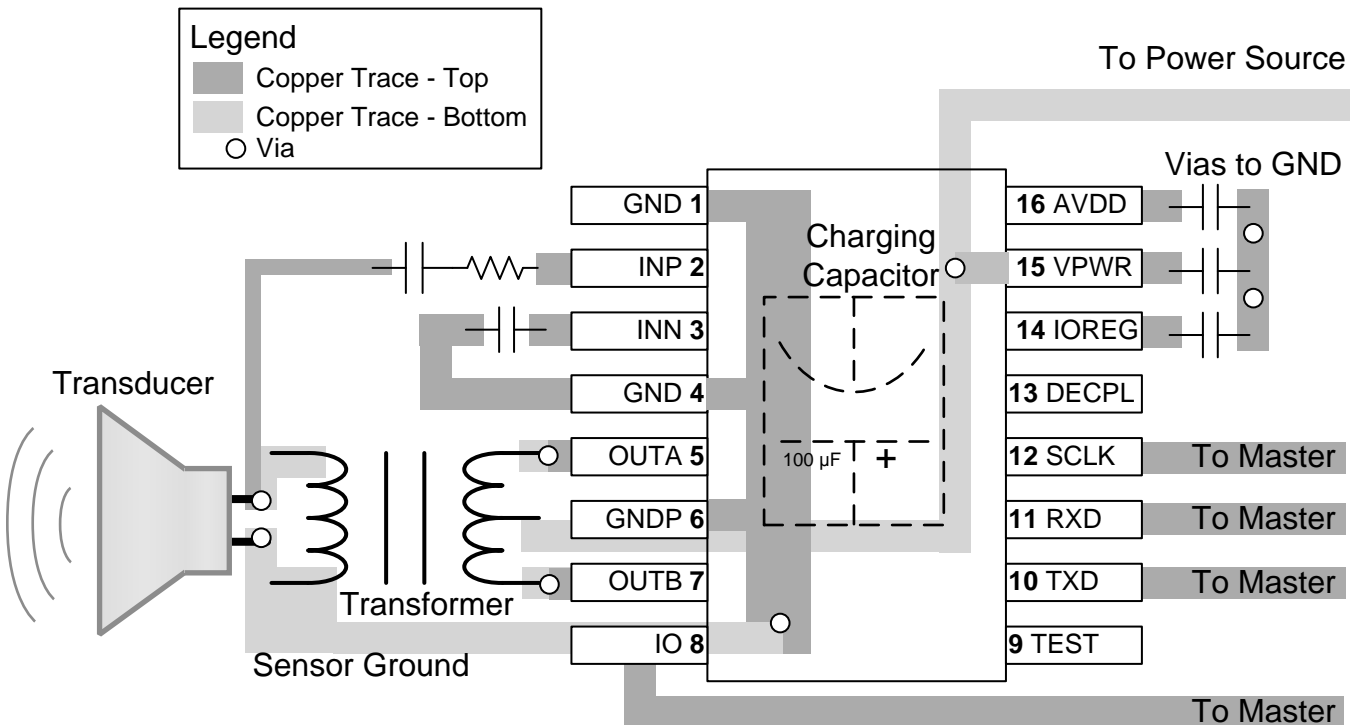
请参阅如下相关文档：

- [PGA460 常见问题解答 \(FAQ\) 和 EVM 故障排除指南 \(SLAA733\)](#)
- [PGA460 软件开发指南 \(SLAA730\)](#)
- [PGA460 超声波模块硬件和软件优化 \(SLAA732\)](#)
- [PGA460-Q1 EVM 快速入门指南 \(SLVUB17\)](#)
- [PGA460-Q1 EVM 用户指南 \(SLAU659\)](#)

#### 11.2 接收文档更新通知

要接收文档更新通知，请导航至 [TI.com.cn](http://TI.com.cn) 上的器件产品文件夹。单击右上角的 [通知我](#) 进行注册，即可每周接收产品信息更改摘要。有关更改的详细信息，请查看任何已修订文档中包含的修订历史记录。

#### 11.3 社区资源

下列链接提供到 TI 社区资源的连接。链接的内容由各个分销商“按照原样”提供。这些内容并不构成 TI 技术规范，并且不一定反映 TI 的观点；请参阅 TI 的 [《使用条款》](#)。

**TI E2E™ 在线社区** [TI 的工程师对工程师 \(E2E\) 社区](#)。此社区的创建目的在于促进工程师之间的协作。在 [e2e.ti.com](http://e2e.ti.com) 中，您可以咨询问题、分享知识、拓展思路并与同行工程师一道帮助解决问题。

**设计支持** [TI 参考设计支持](#) 可帮助您快速查找有帮助的 E2E 论坛、设计支持工具以及技术支持的联系信息。

#### 11.4 商标

E2E is a trademark of Texas Instruments.  
All other trademarks are the property of their respective owners.

#### 11.5 静电放电警告



ESD 可能会损坏该集成电路。德州仪器 (TI) 建议通过适当的预防措施处理所有集成电路。如果不遵守正确的处理措施和安装程序，可能会损坏集成电路。

ESD 的损坏小至导致微小的性能降级，大至整个器件故障。精密的集成电路可能更容易受到损坏，这是因为非常细微的参数更改都可能会导致器件与其发布的规格不相符。

#### 11.6 术语表

[SLYZ022](#) — TI 术语表。

这份术语表列出并解释术语、缩写和定义。

## 12 机械、封装和可订购信息

以下页面包含机械、封装和可订购信息。这些信息是指定器件的最新可用数据。数据如有变更，恕不另行通知，且不会对此文档进行修订。如需获取此数据表的浏览器版本，请查阅左侧的导航栏。



**PACKAGING INFORMATION**

Orderable Device	Status (1)	Package Type	Package Drawing	Pins	Package Qty	Eco Plan (2)	Lead finish/ Ball material (6)	MSL Peak Temp (3)	Op Temp (°C)	Device Marking (4/5)	Samples
PGA460TPW	ACTIVE	TSSOP	PW	16	90	RoHS & Green	NIPDAU	Level-2-260C-1 YEAR	-40 to 105	PGA460	<a href="#">Samples</a>
PGA460TPWR	ACTIVE	TSSOP	PW	16	2000	RoHS & Green	NIPDAU	Level-2-260C-1 YEAR	-40 to 105	PGA460	<a href="#">Samples</a>

(1) The marketing status values are defined as follows:

**ACTIVE:** Product device recommended for new designs.

**LIFEBUY:** TI has announced that the device will be discontinued, and a lifetime-buy period is in effect.

**NRND:** Not recommended for new designs. Device is in production to support existing customers, but TI does not recommend using this part in a new design.

**PREVIEW:** Device has been announced but is not in production. Samples may or may not be available.

**OBSOLETE:** TI has discontinued the production of the device.

(2) **RoHS:** TI defines "RoHS" to mean semiconductor products that are compliant with the current EU RoHS requirements for all 10 RoHS substances, including the requirement that RoHS substance do not exceed 0.1% by weight in homogeneous materials. Where designed to be soldered at high temperatures, "RoHS" products are suitable for use in specified lead-free processes. TI may reference these types of products as "Pb-Free".

**RoHS Exempt:** TI defines "RoHS Exempt" to mean products that contain lead but are compliant with EU RoHS pursuant to a specific EU RoHS exemption.

**Green:** TI defines "Green" to mean the content of Chlorine (Cl) and Bromine (Br) based flame retardants meet JS709B low halogen requirements of <=1000ppm threshold. Antimony trioxide based flame retardants must also meet the <=1000ppm threshold requirement.

(3) MSL, Peak Temp. - The Moisture Sensitivity Level rating according to the JEDEC industry standard classifications, and peak solder temperature.

(4) There may be additional marking, which relates to the logo, the lot trace code information, or the environmental category on the device.

(5) Multiple Device Markings will be inside parentheses. Only one Device Marking contained in parentheses and separated by a "~" will appear on a device. If a line is indented then it is a continuation of the previous line and the two combined represent the entire Device Marking for that device.

(6) Lead finish/Ball material - Orderable Devices may have multiple material finish options. Finish options are separated by a vertical ruled line. Lead finish/Ball material values may wrap to two lines if the finish value exceeds the maximum column width.

**Important Information and Disclaimer:**The information provided on this page represents TI's knowledge and belief as of the date that it is provided. TI bases its knowledge and belief on information provided by third parties, and makes no representation or warranty as to the accuracy of such information. Efforts are underway to better integrate information from third parties. TI has taken and continues to take reasonable steps to provide representative and accurate information but may not have conducted destructive testing or chemical analysis on incoming materials and chemicals. TI and TI suppliers consider certain information to be proprietary, and thus CAS numbers and other limited information may not be available for release.

In no event shall TI's liability arising out of such information exceed the total purchase price of the TI part(s) at issue in this document sold by TI to Customer on an annual basis.



**TAPE AND REEL INFORMATION**

**QUADRANT ASSIGNMENTS FOR PIN 1 ORIENTATION IN TAPE**

\*All dimensions are nominal

Device	Package Type	Package Drawing	Pins	SPQ	Reel Diameter (mm)	Reel Width W1 (mm)	A0 (mm)	B0 (mm)	K0 (mm)	P1 (mm)	W (mm)	Pin1 Quadrant
PGA460TPWR	TSSOP	PW	16	2000	330.0	12.4	6.9	5.6	1.6	8.0	12.0	Q1

**TAPE AND REEL BOX DIMENSIONS**

\*All dimensions are nominal

Device	Package Type	Package Drawing	Pins	SPQ	Length (mm)	Width (mm)	Height (mm)
PGA460TPWR	TSSOP	PW	16	2000	350.0	350.0	43.0

**TUBE**

\*All dimensions are nominal

Device	Package Name	Package Type	Pins	SPQ	L (mm)	W (mm)	T (μm)	B (mm)
PGA460TPW	PW	TSSOP	16	90	530	10.2	3600	3.5



4220204/A 02/2017

NOTES:

1. All linear dimensions are in millimeters. Any dimensions in parenthesis are for reference only. Dimensioning and tolerancing per ASME Y14.5M.
2. This drawing is subject to change without notice.
3. This dimension does not include mold flash, protrusions, or gate burrs. Mold flash, protrusions, or gate burrs shall not exceed 0.15 mm per side.
4. This dimension does not include interlead flash. Interlead flash shall not exceed 0.25 mm per side.
5. Reference JEDEC registration MO-153.

# EXAMPLE BOARD LAYOUT

PW0016A

TSSOP - 1.2 mm max height

SMALL OUTLINE PACKAGE



LAND PATTERN EXAMPLE  
EXPOSED METAL SHOWN  
SCALE: 10X



4220204/A 02/2017

NOTES: (continued)

- 6. Publication IPC-7351 may have alternate designs.
- 7. Solder mask tolerances between and around signal pads can vary based on board fabrication site.

# EXAMPLE STENCIL DESIGN

PW0016A

TSSOP - 1.2 mm max height

SMALL OUTLINE PACKAGE



SOLDER PASTE EXAMPLE  
BASED ON 0.125 mm THICK STENCIL  
SCALE: 10X

4220204/A 02/2017

NOTES: (continued)

8. Laser cutting apertures with trapezoidal walls and rounded corners may offer better paste release. IPC-7525 may have alternate design recommendations.
9. Board assembly site may have different recommendations for stencil design.



## 重要声明和免责声明

TI“按原样”提供技术和可靠性数据（包括数据表）、设计资源（包括参考设计）、应用或其他设计建议、网络工具、安全信息和其他资源，不保证没有瑕疵且不做任何明示或暗示的担保，包括但不限于对适销性、某特定用途方面的适用性或不侵犯任何第三方知识产权的暗示担保。

这些资源可供使用 TI 产品进行设计的熟练开发人员使用。您将自行承担以下全部责任：(1) 针对您的应用选择合适的 TI 产品，(2) 设计、验证并测试您的应用，(3) 确保您的应用满足相应标准以及任何其他功能安全、信息安全、监管或其他要求。

这些资源如有变更，恕不另行通知。TI 授权您仅可将这些资源用于研发本资源所述的 TI 产品的应用。严禁对这些资源进行其他复制或展示。您无权使用任何其他 TI 知识产权或任何第三方知识产权。您应全额赔偿因在这些资源的使用中对 TI 及其代表造成的任何索赔、损害、成本、损失和债务，TI 对此概不负责。

TI 提供的产品受 [TI 的销售条款](#) 或 [ti.com](#) 上其他适用条款/TI 产品随附的其他适用条款的约束。TI 提供这些资源并不会扩展或以其他方式更改 TI 针对 TI 产品发布的适用的担保或担保免责声明。

TI 反对并拒绝您可能提出的任何其他或不同的条款。

邮寄地址：Texas Instruments, Post Office Box 655303, Dallas, Texas 75265

Copyright © 2022，德州仪器 (TI) 公司

## X-ON Electronics

Largest Supplier of Electrical and Electronic Components

*Click to view similar products for [Analog Front End - AFE category](#):*

*Click to view products by [Texas Instruments manufacturer](#):*

Other Similar products are found below :

[ISL98001CQZ-275](#) [X98014L128-3.3](#) [AW86862CSR](#) [BL0910](#) [RN2025\(C64\),E05](#) [BL0906](#) [BL6513](#) [CS5480SG-INZ](#) [RN8209G\(C\)](#) [RN8208G](#)  
[ADS58J63IRMPR](#) [ADC32RF80IRRHR](#) [AFE4460YBGT](#) [ADS1198CPAGR](#) [TC500ACPE](#) [MCP3914A1-E/MV](#) [MCP3914A1T-E/MV](#)  
[ISL51002CQZ-165](#) [ISL98001CQZ-140](#) [PGA460TPWQ1](#) [AFE5809ZCF](#) [TC500CPE](#) [ADE9078ACPZ](#) [AD73360ARZ-REEL7](#)  
[TC500ACOE713](#) [MCP3919A1-E/MQ](#) [AFE4900YZT](#) [MCP3918A1-E/ML](#) [AFE58JD18ZBV](#) [ADE9078ACPZ-RL](#) [ADAS1000-2BSTZ](#)  
[ADAS1000-4BSTZ](#) [ADPD1080WBCPZR7](#) [AD73311ARSZ](#) [AD8232ACPZ-R7](#) [AD8233ACBZ-R7](#) [AD9671KBCZ](#) [AD9826KRSZRL](#)  
[ADA4350ARUZ-R7](#) [AD9847AKSTZ](#) [ADPD4100BCBZR7](#) [ADPD4101BCBZR7](#) [BL6552](#) [AFE5808ZCF](#) [WM8199SCDS/V](#)  
[WM8234GEFL/V](#) [WM8235GEFLV](#) [MCP3913A1T-E/SS](#) [ATM90E26-YU-B](#) [ATM90E26-YU-R](#)