

FEATURES

- Available in the Texas Instruments NanoFree™ Package
- Operates at 0.8 V to 2.7 V
- Sub-1-V Operable
- Max t_{pd} of 0.5 ns at 1.8 V
- Low Power Consumption, 10 μ A at 2.7 V
- High On-Off Output Voltage Ratio
- High Degree of Linearity
- Latch-Up Performance Exceeds 100 mA Per JESD 78, Class II
- ESD Performance Tested Per JESD 22
 - 2000-V Human-Body Model (A114-B, Class II)
 - 200-V Machine Model (A115-A)
 - 1000-V Charged-Device Model (C101)

DCT OR DCU PACKAGE
(TOP VIEW)

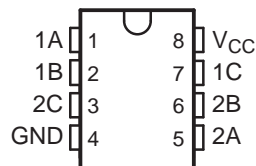

YZP PACKAGE
(BOTTOM VIEW)

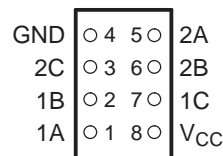

DESCRIPTION/ORDERING INFORMATION

This dual analog switch is operational at 0.8-V to 2.7-V V_{CC} , but is designed specifically for 1.1-V to 2.7-V V_{CC} operation.

The SN74AUC2G66 can handle both analog and digital signals. It permits signals with amplitudes of up to 2.7-V (peak) to be transmitted in either direction.

NanoFree™ package technology is a major breakthrough in IC packaging concepts, using the die as the package.

Applications include signal gating, chopping, modulation or demodulation (modem), and signal multiplexing for analog-to-digital and digital-to-analog conversion systems.

ORDERING INFORMATION

T_A	PACKAGE ⁽¹⁾		ORDERABLE PART NUMBER	TOP-SIDE MARKING ⁽²⁾
–40°C to 85°C	NanoFree™ – WCSP (DSBGA) 0.23-mm Large Bump – YZP (Pb-free)	Reel of 3000	SN74AUC2G66YZPR	__ _U6_
	SSOP – DCT	Reel of 3000	SN74AUC2G66DCTR	U66__ _
	VSSOP – DCU	Reel of 3000	SN74AUC2G66DCUR	U66_

(1) Package drawings, standard packing quantities, thermal data, symbolization, and PCB design guidelines are available at www.ti.com/sc/package.

(2) DCT: The actual top-side marking has three additional characters that designate the year, month, and assembly/test site.
DCU: The actual top-side marking has one additional character that designates the assembly/test site.

YZP: The actual top-side marking has three preceding characters to denote year, month, and sequence code, and one following character to designate the assembly/test site. Pin 1 identifier indicates solder-bump composition (1 = SnPb, • = Pb-free).

FUNCTION TABLE

CONTROL INPUT (C)	SWITCH
L	OFF
H	ON



Please be aware that an important notice concerning availability, standard warranty, and use in critical applications of Texas Instruments semiconductor products and disclaimers thereto appears at the end of this data sheet.

NanoFree is a trademark of Texas Instruments.

SN74AUC2G66 DUAL BILATERAL ANALOG SWITCH

SCES507A–NOVEMBER 2003–REVISED JANUARY 2007

LOGIC DIAGRAM (POSITIVE LOGIC)

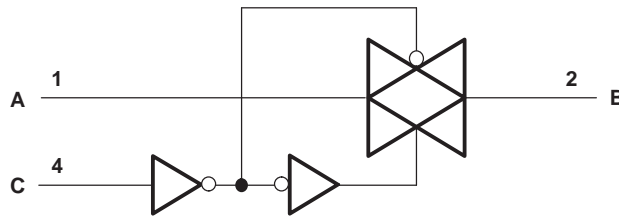

Absolute Maximum Ratings⁽¹⁾

over operating free-air temperature range (unless otherwise noted)

		MIN	MAX	UNIT
V_{CC}	Supply voltage range ⁽²⁾	-0.5	3.6	V
V_I	Input voltage range ⁽²⁾⁽³⁾	-0.5	3.6	V
$V_{I/O}$	Switch I/O voltage range ⁽²⁾⁽³⁾	-0.5	$V_{CC} + 0.5$	V
I_{IK}	Control input clamp current	$V_I < 0$		-50 mA
$I_{I/OK}$	I/O port diode current	$V_{I/O} < 0$ or $V_{I/O} > V_{CC}$		± 50 mA
I_T	On-state switch current	$V_{I/O} = 0$ to V_{CC}		± 50 mA
	Continuous current through V_{CC} or GND			± 100 mA
θ_{JA}	Package thermal impedance ⁽⁴⁾	DCT package		220
		DCU package		227
		YZP package		102
T_{stg}	Storage temperature range	-65	150	$^{\circ}\text{C}$

- (1) Stresses beyond those listed under "absolute maximum ratings" may cause permanent damage to the device. These are stress ratings only, and functional operation of the device at these or any other conditions beyond those indicated under "recommended operating conditions" is not implied. Exposure to absolute-maximum-rated conditions for extended periods may affect device reliability.
- (2) All voltages are with respect to ground unless otherwise specified.
- (3) The input negative-voltage and output voltage ratings may be exceeded if the input and output current ratings are observed.
- (4) The package thermal impedance is calculated in accordance with JESD 51-7.

Recommended Operating Conditions⁽¹⁾

		MIN	MAX	UNIT
V _{CC}	Supply voltage	0.8	2.7	V
V _{IH}	High-level input voltage	V _{CC} = 0.8 V	V _{CC}	V
		V _{CC} = 1.1 V to 1.95 V	0.65 × V _{CC}	
		V _{CC} = 2.3 V to 2.7 V	1.7	
V _{IL}	Low-level input voltage	V _{CC} = 0.8 V	0	V
		V _{CC} = 1.1 V to 1.95 V	0.35 × V _{CC}	
		V _{CC} = 2.3 V to 2.7 V	0.7	
V _{I/O}	I/O port voltage	0	V _{CC}	V
V _I	Control input voltage	0	3.6	V
Δt/Δv	Input transition rise or fall rate	V _{CC} = 0.8 V to 1.65 V ⁽²⁾	20	ns/V
		V _{CC} = 1.65 V to 2.3 V ⁽³⁾	20	
		V _{CC} = 2.3 V to 2.7 V ⁽³⁾	20	
T _A	Operating free-air temperature	−40	85	°C

(1) All unused inputs of the device must be held at V_{CC} or GND to ensure proper device operation. Refer to the TI application report, *Implications of Slow or Floating CMOS Inputs*, literature number SCBA004.

(2) The data was taken at C_L = 15 pF, R_L = 2 kΩ (see Figure 1).

(3) The data was taken at C_L = 30 pF, R_L = 500 Ω (see Figure 1).

Electrical Characteristics

over recommended operating free-air temperature range (unless otherwise noted)

PARAMETER	TEST CONDITIONS	V _{CC}	MIN	TYP ⁽¹⁾	MAX	UNIT
r _{on}	V _I = V _{CC} or GND, V _C = V _{IH} (see Figure 1 and Figure 2)	I _S = 4 mA	1.1 V	17	40	Ω
			1.65 V	7	20	
		I _S = 8 mA	2.3 V	4	15	
r _{on(p)}	V _I = V _{CC} to GND, V _C = V _{IH} (see Figure 1 and Figure 2)	I _S = 4 mA	1.1 V	131	180	Ω
			1.65 V	32	80	
		I _S = 8 mA	2.3 V	15	20	
Δr _{on}	V _I = V _{CC} to GND, V _C = V _{IH} (see Figure 1 and Figure 2)	I _S = 4 mA	1.1 V		3	Ω
			1.65 V		1	
		I _S = 8 mA	2.3 V		1	
I _{S(off)}	V _I = V _{CC} and V _O = GND, or V _I = GND and V _O = V _{CC} , V _C = V _{IL} (see Figure 3)	2.7 V		±1	±0.1 ⁽²⁾	μA
I _{S(on)}	V _I = V _{CC} or GND, V _C = V _{IH} , V _O = Open (see Figure 4)	2.7 V		±1	±0.1 ⁽²⁾	μA
I _I	V _I = V _{CC} or GND	0 to 2.7 V			±5	μA
I _{CC}	V _I = V _{CC} or GND, I _O = 0	0.8 V to 2.7 V			10	μA
C _{ic}		2.5 V		2.5		pF
C _{io(off)}		2.5 V		3		pF
C _{io(on)}		2.5 V		7		pF

(1) t_a = 25°C

(2) The data was taken at C_L = 15 pF, R_L = 2 kΩ (see Figure 1).

SN74AUC2G66

DUAL BILATERAL ANALOG SWITCH

SCE5507A–NOVEMBER 2003–REVISED JANUARY 2007

Switching Characteristics

over recommended operating free-air temperature range, $C_L = 15$ pF (unless otherwise noted) (see [Figure 5](#))

PARAMETER	FROM (INPUT)	TO (OUTPUT)	$V_{CC} = 0.8$ V	$V_{CC} = 1.2$ V ± 0.1 V	$V_{CC} = 1.5$ V ± 0.1 V	$V_{CC} = 1.8$ V ± 0.15 V	$V_{CC} = 2.5$ V ± 0.2 V	UNIT
			TYP	MIN MAX	MIN MAX	MIN TYP MAX	MIN MAX	
$t_{pd}^{(1)}$	A or B	B or A	1	0.6	0.5	0.5	0.4	ns
t_{en}	C	A or B	5	0.5 3	0.5 2.1	0.5 0.9 1.6	0.5 1.4	ns
t_{dis}	C	A or B	5.3	0.5 4	0.5 3	0.5 2.6 3.3	0.5 2.7	ns

(1) The propagation delay is the calculated RC time constant of the typical on-state resistance of the switch and the specified load capacitance when driven by an ideal voltage source (zero output impedance).

Switching Characteristics

over recommended operating free-air temperature range, $C_L = 30$ pF (unless otherwise noted) (see [Figure 5](#))

PARAMETER	FROM (INPUT)	TO (OUTPUT)	$V_{CC} = 1.8$ V ± 0.15 V			$V_{CC} = 2.5$ V ± 0.2 V		UNIT
			MIN	TYP	MAX	MIN	MAX	
$t_{pd}^{(1)}$	A or B	B or A			0.7		0.7	ns
t_{en}	C	A or B	0.5	1.6	2.7	0.5	2.3	ns
t_{dis}	C	A or B	0.5	2.7	3.4	0.5	2	ns

(1) The propagation delay is the calculated RC time constant of the typical on-state resistance of the switch and the specified load capacitance when driven by an ideal voltage source (zero output impedance).

Analog Switch Characteristics

$T_A = 25^\circ\text{C}$

PARAMETER	FROM (INPUT)	TO (OUTPUT)	TEST CONDITIONS	V_{CC}	TYP	UNIT
Frequency response (switch ON)	A or B	B or A	$C_L = 50$ pF, $R_L = 600$ Ω , $f_{in} =$ sine wave (see Figure 6)	0.8 V	101	MHz
				1.1 V	150	
				1.4 V	175	
				1.65 V	250	
				2.3 V	400	
			$C_L = 5$ pF, $R_L = 50$ Ω , $f_{in} =$ sine wave (see Figure 6)	0.8 V	450	
				1.1 V	>500	
				1.4 V	>500	
				1.65 V	>500	
				2.3 V	>500	
Crosstalk (between switches)	A or B	B or A	$C_L = 50$ pF, $R_L = 600$ Ω , $f_{in} = 1$ MHz (sine wave) (see Figure 7)	0.8 V	-60	dB
				1.1 V	-60	
				1.4 V	-60	
				1.65 V	-60	
				2.3 V	-60	
			$C_L = 5$ pF, $R_L = 50$ Ω , $f_{in} = 1$ MHz (sine wave) (see Figure 7)	0.8 V	-65	
				1.1 V	-65	
				1.4 V	-65	
				1.65 V	-65	
				2.3 V	-65	

Analog Switch Characteristics (continued)

$T_A = 25^\circ\text{C}$

PARAMETER	FROM (INPUT)	TO (OUTPUT)	TEST CONDITIONS	V_{CC}	TYP	UNIT
Crosstalk (control input to signal output)	C	A or B	$C_L = 50\text{ pF}$, $R_L = 600\ \Omega$, $f_{in} = 1\text{ MHz}$ (square wave) (see Figure 8)	0.8 V	9	mV
				1.1 V	14	
				1.4 V	15	
				1.65 V	16	
				2.3 V	20	
Feedthrough attenuation (switch OFF)	A or B	B or A	$C_L = 50\text{ pF}$, $R_L = 600\ \Omega$, $f_{in} = 1\text{ MHz}$ (sine wave) (see Figure 9)	0.8 V	-50	dB
				1.1 V	-50	
				1.4 V	-50	
				1.65 V	-50	
				2.3 V	-50	
			$C_L = 5\text{ pF}$, $R_L = 50\ \Omega$, $f_{in} = 1\text{ MHz}$ (sine wave) (see Figure 9)	0.8 V	-60	
				1.1 V	-60	
				1.4 V	-60	
				1.65 V	-60	
				2.3 V	-60	
Sine-wave distortion	A or B	B or A	$C_L = 50\text{ pF}$, $R_L = 10\text{ k}\Omega$, $f_{in} = 1\text{ kHz}$ (sine wave) (see Figure 10)	0.8 V	7	%
				1.1 V	0.256	
				1.4 V	0.04	
				1.65 V	0.03	
				2.3 V	0.01	
	A or B	B or A	$C_L = 50\text{ pF}$, $R_L = 10\text{ k}\Omega$, $f_{in} = 10\text{ kHz}$ (sine wave) (see Figure 10)	0.8 V	3.7	
				1.1 V	0.4	
				1.4 V	0.04	
				1.65 V	0.02	
				2.3 V	0.02	

Operating Characteristics

$T_A = 25^\circ\text{C}$

PARAMETER	TEST CONDITIONS	$V_{CC} = 0.8\text{ V}$	$V_{CC} = 1.2\text{ V}$	$V_{CC} = 1.5\text{ V}$	$V_{CC} = 1.8\text{ V}$	$V_{CC} = 2.5\text{ V}$	UNIT
		TYP	TYP	TYP	TYP	TYP	
C_{pd} Power dissipation capacitance	$f = 10\text{ MHz}$	2.5	2.5	2.5	2.5	2.5	pF

PARAMETER MEASUREMENT INFORMATION

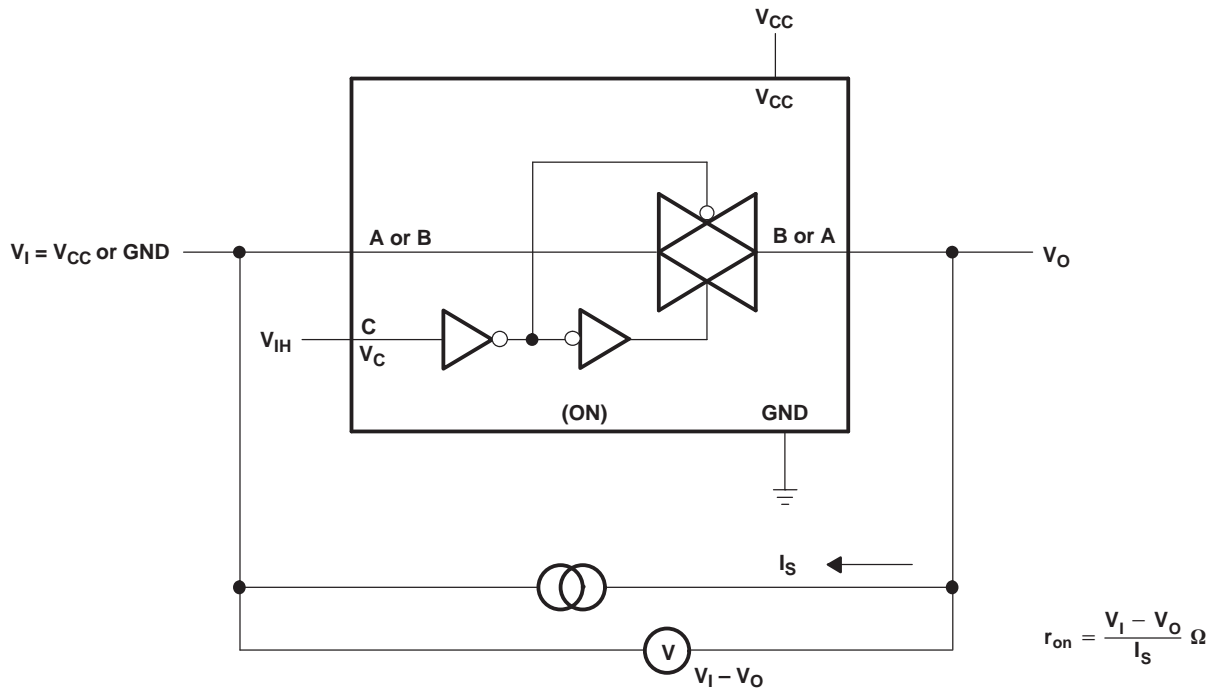

Figure 1. On-State Resistance Test Circuit

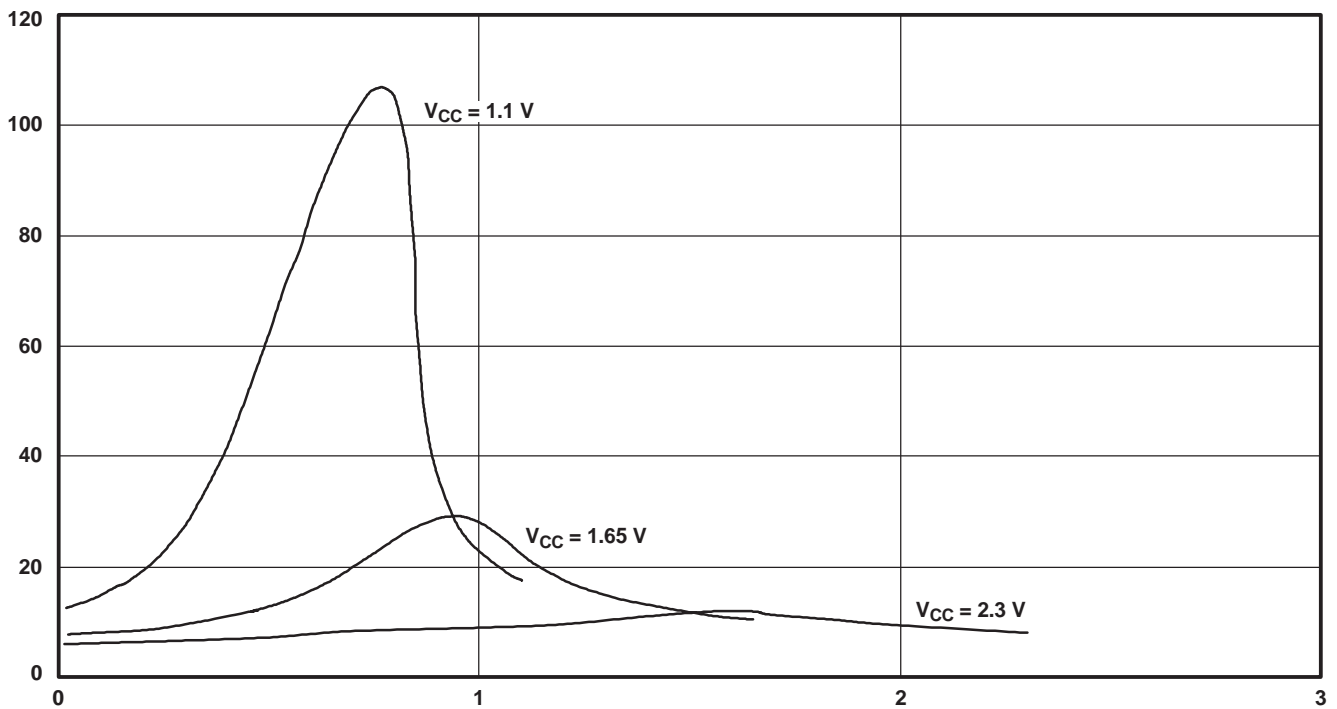

Figure 2. Typical r_{on} as a Function of Voltage (V_I) for $V_I = 0$ to V_{CC}

PARAMETER MEASUREMENT INFORMATION

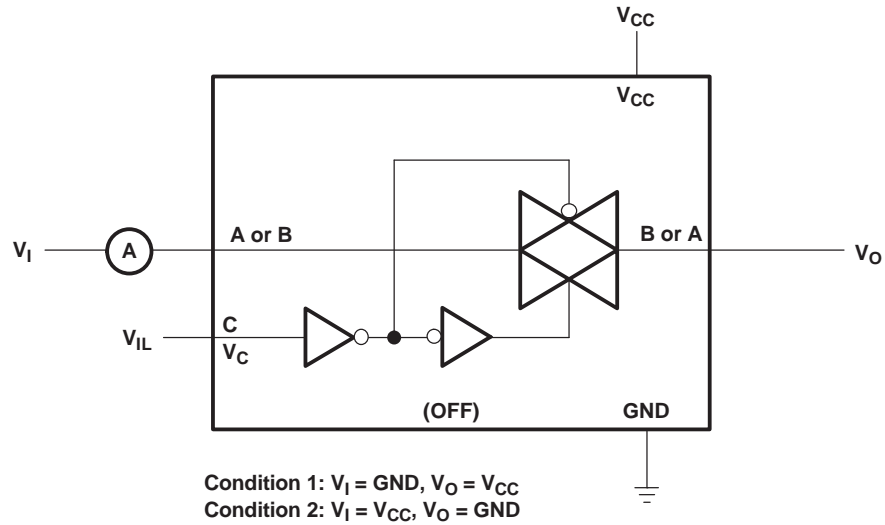

Figure 3. Off-State Switch Leakage-Current Test Circuit

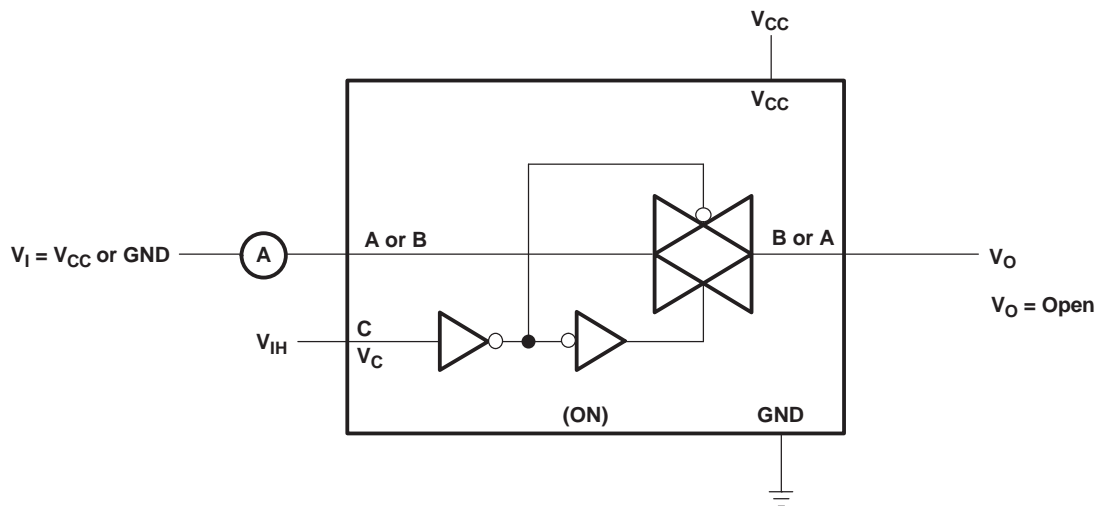
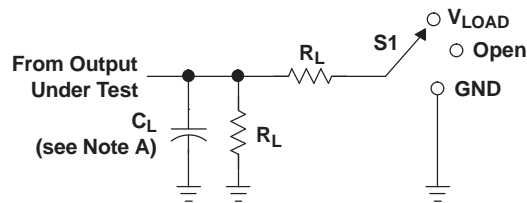

Figure 4. On-State Leakage-Current Test Circuit

PARAMETER MEASUREMENT INFORMATION



TEST	S1
t_{PLH}/t_{PHL}	Open
t_{PLZ}/t_{PZL}	V_{LOAD}
t_{PHZ}/t_{PZH}	GND

LOAD CIRCUIT

V_{CC}	INPUTS		V_M	V_{LOAD}	C_L	R_L	V_{Δ}
	V_I	t_r/t_f					
0.8 V	V_{CC}	≤ 2 ns	$V_{CC}/2$	$2 \times V_{CC}$	15 pF	2 k Ω	0.1 V
1.2 V \pm 0.1 V	V_{CC}	≤ 2 ns	$V_{CC}/2$	$2 \times V_{CC}$	15 pF	2 k Ω	0.1 V
1.5 V \pm 0.1 V	V_{CC}	≤ 2 ns	$V_{CC}/2$	$2 \times V_{CC}$	15 pF	2 k Ω	0.1 V
1.8 V \pm 0.15 V	V_{CC}	≤ 2 ns	$V_{CC}/2$	$2 \times V_{CC}$	15 pF	2 k Ω	0.15 V
2.5 V \pm 0.2 V	V_{CC}	≤ 2 ns	$V_{CC}/2$	$2 \times V_{CC}$	15 pF	2 k Ω	0.15 V
1.8 V \pm 0.15 V	V_{CC}	≤ 2 ns	$V_{CC}/2$	$2 \times V_{CC}$	30 pF	1 k Ω	0.15 V
2.5 V \pm 0.2 V	V_{CC}	≤ 2 ns	$V_{CC}/2$	$2 \times V_{CC}$	30 pF	500 Ω	0.15 V

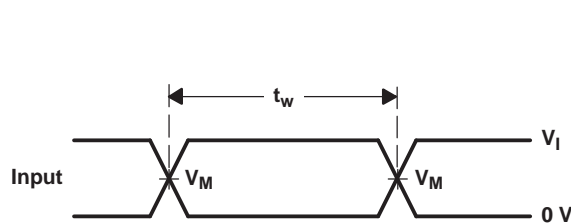

VOLTAGE WAVEFORMS
PULSE DURATION

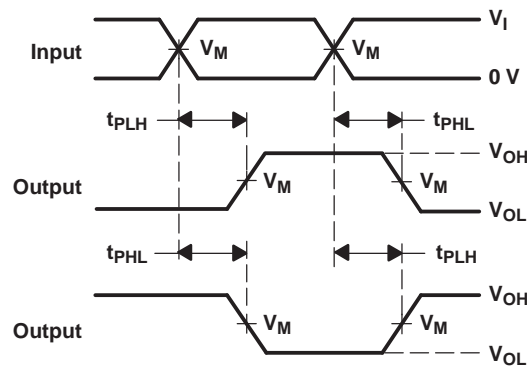

VOLTAGE WAVEFORMS
PROPAGATION DELAY TIMES
INVERTING AND NONINVERTING OUTPUTS

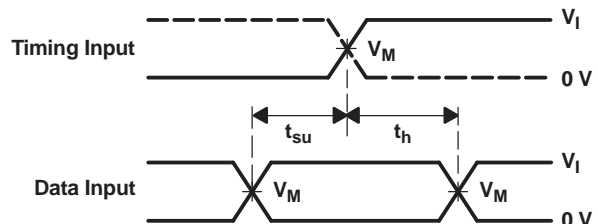

VOLTAGE WAVEFORMS
SETUP AND HOLD TIMES

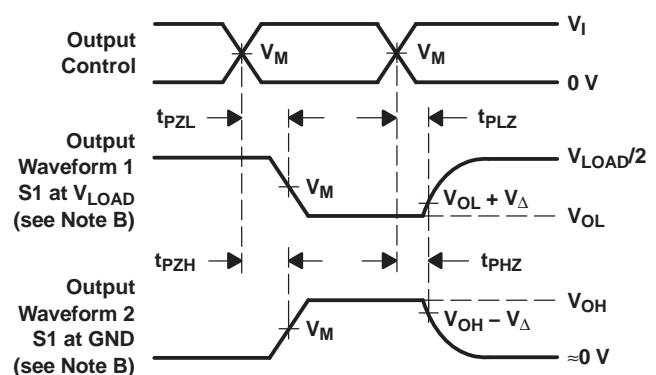

VOLTAGE WAVEFORMS
ENABLE AND DISABLE TIMES
LOW- AND HIGH-LEVEL ENABLING

- NOTES:
- A. C_L includes probe and jig capacitance.
 - B. Waveform 1 is for an output with internal conditions such that the output is low, except when disabled by the output control. Waveform 2 is for an output with internal conditions such that the output is high, except when disabled by the output control.
 - C. All input pulses are supplied by generators having the following characteristics: PRR \leq 10 MHz, $Z_O = 50 \Omega$, slew rate \geq 1 V/ns.
 - D. The outputs are measured one at a time, with one transition per measurement.
 - E. t_{PLZ} and t_{PHZ} are the same as t_{dis} .
 - F. t_{PZL} and t_{PZH} are the same as t_{en} .
 - G. t_{PLH} and t_{PHL} are the same as t_{pd} .
 - H. All parameters and waveforms are not applicable to all devices.

Figure 5. Load Circuit and Voltage Waveforms

PARAMETER MEASUREMENT INFORMATION

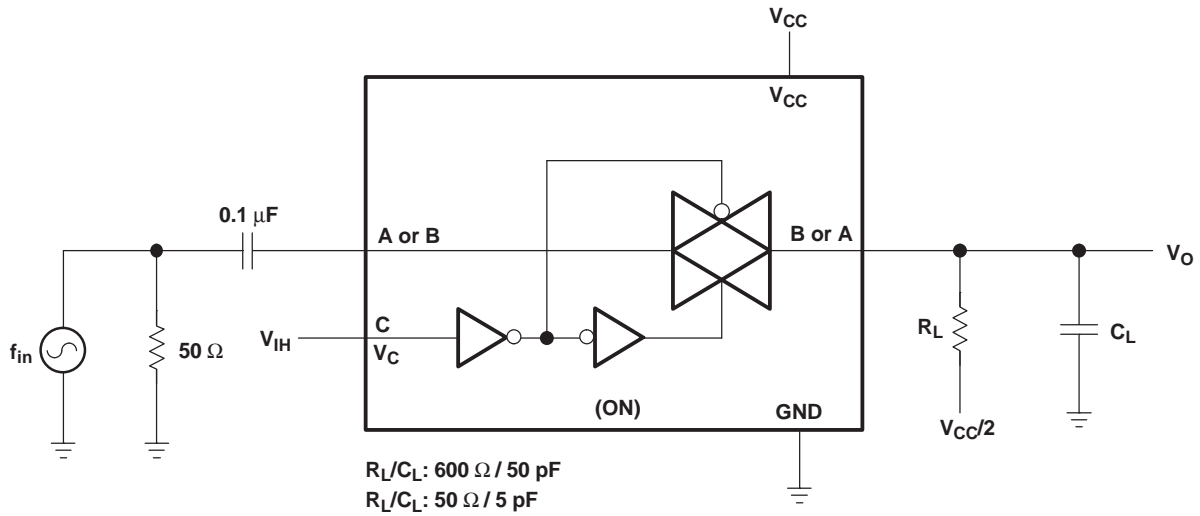

Figure 6. Frequency Response (Switch ON)

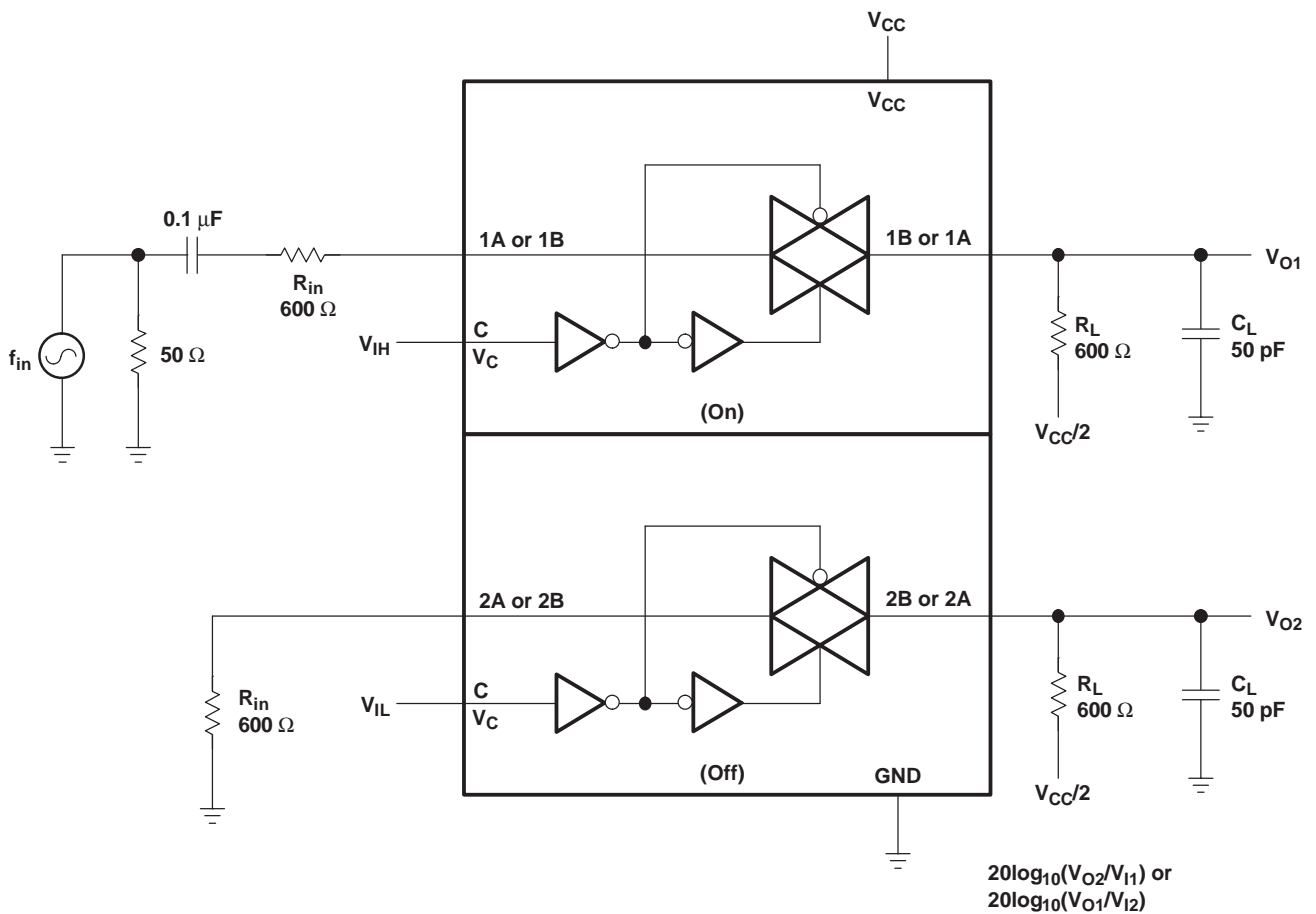

Figure 7. Crosstalk (Between Switches)

PARAMETER MEASUREMENT INFORMATION

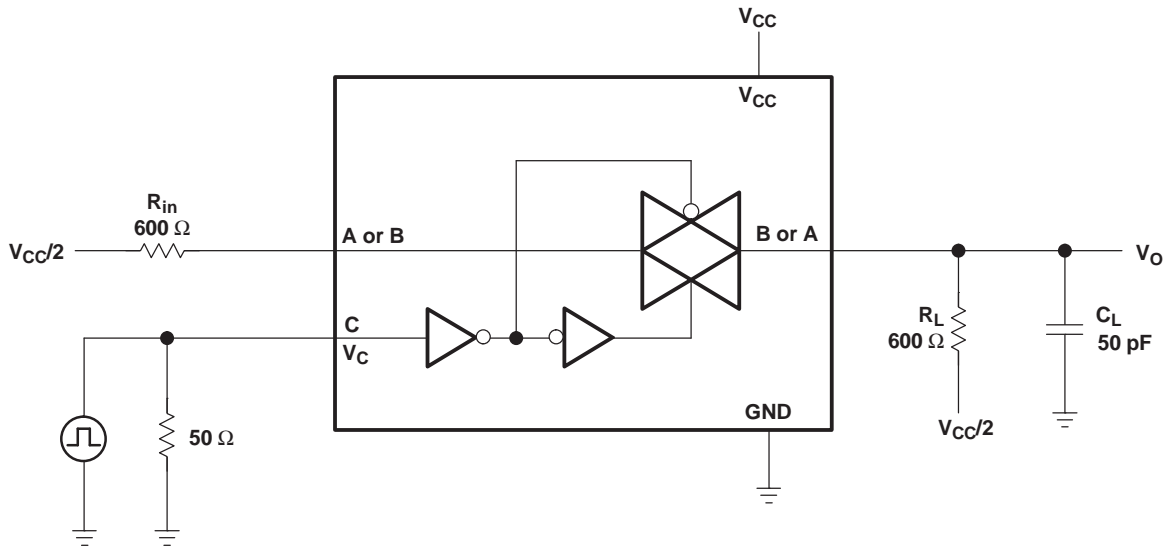

Figure 8. Crosstalk (Control Input – Switch Output)

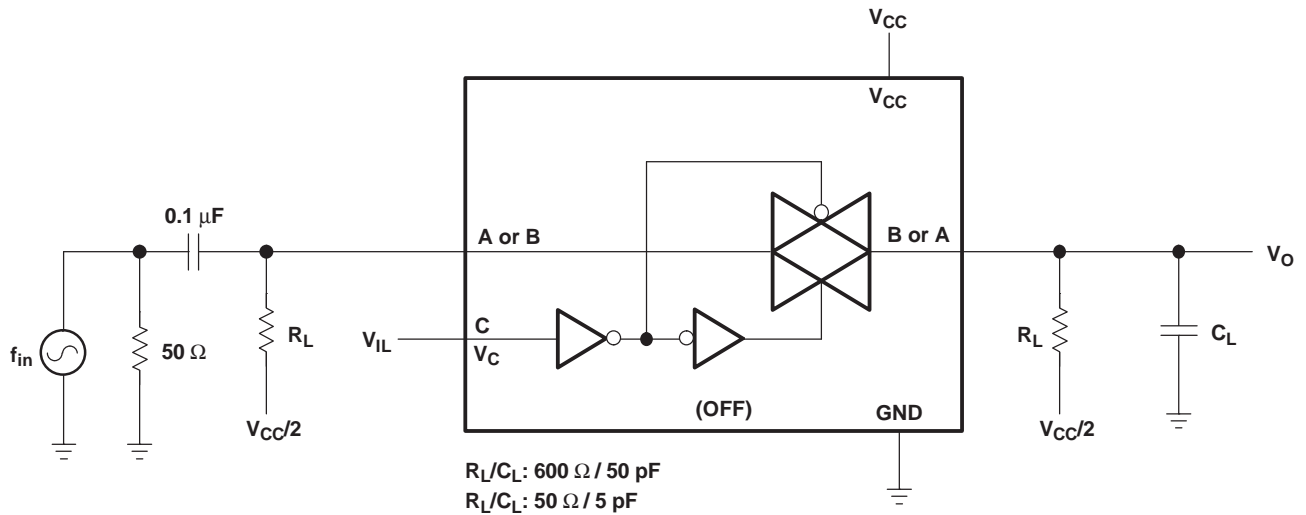

Figure 9. Feedthrough, Switch Off

PARAMETER MEASUREMENT INFORMATION

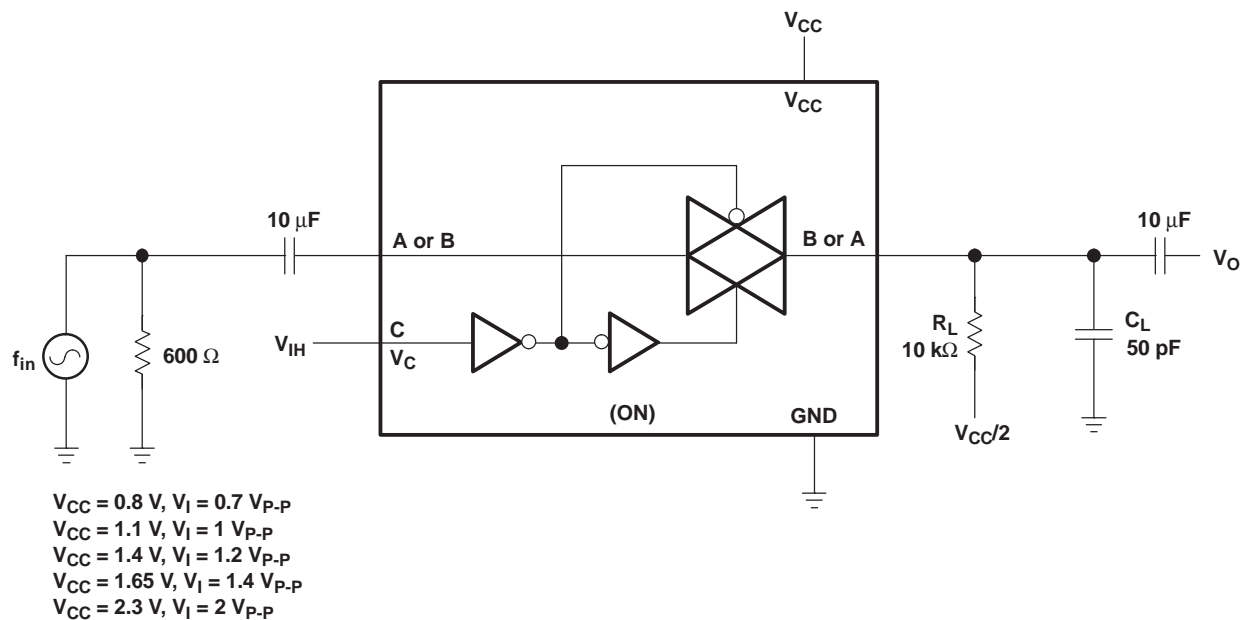

Figure 10. Sine-Wave Distortion

PACKAGING INFORMATION

Orderable Device	Status (1)	Package Type	Package Drawing	Pins	Package Qty	Eco Plan (2)	Lead finish/ Ball material (6)	MSL Peak Temp (3)	Op Temp (°C)	Device Marking (4/5)	Samples
SN74AUC2G66DCTR	ACTIVE	SM8	DCT	8	3000	RoHS & Green	NIPDAU	Level-1-260C-UNLIM	-40 to 85	U66 (R, Z)	Samples
SN74AUC2G66DCUR	ACTIVE	VSSOP	DCU	8	3000	RoHS & Green	NIPDAU SN	Level-1-260C-UNLIM	-40 to 85	(66, U66Q, U66R) (UR, UZ)	Samples
SN74AUC2G66DCURG4	ACTIVE	VSSOP	DCU	8	3000	RoHS & Green	NIPDAU	Level-1-260C-UNLIM	-40 to 85	U66R	Samples
SN74AUC2G66YZPR	ACTIVE	DSBGA	YZP	8	3000	RoHS & Green	SNAGCU	Level-1-260C-UNLIM	-40 to 85	U6N	Samples

(1) The marketing status values are defined as follows:

ACTIVE: Product device recommended for new designs.

LIFEBUY: TI has announced that the device will be discontinued, and a lifetime-buy period is in effect.

NRND: Not recommended for new designs. Device is in production to support existing customers, but TI does not recommend using this part in a new design.

PREVIEW: Device has been announced but is not in production. Samples may or may not be available.

OBSOLETE: TI has discontinued the production of the device.

(2) **RoHS:** TI defines "RoHS" to mean semiconductor products that are compliant with the current EU RoHS requirements for all 10 RoHS substances, including the requirement that RoHS substance do not exceed 0.1% by weight in homogeneous materials. Where designed to be soldered at high temperatures, "RoHS" products are suitable for use in specified lead-free processes. TI may reference these types of products as "Pb-Free".

RoHS Exempt: TI defines "RoHS Exempt" to mean products that contain lead but are compliant with EU RoHS pursuant to a specific EU RoHS exemption.

Green: TI defines "Green" to mean the content of Chlorine (Cl) and Bromine (Br) based flame retardants meet JS709B low halogen requirements of <=1000ppm threshold. Antimony trioxide based flame retardants must also meet the <=1000ppm threshold requirement.

(3) MSL, Peak Temp. - The Moisture Sensitivity Level rating according to the JEDEC industry standard classifications, and peak solder temperature.

(4) There may be additional marking, which relates to the logo, the lot trace code information, or the environmental category on the device.

(5) Multiple Device Markings will be inside parentheses. Only one Device Marking contained in parentheses and separated by a "~" will appear on a device. If a line is indented then it is a continuation of the previous line and the two combined represent the entire Device Marking for that device.

(6) Lead finish/Ball material - Orderable Devices may have multiple material finish options. Finish options are separated by a vertical ruled line. Lead finish/Ball material values may wrap to two lines if the finish value exceeds the maximum column width.

Important Information and Disclaimer: The information provided on this page represents TI's knowledge and belief as of the date that it is provided. TI bases its knowledge and belief on information provided by third parties, and makes no representation or warranty as to the accuracy of such information. Efforts are underway to better integrate information from third parties. TI has taken and

continues to take reasonable steps to provide representative and accurate information but may not have conducted destructive testing or chemical analysis on incoming materials and chemicals. TI and TI suppliers consider certain information to be proprietary, and thus CAS numbers and other limited information may not be available for release.

In no event shall TI's liability arising out of such information exceed the total purchase price of the TI part(s) at issue in this document sold by TI to Customer on an annual basis.

TAPE AND REEL INFORMATION

QUADRANT ASSIGNMENTS FOR PIN 1 ORIENTATION IN TAPE

*All dimensions are nominal

Device	Package Type	Package Drawing	Pins	SPQ	Reel Diameter (mm)	Reel Width W1 (mm)	A0 (mm)	B0 (mm)	K0 (mm)	P1 (mm)	W (mm)	Pin1 Quadrant
SN74AUC2G66DCTR	SM8	DCT	8	3000	180.0	13.0	3.35	4.5	1.55	4.0	12.0	Q3
SN74AUC2G66DCTR	SM8	DCT	8	3000	177.8	12.4	3.45	4.4	1.45	4.0	12.0	Q3
SN74AUC2G66DCUR	VSSOP	DCU	8	3000	180.0	8.4	2.25	3.35	1.05	4.0	8.0	Q3
SN74AUC2G66DCUR	VSSOP	DCU	8	3000	180.0	9.0	2.25	3.4	1.0	4.0	8.0	Q3
SN74AUC2G66DCURG4	VSSOP	DCU	8	3000	180.0	8.4	2.25	3.35	1.05	4.0	8.0	Q3
SN74AUC2G66YZPR	DSBGA	YZP	8	3000	178.0	9.2	1.02	2.02	0.63	4.0	8.0	Q1

TAPE AND REEL BOX DIMENSIONS

*All dimensions are nominal

Device	Package Type	Package Drawing	Pins	SPQ	Length (mm)	Width (mm)	Height (mm)
SN74AUC2G66DCTR	SM8	DCT	8	3000	182.0	182.0	20.0
SN74AUC2G66DCTR	SM8	DCT	8	3000	183.0	183.0	20.0
SN74AUC2G66DCUR	VSSOP	DCU	8	3000	202.0	201.0	28.0
SN74AUC2G66DCUR	VSSOP	DCU	8	3000	182.0	182.0	20.0
SN74AUC2G66DCURG4	VSSOP	DCU	8	3000	202.0	201.0	28.0
SN74AUC2G66YZPR	DSBGA	YZP	8	3000	220.0	220.0	35.0



4225266/A 09/2014

NOTES:

1. All linear dimensions are in millimeters. Any dimensions in parenthesis are for reference only. Dimensioning and tolerancing per ASME Y14.5M.
2. This drawing is subject to change without notice.
3. This dimension does not include mold flash, protrusions, or gate burrs. Mold flash, protrusions, or gate burrs shall not exceed 0.15 mm per side.
4. Reference JEDEC registration MO-187 variation CA.

EXAMPLE BOARD LAYOUT

DCU0008A

VSSOP - 0.9 mm max height

SMALL OUTLINE PACKAGE

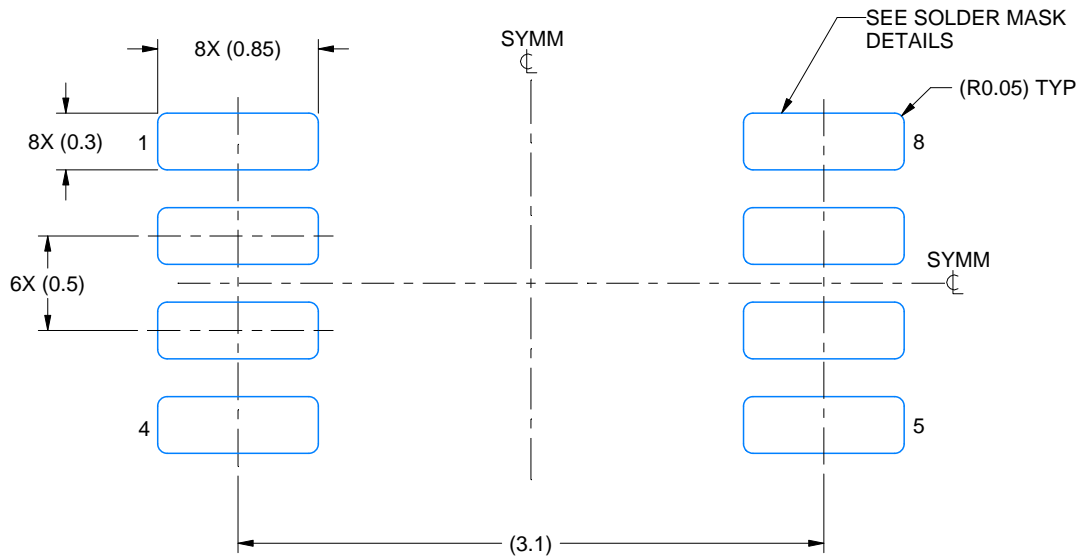

LAND PATTERN EXAMPLE
EXPOSED METAL SHOWN
SCALE: 25X



4225266/A 09/2014

NOTES: (continued)

5. Publication IPC-7351 may have alternate designs.
6. Solder mask tolerances between and around signal pads can vary based on board fabrication site.

EXAMPLE STENCIL DESIGN

DCU0008A

VSSOP - 0.9 mm max height

SMALL OUTLINE PACKAGE



SOLDER PASTE EXAMPLE
BASED ON 0.125 mm THICK STENCIL
SCALE: 25X

4225266/A 09/2014

NOTES: (continued)

7. Laser cutting apertures with trapezoidal walls and rounded corners may offer better paste release. IPC-7525 may have alternate design recommendations.
8. Board assembly site may have different recommendations for stencil design.

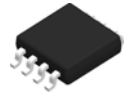

4220784/C 06/2021

NOTES:

1. All linear dimensions are in millimeters. Dimensions in parenthesis are for reference only. Dimensioning and tolerancing per ASME Y14.5M.
2. This drawing is subject to change without notice.
3. This dimension does not include mold flash, protrusions, or gate burrs. Mold flash, protrusions, or gate burrs shall not exceed 0.15 mm per side.
4. This dimension does not include interlead flash. Interlead flash shall not exceed 0.25 mm per side.

EXAMPLE BOARD LAYOUT

DCT0008A

SSOP - 1.3 mm max height

SMALL OUTLINE PACKAGE

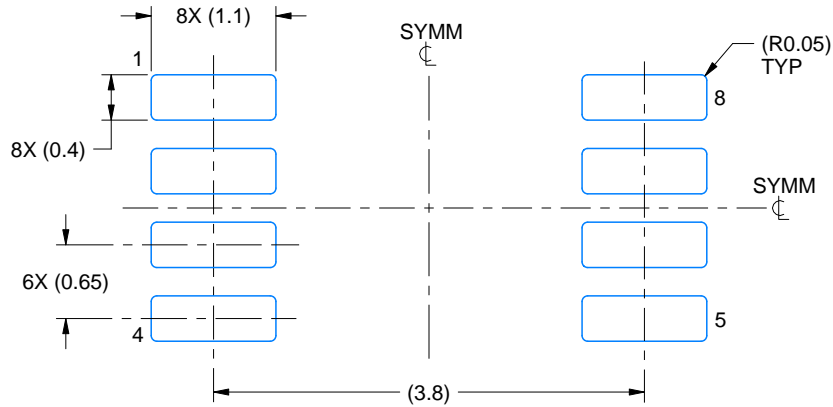

LAND PATTERN EXAMPLE
EXPOSED METAL SHOWN
SCALE:15X

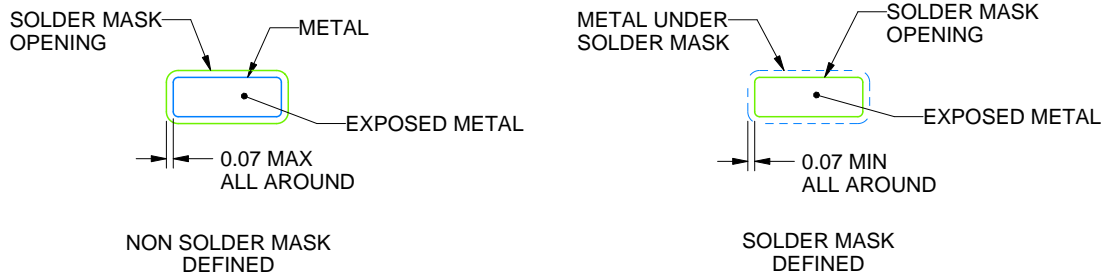

SOLDER MASK DETAILS

4220784/C 06/2021

NOTES: (continued)

- 5. Publication IPC-7351 may have alternate designs.
- 6. Solder mask tolerances between and around signal pads can vary based on board fabrication site.

EXAMPLE STENCIL DESIGN

DCT0008A

SSOP - 1.3 mm max height

SMALL OUTLINE PACKAGE

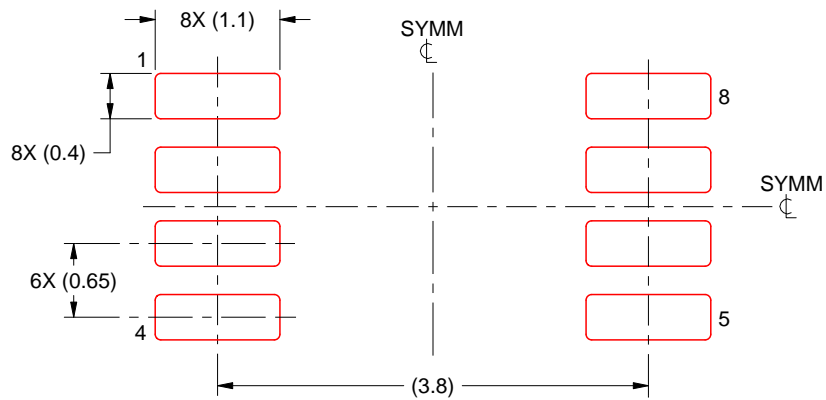

SOLDER PASTE EXAMPLE
BASED ON 0.125 mm THICK STENCIL
SCALE:15X

4220784/C 06/2021

NOTES: (continued)

7. Laser cutting apertures with trapezoidal walls and rounded corners may offer better paste release. IPC-7525 may have alternate design recommendations.
8. Board assembly site may have different recommendations for stencil design.

YZP0008



PACKAGE OUTLINE

DSBGA - 0.5 mm max height

DIE SIZE BALL GRID ARRAY

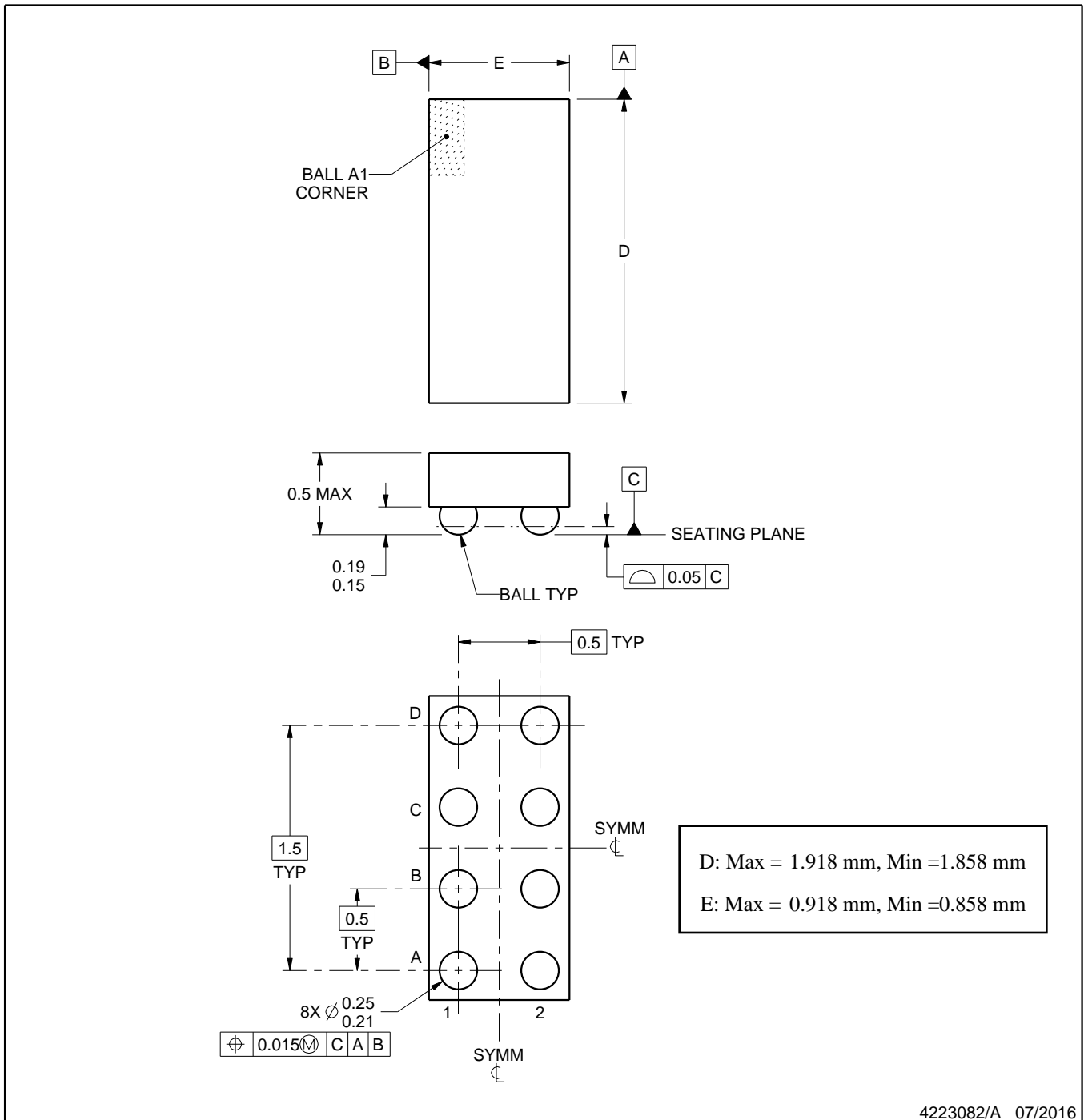

4223082/A 07/2016

NOTES:

1. All linear dimensions are in millimeters. Any dimensions in parenthesis are for reference only. Dimensioning and tolerancing per ASME Y14.5M.
2. This drawing is subject to change without notice.

EXAMPLE BOARD LAYOUT

YZP0008

DSBGA - 0.5 mm max height

DIE SIZE BALL GRID ARRAY



LAND PATTERN EXAMPLE
SCALE:40X



SOLDER MASK DETAILS
NOT TO SCALE

4223082/A 07/2016

NOTES: (continued)

3. Final dimensions may vary due to manufacturing tolerance considerations and also routing constraints. For more information, see Texas Instruments literature number SNVA009 (www.ti.com/lit/snva009).

EXAMPLE STENCIL DESIGN

YZP0008

DSBGA - 0.5 mm max height

DIE SIZE BALL GRID ARRAY

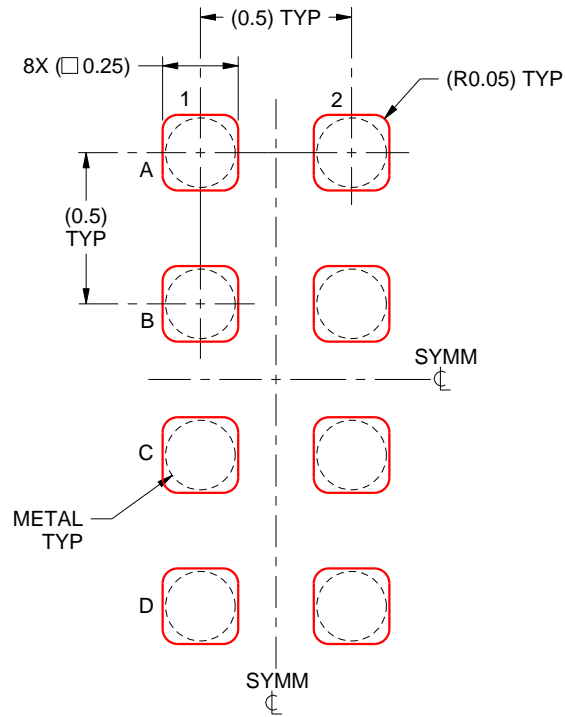

SOLDER PASTE EXAMPLE
BASED ON 0.1 mm THICK STENCIL
SCALE:40X

4223082/A 07/2016

NOTES: (continued)

4. Laser cutting apertures with trapezoidal walls and rounded corners may offer better paste release.

IMPORTANT NOTICE AND DISCLAIMER

TI PROVIDES TECHNICAL AND RELIABILITY DATA (INCLUDING DATA SHEETS), DESIGN RESOURCES (INCLUDING REFERENCE DESIGNS), APPLICATION OR OTHER DESIGN ADVICE, WEB TOOLS, SAFETY INFORMATION, AND OTHER RESOURCES "AS IS" AND WITH ALL FAULTS, AND DISCLAIMS ALL WARRANTIES, EXPRESS AND IMPLIED, INCLUDING WITHOUT LIMITATION ANY IMPLIED WARRANTIES OF MERCHANTABILITY, FITNESS FOR A PARTICULAR PURPOSE OR NON-INFRINGEMENT OF THIRD PARTY INTELLECTUAL PROPERTY RIGHTS.

These resources are intended for skilled developers designing with TI products. You are solely responsible for (1) selecting the appropriate TI products for your application, (2) designing, validating and testing your application, and (3) ensuring your application meets applicable standards, and any other safety, security, regulatory or other requirements.

These resources are subject to change without notice. TI grants you permission to use these resources only for development of an application that uses the TI products described in the resource. Other reproduction and display of these resources is prohibited. No license is granted to any other TI intellectual property right or to any third party intellectual property right. TI disclaims responsibility for, and you will fully indemnify TI and its representatives against, any claims, damages, costs, losses, and liabilities arising out of your use of these resources.

TI's products are provided subject to [TI's Terms of Sale](#) or other applicable terms available either on [ti.com](https://www.ti.com) or provided in conjunction with such TI products. TI's provision of these resources does not expand or otherwise alter TI's applicable warranties or warranty disclaimers for TI products.

TI objects to and rejects any additional or different terms you may have proposed.

Mailing Address: Texas Instruments, Post Office Box 655303, Dallas, Texas 75265
Copyright © 2023, Texas Instruments Incorporated

X-ON Electronics

Largest Supplier of Electrical and Electronic Components

Click to view similar products for [Analogue Switch ICs](#) category:

Click to view products by [Texas Instruments](#) manufacturer:

Other Similar products are found below :

[FSA3051TMX](#) [NLAS5223BLMNR2G](#) [NLX2G66DMUTCG](#) [TC74HC4066AFTEL](#) [425541DB](#) [DG403DY](#) [099044FB](#) [MAX4762ETB+](#)
[NLAS3799BMNR2G](#) [NLAS5123MNR2G](#) [ISL84684IR](#) [PI5A4157CEX](#) [PI5A4599BCEX](#) [NLAS4717EPFCT1G](#) [PI5A3167CCEX](#)
[SLAS3158MNR2G](#) [PI5A392AQE](#) [ADG714BCPZ-REEL7](#) [DG333ALDW-T1-E3](#) [ISL43113IB](#) [ISL43140IB](#) [ISL43140IBZ-T](#) [ISL43143IR](#)
[ISL43L120IR](#) [ISL43L121IR](#) [ISL43L122IR](#) [ISL43L220IR](#) [ISL43L410IR](#) [ISL43L420IR](#) [ISL43L710IR](#) [ISL43L711IR](#) [ISL43L712IR](#)
[ISL84053IA](#) [ISL84514IB](#) [ISL84516IB](#) [ISL84684IUZ-T](#) [LNLASB3157DFT2G](#) [NLAS324US](#) [NLASTV4599DFT2G](#) [TPW4053-SR](#)
[WAS4642Q-24/TR](#) [ADG842YKSZ-REEL7](#) [WAS4766C-9/TR](#) [WAS7227Q-10/TR](#) [WAS4646C-36/TR](#) [WAS4735Q-16/TR](#) [BL1532TQFN](#)
[RS2233YS16](#) [CH483M](#) [TMUX1248DCKR](#)