

## SN74AXC2T45 具有可配置电平转换的 2 位转换收发器

### 1 特性

- 完全可配置的双轨设计可允许各个端口在 0.65V 至 3.6V 的电源电压范围内运行
- 工作温度范围为 -40°C 至 +125°C
- 无干扰电源时序
- 从 1.8V 转换到 3.3V 时，支持高达 380Mbps 的转换速率
- $V_{CC}$  隔离特性
  - 如果任何一个  $V_{CC}$  输入低于 100mV，则所有 I/O 输出均禁用且处于高阻抗状态
- $I_{off}$  支持局部断电模式运行
- 兼容 AVC 系列电平转换器
- 闩锁性能超过 100mA，符合 JESD 78 II 类规范
- ESD 保护性能超过 JESD 22 规范要求
  - 8000V 人体放电模型
  - 1000V 充电器件模型

### 2 应用

- 企业与通信
- 工业
- 个人电子产品
- 无线基础设施
- 楼宇自动化
- 销售终端

### 3 描述

SN74AXC2T45 是一款使用两个独立可配置电源轨的 2 位同相总线收发器。 $V_{CCA}$  和  $V_{CCB}$  电源电压低至 0.65V 时，该器件可正常工作。A 端口用于跟踪  $V_{CCA}$ ，该端口可支持 0.65V 至 3.6V 范围内的任何电源电压。B 端口用于跟踪  $V_{CCB}$ ，该端口也可支持 0.65V 至 3.6V 范围内的任何电源电压。此外，SN74AXC2T45 还与单电源系统兼容。

SN74AXC2T45 器件旨在实现数据总线间的异步通信。根据方向控制输入 (DIR) 上的逻辑电平，该器件将数据从 A 总线传输至 B 总线，或者将数据从 B 总线传输至 A 总线。SN74AXC2T45 器件旨在使控制引脚 (DIR) 以  $V_{CCA}$  为基准。

该器件完全符合使用  $I_{off}$  电流的部分断电应用的规范要求。当器件断电时， $I_{off}$  保护电路可确保不从输入、输出或偏置到特定电压的组合 I/O 获取多余电流，也不向其提供多余电流。

$V_{CC}$  隔离特性可确保当  $V_{CCA}$  或  $V_{CCB}$  低于 100mV 时，I/O 端口均禁用其输出并进入高阻抗状态。

无干扰电源时序使电源轨能以任何顺序打开或关断，从而提供强大的电源时序性能。

#### 器件信息(1)

器件型号	封装	封装尺寸 (标称值)
SN74AXC2T45DCT	SM8 (8)	2.95mm × 2.80mm
SN74AXC2T45DCU	超薄小外形尺寸封装 (VSSOP) (8)	2.30mm × 2.00mm
SN74AXC2T45DTM	X2SON (8)	1.35mm × 0.80mm

(1) 如需了解所有可用封装，请参阅数据表末尾的可订购产品附录。

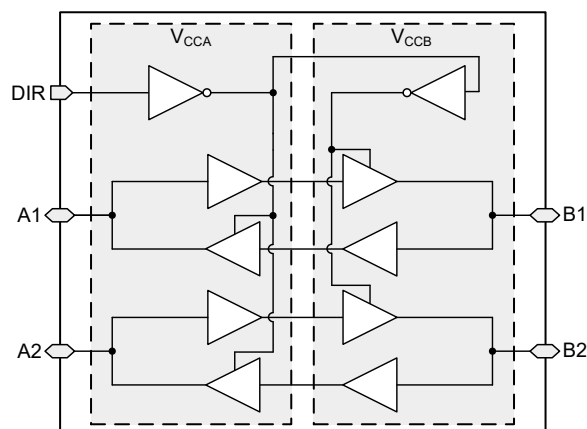

功能方框图



## Table of Contents

<b>1 特性</b> .....	1	7.1 Load Circuit and Voltage Waveforms.....	19
<b>2 应用</b> .....	1	<b>8 Detailed Description</b> .....	21
<b>3 描述</b> .....	1	8.1 Overview.....	21
<b>4 Revision History</b> .....	2	8.2 Functional Block Diagram.....	21
<b>5 Pin Configuration and Functions</b> .....	3	8.3 Feature Description.....	21
<b>6 Specifications</b> .....	4	8.4 Device Functional Modes.....	22
6.1 Absolute Maximum Ratings.....	4	<b>9 Application and Implementation</b> .....	23
6.2 ESD Ratings.....	4	9.1 Application Information.....	23
6.3 Recommended Operating Conditions.....	5	9.2 Typical Application.....	23
6.4 Thermal Information.....	5	<b>10 Power Supply Recommendations</b> .....	25
6.5 Electrical Characteristics.....	7	<b>11 Layout</b> .....	25
6.6 Switching Characteristics, $V_{CCA} = 0.7 \pm 0.05 \text{ V}$ .....	9	11.1 Layout Guidelines.....	25
6.7 Switching Characteristics, $V_{CCA} = 0.8 \pm 0.04 \text{ V}$ .....	10	11.2 Layout Example.....	25
6.8 Switching Characteristics, $V_{CCA} = 0.9 \pm 0.045 \text{ V}$ .....	11	<b>12 Device and Documentation Support</b> .....	26
6.9 Switching Characteristics, $V_{CCA} = 1.2 \pm 0.1 \text{ V}$ .....	12	12.1 Documentation Support.....	26
6.10 Switching Characteristics, $V_{CCA} = 1.5 \pm 0.1 \text{ V}$ .....	13	12.2 接收文档更新通知.....	26
6.11 Switching Characteristics, $V_{CCA} = 1.8 \pm 0.15 \text{ V}$ .....	14	12.3 支持资源.....	26
6.12 Switching Characteristics, $V_{CCA} = 2.5 \pm 0.2 \text{ V}$ .....	15	12.4 Trademarks.....	26
6.13 Switching Characteristics, $V_{CCA} = 3.3 \pm 0.3 \text{ V}$ .....	16	12.5 Electrostatic Discharge Caution.....	26
6.14 Operating Characteristics: $T_A = 25^\circ\text{C}$ .....	17	12.6 Glossary.....	26
6.15 Typical Characteristics.....	18	<b>13 Mechanical, Packaging, and Orderable Information</b> .....	26
<b>7 Parameter Measurement Information</b> .....	19		

## 4 Revision History

注：以前版本的页码可能与当前版本的页码不同

Changes from Revision B (January 2020) to Revision C (June 2021)	Page
• 更新了整个文档中的表格、图和交叉参考的编号格式.....	1
• Updated the <i>Enable Times</i> section.....	23
Changes from Revision A (December 2019) to Revision B (January 2020)	Page
• 向数据表添加了 DCU 和 DCT 封装。.....	1
Changes from Revision * (August 2019) to Revision A (December 2019)	Page
• 将“预告信息”更改为“生产数据”.....	1

## 5 Pin Configuration and Functions



图 5-1. DCT Package 8-Pin SM8 Top View



图 5-2. DCU Package 8-Pin VSSOP Top View

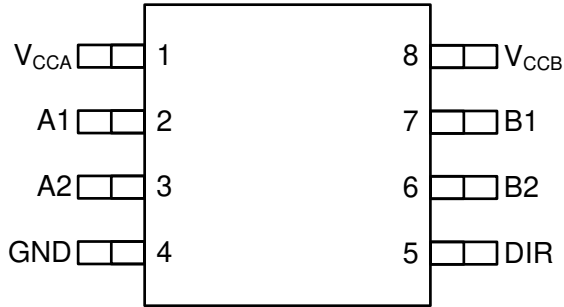

图 5-3. DTM Package 8-Pin X2SON Transparent Top View

表 5-1. Pin Functions

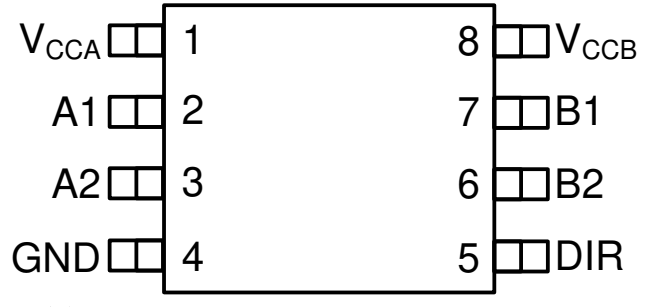
PIN	NO.	DESCRIPTION
NAME	DTM, DCU, DCT	
A1	2	Input/output A1. Referenced to $V_{CCA}$ .
A2	3	Input/output A2. Referenced to $V_{CCA}$ .
B1	7	Input/output B1. Referenced to $V_{CCB}$ .
B2	6	Input/output B2. Referenced to $V_{CCB}$ .
DIR	5	Direction-control in for both ports. Referenced to $V_{CCA}$ .
GND	4	Ground
$V_{CCA}$	1	A-port power supply voltage. $0.65\text{ V} \leq V_{CCA} \leq 3.6\text{ V}$
$V_{CCB}$	8	B-port power supply voltage. $0.65\text{ V} \leq V_{CCB} \leq 3.6\text{ V}$

## 6 Specifications

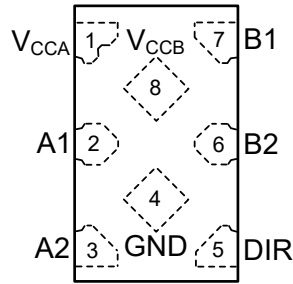
### 6.1 Absolute Maximum Ratings

over operating free-air temperature range (unless otherwise noted)<sup>(1)</sup>

			MIN	MAX	UNITS
V <sub>CCA</sub>	Supply voltage A		- 0.5	4.2	V
V <sub>CCB</sub>	Supply voltage B		- 0.5	4.2	V
V <sub>I</sub>	Input Voltage <sup>(2)</sup>	I/O Ports (A Port)	- 0.5	4.2	V
		I/O Ports (B Port)	- 0.5	4.2	
		Control Inputs	- 0.5	4.2	
V <sub>O</sub>	Voltage applied to any output in the high-impedance or power-off state <sup>(2)</sup>	A Port	- 0.5	4.2	V
		B Port	- 0.5	4.2	
V <sub>O</sub>	Voltage applied to any output in the high or low state <sup>(2) (3)</sup>	A Port	- 0.5 V <sub>CCA</sub> + 0.2		V
		B Port	- 0.5 V <sub>CCB</sub> + 0.2		
I <sub>IK</sub>	Input clamp current	V <sub>I</sub> < 0	- 50		mA
I <sub>OK</sub>	Output clamp current	V <sub>O</sub> < 0	- 50		mA
I <sub>O</sub>	Continuous output current		- 50	50	mA
	Continuous current through V <sub>CC</sub> or GND		- 100	100	
T <sub>J</sub>	Junction Temperature			150	°C
T <sub>stg</sub>	Storage temperature		- 65	150	°C

- (1) Stresses beyond those listed under *Absolute Maximum Ratings* may cause permanent damage to the device. These are stress ratings only, which do not imply functional operation of the device at these or any other conditions beyond those indicated under *Recommended Operating Conditions*. Exposure to absolute-maximum-rated conditions for extended periods may affect device reliability.
- (2) The input voltage and output negative-voltage ratings may be exceeded if the input and output current ratings are observed.
- (3) The output positive-voltage rating may be exceeded up to 4.2 V maximum if the output current rating is observed.

### 6.2 ESD Ratings

			VALUE	UNIT
V <sub>(ESD)</sub>	Electrostatic discharge	Human body model (HBM), per ANSI/ESDA/JEDEC JS-001 <sup>(1)</sup>	±8000	V
		Charged device model (CDM), per JEDEC Specification JESD22-C101 <sup>(2)</sup>	±1000	

- (1) JEDEC document JEP155 states that 500-V HBM allows safe manufacturing with a standard ESD control process.
- (2) JEDEC document JEP157 states that 250-V CDM allows safe manufacturing with a standard ESD control process.

### 6.3 Recommended Operating Conditions

over operating free-air temperature range (unless otherwise noted)<sup>(1) (2)</sup>

			MIN	MAX	UNIT
V <sub>CCA</sub>	Supply voltage A		0.65	3.6	V
V <sub>CCB</sub>	Supply voltage B		0.65	3.6	V
V <sub>IH</sub>	High-level input voltage	Data Inputs	V <sub>CCI</sub> = 0.65 V - 0.75 V	V <sub>CCI</sub> × 0.70	V
			V <sub>CCI</sub> = 0.76 V - 1 V	V <sub>CCI</sub> × 0.70	
			V <sub>CCI</sub> = 1.1 V - 1.95 V	V <sub>CCI</sub> × 0.65	
			V <sub>CCI</sub> = 2.3 V - 2.7 V	1.6	
			V <sub>CCI</sub> = 3 V - 3.6 V	2	
		Control Input (DIR), Referenced to V <sub>CCA</sub>	V <sub>CCA</sub> = 0.65 V - 0.75 V	V <sub>CCA</sub> × 0.70	
			V <sub>CCA</sub> = 0.76 V - 1 V	V <sub>CCA</sub> × 0.70	
			V <sub>CCA</sub> = 1.1 V - 1.95 V	V <sub>CCA</sub> × 0.65	
			V <sub>CCA</sub> = 2.3 V - 2.7 V	1.6	
			V <sub>CCA</sub> = 3 V - 3.6 V	2	
V <sub>IL</sub>	Low-level input voltage	Data Inputs	V <sub>CCI</sub> = 0.65 V - 0.75 V	V <sub>CCI</sub> × 0.30	V
			V <sub>CCI</sub> = 0.76 V - 1 V	V <sub>CCI</sub> × 0.30	
			V <sub>CCI</sub> = 1.1 V - 1.95 V	V <sub>CCI</sub> × 0.35	
			V <sub>CCI</sub> = 2.3 V - 2.7 V	0.7	
			V <sub>CCI</sub> = 3 V - 3.6 V	0.8	
		Control Input (DIR), Referenced to V <sub>CCA</sub>	V <sub>CCA</sub> = 0.65 V - 0.75 V	V <sub>CCA</sub> × 0.30	
			V <sub>CCA</sub> = 0.76 V - 1 V	V <sub>CCA</sub> × 0.30	
			V <sub>CCA</sub> = 1.1 V - 1.95 V	V <sub>CCA</sub> × 0.35	
			V <sub>CCA</sub> = 2.3 V - 2.7 V	0.7	
			V <sub>CCA</sub> = 3 V - 3.6 V	0.8	
V <sub>I</sub>	Input voltage		0	3.6	V
V <sub>O</sub>	Output voltage	Active State	0	V <sub>CCO</sub>	V
		Tri-State	0	3.6	
$\frac{\Delta t}{\Delta v^{(2)}}$	Input transition rise and fall time			10	ns/V
$\frac{\Delta t}{\Delta v^{(3)}}$	Single channel input transition rise and fall time			100	ns/V
T <sub>A</sub>	Operating free-air temperature		- 40	125	°C

- (1) V<sub>CCI</sub> is the V<sub>CC</sub> associated with the input port. V<sub>CCO</sub> is the V<sub>CC</sub> associated with the output port.
- (2) All unused inputs of the device must be held at V<sub>CC</sub> or GND to ensure proper device operation. Refer to the TI application report, [Implications of Slow or Floating CMOS Inputs](#), SCBA004.
- (3) Input transition rate of a single channel while the other channels are at a valid logic state and not switching.

### 6.4 Thermal Information

THERMAL METRIC <sup>(1)</sup>		SN74AXC2T45			UNIT
		DCT (SM8)	DCU (VSSOP)	DTM (X2SON)	
R <sub>θJA</sub>	Junction-to-ambient thermal resistance	223.5	242.9	225.9	°C/W
R <sub>θJC(top)</sub>	Junction-to-case (top) thermal resistance	120.7	96.2	131.6	°C/W
R <sub>θJB</sub>	Junction-to-board thermal resistance	138.0	153.3	141.3	°C/W
Y <sub>JT</sub>	Junction-to-top characterization parameter	47.5	38.2	12.7	°C/W

## 6.4 Thermal Information (continued)

THERMAL METRIC <sup>(1)</sup>		SN74AXC2T45			UNIT
		DCT (SM8)	DCU (VSSOP)	DTM (X2SON)	
Y <sub>JB</sub>	Junction-to-board characterization parameter	136.7	152.5	140.9	°C/W

(1) For more information about thermal metrics, see the [Semiconductor and IC Package Thermal Metrics](#) application report.

## 6.5 Electrical Characteristics

over operating free-air temperature range (unless otherwise noted) (1) (2) (3)

PARAMETER	TEST CONDITIONS	$V_{CCA}$	$V_{CCB}$	Operating free-air temperature ( $T_A$ )						UNIT		
				-40°C to 85°C			-40°C to 125°C					
				MIN	TYP	MAX	MIN	TYP	MAX			
$V_{OH}$	High-level output voltage	$V_I = V_{IH}$	$I_{OH} = -100 \mu A$	0.7 V - 3.6 V	0.7 V - 3.6 V	$V_{CCO} - 0.1$			$V_{CCO} - 0.1$		V	
			$I_{OH} = -50 \mu A$	0.65 V	0.65 V	0.55			0.55			
			$I_{OH} = -200 \mu A$	0.76 V	0.76 V	0.58			0.58			
			$I_{OH} = -500 \mu A$	0.85 V	0.85 V	0.65			0.65			
			$I_{OH} = -3 \text{ mA}$	1.1 V	1.1 V	0.85			0.85			
			$I_{OH} = -6 \text{ mA}$	1.4 V	1.4 V	1.05			1.05			
			$I_{OH} = -8 \text{ mA}$	1.65 V	1.65 V	1.2			1.2			
			$I_{OH} = -9 \text{ mA}$	2.3 V	2.3 V	1.75			1.75			
			$I_{OH} = -12 \text{ mA}$	3 V	3 V	2.3			2.3			
$V_{OL}$	Low-level output voltage	$V_I = V_{IL}$	$I_{OL} = 100 \mu A$	0.7 V - 3.6 V	0.7 V - 3.6 V			0.1		0.1	V	
			$I_{OL} = 50 \mu A$	0.65 V	0.65 V			0.1		0.1		
			$I_{OL} = 200 \mu A$	0.76 V	0.76 V			0.18		0.18		
			$I_{OL} = 500 \mu A$	0.85 V	0.85 V			0.2		0.2		
			$I_{OL} = 3 \text{ mA}$	1.1 V	1.1 V			0.25		0.25		
			$I_{OL} = 6 \text{ mA}$	1.4 V	1.4 V			0.35		0.35		
			$I_{OL} = 8 \text{ mA}$	1.65 V	1.65 V			0.45		0.45		
			$I_{OL} = 9 \text{ mA}$	2.3 V	2.3 V			0.55		0.55		
			$I_{OL} = 12 \text{ mA}$	3 V	3 V			0.7		0.7		
$I_I$	Input leakage current	Control input (DIR): $V_I = V_{CCI}$ or GND		0.65 V - 3.6 V	0.65 V - 3.6 V	-0.5		0.5	-1		1	$\mu A$
		Data Inputs (Ax, Bx), $V_I = V_{CCI}$ or GND		0.65 V - 3.6 V	0.65 V - 3.6 V	-4		4	-8		8	$\mu A$
$I_{off}$	Partial power down current	A Port: $V_I$ or $V_O = 0 \text{ V} - 3.6 \text{ V}$		0 V	0 V - 3.6 V	-4		4	-8		8	$\mu A$
		B Port: $V_I$ or $V_O = 0 \text{ V} - 3.6 \text{ V}$		0 V - 3.6 V	0 V	-4		4	-8		8	$\mu A$
$I_{CCA}$	$V_{CCA}$ supply current	$V_I = V_{CCI}$ or GND	$I_O = 0$	0.65 V - 3.6 V	0.65 V - 3.6 V			8			14	$\mu A$
				0 V	3.6 V	-2			-12			
				3.6 V	0 V			4		8		
$I_{CCB}$	$V_{CCB}$ supply current	$V_I = V_{CCI}$ or GND	$I_O = 0$	0.65 V - 3.6 V	0.65 V - 3.6 V			8			14	$\mu A$
				0 V	3.6 V			4		8		
				3.6 V	0 V	-2			-12			
$I_{CCA} + I_{CCB}$	Combined supply current	$V_I = V_{CCI}$ or GND	$I_O = 0$	0.65 V - 3.6 V	0.65 V - 3.6 V			16			23	$\mu A$
$C_i$	Control Input (DIR) Capacitance	$V_I = 3.3 \text{ V}$ or GND		3.3 V	3.3 V			3.3			3.3	pF
$C_{io}$	Data I/O Capacitance	$V_O = 1.65 \text{ V DC} + 1 \text{ MHz} - 16 \text{ dBm}$ sine wave		3.3 V	3.3 V			5.4			5.4	pF

(1)  $V_{CCI}$  is the  $V_{CC}$  associated with the input port.

(2)  $V_{CCO}$  is the  $V_{CC}$  associated with the output port.

(3) All typical data is taken at 25°C.



## 6.6 Switching Characteristics, $V_{CCA} = 0.7 \pm 0.05 \text{ V}$

See [Figure 5](#) and [Table 1](#) for test circuit and loading. See [Figure 6](#), [Figure 7](#), and [Figure 8](#) for measurement waveforms.

PARAMETER	FROM	TO	Test Conditions	B-Port Supply Voltage ( $V_{CCB}$ )														UNIT			
				$0.7 \pm 0.05 \text{ V}$		$0.8 \pm 0.04 \text{ V}$		$0.9 \pm 0.045 \text{ V}$		$1.2 \pm 0.1 \text{ V}$		$1.5 \pm 0.1 \text{ V}$		$1.8 \pm 0.15 \text{ V}$		$2.5 \pm 0.2 \text{ V}$			$3.3 \pm 0.3 \text{ V}$		
				MIN	MAX	MIN	MAX	MIN	MAX	MIN	MAX	MIN	MAX	MIN	MAX	MIN	MAX		MIN	MAX	
$t_{pd}$	Propagation delay	A	B	-40°C to 85°C	0.5	170	0.5	115	0.5	84	0.5	50	0.5	50	0.5	56	0.5	71	0.5	106	ns
				-40°C to 125°C	0.5	170	0.5	115	0.5	84	0.5	50	0.5	50	0.5	56	0.5	71	0.5	106	
	B	A	-40°C to 85°C	0.5	170	0.5	149	0.5	122	0.5	83	0.5	79	0.5	78	0.5	77	0.5	76		
			-40°C to 125°C	0.5	170	0.5	149	0.5	122	0.5	83	0.5	79	0.5	78	0.5	77	0.5	76		
$t_{dis}$	Disable time	DIR	A	-40°C to 85°C	0.5	140	0.5	140	0.5	140	0.5	140	0.5	140	0.5	140	0.5	140	0.5	140	ns
				-40°C to 125°C	0.5	140	0.5	140	0.5	140	0.5	140	0.5	140	0.5	140	0.5	140	0.5	140	
	DIR	B	-40°C to 85°C	0.5	143	0.5	105	0.5	84	0.5	41	0.5	39	0.5	42	0.5	56	0.5	107		
			-40°C to 125°C	0.5	143	0.5	105	0.5	84	0.5	41	0.5	39	0.5	42	0.5	56	0.5	107		
$t_{en}$	Enable time	DIR	A	-40°C to 85°C	0.5	311	0.5	311	0.5	311	0.5	311	0.5	311	0.5	311	0.5	311	0.5	311	ns
				-40°C to 125°C	0.5	311	0.5	311	0.5	311	0.5	311	0.5	311	0.5	311	0.5	311	0.5	311	
	DIR	B	-40°C to 85°C	0.5	306	0.5	247	0.5	216	0.5	186	0.5	182	0.5	183	0.5	194	0.5	228		
			-40°C to 125°C	0.5	306	0.5	247	0.5	216	0.5	186	0.5	182	0.5	183	0.5	194	0.5	228		

## 6.7 Switching Characteristics, $V_{CCA} = 0.8 \pm 0.04 \text{ V}$

See Figure 5 and Table 1 for test circuit and loading. See Figure 6, Figure 7, and Figure 8 for measurement waveforms.

PARAMETER	FROM	TO	Test Conditions	B-Port Supply Voltage ( $V_{CCB}$ )														UNIT			
				0.7 ± 0.05 V		0.8 ± 0.04 V		0.9 ± 0.045 V		1.2 ± 0.1 V		1.5 ± 0.1 V		1.8 ± 0.15 V		2.5 ± 0.2 V			3.3 ± 0.3 V		
				MIN	MAX	MIN	MAX	MIN	MAX	MIN	MAX	MIN	MAX	MIN	MAX	MIN	MAX		MIN	MAX	
$t_{pd}$	Propagation delay	A	B	-40°C to 85°C	0.5	150	0.5	94	0.5	63	0.5	33	0.5	28	0.5	27	0.5	28	0.5	34	ns
				-40°C to 125°C	0.5	150	0.5	94	0.5	63	0.5	33	0.5	28	0.5	27	0.5	28	0.5	34	
	B	A	-40°C to 85°C	0.5	115	0.5	94	0.5	76	0.5	50	0.5	41	0.5	40	0.5	38	0.5	38		
			-40°C to 125°C	0.5	115	0.5	94	0.5	76	0.5	50	0.5	41	0.5	40	0.5	38	0.5	38		
$t_{dis}$	Disable time	DIR	A	-40°C to 85°C	0.5	96	0.5	96	0.5	96	0.5	96	0.5	96	0.5	96	0.5	96	0.5	96	ns
				-40°C to 125°C	0.5	96	0.5	96	0.5	96	0.5	96	0.5	96	0.5	96	0.5	96	0.5	96	
	DIR	B	-40°C to 85°C	0.5	136	0.5	97	0.5	76	0.5	33	0.5	27	0.5	26	0.5	28	0.5	35		
			-40°C to 125°C	0.5	136	0.5	97	0.5	76	0.5	33	0.5	27	0.5	26	0.5	28	0.5	35		
$t_{en}^{(1)}$	Enable time	DIR	A	-40°C to 85°C	0.5	246	0.5	246	0.5	246	0.5	246	0.5	246	0.5	246	0.5	246	0.5	246	ns
				-40°C to 125°C	0.5	246	0.5	246	0.5	246	0.5	246	0.5	246	0.5	246	0.5	246	0.5	246	
	DIR	B	-40°C to 85°C	0.5	243	0.5	188	0.5	157	0.5	128	0.5	123	0.5	122	0.5	123	0.5	125		
			-40°C to 125°C	0.5	243	0.5	188	0.5	157	0.5	128	0.5	123	0.5	122	0.5	123	0.5	125		

(1) The enable time is a calculated value, derived using the formula shown in the Enable Times section.

## 6.8 Switching Characteristics, $V_{CCA} = 0.9 \pm 0.045 \text{ V}$

See Figure 5 and Table 1 for test circuit and loading. See Figure 6, Figure 7, and Figure 8 for measurement waveforms.

PARAMETER	FROM	TO	Test Conditions	B-Port Supply Voltage ( $V_{CCB}$ )																UNIT	
				0.7 ± 0.05 V		0.8 ± 0.04 V		0.9 ± 0.045 V		1.2 ± 0.1 V		1.5 ± 0.1 V		1.8 ± 0.15 V		2.5 ± 0.2 V		3.3 ± 0.3 V			
				MIN	MAX	MIN	MAX	MIN	MAX	MIN	MAX	MIN	MAX	MIN	MAX	MIN	MAX	MIN	MAX		
$t_{pd}$	Propagation delay	A	B	-40°C to 85°C	0.5	122	0.5	76	0.5	51	0.5	23	0.5	18	0.5	16	0.5	15	0.5	17	ns
				-40°C to 125°C	0.5	122	0.5	76	0.5	51	0.5	23	0.5	18	0.5	16	0.5	15	0.5	17	
		B	A	-40°C to 85°C	0.5	84	0.5	63	0.5	51	0.5	39	0.5	28	0.5	24	0.5	21	0.5	21	
				-40°C to 125°C	0.5	84	0.5	63	0.5	51	0.5	39	0.5	28	0.5	24	0.5	21	0.5	21	
$t_{dis}$	Disable time	DIR	A	-40°C to 85°C	0.5	74	0.5	74	0.5	74	0.5	74	0.5	74	0.5	74	0.5	74	0.5	74	ns
				-40°C to 125°C	0.5	74	0.5	74	0.5	74	0.5	74	0.5	74	0.5	74	0.5	74	0.5	74	
		DIR	B	-40°C to 85°C	0.5	133	0.5	94	0.5	73	0.5	30	0.5	23	0.5	22	0.5	20	0.5	22	
				-40°C to 125°C	0.5	133	0.5	94	0.5	73	0.5	31	0.5	24	0.5	22	0.5	20	0.5	20	
$t_{en}^{(1)}$	Enable time	DIR	A	-40°C to 85°C	0.5	211	0.5	211	0.5	211	0.5	211	0.5	211	0.5	211	0.5	211	0.5	211	ns
				-40°C to 125°C	0.5	211	0.5	211	0.5	211	0.5	211	0.5	211	0.5	211	0.5	211	0.5	211	
		DIR	B	-40°C to 85°C	0.5	192	0.5	146	0.5	120	0.5	93	0.5	88	0.5	86	0.5	85	0.5	87	
				-40°C to 125°C	0.5	192	0.5	146	0.5	120	0.5	93	0.5	88	0.5	86	0.5	85	0.5	87	

(1) The enable time is a calculated value, derived using the formula shown in the Enable Times section.

## 6.9 Switching Characteristics, $V_{CCA} = 1.2 \pm 0.1 \text{ V}$

See Figure 5 and Table 1 for test circuit and loading. See Figure 6, Figure 7, and Figure 8 for measurement waveforms.

PARAMETER		FROM	TO	Test Conditions	B-Port Supply Voltage ( $V_{CCB}$ )														UNIT			
					0.7 ± 0.05 V		0.8 ± 0.04 V		0.9 ± 0.045 V		1.2 ± 0.1 V		1.5 ± 0.1 V		1.8 ± 0.15 V		2.5 ± 0.2 V			3.3 ± 0.3 V		
					MIN	MAX	MIN	MAX	MIN	MAX	MIN	MAX	MIN	MAX	MIN	MAX	MIN	MAX		MIN	MAX	
$t_{pd}$	Propagation delay	A	B	-40°C to 85°C	0.5	84	0.5	51	0.5	38	0.5	15	0.5	10	0.5	9	0.5	7	0.5	8	ns	
				-40°C to 125°C	0.5	84	0.5	51	0.5	38	0.5	15	0.5	11	0.5	9	0.5	8	0.5	8		
		B	A	-40°C to 85°C	0.5	50	0.5	33	0.5	23	0.5	15	0.5	12	0.5	10	0.5	8	0.5	7		ns
				-40°C to 125°C	0.5	50	0.5	33	0.5	23	0.5	15	0.5	12	0.5	10	0.5	8	0.5	7		
$t_{dis}$	Disable time	DIR	A	-40°C to 85°C	0.5	26	0.5	26	0.5	26	0.5	26	0.5	26	0.5	26	0.5	26	0.5	26	ns	
				-40°C to 125°C	0.5	27	0.5	27	0.5	27	0.5	27	0.5	27	0.5	27	0.5	27	0.5	27		
		DIR	B	-40°C to 85°C	0.5	129	0.5	90	0.5	70	0.5	27	0.5	20	0.5	18	0.5	15	0.5	15	ns	
				-40°C to 125°C	0.5	129	0.5	90	0.5	71	0.5	28	0.5	21	0.5	19	0.5	16	0.5	16		
$t_{en}^{(1)}$	Enable time	DIR	A	-40°C to 85°C	0.5	177	0.5	177	0.5	177	0.5	177	0.5	177	0.5	177	0.5	177	0.5	177	ns	
				-40°C to 125°C	0.5	177	0.5	177	0.5	177	0.5	177	0.5	177	0.5	177	0.5	177	0.5	177		
		DIR	B	-40°C to 85°C	0.5	105	0.5	71	0.5	59	0.5	40	0.5	36	0.5	35	0.5	33	0.5	34	ns	
				-40°C to 125°C	0.5	105	0.5	71	0.5	59	0.5	41	0.5	37	0.5	36	0.5	34	0.5	35		

(1) The enable time is a calculated value, derived using the formula shown in the Enable Times section.

## 6.10 Switching Characteristics, $V_{CCA} = 1.5 \pm 0.1 \text{ V}$

See [Figure 5](#) and [Table 1](#) for test circuit and loading. See [Figure 6](#), [Figure 7](#), and [Figure 8](#) for measurement waveforms.

PARAMETER	FROM	TO	Test Conditions	B-Port Supply Voltage ( $V_{CCB}$ )												UNIT						
				0.7 ± 0.05 V		0.8 ± 0.04 V		0.9 ± 0.045 V		1.2 ± 0.1 V		1.5 ± 0.1 V		1.8 ± 0.15 V			2.5 ± 0.2 V		3.3 ± 0.3 V			
				MIN	MAX	MIN	MAX	MIN	MAX	MIN	MAX	MIN	MAX	MIN	MAX		MIN	MAX	MIN	MAX		
$t_{pd}$	Propagation delay	A	B	-40°C to 85°C	0.5	79	0.5	41	0.5	28	0.5	12	0.5	9	0.5	7	0.5	6	0.5	6	ns	
				-40°C to 125°C	0.5	79	0.5	41	0.5	28	0.5	12	0.5	9	0.5	8	0.5	6	0.5	6		
	B	A	-40°C to 85°C	0.5	50	0.5	28	0.5	18	0.5	10	0.5	9	0.5	8	0.5	6	0.5	5	ns		
			-40°C to 125°C	0.5	50	0.5	28	0.5	18	0.5	11	0.5	9	0.5	8	0.5	6	0.5	5			
$t_{dis}$	Disable time	DIR	A	-40°C to 85°C	0.5	18	0.5	18	0.5	18	0.5	18	0.5	18	0.5	18	0.5	18	0.5	18	ns	
				-40°C to 125°C	0.5	19	0.5	19	0.5	19	0.5	19	0.5	19	0.5	19	0.5	19	0.5	19		
		DIR	B	-40°C to 85°C	0.5	128	0.5	89	0.5	69	0.5	26	0.5	19	0.5	17	0.5	13	0.5	13		ns
				-40°C to 125°C	0.5	128	0.5	89	0.5	70	0.5	27	0.5	20	0.5	18	0.5	14	0.5	14		
$t_{en}^{(1)}$	Enable time	DIR	A	-40°C to 85°C	0.5	172	0.5	172	0.5	172	0.5	172	0.5	172	0.5	172	0.5	172	0.5	172	ns	
				-40°C to 125°C	0.5	172	0.5	172	0.5	172	0.5	172	0.5	172	0.5	172	0.5	172	0.5	172		
		DIR	B	-40°C to 85°C	0.5	92	0.5	54	0.5	42	0.5	31	0.5	27	0.5	25	0.5	24	0.5	24		ns
				-40°C to 125°C	0.5	92	0.5	54	0.5	42	0.5	31	0.5	28	0.5	26	0.5	25	0.5	25		

(1) The enable time is a calculated value, derived using the formula shown in the Enable Times section.

## 6.11 Switching Characteristics, $V_{CCA} = 1.8 \pm 0.15 \text{ V}$

See Figure 5 and Table 1 for test circuit and loading. See Figure 6, Figure 7, and Figure 8 for measurement waveforms.

PARAMETER	FROM	TO	Test Conditions	B-Port Supply Voltage ( $V_{CCB}$ )												UNIT					
				0.7 ± 0.05 V		0.8 ± 0.04 V		0.9 ± 0.045 V		1.2 ± 0.1 V		1.5 ± 0.1 V		1.8 ± 0.15 V			2.5 ± 0.2 V		3.3 ± 0.3 V		
				MIN	MAX	MIN	MAX	MIN	MAX	MIN	MAX	MIN	MAX	MIN	MAX		MIN	MAX	MIN	MAX	
$t_{pd}$	Propagation delay	A	B	-40°C to 85°C	0.5	78	0.5	40	0.5	24	0.5	10	0.5	8	0.5	7	0.5	5	0.5	5	ns
				-40°C to 125°C	0.5	78	0.5	40	0.5	24	0.5	10	0.5	8	0.5	7	0.5	6	0.5	5	
	B	A	-40°C to 85°C	0.5	56	0.5	27	0.5	16	0.5	9	0.5	7	0.5	7	0.5	5	0.5	4		
			-40°C to 125°C	0.5	56	0.5	27	0.5	16	0.5	9	0.5	8	0.5	7	0.5	5	0.5	5		
$t_{dis}$	Disable time	DIR	A	-40°C to 85°C	0.5	16	0.5	16	0.5	16	0.5	16	0.5	16	0.5	16	0.5	16	0.5	16	ns
				-40°C to 125°C	0.5	17	0.5	17	0.5	17	0.5	17	0.5	17	0.5	17	0.5	17	0.5	17	
	DIR	B	-40°C to 85°C	0.5	127	0.5	88	0.5	69	0.5	25	0.5	18	0.5	16	0.5	12	0.5	12		
			-40°C to 125°C	0.5	127	0.5	88	0.5	70	0.5	26	0.5	19	0.5	17	0.5	13	0.5	13		
$t_{en}^{(1)}$	Enable time	DIR	A	-40°C to 85°C	0.5	171	0.5	171	0.5	171	0.5	171	0.5	171	0.5	171	0.5	171	0.5	171	ns
				-40°C to 125°C	0.5	171	0.5	171	0.5	171	0.5	171	0.5	171	0.5	171	0.5	171	0.5	171	
	DIR	B	-40°C to 85°C	0.5	89	0.5	50	0.5	36	0.5	26	0.5	23	0.5	22	0.5	21	0.5	20		
			-40°C to 125°C	0.5	89	0.5	50	0.5	36	0.5	27	0.5	24	0.5	23	0.5	22	0.5	21		

(1) The enable time is a calculated value, derived using the formula shown in the Enable Times section.

## 6.12 Switching Characteristics, $V_{CCA} = 2.5 \pm 0.2 \text{ V}$

See [Figure 5](#) and [Table 1](#) for test circuit and loading. See [Figure 6](#), [Figure 7](#), and [Figure 8](#) for measurement waveforms.

PARAMETER	FROM	TO	Test Conditions	B-Port Supply Voltage ( $V_{CCB}$ )														UNIT			
				0.7 ± 0.05 V		0.8 ± 0.04 V		0.9 ± 0.045 V		1.2 ± 0.1 V		1.5 ± 0.1 V		1.8 ± 0.15 V		2.5 ± 0.2 V			3.3 ± 0.3 V		
				MIN	MAX	MIN	MAX	MIN	MAX	MIN	MAX	MIN	MAX	MIN	MAX	MIN	MAX		MIN	MAX	
$t_{pd}$	Propagation delay	A	B	-40°C to 85°C	0.5	77	0.5	38	0.5	21	0.5	8	0.5	6	0.5	5	0.5	5	0.5	4	ns
				-40°C to 125°C	0.5	77	0.5	38	0.5	21	0.5	8	0.5	6	0.5	5	0.5	5	0.5	5	
	B	A	-40°C to 85°C	0.5	71	0.5	28	0.5	15	0.5	7	0.5	6	0.5	5	0.5	5	0.5	4		
			-40°C to 125°C	0.5	71	0.5	28	0.5	15	0.5	8	0.5	6	0.5	6	0.5	5	0.5	4		
$t_{dis}$	Disable time	DIR	A	-40°C to 85°C	0.5	11	0.5	11	0.5	11	0.5	11	0.5	11	0.5	11	0.5	11	0.5	11	ns
				-40°C to 125°C	0.5	12	0.5	12	0.5	12	0.5	12	0.5	12	0.5	12	0.5	12	0.5	12	
	DIR	B	-40°C to 85°C	0.5	127	0.5	88	0.5	68	0.5	25	0.5	18	0.5	15	0.5	12	0.5	11		
			-40°C to 125°C	0.5	127	0.5	88	0.5	69	0.5	26	0.5	19	0.5	16	0.5	12	0.5	12		
$t_{en}^{(1)}$	Enable time	DIR	A	-40°C to 85°C	0.5	182	0.5	182	0.5	182	0.5	182	0.5	182	0.5	182	0.5	182	0.5	182	ns
				-40°C to 125°C	0.5	182	0.5	182	0.5	182	0.5	182	0.5	182	0.5	182	0.5	182	0.5	182	
		DIR	B	-40°C to 85°C	0.5	84	0.5	46	0.5	29	0.5	18	0.5	17	0.5	16	0.5	15	0.5	15	
				-40°C to 125°C	0.5	84	0.5	46	0.5	29	0.5	19	0.5	18	0.5	17	0.5	16	0.5	16	

(1) The enable time is a calculated value, derived using the formula shown in the Enable Times section.

### 6.13 Switching Characteristics, $V_{CCA} = 3.3 \pm 0.3 \text{ V}$

See Figure 5 and Table 1 for test circuit and loading. See Figure 6, Figure 7, and Figure 8 for measurement waveforms.

PARAMETER	FROM	TO	Test Conditions	B-Port Supply Voltage ( $V_{CCB}$ )														UNIT			
				0.7 ± 0.05 V		0.8 ± 0.04 V		0.9 ± 0.045 V		1.2 ± 0.1 V		1.5 ± 0.1 V		1.8 ± 0.15 V		2.5 ± 0.2 V			3.3 ± 0.3 V		
				MIN	MAX	MIN	MAX	MIN	MAX	MIN	MAX	MIN	MAX	MIN	MAX	MIN	MAX		MIN	MAX	
$t_{pd}$	Propagation delay	A	B	-40°C to 85°C	0.5	76	0.5	38	0.5	21	0.5	7	0.5	5	0.5	4	0.5	4	0.5	4	ns
				-40°C to 125°C	0.5	76	0.5	38	0.5	21	0.5	7	0.5	5	0.5	5	0.5	4	0.5	4	
	B	A	-40°C to 85°C	0.5	105	0.5	34	0.5	17	0.5	8	0.5	6	0.5	5	0.5	4	0.5	4		
			-40°C to 125°C	0.5	105	0.5	34	0.5	17	0.5	8	0.5	6	0.5	5	0.5	5	0.5	4		
$t_{dis}$	Disable time	DIR	A	-40°C to 85°C	0.5	10	0.5	10	0.5	10	0.5	10	0.5	10	0.5	10	0.5	10	0.5	10	ns
				-40°C to 125°C	0.5	11	0.5	11	0.5	11	0.5	11	0.5	11	0.5	11	0.5	11	0.5	11	
	DIR	B	-40°C to 85°C	0.5	128	0.5	88	0.5	68	0.5	24	0.5	17	0.5	15	0.5	11	0.5	11		
			-40°C to 125°C	0.5	128	0.5	88	0.5	69	0.5	26	0.5	19	0.5	16	0.5	12	0.5	11		
$t_{en}^{(1)}$	Enable time	DIR	A	-40°C to 85°C	0.5	218	0.5	218	0.5	218	0.5	218	0.5	218	0.5	218	0.5	218	0.5	218	ns
				-40°C to 125°C	0.5	218	0.5	218	0.5	218	0.5	218	0.5	218	0.5	218	0.5	218	0.5	218	
	DIR	B	-40°C to 85°C	0.5	83	0.5	45	0.5	28	0.5	17	0.5	15	0.5	14	0.5	14	0.5	14		
			-40°C to 125°C	0.5	83	0.5	45	0.5	28	0.5	18	0.5	16	0.5	15	0.5	15	0.5	15		

(1) The enable time is a calculated value, derived using the formula shown in the Enable Times section.



### 6.14 Operating Characteristics: $T_A = 25^\circ\text{C}$

PARAMETER		TEST CONDITIONS	$V_{CCA}$	$V_{CCB}$	MIN	TYP	MAX	UNIT
$C_{pdA}$	Power Dissipation Capacitance per transceiver (A to B)	CL = 0, RL = Open f = 1 MHz, tr = tf = 1 ns	0.7 V	0.7 V		2.2		pF
			0.8 V	0.8 V		2.0		
			0.9 V	0.9 V		2.0		
			1.2 V	1.2 V		2.0		
			1.5 V	1.5 V		2.0		
			1.8 V	1.8 V		2.1		
			2.5 V	2.5 V		2.5		
			3.3 V	3.3 V		3.0		
	Power Dissipation Capacitance per transceiver (B to A)	CL = 0, RL = Open f = 1 MHz, tr = tf = 1 ns	0.7 V	0.7 V		10.6		pF
			0.8 V	0.8 V		10.7		
			0.9 V	0.9 V		10.6		
			1.2 V	1.2 V		10.8		
			1.5 V	1.5 V		11.1		
			1.8 V	1.8 V		12.2		
2.5 V			2.5 V		15.9			
3.3 V			3.3 V		19.6			
$C_{pdB}$	Power Dissipation Capacitance per transceiver (A to B)	CL = 0, RL = Open f = 1 MHz, tr = tf = 1 ns	0.7 V	0.7 V		10.6		pF
			0.8 V	0.8 V		10.7		
			0.9 V	0.9 V		10.6		
			1.2 V	1.2 V		10.8		
			1.5 V	1.5 V		11.1		
			1.8 V	1.8 V		12.2		
			2.5 V	2.5 V		15.8		
			3.3 V	3.3 V		19.3		
	Power Dissipation Capacitance per transceiver (B to A)	CL = 0, RL = Open f = 1 MHz, tr = tf = 1 ns	0.7 V	0.7 V		2.2		pF
			0.8 V	0.8 V		2.0		
			0.9 V	0.9 V		2.0		
			1.2 V	1.2 V		2.0		
			1.5 V	1.5 V		2.0		
			1.8 V	1.8 V		2.1		
2.5 V			2.5 V		2.5			
3.3 V			3.3 V		3.0			

### 6.15 Typical Characteristics



图 6-1. Typical ( $T_A=25^\circ\text{C}$ ) Output High Voltage ( $V_{OH}$ ) vs Source Current ( $I_{OH}$ )



图 6-2. Typical ( $T_A=25^\circ\text{C}$ ) Output High Voltage ( $V_{OH}$ ) vs Source Current ( $I_{OH}$ )

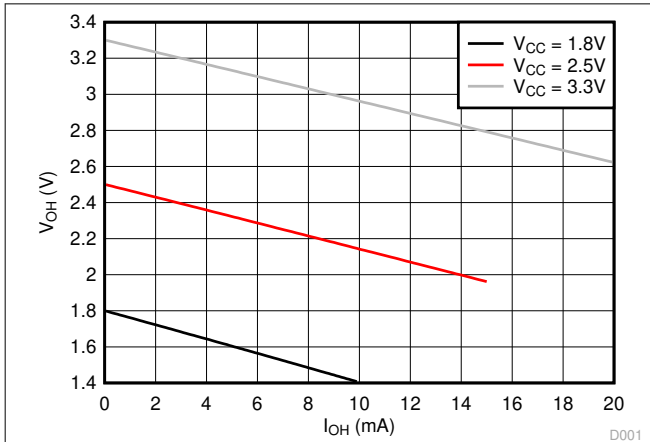

图 6-3. Typical ( $T_A=25^\circ\text{C}$ ) Output Low Voltage ( $V_{OL}$ ) vs Sink Current ( $I_{OL}$ )

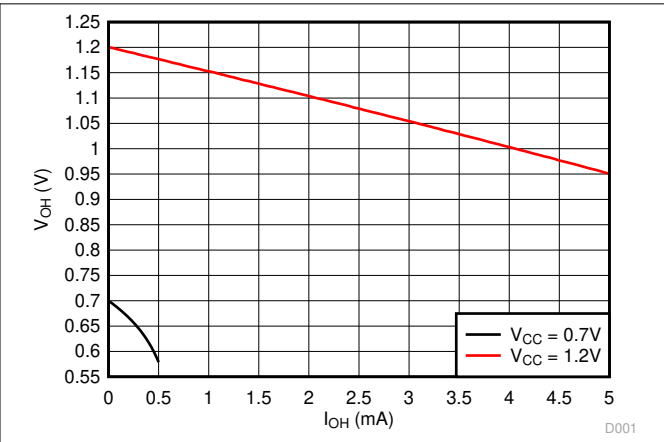

图 6-4. Typical ( $T_A=25^\circ\text{C}$ ) Output Low Voltage ( $V_{OL}$ ) vs Sink Current ( $I_{OL}$ )

## 7 Parameter Measurement Information

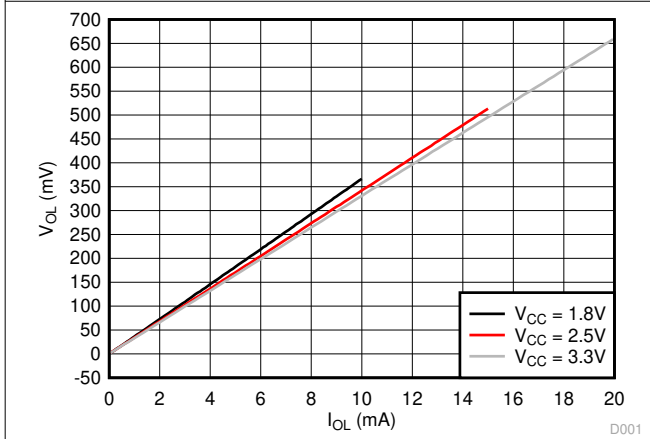
### 7.1 Load Circuit and Voltage Waveforms

Unless otherwise noted, all input pulses are supplied by generators having the following characteristics:

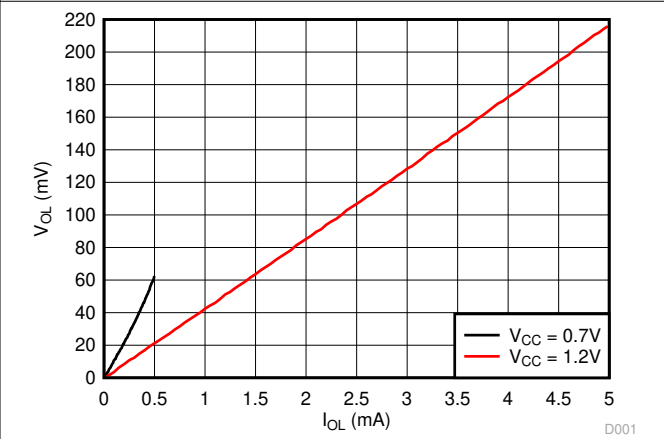
- $f = 1 \text{ MHz}$
- $Z_O = 50 \ \Omega$
- $dv/dt \leq 1 \text{ ns/V}$

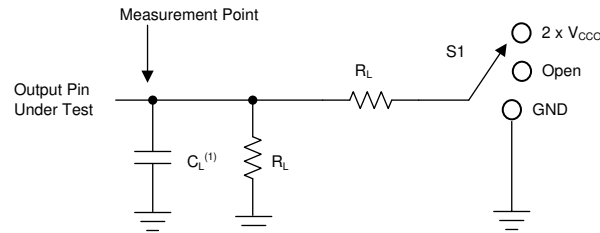

A.  $C_L$  includes probe and jig capacitance.

图 7-1. Load Circuit

表 7-1. Load Circuit Conditions

Parameter	$V_{CCO}$	$R_L$	$C_L$	$S_1$	$V_{TP}$
$\Delta t / \Delta V$ Input transition rise or fall rate	0.65 V - 3.6 V	1 M $\Omega$	15 pF	Open	N/A
$t_{pd}$ Propagation (delay) time	1.1 V - 3.6 V	2 k $\Omega$	15 pF	Open	N/A
	0.65 V - 0.95 V	20 k $\Omega$	15 pF	Open	N/A
$t_{en}, t_{dis}$ Enable time, disable time	3 V - 3.6 V	2 k $\Omega$	15 pF	$2 \times V_{CCO}$	0.3 V
	1.65 V - 2.7 V	2 k $\Omega$	15 pF	$2 \times V_{CCO}$	0.15 V
	1.1 V - 1.6 V	2 k $\Omega$	15 pF	$2 \times V_{CCO}$	0.1 V
	0.65 V - 0.95 V	20 k $\Omega$	15 pF	$2 \times V_{CCO}$	0.1 V
$t_{en}, t_{dis}$ Enable time, disable time	3 V - 3.6 V	2 k $\Omega$	15 pF	GND	0.3 V
	1.65 V - 2.7 V	2 k $\Omega$	15 pF	GND	0.15 V
	1.1 V - 1.6 V	2 k $\Omega$	15 pF	GND	0.1 V
	0.65 V - 0.95 V	20 k $\Omega$	15 pF	GND	0.1 V

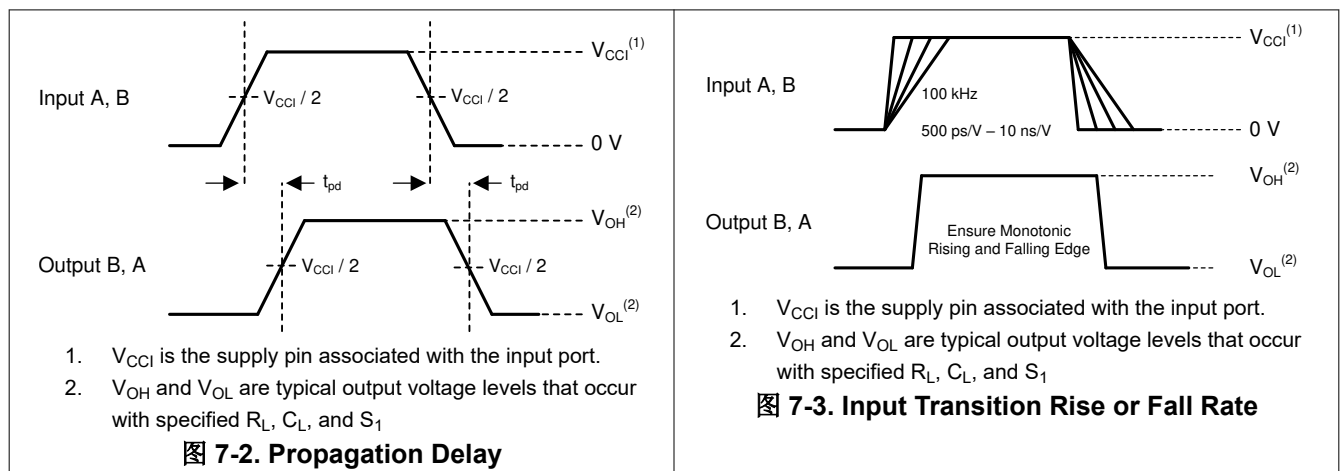

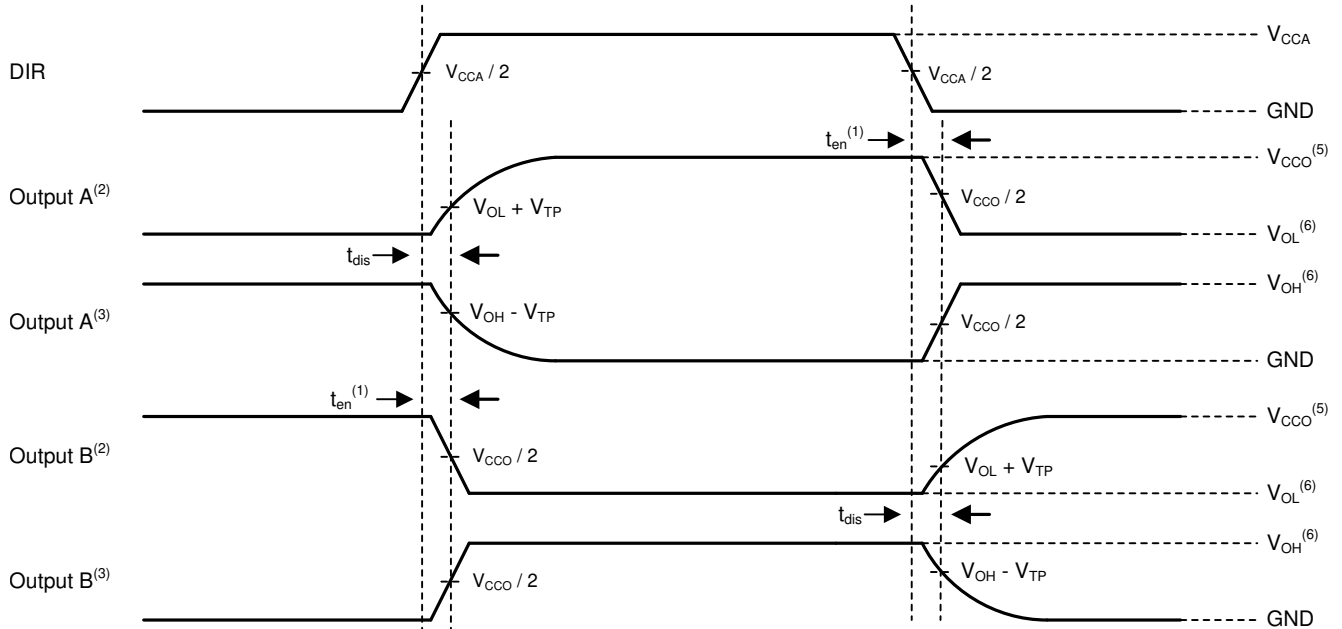

- A. Illustrative purposes only. Enable Time is a calculation as described in the Application Information section.
- B. Output waveform on the condition that input is driven to a valid Logic Low.
- C. Output waveform on the condition that input is driven to a valid Logic High.
- D.  $V_{CCI}$  is the supply pin associated with the input port.
- E.  $V_{CCO}$  is the supply pin associated with the output port.
- F.  $V_{OH}$  and  $V_{OL}$  are typical output voltage levels with specified  $R_L$ ,  $C_L$ , and  $S_1$ .

**图 7-4. Enable Time And Disable Time**

## 8 Detailed Description

### 8.1 Overview

The SN74AXC2T45 is a 2-bit, dual-supply non-inverting bidirectional voltage level translation device. Ax pins and the DIR pin are referenced to  $V_{CCA}$  logic levels, and Bx pins are referenced to  $V_{CCB}$  logic levels. The A port is able to accept I/O voltages ranging from 0.65 V to 3.6 V, while the B port can accept I/O voltages from 0.65 V to 3.6 V. A high on DIR enables data transmission from A to B and a low on DIR enables data transmission from B to A. See [Device Functional Modes](#) for a summary of the operation of the control logic.

### 8.2 Functional Block Diagram

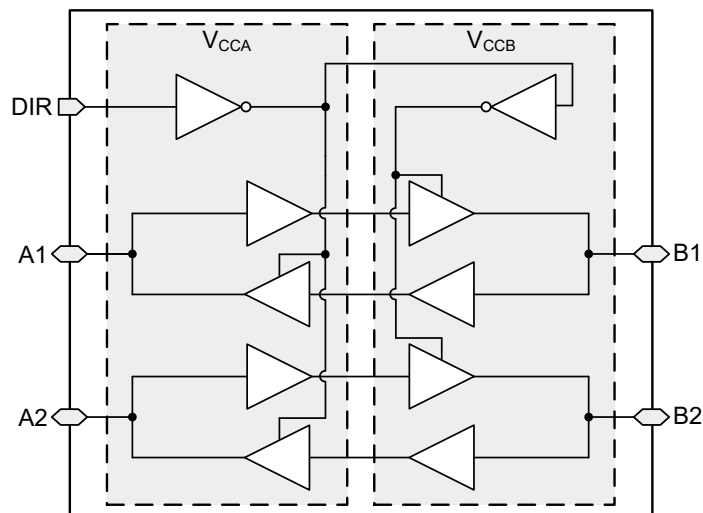

### 8.3 Feature Description

#### 8.3.1 Standard CMOS Inputs

Standard CMOS inputs are high impedance and are typically modeled as a resistor in parallel with the input capacitance given in [节 6.5](#). The worst case resistance is calculated with the maximum input voltage, given in [节 6.1](#), and the maximum input leakage current, given in the [节 6.5](#), using Ohm's law ( $R = V \div I$ ).

Signals applied to the inputs need to have fast edge rates, as defined by  $\Delta t / \Delta v$  in [节 6.3](#) to avoid excessive current consumption and oscillations. If a slow or noisy input signal is required, a device with a Schmitt-trigger input should be used to condition the input signal prior to the standard CMOS input.

#### 8.3.2 Balanced High-Drive CMOS Push-Pull Outputs

A balanced output allows the device to sink and source similar currents. The high drive capability of this device creates fast edges into light loads so routing and load conditions should be considered to prevent ringing. Additionally, the outputs of this device are capable of driving larger currents than the device can sustain without being damaged. The electrical and thermal limits defined in [节 6.1](#) must be followed at all times.

#### 8.3.3 Partial Power Down ( $I_{off}$ )

The inputs and outputs for this device enter a high-impedance state when the device is powered down, inhibiting current backflow into the device. The maximum leakage into or out of any input or output pin on the device is specified by  $I_{off}$  in [节 6.5](#).

#### 8.3.4 $V_{CC}$ Isolation

The inputs and outputs for this device enter a high-impedance state when either supply is  $<100$  mV.

#### 8.3.5 Over-voltage Tolerant Inputs

Input signals to this device can be driven above the supply voltage so long as they remain below the maximum input voltage value specified in [节 6.3](#).

### 8.3.6 Glitch-Free Power Supply Sequencing

Either supply rail may be powered on or off in any order without producing a glitch on the I/Os (that is, where the output erroneously transitions to  $V_{CC}$  when it should be held low). Glitches of this nature can be misinterpreted by a peripheral as a valid data bit, which could trigger a false device reset of the peripheral, a false device configuration of the peripheral, or even a false data initialization by the peripheral. For more information regarding the power up glitch performance of the AXC family of level translators, see the [Glitch Free Power Sequencing With AXC Level Translators](#) application report.

### 8.3.7 Negative Clamping Diodes

The inputs and outputs to this device have negative clamping diodes as depicted in [图 8-1](#).

**CAUTION**

Voltages beyond the values specified in [节 6.1](#) table can cause damage to the device. The input negative-voltage and output voltage ratings may be exceeded if the input and output clamp-current ratings are observed.

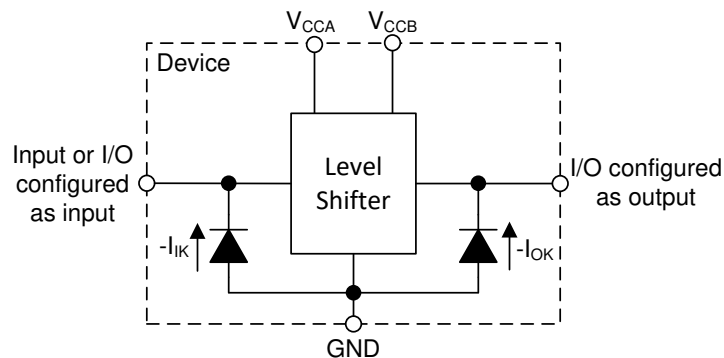

**图 8-1. Electrical Placement of Clamping Diodes for Each Input and Output**

### 8.3.8 Fully Configurable Dual-Rail Design

Both the  $V_{CCA}$  and  $V_{CCB}$  pins can be supplied at any voltage from 0.65 V to 3.6 V, making the device suitable for translating between any of the voltage nodes (0.7 V, 0.8 V, 0.9 V, 1.2 V, 1.8 V, 2.5 V and 3.3 V).

### 8.3.9 Supports High-Speed Translation

The SN74AXC2T45 device can support high data-rate applications. The translated signal data rate can be up to 380 Mbps when the signal is translated from 1.8 V to 3.3 V.

## 8.4 Device Functional Modes

**表 8-1. Function Table<sup>(1)</sup>**

CONTROL INPUT DIR	Port Status		OPERATION
	A PORT	B PORT	
L	Output (Enabled)	Input (Hi-Z)	B data to A bus
H	Input (Hi-Z)	Output (Enabled)	A data to B bus

(1) Input circuits of the data I/O's are always active.

## 9 Application and Implementation

### Note

Information in the following applications sections is not part of the TI component specification, and TI does not warrant its accuracy or completeness. TI's customers are responsible for determining suitability of components for their purposes. Customers should validate and test their design implementation to confirm system functionality.

### 9.1 Application Information

The SN74AXC2T45 device can be used in level-translation applications for interfacing devices or systems operating at different interface voltages with one another. The SN74AXC2T45 device is ideal for use in applications where a push-pull driver is connected to the data I/Os. The max data rate can be up to 380 Mbps when device translates a signal from 1.8 V to 3.3 V.

One example application is shown in 图 9-1, where the SN74AXC2T45 device is used to translate low voltage error signals from a CPU to a higher voltage signal to properly drive the inputs of a system controller, thus alerting the system of any CPU errors such as overheating or other catastrophic processor errors.

#### 9.1.1 Enable Times

Calculate the enable times for the SN74AXC2T45 using the following formulas:

$$t_{A\_en}(\text{DIR to A}) = t_{dis}(\text{DIR to B}) + t_{pd}(\text{B to A}) \quad (1)$$

$$t_{B\_en}(\text{DIR to A}) = t_{dis}(\text{DIR to A}) + t_{pd}(\text{A to B}) \quad (2)$$

In a bidirectional application, these enable times provide the maximum delay time from the time the DIR bit is switched until an output is expected. For example, if the SN74AXC2T45 initially is transmitting from A to B, then the DIR bit is switched; the B port of the device must be disabled ( $t_{dis}$ ) before presenting it with an input. After the B port has been disabled, an input signal applied to it appears on the corresponding A port after the specified propagation delay ( $t_{pd}$ ). To avoid bus contention care should be taken to not apply an input signal prior to the output port being disabled ( $t_{dis}$  maximum).

### 9.2 Typical Application



图 9-1. Processor Error Application

### 9.2.1 Design Requirements

For this design example, use the parameters listed in 表 9-1.

表 9-1. Design Parameters

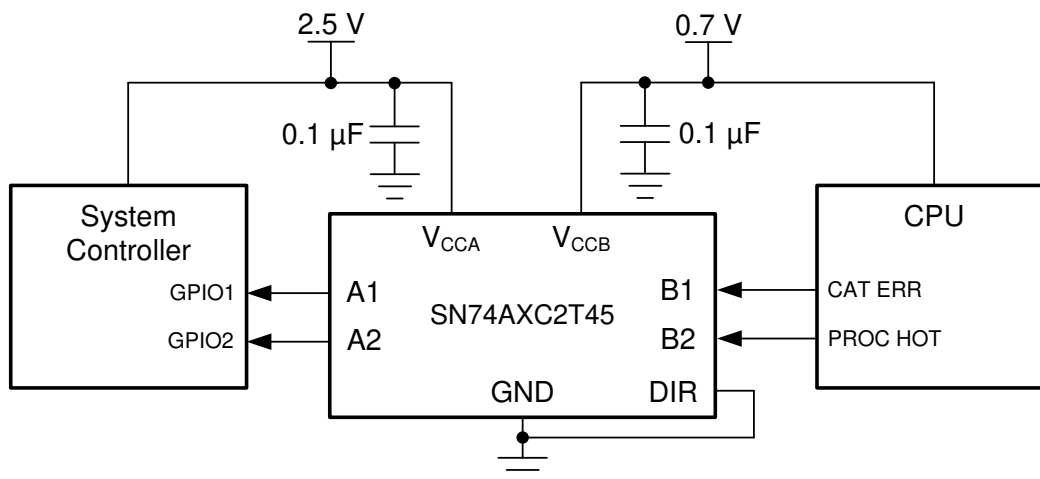
DESIGN PARAMETERS	EXAMPLE VALUES
Input voltage range	0.65 V to 3.6 V
Output voltage range	0.65 V to 3.6 V

### 9.2.2 Detailed Design Procedure

To begin the design process, determine the following:

- Input voltage range
  - Use the supply voltage of the device that is driving the SN74AXC2T45 device to determine the input voltage range. For a valid logic-high, the value must exceed the high-level input voltage ( $V_{IH}$ ) of the input port. For a valid logic low the value must be less than the low-level input voltage ( $V_{IL}$ ) of the input port.
- Output voltage range
  - Use the supply voltage of the device that the SN74AXC2T45 device is driving to determine the output voltage range.

### 9.2.3 Application Curve



图 9-2. Up Translation at 2.5 MHz (0.7 V to 3.3 V)



## 10 Power Supply Recommendations

Always apply a ground reference to the GND pins first. This device is designed for glitch free power sequencing without any supply sequencing requirements such as ramp order or ramp rate.

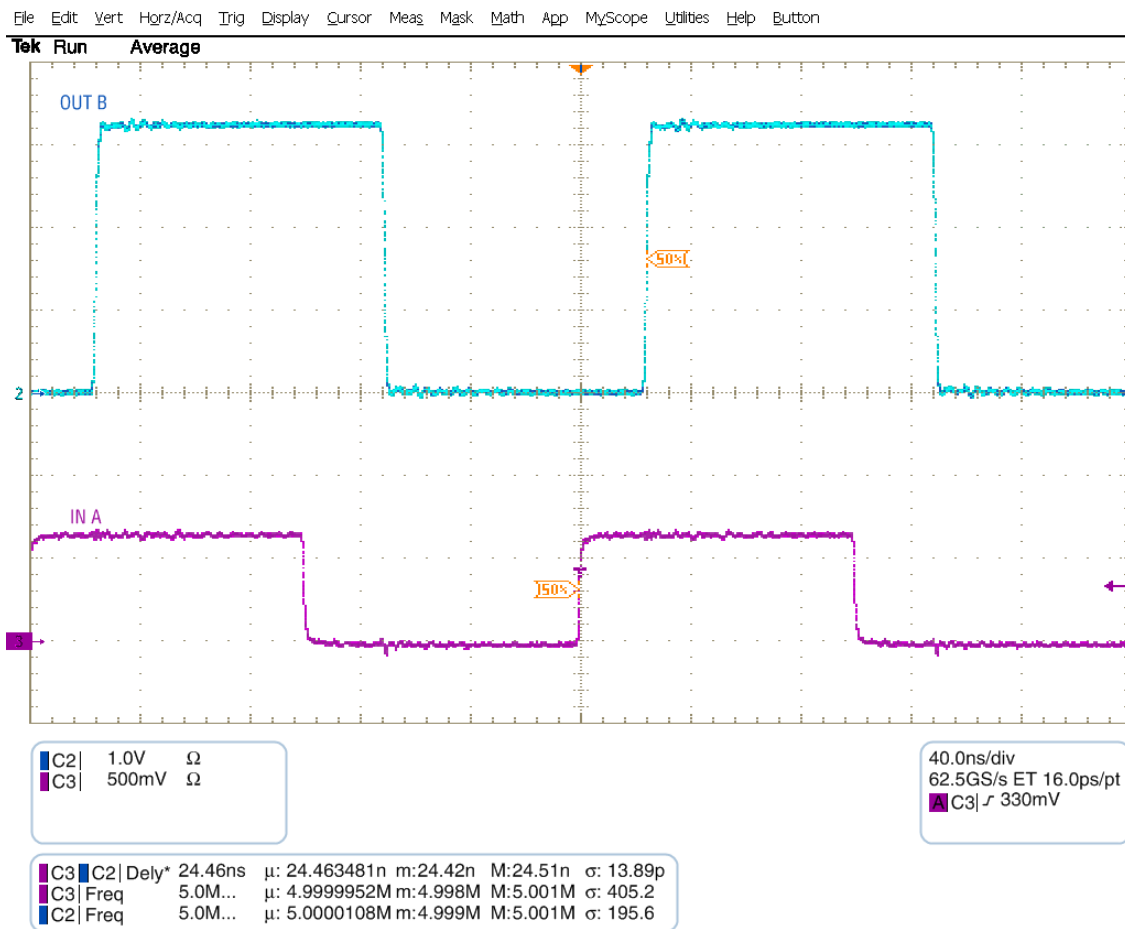
This device is designed with various power supply sequencing methods in mind to help prevent unintended triggering of downstream devices. For more information regarding the power up glitch performance of the AXC family of level translators, see the [Glitch Free Power Sequencing With AXC Level Translators](#) application report

## 11 Layout

### 11.1 Layout Guidelines

To ensure reliability of the device, following common printed-circuit board layout guidelines are recommended:

- Use bypass capacitors on the power supply pins and place them as close to the device as possible. A 0.1  $\mu\text{F}$  capacitor is recommended, but transient performance can be improved by having both 1  $\mu\text{F}$  and 0.1  $\mu\text{F}$  capacitors in parallel as bypass capacitors.
- Use short trace lengths to avoid excessive loading.

### 11.2 Layout Example

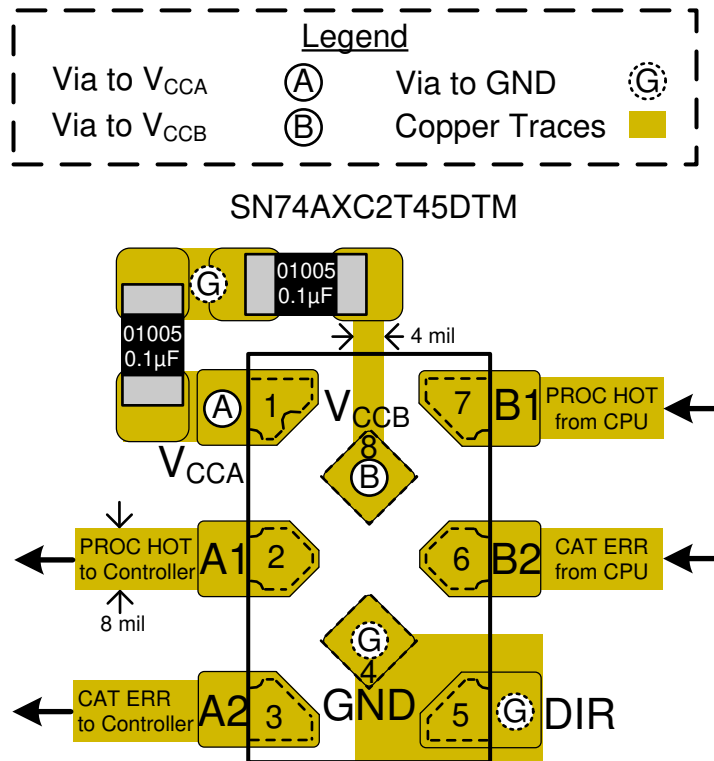

## 12 Device and Documentation Support

### 12.1 Documentation Support

#### 12.1.1 Related Documentation

For related documentation see the following:

- Texas Instruments, [Implications of Slow or Floating CMOS Inputs application report](#)
- Texas Instruments, [Power Sequencing for AX Family of Devices application report](#)

#### 12.2 接收文档更新通知

要接收文档更新通知，请导航至 [ti.com](http://ti.com) 上的器件产品文件夹。点击 [订阅更新](#) 进行注册，即可每周接收产品信息更改摘要。有关更改的详细信息，请查看任何已修订文档中包含的修订历史记录。

#### 12.3 支持资源

TI E2E™ 支持论坛是工程师的重要参考资料，可直接从专家获得快速、经过验证的解答和设计帮助。搜索现有解答或提出自己的问题可获得所需的快速设计帮助。

链接的内容由各个贡献者“按原样”提供。这些内容并不构成 TI 技术规范，并且不一定反映 TI 的观点；请参阅 TI 的《使用条款》。

#### 12.4 Trademarks

TI E2E™ is a trademark of Texas Instruments.

所有商标均为其各自所有者的财产。

#### 12.5 Electrostatic Discharge Caution



This integrated circuit can be damaged by ESD. Texas Instruments recommends that all integrated circuits be handled with appropriate precautions. Failure to observe proper handling and installation procedures can cause damage.

ESD damage can range from subtle performance degradation to complete device failure. Precision integrated circuits may be more susceptible to damage because very small parametric changes could cause the device not to meet its published specifications.

#### 12.6 Glossary

[TI Glossary](#) This glossary lists and explains terms, acronyms, and definitions.

## 13 Mechanical, Packaging, and Orderable Information

The following pages include mechanical, packaging, and orderable information. This information is the most current data available for the designated devices. This data is subject to change without notice and revision of this document. For browser-based versions of this data sheet, refer to the left-hand navigation.

## 重要声明和免责声明

TI 提供技术和可靠性数据 (包括数据表)、设计资源 (包括参考设计)、应用或其他设计建议、网络工具、安全信息和其他资源, 不保证没有瑕疵且不做任何明示或暗示的担保, 包括但不限于对适销性、某特定用途方面的适用性或不侵犯任何第三方知识产权的暗示担保。

这些资源可供使用 TI 产品进行设计的熟练开发人员使用。您将自行承担以下全部责任: (1) 针对您的应用选择合适的 TI 产品, (2) 设计、验证并测试您的应用, (3) 确保您的应用满足相应标准以及任何其他安全、安保或其他要求。这些资源如有变更, 恕不另行通知。TI 授权您仅可将这些资源用于研发本资源所述的 TI 产品的应用。严禁对这些资源进行其他复制或展示。您无权使用任何其他 TI 知识产权或任何第三方知识产权。您应全额赔偿因在这些资源的使用中对 TI 及其代表造成的任何索赔、损害、成本、损失和债务, TI 对此概不负责。

TI 提供的产品受 TI 的销售条款 (<https://www.ti.com/legal/termsofsale.html>) 或 [ti.com](https://www.ti.com) 上其他适用条款/TI 产品随附的其他适用条款的约束。TI 提供这些资源并不会扩展或以其他方式更改 TI 针对 TI 产品发布的适用的担保或担保免责声明。

邮寄地址: Texas Instruments, Post Office Box 655303, Dallas, Texas 75265

Copyright © 2021, 德州仪器 (TI) 公司

**PACKAGING INFORMATION**

Orderable Device	Status (1)	Package Type	Package Drawing	Pins	Package Qty	Eco Plan (2)	Lead finish/ Ball material (6)	MSL Peak Temp (3)	Op Temp (°C)	Device Marking (4/5)	Samples
SN74AXC2T45DCTR	ACTIVE	SM8	DCT	8	3000	RoHS & Green	NIPDAU	Level-1-260C-UNLIM	-40 to 125	1H6 G	<a href="#">Samples</a>
SN74AXC2T45DCUR	ACTIVE	VSSOP	DCU	8	3000	RoHS & Green	SN	Level-1-260C-UNLIM	-40 to 125	22HT	<a href="#">Samples</a>
SN74AXC2T45DTMR	ACTIVE	X2SON	DTM	8	5000	RoHS & Green	NIPDAU   NIPDAUAG	Level-1-260C-UNLIM	-40 to 125	1FP	<a href="#">Samples</a>

(1) The marketing status values are defined as follows:

**ACTIVE:** Product device recommended for new designs.

**LIFEBUY:** TI has announced that the device will be discontinued, and a lifetime-buy period is in effect.

**NRND:** Not recommended for new designs. Device is in production to support existing customers, but TI does not recommend using this part in a new design.

**PREVIEW:** Device has been announced but is not in production. Samples may or may not be available.

**OBSOLETE:** TI has discontinued the production of the device.

(2) **RoHS:** TI defines "RoHS" to mean semiconductor products that are compliant with the current EU RoHS requirements for all 10 RoHS substances, including the requirement that RoHS substance do not exceed 0.1% by weight in homogeneous materials. Where designed to be soldered at high temperatures, "RoHS" products are suitable for use in specified lead-free processes. TI may reference these types of products as "Pb-Free".

**RoHS Exempt:** TI defines "RoHS Exempt" to mean products that contain lead but are compliant with EU RoHS pursuant to a specific EU RoHS exemption.

**Green:** TI defines "Green" to mean the content of Chlorine (Cl) and Bromine (Br) based flame retardants meet JS709B low halogen requirements of <=1000ppm threshold. Antimony trioxide based flame retardants must also meet the <=1000ppm threshold requirement.

(3) MSL, Peak Temp. - The Moisture Sensitivity Level rating according to the JEDEC industry standard classifications, and peak solder temperature.

(4) There may be additional marking, which relates to the logo, the lot trace code information, or the environmental category on the device.

(5) Multiple Device Markings will be inside parentheses. Only one Device Marking contained in parentheses and separated by a "~" will appear on a device. If a line is indented then it is a continuation of the previous line and the two combined represent the entire Device Marking for that device.

(6) Lead finish/Ball material - Orderable Devices may have multiple material finish options. Finish options are separated by a vertical ruled line. Lead finish/Ball material values may wrap to two lines if the finish value exceeds the maximum column width.

**Important Information and Disclaimer:**The information provided on this page represents TI's knowledge and belief as of the date that it is provided. TI bases its knowledge and belief on information provided by third parties, and makes no representation or warranty as to the accuracy of such information. Efforts are underway to better integrate information from third parties. TI has taken and continues to take reasonable steps to provide representative and accurate information but may not have conducted destructive testing or chemical analysis on incoming materials and chemicals. TI and TI suppliers consider certain information to be proprietary, and thus CAS numbers and other limited information may not be available for release.

In no event shall TI's liability arising out of such information exceed the total purchase price of the TI part(s) at issue in this document sold by TI to Customer on an annual basis.

**OTHER QUALIFIED VERSIONS OF SN74AXC2T45 :**

- Automotive : [SN74AXC2T45-Q1](#)

NOTE: Qualified Version Definitions:

- Automotive - Q100 devices qualified for high-reliability automotive applications targeting zero defects

**TAPE AND REEL INFORMATION**

**QUADRANT ASSIGNMENTS FOR PIN 1 ORIENTATION IN TAPE**



\*All dimensions are nominal

Device	Package Type	Package Drawing	Pins	SPQ	Reel Diameter (mm)	Reel Width W1 (mm)	A0 (mm)	B0 (mm)	K0 (mm)	P1 (mm)	W (mm)	Pin1 Quadrant
SN74AXC2T45DCTR	SM8	DCT	8	3000	177.8	12.4	3.45	4.4	1.45	4.0	12.0	Q3
SN74AXC2T45DCUR	VSSOP	DCU	8	3000	178.0	9.0	2.25	3.35	1.05	4.0	8.0	Q3
SN74AXC2T45DTMR	X2SON	DTM	8	5000	178.0	8.4	0.93	1.49	0.43	2.0	8.0	Q1
SN74AXC2T45DTMR	X2SON	DTM	8	5000	180.0	9.5	0.93	1.49	0.43	2.0	8.0	Q1

**TAPE AND REEL BOX DIMENSIONS**

\*All dimensions are nominal

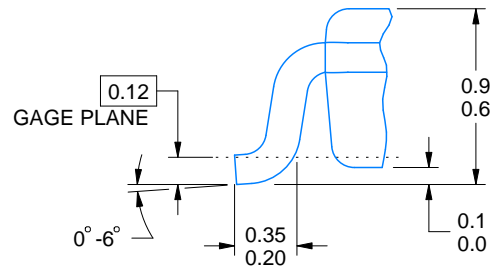
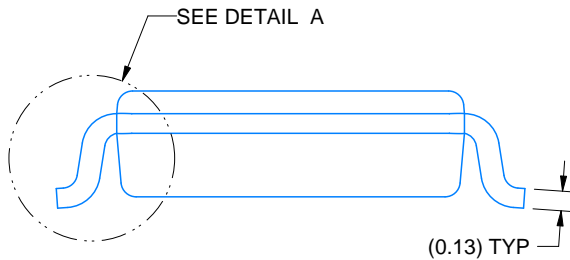
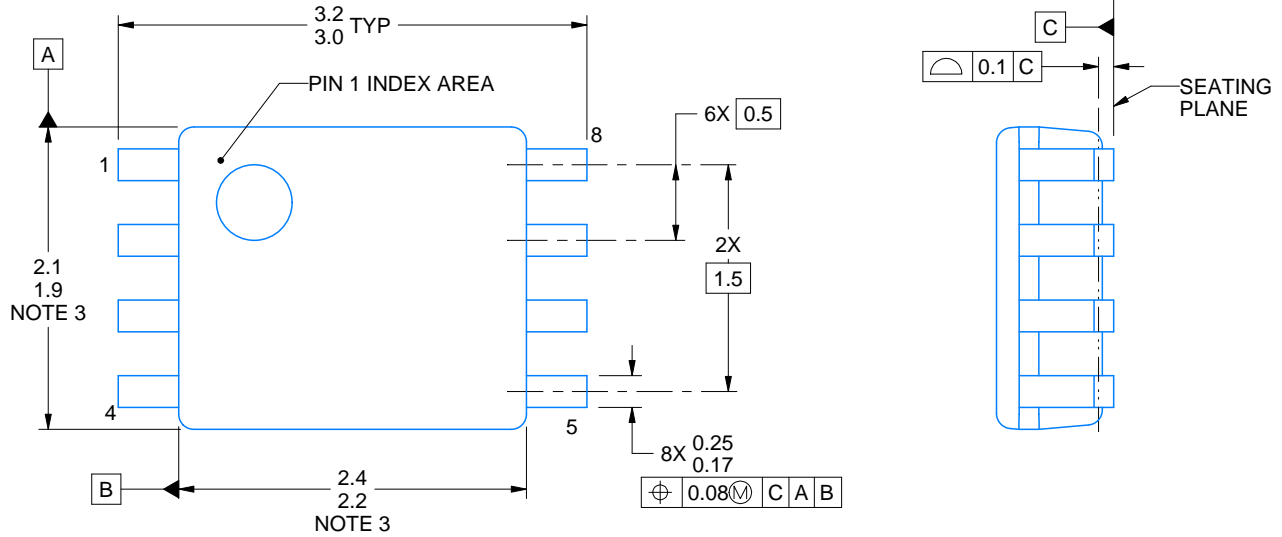
Device	Package Type	Package Drawing	Pins	SPQ	Length (mm)	Width (mm)	Height (mm)
SN74AXC2T45DCTR	SM8	DCT	8	3000	183.0	183.0	20.0
SN74AXC2T45DCUR	VSSOP	DCU	8	3000	180.0	180.0	18.0
SN74AXC2T45DTMR	X2SON	DTM	8	5000	205.0	200.0	33.0
SN74AXC2T45DTMR	X2SON	DTM	8	5000	189.0	185.0	36.0



DETAIL A TYPICAL

4225266/A 09/2014

NOTES:

1. All linear dimensions are in millimeters. Any dimensions in parenthesis are for reference only. Dimensioning and tolerancing per ASME Y14.5M.
2. This drawing is subject to change without notice.
3. This dimension does not include mold flash, protrusions, or gate burrs. Mold flash, protrusions, or gate burrs shall not exceed 0.15 mm per side.
4. Reference JEDEC registration MO-187 variation CA.



# EXAMPLE BOARD LAYOUT

DCU0008A

VSSOP - 0.9 mm max height

SMALL OUTLINE PACKAGE



LAND PATTERN EXAMPLE  
EXPOSED METAL SHOWN  
SCALE: 25X



4225266/A 09/2014

NOTES: (continued)

- 5. Publication IPC-7351 may have alternate designs.
- 6. Solder mask tolerances between and around signal pads can vary based on board fabrication site.

# EXAMPLE STENCIL DESIGN

DCU0008A

VSSOP - 0.9 mm max height

SMALL OUTLINE PACKAGE



SOLDER PASTE EXAMPLE  
BASED ON 0.125 mm THICK STENCIL  
SCALE: 25X

4225266/A 09/2014

NOTES: (continued)

7. Laser cutting apertures with trapezoidal walls and rounded corners may offer better paste release. IPC-7525 may have alternate design recommendations.
8. Board assembly site may have different recommendations for stencil design.



4220784/C 06/2021

NOTES:

1. All linear dimensions are in millimeters. Dimensions in parenthesis are for reference only. Dimensioning and tolerancing per ASME Y14.5M.
2. This drawing is subject to change without notice.
3. This dimension does not include mold flash, protrusions, or gate burrs. Mold flash, protrusions, or gate burrs shall not exceed 0.15 mm per side.
4. This dimension does not include interlead flash. Interlead flash shall not exceed 0.25 mm per side.

# EXAMPLE BOARD LAYOUT

DCT0008A

SSOP - 1.3 mm max height

SMALL OUTLINE PACKAGE

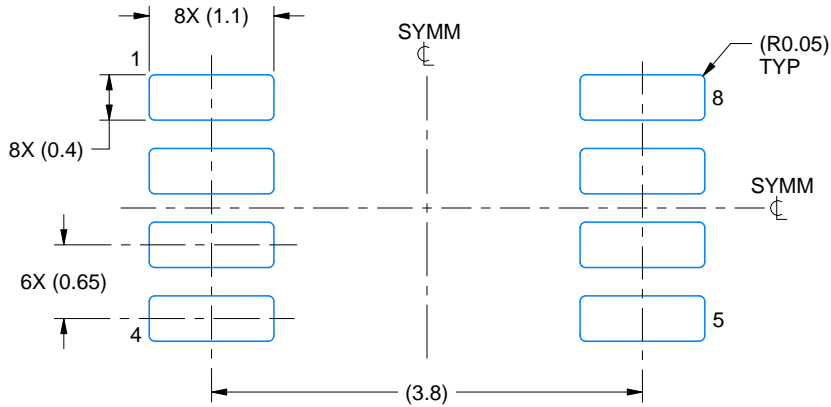

LAND PATTERN EXAMPLE  
EXPOSED METAL SHOWN  
SCALE:15X

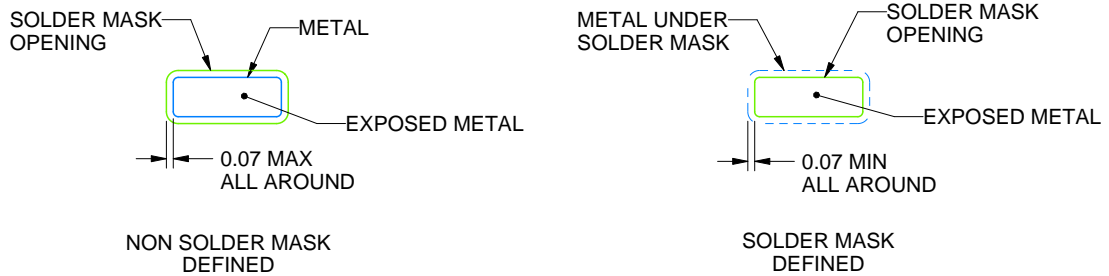

SOLDER MASK DETAILS

4220784/C 06/2021

NOTES: (continued)

- 5. Publication IPC-7351 may have alternate designs.
- 6. Solder mask tolerances between and around signal pads can vary based on board fabrication site.

# EXAMPLE STENCIL DESIGN

DCT0008A

SSOP - 1.3 mm max height

SMALL OUTLINE PACKAGE



SOLDER PASTE EXAMPLE  
BASED ON 0.125 mm THICK STENCIL  
SCALE:15X

4220784/C 06/2021

NOTES: (continued)

7. Laser cutting apertures with trapezoidal walls and rounded corners may offer better paste release. IPC-7525 may have alternate design recommendations.
8. Board assembly site may have different recommendations for stencil design.

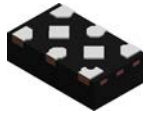

# PACKAGE OUTLINE

## DTM0008A

### X2SON - 0.4 mm max height

PLASTIC SMALL OUTLINE - NO LEAD

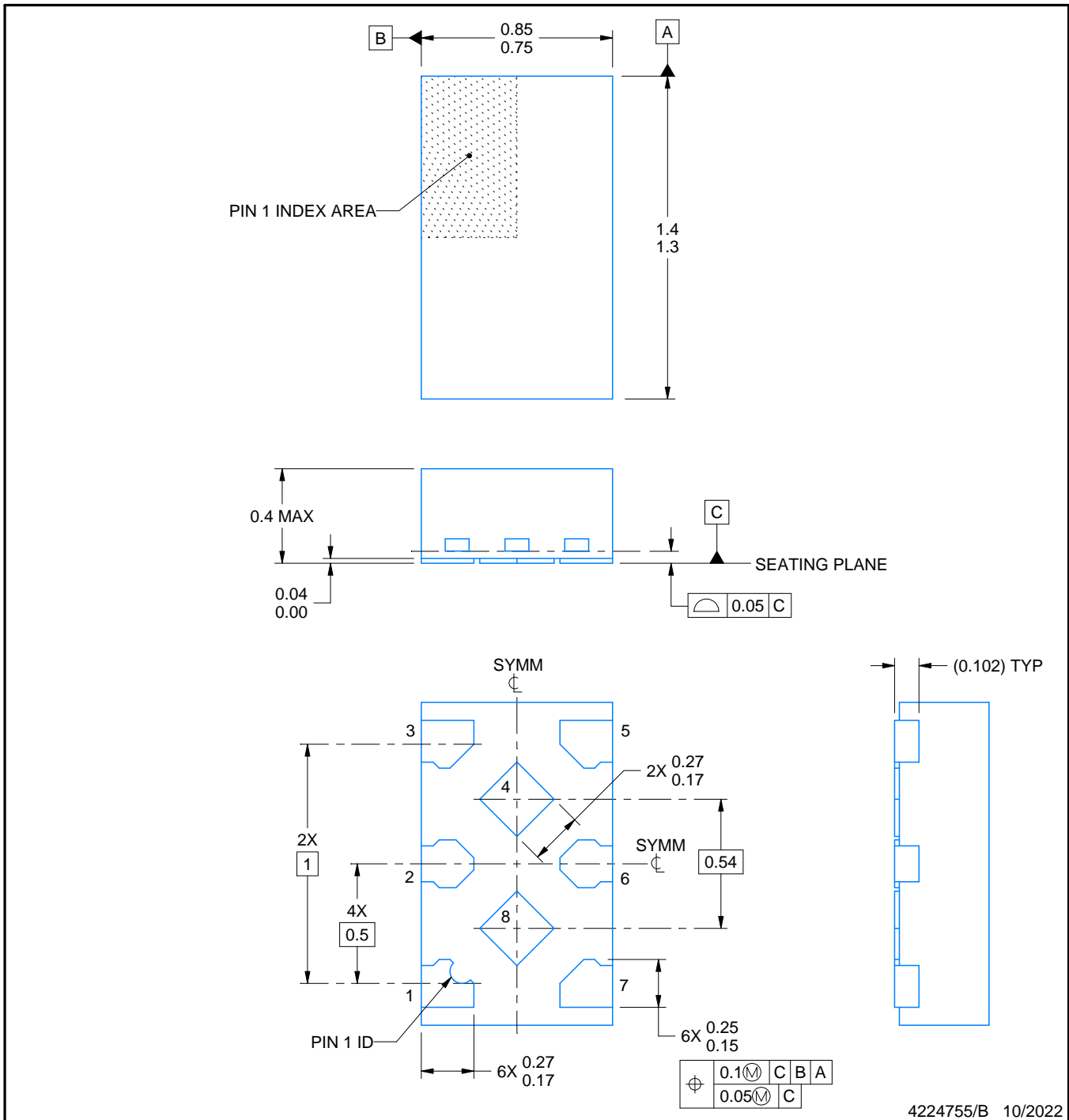

#### NOTES:

1. All linear dimensions are in millimeters. Any dimensions in parenthesis are for reference only. Dimensioning and tolerancing per ASME Y14.5M.
2. This drawing is subject to change without notice.
3. The package thermal pad(s) must be soldered to the printed circuit board for thermal and mechanical performance.

# EXAMPLE BOARD LAYOUT

DTM0008A

X2SON - 0.4 mm max height

PLASTIC SMALL OUTLINE - NO LEAD

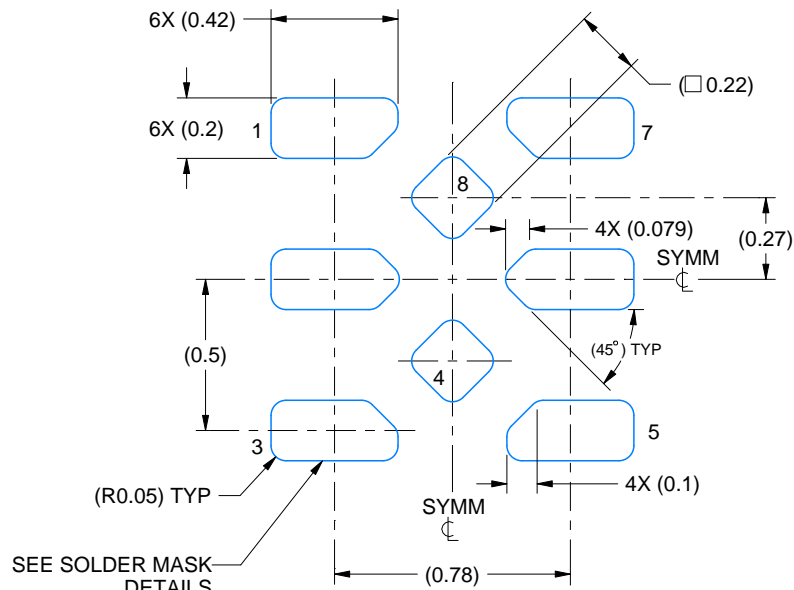

LAND PATTERN EXAMPLE  
EXPOSED METAL SHOWN  
SCALE:40X

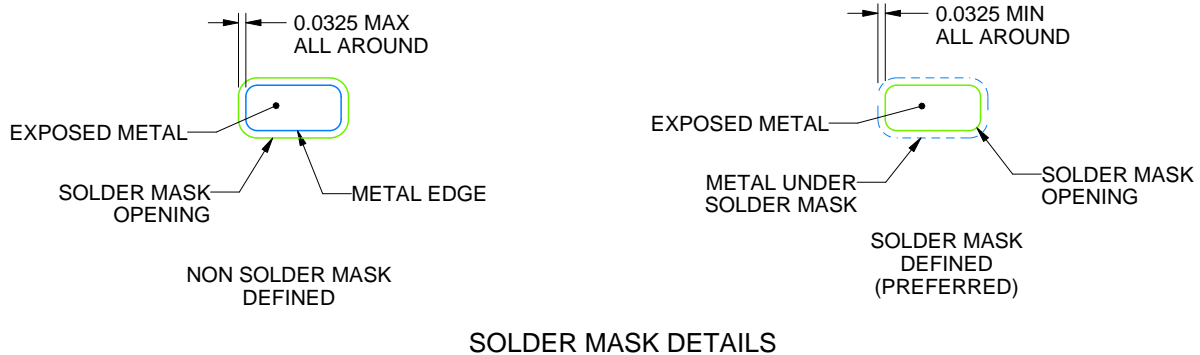

SOLDER MASK DETAILS

4224755/B 10/2022

NOTES: (continued)

- This package is designed to be soldered to a thermal pad on the board. For more information, see Texas Instruments literature number SLUA271 ([www.ti.com/lit/slua271](http://www.ti.com/lit/slua271)).

# EXAMPLE STENCIL DESIGN

DTM0008A

X2SON - 0.4 mm max height

PLASTIC SMALL OUTLINE - NO LEAD

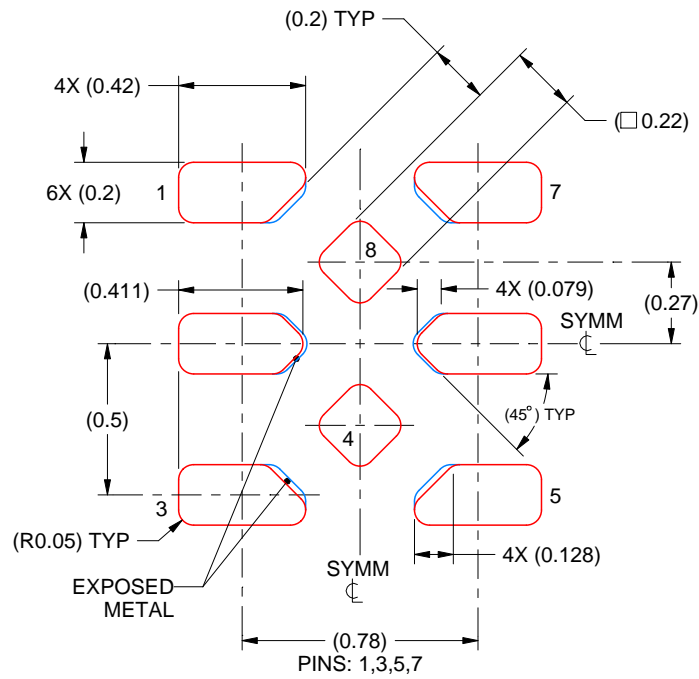

**SOLDER PASTE EXAMPLE**  
BASED ON 0.075 mm THICK STENCIL  
SCALE: 40X

4224755/B 10/2022

5. Laser cutting apertures with trapezoidal walls and rounded corners may offer better paste release. IPC-7525 may have alternate design recommendations.



## 重要声明和免责声明

TI“按原样”提供技术和可靠性数据（包括数据表）、设计资源（包括参考设计）、应用或其他设计建议、网络工具、安全信息和其他资源，不保证没有瑕疵且不做任何明示或暗示的担保，包括但不限于对适销性、某特定用途方面的适用性或不侵犯任何第三方知识产权的暗示担保。

这些资源可供使用 TI 产品进行设计的熟练开发人员使用。您将自行承担以下全部责任：(1) 针对您的应用选择合适的 TI 产品，(2) 设计、验证并测试您的应用，(3) 确保您的应用满足相应标准以及任何其他功能安全、信息安全、监管或其他要求。

这些资源如有变更，恕不另行通知。TI 授权您仅可将这些资源用于研发本资源所述的 TI 产品的应用。严禁对这些资源进行其他复制或展示。您无权使用任何其他 TI 知识产权或任何第三方知识产权。您应全额赔偿因在这些资源的使用中对 TI 及其代表造成的任何索赔、损害、成本、损失和债务，TI 对此概不负责。

TI 提供的产品受 [TI 的销售条款](#) 或 [ti.com](#) 上其他适用条款/TI 产品随附的其他适用条款的约束。TI 提供这些资源并不会扩展或以其他方式更改 TI 针对 TI 产品发布的适用的担保或担保免责声明。

TI 反对并拒绝您可能提出的任何其他或不同的条款。

邮寄地址：Texas Instruments, Post Office Box 655303, Dallas, Texas 75265

Copyright © 2023，德州仪器 (TI) 公司

## X-ON Electronics

Largest Supplier of Electrical and Electronic Components

*Click to view similar products for [Translation - Voltage Levels](#) category:*

*Click to view products by [Texas Instruments](#) manufacturer:*

Other Similar products are found below :

[NLSX4373DMR2G](#) [NLSX5012MUTAG](#) [NLSX0102FCT1G](#) [PCA9306FMUTAG](#) [MC100EPT622MNG](#) [NLSX3014MUTAG](#)  
[NLSX5011MUTCG](#) [NLVSX4373MUTAG](#) [NB3U23CMNTAG](#) [NLSX3013BFCT1G](#) [NLV7WBD3125USG](#) [NLSX3012DMR2G](#)  
[NLA9306MU3TCG](#) [PI4ULS3V304AZMAEX](#) [PI4ULS3V504AZMAEX](#) [74AVCH1T45FW3-7](#) [NLSX5011AMUTAG](#) [74AXP1T34GWH](#)  
[ST2149BQTR](#) [MC100ELT21DR2G](#) [MC100LVELT22MNRG](#) [MC10ELT20DR2G](#) [MC10EPT20MNR4G](#) [MC14504BFELG](#)  
[NLSV4T3234FCT1G](#) [NLSX3378BFCT1G](#) [UM3208QA](#) [UM3208H](#) [UM3304](#) [UM3304QT](#) [UM3202H](#) [UM3308](#) [RS0104YTQE12](#)  
[RS0204YUTQH12](#) [AW39204QNR](#) [AW39114FOR](#) [RS0104YTQF14](#) [RS0204YTQF14](#) [UM3204QT](#) [UM3204QB](#) [UM3204QV](#)  
[AIPTS0104TA14.TR](#) [AIPTB0104TA14.TR](#) [UM3304QS](#) [SN74LXC2T45DCUR](#) [TCA39306DTMR](#) [NTS0102TL-Q100H](#) [AW39112DNR](#)  
[XP7660](#) [RS4T774XTSS16](#)